

SUPERO®

SUPERSERVER 6023P-i

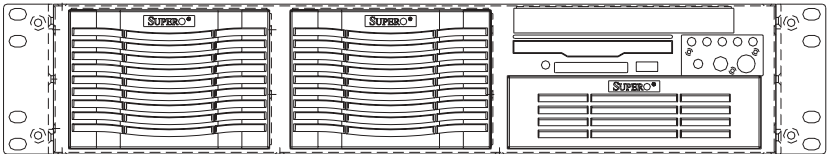

USER'S MANUAL

1.0b

The information in this User's Manual has been carefully reviewed and is believed to be accurate. The vendor assumes no responsibility for any inaccuracies that may be contained in this document, makes no commitment to update or to keep current the information in this manual, or to notify any person or organization of the updates. **Please Note: For the most up-to-date version of this manual, please see our web site at www.supermicro.com.**

SUPERMICRO COMPUTER reserves the right to make changes to the product described in this manual at any time and without notice. This product, including software, if any, and documentation may not, in whole or in part, be copied, photocopied, reproduced, translated or reduced to any medium or machine without prior written consent.

IN NO EVENT WILL SUPERMICRO COMPUTER BE LIABLE FOR DIRECT, INDIRECT, SPECIAL, INCIDENTAL, SPECULATIVE OR CONSEQUENTIAL DAMAGES ARISING FROM THE USE OR INABILITY TO USE THIS PRODUCT OR DOCUMENTATION, EVEN IF ADVISED OF THE POSSIBILITY OF SUCH DAMAGES. IN PARTICULAR, THE VENDOR SHALL NOT HAVE LIABILITY FOR ANY HARDWARE, SOFTWARE, OR DATA STORED OR USED WITH THE PRODUCT, INCLUDING THE COSTS OF REPAIRING, REPLACING, INTEGRATING, INSTALLING OR RECOVERING SUCH HARDWARE, SOFTWARE, OR DATA.

Any disputes arising between manufacturer and customer shall be governed by the laws of Santa Clara County in the State of California, USA. The State of California, County of Santa Clara shall be the exclusive venue for the resolution of any such disputes. Supermicro's total liability for all claims will not exceed the price paid for the hardware product.

Unless you request and receive written permission from SUPER MICRO COMPUTER, you may not copy any part of this document.

Information in this document is subject to change without notice. Other products and companies referred to herein are trademarks or registered trademarks of their respective companies or mark holders.

Copyright © 2003 by SUPER MICRO COMPUTER INC.
All rights reserved.

Printed in the United States of America

Preface

About This Manual

This manual is written for professional system integrators and PC technicians. It provides information for the installation and use of the SuperServer 6023P-i. Installation and maintenance should be performed by experienced technicians only.

The SuperServer 6023P-i is a high-end, dual Xeon processor rackmount server based on the SC822 2U rackmount server chassis and the X5DPi-G2 serverboard, which supports single or dual Xeon 512K L2 cache processors of up to 3.20 GHz and faster at a Front Side (System) Bus speed of 533/400 MHz and up to 16 GB of DDR-266/200 SDRAM memory.

Manual Organization

Chapter 1: Introduction

The first chapter provides a checklist of the main components included with the server system and describes the main features of the SUPER X5DPi-G2 serverboard and the SC822 chassis, which make up the SuperServer 6023P-i.

Chapter 2: Server Installation

This chapter describes the steps necessary to install the SuperServer 6023P-i into a rack and check out the server configuration prior to powering up the system. If your server was ordered without processor and memory components, this chapter will refer you to the appropriate sections of the manual for their installation.

Chapter 3: System Interface

Refer here for details on the system interface, which includes the functions and information provided by the control panel on the chassis as well as other LEDs located throughout the system.

Chapter 4: System Safety

You should thoroughly familiarize yourself with this chapter for a general overview of safety precautions that should be followed when installing and servicing the SuperServer 6023P-i.

Chapter 5: Advanced Serverboard Setup

Chapter 5 provides detailed information on the X5DPi-G2 serverboard, including the locations and functions of connectors, headers and jumpers. Refer to this chapter when adding or removing processors or main memory and when reconfiguring the serverboard.

Chapter 6: Advanced Chassis Setup

Refer to Chapter 6 for detailed information on the 2U SC822 rackmount server chassis. You should follow the procedures given in this chapter when installing, removing or reconfiguring peripheral drives and when replacing the system power supply unit and cooling fans.

Chapter 7: BIOS

The BIOS chapter includes an introduction to BIOS and provides detailed information on running the CMOS Setup Utility.

Appendix A: BIOS POST Messages

Appendix B: BIOS POST Codes

Appendix C: Supero Doctor III

Appendix D: System Specifications

Notes

Table of Contents

Preface

About This Manual	iii
Manual Organization	iii

Chapter 1: Introduction to the SuperServer 6023P-i

1-1 Overview	1-1
1-2 Serverboard Features	1-2
1-3 Server Chassis Features	1-5
1-4 Contacting Supermicro	1-5

Chapter 2: Server Installation

2-1 Overview	2-1
2-2 Unpacking the SuperServer 6023P-i	2-1
2-3 Preparing for Setup	2-1
Choosing a Setup Location	2-2
Rack Precautions	2-2
Server Precautions	2-2
2-4 Installing the SuperServer 6023P-i into a Rack	2-3
Identifying the Sections of the Rack Rails	2-3
Installing the Chassis Rails	2-4
Installing the Rack Rails	2-4
Installing the Server into the Rack	2-5
Installing the Server into a Telco Rack	2-6
2-5 Checking the Serverboard Setup	2-7
2-6 Checking the Drive Bay Setup	2-8

Chapter 3: System Interface

3-1 Overview	3-1
3-2 Control Panel Buttons	3-1
Reset	3-1
Power	3-1
3-3 Control Panel LEDs	3-2
Overheat	3-2
NIC2	3-2
NIC1	3-2
HDD	3-2
Power	3-3

3-4	Serverboard LEDs	3-3
-----	------------------------	-----

Chapter 4: System Safety

4-1	Electrical Safety Precautions	4-1
4-2	General Safety Precautions	4-2
4-3	ESD Precautions	4-3
4-4	Operating Precautions	4-4

Chapter 5: Advanced Serverboard Setup

5-1	Handling the X5DPi-G2 Serverboard	5-1
5-2	PGA Processor and Heatsink Installation	5-2
5-3	Connecting Cables	5-5
	Connecting Data Cables	5-5
	Connecting Power Cables	5-5
	Connecting the Control Panel	5-6
5-4	I/O Ports	5-7
5-5	Installing Memory	5-7
5-6	Adding PCI Cards	5-9
5-7	Serverboard Details	5-10
	X5DPi-G2 Layout	5-10
	X5DPi-G2 Quick Reference	5-11
5-8	Connector Definitions	5-12
	ATX Power Connection	5-12
	PWR_SEC Connection	5-12
	Power LED	5-12
	HDD LED	5-12
	NIC1 LED	5-13
	NIC2 LED	5-13
	Overheat LED	5-13
	Power Fail LED	5-13
	Reset Button	5-13
	Power Button	5-14
	Universal Serial Bus	5-14
	Extra USB Headers	5-14
	Serial Ports	5-15
	ATX PS/2 Keyboard & Mouse Ports	5-15
	Fan Headers	5-15
	LAN 1/2 (Ethernet Ports)	5-15
	Wake-On-LAN	5-16
	Wake-On-Ring	5-16

	Keylock	5-16
5-9	Jumper Settings	5-17
	Explanation of Jumpers	5-17
	CMOS Clear	5-17
	GLAN Enable/Disable	5-18
	Front Side Bus Speed	5-18
	VGA Enable/Disable	5-18
	Chassis/Overheat Fan Select	5-18
	Thermal Fan	5-19
	PCI-X Bus Speed Settings	5-19
	Watch Dog Enable/Disable	5-19
	Speaker Enable/Disable	5-20
5-10	Onboard Indicators	5-20
	LAN1/LAN2 LEDs	5-20
5-11	Parallel Port/Floppy/Hard Disk Drive Connections	5-21
	Parallel Port Connector	5-21
	Floppy Connector	5-22
	IDE Connectors	5-22
5-12	Installing Software Drivers	5-23

Chapter 6: Advanced Chassis Setup

6-1	Static-Sensitive Devices	6-1
6-2	Control Panel	6-2
6-3	System Fans	6-3
	System Fan Failure	6-3
	Replacing System Cooling Fans	6-3
6-4	Drive Bay Installation/Removal	6-4
	Accessing the Drive Bays	6-4
	Hard Drive Installation	6-5
	Installing a Component in the 5 1/4" Drive Bay.....	6-7
6-5	Power Supply	6-8
	Power Supply Failure	6-8
	Removing/Replacing the Power Supply	6-8

Chapter 7: BIOS

7-1	Introduction	7-1
7-2	Running Setup	7-2
7-3	Main BIOS Setup	7-2
	The Main BIOS Setup Menu	7-3

7-4 Advanced Setup..... 7-6
 7-5 Security 7-13
 7-6 Power 7-15
 7-7 Boot..... 7-17
 7-8 PIR 7-19
 7-9 Exit..... 7-21

Appendices:

Appendix A: BIOS POST Messages A-1
 Appendix B: BIOS Post Codes..... B-1
 Appendix C: Supero Doctor III C-1
 Appendix D: System Specifications D-1

Notes

Chapter 1

Introduction to the SuperServer 6023P-i

1-1 Overview

The SuperServer 6023P-i is a dual processor, 2U rackmount server that includes several advanced features. The 6023P-i is comprised of two main subsystems: the SC822 2U rackmount chassis and the X5DPi-G2 dual Xeon processor serverboard. Please refer to our web site for information on operating systems that have been certified for use with the 6023P-i. In addition to the serverboard and chassis, various hardware components may have been included with your SuperServer 6023P-i, as listed below:

- Two (2) CPU active heatsinks (FAN-042-CF)
- One (1) 3.5" floppy drive
- One (1) slim CD-ROM drive
- Rackmount hardware (with screws):
 - Two (2) rack rail assemblies
 - Six (6) brackets for mounting the rack rails to a rack/telco rack
- One (1) CD-ROM containing drivers and utilities:
 - Intel LANDesk Client Manager
 - ATI Rage XL 8MB PCI graphics controller driver
 - LAN driver
- Active riser card for X5DPi-G2 mainboard
- SuperServer 6023P-i User's Manual

1-2 Serverboard Features

At the heart of the SuperServer 6023P-i lies the X5DPi-G2, a dual Intel Xeon processor serverboard designed to provide maximum performance. Below are the main features of the X5DPi-G2.

Chipset

The Intel E7501 chipset is a high-performance chipset with a performance and feature-set designed for mid-range, dual processor servers. The E7501 chipset consists of four major components: the Memory Controller Hub (MCH), the I/O Controller Hub 3 (ICH3), the PCI-X 64-bit Hub 2.0 (P64H2) and the 82808AA Host Channel Adapter (VxB). See Figure 1-1 for a block diagram of the chipset.

The MCH has four hub interfaces, one to communicate with the ICH3 and three for high-speed I/O communications. The MCH employs a 144-bit wide memory bus for a DDR-266 memory interface, which provides a total bandwidth of 4.2 GB/s (3.2 GB/s for DDR-200). The ICH3 interface is a 266 MB/sec point-to-point connection using an 8-bit wide, 66 MHz base clock at a 4x data transfer rate. The P64H2 interface is a 1 GB/s point-to-point connection using a 16-bit wide, 66 MHz base clock at a 8x data transfer rate.

The ICH3 I/O Controller Hub provides various integrated functions, including a two-channel UDMA100 bus master IDE controller, USB host controllers, a System Management Bus controller and an AC'97 compliant interface.

The P64H2 PCI-X Hub provides a 16-bit connection to the MCH for high-performance IO capability and two 64-bit PCI-X interfaces.

Processors

The X5DPi-G2 supports single or dual Intel Xeon 512K L2 cache processors of up to 3.20 GHz at a 533/400 MHz FSB. Please refer to the support section of our web site for a complete listing of supported processors (<http://www.supermicro.com/support/>).

Memory

The X5DPi-G2 has eight 184-pin DIMM slots that can support up to 16 GB of registered ECC DDR-266/200 (PC2100/1600) SDRAM. Module sizes of 128 MB, 256 MB, 512 MB, 1 GB and 2 GB may be used to populate the DIMM slots. (The

X5DPi-G2 was designed to support 2 GB DIMM modules for each memory slot, but it has only been validated with 1GB memory modules.)

PCI Expansion Slots

The 6023P-i comes with a three-slot riser card that fits into the SXB (Super Extended Bus) slot on the X5DPi-G2. Three standard size PCI-X cards can be installed into the riser card and be supported by the SC822 chassis backplane.

ATI Graphics Controller

The X5DPi-G2 features an integrated ATI video controller based on the Rage XL graphics chip. Rage XL utilizes 8 MB of memory and fully supports sideband addressing. This onboard graphics package can provide a bandwidth of up to 512 MB/sec over a 32-bit graphics memory bus.

Onboard Controllers/Ports

The X5DPi-G2 includes one floppy drive controller and two onboard IDE controllers, which support up to four hard drives or ATAPI devices. Backpanel I/O ports include one COM port, two USB ports, PS/2 mouse and keyboard ports, a video (monitor) port and an Intel ANVIK controller for dual Gigabit Ethernet LAN ports.

Other Features

Other onboard features are included to promote system health. These include various voltage monitors, two CPU temperature sensors, four fan speed sensors, a chassis intrusion header, auto-switching voltage regulators, chassis and CPU overheat sensors, virus protection and BIOS rescue.

**Figure 1-1. Intel E7501 Chipset:
System Block Diagram**

Note: This is a general block diagram. Please see the previous pages for details on the X5DPi motherboard.

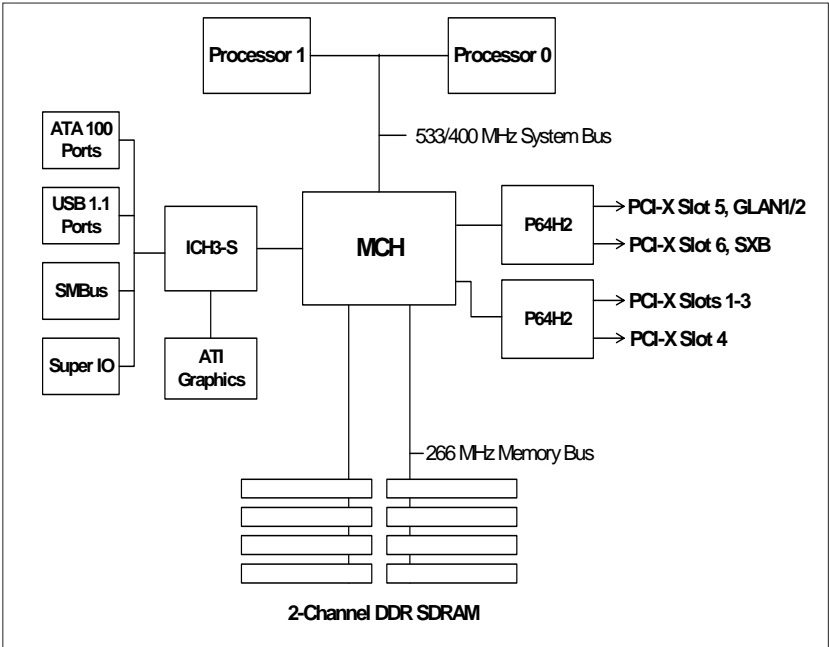

1-3 Server Chassis Features

The 6023P-i is a high-end, scaleable 2U rackmount server platform designed with state-of-the-art features. The following is a general outline of the main features of the SC822 chassis.

System Power

When configured as the 6023P-i, the SC822 chassis includes a single 400W auto-switching power supply.

Control Panel

The SC822 control panel provides important system monitoring and control information. LEDs indicate power on, power fail, network activity, hard disk drive activity and system overheat conditions. Also present are a main power button and a system reset button.

I/O Backplane

The backplane of the SC822 supports the use of up to three standard (full-sized) expansion cards and provides one COM port, one parallel port, one VGA port, two USB ports, PS/2 mouse and keyboard ports and two Gb Ethernet (LAN) ports. (See Figure 1-1.)

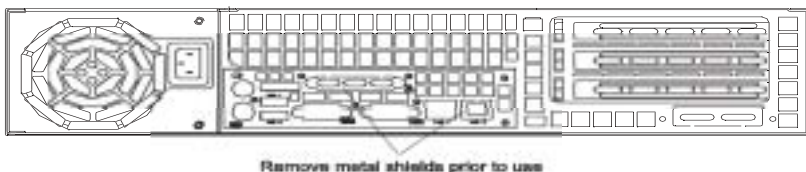

Figure 1-2. I/O Backplane

Cooling System

The SC822 chassis' revolutionary cooling design includes four 8-cm redundant system cooling (intake) fans. The fans plug into chassis fan connectors that are located behind the drive bays. They operate continuously at full rpm. If any fan fails and the ambient air temperature inside the chassis becomes too high, an overheat LED and alarm will be activated.

1-4 Contacting Supermicro

Headquarters

Address: SuperMicro Computer, Inc.
980 Rock Ave.
San Jose, CA 95131 U.S.A.

Tel: +1 (408) 503-8000

Fax: +1 (408) 503-8008

Email: marketing@supermicro.com (General Information)
support@supermicro.com (Technical Support)

Web Site: www.supermicro.com

Europe

Address: SuperMicro Computer B.V.
Het Sterrenbeeld 28, 5215 ML
's-Hertogenbosch, The Netherlands

Tel: +31 (0) 73-6400390

Fax: +31 (0) 73-6416525

Email: sales@supermicro.nl (General Information)
support@supermicro.nl (Technical Support)
rma@supermicro.nl (Customer Support)

Asia-Pacific

Address: SuperMicro, Taiwan
D5, 4F, No. 16 Chien-Ba Road
Chung-Ho 235, Taipei Hsien, Taiwan, R.O.C.

Tel: +886-(2) 8226-3990

Fax: +886-(2) 8226-3991

Web Site: www.supermicro.com.tw

Technical Support:

Email: support@supermicro.com.tw

Tel: 886-2-8228-1366, ext.132 or 139

Chapter 2

Server Installation

2-1 Overview

This chapter provides a quick setup checklist to get your SuperServer 6023P-i up and running. Following these steps in the order given should enable you to have the system operational within a minimum amount of time. This quick setup assumes that your SuperServer 6023P-i system has come to you with the processors and memory preinstalled. If your system is not already fully integrated with a serverboard, processors, system memory etc., please turn to the chapter or section noted in each step for details on installing specific components.

2-2 Unpacking the SuperServer 6023P-i

You should inspect the box the SuperServer 6023P-i was shipped in and note if it was damaged in any way. If the server itself shows damage you should file a damage claim with the carrier who delivered it.

Decide on a suitable location for the rack unit that will hold the SuperServer 6023P-i. It should be situated in a clean, dust-free area that is well ventilated. Avoid areas where heat, electrical noise and electromagnetic fields are generated. You will also need it placed near a grounded power outlet. Read the Rack and Server Precautions in the next section.

2-3 Preparing for Setup

The box the SuperServer 6023P-i was shipped in should include two sets of rail assemblies, two rail mounting brackets and the mounting screws you will need to install the system into the rack. Follow the steps in the order given to complete the installation process in a minimum amount of time. Please read this section in its entirety before you begin the installation procedure outlined in the sections that follow.

Choosing a Setup Location:

- Leave enough clearance in front of the rack to enable you to open the front door completely (~25 inches).
- Leave approximately 30 inches of clearance in the back of the rack to allow for sufficient airflow and ease in servicing.



Warnings and Precautions!



Rack Precautions:

- Ensure that the leveling jacks on the bottom of the rack are fully extended to the floor with the full weight of the rack resting on them.
- In single rack installation, stabilizers should be attached to the rack.
- In multiple rack installations, the racks should be coupled together.
- Always make sure the rack is stable before extending a component from the rack.
- You should extend only one component at a time - extending two or more simultaneously may cause the rack to become unstable.

Server Precautions:

- Review the electrical and general safety precautions in Chapter 4.
- Determine the placement of each component in the rack *before* you install the rails.
- Install the heaviest server components on the bottom of the rack first, and then work up.
- Use a regulating uninterruptible power supply (UPS) to protect the server from power surges, voltage spikes and to keep your system operating in case of a power failure.
- Allow the hard drives and power supply units to cool before touching them.
- Always keep the rack's front door and all panels and components on the servers closed when not servicing to maintain proper cooling.

2-4 Installing the SuperServer 6023P-i into a Rack

This section provides information on installing the SuperServer 6023P-i into a rack unit. If the 6023P-i has already been mounted into a rack, you can skip ahead to Sections 2-5 and 2-6. There are a variety of rack units on the market, which may mean the assembly procedure will differ slightly. The following is a guideline for installing the 6023P-i into a rack with the rack rails provided. You should also refer to the installation instructions that came with the rack unit you are using.

Identifying the Sections of the Rack Rails:

You should have received two rack rail assemblies with the SuperServer 6023P-i. Each of these assemblies consist of three sections: an inner fixed chassis rail that secures to the 6023P-i (A) and an outer fixed rack rail that secures directly to the rack itself (B). A sliding rail guide sandwiched between the two should remain attached to the fixed rack rail. (See Figure 2-1.) The A and B rails must be detached from each other to install.

To remove the fixed chassis rail (A), pull it out as far as possible - you should hear a "click" sound as a locking tab emerges from inside the rail assembly and locks the inner rail. Then depress the locking tab to pull the inner rail completely out. Do this for both the left and right side rack rail assemblies.

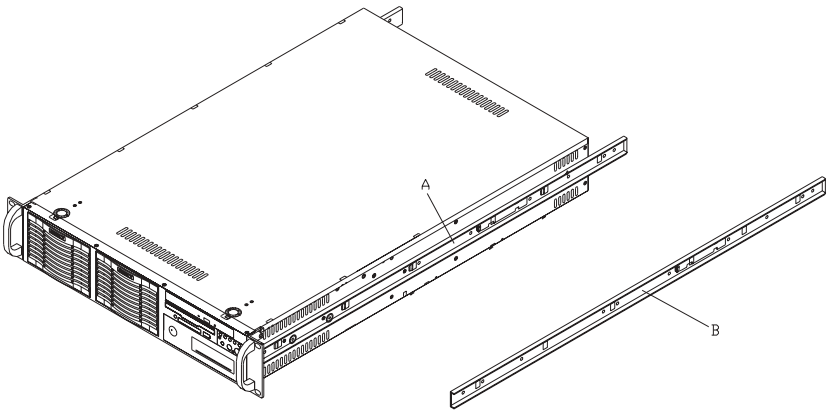

Figure 2-1. Identifying the Sections of the Rack Rails

Installing the Chassis Rails:

Position the fixed chassis rail sections you just removed along the side of the 6023P-i making sure the screw holes line up. Note that these two rails are left/right specific. Screw the rail securely to the side of the chassis (see Figure 2-2). Repeat this procedure for the other rail on the other side of the chassis. You will also need to attach the rail brackets when installing into a telco rack.

Locking Tabs: As you have seen, both chassis rails have a locking tab, which serves two functions. The first is to lock the server into place when installed and pushed fully into the rack, which is its normal position. Secondly, these tabs also lock the server in place when fully extended from the rack. This prevents the server from coming completely out of the rack when you pull it out for servicing.

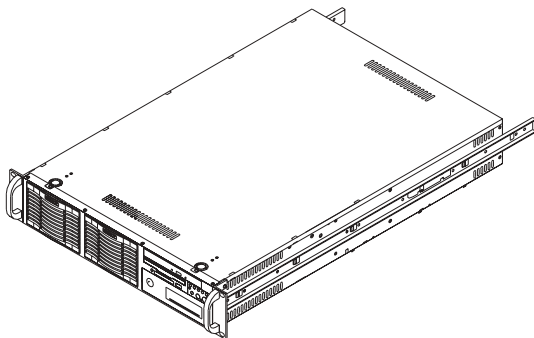

Figure 2-2. Installing Chassis Rails

Installing the Rack Rails:

Determine where you want to place the SuperServer 6023P-i in the rack. (See [Rack and Server Precautions in Section 2-3.](#)) Position the fixed rack rail/sliding rail guide assemblies at the desired location in the rack, keeping the sliding rail guide facing the inside of the rack. Screw the assembly securely to the rack using the brackets provided. Attach the other assem-

bly to the other side of the rack, making sure both are at the exact same height and with the rail guides facing inward.

Installing the Server into the Rack:

You should now have rails attached to both the chassis and the rack unit. The next step is to install the server into the rack. Do this by lining up the rear of the chassis rails with the front of the rack rails. Slide the chassis rails into the rack rails, keeping the pressure even on both sides (you may have to depress the locking tabs when inserting). See Figure 2-3.

When the server has been pushed completely into the rack, you should hear the locking tabs "click". Finish by inserting and tightening the thumbscrews that hold the front of the server to the rack.

Figure 2-3. Installing the Server into a Rack

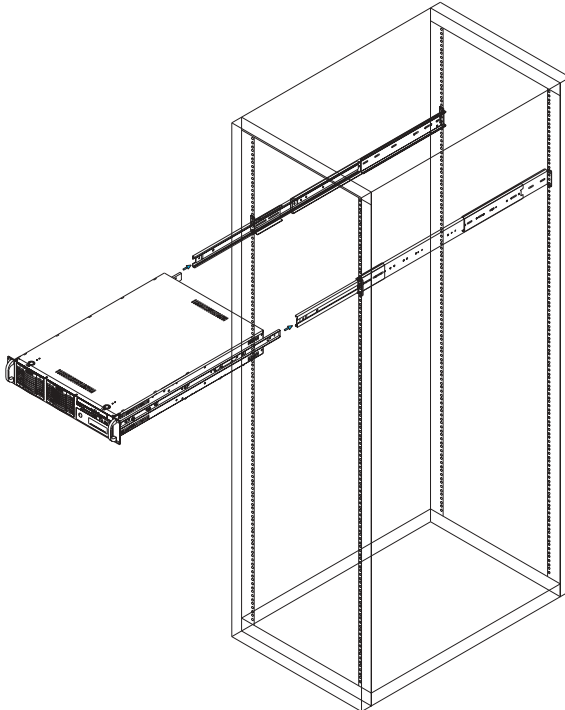

2-5 Checking the Serverboard Setup

After you install the 6023P-i in the rack, you will need to open the unit to make sure the motherboard is properly installed and all the connections have been made.

1. Accessing the inside of the 6023P-i (see Figure 2-5):

First, release the retention screws that secure the unit to the rack. Grasp the two handles on either side and pull the unit straight out until it locks (you will hear a "click"). Next, depress the two buttons on the top of the chassis to release the top cover. There is a large rectangular recess in the middle front of the top cover to help you push the cover away from you until it stops. You can then lift the top cover from the chassis to gain full access to the inside of the server.

2. Check the CPUs (processors):

You should have one or two processors already installed into the serverboard. Each processor needs its own heatsink. See Chapter 5 for instructions on processor and heatsink installation.

3. Check the system memory:

Your 6023P-i server system may have come with system memory already installed. Make sure all DIMMs are fully seated in their slots. For details on adding system memory, refer to Chapter 5.

4. Installing add-on cards:

If desired, you can install add-on cards to the system. See Chapter 5 for details on installing PCI add-on cards.

5. Check all cable connections and airflow:

Make sure all power and data cables are properly connected and not blocking the chassis airflow. See Chapter 5 for details on cable connections. Also, check the air seals for damage. The air seals are located under the blower fan and beneath the frame cross section that separates the drive bay area from the serverboard area of the chassis.

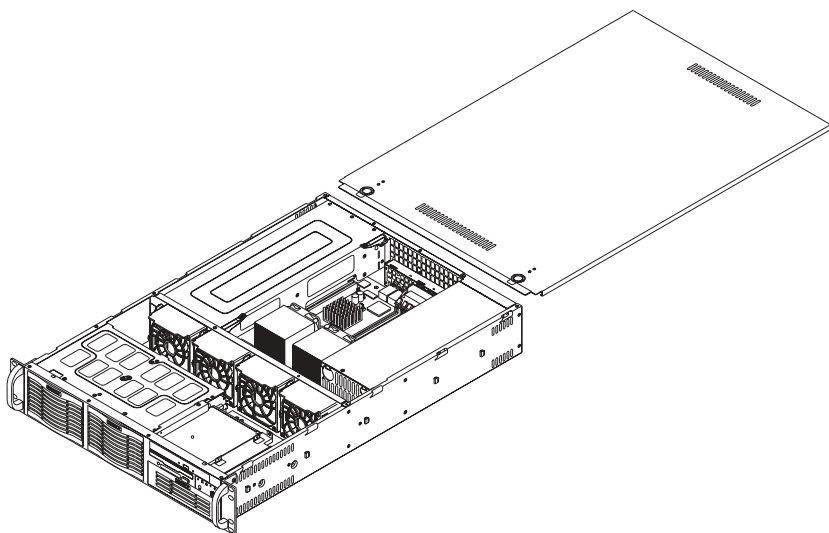

Figure 2-5. Accessing the Inside of the Server

2-6 Checking the Drive Bay Setup

Next, you should check to make sure the peripheral drives have been properly installed and all connections have been made.

1. Accessing the drive bays:

All drives are accessible from the front of the server. For servicing the CD-ROM and floppy drives, you will need to remove the top chassis cover. Hard disk drives can be installed and removed from the front of the chassis without removing the top chassis cover.

2. CD-ROM and floppy disk drives:

A slim CD-ROM and a floppy drive should be preinstalled in your server. Refer to Chapter 6 if you need to reinstall a CD-ROM and/or floppy disk drive to the system.

3. Check the airflow:

Airflow is provided by four heavy-duty 8-cm hot-swappable blower fans. The system component layout was carefully designed to direct sufficient cooling airflow to the components that generate the most heat. Note that all power and data cables have been routed in such a way that they do not block the airflow generated by the fans.

4. Supplying power to the system:

The last thing you must do is to provide input power to the system. Plug the power cord from the power supply unit into a high-quality power strip that offers protection from electrical noise and power surges. It is recommended that you use an uninterruptible power supply (UPS).

Notes

Chapter 3

System Interface

3-1 Overview

There are several LEDs on the control panel as well as others on the motherboard to keep you constantly informed of the overall status of the system as well as the activity and health of specific components. There are also two buttons on the chassis control panel.

3-2 Control Panel Buttons

There are two push-button buttons located on the front of the chassis. These are (in order from left to right) a reset button and a power on/off button.



- **RESET:** Use the reset button to reboot the system.

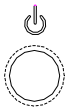

- **POWER:** This is the main power button, which is used to apply or turn off the main system power. Turning off system power with this button removes the main power but keeps standby power supplied to the system.

3-3 Control Panel LEDs

The control panel located on the front of the SC822 chassis has five LEDs. These LEDs provide you with critical information related to different parts of the system. This section explains what each LED indicates when illuminated and any corrective action you may need to take.



- **Overheat:** Indicates an overheat condition in the chassis. This may be caused by cables obstructing the airflow in the system or the ambient room temperature being too warm. You should also check to make sure that the chassis cover is installed and that all fans are present and operating normally. Verify that the heatsinks are installed properly (see Section 5-5 and Figure 5-4). Finally, check the air seals for damage. The air seals are located under the blower fan and beneath the frame cross section that separates the drive bay area from the serverboard area of the chassis.



NIC2

- **NIC2:** Indicates network activity on LAN2 when flashing.



NIC1

- **NIC1:** Indicates network activity on LAN1 when flashing.



- **HDD:** Indicates IDE channel activity. On the SuperServer 6023P-i, this LED indicates CD-ROM drive activity when flashing.



- **Power:** Indicates power is being supplied to the system's power supply units. This LED should normally be illuminated when the system is operating.

3-4 Serverboard LEDs

There is one primary LED on the serverboard. A power LED is located near the secondary power connector (J15). When illuminated, it indicates that system power is present on the serverboard.

Notes

Chapter 4

System Safety

4-1 Electrical Safety Precautions



Basic electrical safety precautions should be followed to protect yourself from harm and the SuperServer 6023P-i from damage:

- Be aware of the locations of the power on/off switch on the chassis as well as the room's emergency power-off switch, disconnection switch or electrical outlet. If an electrical accident occurs, you can then quickly remove power from the system.
- Do not work alone when working with high voltage components.
- Power should always be disconnected from the system when removing or installing main system components, such as the serverboard, memory modules and the CD-ROM and floppy drives. When disconnecting power, you should first power down the system with the operating system and then unplug the power cords of all the power supply units in the system.
- When working around exposed electrical circuits, another person who is familiar with the power-off controls should be nearby to switch off the power if necessary.
- Use only one hand when working with powered-on electrical equipment. This is to avoid making a complete circuit, which will cause electrical shock. Use extreme caution when using metal tools, which can easily damage any electrical components or circuit boards they come into contact with.
- Do not use mats designed to decrease electrostatic discharge as protection from electrical shock. Instead, use rubber mats that have been specifically designed as electrical insulators.

- The power supply power cord must include a grounding plug and must be plugged into grounded electrical outlets.
- Serverboard Battery: **CAUTION** - There is a danger of explosion if the onboard battery is installed upside down, which will reverse its polarities. On the X5DPi-G2, the positive side should be facing up. This battery must be replaced only with the same or an equivalent type recommended by the manufacturer. Dispose of used batteries according to the manufacturer's instructions.
- CD-ROM Laser: **CAUTION** - This may have come equipped with a CD-ROM drive. To prevent direct exposure to the laser beam and hazardous radiation exposure, do not open the enclosure or use the unit in any unconventional way.

4-2 General Safety Precautions



Follow these rules to ensure general safety:

- Keep the area around the SuperServer 6023P-i clean and free of clutter.
- The SuperServer 6023P-i weighs approximately 43 lbs (19.5 kg) when fully loaded. When lifting the system, two people at either end should lift slowly with their feet spread out to distribute the weight. Always keep your back straight and lift with your legs.
- Place the chassis top cover and any system components that have been removed away from the system or on a table so that they won't accidentally be stepped on.
- While working on the system, do not wear loose clothing such as neckties and unbuttoned shirt sleeves, which can come into contact with electrical circuits or be pulled into a cooling fan.
- Remove any jewelry or metal objects from your body, which are excellent metal conductors that can create short circuits and harm you if they come into contact with printed circuit boards or areas where power is present.

- After accessing the inside of the system, close the system back up and secure it to the rack unit with the retention screws after ensuring that all connections have been made.

4-3 ESD Precautions



Electrostatic discharge (ESD) is generated by two objects with different electrical charges coming into contact with each other. An electrical discharge is created to neutralize this difference, which can damage electronic components and printed circuit boards. The following measures are generally sufficient to neutralize this difference before contact is made to protect your equipment from ESD:

- Use a grounded wrist strap designed to prevent static discharge.
- Keep all components and printed circuit boards (PCBs) in their antistatic bags until ready for use.
- Touch a grounded metal object before removing the board from the antistatic bag.
- Do not let components or PCBs come into contact with your clothing, which may retain a charge even if you are wearing a wrist strap.
- Handle a board by its edges only; do not touch its components, peripheral chips, memory modules or contacts.
- When handling chips or modules, avoid touching their pins.
- Put the serverboard and peripherals back into their antistatic bags when not in use.
- For grounding purposes, make sure your computer chassis provides excellent conductivity between the power supply, the case, the mounting fasteners and the serverboard.

4-4 Operating Precautions



Care must be taken to assure that the chassis cover is in place when the 6023P-i is operating to assure proper cooling. Out of warranty damage to the 6023P-i system can occur if this practice is not strictly followed.

Chapter 5

Advanced Serverboard Setup

This chapter covers the steps required to install processors and heatsinks to the X5DPi-G2 serverboard, connect the data and power cables and install add-on cards. All serverboard jumpers and connections are described and a layout and quick reference chart are included in this chapter. Remember to close the chassis completely when you have finished working on the serverboard to protect and cool the system sufficiently.

5-1 Handling the X5DPi-G2 Serverboard

Static electrical discharge can damage electronic components. To prevent damage to printed circuit boards, it is important to handle them very carefully (see Chapter 4). Also note that the size and weight of the serverboard can cause it to bend if handled improperly, which may result in damage. To prevent the serverboard from bending, keep one hand under the center of the board to support it when handling. The following measures are generally sufficient to protect your equipment from static discharge.

Precautions

- Use a grounded wrist strap designed to prevent static discharge.
- Touch a grounded metal object before removing any board from its anti-static bag.
- Handle a board by its edges only; do not touch its components, peripheral chips, memory modules or gold contacts.
- When handling chips or modules, avoid touching their pins.
- Put the motherboard, add-on cards and peripherals back into their anti-static bags when not in use.

Unpacking

The serverboard is shipped in antistatic packaging to avoid static damage. When unpacking the board, make sure the person handling it is static protected.

5-2 PGA Processor and Heatsink Installation



When handling the processor package, avoid placing direct pressure on the label area of the fan. Also, do not place the serverboard on a conductive surface, which can damage the BIOS battery and prevent the system from booting up.

IMPORTANT: Always connect the power cord last and always remove it before adding, removing or changing any hardware components. Make sure that you install the processor into the CPU socket **before** you install the heatsink. The X5DPi-G2 can support either one or two Xeon processors of up to 3.20 GHz. If installing one processor only, install it into CPU socket #1.

1. Lift the lever on the CPU socket. Lift the lever completely or you will damage the CPU socket when power is applied. (Install a processor into CPU #1 socket first.)

Socket lever



2. Install the CPU in the socket. Make sure that pin 1 of the CPU is seated on pin 1 of the socket (both corners are marked with a triangle). When using only one CPU, install it into CPU socket #1 (CPU socket #2 is automatically disabled if only one CPU is used).

Pin 1

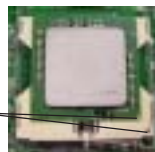

3. Press the lever down until you hear it *click* into the locked position. See Figure 5-1 for pictures of the 604-pin CPU socket before and after the processor is installed.

Socket lever in locked position

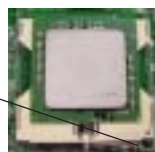

4. Apply the proper amount of thermal compound to the CPU die and place the heatsink on top of the CPU. Make sure the heatsink sits completely flat on the CPU. If not completely flat, the space between the two will degrade the heat dissipation function of the heatsink, which may cause the processor to overheat.

5. Secure the heatsink by locking each retention clip into its proper position. When correctly installed, the clips should *click* into place and the three black tabs on the CPU retention pieces should protrude fully through the corresponding holes on the each clip. See Figures 5-2a and 5-2b for diagrams of the retention clips and the heatsink installation procedure.

IMPORTANT: Please note that special, new silver heat sink retention clips must be used with all Xeon 533 MHz FSB (front side bus) 604-pin processors. These new retention clips have “604P” clearly marked on them. Using the old clips will not keep the proper amount of pressure applied and may cause the processor to overheat. In addition, you should not use these new retention clips with Xeon 400 MHz FSB processors (even in 604-pin CPU sockets) as they will be too tight and may damage the CPU socket.

6. If installing two processors, repeat these steps to install the second processor in the CPU #2 slot.

Figure 5-1. 604-pin PGA Socket: Empty and with Processor Installed



Warning! Make sure you lift the lever completely when installing the CPU. If the lever is only partly raised, damage to the socket or CPU may result.

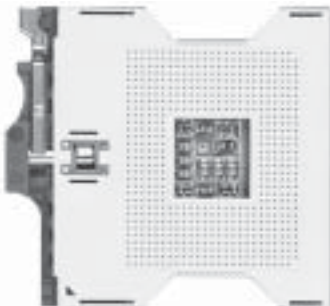

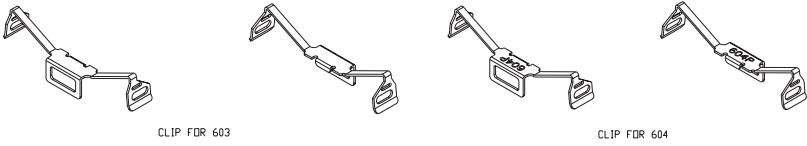

Figure 5-2a. Retention Clips (left: 603-pin, right: 604-pin)

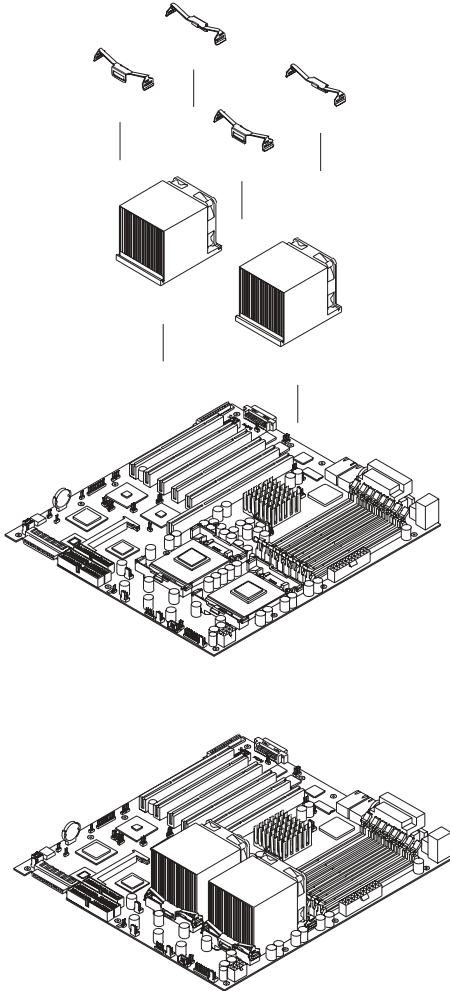

Figure 5-2b. Heatsink Installation (board shown is not X5DPi-G2)

5-3 Connecting Cables

Now that the processors are installed, the next step is to connect the cables to the board. These include the data (ribbon) cables for the peripherals and control panel and the power cables.

Connecting Data Cables

The ribbon cables used to transfer data from the peripheral devices have been carefully routed in preconfigured systems to prevent them from blocking the flow of cooling air that moves through the system from front to back. If you need to disconnect any of these cables, you should take care to keep them routed as they were originally after reconnecting them (make sure the red wires connect to the pin 1 locations). If you are configuring the system, keep the airflow in mind when routing the cables. The following data cables (with their serverboard connector locations noted) should be connected. See the serverboard layout figure in this chapter for connector locations.

- IDE Device Cables (IDE#1 and IDE#2)
- Floppy Drive Cable (JP7)
- Control Panel Cable (JF2, see next page)

Connecting Power Cables

The X5DPi-G2 has a 24-pin primary power supply connector designated "ATX Power" for connection to the ATX power supply. Connect the appropriate connector from the power supply to the "ATX Power" connector to supply power to the motherboard. The Secondary ATX Power Connector (at J15) must also be connected to your power supply. See the Connector Definitions section in this chapter for power connector pin definitions.

Connecting the Control Panel

JF2 contains header pins for various front control panel connectors. See Figure 5-3 for the pin locations of the various front control panel buttons and LED indicators. Please note that even and odd numbered pins are on opposite sides of each header.

All JF2 wires have been bundled into single ribbon cable to simplify their connection. Make sure the red wire plugs into pin 1 as marked on the board. The other end connects to the Control Panel printed circuit board, located just behind the system status LEDs in the chassis.

See the Connector Definitions section in this chapter for details and pin descriptions of JF2.

Figure 5-3. X5DPi-G2 Front Control Panel Header Pins

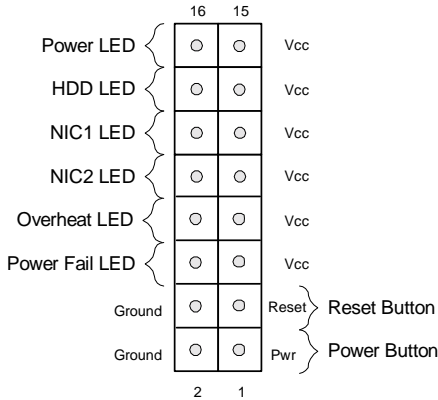

5-4 I/O Ports

The I/O ports are color coded in conformance with the PC 99 specification. See Figure 5-4 below for the colors and locations of the various I/O ports.

Figure 5-4. X5DPi-G2 Rear Panel I/O Ports

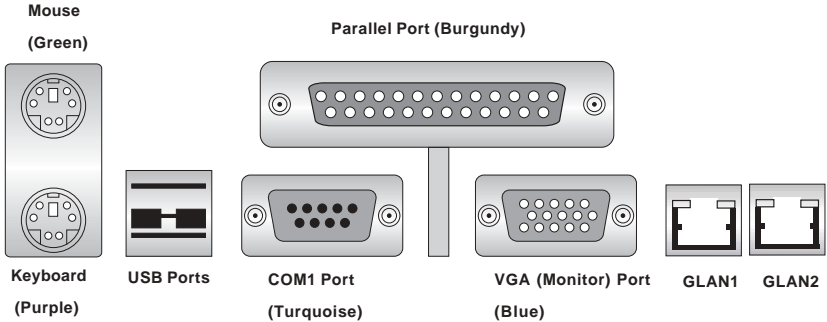

5-5 Installing Memory

Note: Check the Supermicro web site for recommended memory modules:
<http://www.supermicro.com/support/>

CAUTION

Exercise extreme care when installing or removing DIMM modules to prevent any possible damage. Also note that the memory is interleaved to improve performance (see step 1).

DIMM Installation (See Figure 5-5)

1. Insert the desired number of DIMMs into the memory slots, starting with Bank 1 (DIMM#1A, DIMM#1B). The memory scheme is interleaved so you must install two modules at a time, beginning with Bank 1, then Bank 2.
2. Insert each DIMM module into its slot. Pay attention to the notch along the bottom of the module to prevent inserting the DIMM module incorrectly.
3. Gently press down on the DIMM module until it snaps into place in the slot. Repeat for all modules (see step 1 above).

Memory Support

The X5DPi-G2 only supports ECC registered DDR-266/200 (PC2100/1600) memory. PC100/133 SDRAM is not supported. You should not mix DIMMs of different sizes and speeds.

See Figures 5-5a and 5-5b for installing and removing memory modules.

Figure 5-5a. Side View of DIMM Installation into Slot

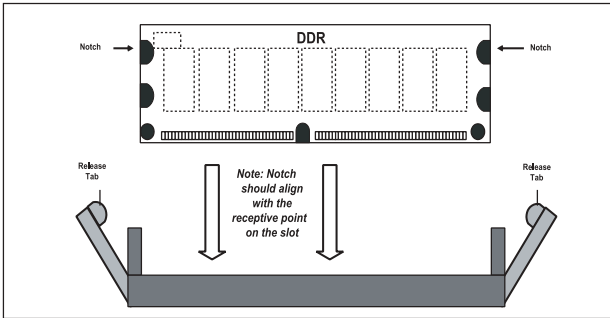

To Install: Insert module vertically and press down until it snaps into place. Pay attention to the bottom notch.

To Remove: Use your thumbs to gently push each release tab outward to free the DIMM from the slot.

Figure 5-5b. Top View of DIMM Slot

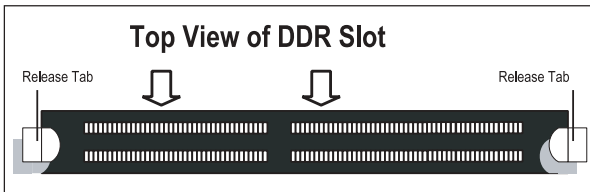

5-6 Adding PCI Cards

1. 64-bit PCI slot:

The X5DPi-G2 has a single 64-bit, 133 MHz PCI-X SXB slot. Three standard size PCI-X cards can be installed into the riser card and be supported by the SC822 chassis backplane.

2. 64-bit PCI card installation:

The system should be powered down when adding or removing PCI cards. Begin by removing the top cover of the chassis. You will see a metal enclosure that houses the riser card. Remove this housing by lifting the two plastic levers at either end and pulling the housing up and out of the chassis. The riser card is attached to the inside top of the housing. The riser card has three slots - you can change the frequency settings of slots PCI-X #2 and #3 with jumpers S1 and P1, respectively, which are located on the riser card. The default setting is PCI-X 100 MHz. A table for the S1/P1 jumper settings has been silk-screened on the riser card. The speed of PCI-X #1 is set with jumpers on the motherboard (see Section 5-9).

Release the latch that secures the PCI slot I/O shields to the housing by pulling it away from the housing. Remove the shield(s) and insert a PCI card(s) into the desired slot(s) on the riser card, pushing down with your thumbs evenly on both sides of the card. After all cards have been added, push the latch back into position. Replace the housing in the serverboard making sure the plastic levers properly catch on the chassis, then push them down to lock the housing in place. Finish by replacing the top chassis cover and powering up the system.

Note: The PCI slot I/O shields protect the serverboard and its components from EMI and aid in proper ventilation, so make sure there is always a shield covering each slot. Also, do not use the riser card included with the 6023P-i with any other serverboard and do not use any other riser card in the 6023P-i.

5-7 Serverboard Details

Figure 5-7. SUPER X5DPi-G2 Layout
(not drawn to scale)

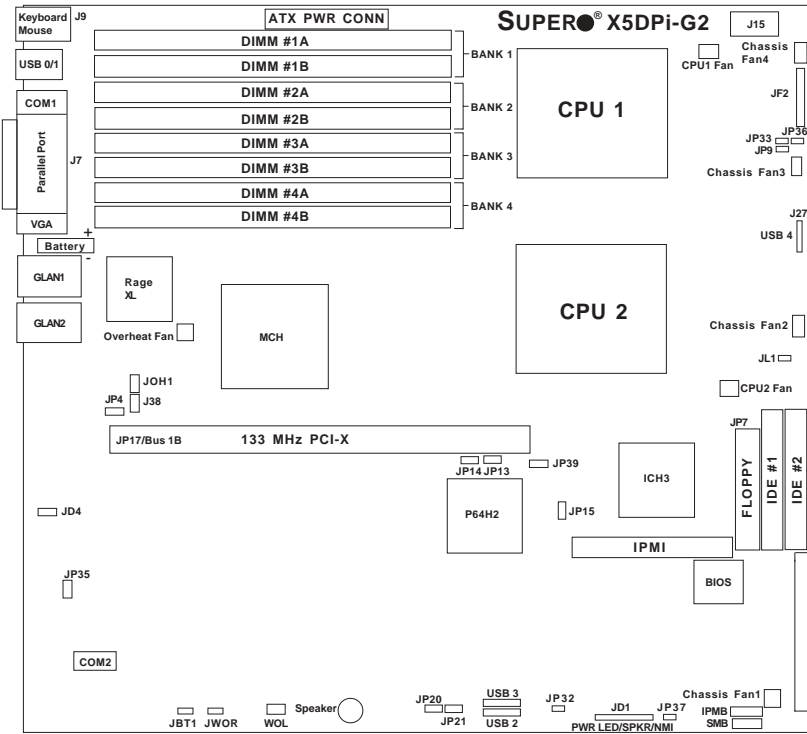

X5DPi-G2 Quick Reference

<u>Jumper</u>	<u>Description</u>	<u>Default Setting</u>
JBT1	CMOS Clear	Pins 1-2 (Normal)
JD1	Speaker Enable (page 2-11)	Close 6-7 (Enabled)
JD4	GLAN Enable/Disable	Pins 1-2 (Enabled)
JP4	VGA Enable/Disable	Pins 1-2 (Enabled)
JP9	Power Fail Alarm En/Disable	Open (Disabled)
JP13-JP15	PCI-X Bus Speed Setting	See Chp 5 Section 9
JP33	CPU Chassis/CPU Fan Select	Closed (CPU Fan)
JP37	Watch Dog Enable/Disable	Open (Disabled)
JP38	Thermal Fan	Closed (BIOS Cntrl)
JP39	Front Side (System) Bus Speed	Pins 1-2 (Auto)

<u>Connector</u>	<u>Description</u>
ATX PWR CONN	Primary ATX Power Connector
DIMM#1A-DIMM#4B	Memory (RAM) Slots
COM1/COM2	COM1/COM2 Serial Port Connector
CPU/CHS/OH FAN	CPU/Chassis/Overheat Fan Headers
GLAN1/2	Gb Ethernet Ports
IDE#1	IDE #1 Hard Disk Drive Connector
IDE#2	IDE #2 Hard Disk Drive Connector
J7	Parallel (Printer) Port
J9	PS/2 Keyboard/Mouse Ports
J13/J14	USB2/3 Headers
J15	Secondary ATX Power Connector
JD1	PWR LED/Speaker/NMI Header
JF2	Front Control Panel Connector
JL1	Chassis Intrusion Header
JOH1	Overheat LED
JP7	Floppy Disk Drive Connector
JP9	Third Power Supply Fail Header
JP32	ACPI/Sleep Button Header
JP35	Keylock Switch Connector
JP36	Alarm Reset Switch
JWOR	Wake-on-Ring Header
Speaker	Onboard Speaker Header
USB0/1, 2/3	Universal Serial Bus Ports, Headers
VGA	VGA Display (Monitor) Port
WOL	Wake-on-LAN Header

5-8 Connector Definitions

ATX Power Connection

The X5DPi-G2 power supply connector meets the SSI (Superset ATX) 24-pin specification, however it also supports a 20-pin power supply connector. Make sure that the orientation of the PS connector is correct. TSee the table on the right for pin definitions.

ATX Power Supply 24-pin Connector
Pin Definitions

Pin Number	Definition	Pin Number	Definition
13	+3.3V	1	+3.3V
14	-12V	2	+3.3V
15	COM	3	COM
16	PS_ON#	4	+5V
17	COM	5	COM
18	COM	6	+5V
19	COM	7	COM
20	Res(NC)	8	PWR_OK
21	+5V	9	5VSB
22	+5V	10	+12V
23	+5V	11	+12V
24	COM	12	+3.3V

PWR_SEC Connection

In addition to the Primary ATX power connector (above), the Secondary 12v 8-pin J15 connector must also be connected to your power supply. See the table on the right for pin definitions.

8-Pin +12v Power Supply
Connector (J15)

Pins	Definition
1 thru 4	Ground
5 thru 8	+12V

Power LED

The Power LED connection is located on pins 15 and 16 of JF2. Refer to the table on the right for pin definitions.

PWR_LED Pin Definitions
(JF2)

Pin Number	Definition
15	Vcc
16	Control

HDD LED

The HDD LED (for IDE disk drives) connection is located on pins 13 and 14 of JF2. Attach the IDE hard drive LED cable to these pins to display disk activity. Refer to the table on the right for pin definitions.

HDD LED Pin
Definitions
(JF2)

Pin Number	Definition
13	Vcc
14	HD Active

NIC1 LED

The NIC1 (Network Interface Controller) LED connection is located on pins 11 and 12 of JF2. Attach the NIC1 LED cable to display network activity. Refer to the table on the right for pin definitions.

**NIC1 LED Pin
Definitions
(JF2)**

Pin Number	Definition
11	Vcc
12	GND

NIC2 LED

The NIC2 (Network Interface Controller) LED connection is located on pins 9 and 10 of JF2. Attach the NIC2 LED cable to display network activity. Refer to the table on the right for pin definitions.

**NIC2 LED Pin
Definitions
(JF2)**

Pin Number	Definition
9	Vcc
10	GND

Overheat LED (OH)

Connect an LED to the OH connection on pins 7 and 8 of JF2 to provide advanced warning of chassis overheating. Refer to the table on the right for pin definitions.

**Overheat (OH) LED
Pin Definitions
(JF2)**

Pin Number	Definition
7	Vcc
8	GND

Power Fail LED

The Power Fail LED connection is located on pins 5 and 6 of JF2. Refer to the table on the right for pin definitions.

**Power Fail LED
Pin Definitions
(JF2)**

Pin Number	Definition
5	Vcc
6	GND

Reset Button

The connection for the system reset button is located on pins 3 and 4 of JF2. Refer to the table on the right for pin definitions.

**Reset Button
Pin Definitions
(JF2)**

Pin Number	Definition
3	Vcc
5	GND

Power Button

The Power Button connection is located on pins 1 and 2 of JF2. Momentarily contacting both pins will power on/off the system. This button can also be configured to function as a suspend button (see the Power Button Mode setting in BIOS). To turn off the power when set to suspend mode, depress the button for at least 4 seconds. Refer to the table on the right for pin definitions.

**Power Button
Connector
Pin Definitions
(JF2)**

Pin Number	Definition
1	PW_ON
2	Ground

Universal Serial Bus (USB0/1)

Two Universal Serial Bus ports are located beside the PS/2 keyboard/mouse ports. USB0 is the bottom and USB1 is the top connector. See the table on the right for pin definitions. There is an additional USB header (designated USB 4) located near the Chassis Fan 3 header. USB4 is not a Legacy-supported header. This means that any device attached to this USB header will not operate outside of the operating system.

Universal Serial Bus Pin Definitions

USB0		USB1	
Pin Number	Definition	Pin Number	Definition
1	+5V	1	+5V
2	P0-	2	P0-
3	P0+	3	P0+
4	Ground	4	Ground
5	N/A	5	Key

Extra Universal Serial Bus Headers (FPUSB0/1)

The Front Panel USB0/USB1 headers are located at JD2. These are separate from the ports on the I/O panel. You will need a USB cable (not included) to use either connection. Refer to the table on the right for pin definitions.

**Front Panel Universal Serial Bus Pin
Definitions**

FPUSB0		FPUSB1	
Pin Number	Definition	Pin Number	Definition
1	+5V	1	+5V
2	P0-	2	P0-
3	P0+	3	P0+
4	Ground	4	Ground
5	N/A	5	Key

Serial Ports

The COM1 serial port is located under the parallel port. See the table on the right for pin definitions. See the motherboard layout page for the location of the COM2 header.

**Serial Port Pin Definitions
(COM1, COM2)**

Pin Number	Definition	Pin Number	Definition
1	DCD	6	CTS
2	DSR	7	DTR
3	Serial In	8	RI
4	RTS	9	Ground
5	Serial Out	10	NC

ATX PS/2 Keyboard and PS/2 Mouse Ports

The ATX PS/2 keyboard and the PS/2 mouse are located on J29. See the table on the right for pin definitions. (The mouse port is above the keyboard port. See Figure 2-3.)

**PS/2 Keyboard and Mouse Port Pin Definitions
(J29)**

Pin Number	Definition
1	Data
2	NC
3	Ground
4	VCC
5	Clock
6	NC

Fan Headers

The motherboard has six fan headers. These are designated Designations include CPU Fan1, CPU Fan2, CPU1 Chassis Fan, CPU2 Chassis Fan, Chassis Fan1, Chassis Fan2 and Overheat Fan.. See the table on the right for pin definitions.

Fan Header Pin Definitions

Pin Number	Definition
1	Ground (black)
2	+12V (red)
3	Tachometer

Caution: These fan headers are DC power.

LAN1/2 (Ethernet Ports)

Two Ethernet ports (designated LAN1 and LAN2) are located beside the VGA port on the IO backplane. These ports accept RJ45 type cables.



Wake-On-LAN

The Wake-On-LAN header is designated as WOL. See the table on the right for pin definitions. You must enable the LAN Wake-Up setting in BIOS to use this feature. You must also have a LAN card with a Wake-on-LAN connector and cable.

Wake-On-LAN Pin Definitions (WOL)

Pin Number	Definition
1	+5V Standby
2	Ground
3	Wake-up

Wake-On-Ring

The Wake-On-Ring header is designated WOR. This function allows your computer to receive and "wake-up" by an incoming call to the modem when in suspend state. See the table on the right for pin definitions. You must have a WOR card and cable to use this feature.

Wake-on-Ring Pin Definitions (WOR)

Pin Number	Definition
1	Ground
2	Wake-up

Keylock

The keyboard lock connection is located on JP35. Utilizing this header allows you to inhibit any actions made on the keyboard, effectively "locking" it.

5-9 Jumper Settings

Explanation of Jumpers

To modify the operation of the serverboard, jumpers can be used to choose between optional settings. Jumpers create shorts between two pins to change the function of the connector. Pin 1 is identified with a square solder pad on the printed circuit board. See the serverboard layout page for jumper locations.

Note: On two pin jumpers, "Closed" means the jumper is on and "Open" means the jumper is off the pins.

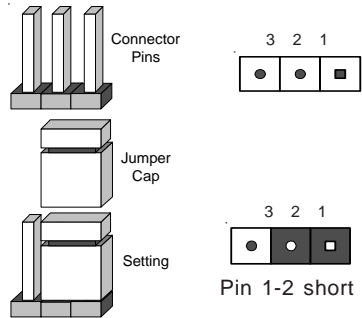

CMOS Clear

JBT1 is used to clear CMOS (which will also clear any passwords). Instead of pins, this jumper consists of contact pads to prevent accidentally clearing the contents of CMOS.

To clear CMOS, 1) First unplug the power cord(s) 2) With the power disconnected, short the CMOS pads with a metal object such as a small screwdriver 3) Remove the screwdriver (or shorting device) 4) Reconnect the power cord(s) and power on the system.

Note: Do not use the PW ON connector to clear CMOS.

GLAN Enable/Disable

Change the setting of jumper JD4 to enable or disable the onboard GLAN ports (GLAN1 and GLAN2) on the motherboard. See the table on the right for jumper settings. The default setting is enabled

**GLAN
Enable/Disable
Jumper Settings
(JD4)**

Jumper Position	Definition
Pins 1-2	Enabled
Pins 2-3	Disabled

Front Side Bus Speed

JP39 is used to set the front side (system) bus speed for the processors. It is best to keep this jumper set to Auto. This jumper is used together with the CPU Clock setting in BIOS. See the table on the right for jumper settings.

**Front Side Bus Speed
Jumper Settings (JP39)**

Jumper Position	Definition
Pins 1-2	Auto
Pins 2-3	400 MHz
Open	533 Mhz

VGA Enable/Disable

JP4 allows you to enable or disable the VGA port. The default position is on pins 1 and 2 to enable VGA. See the table on the right for jumper settings.

**VGA Enable/Disable
Jumper Settings
(JP4)**

Jumper Position	Definition
1-2	Enabled
2-3	Disabled

Chassis/Overheat Fan Select

JP33 allows you to select to use either the CPU fan or the Chassis fan. The default position is open to select the CPU fan. The CPU Chassis fan is intended for use with Supermicro chassis. See the table on the right for jumper settings.

**CPU Chassis/CPU Fan
Select Jumper Settings
(JP33)**

Jumper Position	Definition
Open	CPU
Closed	CPU Chassis

Thermal Fan

JP38 allows you to control the chassis fan as follows. With the jumper open, the fan operates continuously as a normal chassis fan. With the jumper closed, the BIOS assumes control and activates the fan only when a predefined temperature threshold has been exceeded. See the table on the right for jumper settings.

**Thermal Fan
Jumper Settings (JP38)**

Jumper Position	Definition
Open	Chassis Fan
Closed	BIOS Controlled

PCI-X Bus Speed Settings

Jumpers JP13 through JP15 are used to set the speed for the PCI-X bus for the SXB slot. Refer to the table on the right to set the speed of the single PCI-X slot with jumpers JP13, JP14 and JP15. The default setting is 100 MHz.

PCI-X Bus Speed Jumper Settings

JP14	JP15	JP13	Protocol	Max. Freq.
Off	Off	Off	PCI-X	133 MHz
Off	On	Off	PCI-X	100 MHz
Off	On	Pins 1-2	PCI-X	66 MHz
Off	On	Pins 2-3	PCI	66 MHz
On	On	Pins 2-3	PCI	33 MHz

Watch Dog Enable/Disable

The Watch Dog (located on JP37) allows you to enable or disable the Watch Dog feature. The default position is open to disable the Watch Dog timer. When enabled, Watch Dog can reboot your PC if an application is "hung up" or the system goes down. See the table on the right for jumper settings.

**Watch Dog Timer Enable/
Disable Jumper Settings
(JP37)**

Jumper Position	Definition
Open	Disabled
Closed	Enabled

Speaker Enable/Disable

On the JD1 header, add a jumper to pins 6-7 to enable the onboard speaker. If you wish to use an external speaker, remove it to disable the onboard speaker.

5-10 Onboard Indicators

GLAN1/GLAN2 LEDs

The Ethernet ports (located beside the VGA port) have two LEDs. See the table on the right for the functions associated with the LED on the right side. On each GLAN port, the yellow LED indicates activity while the other LED may be green, orange or off to indicate the speed of the connection.

**Gb LAN Right LED
Indicator (LAN1/2)**

LED Color	Definition
Off	No Connection
Green	100 MHz
Orange	1 GHz

5-11 Parallel Port/Floppy/Hard Disk Drive Connections

Note the following when connecting the floppy and hard disk drive cables:

- The floppy disk drive cable has seven twisted wires.
- A red mark on a wire typically designates the location of pin 1.
- A single floppy disk drive ribbon cable has 34 wires and two connectors to provide for two floppy disk drives. The connector with twisted wires always connects to drive A, and the connector that does not have twisted wires always connects to drive B.

Parallel Port Connector

The parallel (printer) port is located on J7. See the table on the right for pin definitions.

Parallel (Printer) Port Pin Definitions
(J7)

Pin Number	Function	Pin Number	Function
1	Strobe-	2	Auto Feed-
3	Data Bit 0	4	Error-
5	Data Bit 1	6	Init-
7	Data Bit 2	8	SLCT IN-
9	Data Bit 3	10	GND
11	Data Bit 4	12	GND
13	Data Bit 5	14	GND
15	Data Bit 6	16	GND
17	Data Bit 7	18	GND
19	ACK	20	GND
21	BUSY	22	GND
23	PE	24	GND
25	SLCT	26	NC

Floppy Connector

The floppy connector is located on JP7. See the table at right for pin definitions.

Floppy Connector Pin Definitions (JP7)

Pin Number	Function	Pin Number	Function
1	GND	2	FDHDIN
3	GND	4	Reserved
5	Key	6	FDEDIN
7	GND	8	Index-
9	GND	10	Motor Enable
11	GND	12	Drive Select B-
13	GND	14	Drive Select A-
15	GND	16	Motor Enable
17	GND	18	DIR-
19	GND	20	STEP-
21	GND	22	Write Data-
23	GND	24	Write Gate-
25	GND	26	Track 00-
27	GND	28	Write Protect-
29	GND	30	Read Data-
31	GND	32	Side 1 Select-
33	GND	34	Diskette

IDE Connectors

There are no jumpers to configure the onboard IDE#1 and #2 connectors. See the table at right for pin definitions.

**IDE Connector Pin Definitions
(IDE#1, IDE#2)**

Pin Number	Function	Pin Number	Function
1	Reset IDE	2	GND
3	Host Data 7	4	Host Data 8
5	Host Data 6	6	Host Data 9
7	Host Data 5	8	Host Data 10
9	Host Data 4	10	Host Data 11
11	Host Data 3	12	Host Data 12
13	Host Data 2	14	Host Data 13
15	Host Data 1	16	Host Data 14
17	Host Data 0	18	Host Data 15
19	GND	20	Key
21	DRQ3	22	GND
23	I/O Write-	24	GND
25	I/O Read-	26	GND
27	IOCHRDY	28	BALE
29	DACK3-	30	GND
31	IRQ14	32	IOCS16-
33	Addr 1	34	GND
35	Addr 0	36	Addr 2
37	Chip Select 0	38	Chip Select 1-
39	Activity	40	GND

5-12 Installing Software Drivers

After all the hardware has been installed you must install the software drivers. The necessary drivers are all included on the Supermicro CD that came packaged with your serverboard. After inserting this CD into your CD-ROM drive, a display similar to the one shown in Figure 5-8 should appear. (If this display does not appear, double click on the "My Computer" icon and then on the icon representing your CD-ROM drive. Finally, double click on the S "Setup" icon.)

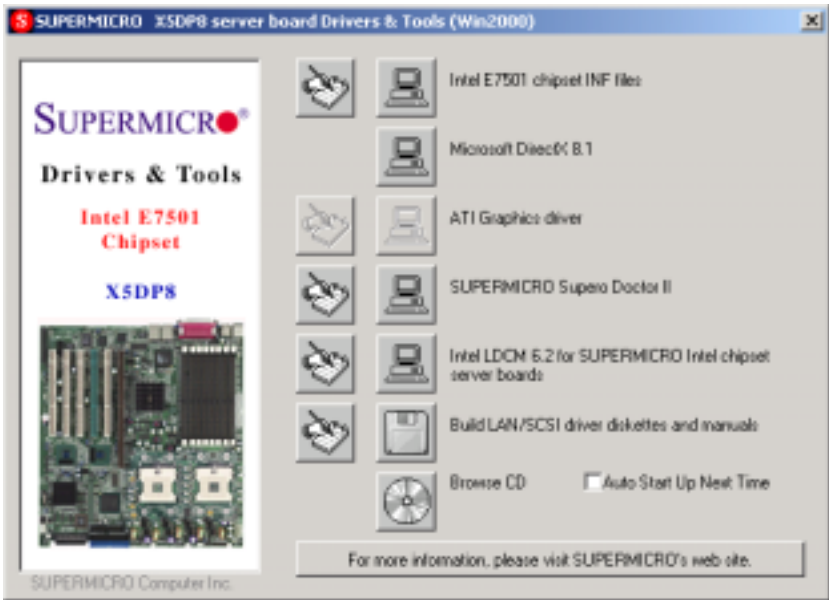

Figure 5-8 Driver/Tool Installation Display Screen

Click the icons showing a hand writing on paper to view the readme files for each item. The bottom icon with a CD on it allows you to view the entire contents of the CD.

Notes

Chapter 6

Advanced Chassis Setup

This chapter covers the steps required to install components and perform maintenance on the SC822 chassis. For component installation, follow the steps in the order given to eliminate the most common problems encountered. If some steps are unnecessary, skip ahead to the step that follows.

Tools Required

The only tool you will need to install components and perform maintenance is a Philips screwdriver.

6-1 Static-Sensitive Devices

Electricstatic discharge (ESD) can damage electronic components. To prevent damage to any printed circuit boards (PCBs), it is important to handle them very carefully. The following measures are generally sufficient to protect your equipment from ESD damage.

Precautions

- Use a grounded wrist strap designed to prevent static discharge.
- Touch a grounded metal object before removing any board from its anti-static bag.
- Handle a board by its edges only; do not touch its components, peripheral chips, memory modules or gold contacts.
- When handling chips or modules, avoid touching their pins.
- Put the serverboard, add-on cards and peripherals back into their anti-static bags when not in use.
- For grounding purposes, make sure your computer chassis provides excellent conductivity between the power supply, the case, the mounting fasteners and the serverboard.

Unpacking

The serverboard is shipped in antistatic packaging to avoid static damage. When unpacking the board, make sure the person handling it is static protected.

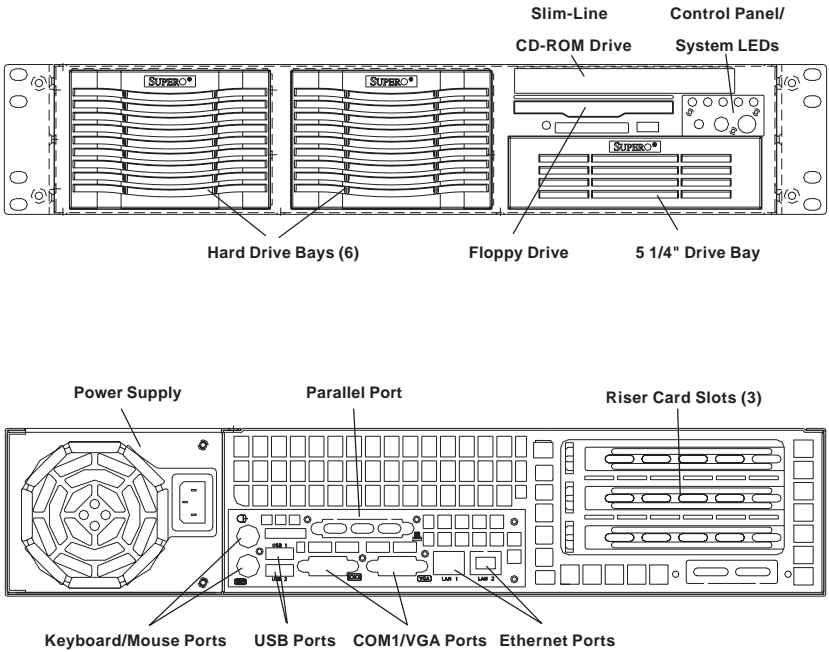

Figure 6-1. Chassis: Front and Rear Views

6-2 Control Panel

The control panel (located on the front of the chassis) must be connected to the JF2 connector on the serverboard to provide you with system status indications. A ribbon cable has bundled these wires together to simplify the connection. Connect the cable from JF2 on the serverboard to JP4 on the Control Panel PCB (printed circuit board). Make sure the red wire plugs into pin 1 on both JF2 and JP4. Pull all excess cabling out of the airflow path. The LEDs inform you of system status. See "Chapter 3: System Interface" for details on the LEDs and the control panel buttons. Details on JF2 can be found in the "Chapter 5: Advanced Serverboard Installation."

6-3 System Fans

Four heavy-duty 8-cm fans provide all the cooling needed for the Super-Server 6023P-i. It is very important that the chassis top cover is properly installed and making a good seal in order for the cooling air to circulate properly through the chassis and cool the components. See Figure 6-2.

System Fan Failure

The fans run at 3400 rpm. If a fan fails, the ambient air temperature in the chassis will rise and activate the overheat LED on the control panel. Replace any failed fan immediately. The hot plug fans will start to function upon connection to its fan header on the X5DPi-G2 serverboard.

Replacing System Cooling Fans

1. Removing a fan:

Remove the chassis cover. Press the tabs on the top of the fan housing and remove the fan and its housing. The system power need not be shut down since the fans are all hot-swappable on the X5DPi-G2 serverboard.

2. Installing a new fan:

Replace the failed fan with an identical 8-cm, 12 volt fan (available from Supermicro, p/n Fan-044). Position the new fan at its proper place in the chassis by fitting the fan with its housing onto the fan mounts in the chassis. A "click" can be heard if the fan (in its housing) is properly installed. If the system power is on, the hot-swappable fan feature will cause the fan to start immediately upon being connected to its header on the serverboard.

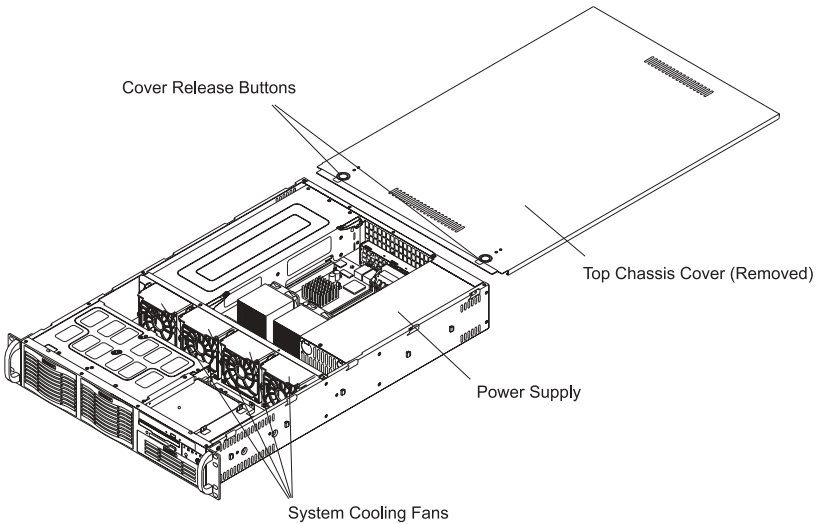

Figure 6-2. System Cooling Fans

6-4 Drive Bay Installation/Removal

Accessing the Drive Bays

3.5" Drive Bays: For installing/removing an IDE hard drive, CD-ROM or floppy disk drive, you will need to gain access to the inside of the 6023P-i by removing the top cover of the chassis. Proceed to the "Hard Drive Installation" section that follows for instructions.

5 1/4" Drive Bay: For installing/removing a component in the 5 1/4" drive bay, proceed to the Installing a Component in the "5 1/4" Drive Bay" section in this chapter for instructions.



Important: Regardless of how many hard drives are installed, all drive carriers and server face plates must remain in place for proper airflow.

Hard Drive Installation

1. Hard drive support:

Hard disk drives may be installed in the six internal 3.5" drive bays as well as in the 5.25" drive bay. Hard drives should be mounted in drive carriers for installation, to help promote proper airflow and shield against EMI. For this reason, even empty carriers without hard drives installed should remain in the chassis. You must power down the system before installing or removing any hard drive.

2. Mounting a hard drive in a drive carrier:

IDE hard drives are not hot-swappable, meaning system power must be turned off before installing and/or removing them. After power is removed from the system, remove the top cover of the chassis to access the drive carriers, which may then be unscrewed and taken out. When installing a hard disk drive, position it in the carrier with the printed circuit board side toward the carrier and with the drive's mounting holes aligned with those in the carrier. Secure the drive to the carrier with four screws, as shown in Figure 6-3. Connect the drive's ribbon and power cables to the motherboard, then replace the chassis cover before powering on.

3. Removing hard drives:

To remove a hard drive and its carrier, first power down the system and then remove the top cover of the chassis. Detach the ribbon and power cables from the drive. Unscrew the retention screw at the top center of the drive, then push the drive carrier out from the back until you can grasp and pull it out through the front of the chassis. Attach a new component to the carrier if desired (as in step 2), then reverse the drive carrier removal procedure described in this step to reinstall the carrier. Remember to screw in the retention screw. Replace the top cover when finished.

Figure 6-3. Mounting a Drive in a Carrier

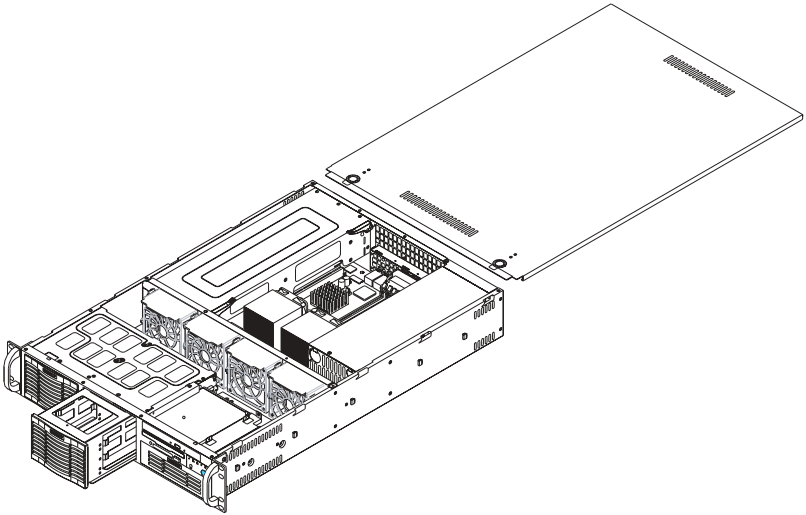

Installing a Component in the 5 1/4" Drive Bay

1. Mounting the component in the drive carrier

A component such as an IDE hard drive can be mounted in the 5 1/4" drive bay. The component should also be mounted in a drive carrier to simplify its installation and removal from the chassis. These carriers also help promote proper airflow. To add a component such as those noted above, install a drive into the carrier with the printed circuit board side toward the carrier so that the mounting holes align with those in the carrier. Secure the drive to the carrier with the four screws.

2. Installing/removing 5 1/4" drive bay component

A single 5 1/4" IDE drive bay is located in the front of the chassis, making it easily accessible for installation and removal. This component is not hot-swappable, meaning system power must be turned off before installing and/or removing. To remove the drive carrier, first power down the system and then remove the top cover of the chassis. Unscrew the retention screw at the top center of the drive, then push the drive carrier out from the back until you can grasp and pull it out through the front of the chassis. Attach the component to the carrier if installing. Then reverse the drive carrier removal procedure to install the drive, making sure you screw in the retention screw. Replace the top cover when finished.

Drive Cables

- The floppy disk drive cable has seven twisted wires.
- A color mark on a cable typically designates the location of pin 1.
- A single floppy disk drive ribbon cable has 34 wires and two connectors to provide for two floppy disk drives. The connector with twisted wires always connects to drive A, and the connector that does not have twisted wires always connects to drive B.

6-5 Power Supply

The SuperServer 6023P-i has a 400 watt power supply. This power supply has an auto-switching capability, which enables it to automatically sense and operate at either 110 or 220 volts. A power on/off switch is located at the back of the power supply. Turning this power switch to the off position will remove both main and standby power from the system.

Power Supply Failure

If the power supply unit fails, the system will shut down and you will need to replace the power supply unit. Replacement units can be ordered directly from Supermicro. See contact information in Chapter 1

Removing/Replacing the Power Supply

1. Removing the power supply:

First unplug the power cord from the system. Remove the chassis cover by pressing the two release buttons on the top of the chassis, near the front, and push the chassis top rearward about one inch. To remove the failed power unit, unplug the power cord that connects to the power supply. Then, remove all screws that connect the power supply to the chassis (two at the rear, two at the side, and one on the bottom). The power supply can then be lifted straight upward from the chassis.

2. Installing a new power supply:

Replace the failed unit with another unit of the same input voltage, output voltage and wattage. It is highly recommended to replace it with exactly the same model power supply. Carefully insert the new unit into position in the chassis and secure it with the five screws, as noted in the paragraph above. Before reconnecting the power cord, make certain that the power switch on the power supply is in the "off" position. Then reconnect the power cord, replace the chassis top cover and reposition the unit back into the rack. Finish by turning the power switch on the power supply "on", and then depress the power button on the chassis front panel.

Chapter 7

BIOS

7-1 Introduction

This chapter describes the PhoenixBIOS™ Setup utility for the X5DPi-G2. The Phoenix ROM BIOS is stored in a flash chip and can be easily upgraded using a floppy disk-based program.

Note: Due to periodic changes to the BIOS, some settings may have been added or deleted and might not yet be recorded in this manual. Please refer to the Manual Download area of the Supermicro web site <<http://www.supermicro.com>> for any changes to BIOS that may not be reflected in this manual.

System BIOS

The BIOS is the Basic Input Output System used in all IBM® PC, XT™, AT®, and PS/2® compatible computers. The PhoenixBIOS flash chip stores the system parameters, such type of disk drives, video displays, etc. in the CMOS. The CMOS memory requires very little electrical power. When the computer is turned off, a back-up battery provides power to the BIOS flash chip, enabling it to retain system parameters. Each time the computer is powered-on the computer is configured with the values stored in the BIOS ROM by the system BIOS, which gains control at boot-up.

How To Change the Configuration Data

The CMOS information that determines the system parameters may be changed by entering the BIOS Setup utility. This Setup utility can be accessed by pressing the <Delete> key at the appropriate time during system boot, see below.

Starting the Setup Utility

Normally, the only visible POST (Power On Self Test) routine is the memory test. As the memory is being tested, press the <Delete> key to enter the main menu of the BIOS Setup utility. From the main menu, you can access the other setup screens, such as the Security and Power menus. Beginning with Section 4-3, detailed descriptions are given for each parameter setting in the Setup utility.

7-2 Running Setup

**Default settings are in bold text unless otherwise noted.*

The BIOS setup options described in this section are selected by choosing the appropriate text from the main BIOS Setup screen. All displayed text is described in this section, although the screen display is often all you need to understand how to set the options (see on next page).

When you first power on the computer, the PhoenixBIOS™ is immediately activated.

While the BIOS is in control, the Setup program can be activated in one of two ways:

1. By pressing <Delete> immediately after turning the system on, or
2. When the message shown below appears briefly at the bottom of the screen during the POST (Power On Self-Test), press the <Delete> key to activate the main Setup menu:

Press the <Delete> key to enter Setup

7-3 Main BIOS Setup

All main Setup options are described in this section. The main BIOS Setup screen is displayed below.

Use the Up/Down arrow keys to move among the different settings in each menu. Use the Left/Right arrow keys to change the options for each setting.

Press the <Esc> key to exit the CMOS Setup Menu. The next section describes in detail how to navigate through the menus.

Items that use submenus are indicated with the ► icon. With the item highlighted, press the <Enter> key to access the submenu.

Main BIOS Setup Menu

Phoenix BIOS Setup Utility					
Main	Advanced	Security	Power	Boot	Exit
System Time				[16:19:20]	Item Specific Help
System Date				[02/02/02]	
Legacy Diskette A:				[1.44/1.25 MB]	
Legacy Diskette B:				[Not Installed]	
▶ Primary Master				[120 GB]	
▶ Primary Slave				[None]	
▶ Secondary Master				[CD-ROM]	
▶ Secondary Slave				[None]	
System Memory				256 MB	
Extended Memory				3967 KB	
F1 Help	↑↓	Select Item	-/+	Change Values	F9 Setup Defaults
Esc Exit	←	Select Menu	Enter	Select ▶ Sub-Menu	F10 Save and Exit

Main Setup Features

System Time

To set the system date and time, key in the correct information in the appropriate fields. Then press the <Enter> key to save the data.

System Date

Using the arrow keys, highlight the month, day and year fields and enter the correct data. Press the <Enter> key to save the data.

Legacy Diskette A

This setting allows the user to set the type of floppy disk drive installed as diskette A. The options are Disabled, 360Kb 5.25 in, 1.2MB 5.25 in, 720Kb 3.5 in, **1.44/1.25MB**, 3.5 in and 2.88MB 3.5 in.

Legacy Diskette B

This setting allows the user to set the type of floppy disk drive installed as diskette B. The options are **Disabled**, 360Kb 5.25 in, 1.2MB 5.25 in, 720Kb 3.5 in, 1.44/1.25MB, 3.5 in and 2.88MB 3.5 in.

► Primary Master/Primary Slave/Secondary Master/Secondary Slave

These settings allow the user to set the parameters of the IDE Primary Master/Slave and IDE Secondary Master/Slave slots. Hit <Enter> to activate the following sub-menu screen for detailed options of these items. Set the correct configurations accordingly. The items included in the sub-menu are:

Phoenix BIOS Setup Utility					
Main	Advanced	Security	Power	Boot	Exit
Type:		[Auto]			Item Specific Help
Multi Sector Transfer:		[16 Sectors]			Select the drive type of the fixed disk installed in your system. If type User is selected, Cylinders, Heads, and Sectors can be edited directly. Auto attempts to automatically detect the drive type for drives that comply with ANSI specifications.
LBA Mode Control:		[Enabled]			
32-bit I/O:		[Enabled]			
Transfer Mode:		[Fast PIO 4]			
Ultra DMA Mode		[Disabled]			
F1 Help	↑↓	Select Item	-/+	Change Values	F9 Setup Defaults
Esc Exit	↔	Select Menu	Enter	Select ► Sub-Menu	F10 Save and Exit

Type

Selects the type of IDE hard drive. The options are **Auto** (allows BIOS to automatically determine the hard drive's capacity, number of heads, etc.), a number from 1-39 to select a predetermined type of hard drive, CD-ROM and ATAPI Removable.

Multi-Sector Transfers

Select the number of transfer sectors. Options are 2, 4, 6, 8 and **16 Sectors**.

LBA Mode Control

This item determines whether Phoenix BIOS will access the IDE Primary Master Device via LBA mode. The options are **Enabled** and Disabled.

32-bit I/O

Selects 32-bit I/O operation. Options are Enabled and **Disabled**.

Transfer Mode

Selects the transfer mode. Options are Standard, Fast PIO1, Fast PIO2, Fast PIO3, **Fast PIO4**, FPIO3/DMA1 and FPIO4/DMA2.

Ultra DMA Mode

Selects Ultra DMA Mode. Options are **Disabled**, Mode 0, Mode 1, Mode 2, Mode 3, Mode 4 and Mode 5.

System Memory

This display informs you how much system memory is recognized as being present in the system.

Extended Memory

7-4 Advanced Setup

Choose Advanced from the Phoenix BIOS Setup Utility main menu with the arrow keys. You should see the following display. The items with a triangle beside them have sub menus that can be accessed by highlighting the item and pressing <Enter>. Options for PIR settings are displayed by highlighting the setting option using the arrow keys and pressing <Enter>. All Advanced BIOS Setup options are described in this section.

Phoenix BIOS Setup Utility					
Main	Advanced	Security	Power	Boot	Exit
Installed OS [Win95] Quick Boot Mode [Enabled] Quiet Boot [Disabled]				Item Specific Help	
Legacy USB Support [Enabled] Reset Configuration Data [No]					
<ul style="list-style-type: none"> ▶ Cache Memory ▶ I/O Device Configuration 					
Large Disk Access Mode [DOS]					
Local Bus IDE Adapter [Both]					
<ul style="list-style-type: none"> ▶ Advanced Chipset Control ▶ Advanced Processor Options ▶ DMI Event Logging ▶ Console Redirection 					
F1 Help ↑↓ Select Item -/+ Change Values F9 Setup Defaults Esc Exit ↔ Select Menu Enter Select ▶ Sub-Menu F10 Save and Exit					

Installed OS

This setting allows you to choose which operating system you are using to run the system. Options are Other, Win95, Win98, WinMe and Win2000.

Quick Boot Mode

If enabled, this feature will speed up the POST (Power On Self Test) routine after the computer is turned on. The settings are **Enabled** and Disabled. If Disabled, the POST routine will run at normal speed.

Quiet Boot

This setting allows you to Enable or **Disable** the diagnostic screen during boot-up.

Legacy USB Support

This setting allows you to enable support for Legacy USB devices. The settings are **Enabled** and Disabled.

Reset Configuration Data

Options are Yes and **No**. Choosing Yes will clear the Extended System Configuration Data (ECSD).

►Cache Memory

Access the submenu for this item to specify one of the following actions for various sections of cache memory: Uncache, Write Protect, Write Back, Write Through or Disable. See the "Item Specific Help" window for details.

►I/O Device Configuration

Access the submenu to make changes to the following settings.

Power Loss Control

This setting allows you to choose how the system will react when power returns after an unexpected loss of power. Options are Stay Off, Power On and **Last State**.

Serial Port A

This setting allows you to assign control of serial port A. The options are **Enabled** (user defined), Disabled, Auto (BIOS controlled) and OS Controlled.

Base I/O Address

Select the base I/O address for serial port A. The options are **3F8**, 2F8, 3E8 and 2E8.

Interrupt

Select the IRQ (interrupt request) for serial port A. Options are IRQ3 and **IRQ4**.

Serial Port B

This setting allows you to assign control of serial port B. The options are **Enabled** (user defined), Disabled, Auto (BIOS controlled) and OS Controlled.

Mode

Specify the type of device that will be connected to serial port B. Options are **Normal** and IR (for an infrared device).

Base I/O Address

Select the base I/O address for serial port B. The options are 3F8, **2F8**, 3E8 and 2E8.

Interrupt

Select the IRQ (interrupt request) for serial port B. Options are **IRQ3** and IRQ4.

Parallel Port

This setting allows you to assign control of the parallel port. The options are **Enabled** (user defined), Disabled and Auto (BIOS controlled).

Base I/O Address

Select the base I/O address for the parallel port. The options are **378**, 278 and 3BC.

Interrupt

Select the IRQ (interrupt request) for the parallel port. Options are IRQ5 and **IRQ7**.

Mode

Specify the parallel port mode. Options are Output Only, Bi-directional, EPP and **ECP**.

DMA Channel

Specify the DMA channel. Options are DMA1 and **DMA3**.

Floppy Disk Controller

This setting allows you to assign control of the floppy disk controller. The options are **Enabled** (user defined), Disabled and Auto (BIOS controlled).

Base I/O Address

Select the base I/O address for the parallel port. The options are **Primary** and Secondary.

Large Disk Access Mode

This setting determines how large hard drives are to be accessed. The options are **DOS** or Other (for Unix, Novell NetWare and other operating systems).

Local Bus IDE Adapter

Use this setting to enable the integrated local bus IDE adapter. Options are Disable, Primary, Secondary and **Both**.

► Advanced Chipset Control

Access the submenu to make changes to the following settings.

Enable Memory Gap

This setting allows you to turn off system RAM to free up address space. The options for this setting are **Disabled** and Extended.

ECC Configuration

This setting lets you enable or disable ECC (Error Correction and Checking). The options are **ECC** and Disabled.

ECC Error Type

This setting lets you select which type of interrupt will be activated as a result of an ECC error. The options are **None**, NMI (Non-Maskable Interrupt), SMI (System Management Interrupt) and SCI (System Control Interrupt).

SERR Signal Condition

This setting specifies the conditions required to qualify as an ECC error. Options are **None**, Single Bit, Multiple Bit and Both.

►Advanced Processor Options

Access the submenu to make changes to the following settings.

CPU Speed

This is a display that indicates the speed of the installed processor.

Frequency Ratio

This setting allows you to specify the value of the internal frequency multiplier of the processor, which is used to determine the processor speed. Options are x8, x16, x17, x18, x19 and x20.

Fast String Operations

This setting allows you to **Enable** or Disable fast string operations.

Compatible FPU Code

This setting allows you to Enable or **Disable** the compatible FPU code.

Split Lock Operations

This setting allows you to **Enable** or Disable split lock operations.

Hyper-threading

This setting allows you to **Enable** or Disable hyper-threading. Enabling hyper-threading results in increased CPU performance.

L3 Cache

This setting allows you to Enable or **Disable** the L3 cache.

►DMI Event Logging

Access the submenu to make changes to the following settings.

Event Log Validity

This is a display, not a setting, informing you of the event log validity.

Event Log Capacity

This is a display, not a setting, informing you of the event log capacity.

View DMI Event Log

Highlight this item and press <Enter> to view the contents of the event log.

Event Logging

This setting allows you to **Enable** or Disable event logging.

Event Logging

This setting allows you to **Enable** or Disable ECC event logging.

Mark DMI Events as Read

Highlight this item and press <Enter> to mark the DMI events as read.

Clear All DMI Event Logs

Highlight this item and press <Enter> to clear all DMI event logs.

► Console Redirection

Access the submenu to make changes to the following settings.

COM Port Address

Specifies to redirect the console to On-board COMA or On-board COMB. This setting can also be **Disabled**.

BAUD Rate

Select the BAUD rate for console redirection.

Console Type

Choose from the available options to select the console type for console redirection.

Flow Control

Choose from the available options to select the flow control for console redirection.

Console Connection

Select the console connection: either Direct or Via Modem.

Continue CR after POST

Choose whether to continue with console redirection after the POST routine. Options are On and **Off**.

of Video Pages to Support

Choose the number of video pages to allocate for redirection when video hardware is not available. Options are 1, 2, 3, 4, 5, 6, 7 and 8.

7-5 Security

Choose Security from the Phoenix BIOS Setup Utility main menu with the arrow keys. You should see the following display. Security setting options are displayed by highlighting the setting using the arrow keys and pressing <Enter>. All Security BIOS settings are described in this section.

Phoenix BIOS Setup Utility					
Main	Advanced	Security	Power	Boot	Exit
Supervisor Password Is: [Clear] User Password Is: [Clear] Quiet Boot [Disabled] Set Supervisor Password [Enter] Set User Password [Enter] Password on Boot [Disabled] Fixed Disk Boot Sector [Normal]				Item Specific Help	
F1 Help	↑↓	Select Item	-/+	Change Values	F9 Setup Defaults
Esc Exit	↔	Select Menu	Enter	Select ▶ Sub-Menu	F10 Save and Exit

Supervisor Password Is:

This displays whether a supervisor password has been entered for the system. Clear means such a password has not been used and Set means a supervisor password has been entered for the system.

User Password Is:

This displays whether a user password has been entered for the system. Clear means such a password has not been used and Set means a user password has been entered for the system.

Set Supervisor Password

When the item "Set Supervisor Password" is highlighted, hit the <Enter> key. When prompted, type the Supervisor's password in the dialogue box to set or to change supervisor's password, which allows access to BIOS.

Set User Password

When the item "Set User Password" is highlighted, hit the <Enter> key. When prompted, type the user's password in the dialogue box to set or to change the user's password, which allows access to the system at boot-up.

Password on Boot

This setting allows you to require a password to be entered when the system boots up. Options are Enabled (password required) and Disabled (password not required).

Fixed Disk Boot Sector

This setting may offer some protection against viruses when set to Write Protect, which protects the boot sector on the hard drive from having a virus written to it. The other option is **Normal**.

7-6 Power

Choose Power from the Phoenix BIOS Setup Utility main menu with the arrow keys. You should see the following display. Power setting options are displayed by highlighting the setting using the arrow keys and pressing <Enter>. All Power BIOS settings are described in this section.

Phoenix BIOS Setup Utility					
Main	Advanced	Security	Power	Boot	Exit
ACPI Mode: [Enabled] Power Savings: [Customized] Standby Timeout: [Off] Auto Suspend Timeout: [Off] Resume On Time: [Off] Resume Time: [00:00:00] Resume on Modem Ring: [Off]				Item Specific Help	
F1 Help	↑↓	Select Item	-/+	Change Values	F9 Setup Defaults
Esc Exit	↔	Select Menu	Enter	Select ▶ Sub-Menu	F10 Save and Exit

ACPI Mode

Use the setting to determine if you want to employ ACPI (Advanced Configuration and Power Interface) power management on your system.

Power Savings

This setting sets the degree of power saving for the system. The options are Disabled, **Customized**, Maximum Power Savings and Maximum Performance. Customized allows you to alter the other two modes.

Standby Timeout

Use this setting to specify the period of system inactivity to transpire before entering the standby state. Options are **Off**, 16 sec, 32 sec, 48 sec, 1 min, 2 min, 4 min and 8 min.

Auto Suspend Timeout

Use this setting to specify the period of system inactivity to transpire before entering the suspend state. Options are **Off**, 5 min, 10 min, 15 min, 20 min, 30 min, 40 min and 60 min.

Resume on Time

Select either **Off** or **On**, which will wake the system up at the time specified in the next setting.

Resume Time

Use this setting to specify the time you want the system to wake up (the above setting must be set to **On**). Enter the time with the number keys.

Resume on Modem Ring

Use this setting to enable or disable the WOR (Wake-on Ring) feature. Options are **On** and **Off**.

7-7 Boot

Choose Boot from the Phoenix BIOS Setup Utility main menu with the arrow keys. You should see the following display. Highlighting a setting with a + or - will expand or collapse that entry. See details on how to change the order and specs of boot devices in the Item Specific Help window. All Boot BIOS settings are described in this section.

Phoenix BIOS Setup Utility					
Main	Advanced	Security	Power	Boot	Exit
+Removable Devices CD-ROM Drive +Hard Drive Network Boot Intel UNDI, PXE-2.0 Intel UNDI, PXE-2.0				Item Specific Help	
F1 Help	↑↓	Select Item	-/+	Change Values	F9 Setup Defaults
Esc Exit	↔	Select Menu	Enter	Select ▶ Sub-Menu	F10 Save and Exit

+Removable Devices

Highlight and press <Enter> to expand the field. See details on how to change the order and specs of removable devices in the Item Specific Help window.

CD-ROM Drive

See details on how to change the order and specs of removable devices in the Item Specific Help window.

+Hard Drive

Highlight and press <Enter> to expand the field. See details on how to change the order and specs of hard drives in the Item Specific Help window.

Network Boot

See details on how to change the order and specs of network boot devices in the Item Specific Help window.

Intel UNDI, PXE-2.0

See details on how to change the order and specs of Intel UNDI devices in the Item Specific Help window.

7-8 PIR

Choose PIR from the Phoenix BIOS Setup Utility main menu with the arrow keys. You should see the following display. The items with a triangle beside them have sub menus that can be accessed by highlighting the item and pressing <Enter>. PIR stands for "Processor Info ROM", which allows BIOS to read certain information from the processors. Options for PIR settings are displayed by highlighting the setting option using the arrow keys and pressing <Enter>. All PIR BIOS Setup options are described in this section.

Phoenix BIOS Setup Utility						
Main	Advanced	Security	Power	Boot	PIR	Exit
Select the Processor's PIR Select the Thermal Unit ▶ Processor Info ROM Data ▶ Hardware Monitor Logic					Item Specific Help	
F1 Help	↑↓	Select Item	-/+	Change Values	F9 Setup Defaults	
Esc Exit	←	Select Menu	Enter	Select ▶	Sub-Menu F10 Save and Exit	

Select the Processor's PIR

Selects the processor PIR. Options are **A0h/A1h**, A2h/A3h, A4h/A5h, A6h/A7h, A8h/A8h, AAh/ABh, ACh/ADh and AEh/AFh.

Select the Thermal Unit

Selects the thermal unit. Options are **30h/31h**, 32h/33h, 34h/35h, 52h/53h, 54h/55h, 56h/57h, 98h/99h, 9Ah/9Bh and 9Ch/9Dh.

► **Processor Info ROM Data**

Highlight this and hit <Enter> to see PIR data on the following items:

Header Info

Processor Data

Processor Core Data

L3 Cache Data

Package Data

Part Number Data

Thermal Reference Data

Feature Data

Other Data

OEM Data

► **Hardware Monitor Logic**

Highlight this and hit <Enter> to see monitor data for the following items:

CPU1 Temperature

CPU2 Temperature

System Temperature

CPU Fan1/CPU1 Chassis Fan

CPU Fan2/CPU2 Chassis Fan

Chassis Fan 1

Chassis Fan 2**Processor Vcore****3.3V Standby****3.3V Vcc****5V Vcc****12V Vcc****1.8V Vcc****-12V Vcc****7-9 Exit**

Choose Exit from the Phoenix BIOS Setup Utility main menu with the arrow keys. You should see the following display. All Exit BIOS settings are described in this section.

Phoenix BIOS Setup Utility					
Main	Advanced	Security	Power	Boot	PIR Exit
Exit Saving Changes Exit Discarding Changes Load Setup Defaults Discard Changes Save Changes					Item Specific Help
F1 Help	↑↓	Select Item	-/+	Change Values	F9 Setup Defaults
Esc Exit	↔	Select Menu	Enter	Select ▶ Sub-Menu	F10 Save and Exit

Exit Saving Changes

Highlight this item and hit <Enter> to save any changes you made and to exit the BIOS Setup utility.

Exit Discarding Changes

Highlight this item and hit <Enter> to exit the BIOS Setup utility without saving any changes you may have made.

Load Setup Defaults

Highlight this item and hit <Enter> to load the default settings for all items in the BIOS Setup. These are the safest settings to use.

Discard Changes

Highlight this item and hit <Enter> to discard (cancel) any changes you made. You will remain in the Setup utility.

Save Changes

Highlight this item and hit <Enter> to save any changes you made. You will remain in the Setup utility.

Appendix A

BIOS POST Messages

During the Power-On Self-Test (POST), the BIOS will check for problems. If a problem is found, the BIOS will activate an alarm or display a message. The following is a list of such BIOS messages.

Failure Fixed Disk

Fixed disk is not working or not configured properly. Check to see if fixed disk is attached properly. Run Setup. Find out if the fixed-disk type is correctly identified.

Stuck key

Stuck key on keyboard.

Keyboard error

Keyboard not working.

Keyboard Controller Failed

Keyboard controller failed test. May require replacing keyboard controller.

Keyboard locked - Unlock key switch

Unlock the system to proceed.

Monitor type does not match CMOS - Run SETUP

Monitor type not correctly identified in Setup

Shadow Ram Failed at offset: nnnn

Shadow RAM failed at offset **nnnn** of the 64k block at which the error was detected.

System RAM Failed at offset: nnnn

System RAM failed at offset **nnnn** of in the 64k block at which the error was detected.

Extended RAM Failed at offset: nnnn Extended memory not working or not configured properly at offset **nnnn**.

System battery is dead - Replace and run SETUP

The CMOS clock battery indicator shows the battery is dead. Replace the battery and run Setup to reconfigure the system.

System CMOS checksum bad - Default configuration used

System CMOS has been corrupted or modified incorrectly, perhaps by an application program that changes data stored in CMOS. The BIOS installed Default Setup Values. If you do not want these values, enter Setup and enter your own values. If the error persists, check the system battery or contact your dealer.

System timer error

The timer test failed. Requires repair of system board.

Real time clock error

Real-Time Clock fails BIOS hardware test. May require board repair.

Check date and time settings

BIOS found date or time out of range and reset the Real-Time Clock. May require setting legal date (1991-2099).

Previous boot incomplete - Default configuration used

Previous POST did not complete successfully. POST loads default values and offers to run Setup. If the failure was caused by incorrect values and they are not corrected, the next boot will likely fail. On systems with control of **wait states**, improper Setup settings can also terminate POST and cause this error on the next boot. Run Setup and verify that the waitstate configuration is correct. This error is cleared the next time the system is booted.

Memory Size found by POST differed from CMOS

Memory size found by POST differed from CMOS.

Diskette drive A error

Diskette drive B error

Drive A: or B: is present but fails the BIOS POST diskette tests. Check to see that the drive is defined with the proper diskette type in Setup and that the diskette drive is attached correctly.

Incorrect Drive A type - run SETUP

Type of floppy drive A: not correctly identified in Setup.

Incorrect Drive B type - run SETUP

Type of floppy drive B: not correctly identified in Setup.

System cache error - Cache disabled

RAM cache failed and BIOS disabled the cache. On older boards, check the cache jumpers. You may have to replace the cache. See your dealer. A disabled cache slows system performance considerably.

CPUID:

CPU socket number for Multi-Processor error.

EISA CMOS not writeable

ServerBIOS2 test error: Cannot write to EISA CMOS.

DMA Test Failed

ServerBIOS2 test error: Cannot write to extended **DMA** (Direct Memory Access) registers.

Software NMI Failed

ServerBIOS2 test error: Cannot generate software NMI (Non-Maskable Interrupt).

Fail-Safe Timer NMI Failed

ServerBIOS2 test error: Fail-Safe Timer takes too long.

device Address Conflict

Address conflict for specified **device**.

Allocation Error for: device

Run ISA or EISA Configuration Utility to resolve resource conflict for the specified **device**.

CD ROM Drive

CD ROM Drive identified.

Entering SETUP ...

Starting Setup program

Failing Bits: nnnn

The hex number **nnnn** is a map of the bits at the RAM address which failed the memory test. Each 1 (one) in the map indicates a failed bit. See errors 230, 231, or 232 above for offset address of the failure in System, Extended, or Shadow memory.

Fixed Disk n

Fixed disk n (0-3) identified.

Invalid System Configuration Data

Problem with NVRAM (CMOS) data.

I/O device IRQ conflict

I/O device IRQ conflict error.

PS/2 Mouse Boot Summary Screen:

PS/2 Mouse installed.

nnnn kB Extended RAM Passed

Where nnnn is the amount of RAM in kilobytes successfully tested.

nnnn Cache SRAM Passed

Where nnnn is the amount of system cache in kilobytes successfully tested.

nnnn kB Shadow RAM Passed

Where nnnn is the amount of shadow RAM in kilobytes successfully tested.

nnnn kB System RAM Passed

Where nnnn is the amount of system RAM in kilobytes successfully tested.

One or more I2O Block Storage Devices were excluded from the Setup Boot Menu

There was not enough room in the IPL table to display all installed I2O block-storage devices.

Operating system not found

Operating system cannot be located on either drive A: or drive C:. Enter Setup and see if fixed disk and drive A: are properly identified.

Parity Check 1 nnnn

Parity error found in the system bus. BIOS attempts to locate the address and display it on the screen. If it cannot locate the address, it displays ?????. Parity is a method for checking errors in binary data. A parity error indicates that some data has been corrupted.

Parity Check 2 nnnn

Parity error found in the I/O bus. BIOS attempts to locate the address and display it on the screen. If it cannot locate the address, it displays **????**.

Press <F1> to resume, <F2> to Setup, <F3> for previous

Displayed after any recoverable error message. Press <F1> to start the boot process or <F2> to enter Setup and change the settings. Press <F3> to display the previous screen (usually an initialization error of an **Option ROM**, i.e., an add-on card). Write down and follow the information shown on the screen.

Press <F2> to enter Setup

Optional message displayed during POST. Can be turned off in Setup.

PS/2 Mouse:

PS/2 mouse identified.

Run the I2O Configuration Utility

One or more unclaimed block storage devices have the Configuration Request bit set in the LCT. Run an I2O Configuration Utility (e.g. the SAC utility).

System BIOS shadowed

System BIOS copied to shadow RAM.

UMB upper limit segment address: nnnn

Displays the address **nnnn** of the upper limit of **Upper Memory Blocks**, indicating released segments of the BIOS which can be reclaimed by a virtual memory manager.

Video BIOS shadowed

Video BIOS successfully copied to shadow RAM.

Notes

Appendix B

BIOS POST Codes

This section lists the POST (Power On Self Test) codes for the PhoenixBIOS. POST codes are divided into two categories: recoverable and terminal.

Recoverable POST Errors

When a recoverable type of error occurs during POST, the BIOS will display an POST code that describes the problem. BIOS may also issue one of the following beep codes:

- 1 long and two short beeps - video configuration error
- 1 continuous long beep - no memory detected

Terminal POST Errors

If a terminal type of error occurs, BIOS will shut down the system. Before doing so, BIOS will write the error to port 80h, attempt to initialize video and write the error in the top left corner of the screen.

The following is a list of codes that may be written to port 80h.

POST Code	Description
02h	Verify Real Mode
03h	Disable Non-Maskable Interrupt (NMI)
04h	Get CPU type
06h	Initialize system hardware
07h	Disable shadow and execute code from the ROM.
08h	Initialize chipset with initial POST values
09h	Set IN POST flag
0Ah	Initialize CPU registers
0Bh	Enable CPU cache
0Ch	Initialize caches to initial POST values
0Eh	Initialize I/O component
0Fh	Initialize the local bus IDE
10h	Initialize Power Management
11h	Load alternate registers with initial POST values
12h	Restore CPU control word during warm boot
13h	Initialize PCI Bus Mastering devices

POST Code	Description
14h	Initialize keyboard controller
16h	1-2-2-3 BIOS ROM checksum
17h	Initialize cache before memory Auto size
18h	8254 timer initialization
1Ah	8237 DMA controller initialization
1Ch	Reset Programmable Interrupt Controller
20h	1-3-1-1 Test DRAM refresh
22h	1-3-1-3 Test 8742 Keyboard Controller
24h	Set ES segment register to 4 GB
28h	Auto size DRAM
29h	Initialize POST Memory Manager
2Ah	Clear 512 kB base RAM
2Ch	1-3-4-1 RAM failure on address line xxxx*
2Eh	1-3-4-3 RAM failure on data bits xxxx* of low byte of memory bus
2Fh	Enable cache before system BIOS shadow
32h	Test CPU bus-clock frequency
33h	Initialize Phoenix Dispatch Manager
36h	Warm start shut down
38h	Shadow system BIOS ROM
3Ah	Auto size cache
3Ch	Advanced configuration of chipset registers
3Dh	Load alternate registers with CMOS values
41h	Initialize extended memory for RomPilot
42h	Initialize interrupt vectors
45h	POST device initialization
46h	2-1-2-3 Check ROM copyright notice
47h	Initialize I20 support
48h	Check video configuration against CMOS
49h	Initialize PCI bus and devices
4Ah	Initialize all video adapters in system
4Bh	QuietBoot start (optional)
4Ch	Shadow video BIOS ROM
4Eh	Display BIOS copyright notice
4Fh	Initialize MultiBoot
50h	Display CPU type and speed
51h	Initialize EISA board
52h	Test keyboard
54h	Set key click if enabled
55h	Enable USB devices
58h	2-2-3-1 Test for unexpected interrupts

POST Code	Description
59h	Initialize POST display service
5Ah	Display prompt "Press F2 to enter SETUP"
5Bh	Disable CPU cache
5Ch	Test RAM between 512 and 640 kB
60h	Test extended memory
62h	Test extended memory address lines
64h	Jump to UserPatch1
66h	Configure advanced cache registers
67h	Initialize Multi Processor APIC
68h	Enable external and CPU caches
69h	Setup System Management Mode (SMM) area
6Ah	Display external L2 cache size
6Bh	Load custom defaults (optional)
6Ch	Display shadow-area message
6Eh	Display possible high address for UMB recovery
70h	Display error messages
72h	Check for configuration errors
76h	Check for keyboard errors
7Ch	Set up hardware interrupt vectors
7Dh	Initialize Intelligent System Monitoring
7Eh	Initialize coprocessor if present
80h	Disable onboard Super I/O ports and IRQs
81h	Late POST device initialization
82h	Detect and install external RS232 ports
83h	Configure non-MCD IDE controllers
84h	Detect and install external parallel ports
85h	Initialize PC-compatible PnP ISA devices
86h	Re-initialize onboard I/O ports.
87h	Configure Motherboard Configurable Devices (optional)
88h	Initialize BIOS Data Area
89h	Enable Non-Maskable Interrupts (NMIs)
8Ah	Initialize Extended BIOS Data Area
8Bh	Test and initialize PS/2 mouse
8Ch	Initialize floppy controller
8Fh	Determine number of ATA drives (optional)
90h	Initialize hard-disk controllers
91h	Initialize local-bus hard-disk controllers
92h	Jump to UserPatch2
93h	Build MPTABLE for multi-processor boards
95h	Install CD ROM for boot
96h	Clear huge ES segment register

POST Code	Description
97h	Fix up Multi Processor table
98h	1-2 Search for option ROMs. One long, two short beeps on checksum failure
99h	Check for SMART Drive (optional)
9Ah	Shadow option ROMs
9Ch	Set up Power Management
9Dh	Initialize security engine (optional)
9Eh	Enable hardware interrupts
9Fh	Determine number of ATA and SCSI drives
A0h	Set time of day
A2h	Check key lock
A4h	Initialize typematic rate
A8h	Erase F2 prompt
AAh	Scan for F2 key stroke
ACh	Enter SETUP
AEh	Clear Boot flag
B0h	Check for errors
B1h	Inform RomPilot about the end of POST.
B2h	POST done - prepare to boot operating system
B4h	1 One short beep before boot
B5h	Terminate QuietBoot (optional)
B6h	Check password (optional)
B7h	Initialize ACPI BIOS
B9h	Prepare Boot
BAh	Initialize SMBIOS
BBh	Initialize PnP Option ROMs
BCh	Clear parity checkers
BDh	Display MultiBoot menu
BEh	Clear screen (optional)
BFh	Check virus and backup reminders
C0h	Try to boot with INT 19
C1h	Initialize POST Error Manager (PEM)
C2h	Initialize error logging
C3h	Initialize error display function
C4h	Initialize system error handler
C5h	PnPnd dual CMOS (optional)
C6h	Initialize note dock (optional)
C7h	Initialize note dock late
C8h	Force check (optional)
C9h	Extended checksum (optional)
CAh	Redirect Int 15h to enable remote keyboard

POST Code	Description
CBh	Redirect Int 13h to Memory Technologies Devices such as ROM, RAM, PCMCIA, and serial disk
CCh	Redirect Int 10h to enable remote serial video
CDh	Re-map I/O and memory for PCMCIA
CEh	Initialize digitizer and display message
D2h	Unknown interrupt

The following are for boot block in Flash ROM

POST Code	Description
E0h	Initialize the chipset
E1h	Initialize the bridge
E2h	Initialize the CPU
E3h	Initialize system timer
E4h	Initialize system I/O
E5h	Check force recovery boot
E6h	Checksum BIOS ROM
E7h	Go to BIOS
E8h	Set Huge Segment
E9h	Initialize Multi Processor
EAh	Initialize OEM special code
EBh	Initialize PIC and DMA
ECh	Initialize Memory type
EDh	Initialize Memory size
EEh	Shadow Boot Block
EFh	System memory test
F0h	Initialize interrupt vectors
F1h	Initialize Run Time Clock
F2h	Initialize video
F3h	Initialize System Management Manager
F4h	Output one beep
F5h	Clear Huge Segment
F6h	Boot to Mini DOS
F7h	Boot to Full DOS

* If the BIOS detects error 2C, 2E, or 30 (base 512K RAM error), it displays an additional word-bitmap (xxxx) indicating the address line or bits that failed. For example, "2C 0002" means address line 1 (bit one set) has failed. "2E 1020" means data bits 12 and 5 (bits 12 and 5 set) have failed in the lower 16 bits. The BIOS also sends the bitmap to the port-80 LED display. It first displays the checkpoint code, followed by a delay, the high-order byte, another delay, and then the loworder byte of the error. It repeats this sequence continuously.

Notes

Appendix C

Supero Doctor III

C-1 Overview

The Supero Doctor III program is a Web-based management tool that supports remote management capability and includes both Remote and Local Management tools. The local management is called the SD III Client. The Supero Doctor III program included on the CD-ROM that came with your motherboard allows you to monitor the environment and operations of your system. Supero Doctor III displays crucial system information such as CPU temperature, system voltages and fan status.

Key Features

For Windows XP, NT4, 2000 and 2003 Operating Systems

Supero Doctor III supports the following features:

- Web-based remote management
- Graphical Mode Console Redirection
- System Information (WMI)
- Performance Monitoring
- Remote Control
 - Graceful power shutdown and reboot
 - Hard power shutdown and reset without notice
- System Management
 - Allows you to easily manage your entire network
- Reports
 - System Information
 - Health Log
 - Administration
 - System Management

Linux Support

The SD III Client and Supero Doctor II for Linux support the following features:*

- Applications for local management
- Pager and E-mail alerts
- SNMP support
- Health Monitoring
 - CPU and system temperatures
 - System voltages
 - CPU and chassis fans
 - Chassis intrusion
 - Redundant power failure (hardware dependant)

Note: For Linux operating systems, please refer to the Supero Doctor II information posted on our website.

The figures below display two of the key features of SDIII.

Figure C-1. Supero Doctor III Health Information Screen



Figure C-2. Supero Doctor III Remote Power/Reset Control Screen



Note: SD III software can be downloaded from our website at <ftp://ftp.supermicro.com/utility/>. You can also download the SDIII User's Guide from the ftp site. For Linux, we recommend the use of Supero Doctor II.

Notes

Appendix D

System Specifications

Processors

Single or dual Intel® Xeon™ processors to 3.20 GHz at a front side (system) bus speed of 533/400 MHz.

Note: Please refer to the support section of our web site for a complete listing of supported processors. (<http://www.supermicro.com/support/>)

Chipset

Intel E7501 chipset

BIOS

4 Mb Phoenix® Flash ROM

Memory Capacity

Eight 184-pin DDR DIMM sockets supporting up to 16 GB of registered ECC DDR-266/200 (PC2100/1600) SDRAM

Note: Interleaved memory - requires memory to be installed two at a time. See the memory section in Chapter 5 for details.

Peripheral Drive Bays

One (1) 3.5" floppy drive
One (1) 5.25" drive bay
One (1) slim CD-ROM drive
Six (6) internal 3.5" drive bays

Expansion Slots

One SXB slot with riser card for supporting three (3) 64-bit, full-size (standard) PCI-X cards

Power Supply

Type: 1 x 400W with +3.3V, +5V, +12V, -5V and -12V main DC outputs and a 5V standby output

Input Voltage: 100-220VAC with PFC ($\pm 10\%$ tolerance - units are auto-switching capable)

Input Frequency: 50/60Hz

Maximum Output: +5V and +3.3V: 45A total
+5V, +3.3V and +12V: 385W total

System Cooling

Four 8-cm ball-bearing fans

Operating Environment

Operating Temperature Range: 0 to 35 degrees C

Humidity Range: 5-90%, non-condensing

Form Factor

X5DPi-G2 serverboard: Ext. ATX (12 x 13.05 in/304.8 x 331.5 mm)

SC822 chassis: 2U rackmount

Operating Systems Supported

Windows NT, Windows 2000, Solaris, Netware, SCO UNIX and Linux

Dimensions

16.7 x 3.46 x 25.7 in.; 425 x 88 x 652 mm (W x H x D)

Weight

Net (Bare Bone): ~43 lbs. (19.5 kg.)

Gross (Bare Bone): ~54 lbs. (24.5 kg.)

Regulatory Compliance

Electromagnetic Emissions:

FCC Class B, EN 55022 Class B, EN 61000-3-2 & -3-3, CISPR 22 Class B

Electromagnetic Immunity:

EN 55024/CISPR 24, (EN 61000-4-2, EN 61000-4-3, EN 61000-4-4, EN 61000-4-5, EN 61000-4-6, EN 61000-4-8, EN 61000-4-11)

Safety:

EN 60950/IEC 60950-Compliant

UL Listed (USA)

CUL Listed (Canada)

TUV Certified (Germany)

CE Marking (Europe)