

SUPERO[®]

SUPERSERVER 6025W-NTR+

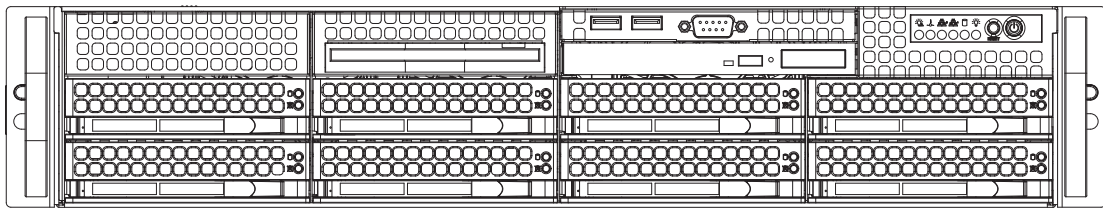

USER'S MANUAL

1.0a

The information in this User's Manual has been carefully reviewed and is believed to be accurate. The vendor assumes no responsibility for any inaccuracies that may be contained in this document, makes no commitment to update or to keep current the information in this manual, or to notify any person or organization of the updates. **Please Note: For the most up-to-date version of this manual, please see our web site at www.supermicro.com.**

Super Micro Computer, Inc. ("Supermicro") reserves the right to make changes to the product described in this manual at any time and without notice. This product, including software, if any, and documentation may not, in whole or in part, be copied, photocopied, reproduced, translated or reduced to any medium or machine without prior written consent.

IN NO EVENT WILL SUPERMICRO BE LIABLE FOR DIRECT, INDIRECT, SPECIAL, INCIDENTAL, SPECULATIVE OR CONSEQUENTIAL DAMAGES ARISING FROM THE USE OR INABILITY TO USE THIS PRODUCT OR DOCUMENTATION, EVEN IF ADVISED OF THE POSSIBILITY OF SUCH DAMAGES. IN PARTICULAR, SUPERMICRO SHALL NOT HAVE LIABILITY FOR ANY HARDWARE, SOFTWARE, OR DATA STORED OR USED WITH THE PRODUCT, INCLUDING THE COSTS OF REPAIRING, REPLACING, INTEGRATING, INSTALLING OR RECOVERING SUCH HARDWARE, SOFTWARE, OR DATA.

Any disputes arising between manufacturer and customer shall be governed by the laws of Santa Clara County in the State of California, USA. The State of California, County of Santa Clara shall be the exclusive venue for the resolution of any such disputes. Super Micro's total liability for all claims will not exceed the price paid for the hardware product.

FCC Statement: This equipment has been tested and found to comply with the limits for a Class A digital device pursuant to Part 15 of the FCC Rules. These limits are designed to provide reasonable protection against harmful interference when the equipment is operated in a commercial environment. This equipment generates, uses, and can radiate radio frequency energy and, if not installed and used in accordance with the manufacturer's instruction manual, may cause harmful interference with radio communications. Operation of this equipment in a residential area is likely to cause harmful interference, in which case you will be required to correct the interference at your own expense.

WARNING: Handling of lead solder materials used in this product may expose you to lead, a chemical known to the State of California to cause birth defects and other reproductive harm.

Manual Revision 1.0a

Release Date: November 4, 2008

Unless you request and receive written permission from Super Micro Computer, Inc., you may not copy any part of this document.

Information in this document is subject to change without notice. Other products and companies referred to herein are trademarks or registered trademarks of their respective companies or mark holders.

Copyright © 2008 by Super Micro Computer, Inc.
All rights reserved.

Printed in the United States of America

Preface

About This Manual

This manual is written for professional system integrators and PC technicians. It provides information for the installation and use of the SuperServer 6025W-NTR+. Installation and maintenance should be performed by experienced technicians only.

The SuperServer 6025W-NTR+ is a high-end server based on the SC825TQ-R700LP 2U rackmount chassis and the X7DWN+, a dual processor serverboard that supports dual Intel® Xeon™ LGA 771 processors and up to 128 GB of registered FBD ECC DDR2-800/667/533 SDRAM.

Manual Organization

Chapter 1: Introduction

The first chapter provides a checklist of the main components included with the server system and describes the main features of the X7DWN+ serverboard and the SC825TQ-R700LP chassis, which comprise the SuperServer 6025W-NTR+.

Chapter 2: Server Installation

This chapter describes the steps necessary to install the SuperServer 6025W-NTR+ into a rack and check out the server configuration prior to powering up the system. If your server was ordered without processor and memory components, this chapter will refer you to the appropriate sections of the manual for their installation.

Chapter 3: System Interface

Refer here for details on the system interface, which includes the functions and information provided by the control panel on the chassis as well as other LEDs located throughout the system.

Chapter 4: System Safety

You should thoroughly familiarize yourself with this chapter for a general overview of safety precautions that should be followed when installing and servicing the SuperServer 6025W-NTR+.

Chapter 5: Advanced Serverboard Setup

Chapter 5 provides detailed information on the X7DWN+ serverboard, including the locations and functions of connections, headers and jumpers. Refer to this chapter when adding or removing processors or main memory and when reconfiguring the serverboard.

Chapter 6: Advanced Chassis Setup

Refer to Chapter 6 for detailed information on the SC825TQ-R700LP server chassis. You should follow the procedures given in this chapter when installing, removing or reconfiguring SATA or peripheral drives and when replacing system power supply units and cooling fans.

Chapter 7: BIOS

The BIOS chapter includes an introduction to BIOS and provides detailed information on running the CMOS Setup Utility.

Appendix A: BIOS POST Messages

Appendix B: BIOS POST Codes

Appendix C: Intel HostRaid Setup Guidelines

Appendix D: Adaptec HostRaid Setup Guidelines

Appendix E: System Specifications

Table of Contents

Chapter 1 Introduction

1-1	Overview	1-1
1-2	Serverboard Features	1-2
	Processors	1-2
	Memory	1-2
	Serial ATA	1-2
	PCI Expansion Slots	1-2
	UIO	1-2
	Onboard Controllers/Ports	1-3
	ATI Graphics Controller	1-3
	Other Features	1-3
1-3	Server Chassis Features	1-3
	System Power	1-3
	Serial ATA Subsystem	1-3
	Front Control Panel	1-4
	I/O Backplane	1-4
	Cooling System	1-4
1-4	Contacting Supermicro	1-6

Chapter 2 Server Installation

2-1	Overview	2-1
2-2	Unpacking the System	2-1
2-3	Preparing for Setup	2-1
	Choosing a Setup Location	2-1
	Rack Precautions	2-2
	Server Precautions	2-2
	Rack Mounting Considerations	2-3
	Ambient Operating Temperature	2-3
	Reduced Airflow	2-3
	Mechanical Loading	2-3
	Circuit Overloading	2-3
	Reliable Ground	2-3
2-4	Installing the System into a Rack	2-4
	Identifying the Sections of the Rack Rails	2-4
	Installing the Chassis Rails	2-4
	Installing the Rack Rails:	2-6
	Installing the Server into the Rack	2-6

Installing the Server into a Telco Rack	2-6
2-5 Checking the Serverboard Setup.....	2-8
2-6 Checking the Drive Bay Setup.....	2-10

Chapter 3 System Interface

3-1 Overview	3-1
3-2 Control Panel Buttons	3-1
Reset	3-1
Power	3-1
3-3 Control Panel LEDs	3-2
Power Fail	3-2
Overheat/Fan Fail:	3-2
NIC1	3-2
NIC2	3-2
HDD.....	3-3
Power	3-3
3-4 Drive Carrier LEDs.....	3-3

Chapter 4 System Safety

4-1 Electrical Safety Precautions	4-1
4-2 General Safety Precautions	4-2
4-3 ESD Precautions.....	4-3
4-4 Operating Precautions	4-4

Chapter 5 Advanced Serverboard Setup

5-1 Handling the Serverboard	5-1
Precautions	5-1
Unpacking	5-2
5-2 Serverboard Installation	5-2
5-3 Connecting Cables.....	5-3
Connecting Data Cables	5-3
Connecting Power Cables	5-3
Connecting the Control Panel.....	5-3
5-4 I/O Ports	5-4
5-5 Installing the Processors and Heat Sinks	5-5
Memory Support.....	5-9
5-7 Adding PCI Add-On Cards.....	5-10
5-8 Serverboard Details	5-11
X7DWN+ Quick Reference	5-12
5-9 Connector Definitions	5-13
5-10 Jumper Settings	5-19

5-11	Onboard Indicators.....	5-23
5-12	Floppy, IDE, and SATA Ports	5-24
Chapter 6 Advanced Chassis Setup		
6-1	Static-Sensitive Devices.....	6-1
	Precautions	6-1
	Unpacking	6-1
6-2	Control Panel	6-2
6-3	System Fans	6-3
	System Fan Failure.....	6-3
	Replacing System Fans	6-3
6-4	Drive Bay Installation/Removal	6-4
	Accessing the Drive Bays	6-4
	SATA Drive Installation.....	6-5
	Hard Drive Backplane	6-6
	DVD-ROM and Floppy Drive Installation	6-7
6-5	Power Supply	6-8
	Power Supply Failure.....	6-8
	Removing/Replacing the Power Supply.....	6-8
Chapter 7 BIOS		
7-1	Introduction.....	7-1
7-2	Running Setup	7-2
7-3	Main BIOS Setup	7-2
	Main BIOS Setup Menu	7-3
	Main Setup Features.....	7-3
7-4	Advanced Setup.....	7-6
7-5	Security	7-25
7-6	Boot.....	7-26
7-7	Exit	7-27
Appendix A BIOS POST Messages		
Appendix B BIOS POST Codes		
Appendix C Intel HostRAID Setup Guidelines		
Appendix D Adaptec HostRAID Setup Guidelines		
Appendix E System Specifications		

Notes

Chapter 1

Introduction

1-1 Overview

The SuperServer 6025W-NTR+ is a high-end server that is comprised of two main subsystems: the SC825TQ-R700LP 2U server chassis and the X7DWN+ dual Intel® Xeon® processor serverboard. Please refer to our web site for information on operating systems that have been certified for use with the SuperServer 6025W-NTR+ (www.supermicro.com).

In addition to the serverboard and chassis, various hardware components have been included with the SuperServer 6025W-NTR+, as listed below:

- Three (3) 8-cm hot-swap chassis fans (FAN-0094L)
- One (1) air shroud (MCP-310-82502-0N)
- Two (2) CPU passive heatsinks (SNK-P0025P)
- One (1) DVD-ROM drive (DVM-PNSC-824)
- Two (2) 3.5" dummy drive trays
- One (1) DVD-ROM drive (DVM-PNSC-824B)
- One (1) front control panel cable (CBL-0087)
- One (1) rail set (MCP-290-00002-00)
- SATA Accessories
 - One (1) SATA backplane (BPN-SAS-825TQ)
 - One (1) 2-ft SATA cable (CBL-0044L)
 - Two (2) 35-mm SATA cables (CBL-0061L)
 - Two (2) 48-cm SATA cables (CBL-0178L)
 - One (1) 70-cm SATA cable (CBL-0179L)
 - Two (2) SATA SGPIO cables (CBL-0157L)
 - Eight (8) SATA hot-swap drive carriers (MCP-220-00001-01)(The chassis has eight carriers but only six SATA drives are supported.)

1-2 Serverboard Features

At the heart of the SuperServer 6025W-NTR+ lies the X7DWN+, a dual processor serverboard based on the Intel 5400 chipset and designed to provide maximum performance. Below are the main features of the X7DWN+. (See Figure 1-1 for a block diagram of the 5400 chipset).

Processors

The X7DWN+ supports single or dual LGA771 type Intel Xeon processors at a FSB speed of 1600/1333/1066 MHz. (Quad-Core Intel Xeon Processor 5400/5300LV or Dual-Core Intel Xeon Processor 5200/5100LV sequence, both CPUs must be of the same type.) Please refer to the serverboard description pages on our web site for a complete listing of supported processors (www.supermicro.com).

Memory

The X7DWN+ has sixteen 240-pin DIMM slots that can support up to 128 GB of FBD (Fully Buffered DIMM) ECC DDR2-800/667/533 SDRAM. Both 1.5V and 1.8V memory are supported. The memory operates in a 4-way interleaved configurations and requires requires modules of the same size and speed to be installed two at a time. See Chapter 5 for details.

Serial ATA

A SATA controller is integrated into the ESB2 (South Bridge) portion of the 5400 chipset to provide a six-port 3 Gb/s Serial ATA subsystem, which is RAID 0, 1, 10 and 5 supported. The Serial ATA drives are hot-swappable units.

Note: The operating system you use must have RAID support to enable the hot-swap capability and RAID function of the Serial ATA drives.

PCI Expansion Slots

The X7DWN+ has three PCI-Express x8 slots (two are Gen 2), one PCI-Express x4 slot (in a x8 slot), two 64-bit 133/100 MHz PCI-X slots and one UIO slot (see below).

UIO

The X7DWN+ is a specially-designed serverboard that features Supermicro's UIO (Universal I/O) technology. UIO serverboards have a PCI-Express x8 connector that can support any one of several types of UIO card types (low-profile only) to add SAS ports, additional LAN ports, etc. to the serverboard. This allows the user

to tailor the serverboard to their own needs. **Note:** the 6025W-NTR+ does not come with a UIO card pre-installed.

Onboard Controllers/Ports

One floppy drive connector and two onboard ATA/100 connectors (one reserved for the use of a compact flash card) are provided to support IDE hard drives or ATAPI devices. The color-coded I/O ports include one COM port (an additional COM header is located on the serverboard), a VGA (monitor) port, two USB 2.0 ports (three additional USB headers are included on the serverboard), PS/2 mouse and keyboard ports and two gigabit Ethernet ports.

ATI Graphics Controller

The X7DWN+ features an integrated ATI video controller based on the ES1000 32 MB graphics chip. The ES1000 was designed specifically for servers, featuring low power consumption, high reliability and superior longevity.

Other Features

Other onboard features that promote system health include onboard voltage monitors, a chassis intrusion header, auto-switching voltage regulators, chassis and CPU overheat sensors, virus protection and BIOS rescue.

1-3 Server Chassis Features

The following is a general outline of the main features of the SC825TQ-R700LP server chassis.

System Power

The SC825TQ-R700LP features a redundant 700W power supply composed of two separate power modules. This power redundancy feature allows you to replace a failed power supply without shutting down the system.

Serial ATA Subsystem

The SC825TQ-R700LP supports up to six 3 Gb/s Serial ATA drives. The Serial ATA drives are hot-swappable units and are connected to a backplane that provides power and control.

Note: The operating system you use must have RAID support to enable the hot-swap capability of the Serial ATA drives.

Front Control Panel

The control panel on the SuperServer 6025W-NTR+ provides you with system monitoring and control. LEDs indicate system power, HDD activity, network activity, system overheat and power supply failure. A main power button and a system reset button are also included. In addition, two USB ports have been incorporated into the control panel to provide front side USB access.

I/O Backplane

The SC825TQ-R700LP is an ATX form factor chassis designed to be used in a 2U rackmount configuration. The I/O backplane provides seven low-profile PCI expansion slots, one COM port, a parallel port, a VGA port, two USB 2.0 ports, PS/2 mouse and keyboard ports and two gigabit Ethernet ports.

Cooling System

The SC825TQ-R700LP chassis has an innovative cooling design that includes three 8-cm hot-plug system cooling fans located in the middle section of the chassis. An air shroud channels the airflow from the system fans to efficiently cool the processor area of the system. The power supply module also includes a cooling fan.

**Figure 1-1. Intel 5400/ESB2 Chipset:
System Block Diagram**

Note: This is a general block diagram. Please see Chapter 5 for details.

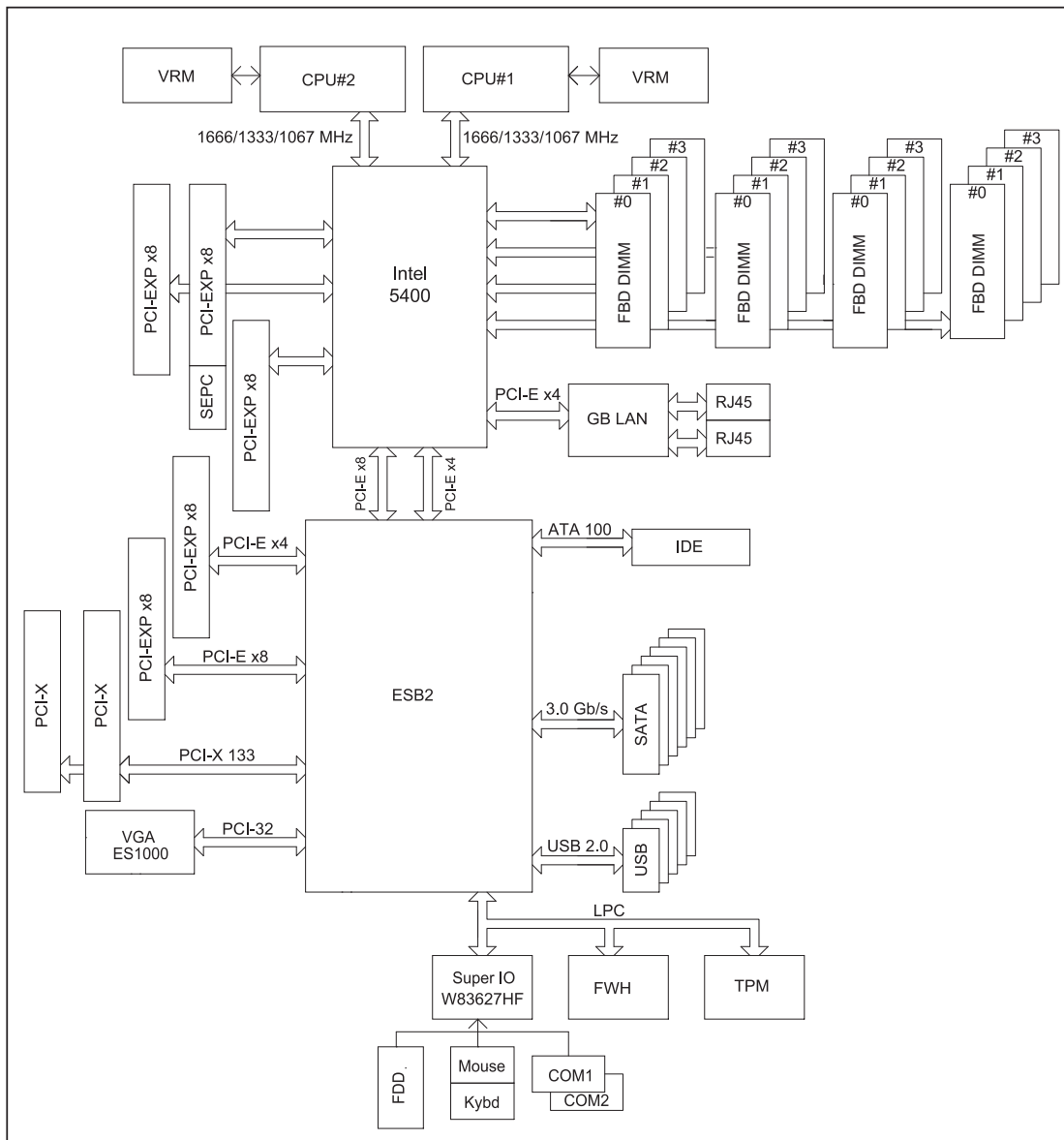

1-4 Contacting Supermicro

Headquarters

Address: Super Micro Computer, Inc.
980 Rock Ave.
San Jose, CA 95131 U.S.A.

Tel: +1 (408) 503-8000

Fax: +1 (408) 503-8008

Email: marketing@supermicro.com (General Information)
support@supermicro.com (Technical Support)

Web Site: www.supermicro.com

Europe

Address: Super Micro Computer B.V.
Het Sterrenbeeld 28, 5215 ML
's-Hertogenbosch, The Netherlands

Tel: +31 (0) 73-6400390

Fax: +31 (0) 73-6416525

Email: sales@supermicro.nl (General Information)
support@supermicro.nl (Technical Support)
rma@supermicro.nl (Customer Support)

Asia-Pacific

Address: Super Micro Computer, Inc.
4F, No. 232-1, Liancheng Rd.
Chung-Ho 235, Taipei County
Taiwan, R.O.C.

Tel: +886-(2) 8226-3990

Fax: +886-(2) 8226-3991

Web Site: www.supermicro.com.tw

Technical Support:

Email: support@supermicro.com.tw

Tel: 886-2-8228-1366, ext.132 or 139

Chapter 2

Server Installation

2-1 Overview

This chapter provides a quick setup checklist to get your SuperServer 6025W-NTR+ up and running. Following these steps in the order given should enable you to have the system operational within a minimum amount of time. This quick setup assumes that your system has come to you with the processors and memory preinstalled. If your system is not already fully integrated with a serverboard, processors, system memory etc., please turn to the chapter or section noted in each step for details on installing specific components.

2-2 Unpacking the System

You should inspect the box the SuperServer 6025W-NTR+ was shipped in and note if it was damaged in any way. If the server itself shows damage you should file a damage claim with the carrier who delivered it.

Decide on a suitable location for the rack unit that will hold the SuperServer 6025W-NTR+. It should be situated in a clean, dust-free area that is well ventilated. Avoid areas where heat, electrical noise and electromagnetic fields are generated. You will also need it placed near a grounded power outlet. Read the Rack and Server Precautions in the next section.

2-3 Preparing for Setup

The box the SuperServer 6025W-NTR+ was shipped in should include two sets of rail assemblies, two rail mounting brackets and the mounting screws you will need to install the system into the rack. Follow the steps in the order given to complete the installation process in a minimum amount of time. Please read this section in its entirety before you begin the installation procedure outlined in the sections that follow.

Choosing a Setup Location

- Leave enough clearance in front of the rack to enable you to open the front door completely (~25 inches) and approximately 30 inches of clearance in the back of the rack to allow for sufficient airflow and ease in servicing.

- This product is for installation only in a Restricted Access Location (dedicated equipment rooms, service closets and the like).
- This product is not suitable for use with visual display work place devices according to §2 of the the German Ordinance for Work with Visual Display Units.



Warnings and Precautions!



Rack Precautions

- Ensure that the leveling jacks on the bottom of the rack are fully extended to the floor with the full weight of the rack resting on them.
- In single rack installation, stabilizers should be attached to the rack. In multiple rack installations, the racks should be coupled together.
- Always make sure the rack is stable before extending a component from the rack.
- You should extend only one component at a time - extending two or more simultaneously may cause the rack to become unstable.

Server Precautions

- Review the electrical and general safety precautions in Chapter 4.
- Determine the placement of each component in the rack *before* you install the rails.
- Install the heaviest server components on the bottom of the rack first, and then work up.
- Use a regulating uninterruptible power supply (UPS) to protect the server from power surges, voltage spikes and to keep your system operating in case of a power failure.
- Allow the hot plug SATA drives and power supply modules to cool before touching them.
- Always keep the rack's front door and all panels and components on the servers closed when not servicing to maintain proper cooling.

Rack Mounting Considerations

Ambient Operating Temperature

If installed in a closed or multi-unit rack assembly, the ambient operating temperature of the rack environment may be greater than the ambient temperature of the room. Therefore, consideration should be given to installing the equipment in an environment compatible with the manufacturer's maximum rated ambient temperature (T_{mra}).

Reduced Airflow

Equipment should be mounted into a rack so that the amount of airflow required for safe operation is not compromised.

Mechanical Loading

Equipment should be mounted into a rack so that a hazardous condition does not arise due to uneven mechanical loading.

Circuit Overloading

Consideration should be given to the connection of the equipment to the power supply circuitry and the effect that any possible overloading of circuits might have on overcurrent protection and power supply wiring. Appropriate consideration of equipment nameplate ratings should be used when addressing this concern.

Reliable Ground

A reliable ground must be maintained at all times. To ensure this, the rack itself should be grounded. Particular attention should be given to power supply connections other than the direct connections to the branch circuit (i.e. the use of power strips, etc.).

2-4 Installing the System into a Rack

This section provides information on installing the SuperServer 6025W-NTR+ into a rack unit. If the 6025W-NTR+ has already been mounted into a rack, you can skip ahead to Sections 2-5 and 2-6. There are a variety of rack units on the market, which may mean the assembly procedure will differ slightly. The following is a guideline for installing the system into a rack with the rack rails provided. You should also refer to the installation instructions that came with the rack unit you are using.

Identifying the Sections of the Rack Rails

You should have received a total of six rack rail sections with the SuperServer 6025W-NTR+. Two of these sections secure directly to the 6025W-NTR+ and the third (which actually consists of two joined sections) secures directly to the rack itself. All screws and hardware mentioned in the installation steps should be included in the hardware kit.

Refer to Figure 2-1 to determine which rail section gets attached to the front of the chassis and which gets attached to the rear of the chassis. (The longer of the two is the front section. The third rail section attaches to the rack.)

Installing the Chassis Rails

Position the front and rear chassis rail sections along the side of the 6025W-NTR+ making sure the screw holes line up. Note that these two rails are left/right specific. Screw the front chassis rail (the long piece) securely to the side of the chassis (see Figure 2-1, step 1). There should be two screws for each side. Repeat this procedure for the other rail on the opposite side of the chassis. Then attach the two rear chassis rails to the chassis in the same manner, again keeping in mind that the rails are left/right specific. (You will also need to attach the rail brackets when installing into a telco rack.)

Locking Tabs: Both front chassis rails and the rack rails have a locking tab, which serves two functions. The first is to lock the server into place when installed and pushed fully into the rack, which is its normal position. Secondly, these tabs also lock the server in place when fully extended from the rack. This prevents the server from coming completely out of the rack when you pull it out for servicing.

Figure 2-1. Installing Chassis Rails

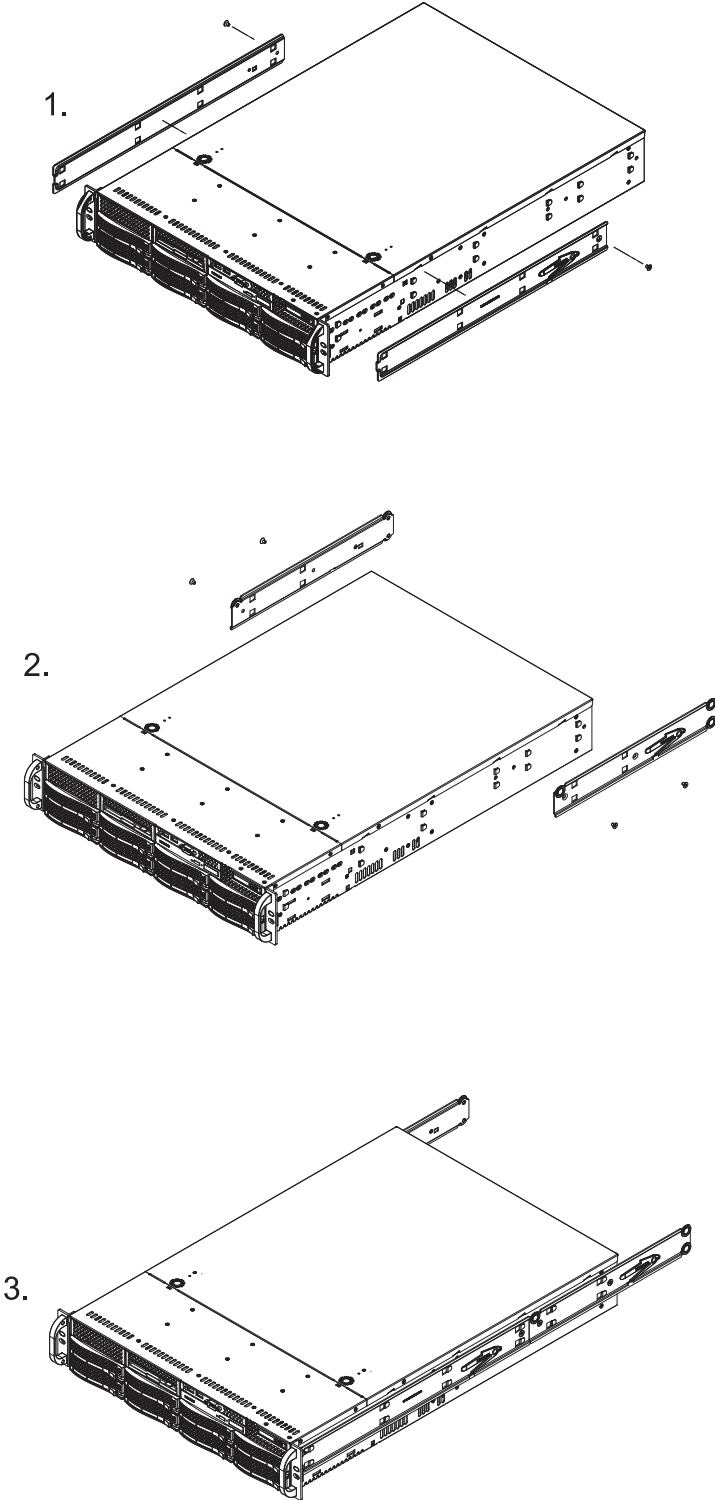

Installing the Rack Rails:

Determine where you want to place the SuperServer 6025W-NTR+ in the rack. (See Rack and Server Precautions in Section 2-3.) Position the fixed rack rail/sliding rail guide assemblies (made up of two inter-locking sections) at the desired location in the rack, keeping the sliding rail guide facing the inside of the rack and the rollers toward the front of the rack. Screw the assembly securely to the rack. Attach the other assembly to the other side of the rack, making sure both are at the exact same height and with the rail guides facing inward.

Installing the Server into the Rack

You should now have rails attached to both the chassis and the rack unit. The next step is to install the server into the rack. Do this by lining up the rear of the chassis rails with the front of the rack rails. Slide the chassis rails into the rack rails, keeping the pressure even on both sides (you may have to depress the locking tabs when inserting). See Figure 2-2.

When the server has been pushed completely into the rack, you should hear the locking tabs "click". Finish by inserting and tightening the thumbscrews that hold the front of the server to the rack.

Installing the Server into a Telco Rack

To install the SuperServer 6025W-NTR+ into a Telco type rack, use two L-shaped brackets on either side of the chassis (four total). First, determine how far the server will extend out the front of the rack. Larger chassis should be positioned to balance the weight between front and back. If a bezel is included on your server, remove it. Then attach the two front brackets to each side of the chassis, then the two rear brackets positioned with just enough space to accommodate the width of the rack. Finish by sliding the chassis into the rack and tightening the brackets to the rack.

Figure 2-2. Installing the Server into a Rack

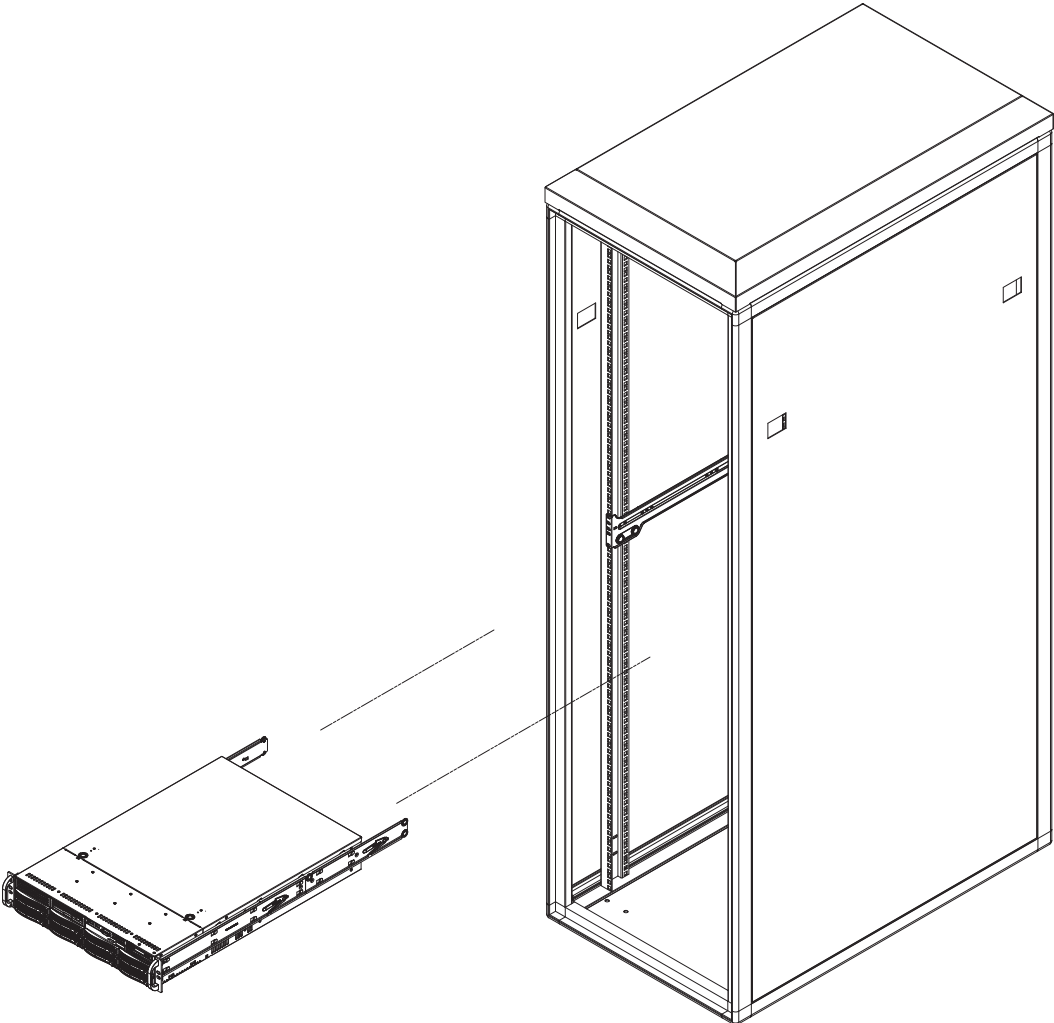

2-5 Checking the Serverboard Setup

After you install the 6025W-NTR+ in the rack, you will need to open the unit to make sure the serverboard is properly installed and all the connections have been made.

Accessing the inside of the System

1. First, grasp the two handles on either side and pull the unit straight out until it locks (you will hear a "click").
2. Next, depress the two buttons on the top of the chassis to release the top cover.
3. You can then lift the top cover from the chassis to gain full access to the inside of the server.

Checking the Components and Setup

1. You may have one or two processors already installed into the serverboard. Each processor needs its own heat sink. See Chapter 5 for instructions on processor and heat sink installation.
2. Your 6025W-NTR+ server system may have come with system memory already installed. Make sure all DIMMs are fully seated in their slots. For details on adding system memory, refer to Chapter 5.
3. If desired, you can install add-on cards to the system. See Chapter 5 for details on installing PCI add-on cards.
4. Make sure all power and data cables are properly connected and not blocking the chassis airflow. Also make sure that no cables are positioned in front of the fans. See Chapter 5 for details on cable connections.

Figure 2-3. Accessing the Inside of the System

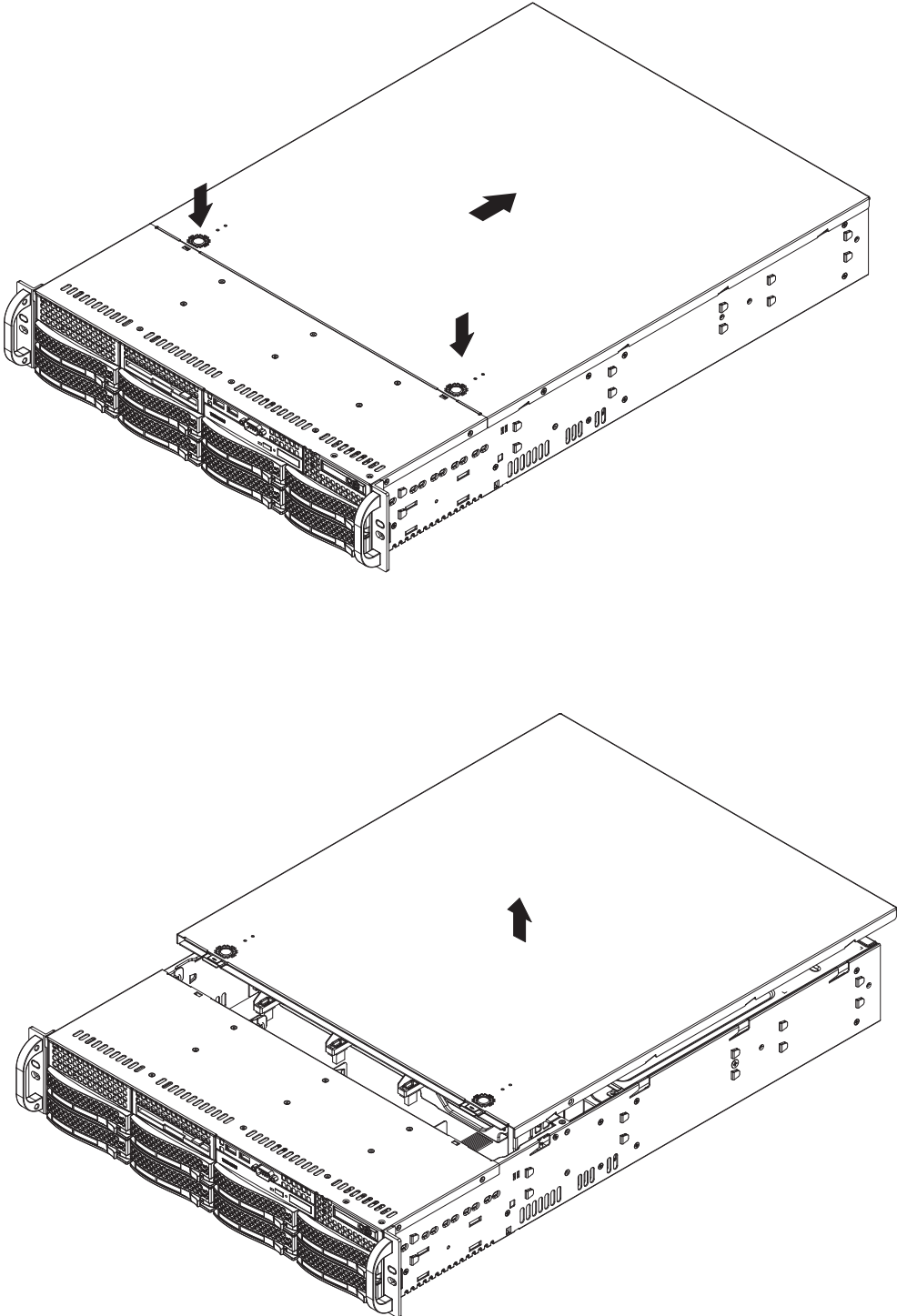

2-6 Checking the Drive Bay Setup

Next, you should check to make sure the peripheral drives and the Serial ATA drives have been properly installed and all connections have been made.

Checking the Drives

1. All drives are accessible from the front of the server. For servicing the DVD-ROM and floppy drives, you will need to remove the top chassis cover. The Serial ATA disk drives can be installed and removed from the front of the chassis without removing the top chassis cover.
2. A slim DVD-ROM and a floppy drive should be preinstalled in your server. Refer to Chapter 6 if you need to reinstall a DVD-ROM and/or floppy disk drive to the system.
3. Depending upon your system's configuration, your system may have one or more drives already installed. If you need to install SATA drives, please refer to Chapter 6.

Checking the Airflow

1. Airflow is provided by four 8-cm center chassis cooling fans. An air shroud is also included in the system to maximize airflow. The system component layout was carefully designed to direct sufficient cooling airflow to the components that generate the most heat.
2. Note that all power and data cables have been routed in such a way that they do not block the airflow generated by the fans.

Providing Power

1. Plug the power cord(s) from the power supply unit(s) into a high-quality power strip that offers protection from electrical noise and power surges. It is recommended that you use an uninterruptible power supply (UPS).
2. Depress the power on button on the front of the chassis.

Chapter 3

System Interface

3-1 Overview

There are several LEDs on the control panel as well as others on the Serial ATA drive carriers to keep you constantly informed of the overall status of the system as well as the activity and health of specific components. There are also two buttons on the chassis control panel.

3-2 Control Panel Buttons

The two push-buttons located on the front of the chassis are (in order from left to right) a reset button and a power on/off button.

RESET

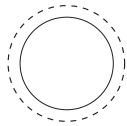

Reset

Use the reset button to reboot the system.



Power

This is the main power button, which is used to apply or turn off the main system power. Turning off system power with this button removes the main power but keeps standby power supplied to the system.

3-3 Control Panel LEDs

The control panel located on the front of the chassis has several LEDs. These LEDs provide you with critical information related to different parts of the system. This section explains what each LED indicates when illuminated and any corrective action you may need to take.



Power Fail

Indicates a power supply module has failed. The second power supply module will take the load and keep the system running but the failed module will need to be replaced. Refer to Chapter 6 for details on replacing the power supply. This LED should be off when the system is operating normally.



Overheat/Fan Fail:

When this LED flashes, it indicates a fan failure. When on continuously it indicates an overheat condition, which may be caused by cables obstructing the airflow in the system or the ambient room temperature being too warm. Check the routing of the cables and make sure all fans are present and operating normally. You should also check to make sure that the chassis covers are installed. Finally, verify that the heatsinks are installed properly (see Chapter 5). This LED will remain flashing or on as long as the indicated condition exists.



NIC1

Indicates network activity on the JLAN1 port when flashing.



NIC2

Indicates network activity on the JLAN2 port when flashing.



HDD

Indicates IDE channel activity. On the SuperServer 6025W-NTR+, this LED indicates SATA and/or DVD-ROM drive activity when flashing.



Power

Indicates power is being supplied to the system's power supply units. This LED should normally be illuminated when the system is operating.

3-4 Drive Carrier LEDs

SATA Drives

Each SATA drive carrier has two LEDs:

- **Green:** When illuminated, the green LED on the Serial ATA drive carrier indicates drive activity. A connection to the SATA backplane enables this LED to blink on and off when that particular drive is being accessed. Please refer to Chapter 6 for instructions on replacing failed SATA drives.
- **Red:** The red LED to indicate an SATA drive failure. If one of the SATA drives fails, you should be notified by your system management software. Please refer to Chapter 6 for instructions on replacing failed SATA drives.

Notes

Chapter 4

System Safety

4-1 Electrical Safety Precautions



Basic electrical safety precautions should be followed to protect yourself from harm and the SuperServer 6025W-NTR+ from damage:

- Be aware of the locations of the power on/off switch on the chassis as well as the room's emergency power-off switch, disconnection switch or electrical outlet. If an electrical accident occurs, you can then quickly remove power from the system.
- Do not work alone when working with high voltage components.
- Power should always be disconnected from the system when removing or installing main system components, such as the serverboard, memory modules and floppy drive. When disconnecting power, you should first power down the system with the operating system first and then unplug the power cords of all the power supply units in the system.
- When working around exposed electrical circuits, another person who is familiar with the power-off controls should be nearby to switch off the power if necessary.
- Use only one hand when working with powered-on electrical equipment. This is to avoid making a complete circuit, which will cause electrical shock. Use extreme caution when using metal tools, which can easily damage any electrical components or circuit boards they come into contact with.
- Do not use mats designed to decrease static electrical discharge as protection from electrical shock. Instead, use rubber mats that have been specifically designed as electrical insulators.
- The power supply power cords must include a grounding plug and must be plugged into grounded electrical outlets.

- Serverboard Battery: **CAUTION** - There is a danger of explosion if the onboard battery is installed upside down, which will reverse its polarities (see Figure 4-1). This battery must be replaced only with the same or an equivalent type recommended by the manufacturer. Dispose of used batteries according to the manufacturer's instructions.
- DVD-ROM Laser: **CAUTION** - this server may have come equipped with a DVD-ROM drive. To prevent direct exposure to the laser beam and hazardous radiation exposure, do not open the enclosure or use the unit in any unconventional way.
- Mainboard replaceable soldered-in fuses: Self-resetting PTC (Positive Temperature Coefficient) fuses on the mainboard must be replaced by trained service technicians only. The new fuse must be the same or equivalent as the one replaced. Contact technical support for details and support.

4-2 General Safety Precautions



Follow these rules to ensure general safety:

- Keep the area around the 6025W-NTR+ clean and free of clutter.
- The 6025W-NTR+ weighs approximately 57 lbs (25.9 kg.) when fully loaded. When lifting the system, two people at either end should lift slowly with their feet spread out to distribute the weight. Always keep your back straight and lift with your legs.
- Place the chassis top cover and any system components that have been removed away from the system or on a table so that they won't accidentally be stepped on.
- While working on the system, do not wear loose clothing such as neckties and unbuttoned shirt sleeves, which can come into contact with electrical circuits or be pulled into a cooling fan.
- Remove any jewelry or metal objects from your body, which are excellent metal conductors that can create short circuits and harm you if they come into contact with printed circuit boards or areas where power is present.

- After accessing the inside of the system, close the system back up and secure it to the rack unit with the retention screws after ensuring that all connections have been made.

4-3 ESD Precautions



Electrostatic discharge (ESD) is generated by two objects with different electrical charges coming into contact with each other. An electrical discharge is created to neutralize this difference, which can damage electronic components and printed circuit boards. The following measures are generally sufficient to neutralize this difference before contact is made to protect your equipment from ESD:

- Use a grounded wrist strap designed to prevent static discharge.
- Keep all components and printed circuit boards (PCBs) in their antistatic bags until ready for use.
- Touch a grounded metal object before removing the board from the antistatic bag.
- Do not let components or PCBs come into contact with your clothing, which may retain a charge even if you are wearing a wrist strap.
- Handle a board by its edges only; do not touch its components, peripheral chips, memory modules or contacts.
- When handling chips or modules, avoid touching their pins.
- Put the serverboard and peripherals back into their antistatic bags when not in use.
- For grounding purposes, make sure your computer chassis provides excellent conductivity between the power supply, the case, the mounting fasteners and the serverboard.

4-4 Operating Precautions



Care must be taken to assure that the chassis cover is in place when the 6025W-NTR+ is operating to assure proper cooling. Out of warranty damage to the system can occur if this practice is not strictly followed.

Figure 4-1. Installing the Onboard Battery

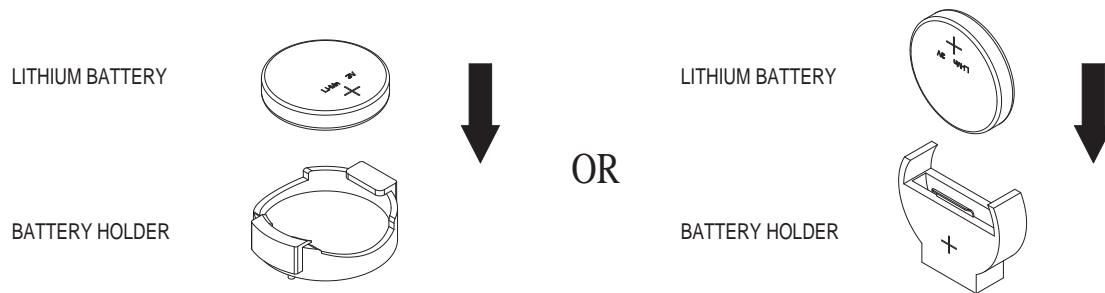

Chapter 5

Advanced Serverboard Setup

This chapter covers the steps required to install the X7DWN+ serverboard into the chassis, connect the data and power cables and install add-on cards. All serverboard jumpers and connections are also described. A layout and quick reference chart are included in this chapter for your reference. Remember to completely close the chassis when you have finished working with the serverboard to better cool and protect the system.

5-1 Handling the Serverboard

Electrostatic discharge (ESD) can damage electronic components. To prevent damage to any printed circuit boards (PCBs), it is important to handle them very carefully (see previous chapter). To prevent the serverboard from bending, keep one hand under the center of the board to support it when handling. The following measures are generally sufficient to protect your equipment from electric static discharge.

Precautions

- Use a grounded wrist strap designed to prevent Electrostatic Discharge (ESD).
- Touch a grounded metal object before removing any board from its antistatic bag.
- Handle a board by its edges only; do not touch its components, peripheral chips, memory modules or gold contacts.
- When handling chips or modules, avoid touching their pins.
- Put the serverboard, add-on cards and peripherals back into their antistatic bags when not in use.
- For grounding purposes, make sure your computer chassis provides excellent conductivity between the power supply, the case, the mounting fasteners and the serverboard.

Unpacking

The serverboard is shipped in antistatic packaging to avoid electrical static discharge. When unpacking the board, make sure the person handling it is static protected.

5-2 Serverboard Installation

This section explains the first step of physically mounting the X7DWN+ into the SC825TQ-R700LP chassis. Following the steps in the order given will eliminate the most common problems encountered in such an installation. To remove the serverboard, follow the procedure in reverse order.

Installing to the Chassis

1. Access the inside of the system by removing the screws from the back lip of the top cover of the chassis, then pull the cover off.
2. The X7DWN+ requires a chassis big enough to support a 13.68" x 13.05" serverboard, such as Supermicro's SC825TQ-R700LP.
3. Make sure that the I/O ports on the serverboard align properly with their respective holes in the I/O shield at the back of the chassis.
4. Carefully mount the serverboard to the serverboard tray by aligning the board holes with the raised metal standoffs that are visible in the chassis.
5. Insert screws into all the mounting holes on your serverboard that line up with the standoffs and tighten until snug (if you screw them in too tight, you might strip the threads). Metal screws provide an electrical contact to the serverboard ground to provide a continuous ground for the system.
6. Finish by replacing the top cover of the chassis.

5-3 Connecting Cables

Now that the serverboard is installed, the next step is to connect the cables to the board. These include the data cables for the peripherals and control panel and the power cables.

Connecting Data Cables

The cables used to transfer data from the peripheral devices have been carefully routed to prevent them from blocking the flow of cooling air that moves through the system from front to back. If you need to disconnect any of these cables, you should take care to keep them routed as they were originally after reconnecting them (make sure the red wires connect to the pin 1 locations). The following data cables (with their locations noted) should be connected. (See the layout on page 5-10 for connector locations.)

- SATA drive data cables (I-SATA0 ~ I-SATA5)
- Control Panel cable (JF1)
- DVD-ROM drive cable (IDE#1)
- USB cable (USB2/3)
- COM Port cable (COM2)

Important! Make sure the the cables do not come into contact with the fans.

Connecting Power Cables

The X7DWN+ has a 24-pin primary power supply connector (JPW1) for connection to the ATX power supply. In addition, there is a 4-pin secondary power connector (JPW2) as well as an 8-pin processor power connector (JPW3) that must be connected to your power supply. See Section 5-9 for power connector pin definitions.

Connecting the Control Panel

JF1 contains header pins for various front control panel connectors. See Figure 5-1 for the pin locations of the various front control panel buttons and LED indicators.

All JF1 wires have been bundled into a single cable to simplify this connection. Make sure the red wire plugs into pin 1 as marked on the board. The other end connects to the Control Panel PCB board, located just behind the system status LEDs on the chassis. See Chapter 5 for details and pin descriptions.

Figure 5-1. Control Panel Header Pins

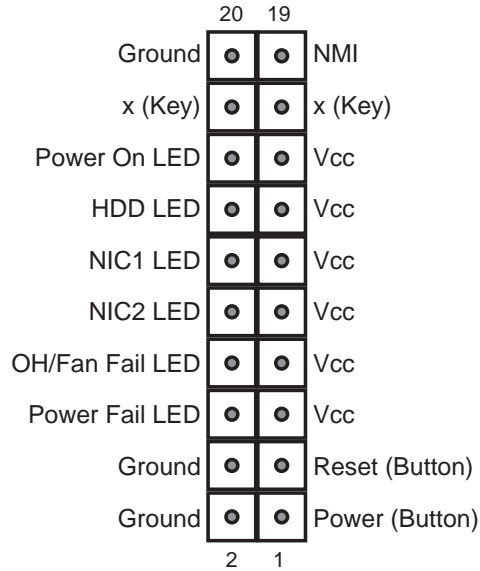

5-4 I/O Ports

The I/O ports are color coded in conformance with the PC 99 specification. See Figure 5-2 below for the colors and locations of the various I/O ports.

Figure 5-2. I/O Ports

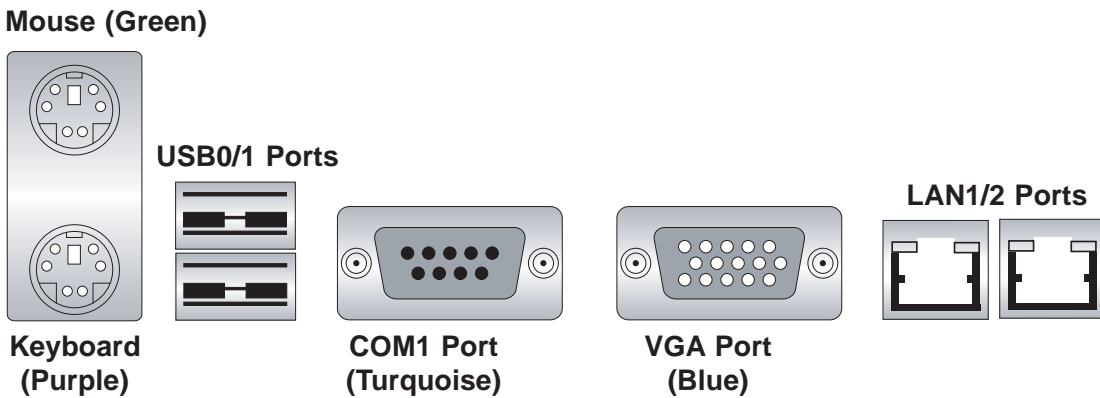

5-5 Installing the Processors and Heat Sinks



Avoid placing direct pressure to the top of the processor package. Always remove the power cord first before adding, removing or changing any hardware components.

Notes: Always connect the power cord last and remove it before adding, removing or changing any components. Make sure to install the processor into the CPU socket before you install the CPU heat sink.

Intel's boxed Xeon CPU package contains the CPU fan and heat sink assembly. If you buy the CPUs separately, use only Intel-certified heat sinks and fans.

Make sure to install the heat sink backplate and the serverboard into the chassis before you install the CPU heat sink and fan (see below).

Inspect the Xeon 5400/5200 CPU socket and make sure that the CPU plastic cap is in place and none of the socket pins are bent. Otherwise, contact the retailer immediately.

All graphics shown in this manual are for reference only. The components that came with your serverboard may or may not look exactly the same as the pictures shown in this manual.

Installation Procedure

For proper system setup, please follow the procedure below:

1. Install the heat sink backplate into the chassis if needed
2. Install the serverboard into the chassis.
3. Install the CPU(s).
4. Install the heat sink or/and cooling fans (if any).
5. Connect fan and power cables.

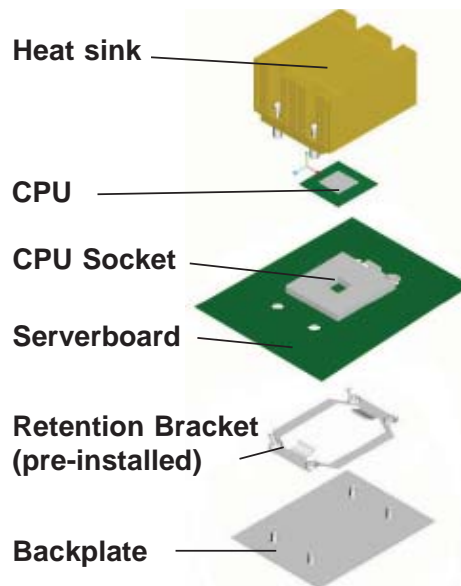

CPU Installation

1. A black PnP cap is attached to the load plate to protect the CPU socket. Press the load lever down and away from the retention clasp to release the load plate from its locked position.

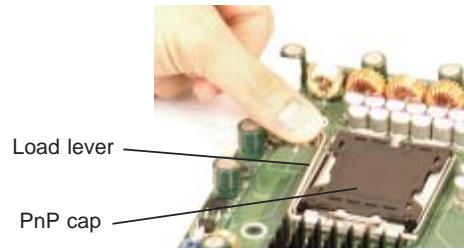

2. Gently lift the load lever to open the load plate.
3. Use your thumb and your index finger to hold the CPU at opposite sides.



4. Align pin1 of the CPU (the corner marked with a triangle) with the notched corner of the CPU socket.

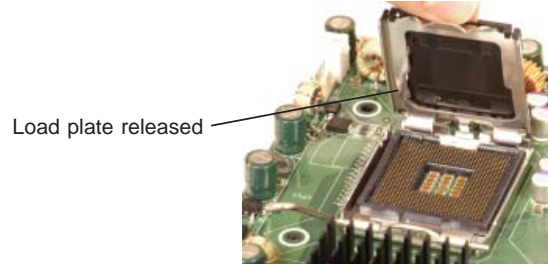

5. Find the corner of the CPU that has a semi-circle cutout below a gold dot (CPU key). This corner should be aligned with the cutout on the socket (socket key).

6. Once aligned, carefully lower the CPU straight down into the socket. Do not drop the CPU on the socket, do not move the CPU horizontally or vertically and do not rub the CPU against any surface or any of the contacts, which may damage the CPU and/or contacts.



Warning! Make sure you lift the lever completely when installing the CPU; otherwise, damage to the socket or CPU may occur.

7. With the CPU in the socket, inspect the four corners of the CPU to make sure that it is properly installed.
8. Use your thumb to gently push the load lever down until it snaps into the retention clasp.
9. If the CPU is properly installed into the socket, the PnP cap will be automatically released from the load plate when the lever locks. Remove the cap. Repeat steps to install a second CPU if desired.

Warning! Keep the plastic PnP cap. The serverboard must be shipped with the PnP cap properly installed to protect the CPU socket. Shipment without the PnP cap properly installed will void the warranty.

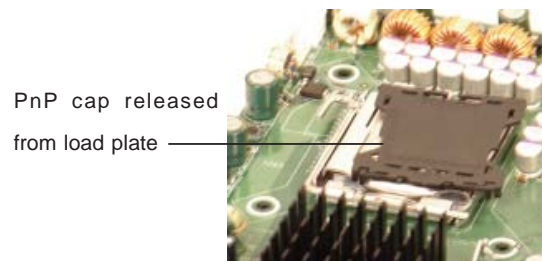
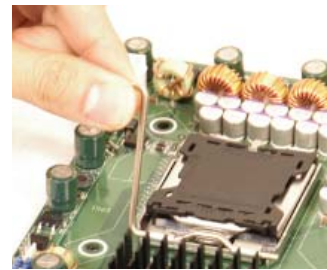
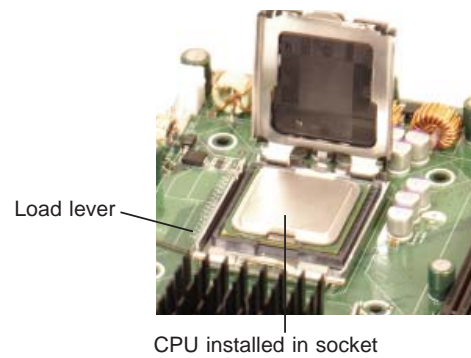
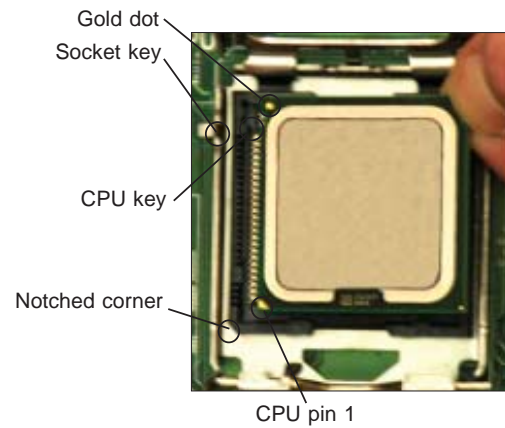

Installation and Removal of the Heat Sink

CPU Heat Sink Installation

1. Do not apply any thermal grease to the heat sink or the CPU die; the required amount has already been applied.
2. Place the heatsink on top of the CPU so that the four mounting holes are aligned with those on the retention mechanism.
3. Screw in two diagonal screws (i.e. the #1 and the #2 screws) until just snug (do not over-tighten the screws, which may damage the CPU.)
4. Finish the installation by fully tightening all four screws.

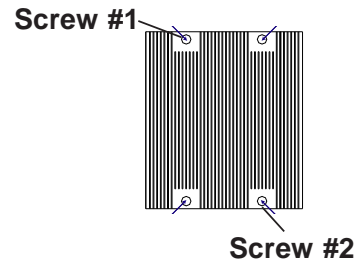

Uninstalling the Heat Sink



Warning: We do not recommend removing the CPU or the heat sink. However, if you do need to uninstall the heat sink, please follow these instructions to avoid damaging the CPU or the CPU socket.

1. Unscrew and remove the heat sink screws in the sequence shown in the picture on the right.
2. Hold the heat sink as shown in the picture on the right and gently wriggle to loosen it from the CPU. (Do not use excessive force when doing this!)
3. Once the heat sink is loosened, remove it from the CPU socket.
4. Clean the surface of the CPU and the heat sink to get rid of the old thermal grease. Reapply the proper amount of thermal grease before you re-install the heat sink.

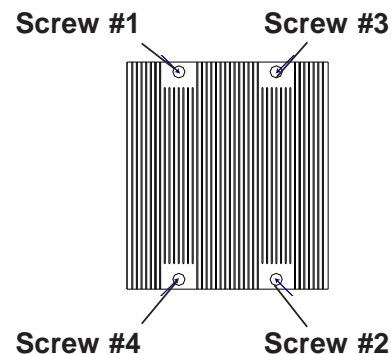

5-6 Installing Memory



CAUTION! Exercise extreme care when installing or removing DIMM modules to prevent any possible damage.

Memory Support

The X7DWN+ supports up to 128 GB fully buffered (FBD) ECC DDR2 800/667/533 in 16 DIMM slots (four channels, two branches)*. Both 1.5V and 1.8V memory are supported. Single channel memory, two-way interleaved memory and four-way interleaved memory schemes are all supported. Using four-way interleaved memory will result in the best performance. Please use memory modules of the same type, speed, timing and same on a serverboard. See the following table for memory installation.

Installing Memory Modules

1. Insert the desired number of Fully Buffered DDR2 modules into the memory slots, starting with DIMM #1A. To enhance memory performance, install pairs of memory modules of the same type and of the same, beginning with DIMM #1A and DIMM #2A, then DIMM #3A and DIMM #4A, etc. (see Memory Configuration Table below).
2. Insert each DIMM module vertically into its slot. Pay attention to the notch along the bottom of the module to avoid installing incorrectly (see Figure 5-3).
3. Gently press down on the DIMM module until it snaps into place in the slot. Repeat for all modules.

*Note: DDR2-800 DIMMs are only fully supported when using 1600 MHz FSB CPUs. With 1333 and 1066 FSB CPUs, DDR2-800 DIMMs will run at 667 MHz.

Memory Configuration Chart																
Number of DIMMs	Branch 0								Branch 1							
	Bank 1 (Channel 0)				Bank 2 (Channel 1)				Bank 3 (Channel 2)				Bank 4 (Channel 3)			
2 DIMMs	1A	---	---	---	2A	---	---	---	---	---	---	---	---	---	---	---
4 DIMMs	1A	---	---	---	2A	---	---	---	3A	---	---	---	4A	---	---	---
8 DIMMs	1A	1B	---	---	2A	2B	---	---	3A	3B	---	---	4A	4B	---	---
12 DIMMs	1A	1B	1C	---	2A	2B	2C	---	3A	3B	3C	---	4A	4B	4C	---
16 DIMMs	1A	1B	1C	1D	2A	2B	2C	2D	3A	3B	3C	3D	4A	4B	4C	4D

Notes: i. DIMM slot# specified = DIMM slot to be populated; “---” = DIMM slot not to be populated. ii. Both FBD 533 MHz, 667MHz and 800MHz DIMMs are supported, however, you need to use the memory modules of the same speed and type. iii. Interleaved memory is supported when pairs of DIMM modules are installed. For optimal memory performance, please install pairs of memory modules *in both Branch 0 and Branch 1*.

Figure 5-3. DIMM Installation

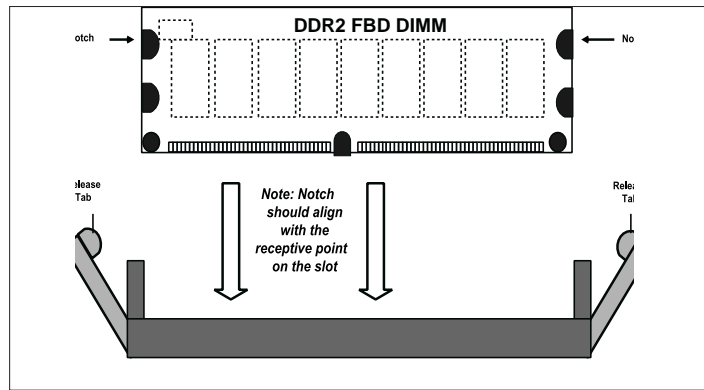

Top View of DDR2 Slot

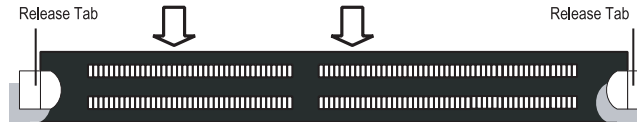

To Install: Insert module vertically and press down until it snaps into place. Pay attention to the bottom notches.

To Remove: Use your thumbs to gently push each release tab outward to free the DIMM from the slot.

5-7 Adding PCI Add-On Cards

The 6025W-NTR+ can accommodate three PCI-Express x8 Gen.2 cards, one PCI-Express x4 card (in a x8 slot), two PCI-X 133/100 MHz cards and one UIO card. All cards must be low-profile.

Installing an Add-on Card

1. Begin by removing the shield for the PCI slot you wish to populate.
2. Fully seat the card into the slot, pushing down with your thumbs evenly on both sides of the card.
3. Finish by using a screw to secure the top of the card shield to the chassis. The PCI slot shields protect the serverboard and its components from EMI and aid in proper ventilation, so make sure there is always a shield covering each unused slot.

5-8 Serverboard Details

Figure 5-4. X7DWN+ Layout
(not drawn to scale)

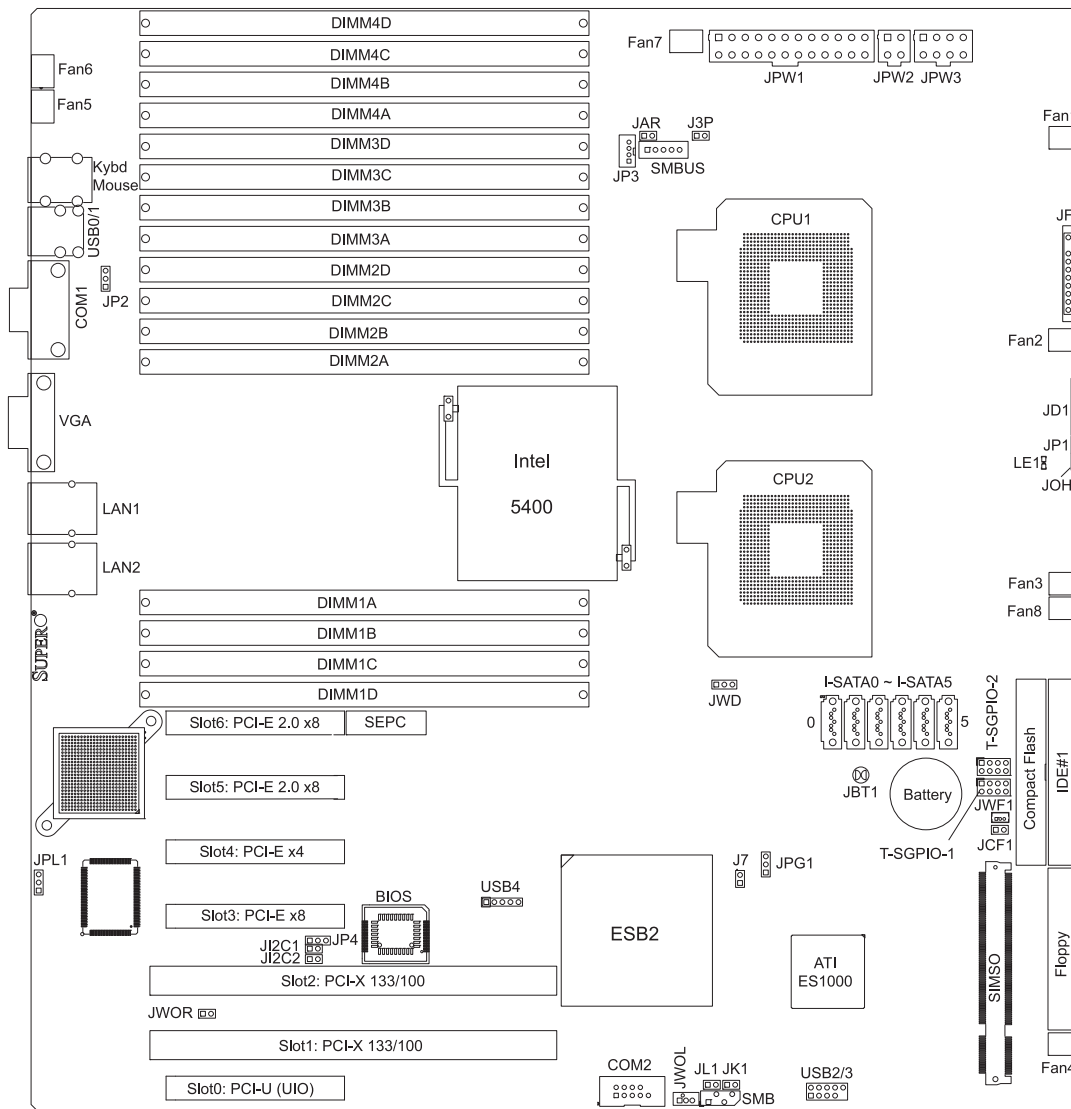

X7DWN+ Quick Reference

Jumper	Description	Default Setting
J3P	3rd Power Fail Detect	Open (Disabled)
JBT1	CMOS Clear	(See Section 5-10)
JCF1	Compact Flash Card Master/Slave	Closed (Master)
JI ² C1/JI ² C2	I ² C to PCI-X/PCI-E Slots	Open (Disabled)
JP1	Reboot Option	Open (Reboot)
JP2	Memory Voltage Select	Pins 1-2 (Auto)
JPG1	VGA Enable/Disable	Pins 1-2 (Enabled)
JPL1	LAN1/2 Enable/Disable	Pins 1-2 (Enabled)
JWD	Watch Dog	Pins 1-2 (Reset)

Connector	Description
COM1/COM2	COM1/COM2 Serial Port/Header
FAN 1-8	Chassis/CPU Fan Headers
Floppy	Floppy Disk Drive Connector
IDE1/IDE2	IDE Drive/Compact Flash Card Connector
I-SATA0 ~ I-SATA5	SATA Ports
J3P	PWR Supply Fail LED
JAR	Alarm Rest Header
JD1	Onboard Speaker/Power LED
JF1	Front Panel Connector
JK1	Keylock Header
JL1	Chassis Intrusion Header
JOH1	Overheat Warning Header
JPW1	24-pin ATX Power Connector
JPW2/JPW3	+12V 4-Pin / +12V 8-pin Power Connectors
JWOL/JWOR	Wake-On-LAN Header/Wake-On-Ring Header
JPW2/JPW3	+12V 4-Pin / +12V 8-pin Power Connectors
JWF1	Compact Flash Card Power Connector
LAN1/2	Gigabit Ethernet (RJ45) Ports
SIMSO	SIMSO (Remote Management) Slot
SMB	System Management Bus Header
SMBUS	SMBus I ² C Connector
T-SGPIO-1/T-SGPIO-2	Serial General Purpose Input/Output Headers
USB0/1, USB2/3/4	Universal Serial Bus (USB) Ports, Headers

5-9 Connector Definitions

Main ATX Power Supply Connector

The primary power supply connector (JPW1) meets the SSI (Superset ATX) 24-pin specification. Refer to the table on the right for the pin definitions of the ATX 24-pin power connector. You must also connect the 8-pin (JPW2/JPW3) processor power connectors to your power supply (see below).

ATX Power 24-pin Connector Pin Definitions (JPW1)			
Pin#	Definition	Pin #	Definition
13	+3.3V	1	+3.3V
14	-12V	2	+3.3V
15	COM	3	COM
16	PS_ON	4	+5V
17	COM	5	COM
18	COM	6	+5V
19	COM	7	COM
20	Res (NC)	8	PWR_OK
21	+5V	9	5VSB
22	+5V	10	+12V
23	+5V	11	+12V
24	COM	12	+3.3V

Secondary Power Connector

JPW2 must also be connected to the power supply. See the table on the right for pin definitions.

+12V 4-pin Power Pin Definitions (JPW2)	
Pins	Definition
1 - 2	Ground
3 - 4	+12V

Required Connection

Secondary Power Connector

JPW3 must also be connected to the power supply. See the table on the right for pin definitions.

+12V 8-pin Power Pin Definitions (JPW3)	
Pins	Definition
1 - 4	Ground
5 - 8	+12V

Required Connection

PW_ON Connector

The PW_ON connector is on pins 1 and 2 of JF1. This header should be connected to the chassis power button. See the table on the right for pin definitions.

Power Button Pin Definitions (JF1)	
Pin#	Definition
1	PW_ON
2	Ground

Reset Connector

The reset connector is located on pins 3 and 4 of JF1 and attaches to the reset switch on the computer chassis. See the table on the right for pin definitions.

Reset Button Pin Definitions (JF1)	
Pin#	Definition
3	Reset
4	Ground

Power Fail LED

The Power Fail LED connection is located on pins 5 and 6 of JF1. Refer to the table on the right for pin definitions.

PWR Fail LED Pin Definitions (JF1)	
Pin#	Definition
5	Vcc
6	Ground

Overheat/Fan Fail LED (OH)

Connect an LED to the OH connection on pins 7 and 8 of JF1 to provide advanced warning of chassis overheating. Refer to the table on the right for pin definitions.

OH/Fan Fail LED Pin Definitions (JF1)		OH/Fan Fail Indicator Status	
Pin#	Definition	State	Definition
7	Vcc	Off	Normal
8	Ground	On	Overheat
		Flash- ing	Fan Fail

NIC2 (JLAN2) LED

The LED connections for JLAN2 are on pins 9 and 10 of JF1. Attach an LED cable to display network activity. See the table on the right for pin definitions.

NIC2 LED Pin Definitions (JF1)	
Pin#	Definition
9	Vcc
10	Ground

NIC1 (JLAN1) LED

The LED connections for JLAN1 are on pins 11 and 12 of JF1. Attach an LED cable to display network activity. See the table on the right for pin definitions.

NIC1 LED Pin Definitions (JF1)	
Pin#	Definition
11	Vcc
12	Ground

HDD LED

The HDD LED connection is located on pins 13 and 14 of JF1. This LED is used to display all IDE and SATA activity. See the table on the right for pin definitions.

HDD LED Pin Definitions (JF1)	
Pin#	Definition
13	Vcc
14	HD Active

Power On LED

The Power On LED connector is located on pins 15 and 16 of JF1 (use JLED for a 3-pin connector). This connection is used to provide LED indication of power being supplied to the system. See the table on the right for pin definitions.

Power LED Pin Definitions (JF1)	
Pin#	Definition
15	5V Stby
16	Control

NMI Button

The non-maskable interrupt button header is located on pins 19 and 20 of JF1. Refer to the table on the right for pin definitions.

NMI Button Pin Definitions (JF1)	
Pin#	Definition
19	Control
20	Ground

Fan Headers

There are eight fan headers on the serverboard, all of which are 4-pin fans. However, pins 1-3 of the fan headers are backward compatible with the traditional 3-pin fans. See the table on the right for pin definitions. The onboard fan speeds are controlled by Thermal Management (via Hardware Monitoring) under the Advanced Section in the BIOS. The default is disabled. When using Thermal Management setting, please use all 3-pin fans or all 4-pin fans.

Fan Header Pin Definitions (FAN1-8)	
Pin#	Definition
1	Ground (Black)
2	+12V (Red)
3	Tachometer
4	PWM Control

Note: Fan 7 is for the CPU1 and Fan8 is for the CPU2 heat sink.

ATX PS/2 Keyboard and PS/2 Mouse Ports

The ATX PS/2 keyboard and the PS/2 mouse are located beside the USB0/1 ports. The mouse port is above the keyboard port. See the table on the right for pin definitions.

PS/2 Keyboard and Mouse Port Pin Definitions (J28)	
Pin#	Definition
1	Data
2	NC
3	Ground
4	VCC
5	Clock
6	NC

Chassis Intrusion

The Chassis Intrusion header is designated JL1. Attach an appropriate cable from the chassis to inform you of a chassis intrusion when the chassis is opened

Chassis Intrusion Pin Definitions (JL1)	
Pin#	Definition
1	Intrusion Input
2	Ground

Wake-On-LAN

The Wake-On-LAN header is designated JWOL on the serverboard. See the table on the right for pin definitions. You must also have a LAN card with a Wake-On-LAN connector and cable to use this feature.

Wake-On-LAN Pin Definitions (JWOL)	
Pin#	Definition
1	+5V Standby
2	Ground
3	Wake-up

Wake-On-Ring

The Wake-On-Ring header is designated JWOR. This function allows your computer to receive and be "awakened" by an incoming call when in the suspend state. See the table on the right for pin definitions. You must also have a WOR card and cable to use this feature.

Wake-On-Ring Pin Definitions (JWOR)	
Pin#	Definition
1	Ground (Black)
2	Wake-up

Power Supply Fail LED

Connect a cable from your power supply to JP3 to provide warning of power supply failure. This warning signal is passed through the PWR_LED pin to indicate of a power failure on the chassis. See the table on the right for pin definitions.

PWR Supply Fail LED Pin Definitions (JP3)	
Pin#	Definition
1	PWR 1: Fail
2	PWR 2: Fail
3	PWR 3: Fail
4	Signal: Alarm Reset

Note: This feature is only available when using Supermicro redundant power supplies.

LAN1/2 (Ethernet Ports)

Two Ethernet ports (designated LAN1 and LAN2) are located beside the VGA port on the I/O backplane. These ports accept RJ45 type cables.



Serial Ports

Two serial ports are included on the serverboard. COM1 is a backpanel port and COM2 is a header located near the JWOL header. See the table on the right for pin definitions.

Serial Port Pin Definitions (COM1/COM2)			
Pin #	Definition	Pin #	Definition
1	DCD	6	DSR
2	RXD	7	RTS
3	TXD	8	CTS
4	DTR	9	RI
5	Ground	10	NC

Power LED/Speaker

On JD1 header, pins 1-3 are for a power LED and pins 4-7 are for the speaker. Close pins 4-7 with a jumper to use an external speaker. If you wish to use the onboard speaker, please close pins 6-7. See the table on the right for speaker pin definitions.

Power LED/Speaker Connector (JD1)	
Pin Setting	Definition
Pins 6-7	Internal Speaker
Pins 4-7	External Speaker

Universal Serial Bus (USB)

There are two Universal Serial Bus ports located on the I/O panel and three additional USB headers located on the serverboard. The headers can be used to provide front side USB access (cables not included). See the table on the right for pin definitions.

Universal Serial Bus Pin Definitions (USB)			
USB0/1		USB2/3/4	
Pin #	Definition	Pin #	Definition
1	+5V	1	+5V
2	PO-	2	PO-
3	PO+	3	PO+
4	Ground	4	Ground
5	N/A	5	Key

SGPIO Headers

The SGPIO (Serial General Purpose Input/Output) headers are used to communicate with a system-monitoring chip on the backplane. See the table on the right for pin definitions.

SGPIO Header Pin Definitions (T-SGPIO-1/T-SGPIO-2)			
Pin#	Definition	Pin	Definition
1	*NC	2	*NC
3	Ground	4	DATA Out
5	Load	6	Ground
7	Clock	8	*NC

NC = No Connection

Alarm Reset

If three power supplies are installed, the system can notify you when any of the three power modules fail. Connect JAR to a micro-switch to enable you to turn off the alarm that is activated when a power module fails. See the table on the right for pin definitions.

Alarm Reset Header Pin Definitions (JAR)	
Pin Setting	Definition
Pin 1	Ground
Pin 2	+5V

Power SMB (I²C) Connector

The power SMB (I²C) connector, called SMBUS, monitors the status of the power supply, fan and system temperature. See the table on the right for pin definitions.

PWR SMB Header Pin Definitions (SMBUS)	
Pin#	Definition
1	Clock
2	Data
3	PWR Fail (Input from PS to MB)
4	Ground
5	+3.3V

SMB

A System Management Bus header is located at SMB. Connect the appropriate cable here to utilize SMB on your system.

SMB Header Pin Definitions (SMB)	
Pin#	Definition
1	Data
2	Ground
3	Clock
4	No Connection

Overheat LED/Fan Fail (JOH1)

The JOH1 header is used to connect an LED to provide warning of chassis overheating. This LED will blink to indicate a fan failure. Refer to the table on right for pin definitions.

OH/Fan Fail LED States		Overheat LED Pin Definitions (JOH1)	
State	Message	Pin#	Definition
Solid	Overheat	1	5vDC
Blinking	Fan Fail	2	OH Active

Keylock

The keyboard lock connection is designated JK1. Utilizing this header allows you to inhibit any actions made on the keyboard, effectively "locking" it.

Keylock Pin Definitions (JK1)	
Pin#	Definition
1	Ground
2	Keylock R-N

Compact Flash Card PWR Connector

A Compact Flash Card Power Connector is located at JWF1. For the Compact Flash Card to work properly, you will need to enable with JCF1 and connect a Compact Flash Card power cable to JWF1 first.

Compact Flash Card PWR Connector (JWF1)	
Jumper	Definition
On	Compact Flash Power On
Off	Compact Flash Power Off

5-10 Jumper Settings

Explanation of Jumpers

To modify the operation of the serverboard, jumpers can be used to choose between optional settings. Jumpers create shorts between two pins to change the function of the connector. Pin 1 is identified with a square solder pad on the printed circuit board. See the serverboard layout pages for jumper locations.

Note: On a two-pin jumper, "Closed" means the jumper is on both pins and "Open" means the jumper is either on only one pin or completely removed.

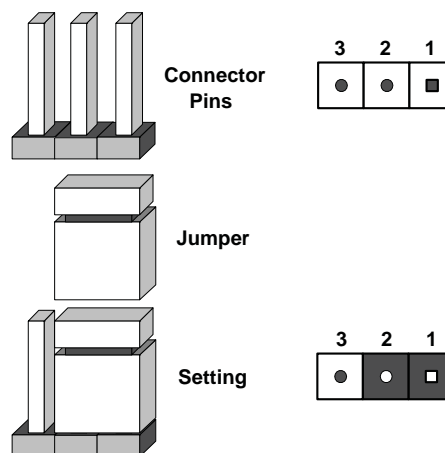

CMOS Clear

JBT1 is used to clear CMOS (which will also clear any passwords). Instead of pins, this jumper consists of contact pads to prevent accidentally clearing the contents of CMOS.

To clear CMOS,

1. First power down the system and unplug the power cord(s).
2. With the power disconnected, short the CMOS pads with a metal object such as a small screwdriver.
3. Remove the screwdriver (or shorting device).
4. Reconnect the power cord(s) and power on the system.

Note: Do not use the PW ON connector to clear CMOS.

VGA Enable/Disable

JPG1 allows you to enable or disable the VGA port. The default position is on pins 1 and 2 to enable VGA. See the table on the right for jumper settings.

VGA Enable/Disable Jumper Settings (JPG1)	
Jumper Setting	Definition
Pins 1-2	Enabled
Pins 2-3	Disabled

LAN1/2 Enable/Disable

Change the setting of jumper JPL1 to enable or disable the LAN1/LAN2 Ethernet port on the serverboard. See the table on the right for jumper settings. The default setting is enabled.

LAN1/2 Enable/Disable Jumper Settings (JPL1)	
Jumper Setting	Definition
Pins 1-2	Enabled
Pins 2-3	Disabled

3rd Power Fail Detect

The system can notify you in the event of a power supply failure. This feature is available when three power supply units are installed in the chassis with one acting as a backup. If you only have one or two power supply units installed, you should disable this detection feature (the default setting) with J3P to prevent false alarms.

3rd Power Fail Detect Jumper Settings (J3P)	
Jumper Setting	Definition
Closed	Enabled
Open	Disabled

Watch Dog Enable/Disable

JWD controls the Watch Dog function. Watch Dog is a system monitor that can reboot the system when a software application hangs. Jumping pins 1-2 will cause WD to reset the system if an application hangs. Jumping pins 2-3 will generate a non-maskable interrupt signal for the application that hangs. See the table on the right for jumper settings. Watch Dog must also be enabled in BIOS.

Note: When enabled, the user needs to write their own application software in order to disable the Watch Dog Timer.

Watch Dog Jumper Settings (JWD)	
Jumper Setting	Definition
Pins 1-2	Reset
Pins 2-3	NMI
Open	Disabled

Compact Flash Master/Slave Select

A Compact Flash Master (Primary)/Slave (Secondary) Select Jumper is located at JCF1. Close this jumper to enable Compact Flash Card. For the Compact Flash Card or the Compact Flash Jumper (JCF1) to work properly, you will need to connect the Compact Flash Card power cable to JWF1 first. Refer to the board layout below for the location.

Compact Flash Card Master/Slave Select (JCF1)	
Jumper	Definition
Open	Slave (Secondary)
Closed	Master (Primary)

I²C Bus to PCI-X/PCI-Exp. Slots

Jumpers JI²C1 and JI²C2 allow you to connect the System Management Bus (I²C) to the PCI-X/PCI-E slots. The default setting is Open (Disabled.) Both jumpers must be set to the same setting See the table on the right for jumper settings.

I ² C to PCI-X/PCI-E Slots Jumper Settings (JI ² C1/JI ² C2)		
Jumper Setting	Definition	
JI ² C1: Closed	JI ² C2: Closed	Enabled
JI ² C1: Open	JI ² C2: Open	Disabled

Reboot Option

Setting jumper JP1 to Open (the default setting) will allow the system to automatically reboot after power-off. See the table on the right for jumper settings.

Reboot Option Jumper Settings (JP1)	
Setting	Definition
Off	Reboot
On	No Reboot

Memory Voltage Select

Jumper JP2 allows the user to select the memory voltage for the motherboard. The default setting is Auto. See the table on the right for jumper settings.

Memory Voltage Select Jumper Settings (JP2)	
Setting	Definition
Pins 1-2	Auto
Pins 2-3	1.5V
Open	1.8V

5-11 Onboard Indicators

LAN1/2 LEDs

The Ethernet ports (located beside the VGA port) have two LEDs. On each port, one LED indicates activity while the other LED may be green, amber or off to indicate the speed of the connection. See the table on the right for the functions associated with the connection speed LED.

GLAN1/2 LED (Connection Speed Indicator)	
LED Color	Definition
Off	10 MHz
Green	100 MHz
Amber	1 GHz

Onboard Power LED (LE1)

An Onboard Power LED is located at LE1. This LED Indicator is lit when the system is on. Be sure to unplug the power cable before removing or adding any components. See the table on the right for more details.

Onboard PWR LED Indicator (LE1)	
LED Color	Definition
Off	System Off (PWR cable not connected)
Green	System On
Green: Flashing Quickly	ACPI S1 State
Green: Flashing Slowly	ACPI S3 (STR) State

5-12 Floppy, IDE, and SATA Ports

Use the following information to connect the IDE hard disk drive cables.

- A red mark on a wire typically designates the location of pin 1.
- The 80-wire ATA100/66 IDE hard disk drive cable that came with your system has two connectors to support two drives. This special cable should be used to take advantage of the speed this new technology offers. The blue connector connects to the onboard IDE connector interface and the other connector(s) to your hard drive(s). Consult the documentation that came with your disk drive for details on actual jumper locations and settings for the hard disk drive.

Floppy Drive Connector

The floppy connector is located at J17. See the table below for pin definitions.

Floppy Drive Connector Pin Definitions (J17)			
Pin#	Definition	Pin #	Definition
1	Ground	2	FDHDIN
3	Ground	4	Reserved
5	Key	6	FDEDIN
7	Ground	8	Index
9	Ground	10	Motor Enable
11	Ground	12	Drive Select B
13	Ground	14	Drive Select B
15	Ground	16	Motor Enable
17	Ground	18	DIR
19	Ground	20	STEP
21	Ground	22	Write Data
23	Ground	24	Write Gate
25	Ground	26	Track 00
27	Ground	28	Write Protect
29	Ground	30	Read Data
31	Ground	32	Side 1 Select
33	Ground	34	Diskette

IDE Connectors

There are two IDE connectors (one blue and one white) on the serverboard. IDE#1 (blue) is designated as the Primary IDE drive. The white connector is designated as the Secondary IDE drive and is reserved for Compact Flash Card use only. (See the note below.) See the table on the right for pin definitions.

Note: The white slot is reserved for Compact Flash Cards only. Do not use it for other devices. If populated with a Compact Flash Card, IDE#1 (the blue slot) will be available for one device only. For the Compact Flash Card to work properly, you will need to connect a power cable to JWF1 first.

IDE Drive Connector Pin Definitions (IDE#1)			
Pin#	Definition	Pin #	Definition
1	Reset IDE	2	Ground
3	Host Data 7	4	Host Data 8
5	Host Data 6	6	Host Data 9
7	Host Data 5	8	Host Data 10
9	Host Data 4	10	Host Data 11
11	Host Data 3	12	Host Data 12
13	Host Data 2	14	Host Data 13
15	Host Data 1	16	Host Data 14
17	Host Data 0	18	Host Data 15
19	Ground	20	Key
21	DRQ3	22	Ground
23	I/O Write	24	Ground
25	I/O Read	26	Ground
27	IOCHRDY	28	BALE
29	DACK3	30	Ground
31	IRQ14	32	IOCS16
33	Addr1	34	Ground
35	Addr0	36	Addr2
37	Chip Select 0	38	Chip Select 1
39	Activity	40	Ground

SATA Ports

There are no jumpers to configure the onboard SATA connectors. See the table on the right for pin definitions.

SATA Port Pin Definitions (I-SATA0~I-SATA5)	
Pin #	Definition
1	Ground
2	TXP
3	TXN
4	Ground
5	RXN
6	RXP
7	Ground

Notes

Chapter 6

Advanced Chassis Setup

This chapter covers the steps required to install components and perform maintenance on the SC825TQ-R700LP chassis. For component installation, follow the steps in the order given to eliminate the most common problems encountered. If some steps are unnecessary, skip ahead to the step that follows.

Tools Required: The only tool you will need to install components and perform maintenance is a Philips screwdriver.

6-1 Static-Sensitive Devices

Electrostatic discharge (ESD) can damage electronic components. To prevent damage to any printed circuit boards (PCBs), it is important to handle them very carefully. The following measures are generally sufficient to protect your equipment from ESD damage.

Precautions

- Use a grounded wrist strap designed to prevent static discharge.
- Touch a grounded metal object before removing any board from its antistatic bag.
- Handle a board by its edges only; do not touch its components, peripheral chips, memory modules or gold contacts.
- When handling chips or modules, avoid touching their pins.
- Put the motherboard, add-on cards and peripherals back into their antistatic bags when not in use.
- For grounding purposes, make sure your computer chassis provides excellent conductivity between the power supply, the case, the mounting fasteners and the serverboard.

Unpacking

The serverboard is shipped in antistatic packaging to avoid static damage. When unpacking the board, make sure the person handling it is static protected.

Figure 6-1. Front and Rear Chassis Views

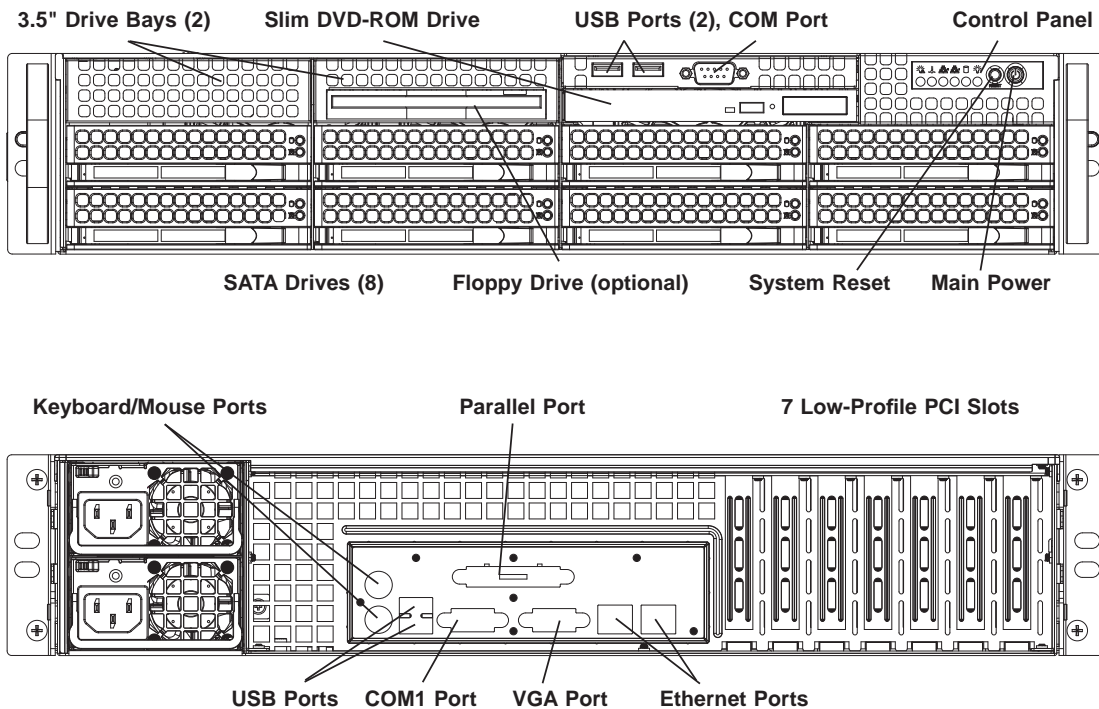

6-2 Control Panel

The control panel (located on the front of the chassis) must be connected to the JF1 connector on the serverboard to provide you with system status indications. A ribbon cable has bundled these wires together to simplify the connection. Connect the cable from JF1 on the serverboard to JP4 on the Control Panel PCB (printed circuit board). Make sure the red wire plugs into pin 1 on both JF1 and JP4. Pull all excess cabling out of the airflow path. The LEDs inform you of system status. See Chapter 3 for details on the LEDs and the control panel buttons. Details on JF1 can be found in Chapter 5.

6-3 System Fans

Three 8-cm hot-swap fans provide the cooling for the SuperServer 6025W-NTR+. It is very important that the chassis top cover is properly installed and making a good seal in order for the cooling air to circulate properly through the chassis and cool the components. See Figure 6-2.

System Fan Failure

Fan speed is controlled by system temperature via a BIOS setting. If a fan fails, the remaining fans will ramp up to full speed and the overheat/fan fail LED on the control panel will turn on. Replace any failed fan at your earliest convenience with the same type and model (the system can continue to run with a failed fan). Remove the top chassis cover while the system is still running to determine which of the fans has failed.

Replacing System Fans

Removing a fan

1. Remove the chassis cover.
2. Press the tabs on the sides of the fan to unlock and remove the fan and its housing. The fan's power connections will automatically detach.
3. System power does not need to be shut down since the fans are hot-pluggable.

Installing a new fan

1. Replace the failed fan with an identical 8-cm, 12 volt fan (available from Supermicro, p/n FAN-0070).
2. Position the new fan into the space vacated by the failed fan previously removed. A "click" can be heard when the fan is fully installed in place and the power connections are made.
3. If the system power is on, the hot-plug feature will cause the fan to start immediately upon being connected to its header on the serverboard.

Figure 6-2. Removing System Cooling Fans

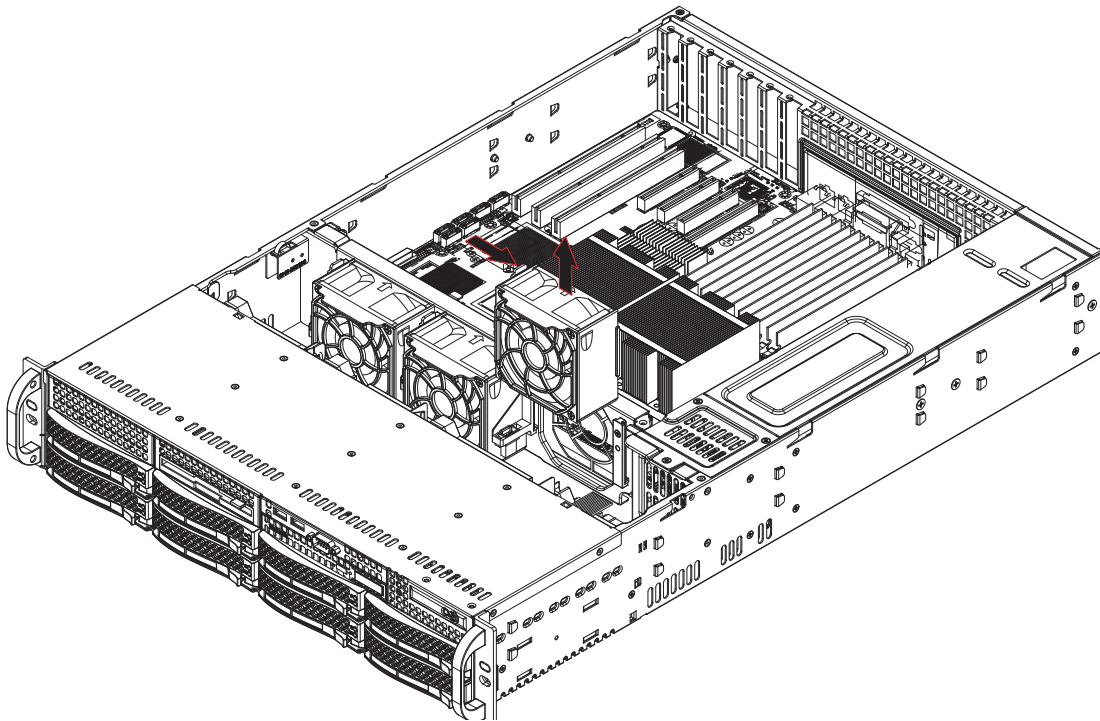

6-4 Drive Bay Installation/Removal

Accessing the Drive Bays

SATA Drives: You do not need to access the inside of the chassis or remove power to replace or swap SATA drives. Proceed to the next step for instructions.

Note: You must use standard 1" high, SATA drives in the SuperServer 6025W-NTR+.

DVD-ROM/Floppy Disk Drive: For installing/removing the DVD-ROM or floppy disk drive, you will need to gain access to the inside of the server by removing the top cover of the chassis. Proceed to the "DVD-ROM and Floppy Drive Installation" section later in this chapter for instructions.

5.25" Drive Bay: For installing/removing a component in the 5.25" drive bay, proceed to the "5.25" Drive Bay Installation" section later in this chapter for instructions.

SATA Drive Installation

The SATA drives are mounted in drive carriers to simplify their installation and removal from the chassis. These carriers also help promote proper airflow for the drives. For this reason, even empty carriers without SATA drives installed must remain in the chassis.

Mounting a SATA drive in a drive carrier

1. To add a new SATA drive, install a drive into the carrier with the printed circuit board side facing down so that the mounting holes align with those in the carrier.
2. Secure the drive to the carrier with four screws, as shown in Figure 6-3.

Installing/removing hot-swap Serial ATA drives

1. Push the release button located beside the drive's LEDs.
2. Swing the handle fully out and use it to pull the drive carrier straight out (see Figure 6-4). **Note:** Your OS must have RAID support to enable the hot-plug capability of the SATA drives.

Figure 6-3. Mounting a SATA Drive in a Carrier

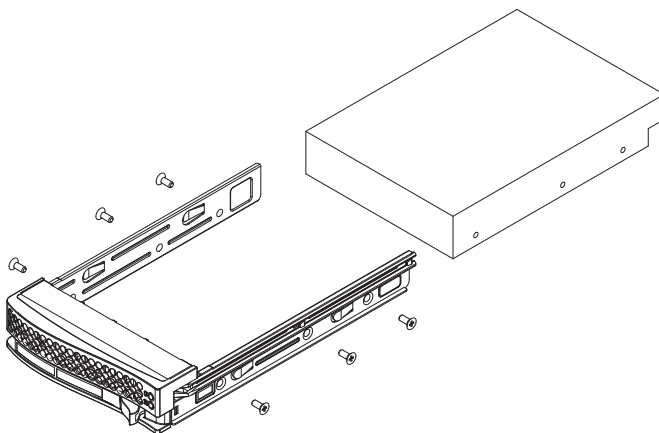

Use caution when working around the SATA backplane. Do not touch the backplane with any metal objects and make sure no ribbon cables touch the backplane or obstruct the holes, which aid in proper airflow.



Important: Regardless of how many SATA hard drives are installed, all drive carriers must remain in the drive bays to maintain proper airflow.

Figure 6-4. Removing a Serial ATA Drive Carrier

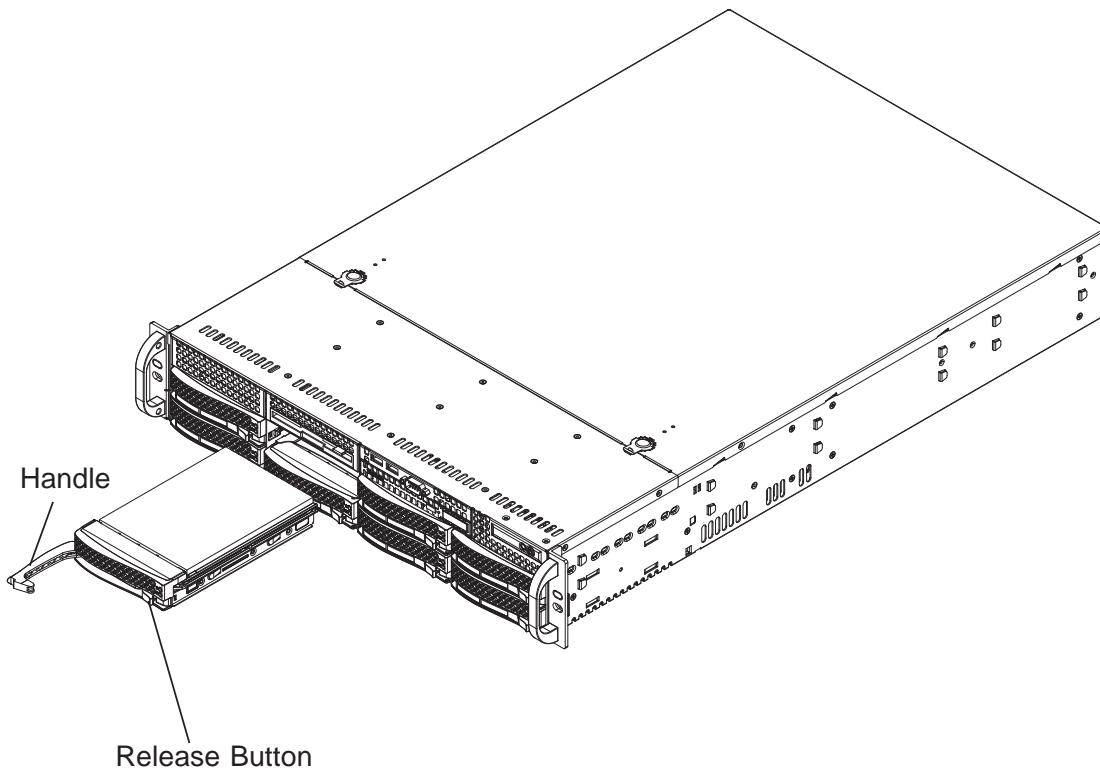

Important: All of the SATA drive carriers must remain in the drive bays to maintain proper cooling airflow.

Hard Drive Backplane

The SATA drives plug into a backplane that provides power, drive ID and bus termination. A RAID controller can be used with the backplane to provide data security. The operating system you use must have RAID support to enable the hot-swap capability of the Serial ATA drives. The backplane is already preconfigured, so there are no jumpers or switches present on it.

DVD-ROM and Floppy Drive Installation

The top cover of the chassis must be opened to gain full access to the DVD-ROM and floppy drive bays. The 6025W-NTR+ accommodates only slim type DVD-ROM drives. Side mounting brackets are typically needed to mount a slim DVD-ROM drive in the 6025W-NTR+ server.

Accessing the inside of the chassis

1. Release the retention screws that secure the server unit to the rack.
2. Grasp the two handles on either side and pull the unit straight out until it locks (you will hear a "click").
3. Next, depress the two buttons on the top of the chassis to release the top cover and at the same time, push the cover away from you until it stops. You can then lift the top cover from the chassis to gain full access to the inside of the server. **Note:** You must power down the system before installing or removing floppy or IDE components.

Drives mount on rails and should "click" into place to be correctly and fully installed in their bays.

- The floppy disk drive cable has seven twisted wires.
- A color mark on a cable typically designates the location of pin 1.
- A single floppy disk drive ribbon cable has 34 wires and two connectors to provide for two floppy disk drives. The connector with twisted wires always connects to drive A, and the connector that does not have twisted wires always connects to drive B.

6-5 Power Supply

The SuperServer 6025W-NTR+ has a 700 watt redundant power supply consisting of two power modules. Each power supply module has an auto-switching capability, which enables it to automatically sense and operate at a 100V - 240V input voltage.

Power Supply Failure

If either of the two power supply modules fail, the other module will take the full load and allow the system to continue operation without interruption. The PWR Fail LED will illuminate and remain on until the failed unit has been replaced. Replacement units can be ordered directly from Supermicro (see contact information in the Preface). The power supply units have a hot-swap capability, meaning you can replace the failed unit without powering down the system.

Removing/Replacing the Power Supply

You do not need to shut down the system to replace a power supply unit. The backup power supply module will keep the system up and running while you replace the failed hot-swap unit. Replace with the same model (see part number in the Appendix), which can be ordered directly from Supermicro.

Removing the power supply

1. First unplug the power cord from the failed power supply module.
2. Depress the locking tab on the power supply module.
3. Use the handle to pull it straight out with the rounded handle.

Installing a new power supply

1. Replace the failed hot-swap unit with another identical power supply unit.
2. Push the new power supply unit into the power bay until you hear a click.
3. Secure the locking tab on the unit.
4. Finish by plugging the AC power cord back into the unit.

Chapter 7

BIOS

7-1 Introduction

This chapter describes the Phoenix BIOS™ Setup utility for the X7DWN+. The Phoenix ROM BIOS is stored in a flash chip and can be easily upgraded using a floppy disk-based program.

Note: Due to periodic changes to the BIOS, some settings may have been added or deleted and might not yet be recorded in this manual. Please refer to the Manual Download area of the Supermicro web site <<http://www.supermicro.com>> for any changes to the BIOS that may not be reflected in this manual.

System BIOS

The BIOS is the Basic Input Output System used in all IBM® PC, XT™, AT®, and PS/2® compatible computers. The Phoenix BIOS stores the system parameters, types of disk drives, video displays, etc. in the CMOS. The CMOS memory requires very little electrical power. When the computer is turned off, a backup battery provides power to the CMOS Logic, enabling it to retain system parameters. When the computer is powered on, the computer is configured with the values stored in the CMOS Logic by the system BIOS, which gains control at boot up.

How To Change the Configuration Data

The CMOS information that determines the system parameters may be changed by entering the BIOS Setup utility. This Setup utility can be accessed by pressing the <Delete> key at the appropriate time during system boot.

Starting the Setup Utility

Normally, the only visible POST (Power On Self Test) routine is the memory test. As the memory is being tested, press the <Delete> key to enter the main menu of the BIOS Setup utility. From the main menu, you can access the other setup screens, such as the Security and Power menus. Beginning with Section 7-3, detailed descriptions are given for each parameter setting in the Setup utility.

Warning: Do not shut down or reset the system while updating BIOS to prevent possible boot failure.



7-2 Running Setup

Default settings are in bold text unless otherwise noted.

The BIOS setup options described in this section are selected by choosing the appropriate text from the main BIOS Setup screen. All displayed text is described in this section, although the screen display is often all you need to understand how to set the options as shown on the following page.

When you first power on the computer, the Phoenix BIOS™ is immediately activated.

While the BIOS is in control, the Setup program can be activated in one of two ways:

1. By pressing <Delete> immediately after turning the system on, or
2. When the message shown below appears briefly at the bottom of the screen during the POST (Power On Self-Test), press the <Delete> key to activate the main Setup menu:

Press the <Delete> key to enter Setup

7-3 Main BIOS Setup

All main Setup options are described in this section. The main BIOS Setup screen is displayed below.

Use the Up/Down arrow keys to move among the different settings in each menu. Use the Left/Right arrow keys to change the options for each setting.

Press the <Esc> key to exit the CMOS Setup Menu. The next section describes in detail how to navigate through the menus.

Items that use submenus are indicated with the ► icon. With the item highlighted, press the <Enter> key to access the submenu.

Main BIOS Setup Menu

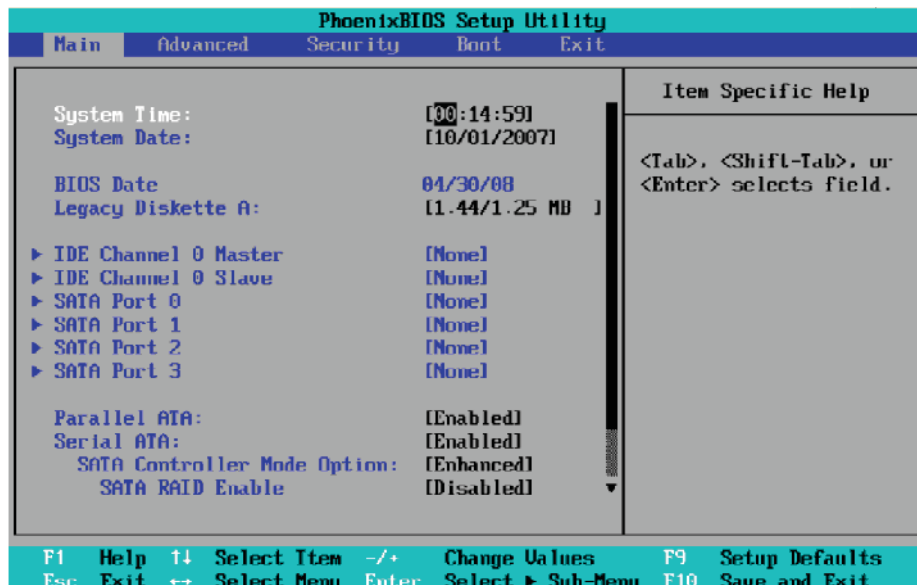

Main Setup Features

System Time

To set the system date and time, key in the correct information in the appropriate fields. Then press the <Enter> key to save the data.

System Date

Using the arrow keys, highlight the month, day and year fields, and enter the correct data. Press the <Enter> key to save the data.

BIOS Date

This field displays the date when this version of BIOS was built.

Legacy Diskette A

This setting allows the user to set the type of floppy disk drive installed as diskette A. The options are Disabled, 360Kb 5.25 in, 1.2MB 5.25 in, 720Kb 3.5 in, **1.44/1.25MB**, 3.5 in and 2.88MB 3.5 in.

► IDE Channel 0 Master/Slave, SATA Port 0, SATA Port 1, SATA Port 2 and SATA Port 3

These settings allow the user to set the parameters of IDE Channel 0 Master/Slave, SATA Port 0, SATA Port 1, SATA Port 2, SATA Port 3 slots. Hit <Enter> to activate the following sub-menu screen for detailed options of these items. Set the correct configurations accordingly. The items included in the sub-menu are:

Type

This option allows the user to select the type of IDE hard drive. Select **Auto** to allow the BIOS to automatically configure the parameters of the HDD installed at the connection. Enter a number between 1 to 39 to select a predetermined HDD type. Select User to allow the user to enter the parameters of the HDD installed. Select CDROM if a CDROM drive is installed. Select ATAPI if a removable disk drive is installed.

Multi-Sector Transfers

This item allows the user to specify the number of sectors per block to be used in multi-sector transfer. The options are **Disabled**, 4 Sectors, 8 Sectors, and 16 Sectors.

LBA Mode Control

This item determines whether the Phoenix BIOS will access the IDE Channel 0 Master Device via the LBA mode. The options are Enabled and **Disabled**.

32 Bit I/O

This option allows the user to enable or disable the function of 32-bit data transfer. The options are Enabled and **Disabled**.

Transfer Mode

This option allows the user to set the transfer mode. The options are **Standard**, Fast PIO1, Fast PIO2, Fast PIO3, Fast PIO4, FPIO3/DMA1 and FPIO4/DMA2.

Ultra DMA Mode

This option allows the user to select Ultra DMA Mode. The options are **Disabled**, Mode 0, Mode 1, Mode 2, Mode 3, Mode 4, and Mode 5.

Parallel ATA

This setting allows the user to enable or disable the function of Parallel ATA. The options are Disabled, **Channel 0**, Channel 1, and Both.

Serial ATA

This setting allows the user to enable or disable the function of Serial ATA. The options are Disabled and **Enabled**.

SATA Controller Mode Option

Select Compatible to allow the SATA and PATA drives to be automatically-detected and be placed in the Legacy Mode by the BIOS. Select **Enhanced** to allow the SATA and PATA drives to be to be automatically-detected and be placed in the Native IDE Mode. (**Note:** The Enhanced mode is supported by the Windows 2000 OS or a later version.)

When the SATA Controller Mode is set to "**Enhanced**", the following items will display:

Serial ATA (SATA) RAID Enable

Select Enable to enable Serial ATA RAID Functions. (For the Windows OS environment, use the RAID driver if this feature is set to Enabled. When this item is set to Enabled, the item: "ICH RAID Code Base" will be available for you to select either Intel or Adaptec Host RAID firmware to be activated. If this item is set to **Disabled**, the item-SATA AHCI Enable will be available.) The options are Enabled and **Disabled**.

ICH RAID Code Base

Select Intel to enable Intel's SATA RAID firmware. Select Adaptec to use Adaptec's HostRAID firmware. The options are **Intel** and Adaptec.

SATA AHCI Enable

Select Enable to enable the function of Serial ATA Advanced Host Interface. (Take caution when using this function. This feature is for advanced programmers only. The options are Enabled and **Disabled**.)

System Memory

This display informs you how much system memory is recognized as being present in the system.

Extended Memory

This display informs you how much extended memory is recognized as being present in the system.

7-4 Advanced Setup

Choose Advanced from the Phoenix BIOS Setup Utility main menu with the arrow keys. You should see the following display. The items with a triangle beside them have sub menus that can be accessed by highlighting the item and pressing <Enter>.

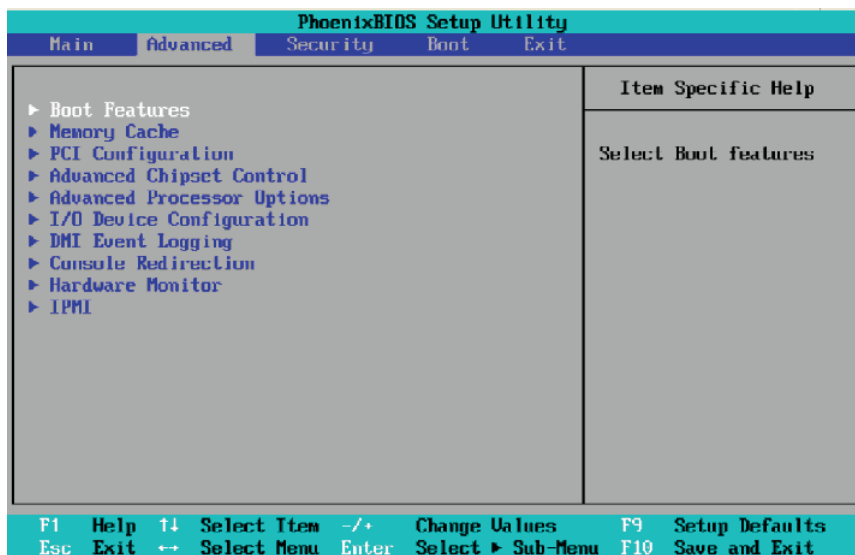

► Boot Features

Access the submenu to make changes to the following settings.

QuickBoot Mode

If enabled, this feature will speed up the POST (Power On Self Test) routine by skipping certain tests after the computer is turned on. The settings are **Enabled** and Disabled. If Disabled, the POST routine will run at normal speed.

QuietBoot Mode

This setting allows you to **Enable** or Disable the graphic logo screen during boot-up.

POST Errors

Select Enable to stop the POST routine and allow the system to display error messages when an error occurs during bootup. The options are **Enabled** and Disabled.

ACPI Mode

Use the setting to determine if you want to employ ACPI (Advanced Configuration and Power Interface) power management on your system. The options are **Yes** and No.

Power Button Behavior

If set to **Instant-Off**, the system will power off immediately as soon as the user hits the power button. If set to 4-sec., the system will power off when the user presses the power button for 4 seconds or longer. The options are **instant-off** and 4-sec override.

Resume On Modem Ring

Select On to “wake your system up” when an incoming call is received by your modem. The options are On and **Off**.

EFI OS Boot

If enabled, this feature provides support for EFI OS booting. The options are Enabled and **Disabled**.

OS Booting

Set this feature to Enabled to allow the OS to boot up the system. The options are Enabled and **Disabled**.

Power Loss Control

This setting allows you to choose how the system will react when power returns after an unexpected loss of power. The options are Stay Off, Power On, and **Last State**.

Watch Dog

If enabled, this option will automatically reset the system if the system is not active for more than a predefined time period. The options are Enabled and **Disabled**.

Summary Screen

This setting allows you to **Enable** or Disable the summary screen which displays the system configuration during bootup.

► Memory Cache

Cache System BIOS Area

This setting allows you to designate a reserve area in the system memory to be used as a System BIOS buffer to allow the BIOS to write (cache) its data into this reserved memory area. Select **Write Protect** to enable the function and reserve this area for the Video BIOS ROM access only. Select Uncached to disable this function and make this area available for other devices.

Cache Video BIOS Area

This setting allows you to designate a reserve area in the system memory to be used as a Video BIOS buffer to allow the BIOS to write (cache) its data into this reserved memory area. Select **Write Protect** to enable the function and reserve this area for the Video BIOS ROM access only. Select Uncached to disable this function and make this area available for other devices.

Cache Base 0-512K

If enabled, this feature will allow the data stored in the base memory area: block 0-512K to be cached (written) into a buffer, a storage area in the Static DRAM (SDRAM) or to be written into L1, L2 cache inside the CPU to speed up CPU operations. Select Uncached to disable this function. Select Write Through to allow data to be cached into the buffer and written into the system memory at the same time. Select Write Protect to prevent data from being written into the base memory area of Block 0-512K. Select Write Back to allow the CPU to write data back directly from the buffer without writing data to the System Memory for fast CPU data processing and operation. The options are Uncached, Write Through, Write Protect, and **Write Back**.

Cache Base 512K-640K

If enabled, this feature will allow the data stored in the memory area: 512K-640K to be cached (written) into a buffer, a storage area in the Static DRAM (SDRAM) or written into L1, L2 or L3 cache inside the CPU to speed up CPU operations. Select Uncached to disable this function. Select Write Through to allow data to be cached into the buffer and written into the system memory at the same time. Select Write Protect to prevent data from being written into the base memory area of Block 512-640K. Select Write Back to allow the CPU to write data back directly from the buffer without writing data to the system memory to speed up CPU's operation. The options are Uncached, Write Through, Write Protect, and **Write Back**.

Cache Extended Memory

If enabled, this feature will allow the data stored in the extended memory area to

be cached (written) into a buffer, a storage area in the Static DROM (SDROM) or written into L1, L2, L3 cache inside the CPU to speed up CPU operations. Select **Uncached** to disable this function. Select **Write Through** to allow data to be cached into the buffer and written into the system memory at the same time. Select **Write Protect** to prevent data from being written into the extended memory area above 1 MB. Select **Write Back** to allow the CPU to write data back directly from the buffer without writing data to the System Memory for fast CPU data processing and operation. The options are **Uncached**, **Write Through**, **Write Protect**, and **Write Back**.

Discrete MTRR Allocation

If enabled, MTRRs (-Memory Type Range Registers) are configured as distinct, separate units and cannot be overlapped. If enabled, the user can achieve better graphic effects when using a Linux graphic driver that requires the write-combining configuration with 4GB or more memory. The options are **Enabled** and **Disabled**.

►PCI Configuration

Access the submenu to make changes to the following settings for PCI devices.

Onboard GLAN1/Onboard GLAN2 (Gigabit- LAN) OPROM Configure

Select **Enabled** to allow the system to boot from the GLAN1 connection or the GLAN 2 connection. The options are **Enabled** and **Disabled**.

IPMI 3rd-LAN OPROM Configure

Select **Enabled** to allow the system to boot from the IPMI 3rd-LAN connection. The options are **Disabled** and **Enabled**.

Onboard Storage OPROM Configure

Select **Enabled** to allow the system to boot from the onboard storage device. The options are **Disabled** and **Enabled**.

Option ROM Replacement

Select **Enabled** to enable to use the feature of Option ROM Chip Replacement. If the system hangs due to this feature, reboot the system and change the setting. The options are **Enabled** and **Disabled**.

ROM Scan Ordering

This feature allows the user to decide which Option ROM to be activated first. The options are **Onboard first** and **Add-On first**.

PCI Parity Error Forwarding

Enable this item to forward the PCI errors occurring behind P2P bridges to the South Bridge, so NMI can be asserted. The options are Enabled and **Disabled**.

PCI Fast Delayed Transaction

Enable this function to improve the DMA data transfer rate for a PCI 32-bit multimedia card. The options are Enable and **Disabled**.

Reset Configuration Data

If set to Yes, this setting clears the Extended System Configuration Data- (ESCD) area. The options are Yes and **No**.

Frequency for PCI-X#1~PCI-X#2

This option allows the user to change the bus frequency for the devices installed in the slot indicated. The options are **Auto**, PCI 33 MHz, PCI 66 MHz, PCI-X 66 MHz, PCI-X 100 MHz, and PCI-X 133 MHz.

► Slot0 PCI-U x8, Slot1 PCI-X 133 MHz, Slot2 PCI-X 133MHz, Slot3 PCI-Exp x8, Slot4 PCI-Exp x4, Slot5 PCI-Exp x8, and Slot6 PCI-Exp x8

Access the submenu for each of the settings above to make changes to the following:

Option ROM Scan

When enabled, this setting will initialize the device expansion ROM. The options are **Enabled** and Disabled.

Enable Master

This setting allows you to enable the selected device as the PCI bus master. The options are **Enabled** and Disabled.

Latency Timer

This setting allows you to set the clock rate for Bus Master. A high-priority, high-throughput device may benefit from a greater clock rate. The options are **Default**, 0020h, 0040h, 0060h, 0080h, 00A0h, 00C0h, and 00E0h. For Unix, Novell and other Operating Systems, please select the option: other. If a drive fails after the installation of a new software, you might want to change this setting and try again. A different OS requires a different Bus Master clock rate.

Large Disk Access Mode

This setting determines how large hard drives are to be accessed. The options are

DOS or Other (for Unix, Novelle NetWare and other operating systems).

► **Advanced Chipset Control**

Access the submenu to make changes to the following settings.



Warning: Take caution when changing the Advanced settings. An Incorrect value, a very high DRAM frequency or an incorrect DRAM timing may cause system to become unstable. When this occurs, reset the setting to the default setting.

SERR Signal Condition

This setting specifies the ECC Error conditions that an SERR# is to be asserted. The options are None, **Single Bit**, Multiple Bit, and Both.

Clock Spectrum Feature

If Enabled, the BIOS will monitor the level of Electromagnetic Interference caused by the components and will attempt to decrease the interference whenever needed. The options are Enabled and **Disabled**.

► **Intel VT for Direct I/O (VT-d)**

Select Enable to enable the functionality of the Intel Virtualization Technology for Direct I/O VT-d support by reporting the I/O device assignment to VMM through the DMAR ACPI Tables. This feature offers fully-protected I/O resource-sharing across the Intel platforms, providing the user with greater reliability, security and availability in networking and data-sharing. The settings are Enabled and **Disabled**. Press the <Enter> key to enter the submenu. The following items will appear:

VT-d for Port 0 (ESI)

VT-d for Port 1

VT-d for Port 3

VT-d for Port 5

VT-d for Port 7

VT-d for Port 9

Select Enable to enable Intel VT-d support for Port 0(ESI), Port 3, Port 5, Port 7, Port 9 through using DRHD structures located in the ACPI Tables.

4GB PCI Hole Granularity

This feature allows you to select the granularity of PCI hole for PCI slots. If MTRRs are not enough, this option may be used to reduce MTRR occupation. The options are: **256 MB**, 512 MB, 1GB and 2GB.

Memory Voltage

Select Auto to allow the BIOS to automatically detect memory voltage based on the SPD table. Select 1.5V to force the system to use 1.5V for lower power fully-buffered DIMM modules. Select 1.8V to use 1.8V power for onboard memory modules. Note: Using 1.8V might cause damage to the memory modules that only support 1.5V power. The options are: **Auto**, 1.5V and 1.8V.

Memory Branch Mode

This option determines how the two memory branches operate. System address space can either be interleaved between the two branches or Sequential from one branch to another. Mirror mode allows data correction by maintaining two copies of data in two branches. Single Channel 0 allows a single DIMM population during system manufacturing. The options are **Interleave**, Sequential, Mirroring, and Single Channel 0.

Branch 0 Rank Sparing/Branch 1 Rank Sparing

Select **Enable** to enable the function of memory sparing for Memory Bus Branch 0 or Branch 1. The options are Enabled and **Disabled**.

Branch 0 Rank Interleaving/Branch 1 Rank Interleaving

Select enable to enable Interleaved Memory for Memory Bus Branch 0 Rank or Branch 1 Rank. The options for Memory Interleaving are 1:1, 2:1 and **4:1**.

Enhanced x8 Detection

Select **Enabled** to enable Enhanced x8 DRAM UC Error Detection. The options are Disabled and **Enabled**.

Demand Scrub

Scrubbing is a process that allows the North Bridge to correct correctable memory errors found on an FBD memory module. When the CPU or I/O issues a demand-read command, and the read data from memory turns out to be a correctable ECC, it is corrected and sent to the original source. Memory is updated as well. Select Enabled to use Demand Scrubbing for ECC memory correction. The options are **Enabled** and Disabled.

High Temperature DRAM Operation

When set to Enabled, the BIOS will refer to the SPD table to set the maximum DRAM temperature. If disabled, the BIOS will set the maximum DRAM temperature based on a predefined value. The options are Enabled and **Disabled**.

AMB Thermal Sensor

Select Enabled to enable the thermal sensor embedded in the Advanced Memory Buffer on a fully buffered memory module for thermal monitoring. The options are **Disabled** and Enabled.

Thermal Throttle

Select Enabled to enable closed-loop thermal throttling on a fully buffered (FBD) memory module. In the closed-loop thermal environment, thermal throttling will be activated when the temperature of the FBD DIMM module exceeds a predefined threshold. The options are Enabled and **Disabled**.

Global Activation Throttle

Select Enabled to enable the function of open-loop global thermal throttling on the fully buffered (FBD) memory modules and allow global thermal throttling to become active when the number of activate control exceeds a predefined number. The options are Enabled and **Disabled**.

Force ITK Configuration Clocking

Select Enabled to configure FBD clock settings to support ITK testing. The options are **Disabled** and Enabled.

Reserved Branch for ITK Test

This feature allows the user to specify the memory branch number to be reserved for ITK testing. The default setting is **Branch 1**.

Snoop Filter

Select Enabled to eliminate snoop traffic to the graphics port to greatly improve system performance when running graphics intensive applications. The options are **Enabled** and Disabled.

Crystal Beach Features

Select **Enabled** to use the Intel I/O AT (Acceleration Technology) to accelerate the performance of TOE devices. (Note: A TOE device is a specialized, dedicated processor that is installed on an add-on card or a network card to handle some or all packet processing of this add-on card. For this motherboard, the TOE device is built inside the ESB 2 South Bridge chip.) The options are **Enabled** and Disabled.

Route Port 80h Cycles to

This feature allows the user to decide which bus to send debug information to. The options are Disabled, PCI and **LPC**.

High Precision Event Time

Select Yes to activate the High Precision Event Timer (HPET), which is capable of producing periodic interrupts at a much higher frequency than a Real-time Clock (RTC) can in synchronizing multimedia streams, providing smooth playback and reducing the dependency on other timestamp calculation devices, such as an x86 RDTSC Instruction embedded in a CPU. The High Precision Event Timer is used to replace the 8254 Programmable Interval Timer. The options for this feature are Yes and **No**.

USB Function

Select Enabled to enable the function of USB devices specified. The settings are **Enabled** and Disabled.

Legacy USB Support

This setting allows you to enable support for Legacy USB devices. The settings are **Enabled** and Disabled.

► Advanced Processor Options

Access the submenu to make changes to the following settings.

CPU Speed

This is a display that indicates the speed of the installed processor.

Frequency Ratio (Available when supported by the CPU.)

The feature allows the user to set the internal frequency multiplier for the CPU. The options are: **Default**, x12, x13, x14, x15, x16, x17 and x18.

Core-Multi-Processing (Available when supported by the CPU.)

Set to Enabled to use a processor's Second Core and beyond. (Please refer to Intel's web site for more information.) The options are Disabled and **Enabled**.

Machine Checking (Available when supported by the CPU.)

Set to Enabled to activate the function of Machine Checking and allow the CPU to detect and report hardware (machine) errors via a set of model-specific registers (MSRs). The options are Enabled and **Disabled**.

Fast String Operations (Available if supported by the CPU.)

Set to **Enabled** to enable the fast string operations for special CPU instructions. The options are Disabled and **Enabled**.

C1/C2 Enhanced Mode (Available when supported by the CPU.)

Set to Enabled to enable Enhanced Halt State to lower CPU voltage/frequency to prevent overheat. The options are Enabled and **Disabled**. (**Note:** please refer to Intel's web site for detailed information.)

Execute Disable Bit (Available when supported by the CPU and the OS.)

Set to Enabled to enable Execute Disable Bit and allow the processor to classify areas in memory where an application code can execute and where it cannot, and thus preventing a worm or a virus from inserting and creating a flood of codes to overwhelm the processor or damage the system during an attack. **Note:** this feature is available when your OS and your CPU support the function of Execute Disable Bit. The options are **Disabled** and Enabled. For more information, please refer to Intel's and Microsoft's web sites.

Adjacent Cache Line Prefetch (Available when supported by the CPU.)

The CPU fetches the cache line for 64 bytes if this option is set to Disabled. The CPU fetches both cache lines for 128 bytes as comprised if Enabled. The options are **Disabled** and Enabled.

Hardware Prefetch (Available if supported by the CPU.)

Set to this option to **Enabled** to enable the hardware components that are used in conjunction with software programs to prefetch data in order to speed up data processing. The options are Disabled and **Enabled**.

Set Maximum Ext. CPUID=3

When set to Enabled, the Maximum Extended CPUID will be set to 3. The options are **Disabled** and Enabled.

Direct Cache Access (Available when supported by the CPU.)

Set to Enable to route inbound network IO traffic directly into processor caches to reduce memory latency and improve network performance. The options are **Disabled** and Enabled.

DCA Delay Clocks (Available when supported by the CPU.)

This feature allows the user to set the clock delay setting from snoop to prefetch for Direct Cache Access. Select a setting from 8 (bus cycles) to 120 (bus cycles) (in 8-cycle increment). The default setting is **32 (bus cycles)**.

Intel <R> Virtualization Technology (Available when supported by the CPU.)

Select Enabled to use the feature of Virtualization Technology to allow one platform to run multiple operating systems and applications in independent partitions, creating

multiple "virtual" systems in one physical computer. The options are Enabled and **Disabled**. (**Note:** If there is any change to this setting, you will need to power off and restart the system for the change to take effect.) Please refer to Intel's web site for detailed information.

Intel EIST Support (Available when supported by the CPU.)

Select Enabled to use the Enhanced Intel SpeedStep Technology and allows the system to automatically adjust processor voltage and core frequency in an effort to reduce power consumption and heat dissipation. The options are Enabled and **Disabled**. Please refer to Intel's web site for detailed information.

SMRR Support (Available when supported by the CPU.)

Select Enabled to use a new CPU security feature to prevent viruses accessing the System Management Module (SMM). When set to Enabled, the SM Memory Region will become uncacheable, effectively preventing viruses from modifying or corrupting critical system parameters. The options are Enabled and **Disabled**. Please refer to Intel's web site for detailed information.

► I/O Device Configuration

Access the submenu to make changes to the following settings.

KBC Clock Input

This setting allows you to select clock frequency for KBC. The options are 6MHz, 8MHz, **12MHz**, and 16MHz.

Serial Port A

This setting allows you to assign control of serial port A. The options are **Enabled** (user defined), Disabled, and Auto (BIOS- or OS- controlled).

Base I/O Address

This setting allows you to select the base I/O address for serial port A. The options are **3F8**, 2F8, 3E8, and 2E8.

Interrupt

This setting allows you to select the IRQ (interrupt request) for serial port A. The options are IRQ3 and **IRQ4**.

Serial Port B

This setting allows you to assign control of serial port B. The options are **Enabled** (user defined), Disabled, Auto (BIOS controlled) and OS Controlled.

Mode

This setting allows you to set the type of device that will be connected to serial port B. The options are **Normal** and IR (for an infrared device).

Base I/O Address

This setting allows you to select the base I/O address for serial port B. The options are 3F8, **2F8**, 3E8 and 2E8.

Interrupt

This setting allows you to select the IRQ (interrupt request) for serial port B. The options are **IRQ3** and IRQ4.

Parallel Port

This setting allows you to assign control of the parallel port. The options are **Enabled** (user defined), Disabled and Auto (BIOS-or OS- controlled).

Base I/O Address

Select the base I/O address for the parallel port. The options are **378**, 278 and 3BC.

Interrupt

This setting allows you to select the IRQ (interrupt request) for the parallel port. The options are IRQ5 and **IRQ7**.

Mode

This feature allows you to specify the parallel port mode. The options are Output only, Bi-Directional, EPP and **ECP**.

DMA Channel

This item allows you to specify the DMA channel for the parallel port. The options are DMA1 and **DMA3**.

Floppy Disk Controller

This setting allows you to assign control of the floppy disk controller. The options are **Enabled** (user defined), Disabled, and Auto (BIOS and OS controlled).

Base I/O Address

This setting allows you to select the base I/O address for the Floppy port. The options are **Primary** and Secondary.

► DMI Event Logging

Access the submenu to make changes to the following settings.

Event Log Validity

This is a display to inform you of the event log validity. It is not a setting.

Event Log Capacity

This is a display to inform you of the event log capacity. It is not a setting.

View DMI Event Log

Highlight this item and press <Enter> to view the contents of the event log.

Event Logging

This setting allows you to **Enable** or Disable event logging.

ECC Event Logging

This setting allows you to **Enable** or Disable ECC event logging.

Mark DMI Events as Read

Highlight this item and press <Enter> to mark the DMI events as read.

Clear All DMI Event Logs

Select Yes and press <Enter> to clear all DMI event logs. The options are Yes and **No**.

► Console Redirection

Access the submenu to make changes to the following settings.

COM Port Address

This item allows you to specify which COM port to direct the remote console to: Onboard COM A or Onboard COM B. This setting can also be **Disabled**.

BAUD Rate

This item allows you to set the BAUD rate for console redirection. The options are 300, 1200, 2400, 9600, **19.2K**, 38.4K, 57.6K, and 115.2K.

Console Type

This item allows you to set console redirection type. The options are VT100, VT100/8bit, PC-ANSI/7bit, **PC ANSI**, VT100+, VT-UTF8 and ASCII.

Flow Control

This item allows you to select the flow control option for the console. The options are: None, XON/XOFF, and **CTS/RTS**.

Console Connection

This item allows you to decide how console redirection is to be connected: either **Direct** or Via Modem.

Continue CR after POST

Select on to continue with console redirection after the POST routine. The options are On and **Off**.

► Hardware Monitor Logic

Highlight this and hit <Enter> to see the status for the following items:

CPU1 Temperature/CPU2 Temperature/System Temperature

Fan1-Fan8 Speeds:

If the feature of Auto Fan Control is enabled, the BIOS will automatically display the status of the fans indicated in this item.

Fan Speed Control Modes

This feature allows the user to decide how the system controls the speeds of the onboard fans. The CPU temperature and the fan speed are correlative. When the CPU on-die temperature increases, the fan speed will also increase, and vice versa. Select Workstation if your system is used as a Workstation. Select Server if your system is used as a Server. Select 3-pin if your chassis uses 3-pin fans. Select 4-pin if your chassis uses 4-pin fans. Select "Disable" to disable the fan speed control function and allow the onboard fans to constantly run at the full speed (12V). The Options are: **1. Running at the Full Speed**, 2. Optimized Server w/3-pin, 3. Optimized Workstation w/3-pin, 4. Optimized Server w/4-pin, and 5. Optimized Workstation w/4-pin.

Voltage Monitoring

The following items will be monitored and displayed:

VcoreA/VcoreB

+12V/-12V

+5Vsb/+5VDD

+3.3V

P1V5/P_VTT/Vbat

Note: In the Windows OS environment, the Supero Doctor III settings take precedence over the BIOS settings. When first installed, Supero Doctor III adopts the temperature threshold settings previously set in the BIOS. Any subsequent changes to these thresholds must be made within Supero Doctor, since the SD III settings override the BIOS settings. For the Windows OS to adopt the BIOS temperature threshold settings, please change the SDIII settings to be the same as those set in the BIOS.

► **IPMI (The option is available only when an IPMI card is installed in the system.)**

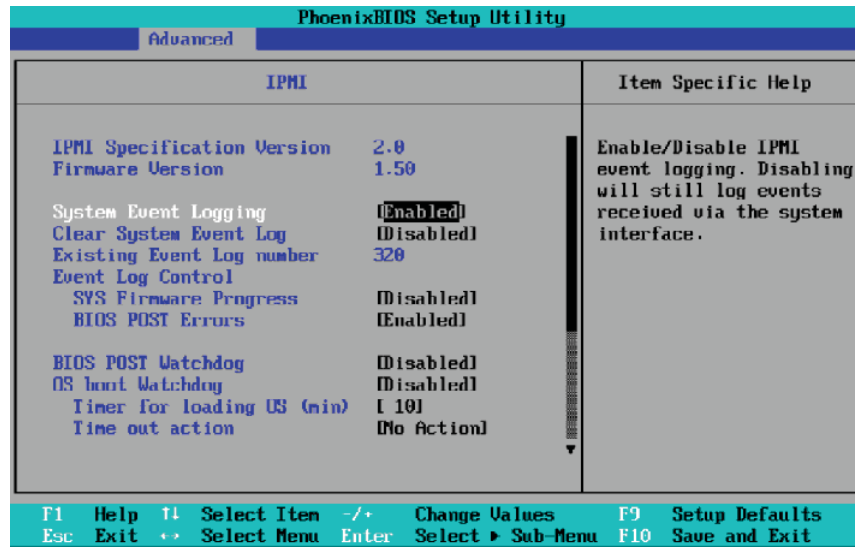

IPMI Specification Version: This item displays the current IPMI Version.

Firmware Version: This item displays the current Firmware Version.

System Event Logging

Select Enabled to enable IPMI Event Logging. When this function is set to Disabled, the system will continue to log events received via system interface. The options are **Enabled** and Disabled.

Clear System Event Logging

Enabling this function to force the BIOS to clear the system event logs during the next cold boot. The options are Enabled and **Disabled**.

Existing Event Log Number

This item displays the number of the existing event log.

Event Log Control

System Firmware Progress

Enabling this function to log POST progress. The options are Enabled and **Disabled**.

BIOS POST Errors

Enabling this function to log POST errors. The options are Enabled and **Disabled**.

BIOS POST Watch Dog

Set to Enabled to enable POST Watch Dog. The options are Enabled and **Disabled**.

OS Boot Watch Dog

Set to Enabled to enable OS Boot Watch Dog. The options are Enabled and **Disabled**.

Timer for Loading OS (Minutes)

This feature allows the user to set the time value (in minutes) for the previous item: OS Boot Watch Dog by keying-in a desired number in the blank. The default setting is 10 (minutes.) (Please ignore this option when OS Boot Watch Dog is set to "Disabled".)

Time Out Option

This feature allows the user to determine what action to take in an event of a system boot failure. The options are **No Action**, Reset, Power Off and Power Cycles.

► System Event Log/System Event Log (List Mode)

These options display the System Event (SEL) Log and System Event (SEL) Log in List Mode. Items include: SEL (System Event Log) Entry Number, SEL Record ID, SEL Record Type, Time Stamp, Generator ID, SEL Message Revision, Sensor Type, Sensor Number, SEL Event Type, Event Description, and SEL Event Data.

Event ID	Sensor Name	Sensor Type	Date/Time Stamp
▶ 0001	UBAT	Fan	000000BC
	Lower Non-critical Going Low, Assertion		
▶ 0002	UBAT	Fan	000000BC
	Lower Critical Going Low, Assertion		
▶ 0003	UBAT	Fan	000000BC
	Lower Non-recoverable Going Low, Assertion		
▶ 0004	Fan1	Fan	000000BC
	Lower Non-critical Going Low, Assertion		
▶ 0005	Fan1	Fan	000000BC
	Lower Critical Going Low, Assertion		
▶ 0006	Fan1	Fan	000000BC
	Lower Non-recoverable Going Low, Assertion		

F1 Help F2 Select Item F3 Change Values F9 Setup Defaults
 Esc Exit F4 Select Menu Enter Select Sub-Menu F10 Save and Exit

► Realtime Sensor Data

This feature display information from motherboard sensors, such as temperatures, fan speeds and voltages of various components.

PhoenixBIOS Setup Utility					
Advanced					
Realtime Sensor Data					
Sensor Type	Sensor Name	Sensor Data	Sensor Units	Lower Limit	Upper Limit
Temp	CPU Temp 1	0.00	degrees C	0.00	75.00
	CPU Temp 2	0.00	degrees C	0.00	75.00
	CPU Temp 3	0.00	degrees C	0.00	75.00
	CPU Temp 4	0.00	degrees C	0.00	75.00
	Sys Temp	31.00	degrees C	0.00	75.00
Voltage	CPU1 Ucore	0.00	Volts	0.70	1.61
	CPU2 Ucore	1.07	Volts	0.70	1.61
	3.3V	3.24	Volts	2.96	3.63

F1	Help	F4	Select Item	-/+	Change Values	F9	Setup Defaults
Esc	Exit	→	Select Menu	Enter	Select ► Sub-Menu	F10	Save and Exit

The following items will also appear:

IP Address,

IP Subnet Mask,

Default Gateway,

MAC Address Byte0,

MAC Address Byte1,

MAC Address Byte2,

MAC Address Byte3,

MAC Address Byte4,

MAC Address Byte5,

► IPMI LAN Configuration

The following features allow the user to configure and monitor IPMI LAN settings.

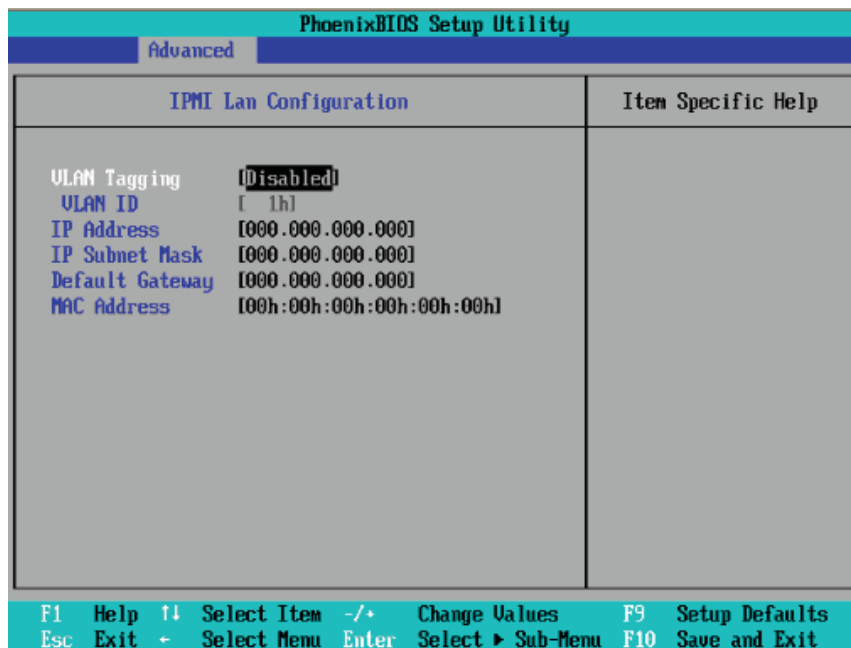

VLAN Tagging

Select Enabled to enable Virtual LAN(s) for IPMI connections and allow the user to configure VLAN settings. The options are Enabled and **Disabled**.

VLAN ID

If VLAN Tagging above is set to Enabled, this item allows the user to change the VLAN ID. If VLAN Tagging is disabled, this item will be ignored by the firmware.

IP Address

This item displays the IP address for the IPMI connection detected.

IP Subnet Mask

This item displays the IP Subnet Mask for the IPMI connection detected.

Default Gateway

This item displays the Default Gateway for the IPMI connection detected.

MAC Address

This item displays the MAC Address for the IPMI connection detected.

7-5 Security

Choose Security from the Phoenix BIOS Setup Utility main menu with the arrow keys. You should see the following display. Security setting options are displayed by highlighting the setting using the arrow keys and pressing <Enter>. All Security BIOS settings are described in this section.

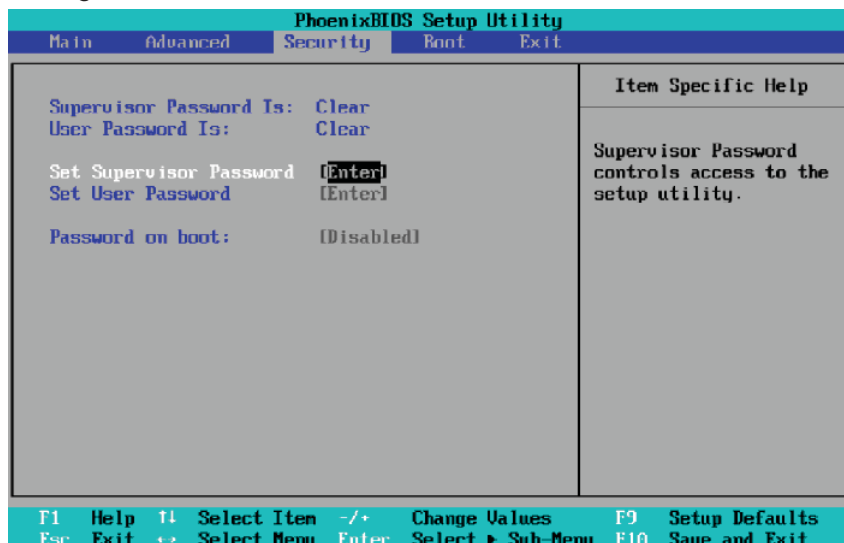

Supervisor Password Is:

This feature indicates if a supervisor password has been entered to the system. Clear means such a password has not been used, and Set means a supervisor password has been entered.

User Password Is:

This feature indicates if a user password has been entered to the system. Clear means such a password has not been used, and Set means a user password has been entered.

Set Supervisor Password

When the item Set "Supervisor Password" is highlighted, hit the <Enter> key. When prompted, type the Supervisor's password in the dialogue box to set or to change supervisor's password, which allows access to the BIOS.

Set User Password

When the item "Set User Password" is highlighted, hit the <Enter> key. When prompted, type the user's password in the dialogue box to set or to change the user's password, which allows access to the system at boot-up.

Password on Boot

This setting allows you to determine if a password is required for a user to enter the system at bootup. The options are **Enabled** (password required) and Disabled.

7-6 Boot

Choose Boot from the Phoenix BIOS Setup Utility main menu with the arrow keys. You should see the following display. See details on how to change the order and specs of boot devices in the Item Specific Help window. All Boot BIOS settings are described in this section.

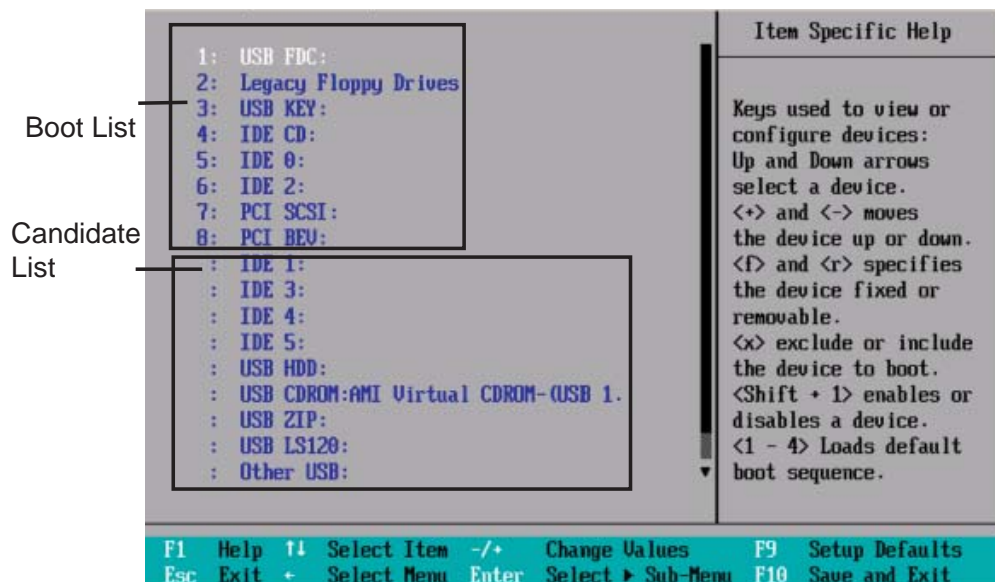

Boot Priority Order/Excluded from Boot Orders

The devices included in the boot list section (above) are bootable devices listed in the sequence of boot order as specified. The boot functions for the devices included in the candidate list (above) are currently disabled. Use a <+> key or a <-> key to move the device up or down. Use the <f> key or the <r> key to specify the type of an USB device, either fixed or removable. You can select one item from the boot list and hit the <x> key to remove it from the list of bootable devices (to make its resource available for other bootable devices). Subsequently, you can select an item from the candidate list and hit the <x> key to remove it from the candidate list and put it in the boot list. This item will then become a bootable device. See details on how to change the priority of boot order of devices in the "Item Specific Help" window.

7-7 Exit

Choose Exit from the Phoenix BIOS Setup Utility main menu with the arrow keys. You should see the following display. All Exit BIOS settings are described in this section.

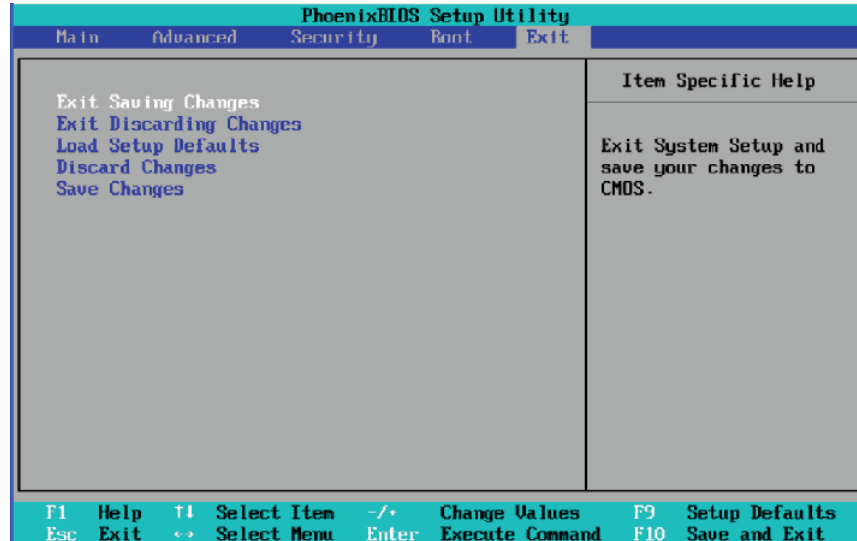

Exit Saving Changes

Highlight this item and hit <Enter> to save any changes you made and to exit the BIOS Setup utility.

Exit Discarding Changes

Highlight this item and hit <Enter> to exit the BIOS Setup utility without saving any changes you may have made.

Load Setup Defaults

Highlight this item and hit <Enter> to load the default settings for all items in the BIOS Setup. These are the safest settings to use.

Discard Changes

Highlight this item and hit <Enter> to discard (cancel) any changes you've made. You will remain in the Setup utility.

Save Changes

Highlight this item and hit <Enter> to save any changes you made. You will remain in the Setup utility.

Notes

Appendix A

BIOS POST Messages

During the Power-On Self-Test (POST), the BIOS will check for problems. If a problem is found, the BIOS will activate an alarm or display a message. The following is a list of such BIOS messages.

Failure Fixed Disk

Fixed disk is not working or not configured properly. Check to see if fixed disk is attached properly. Run Setup. Find out if the fixed-disk type is correctly identified.

Stuck key

Stuck key on keyboard.

Keyboard error

Keyboard not working.

Keyboard Controller Failed

Keyboard controller failed test. May require replacing keyboard controller.

Keyboard locked - Unlock key switch

Unlock the system to proceed.

Monitor type does not match CMOS - Run SETUP

Monitor type not correctly identified in Setup

Shadow Ram Failed at offset: nnnn

Shadow RAM failed at offset **nnnn** of the 64k block at which the error was detected.

System RAM Failed at offset: nnnn

System RAM failed at offset **nnnn** of in the 64k block at which the error was detected.

Extended RAM Failed at offset: nnnn

Extended memory not working or not configured properly at offset **nnnn**.

System battery is dead - Replace and run SETUP

The CMOS clock battery indicator shows the battery is dead. Replace the battery and run Setup to reconfigure the system.

System CMOS checksum bad - Default configuration used

System CMOS has been corrupted or modified incorrectly, perhaps by an application program that changes data stored in CMOS. The BIOS installed Default Setup Values. If you do not want these values, enter Setup and enter your own values. If the error persists, check the system battery or contact your dealer.

System timer error

The timer test failed. Requires repair of system board.

Real time clock error

Real-Time Clock fails BIOS hardware test. May require board repair.

Check date and time settings

BIOS found date or time out of range and reset the Real-Time Clock. May require setting legal date (1991-2099).

Previous boot incomplete - Default configuration used

Previous POST did not complete successfully. POST loads default values and offers to run Setup. If the failure was caused by incorrect values and they are not corrected, the next boot will likely fail. On systems with control of **wait states**, improper Setup settings can also terminate POST and cause this error on the next boot. Run Setup and verify that the waitstate configuration is correct. This error is cleared the next time the system is booted.

Memory Size found by POST differed from CMOS

Memory size found by POST differed from CMOS.

Diskette drive A error

Diskette drive B error

Drive A: or B: is present but fails the BIOS POST diskette tests. Check to see that the drive is defined with the proper diskette type in Setup and that the diskette drive is attached correctly.

Incorrect Drive A type - run SETUP

Type of floppy drive A: not correctly identified in Setup.

Incorrect Drive B type - run SETUP

Type of floppy drive B: not correctly identified in Setup.

System cache error - Cache disabled

RAM cache failed and BIOS disabled the cache. On older boards, check the cache jumpers. You may have to replace the cache. See your dealer. A disabled cache slows system performance considerably.

CPU ID:

CPU socket number for Multi-Processor error.

EISA CMOS not writeable

ServerBIOS2 test error: Cannot write to EISA CMOS.

DMA Test Failed

ServerBIOS2 test error: Cannot write to extended **DMA** (Direct Memory Access) registers.

Software NMI Failed

ServerBIOS2 test error: Cannot generate software NMI (Non-Maskable Interrupt).

Fail-Safe Timer NMI Failed

ServerBIOS2 test error: Fail-Safe Timer takes too long.

Device Address Conflict

Address conflict for specified **device**.

Allocation Error for: device

Run ISA or EISA Configuration Utility to resolve resource conflict for the specified **device**.

CD ROM Drive

CD ROM Drive identified.

Entering SETUP ...

Starting Setup program

Failing Bits: nnnn

The hex number **nnnn** is a map of the bits at the RAM address which failed the memory test. Each 1 (one) in the map indicates a failed bit. See errors 230, 231, or 232 above for offset address of the failure in System, Extended, or Shadow memory.

Fixed Disk n

Fixed disk **n** (0-3) identified.

Invalid System Configuration Data

Problem with NVRAM (CMOS) data.

I/O device IRQ conflict

I/O device IRQ conflict error.

PS/2 Mouse Boot Summary Screen:

PS/2 Mouse installed.

nnnn kB Extended RAM Passed

Where **nnnn** is the amount of RAM in kilobytes successfully tested.

nnnn Cache SRAM Passed

Where **nnnn** is the amount of system cache in kilobytes successfully tested.

nnnn kB Shadow RAM Passed

Where **nnnn** is the amount of shadow RAM in kilobytes successfully tested.

nnnn kB System RAM Passed

Where **nnnn** is the amount of system RAM in kilobytes successfully tested.

One or more I2O Block Storage Devices were excluded from the Setup Boot Menu

There was not enough room in the IPL table to display all installed I2O block-storage devices.

Operating system not found

Operating system cannot be located on either drive A: or drive C:. Enter Setup and see if fixed disk and drive A: are properly identified.

Parity Check 1 nnnn

Parity error found in the system bus. BIOS attempts to locate the address and display it on the screen. If it cannot locate the address, it displays **????**. Parity is a method for checking errors in binary data. A parity error indicates that some data has been corrupted.

Parity Check 2 nnnn

Parity error found in the I/O bus. BIOS attempts to locate the address and display it on the screen. If it cannot locate the address, it displays **????**.

Press <F1> to resume, <F2> to Setup, <F3> for previous

Displayed after any recoverable error message. Press <F1> to start the boot process or <F2> to enter Setup and change the settings. Press <F3> to display the previous screen (usually an initialization error of an **Option ROM**, i.e., an add-on card). Write down and follow the information shown on the screen.

Press <F2> to enter Setup

Optional message displayed during POST. Can be turned off in Setup.

PS/2 Mouse:

PS/2 mouse identified.

Run the I2O Configuration Utility

One or more unclaimed block storage devices have the Configuration Request bit set in the LCT. Run an I2O Configuration Utility (e.g. the SAC utility).

System BIOS shadowed

System BIOS copied to shadow RAM.

UMB upper limit segment address: *nnnn*

Displays the address *nnnn* of the upper limit of **Upper Memory Blocks**, indicating released segments of the BIOS which can be reclaimed by a virtual memory manager.

Video BIOS shadowed

Video BIOS successfully copied to shadow RAM.

Notes

Appendix B

BIOS POST Codes

This section lists the POST (Power On Self Test) codes for the Phoenix BIOS. POST codes are divided into two categories: recoverable and terminal.

Recoverable POST Errors

When a recoverable type of error occurs during POST, the BIOS will display an POST code that describes the problem. BIOS may also issue one of the following beep codes:

- 1 long and two short beeps - video configuration error
- 1 repetitive long beep - no memory detected

Terminal POST Errors

If a terminal type of error occurs, BIOS will shut down the system. Before doing so, BIOS will write the error to port 80h, attempt to initialize video and write the error in the top left corner of the screen. The following is a list of codes that may be written to port 80h.

POST Code Description

01h	IPMI Initialization
02h	Verify Real Mode
03h	Disable Non-Maskable Interrupt (NMI)
04h	Get CPU type
06h	Initialize system hardware
07h	Disable shadow and execute code from the ROM.
08h	Initialize chipset with initial POST values
09h	Set IN POST flag
0Ah	Initialize CPU registers
0Bh	Enable CPU cache
0Ch	Initialize caches to initial POST values
0Eh	Initialize I/O component
0Fh	Initialize the local bus IDE
10h	Initialize Power Management
11h	Load alternate registers with initial POST values
12h	Restore CPU control word during warm boot
13h	Reset PCI Bus Mastering devices
14h	Initialize keyboard controller
16h	1-2-2-3 BIOS ROM checksum
17h	Initialize cache before memory Auto size

POST Code Description

18h	8254 timer initialization
1Ah	8237 DMA controller initialization
1Ch	Reset Programmable Interrupt Controller
20h	1-3-1-1 Test DRAM refresh
22h	1-3-1-3 Test 8742 Keyboard Controller
24h	Set ES segment register to 4 GB
28h	Auto size DRAM
29h	Initialize POST Memory Manager
2Ah	Clear 512 kB base RAM
2Ch	1-3-4-1 RAM failure on address line xxxx*
2Eh	1-3-4-3 RAM failure on data bits xxxx* of low byte of memory bus
2Fh	Enable cache before system BIOS shadow
32h	Test CPU bus-clock frequency
33h	Initialize Phoenix Dispatch Manager
36h	Warm start shut down
38h	Shadow system BIOS ROM
3Ah	Auto size cache
3Ch	Advanced configuration of chipset registers
3Dh	Load alternate registers with CMOS values
41h	Initialize extended memory for RomPilot (optional)
42h	Initialize interrupt vectors
45h	POST device initialization
46h	2-1-2-3 Check ROM copyright notice
48h	Check video configuration against CMOS
49h	Initialize PCI bus and devices
4Ah	Initialize all video adapters in system
4Bh	QuietBoot start (optional)
4Ch	Shadow video BIOS ROM
4Eh	Display BIOS copyright notice
4Fh	Initialize MultiBoot
50h	Display CPU type and speed
51h	Initialize EISA board (optional)
52h	Test keyboard
54h	Set key click if enabled
55h	Enable USB devices
58h	2-2-3-1 Test for unexpected interrupts
59h	Initialize POST display service
5Ah	Display prompt "Press <ESC> to enter SETUP"
5Bh	Disable CPU cache

POST Code	Description
5Ch	Test RAM between 512 and 640 kB
60h	Test extended memory
62h	Test extended memory address lines
64h	Jump to UserPatch1
66h	Configure advanced cache registers
67h	Initialize Multi Processor APIC
68h	Enable external and CPU caches
69h	Setup System Management Mode (SMM) area
6Ah	Display external L2 cache size
6Bh	Load custom defaults (optional)
6Ch	Display shadow-area message
70h	Display error messages
72h	Check for configuration errors
76h	Check for keyboard errors
7Ch	Set up hardware interrupt vectors
7Dh	Initialize Intelligent System Monitoring (optional)
7Eh	Initialize coprocessor if present
80h	Disable onboard Super I/O ports and IRQs (optional)
81h	Late POST device initialization
82h	Detect and install external RS232 ports
83h	Configure non-MCD IDE controllers
84h	Detect and install external parallel ports
85h	Initialize PC-compatible PnP ISA devices
86h	Re-initialize onboard I/O ports.
87h	Configure Motherboard Configurable Devices (optional)
88h	Initialize BIOS Data Area
89h	Enable Non-Maskable Interrupts (NMIs)
8Ah	Initialize Extended BIOS Data Area
8Bh	Test and initialize PS/2 mouse
8Ch	Initialize floppy controller
8Fh	Determine number of ATA drives (optional)
90h	Initialize hard-disk controllers
91h	Initialize local-bus hard-disk controllers
92h	Jump to UserPatch2
93h	Build MPTABLE for multi-processor boards
95h	Install CD ROM for boot
96h	Clear huge ES segment register
97h	Fix up Multi Processor table
98h	1-2 Search for option ROMs and shadow if successful. One long, two short beeps on checksum failure

POST Code	Description
99h	Check for SMART Drive (optional)
9Ch	Set up Power Management
9Dh	Initialize security engine (optional)
9Eh	Enable hardware interrupts
9Fh	Determine number of ATA and SCSI drives
A0h	Set time of day
A2h	Check key lock
A4h	Initialize typematic rate
A8h	Erase <ESC> prompt
AAh	Scan for <ESC> key stroke
ACh	Enter SETUP
A Eh	Clear Boot flag
B0h	Check for errors
B1h	Inform RomPilot about the end of POST (optional)
B2h	POST done - prepare to boot operating system
B4h	1 One short beep before boot
B5h	Terminate QuietBoot (optional)
B6h	Check password (optional)
B7h	Initialize ACPI BIOS and PPM Structures
B9h	Prepare Boot
BAh	Initialize SMBIOS
BCh	Clear parity checkers
BDh	Display MultiBoot menu
BEh	Clear screen (optional)
BFh	Check virus and backup reminders
C0h	Try to boot with INT 19
C1h	Initialize POST Error Manager (PEM)
C2h	Initialize error logging
C3h	Initialize error display function
C4h	Initialize system error flags
C6h	Console redirection init.
C7h	Unhook INT 10h if console redirection enabled
C8h	Force check (optional)
C9h	Extended ROM checksum (optional)
CDh	Reclaim console redirection vector

POST Code Description

D2h	Unknown interrupt
D4h	Check Intel Branding string
D8h	Alert Standard Format initialization
D9h	Late init for IPMI
DEh	Log error if micro-code not updated properly

The following are for boot block in Flash ROM**POST Code Description**

E0h	Initialize the chipset
E1h	Initialize the bridge
E2h	Initialize the CPU
E3h	Initialize system timer
E4h	Initialize system I/O
E5h	Check force recovery boot
E6h	Checksum BIOS ROM
E7h	Go to BIOS
E8h	Set Huge Segment
E9h	Initialize Multi Processor
EAh	Initialize OEM special code
EBh	Initialize PIC and DMA
ECh	Initialize Memory type
EDh	Initialize Memory size
EEh	Shadow Boot Block
EFh	System memory test
F0h	Initialize interrupt vectors
F1h	Initialize Run Time Clock
F2h	Initialize video
F3h	Initialize System Management Manager
F4h	Output one beep
F5h	Clear Huge Segment
F6h	Boot to Mini DOS
F7h	Boot to Full DOS

If the BIOS detects errors on 2C, 2E, or 30 (base 512K RAM error), it displays an additional word-bitmap (**xxxx**) indicating the address line or bits that have failed. For example, "2C 0002" means address line 1 (bit one set) has failed. "2E 1020" means data bits 12 and 5 (bits 12 and 5 set) have failed in the lower 16 bits. The BIOS also sends the bitmap to the port-80 LED display. It first displays the checkpoint code, followed by a delay, the high-order byte, another delay, and then the low-order byte of the error. It repeats this sequence continuously.

Notes

Appendix C

Intel HostRAID Setup Guidelines

After all the hardware has been installed, you must first configure Intel's ESB2 SATA RAID before you install the Operating System and other software drivers.

Important Notes to the User:

- If you do not wish to configure onboard SATA RAID functions, please go directly to Section C-2, Appendix D and Appendix E for Operating System & Other Software Installation.
- This chapter describes RAID Configuration Instructions for the Intel ESB2 RAID Controller designed for the Windows OS.

C-1 Introduction to Serial ATA and Parallel ATA

To configure the SATA RAID functions, you must first use the Intel ESB2 SATA RAID Utility program to configure the RAID Level that you desire before installing the Windows XP/2000/2003 operating system and other software drivers. (The necessary drivers are all included in the Supermicro CD that came with your motherboard.) The current version of the ESB2 SATA RAID Utility can only support the Windows XP/2000/2003 Operating Systems.

Serial ATA (SATA)

Serial ATA (SATA) is a physical storage interface that uses a single cable with a minimum of four wires to create a point-to-point connection between devices. It is a serial link, which supports transfer rates up to 3.0 Gbps. Because the serial cables used in SATA are thinner than the traditional cables used in Parallel ATA (PATA), SATA systems have better airflow and can be installed in smaller chassis than Parallel ATA. In addition, the cables used in PATA are limited to a length of 40cm, while Serial ATA cables can be up to one meter in length. Overall, SATA provides better functionality than PATA.

Introduction to the Intel ESB2 Serial RAID

Located in the South Bridge of the 5400 chipset, the I/O Controller Hub (ESB2) provides the I/O subsystem with access to the rest of the system. It supports a 1-channel UltraATA/100 Bus Master IDE controller (PATA) and six Serial ATA (SATA) ports. The ESB2 supports the following PATA and SATA device configurations: Legacy mode and Native mode.

The Intel HostRAID Configurations

The following types of Intel's HostRAID configurations are supported:

RAID 0 (Data Striping): this writes data in parallel, interleaved ("striped") sections of two hard drives. Data transfer rate is doubled over using a single disk.

RAID 1 (Data Mirroring): an identical data image from one drive is copied to another drive. The second drive must be the same size or larger than the first drive.

RAID 10 (Striping & Mirroring): RAID 0 and 1 schemes are combined (without parity information) to get the benefits of both.

RAID 5: both data and parity information are striped and mirrored across three or more hard drives.

The Intel Matrix Storage

The Intel Matrix Storage, supported by the ESB2, allows the user to create RAID 0, RAID 1, RAID 10 and RAID 5 sets by using only six identical hard disk drives. The Intel Matrix Storage Technology creates two partitions on each hard disk drive and generate a virtual RAID 0, RAID 1, RAID 10 and RAID 5 sets. It also allows you the change the HDD partition size without any data.

Configuring BIOS settings for SATA RAID Functions (Native Mode)

1. Press the key during system bootup to enter the BIOS Setup Utility.

Note: If it is the first time powering on the system, we recommend that you load the Optimized Default Settings. If you have already done so, please skip to Step 3.

2. Use the arrow keys to select the "Exit" Settings. Once in the "Exit" settings, Scroll down to select "Load Optimized Default Settings" and press the <Enter> key. Select "OK" to confirm the selection. Press the <Enter> key to load the default settings for the BIOS.

3. Use the arrow keys to select the "Main" section in the BIOS.

4. Scroll down to "SATA Controller Mode" and press the <Enter> key to select "Enhanced"

5. Scroll down to "SATA RAID Enabled" and press <Enter>. Then, select "Enabled."

6. Go to "Exit". Select "Exit Saving Changes" from the "Exit" menu. Press the <Enter> key to save the changes and exit the BIOS.

7. Once you've exited the BIOS Utility, the system will reboot.

8. During the system boot-up, press the <Ctrl> and <I> keys simultaneously to run the Intel RAID Configuration Utility when prompted by the following message:
Press <Ctrl> <I> for the Intel RAID Configuration Utility.

Note: The Intel RAID Configuration Utility is only available for systems with two or more drives installed. The Intel RAID Utility screen will not display in systems with one drive installed.

Using the Intel ESB2 SATA RAID Utility Program

1. Creating, Deleting and Resetting RAID Volumes:

- a. After the system exits from the BIOS Setup Utility, the system will automatically reboot. The following screen appears after Power-On Self Test.

```

RAID Volumes:
None defined.

Physical Disks:
Port Drive Model      Serial #              Size   Type/Status(Vol ID)
0   HDC WD2500SD-01K  WD-WMAL72034971      232.9GB Non-RAID Disk
1   HDC WD2500SD-01K  WD-WMAL72034599      232.9GB Non-RAID Disk
2   HDC WD2500JD-00F  WD-WMAEH1376109      232.9GB Non-RAID Disk
3   HDC WD2500JD-00F  WD-WMAEH1449527      232.9GB Non-RAID Disk

Press <CTRL-I> to enter Configuration Utility...

Adaptec SCSI BIOS v4.30.0
Copyright 2003 Adaptec, Inc. All Rights Reserved.

<<< Press <Ctrl><A> for SCSISelect(TM) Utility! >>>

Slot Ch ID LUN Vendor      Product              Size Bus Status
-----
04  A  10  0

```

- b. When you see the above screen, press the <Ctrl> and the <I> keys simultaneously to have the main menu of the SATA RAID Utility appear:

Note: All graphics and screen shots shown in the manual are for reference only. The screen shots shown in the manual do not imply Supernicro's endorsement or non-endorsement on any 3rd party's product. Your screens may or many not look exactly the same as the graphics shown in this manual.

Creating a RAID 0 Volume:

- a. Select "Create RAID Volume" from the main menu and press the <Enter> key. The following screen will appear:



- b. Specify a name for the RAID 0 set and press the <Tab> key or the <Enter> key to go to the next field. (You can use the <Esc> key to select the previous menu.)
- c. When RAID Level item is highlighted, press the <Up Arrow>, <Down Arrow> keys to select RAID 0 (Stripe) and hit <Enter>.
- d. When the Disks item is highlighted, press <Enter> to select the HDD to configure as RAID. The following pop-up screen (*See the note on Page C-3) displays:

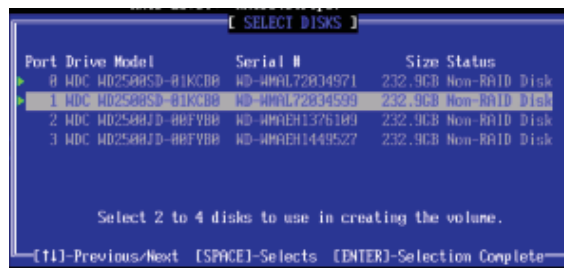

- e. Use the <Up Arrow>, <Down Arrow> keys to highlight a drive and press <Space> to select it. A triangle appears to confirm the selection of the drive.
- f. Use the <Up Arrow>, <Down Arrow> keys to select the stripe size, ranging from 4 KB to 128 KB for the RAID 0 array, and hit <Enter>. (**Note:** For a server, please use a lower stripe size, and for a multimedia system, use a higher stripe size. The default stripe size is 128 KB.)
- g. Press <Enter> when the Create Volume item is highlighted. A warning message displays.
- h. When asked "Are you sure you want to create this volume (Y/N), press "Y" to create the RAID volume, or type "N" to go back to the Create Volume menu.

Creating a RAID 1 Volume:

- a. Select "Create RAID Volume" from the main menu and press the <Enter> key. The following screen will appear:

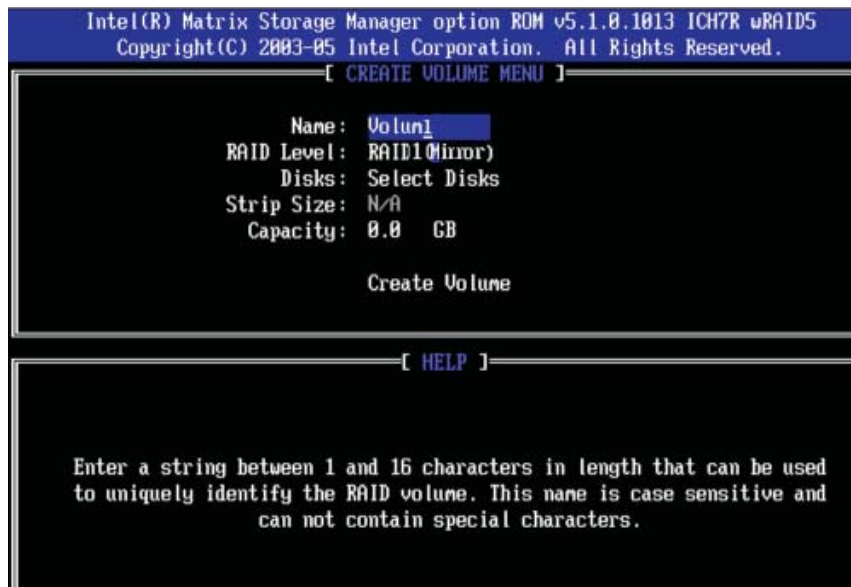

- b. Specify a name for the RAID 1 set and press the <Tab> key or the <Enter> key to go to the next field. (You can use the <Esc> key to select the previous menu.)
- c. When RAID Level item is highlighted, press the <Up Arrow>, <Down Arrow> keys to select RAID 1 (Mirror) and hit <Enter>.
- d. When the Capacity item is highlighted, enter your RAID volume capacity and hit <Enter>. The default setting is the maximum capacity allowed.
- e. Press <Enter> when the Create Volume item is highlighted. A warning message displays.
- f. When asked "Are you sure you want to create this volume (Y/N)", press "Y" to create the RAID volume, or type "N" to go back to the Create Volume menu.

Creating a RAID 10 (RAID 1+ RAID 0):

- a. Select "Create RAID Volume" from the main menu and press the <Enter> key. The following screen will appear:

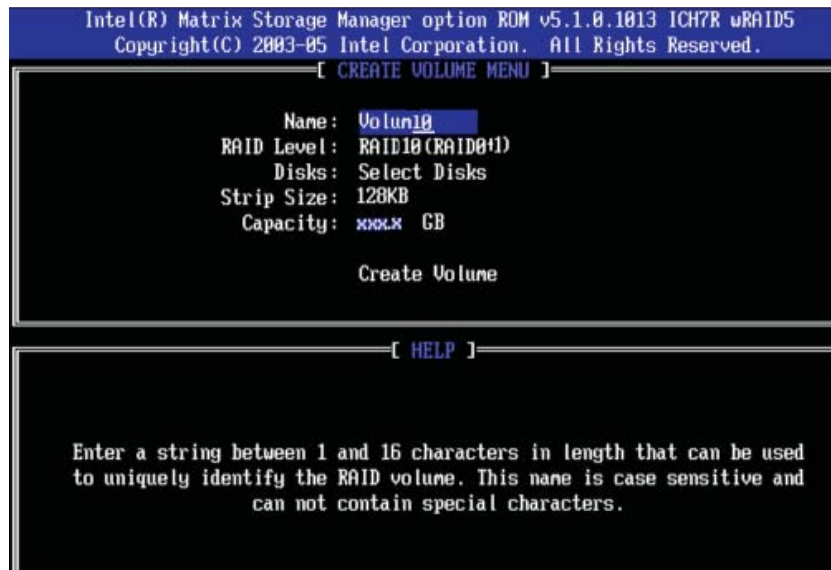

- b. Specify a name for the RAID 10 set and press <Enter>.
- c. When RAID Level item is highlighted, use the <Up Arrow>, <Down Arrow> keys to select RAID 10 (RAID1 + RAID0) and hit <Enter>.
- d. When the Stripe Size is highlighted, use the <Up Arrow>, <Down Arrow> keys to select the stripe size from 4 KB to 128 KB for your RAID 10 and hit <Enter>. The default setting is 64 KB. (Note: For a server, please use a lower stripe size, and for a multimedia system, use a higher stripe size.)
- e. When the RAID Volume Capacity item is highlighted, enter your RAID volume capacity and hit <Enter>. The default setting is the maximum capacity allowed.
- f. Press <Enter> when the Create Volume item is highlighted. A warning message displays.
- g. When asked "Are you sure you want to create this volume (Y/N)", press "Y" to create the RAID volume, or type "N" to go back to the Create Volume menu.

Creating a RAID 5 Set (Parity):

- a. Select "Create RAID Volume" from the main menu and press the <Enter> key. The following screen will appear:



- b. Specify a name for the RAID 5 set and press <Enter>.
- c. When the Raid Level is highlighted, use the <Up Arrow>, <Down Arrow> keys to select RAID 5 (Parity) and hit <Enter>.
- d. When the Disk item is highlighted, press <Enter> to select the HDD to configure as RAID. The following pop-up screen (*See the Note on Page C-3) displays:

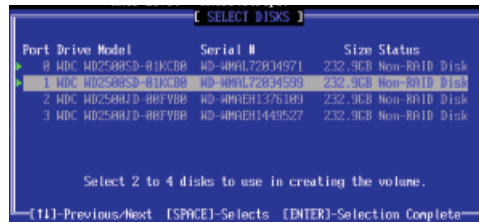

- e. Use the <Up Arrow>, <Down Arrow> keys to highlight a drive and press <Space> to select it. A triangle appears to confirm the selection of the drive.
- f. Use the <Up Arrow>, <Down Arrow> keys to select the stripe size, ranging from 4 KB to 128 KB for the RAID 5 array, and hit <Enter>. (**Note:** For a server, please use a lower stripe size, and for a multimedia system, use a higher stripe size. The default stripe size is 128 KB.)
- g. Enter your desired RAID volume capacity and press <Enter> when the capacity item is highlighted. The default setting is the maximum capacity allowed.
- h. Press Enter when the Create Volume item is highlighted. A warning message displays.
- i. When asked "Are you sure you want to create this volume (Y/N), press "Y" to create the RAID volume, or type "N" to go back to the Create Volume menu.

Deleting RAID Volume:



Warning: Be sure to back up your data before deleting a RAID set. You will lose all data on the disk drives when deleting a RAID set.

- a. From the main menu, select item2-Delete RAID Volume, and press <Enter>.
- b. Use the <Up Arrow>, <Down Arrow> keys to select the RAID set you want to delete and press . A Warning message displays.
- c. When asked "Are you sure you want to delete this volume (Y/N), press "Y" to delete the RAID volume, or type "N" to go back to the Delete Volume menu.

Resetting to Non-RAID and Resetting a RAID HDD

Warning: Be cautious when you reset a RAID volume HDD to non-RAID or Resetting a RAID HDD. Resetting a RAID volume HDD or Resetting a RAID HDD will reformat the HDD and delete the internal RAID structure on the drive.

- a. From the main menu, select item3-Reset Disks to Non- RAID, and press <Enter>. The following screen will appear:



- b. Use the <Up Arrow>, <Down Arrow> keys to highlight the RAID set drive to reset and press <Space> to select.
- c. Press <Enter> to reset the RAID set drive. A Warning message displays.
- d. Press "Y" to reset the drive, or type "N" to go back to the main menu.

Exiting the Intel Matrix Storage Manager Utility:

- a. From the main menu, select item4-Exit, and press <Enter>. A warning message will appear.
- b. Press "Y" to reset the drive, or type "N" to go back to the main menu.

C-2 Installing Windows XP/2000/2003 for RAID Systems

Installing a New Operating System-the Windows XP/2000/2003 OS

1. Insert the Microsoft Windows XP/2000/2003 Setup CD in the CD Driver, and the system will start booting up from CD.
2. Press the <F6> key when the message-" Press F6 if you need to install a third party SCSI or RAID driver" displays.
3. When the Windows XP/2000/2003 Setup screen appears, press "S" to specify additional device(s).
4. Insert the driver diskette-"Intel AA RAID XP/2000/2003 Driver for ESB2 into Drive A: and press the <Enter> key.
5. Choose the Intel(R) ESB2 SATA RAID Controller from the list indicated in the XP/2000/2003 Setup Screen, and press the <Enter> key.
6. Press the <Enter> key to continue the installation process. (If you need to specify any additional devices to be installed, do it at this time.) Once all devices are specified, press the <Enter> key to continue with the installation.
7. From the Windows XP/2000/2003 Setup screen, press the <Enter> key. The XP/2000/2003 Setup will automatically load all device files and then, continue the Windows XP/2000/2003 installation.
8. After the Windows XP/2000/2003 Installation is completed, the system will automatically reboot.

Note: the current version of the ESB2 SATA RAID Utility can only support the Windows XP/2000/2003 Operating System.

C-3 Installing Drivers other than the Adaptec Embedded Serial ATA RAID Controller Driver

After you've installed the Windows Operating System, a screen as shown below will appear. You are ready to install software programs and drivers that have not yet been installed. To install these software programs and drivers, click the icons to the right of these items.



Driver/Tool Installation Display Screen

Note: Click the icons showing a hand writing on the paper to view the readme files for each item. Click on a computer icon to the right of an item to install an item (from top to the bottom) one at a time. **After installing each item, you must re-boot the system before proceeding with the next item on the list.** The bottom icon with a CD on it allows you to view the entire contents of the CD.

C-4 Configuring Supero Doctor III

The Supero Doctor III program is a Web-base management tool that supports remote management capability. It includes Remote and Local Management tools. The local management is called the SD III Client. The Supero Doctor III program included on the CDROM that came with your motherboard allows you to monitor the environment and operations of your system. Supero Doctor III displays crucial system information such as CPU temperature, system voltages and fan status. See the Figure below for a display of the Supero Doctor III interface.

The default user name and password are ADMIN.

In the Windows OS environment, the Supero Doctor III settings take precedence over the BIOS settings. When first installed, Supero Doctor III adopts the temperature threshold settings previously set in BIOS. Any subsequent changes to these thresholds must be made within Supero Doctor, since the SD III settings override the BIOS settings. For the Windows OS to adopt the BIOS temperature threshold settings, please change the SDIII settings to be the same as those set in BIOS.

Supero Doctor III Interface Display Screen-I (Health Information)



Supero Doctor III Interface Display Screen-II (Remote Control)



Note: SD III Software Revision 1.0 can be downloaded from our Web site at: ftp://ftp.supermicro.com/utility/Supero_Doctor_III/. You can also download SDIII User's Guide at: <http://www.supermicro.com/PRODUCT/Manuals/SDIII/User-Guide.pdf>. For Linux, we will still recommend that you use Supero Doctor II.

Notes

Appendix D

Adaptec HostRAID Setup Guidelines

After all the hardware has been installed, you must first configure the Adaptec Embedded Serial ATA RAID before you install the Windows operating system. The necessary drivers are all included on the Supermicro bootable CDs that came packaged with your motherboard. Note: *The following section provides information on the Adaptec SATA RAID Driver based on the Intel Enterprise South Bridge 2 (ESB2) Controller.*

D-1 Introduction to the Adaptec SATA RAID Controller

Serial ATA (SATA)

SATA is a physical storage interface that uses a single cable with a minimum of four wires to create a point-to-point connection between devices. It is a serial link which supports transfer rates up to 3.0 Gbps. Because the serial cables used in SATA are thinner than the traditional cables used in Parallel ATA (PATA), SATA systems have better airflow and can be installed in smaller chassis. In addition, the cables used in PATA can only extend to 40cm long, while SATA cables can extend up to one meter. Overall, SATA provides better functionality than PATA.

ESB2 I/O Controller Hub

Located in the South Bridge of the Intel 5400 chipset, the ESB2 I/O Controller Hub provides the I/O subsystem with access to the rest of the system. It supports a 1-channel Ultra ATA/100 Bus Master IDE controller and an Adaptec SATA Host Controller, which support up to six SATA drives, up to two RAID volumes and up to four drives in RAID configurations. See the table below for details.

* Adaptec's SATA HostRAID Controller Firmware supports:	
Drives supported	Six
Number of RAID Volumes supported	Two
Total Drives in RAID Configurations	Four
Examples of Valid RAID Configurations:	
Two drives of RAID 1 + two drives of RAID 0	
Two drives of RAID 1 + two drives of RAID 1	
Three drives of RAID 0	
Four drives of RAID 0	
Examples of Invalid RAID Configurations:	
Three drives of RAID 0 + two drives of RAID 1	
(*Note: this table is applicable to Adaptec's HostRAID Controller Firmware only.)	

Configuring Adaptec SATA RAID for supported Operating Systems

1. Press the key during system bootup to enter the BIOS Setup Utility.

Note: If it is the first time powering on the system, we recommend you load the Optimized Default Settings. If you have already done so, please skip to Step 3.

2. Use the arrow keys to select the "Exit" Settings. Once in the "Exit" settings, Scroll down to select "Load Optimized Default Settings" and press the <Enter> key. Select "OK" to confirm the selection. Press the <Enter> key to load the default settings for the BIOS.

3. Use the arrow keys to select the "Main" section in BIOS.

4. Scroll down to "SATA Control Mode" and press the <Enter> key to select "Enhanced"

5. Scroll down to "SATA RAID Enabled" and press <Enter>. Then, select "Enabled."

6. Scroll down to "ICH RAID Codebase" and select "Adaptec". Then press <Enter>. (For ICH RAID Codebase: Change the setting from Intel to Adaptec.)

7. Go to "Exit". Select "Exit Saving Changes" from the "Exit" menu. Press the <Enter> key to save the changes and exit the BIOS.

8. Once you've exited the BIOS Utility, the system will re-boot.

9. During the system boot-up, press the <Ctrl> and <A> keys simultaneously to run the Intel RAID Configuration Utility when prompted by the following message: Press <Ctrl> <A> for Intel RAID Configuration Utility.

Adaptec SATA with HostRAID Controller Driver

The Adaptec Embedded Serial ATA RAID Controller adds SATA/RAID functionality and performance enhancements to a motherboard. RAID striping (RAID 0) allows data to be written across multiple drives, greatly improving hard disk I/O performance. RAID mirroring (RAID 1) allows data to be simultaneously written to two drives, improving data security even if a single hard disk fails. A Stripe of Mirrors (RAID 10) provides multiple RAID 1 mirrors and a RAID 0 stripe, maximizing data security and system efficiency. By incorporating the Adaptec Embedded Serial ATA into the motherboard design, Supermicro's X7DWN+ offers the user the benefits of SATARAID without the high costs associated with hardware RAID applications.

Using the Adaptec RAID Configuration Utility (ARC)

The Adaptec RAID Configuration Utility, an embedded BIOS Utility, includes the following:

Array Configuration Utility: Use this utility to create, configure and manage arrays.

Disk Utilities: Use this option to format or verify disks.

To run the Adaptec RAID Configuration Utility, you will need to do the following:

1. Enable RAID functions in the system BIOS (refer to Chapter 4 for System BIOS Configurations).
2. Press the <Ctrl> and <A> keys simultaneously when prompted to do so during system boot. (Refer to the previous page for detailed instructions.)

A. Using the Array Configuration Utility (ACU)

When you press <Ctrl> and <A> keys simultaneously at the prompt during system bootup, the main menu will appear.

Note: To select an option, use the arrow keys to highlight the item and then press the <Enter> key to select it. To return to the previous menu, press the <ESC> key. Press the <Insert> key to select a drive. When a drive is highlighted (selected), press the <Delete> key to de-select it.

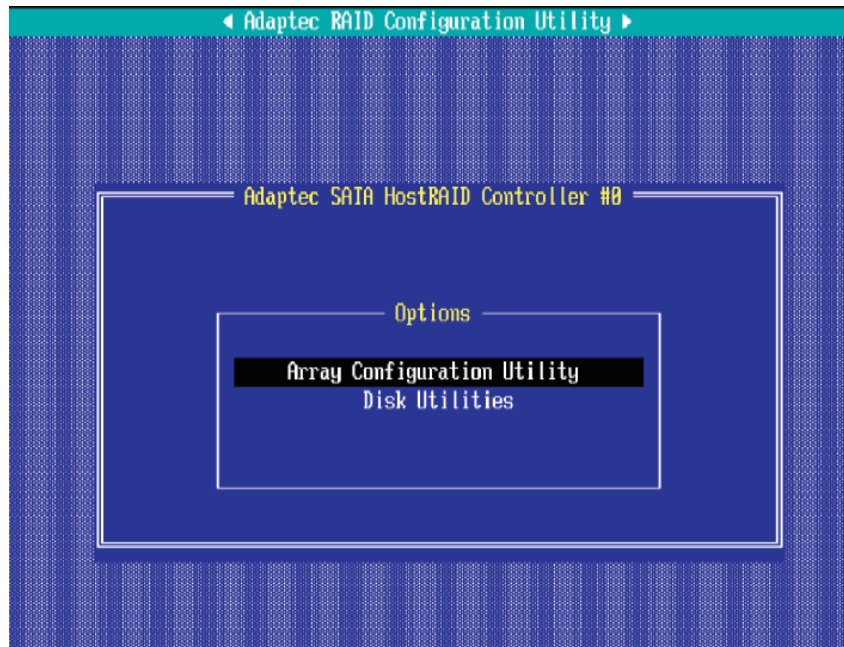

Managing Arrays

Select this option to view array properties, and configure array settings.

To select this option, using the arrow keys and the <enter> key, select "Managing Arrays" from the main menu as shown above.

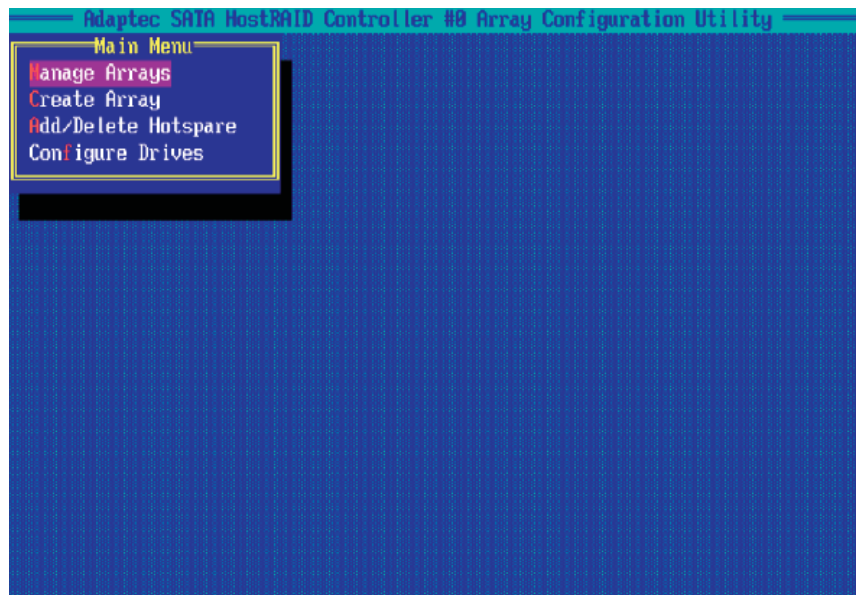

Configuring Disk Drives

You may need to configure a disk drive before you can use it.

Caution: Configuring a disk may overwrite the partition table on the disk and may make any data on the disk inaccessible. If the drive is used in an array, you may not be able to use the array again.

Do not configure a disk that is part of a boot array. To determine which disks are associated with a particular array, please refer to [Viewing Array Properties](#).

To configure a disk drive:

1. From the main menu (shown on Page D-4), select Configure Drives and hit <Enter> (as shown below.)



2. From the "Select Drives for Configuring" List (shown below,) select the drives you want to configure and press <Insert>.

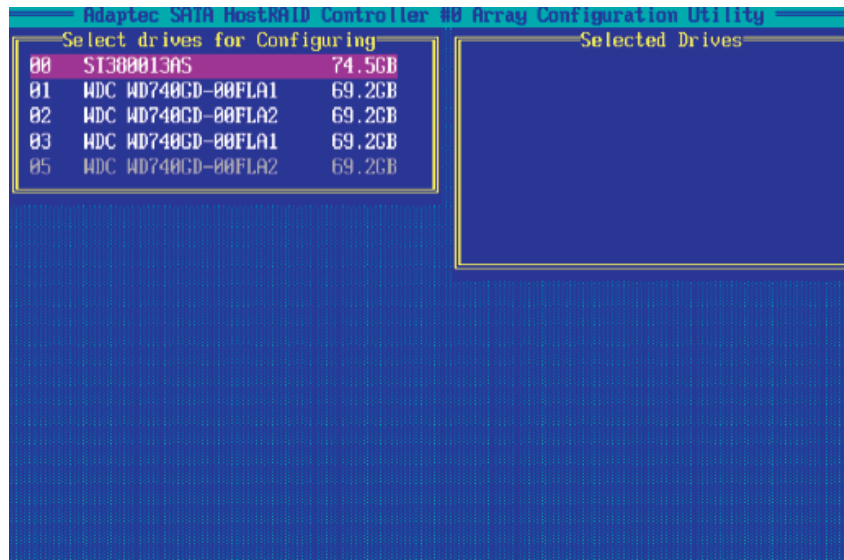

3. The drive you've selected will appear in the "Selected Drives Dialog Box" on the right (as shown below.) Repeat the same steps until all drives that you want to configure appear in the selected drives box.

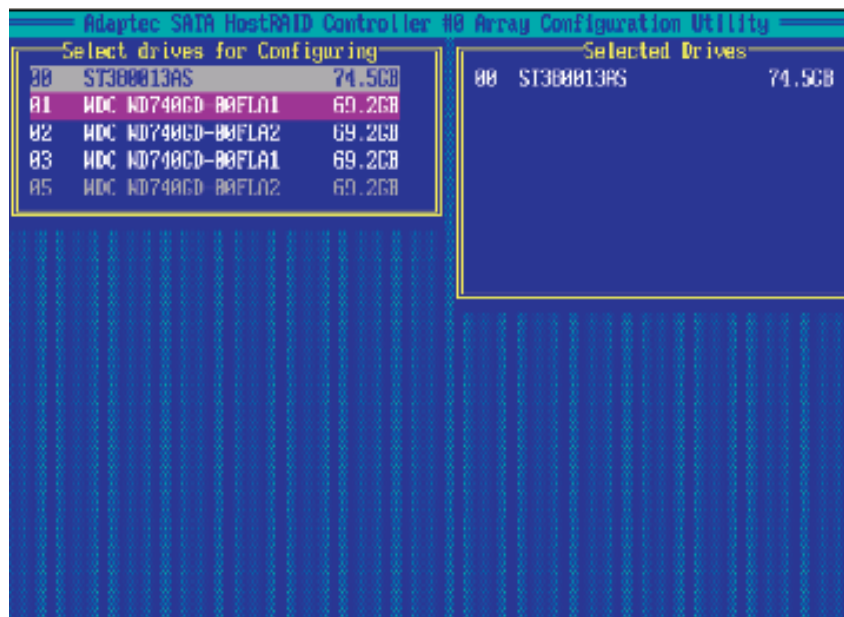

4. Once both drives display in the selected drive box, press <Enter.>

5. Read the warning message as shown in the screen below.

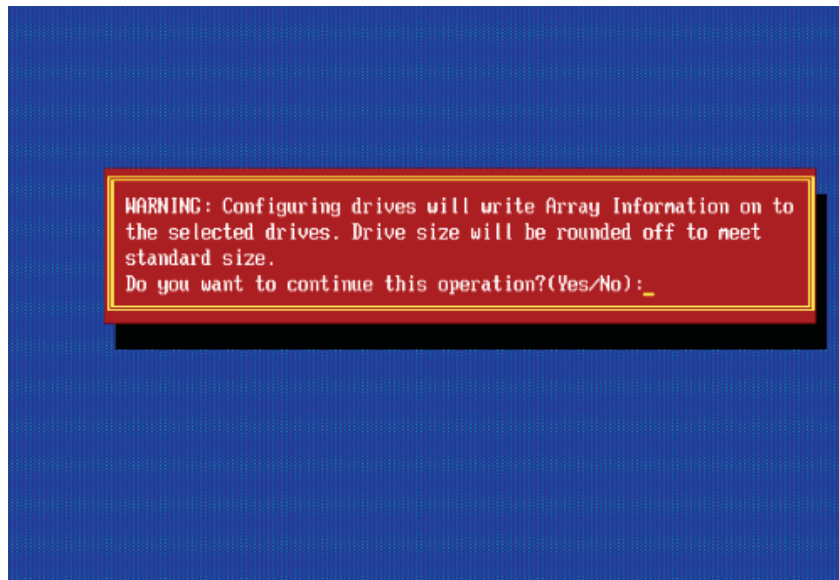

6. Make sure that you have selected the correct disk drives to configure. If correct, type Y to continue.

Creating Arrays

Before you create arrays, make sure that the disks for the array are connected and installed in your system. Note that disks with no usable space, or disks that are un-initialized or not formatted are shown in gray and cannot be used. (**Note:** It is recommended that you configure devices before you create arrays.)

To create an array:

1. From the main menu (shown on page D-4), select Create Array.
2. Select the disks for the new array and press Insert (as the screen shown below).

Note: To de-select any disk, highlight the disk and press Delete.

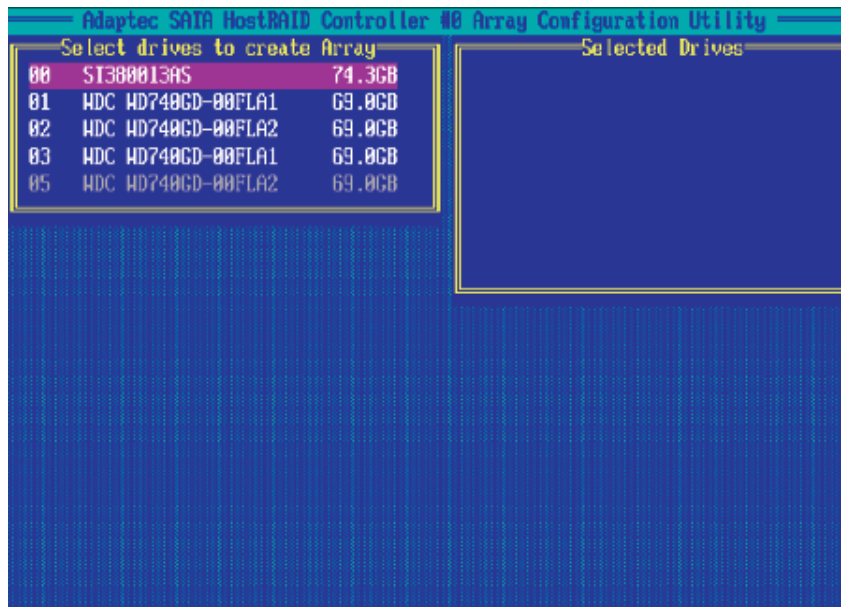

3. The arrays you have selected will appear on the Selected Drives dialog box on the right (as shown below.)

- 4 Press Enter when both disks for the new array are selected. The Array Properties menu displays.

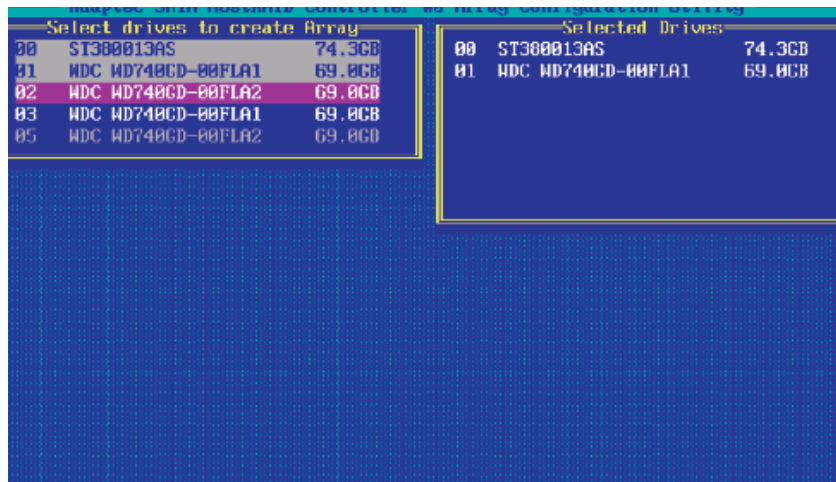

Assigning Array Properties

Once a new array is completed, you can assign properties to the array.

Caution: Once the array is created and its properties are assigned, and you cannot change the array properties using this utility.

To assign properties to the new array:

1. In the Array Properties menu (as shown in the screen below), select an array type and press Enter. Only the available array types will be displayed on the screen. (RAID 0 or RAID 1 requires two drives.)

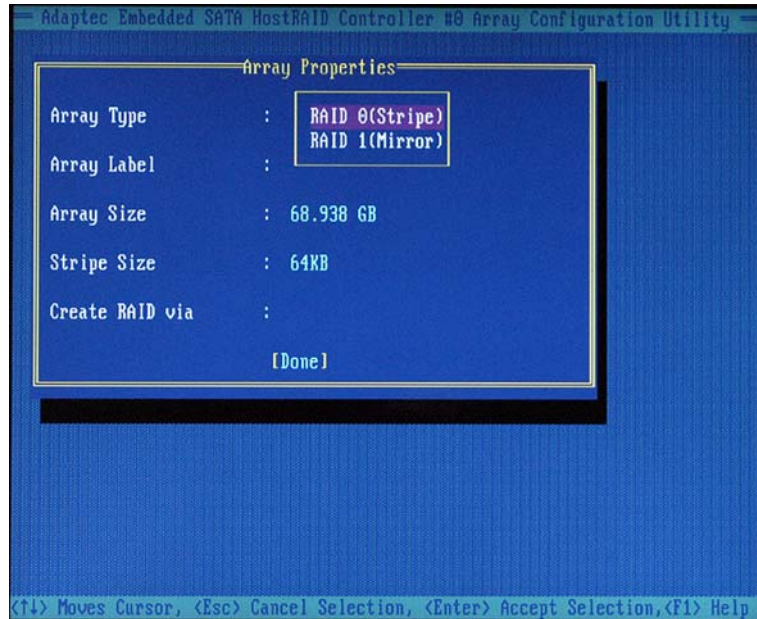

2. Under the item "Arrays Label", type in a label and press <Enter>. (Note: The label shall not be more than 15 characters.)
3. For RAID 0, select the desired stripe size. (**Note:** Available stripe sizes are 16, 32, and 64 KB. 64K is default. Please do not change the default setting.)
4. The item: "Create RAID via" allows you to select between the different ways of creating methods for RAID 0 and RAID 1.

The following table gives examples of when each is appropriate.

Raid Level	Create Via	When Appropriate
RAID 0	Quick Init	Creating a RAID 0 on new drives
RAID 0	Migrate*	Creating a RAID 0 from one new drive and one drive with data you wish to preserve
RAID 1	Build*	Any time you wish to create a RAID 1, but especially if you have data on one drive that you wish to preserve
RAID 1, RAID 10	Clear	Creating a RAID 1 or RAID 10 on new drives, or when you want to ensure that the array contains no data after creation.
RAID 1, RAID 10	Quick Init	Fastest way to create a RAID 1 or RAID 10 Appropriate when using new drives

Note: If you select Migrate for RAID 0, or Build for RAID 1, you will be asked to select the source drive. The contents of the source drive will be preserved. However, the data on the new drive will be lost.

5. When you are finished, press <Done> (as the screen shown below).

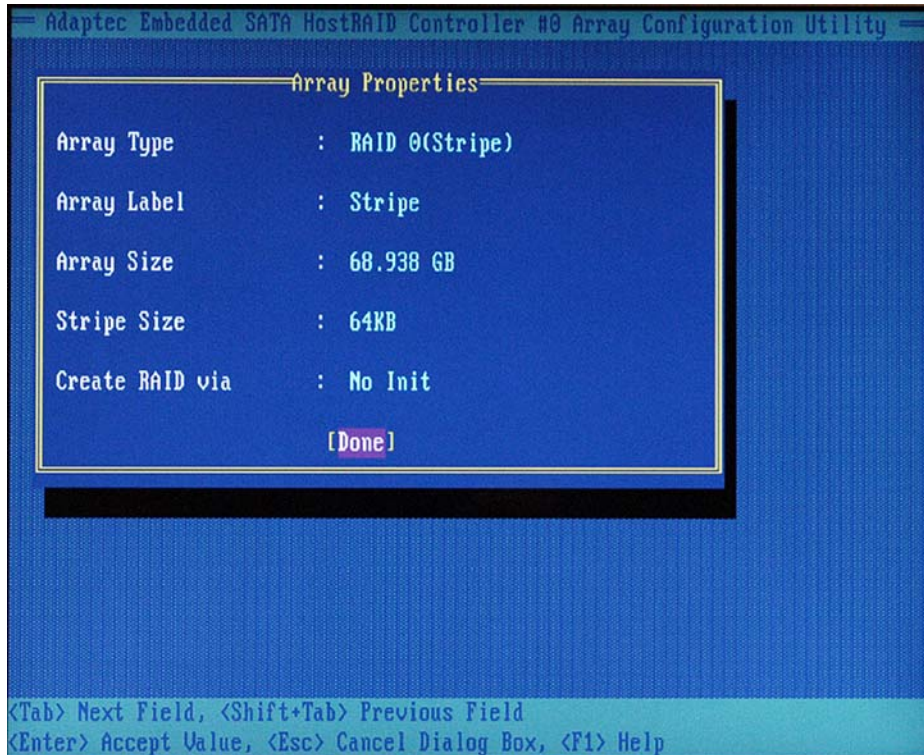

Notes:

1. Before adding a new drive to an array, be sure to back up any data stored on the new drive; otherwise, all data will be lost.
2. If you stop the Build or Clear process on a RAID 1, you can restart it by pressing <Ctrl> and <R>.
3. If you've used the Quick Init option to create a RAID1, it may return some data mis-comparison when you run a consistency check at a later time. This is normal.
4. The Adaptec Host RAID allows you to use drives of different sizes in a RAID. However, you can only select a smaller drive as the source or first drive during a build operation.
5. When migrating from single volume to RAID 0, migrating from a larger drive to a smaller drive is allowed. However, the destination drive must be at least half the capacity of the source drive.
6. It is not recommended that you migrate or build an array on Windows dynamic disks (volumes) because it will result in data loss.

Warning: Do not interrupt the process when you create a RAID 0 using the Migrate option. If you do, you will not be able to restart the system, or to recover the data that was on the source drive.

Adding a Bootable Array

To make an array bootable:

1. From the Main menu, select Manage Arrays.
2. From the List of Arrays, select the array you want to make bootable, and press <Ctrl> and .
3. Enter Y to create a bootable array when the following message is displayed: "This will make all other existing bootable array non-bootable. Do you want to make this array bootable? (Yes/No):" Then, a bootable array will be created. An asterisk (*) will appear next to the bootable array (as shown in the picture below:)



Deleting a Bootable Array

To delete a bootable array:

1. From the Main menu, select Manage Arrays.
2. From the List of Arrays, select the bootable array you want to delete, and press <Ctrl> and . Note: a bootable array is the array marked with an asterisk (as shown in the picture above.)
3. When the following message is displayed: "The array is already marked bootable. Do you want to make this array as not bootable? (Yes/No)," Enter Y to delete a bootable array. The bootable array will be deleted and the asterisk will disappear.

Note: Do not use the delete key to delete the bootable array.

Adding/Deleting Hotspares

To add a Hotspare:

Note: In order to rebuild a RAID (RAID 0 or RAID 1), you would need to add a new HDD as a hotspare.

1. From the main menu (shown on Page D-4), select Add/Delete Hotspares.
2. Use the up and down arrow keys to highlight and select the disk you want to designate as a hotspare, and press <Insert>, and then, press <Enter>.
3. Press Yes when the following prompt is displayed:

"Do you want to create spare?" (Yes/No?)

The spare you have selected will appear in the Selected drives Menu.

To delete a Hotspare:

1. From the main menu (shown on Page D-4), select Add/Delete Hotspares.
2. Use the up and down arrow keys to highlight and select the Hotspare you want to delete, and press <delete>, and then, press <Enter>.
3. When the following warning is displayed: "Do you want to delete the hot spare?" (Yes/No?), press Yes to delete the hotspare you have selected.

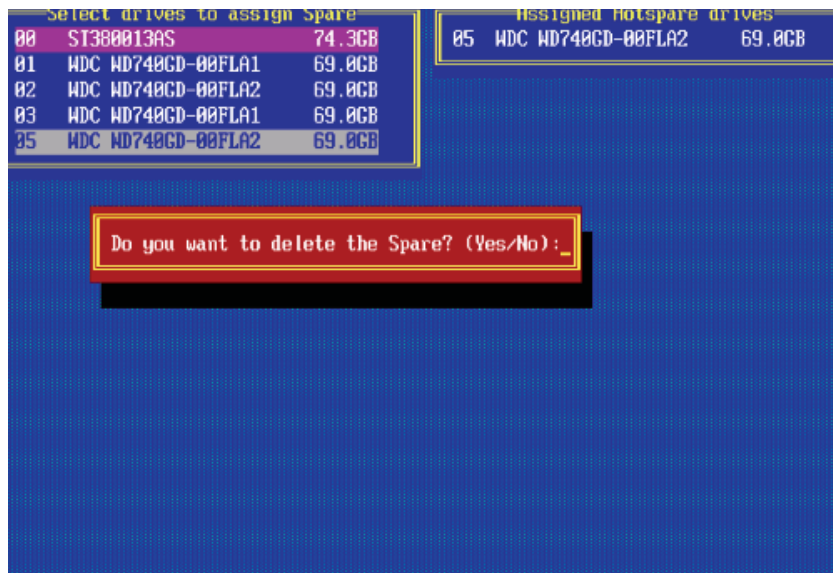

Viewing Array Properties

To view the properties of an existing array:

1. From the main menu, select Manage Arrays and hit <Enter> (as shown on the previous page.)
2. From the List of Arrays dialog box (shown below), select the array you want to view and press Enter.

The Array Properties dialog box appears (as shown below), showing detailed information on the array. The physical disks associated with the array are displayed here.

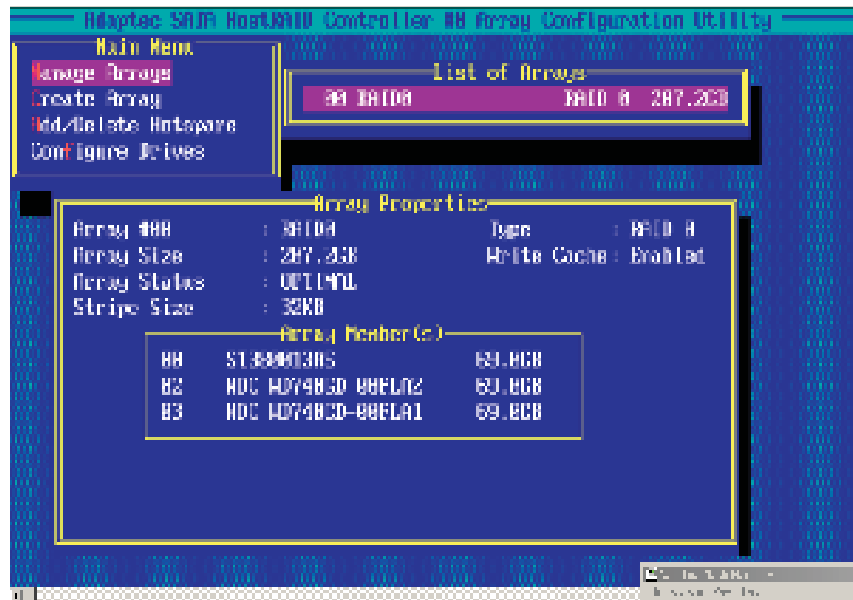

3. Press Esc to return to the previous menu.

Rebuilding Arrays

Note 1: Rebuilding applies to Fault Tolerant array (RAID 1) only.

If an array Build process is interrupted or when one critical member is missing, you must perform a Rebuild to restore its functionality. For a critical array rebuild operation, the optimal drive is the source drive.

Note 2: If no spare array exists and a hard disk drive fails, you need to create a spare before you can rebuild an array.

To Rebuild an array:

1 From the Main Menu, select Manage Arrays (as shown in the screen below). From the List of Arrays, select the array you want to Rebuild.

2 Press <Ctrl> and <R> to Rebuild.

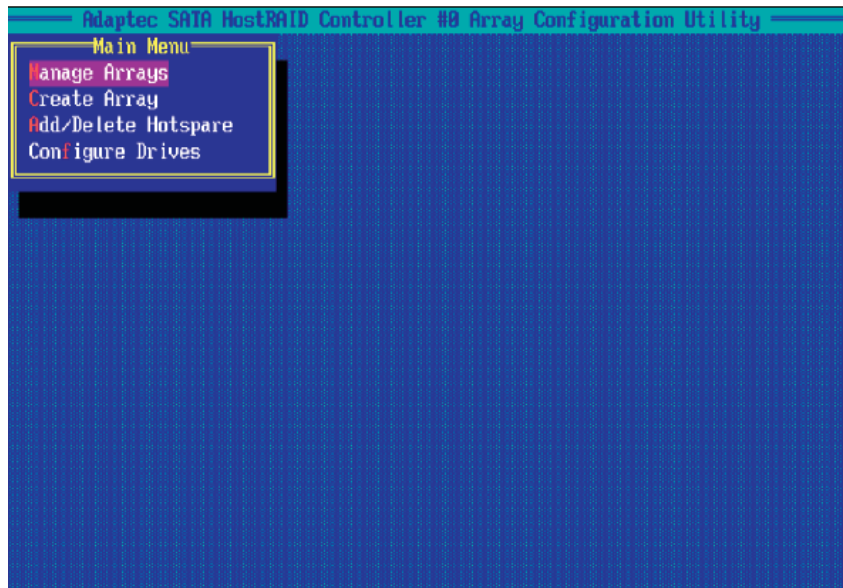

Deleting Arrays

Warning: Back up the data on an array before you delete it to prevent data loss. Deleted arrays cannot be restored.

To delete an existing array:

1. From the main menu (shown on Page D-4), select Manage Arrays.
2. Select the array you wish to delete and press <delete>.
3. In the Array Properties dialog box, select Delete and press <Enter>. The following prompt is displayed:

Warning!! Deleting the array will render array unusable. Do you want to delete the array? (Yes/No):

RAID 1 only—the following prompt is also displayed:

Deleting the partition will result in data loss! Do you also want to delete the partition? (Yes/No):

4. Press Yes to delete the array and partition or No to return to the previous menu.
5. Press Esc to return to the previous menu.

Using the Disk Utilities

The Disk Utilities enable you to format or verify the media of your Serial ATA hard disks.

To access the disk utilities:



1. From the Adaptec RAID Configuration Utility Menu, select Disk Utilities (as shown above) and press <Enter>. The following screen appears.

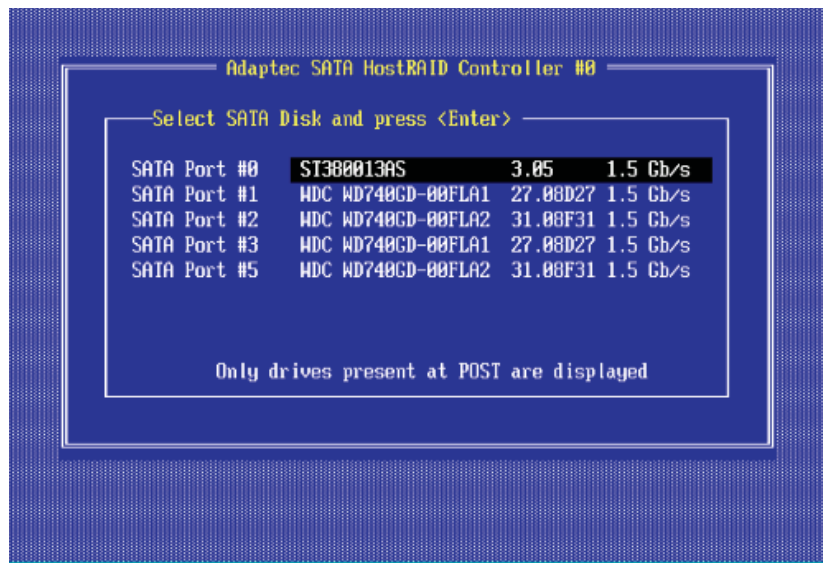

2. Select the desired disk and press <Enter>. The following screen appears:

To format a disk:

Note: The operation of Formatting Disk allows you to perform a low-level formatting of a hard drive by writing zeros to the entire disk. Serial ATA drives are low-level formatted at the factory and do not need to be low-level formatted again.

3. When the screen shown below displays, select Format Disk and press <Enter>. The following screen appears:

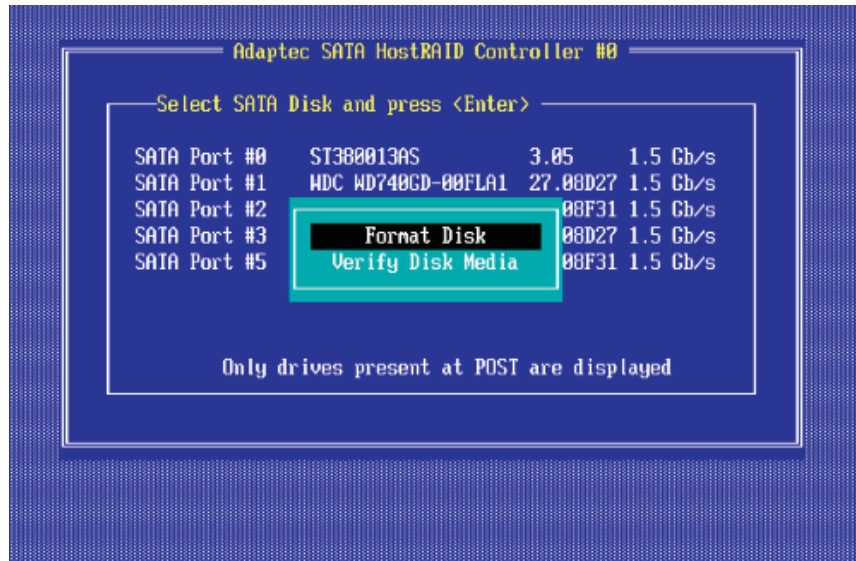

4. Read the warning message when it appears in the screen as shown below. To continue with disk formatting, select Yes and hit <Enter>. Otherwise, select No and press <Enter>.

Caution: Formatting a disk destroys all data on the drive. Be sure to back up your data before formatting a disk.

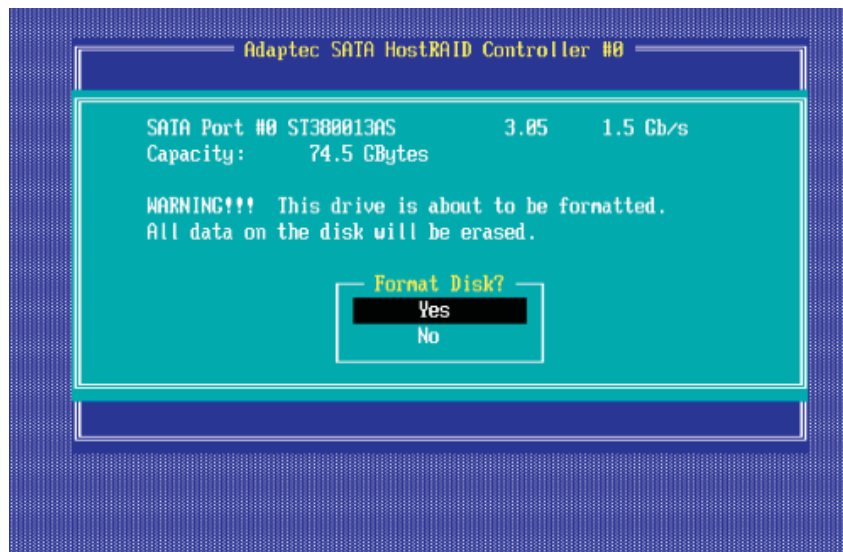

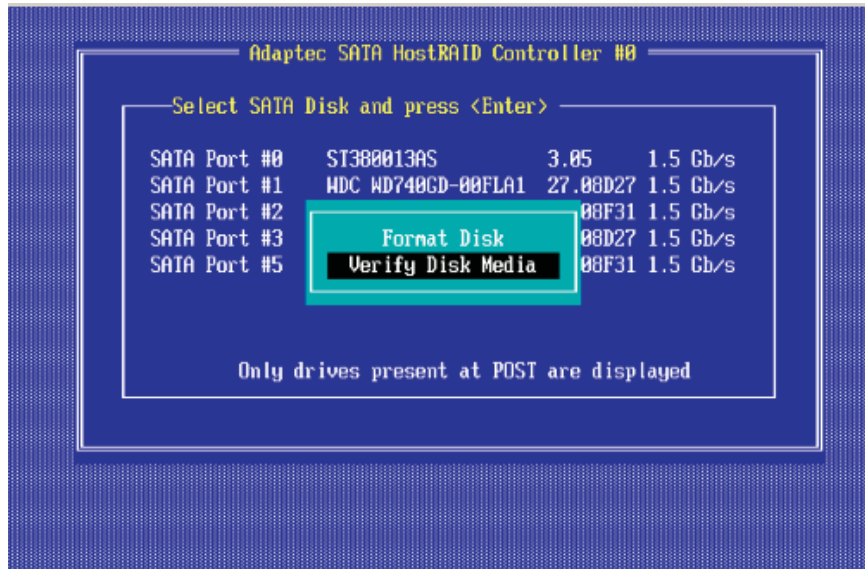
To verify disk media:

3. When the screen shown above displays, select Verify Disk Media and press <Enter>.

4. A message will display, indicating that the selected drive will be scanned for media defects. Select Yes and hit <Enter> to proceed with disk verifying; otherwise, select No and hit <Enter>.

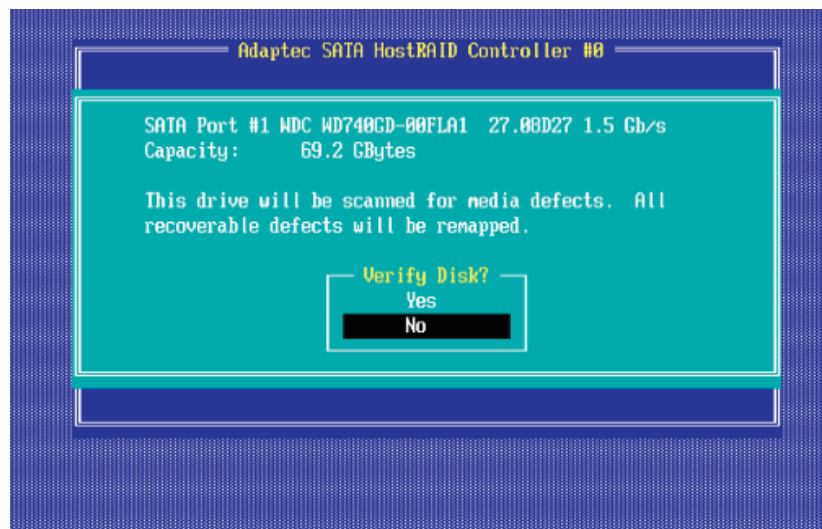

To Exit Adaptec RAID Configuration Utility

1. Once you have completed RAID array configurations, press ESC to exit. The following screen will appear.
2. Press Yes to exit the Utility.

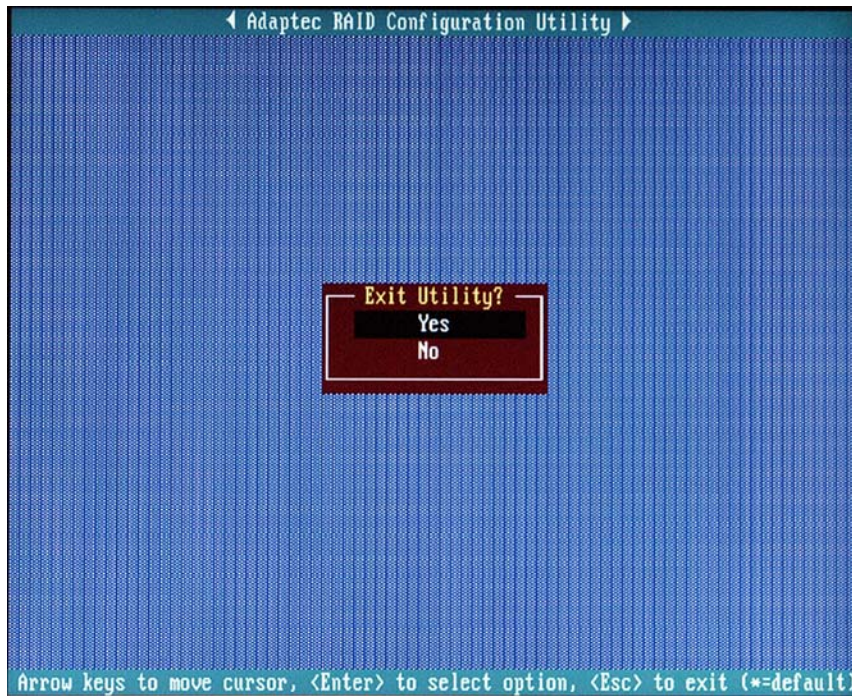

D-2 Installing Intel's ESB2 Driver by Adaptec and the OS

1. Insert Supermicro's bootable CD that came with the package into the CD Drive during the system reboot, and the screen: "Super Micro Driver Diskette Maker" will appear.
2. Choose from the list the item: "Intel ESB2 Driver by 3rd Party (Adaptec)" and press <ENTER>.
3. From the next screen displayed, choose the OS driver you want to install and press <Enter>.
4. Insert a formatted diskette into drive A: and press <Enter> as prompted.
5. Exit the program after the process is completed. Then, reboot the system.
6. Insert the Microsoft Windows OS Setup CD in the CD Driver, and the system will start to boot up from CD.
7. Press the <F6> key when the message-"Press F6 if you need to install a third party SCSI or RAID driver" displays.
8. When the Windows OS Setup screen appears, press "S" to specify additional device(s).
9. Insert the driver diskette-"Adaptec Embedded Serial ATA Raid Controller Driver" into Drive A: and press the <Enter> key.
10. Choose the Adaptec Embedded Host Serial ATA Raid Controller from the list indicated in the Windows OS Setup Screen, and press the <Enter> key.
11. Press the <Enter> key to continue the installation process. (If you need to specify any additional devices to be installed, do it at this time.) Once all devices are specified, press the <Enter> key to continue with the installation.
12. From the Windows OS Setup screen, press <Enter>. The OS Setup will automatically load all device files, and, then, continue with the Windows OS installation.
13. After the Windows OS Installation is completed, the system will automatically reboot.

Appendix E

System Specifications

Processors

Single or dual Intel® Xeon® LGA771 5400/5300LV or 5200/5100LV Sequence type processors at a front side (system) bus speed of 1600/1333/1066 MHz (both CPUs must be of the same type)

Note: Please refer to our web site for a complete listing of supported processors.

Chipset

Intel 5400/ESB2 chipset

BIOS

8 Mb Phoenix® Flash ROM

Memory Capacity

Sixteen 240-pin DIMM sockets supporting up to 128 GB of FBD ECC DDR2-800/667/533 SDRAM (Both 1.5V and 1.8V memory are supported.)

Note: Interleaved memory - requires memory must be installed four modules at a time. See Section 5-6 for details. DDR2-800 runs at 667 MHz with non-1600 MHz FSB CPUs.

SATA Controller

Intel on-chip (ESB2) controller for 6-port 3 Gb/s SATA (RAID 0, 1 supported)

SATA Drive Bays

Eight hot-swap drive bays to house six (6) standard SATA drives

Peripheral Drive Bays

One slim DVD-ROM drive

Expansion Slots

Three PCI-Express x8 slots, one PCI-Express x4 slot (in a x8 slot), two 64-bit 133/100 MHz PCI-X slots and one UIO slot. Two of the PCI-Express x8 slots are Gen 2.

Serverboard

X7DWN+ (Extended ATX form factor)

Dimensions: 13.68 x 13.05 in (348 x 332 mm)

Chassis

SC825TQ-R700LP, 2U rackmount

Dimensions: (WxHxD) 16.8 x 3.5 x 25.5 in. (427 x 89 x 648 mm)

Weight

Gross (Bare Bone): 57 lbs. (25.9 kg.)

System Cooling

Three (3) 8-cm system cooling fans

System Input Requirements

AC Input Voltage: 100-240V AC auto-range

Rated Input Current: 9.5A - 4.5A

Rated Input Frequency: 50 to 60 Hz

Power Supply

Rated Output Power: 700W (Part# PWS-702A-1R)

Rated Output Voltages: +12V (58A), +5Vsb (4A)

BTU Rating

3431 BTUs/hr (for rated output power of 700W)

Operating Environment

Operating Temperature: 10° to 35° C (50° to 95° F)

Non-operating Temperature: -40° to 70° C (-40° to 158° F)

Operating Relative Humidity: 8% to 90% (non-condensing)

Non-operating Relative Humidity: 5 to 95% (non-condensing)

Regulatory Compliance

Electromagnetic Emissions:

FCC Class A, EN 55022 Class A, EN 61000-3-2/-3-3, CISPR 22 Class A

Electromagnetic Immunity:

EN 55024/CISPR 24, (EN 61000-4-2, EN 61000-4-3, EN 61000-4-4,

EN 61000-4-5, EN 61000-4-6, EN 61000-4-8, EN 61000-4-11)

Safety:

EN 60950/IEC 60950-Compliant, UL Listed (USA), CUL Listed (Canada), TUV Certified (Germany), CE Marking (Europe)

California Best Management Practices Regulations for Perchlorate Materials:
This Perchlorate warning applies only to products containing CR (Manganese Dioxide) Lithium coin cells. "Perchlorate Material-special handling may apply. See www.dtsc.ca.gov/hazardouswaste/perchlorate"

(continued from front)

The products sold by Supermicro are not intended for and will not be used in life support systems, medical equipment, nuclear facilities or systems, aircraft, aircraft devices, aircraft/emergency communication devices or other critical systems whose failure to perform be reasonably expected to result in significant injury or loss of life or catastrophic property damage. Accordingly, Supermicro disclaims any and all liability, and should buyer use or sell such products for use in such ultra-hazardous applications, it does so entirely at its own risk. Furthermore, buyer agrees to fully indemnify, defend and hold Supermicro harmless for and against any and all claims, demands, actions, litigation, and proceedings of any kind arising out of or related to such ultra-hazardous use or sale.