

SUPERO®

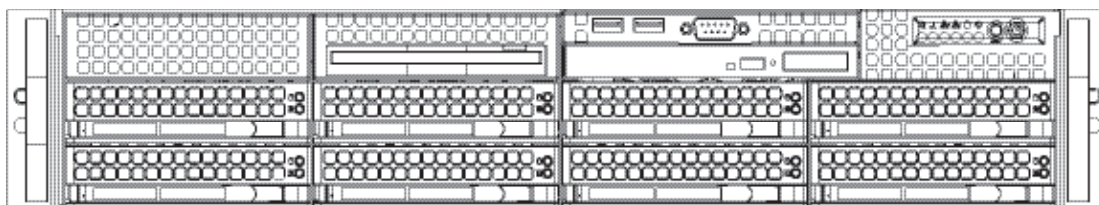

AS2021M-T2R+
AS2021M-82R+

USER'S MANUAL

1.0a

The information in this User's Manual has been carefully reviewed and is believed to be accurate. The vendor assumes no responsibility for any inaccuracies that may be contained in this document, makes no commitment to update or to keep current the information in this manual, or to notify any person or organization of the updates. **Please Note: For the most up-to-date version of this manual, please see our web site at www.supermicro.com.**

Super Micro Computer, Inc. ("Supermicro") reserves the right to make changes to the product described in this manual at any time and without notice. This product, including software, if any, and documentation may not, in whole or in part, be copied, photocopied, reproduced, translated or reduced to any medium or machine without prior written consent.

IN NO EVENT WILL SUPERMICRO BE LIABLE FOR DIRECT, INDIRECT, SPECIAL, INCIDENTAL, SPECULATIVE OR CONSEQUENTIAL DAMAGES ARISING FROM THE USE OR INABILITY TO USE THIS PRODUCT OR DOCUMENTATION, EVEN IF ADVISED OF THE POSSIBILITY OF SUCH DAMAGES. IN PARTICULAR, SUPERMICRO SHALL NOT HAVE LIABILITY FOR ANY HARDWARE, SOFTWARE, OR DATA STORED OR USED WITH THE PRODUCT, INCLUDING THE COSTS OF REPAIRING, REPLACING, INTEGRATING, INSTALLING OR RECOVERING SUCH HARDWARE, SOFTWARE, OR DATA.

Any disputes arising between manufacturer and customer shall be governed by the laws of Santa Clara County in the State of California, USA. The State of California, County of Santa Clara shall be the exclusive venue for the resolution of any such disputes. Super Micro's total liability for all claims will not exceed the price paid for the hardware product.

FCC Statement: This equipment has been tested and found to comply with the limits for a Class A digital device pursuant to Part 15 of the FCC Rules. These limits are designed to provide reasonable protection against harmful interference when the equipment is operated in a commercial environment. This equipment generates, uses, and can radiate radio frequency energy and, if not installed and used in accordance with the manufacturer's instruction manual, may cause harmful interference with radio communications. Operation of this equipment in a residential area is likely to cause harmful interference, in which case you will be required to correct the interference at your own expense.

California Best Management Practices Regulations for Perchlorate Materials: This Perchlorate warning applies only to products containing CR (Manganese Dioxide) Lithium coin cells. "Perchlorate Material-special handling may apply. See www.dtsc.ca.gov/hazardouswaste/perchlorate"

WARNING: Handling of lead solder materials used in this product may expose you to lead, a chemical known to the State of California to cause birth defects and other reproductive harm.

Manual Revision 1.0a
Release Date: January 13, 2009

Unless you request and receive written permission from Super Micro Computer, Inc., you may not copy any part of this document.

Information in this document is subject to change without notice. Other products and companies referred to herein are trademarks or registered trademarks of their respective companies or mark holders.

Copyright © 2009 by Super Micro Computer, Inc.
All rights reserved.

Printed in the United States of America

Preface

About This Manual

This manual is written for professional system integrators and PC technicians. It provides information for the installation and use of the 2021M-T2R+/2021M-82R+ server. Installation and maintenance should be performed by experienced technicians only.

The 2021M-T2R+/2021M-82R+ is a high-end server based on the SC825TQ-R700LP/SC825S2-R700LP 2U rackmount chassis and the H8DME-2/H8DM8-2, a dual processor serverboard that supports AMD Opteron 2000 series processors and up to 32/32/64 GB of registered ECC DDR2-667/533/400 SDRAM.

Manual Organization

Chapter 1: Introduction

The first chapter provides a checklist of the main components included with the server system and describes the main features of the H8DME-2/H8DM8-2 serverboard and the SC825TQ-R700LP/SC825S2-R700LP chassis, which comprise the 2021M-T2R+/2021M-82R+ .

Chapter 2: Server Installation

This chapter describes the steps necessary to install the 2021M-T2R+/2021M-82R+ into a rack and check out the server configuration prior to powering up the system. If your server was ordered without processor and memory components, this chapter will refer you to the appropriate sections of the manual for their installation.

Chapter 3: System Interface

Refer here for details on the system interface, which includes the functions and information provided by the control panel on the chassis as well as other LEDs located throughout the system.

Chapter 4: System Safety

You should thoroughly familiarize yourself with this chapter for a general overview of safety precautions that should be followed when installing and servicing the 1011S-MR2.

Chapter 5: Advanced Serverboard Setup

Chapter 5 provides detailed information on the H8DME-2/H8DM8-2 serverboard, including the locations and functions of connections, headers and jumpers. Refer to this chapter when adding or removing processors or main memory and when reconfiguring the serverboard.

Chapter 6: Advanced Chassis Setup

Refer to Chapter 6 for detailed information on the SC825TQ-R700LP/SC825S2-R700LP server chassis. You should follow the procedures given in this chapter when installing, removing or reconfiguring SATA/SCSI or peripheral drives and when replacing a system power supply or cooling fan.

Chapter 7: BIOS

The BIOS chapter includes an introduction to BIOS and provides detailed information on running the CMOS Setup Utility.

Appendix A: BIOS Error Beep Codes

Appendix B: BIOS POST Checkpoint Codes

Appendix C: System Specifications

Notes

Table of Contents

Preface

About This Manual	iii
Manual Organization	iii

Chapter 1: Introduction

1-1 Overview	1-1
1-2 Serverboard Features	1-2
1-3 Server Chassis Features	1-4
1-4 Contacting Supermicro	1-6

Chapter 2: Server Installation

2-1 Overview	2-1
2-2 Unpacking the System	2-1
2-3 Preparing for Setup	2-1
2-4 Installing the System into a Rack	2-4
2-5 Checking the Serverboard Setup	2-8
2-6 Checking the Drive Bay Setup	2-10

Chapter 3: System Interface

3-1 Overview	3-1
3-2 Control Panel Buttons	3-1
Reset	3-1
Power	3-1
3-3 Control Panel LEDs	3-2
Power Fail	3-2
Overheat/Fan Fail	3-2
NIC1	3-2
NIC2	3-2
HDD	3-3
Power	3-3
3-4 Drive Carrier LEDs	3-3

Chapter 4: System Safety

4-1 Electrical Safety Precautions	4-1
4-2 General Safety Precautions	4-2
4-3 ESD Precautions	4-3
4-4 Operating Precautions	4-4

Chapter 5: Advanced Serverboard Setup

5-1	Handling the Serverboard	5-1
5-2	Processor and Heatsink Installation	5-2
5-3	Connecting Cables	5-5
	Connecting Data Cables	5-5
	Connecting Power Cables	5-5
	Connecting the Control Panel	5-6
5-4	I/O Ports	5-7
5-5	Installing Memory	5-7
5-6	Adding PCI Cards	5-10
5-7	Serverboard Details	5-11
	H8DME-2/H8DM8-2 Layout	5-11
	H8DME-2/H8DM8-2 Quick Reference	5-12
5-8	Connector Definitions	5-13
	ATX Power Connector	5-13
	Processor Power Connector	5-13
	Auxiliary Power Connector	5-13
	Power LED	5-13
	HDD LED	5-14
	NIC1 LED	5-14
	NIC2 LED	5-14
	Overheat/Fan Fail LED	5-14
	Power Fail LED	5-14
	Reset Button	5-15
	Power Button	5-15
	USB0/1 (Universal Serial Bus Ports)	5-15
	USB2/3 Headers	5-15
	ATX PS/2 Keyboard and Mouse Ports	5-16
	Serial Ports	5-16
	Fan Headers	5-16
	JLAN1/2 (Ethernet Ports)	5-16
	Power LED/Speaker	5-17
	Overheat LED	5-17
	Chassis Intrusion	5-17
	Wake-On-LAN	5-17
	Wake-On-Ring	5-17
	Power Supply I ² C Header	5-18
	SMBus Header	5-18
	3rd Power Supply Alarm Header	5-18

Power Fail Alarm Reset Header	5-19
Compact Flash Power Header	5-19
SGPIO	5-19
5-9 Jumper Settings	5-20
Explanation of Jumpers	5-20
CMOS Clear	5-20
3rd Power Supply Fail Detect Enable/Disable	5-21
I ² C to PCI Enable/Disable	5-21
Watch Dog Enable/Disable	5-21
Onboard Speaker Enable/Disable	5-22
PCI-X Slot Speed	5-22
SCSI Controller Enable/Disable	5-22
SCSI Termination Enable/Disable	5-23
VGA Enable/Disable	5-23
Compact Flash Master/Slave	5-23
5-10 Onboard Indicators	5-24
JLAN1/JLAN2 LEDs	5-24
+3.3V Standby LED	5-24
SCSI Activity LEDs	5-24
5-11 Floppy, IDE, SCSI and SATA Drive Connections	5-25
Floppy Connector	5-25
IDE Connector	5-26
SATA Ports	5-26
SCSI Connectors	5-27
5-12 Enabling SATA RAID	5-28
5-13 Installing Additional Drivers	5-30

Chapter 6: Advanced Chassis Setup

6-1 Static-Sensitive Devices	6-1
6-2 Control Panel	6-2
6-3 System Fans	6-2
System Fan Failure	6-3
Replacing System Fans	6-3
6-4 Drive Bay Installation/Removal	6-4
Accessing the Drive Bays	6-4
SATA/SCSI Drive Installation	6-5
DVD-ROM and Floppy Drive Installation	6-7
6-5 Power Supply	6-8
Power Supply Failure	6-8

Replacing the Power Supply	6-6
----------------------------------	-----

Chapter 7: BIOS

7-1 Introduction	7-1
7-2 Main Menu	7-2
7-3 Advanced Settings Menu	7-2
7-4 Boot Menu	7-16
7-5 Security Menu	7-17
7-6 Exit Menu	7-18

Appendices:

Appendix A: BIOS Error Beep Codes	A-1
Appendix B: BIOS POST Checkpoint Codes	B-1
Appendix C: System Specifications	C-1

Notes

Chapter 1

Introduction

1-1 Overview

The AS2021M-T2R+/2021M-82R+ is a high-end server that is comprised of two main subsystems: the SC825TQ-R700LP/SC825S2-R700LP 2U server chassis and the H8DME-2/H8DM8-2 dual AMD processor serverboard. Please refer to our web site for information on operating systems that have been certified for use with the 2021M-T2R+/2021M-82R+ (www.supermicro.com).

In addition to the serverboard and chassis, various hardware components have been included with the 2021M-T2R+/2021M-82R+, as listed below:

- Three (3) 8-cm hot-swap chassis fans (FAN-0094L)
- One (1) air shroud (MCP-310-00025-00)
- Two (2) CPU passive heatsinks (SNK-P0023P)
- One (1) DVD-ROM drive (DVM-PNSC-824)
- One (1) floppy disk drive, optional (FPD-TEAC-SB)
- One (1) cable for DVD drive (CBL-0139L)
- One (1) floppy cable (CBL-040L)
- One (1) front control panel cable (CBL-0087)
- One (1) rail set (MCP-290-00002-00)
- SATA Accessories (2021M-T2R+ only)
 - One (1) SATA backplane (BPN-SAS-825TQ)
 - One (1) 2-ft SATA cable (CBL-0044L)
 - Two (2) 35-cm SATA cables (CBL-0061L)
 - Two (2) SGPIO ribbon cables (CBL-0157L)
 - Two (2) 48-cm SATA cables (CBL-0178L)
 - One (1) 70-cm SATA cable (CBL-0179L)
 - Eight (8) SATA hot-swap drive carriers [MCP-220-00001-03(01)]*
(The chassis has eight carriers but only six SATA drives are supported.)

- SCSI Accessories 2021M-82R+ only)
 - One (1) dual-channel SCSI backplane (BPN-SCA-825S2)
 - One (1) Ultra320 SCSI 6-in ribbon cable (CBL-037L-U320)
 - One (1) Ultra320 SCSI 9-in round cable (CBL-0043L)
 - Eight (8) SCSI hot-swap drive carriers [MCP-220-00001-03(01)]*
- One (1) CD containing drivers and utilities

*The 2021M-T2R+/2021M-82R+ is available in silver and black; a "V" following a part number indicates silver and "B" indicates black.

1-2 Serverboard Features

At the heart of the 2021M-T2R+/2021M-82R+ lies the H8DME-2/H8DM8-2, a dual processor serverboard based on the nVidia MCP55 Pro chipset and designed to provide maximum performance. Below are the main features of the H8DME-2/H8DM8-2. (See Figure 1-1 for a block diagram of the MCP55 Pro chipset).

Processors

The H8DME-2/H8DM8-2 supports single or dual AMD Opteron 2000 Series, Socket F type processors. Please refer to the serverboard description pages on our web site for a complete listing of supported processors (www.supermicro.com/aplus).

Memory

The H8DME-2/H8DM8-2 has sixteen 240-pin DIMM slots that can support up to 32/32/64 GB of registered ECC DDR2-667/533/400 SDRAM. The memory operates in an interleaved configuration and requires requires modules of the same size and speed to be installed two at a time. See Chapter 5 Section 5 for details.

Serial ATA

A SATA controller is integrated into the chipset to provide a six-port Serial ATA subsystem, which is RAID 0, 1, 0+1, 5 and JBOD supported. The Serial ATA drives are hot-swappable units.

Note: The operating system you use must have RAID support to enable the hot-swap capability and RAID function of the Serial ATA drives.

Onboard SCSI (2021M-82R+ only)

An onboard Adaptec AIC-7902W dual-channel SCSI controller is integrated into the H8DM8-2, which supports eight 80-pin SCA Ultra320 SCSI hard drives. The SCSI drives are connected to an SCA backplane that provides power, bus termination and configuration settings. The SCSI drives are hot-swappable units.

Note: The operating system you use must have RAID support to enable the hot-swap capability and RAID function of the SCSI drives.

PCI Expansion Slots

The H8DME-2/H8DM8-2 has six PCI expansion slots, which includes two PCI-Express x8 slots, two 64-bit 133 MHz PCI-X slots and two 64-bit 100 MHz PCI-X slots. (On the H8DM8-2, one 100 MHz PCI-X slot supports Zero Channel RAID.)

Onboard Controllers/Ports

One floppy drive controller and one onboard ATA/133 controllers are provided to support up to two IDE hard drives or ATAPI devices. The color-coded I/O ports include one COM port (an additional COM header is located on the serverboard), a VGA (monitor) port, two USB 2.0 ports, PS/2 mouse and keyboard ports and two gigabit Ethernet ports.

ATI Graphics Controller

The H8DME-2/H8DM8-2 features an integrated ATI video controller based on the ES1000 graphics chip. The ES1000 was designed specifically for servers, featuring low power consumption, high reliability and superior longevity.

Other Features

Other onboard features that promote system health include onboard voltage monitors, a chassis intrusion header, auto-switching voltage regulators, chassis and CPU overheat sensors, virus protection and BIOS rescue.

1-3 Server Chassis Features

The following is a general outline of the main features of the SC825TQ-R700LP/SC825S2-R700LP server chassis.

System Power

The SC825TQ-R700LP/SC825S2-R700LP features a redundant 700W power supply composed of two separate power modules. This power redundancy feature allows you to replace a failed power supply without shutting down the system.

Serial ATA Subsystem (2021M-T2R+ only)

The SC825TQ-R700LP supports up to six 3 Gb/s Serial ATA drives. The Serial ATA drives are hot-swappable units and are connected to a backplane that provides power and control.

Note: The operating system you use must have RAID support to enable the hot-swap capability of the Serial ATA drives.

SCSI Subsystem (2021M-82R+ only)

The SC825S2-R700LP chassis was designed to support eight dual-channel SCSI hard drives, which are hot-swappable units.

Note: The operating system you use must have RAID support to enable the hot-swap capability of the SCSI drives.

Front Control Panel

The control panel on the 2021M-T2R+/2021M-82R+ provides you with system monitoring and control. LEDs indicate system power, HDD activity, network activity, system overheat and power supply failure. A main power button and a system reset button are also included. In addition, two USB ports and a COM port have been provided for front side access.

I/O Backplane

The SC825TQ-R700LP/SC825S2-R700LP is an ATX form factor chassis designed to be used in a 2U rackmount configuration. The I/O backplane provides seven low-profile PCI expansion slots, one COM port, a VGA port, two USB 2.0 ports, PS/2 mouse and keyboard ports and two Gb Ethernet ports.

Cooling System

The SC825TQ-R700LP/SC825S2-R700LP chassis has an innovative cooling design that includes three 8-cm hot-plug system cooling fans located in the middle section of the chassis. An air shroud channels the airflow from the system fans to efficiently cool the processor area of the system. The power supply module also includes a cooling fan.

**Figure 1-1. Intel nVidia MCP55 Pro Chipset:
System Block Diagram**

Note: This is a general block diagram. Please see Chapter 5 for details.

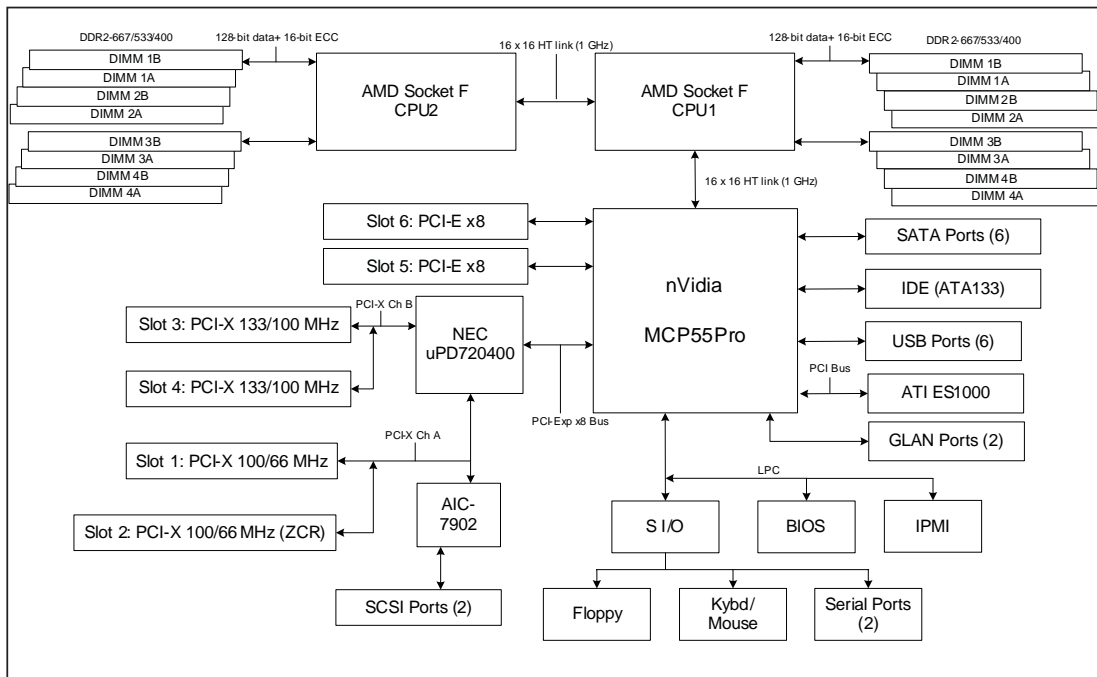

Note: The AIC-7902 SCSI controller is only on the H8DM8-2 serverboard.

1-4 Contacting Supermicro

Headquarters

Address: Super Micro Computer, Inc.
980 Rock Ave.
San Jose, CA 95131 U.S.A.

Tel: +1 (408) 503-8000

Fax: +1 (408) 503-8008

Email: marketing@supermicro.com (General Information)
support@supermicro.com (Technical Support)

Web Site: www.supermicro.com

Europe

Address: Super Micro Computer B.V.
Het Sterrenbeeld 28, 5215 ML
's-Hertogenbosch, The Netherlands

Tel: +31 (0) 73-6400390

Fax: +31 (0) 73-6416525

Email: sales@supermicro.nl (General Information)
support@supermicro.nl (Technical Support)
rma@supermicro.nl (Customer Support)

Asia-Pacific

Address: Super Micro Computer, Inc.
4F, No. 232-1, Liancheng Rd.
Chung-Ho 235, Taipei County
Taiwan, R.O.C.

Tel: +886-(2) 8226-3990

Fax: +886-(2) 8226-3991

Web Site: www.supermicro.com.tw

Technical Support:

Email: support@supermicro.com.tw

Tel: 886-2-8228-1366, ext.132 or 139

Chapter 2

Server Installation

2-1 Overview

This chapter provides a quick setup checklist to get your 2021M-T2R+/2021M-82R+ up and running. Following these steps in the order given should enable you to have the system operational within a minimum amount of time. This quick setup assumes that your system has come to you with the processors and memory preinstalled. If your system is not already fully integrated with a serverboard, processors, system memory etc., please turn to the chapter or section noted in each step for details on installing specific components.

2-2 Unpacking the System

You should inspect the box the 2021M-T2R+/2021M-82R+ was shipped in and note if it was damaged in any way. If the server itself shows damage you should file a damage claim with the carrier who delivered it.

Decide on a suitable location for the rack unit that will hold the server. It should be situated in a clean, dust-free area that is well ventilated. Avoid areas where heat, electrical noise and electromagnetic fields are generated. You will also need it placed near a grounded power outlet. Read the Rack and Server Precautions in the next section.

2-3 Preparing for Setup

The box the 2021M-T2R+/2021M-82R+ was shipped in should include two sets of rail assemblies, two rail mounting brackets and the mounting screws you will need to install the system into the rack. Follow the steps in the order given to complete the installation process in a minimum amount of time. Please read this section in its entirety before you begin the installation procedure outlined in the sections that follow.

Choosing a Setup Location

- Leave enough clearance in front of the rack to enable you to open the front door completely (~25 inches).
- Leave approximately 30 inches of clearance in the back of the rack to allow for sufficient airflow and ease in servicing.
- This product is for installation only in a Restricted Access Location (dedicated equipment rooms, service closets and the like).



Warnings and Precautions!



Rack Precautions

- Ensure that the leveling jacks on the bottom of the rack are fully extended to the floor with the full weight of the rack resting on them.
- In single rack installation, stabilizers should be attached to the rack.
- In multiple rack installations, the racks should be coupled together.
- Always make sure the rack is stable before extending a component from the rack.
- You should extend only one component at a time - extending two or more simultaneously may cause the rack to become unstable.

Server Precautions

- Review the electrical and general safety precautions in Chapter 4.
- Determine the placement of each component in the rack *before* you install the rails.
- Install the heaviest server components on the bottom of the rack first, and then work up.
- Use a regulating uninterruptible power supply (UPS) to protect the server from power surges, voltage spikes and to keep your system operating in case of a power failure.
- Allow the hot plug SATA/SCSI drives and power supply units to cool before touching them.
- Always keep the rack's front door and all panels and components on the servers closed when not servicing to maintain proper cooling.

Rack Mounting Considerations

Ambient Operating Temperature

If installed in a closed or multi-unit rack assembly, the ambient operating temperature of the rack environment may be greater than the ambient temperature of the room. Therefore, consideration should be given to installing the equipment in an environment compatible with the manufacturer's maximum rated ambient temperature (T_{mra}).

Reduced Airflow

Equipment should be mounted into a rack so that the amount of airflow required for safe operation is not compromised.

Mechanical Loading

Equipment should be mounted into a rack so that a hazardous condition does not arise due to uneven mechanical loading.

Circuit Overloading

Consideration should be given to the connection of the equipment to the power supply circuitry and the effect that any possible overloading of circuits might have on overcurrent protection and power supply wiring. Appropriate consideration of equipment nameplate ratings should be used when addressing this concern.

Reliable Ground

A reliable ground must be maintained at all times. To ensure this, the rack itself should be grounded. Particular attention should be given to power supply connections other than the direct connections to the branch circuit (i.e. the use of power strips, etc.).

2-4 Installing the System into a Rack

This section provides information on installing the 2021M-T2R+/2021M-82R+ into a rack unit. If the 2021M-T2R+/2021M-82R+ has already been mounted into a rack, you can skip ahead to Sections 2-5 and 2-6. There are a variety of rack units on the market, which may mean the assembly procedure will differ slightly. The following is a guideline for installing the system into a rack with the rack rails provided. You should also refer to the installation instructions that came with the rack unit you are using.

Identifying the Sections of the Rack Rails

You should have received a total of six rack rail sections with the 2021M-T2R+/2021M-82R+. Two of these sections secure directly to the 2021M-T2R+/2021M-82R+ and the third (which actually consists of two joined sections) secures directly to the rack itself. All screws and hardware mentioned in the installation steps should be included in the hardware kit.

Refer to Figure 2-1 to determine which rail section gets attached to the front of the chassis and which gets attached to the rear of the chassis. (The longer of the two is the front section. The third rail section attaches to the rack.)

Installing the Chassis Rails

Position the front and rear chassis rail sections along the side of the 2021M-T2R+/2021M-82R+ making sure the screw holes line up. Note that these two rails are left/right specific. Screw the front chassis rail (the long piece) securely to the side of the chassis (see Figure 2-1, step 1). There should be two screws for each side. Repeat this procedure for the other rail on the opposite side of the chassis. Then attach the two rear chassis rails to the chassis in the same manner, again keeping in mind that the rails are left/right specific. (You will also need to attach the rail brackets when installing into a telco rack.)

Locking Tabs: Both front chassis rails and the rack rails have a locking tab, which serves two functions. The first is to lock the server into place when installed and pushed fully into the rack, which is its normal position. Secondly, these tabs also lock the server in place when fully extended from the rack. This prevents the server from coming completely out of the rack when you pull it out for servicing.

Figure 2-1. Installing Chassis Rails

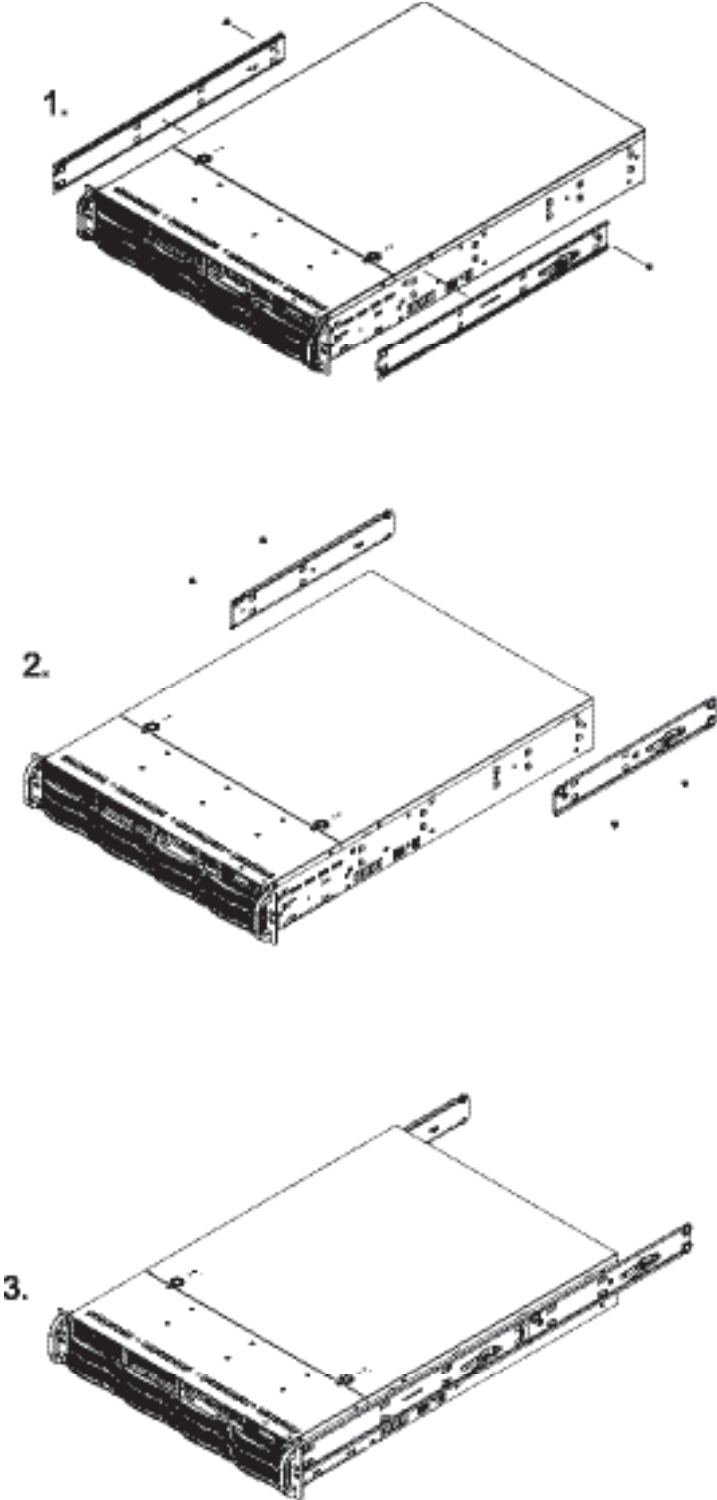

Installing the Rack Rails:

Determine where you want to place the 2021M-T2R+/2021M-82R+ in the rack. (See [Rack and Server Precautions in Section 2-3.](#)) Position the fixed rack rail/sliding rail guide assemblies (made up of two inter-locking sections) at the desired location in the rack, keeping the sliding rail guide facing the inside of the rack and the rollers toward the front of the rack. Screw the assembly securely to the rack. Attach the other assembly to the other side of the rack, making sure both are at the exact same height and with the rail guides facing inward.

Installing the Server into the Rack

You should now have rails attached to both the chassis and the rack unit. The next step is to install the server into the rack. Do this by lining up the rear of the chassis rails with the front of the rack rails. Slide the chassis rails into the rack rails, keeping the pressure even on both sides (you may have to depress the locking tabs when inserting). See Figure 2-2.

When the server has been pushed completely into the rack, you should hear the locking tabs "click". Finish by inserting and tightening the thumbscrews that hold the front of the server to the rack.

Installing the Server into a Telco Rack

If you are installing the 2021M-T2R+/2021M-82R+ into a Telco type rack, follow the directions given on the previous pages for rack installation. The only difference in the installation procedure will be the positioning of the rack brackets to the rack. They should be spaced apart just enough to accommodate the width of the telco rack.

Figure 2-2. Installing the Server into a Rack

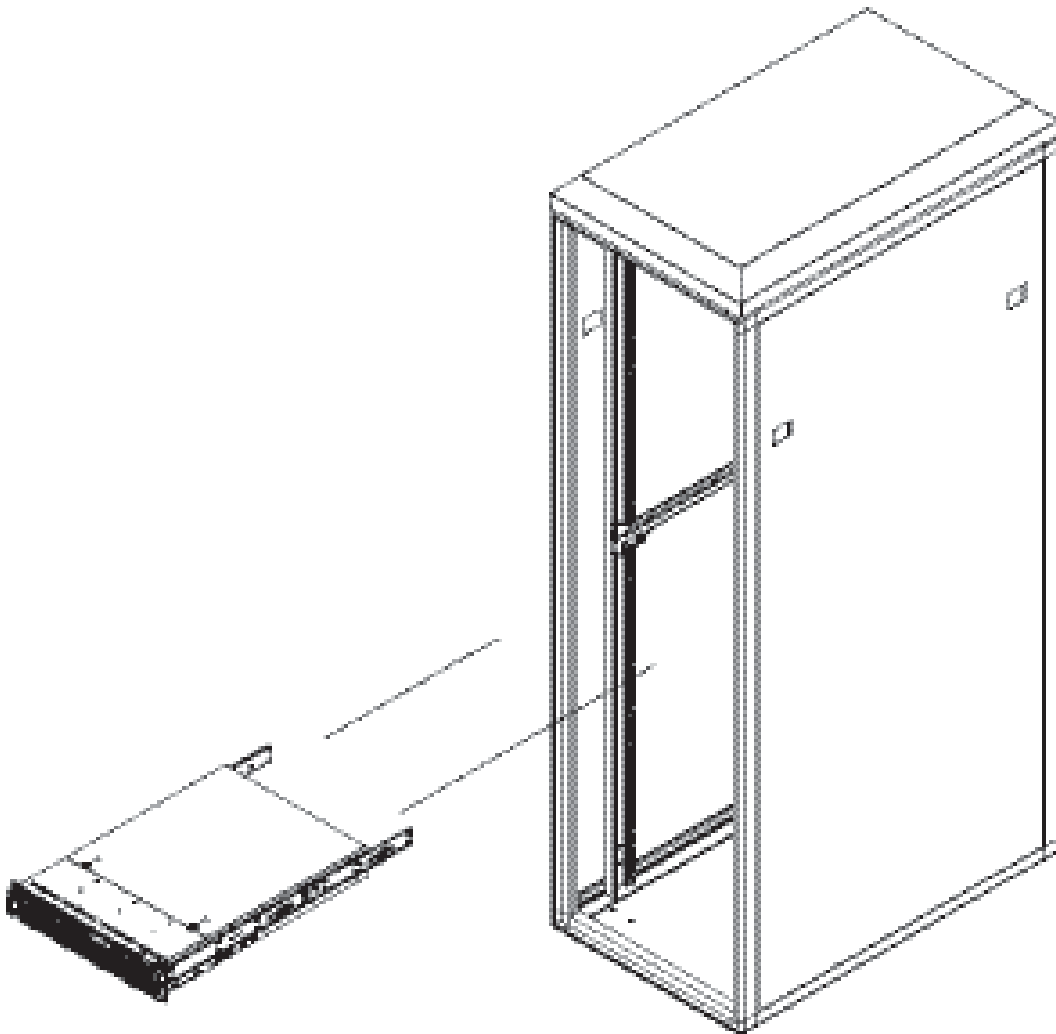

2-5 Checking the Serverboard Setup

After you install the 2021M-T2R+/2021M-82R+ in the rack, you will need to open the unit to make sure the serverboard is properly installed and all the connections have been made.

1. Accessing the inside of the System (see Figure 2-3)

First, grasp the two handles on either side and pull the unit straight out until it locks (you will hear a "click"). Next, depress the two buttons on the top of the chassis to release the top cover. You can then lift the top cover from the chassis to gain full access to the inside of the server.

2. Check the CPUs (processors)

You may have one or two processors already installed into the serverboard. Each processor needs its own heatsink. See Chapter 5 for instructions on processor and heatsink installation.

3. Check the system memory

Your 2021M-T2R+/2021M-82R+ server system may have come with system memory already installed. Make sure all DIMMs are fully seated in their slots. For details on adding system memory, refer to Chapter 5.

4. Installing add-on cards

If desired, you can install add-on cards to the system. See Chapter 5 for details on installing PCI add-on cards.

5. Check all cable connections and airflow

Make sure all power and data cables are properly connected and not blocking the chassis airflow. Also make sure that no cables are positioned in front of the fans. See Chapter 5 for details on cable connections.

Figure 2-3. Accessing the Inside of the System

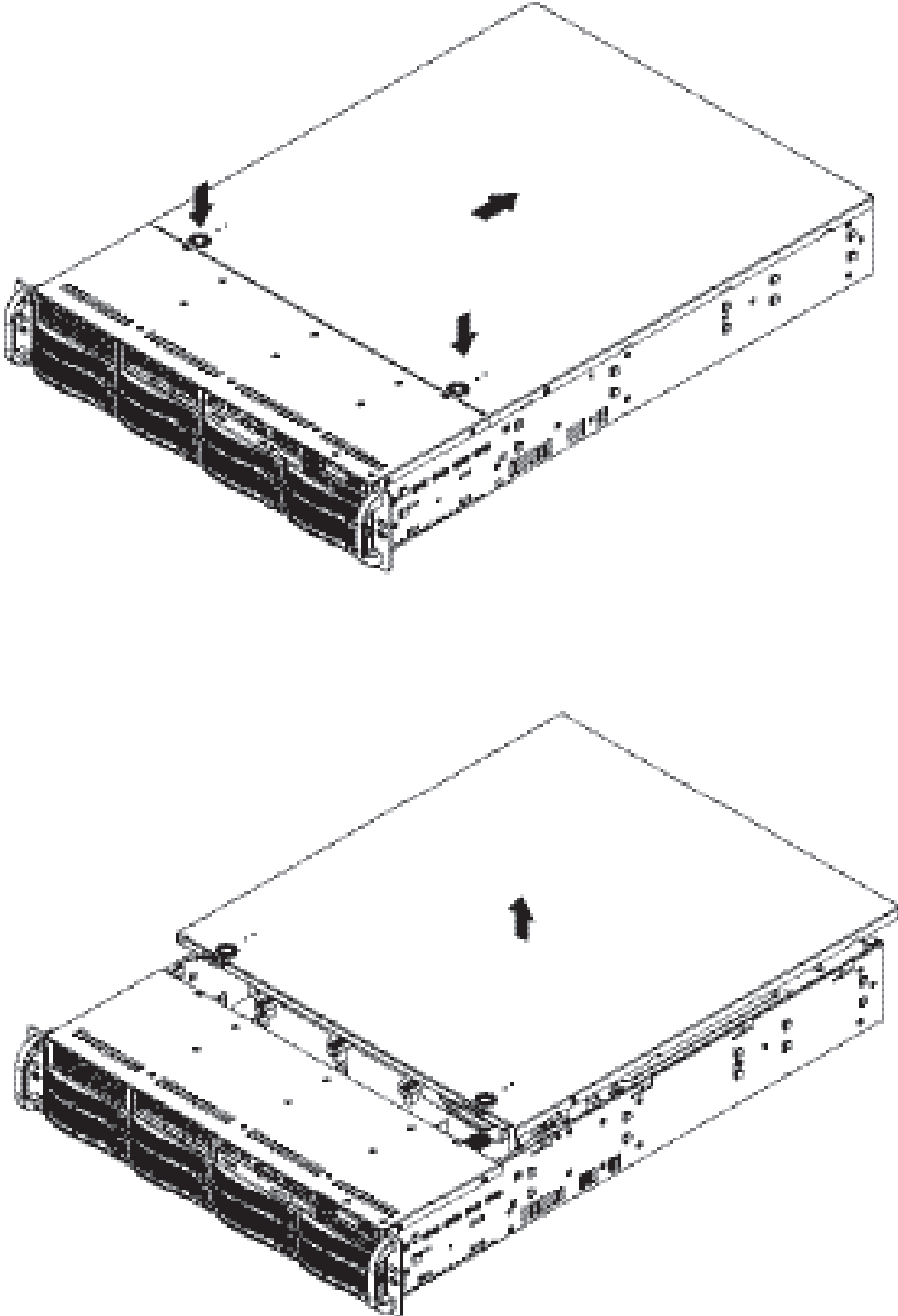

2-6 Checking the Drive Bay Setup

Next, you should check to make sure the peripheral drives and the Serial ATA drives have been properly installed and all connections have been made.

1. Accessing the drive bays

All drives are accessible from the front of the server. For servicing the DVD-ROM and floppy drives, you will need to remove the top chassis cover. The Serial ATA and SCSI disk drives can be installed and removed from the front of the chassis without removing the top chassis cover.

2. DVD-ROM and floppy disk drives

A slim DVD-ROM and a floppy drive should be preinstalled in your server. Refer to Chapter 6 if you need to reinstall a DVD-ROM and/or floppy disk drive to the system.

3. Check the SATA/SCSI drives

Depending upon your system's configuration, your system may have one or more drives already installed. If you need to install SATA/SCSI drives, please refer to Chapter 6.

4. Check the airflow

Airflow is provided by three 8-cm center chassis cooling fans. An air shroud is also included in the system to maximize airflow. The system component layout was carefully designed to direct sufficient cooling airflow to the components that generate the most heat. Note that all power and data cables have been routed in such a way that they do not block the airflow generated by the fans.

5. Supplying power to the system

The last thing you must do is to provide input power to the system. Plug the power cords from the power supply units into a high-quality power strip that offers protection from electrical noise and power surges. It is recommended that you use an uninterruptible power supply (UPS).

Chapter 3

System Interface

3-1 Overview

There are several LEDs on the control panel as well as others on the SATA and SCSI drive carriers to keep you constantly informed of the overall status of the system as well as the activity and health of specific components. There are also two buttons on the chassis control panel.

3-2 Control Panel Buttons

The two push-buttons located on the front of the chassis are a reset button and a power on/off button.

RESET

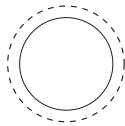

- **RESET:** Use the reset button to reboot the system.



- **POWER:** This is the main power button, which is used to apply or turn off the main system power. Turning off system power with this button removes the main power but keeps standby power supplied to the system.

3-3 Control Panel LEDs

The control panel located on the front of the chassis has several LEDs. These LEDs provide you with critical information related to different parts of the system. This section explains what each LED indicates when illuminated and any corrective action you may need to take.



- **Power Fail:** Indicates a power supply module has failed. The second power supply module will take the load and keep the system running but the failed module will need to be replaced. Refer to Chapter 6 for details on replacing the power supply. This LED should be off when the system is operating normally.



- **Overheat/Fan Fail:** When this LED flashes, it indicates a fan failure. When on continuously it indicates an overheat condition, which may be caused by cables obstructing the airflow in the system or the ambient room temperature being too warm. Check the routing of the cables and make sure all fans are present and operating normally. You should also check to make sure that the chassis covers are installed. Finally, verify that the heatsinks are installed properly (see Chapter 5). This LED will remain flashing or on as long as the indicated condition exists.



- **NIC1:** Indicates network activity on the JLAN1 port when flashing.



- **NIC2:** Indicates network activity on the JLAN2 port when flashing.



- **HDD:** Indicates IDE channel activity. On the 2021M-T2R+/2021M-82R+, this LED indicates SATA/SCSI and/or DVD-ROM drive activity when flashing.



- **Power:** Indicates power is being supplied to the system's power supply units. This LED should normally be illuminated when the system is operating.

3-4 Drive Carrier LEDs

SATA Drives (2021M-T2R+)

- **Green:** Each Serial ATA drive carrier has a green LED. When illuminated, this green LED (on the front of the SATA drive carrier) indicates drive activity. A connection to the SATA backplane enables this LED to blink on and off when that particular drive is being accessed. Please refer to Chapter 6 for instructions on replacing failed SATA drives.
- **Red:** The red LED to indicate an SATA drive failure. If one of the SATA drives fail, you should be notified by your system management software. Please refer to Chapter 6 for instructions on replacing failed SATA drives.

SCSI Drives (2021M-82R+)

Each SCSI drive carrier has two LEDs.

- **Green:** When illuminated, the green LED on the front of the SCSI drive carrier indicates drive activity. A connection to the SCSI SCA backplane enables this LED to blink on and off when that particular drive is being accessed.
- **Red:** The SAF-TE compliant backplane activates the red LED to indicate a drive failure. If one of the SCSI drives fail, you should be notified by your system management software. Please refer to Chapter 6 for instructions on replacing failed SCSI drives.

Notes

Chapter 4

System Safety

4-1 Electrical Safety Precautions



Basic electrical safety precautions should be followed to protect yourself from harm and the 2021M-T2R+/2021M-82R+ from damage:

- Be aware of the locations of the power on/off switch on the chassis as well as the room's emergency power-off switch, disconnection switch or electrical outlet. If an electrical accident occurs, you can then quickly remove power from the system.
- Do not work alone when working with high voltage components.
- Power should always be disconnected from the system when removing or installing main system components, such as the serverboard, memory modules and the DVD-ROM and floppy drives. When disconnecting power, you should first power down the system with the operating system and then unplug the power cords of all the power supply units in the system.
- When working around exposed electrical circuits, another person who is familiar with the power-off controls should be nearby to switch off the power if necessary.
- Use only one hand when working with powered-on electrical equipment. This is to avoid making a complete circuit, which will cause electrical shock. Use extreme caution when using metal tools, which can easily damage any electrical components or circuit boards they come into contact with.
- Do not use mats designed to decrease electrostatic discharge as protection from electrical shock. Instead, use rubber mats that have been specifically designed as electrical insulators.

- The power supply power cord must include a grounding plug and must be plugged into grounded electrical outlets.
- Serverboard Battery: **CAUTION** - There is a danger of explosion if the onboard battery is installed upside down, which will reverse its polarities (see Figure 4-1). This battery must be replaced only with the same or an equivalent type recommended by the manufacturer. Dispose of used batteries according to the manufacturer's instructions.
- DVD-ROM Laser: **CAUTION** - this server may have come equipped with a DVD-ROM drive. To prevent direct exposure to the laser beam and hazardous radiation exposure, do not open the enclosure or use the unit in any unconventional way.

4-2 General Safety Precautions



Follow these rules to ensure general safety:

- Keep the area around the 2021M-T2R+/2021M-82R+ clean and free of clutter.
- The 2021M-T2R+/2021M-82R+ weighs approximately 57 lbs (25.9 kg.) when fully loaded. When lifting the system, two people at either end should lift slowly with their feet spread out to distribute the weight. Always keep your back straight and lift with your legs. Don't use the handles (if installed) to lift the chassis; the handles should only be used to pull the server out of the rack.
- Place the chassis top cover and any system components that have been removed away from the system or on a table so that they won't accidentally be stepped on.
- While working on the system, do not wear loose clothing such as neckties and unbuttoned shirt sleeves, which can come into contact with electrical circuits or be pulled into a cooling fan.
- Remove any jewelry or metal objects from your body, which are excellent metal conductors that can create short circuits and harm you if they come into contact with printed circuit boards or areas where power is present.

- After accessing the inside of the system, close the system back up and secure it to the rack unit with the retention screws after ensuring that all connections have been made.

4-3 ESD Precautions



Electrostatic discharge (ESD) is generated by two objects with different electrical charges coming into contact with each other. An electrical discharge is created to neutralize this difference, which can damage electronic components and printed circuit boards. The following measures are generally sufficient to neutralize this difference before contact is made to protect your equipment from ESD:

- Use a grounded wrist strap designed to prevent static discharge.
- Keep all components and printed circuit boards (PCBs) in their antistatic bags until ready for use.
- Touch a grounded metal object before removing the board from the antistatic bag.
- Do not let components or PCBs come into contact with your clothing, which may retain a charge even if you are wearing a wrist strap.
- Handle a board by its edges only; do not touch its components, peripheral chips, memory modules or contacts.
- When handling chips or modules, avoid touching their pins.
- Put the serverboard and peripherals back into their antistatic bags when not in use.
- For grounding purposes, make sure your computer chassis provides excellent conductivity between the power supply, the case, the mounting fasteners and the serverboard.

4-4 Operating Precautions



Care must be taken to assure that the chassis cover is in place when the 2021M-T2R+/2021M-82R+ is operating to assure proper cooling. Out of warranty damage to the 2021M-T2R+/2021M-82R+ system can occur if this practice is not strictly followed.

Figure 4-1. Installing the Onboard Battery

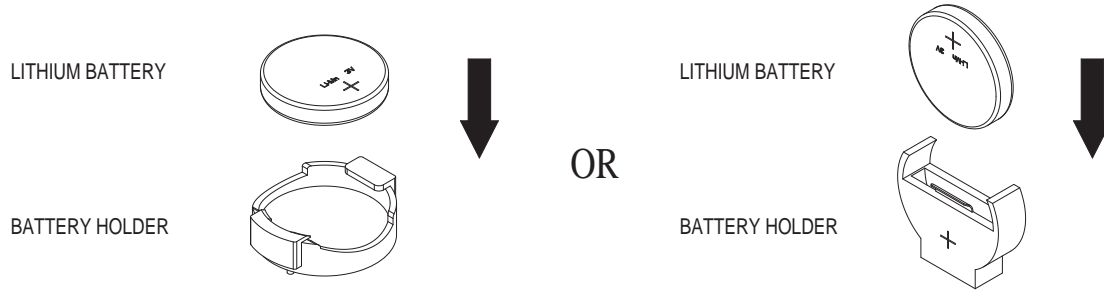

Chapter 5

Advanced Serverboard Setup

This chapter covers the steps required to install processors and heatsinks to the H8DME-2/H8DM8-2 serverboard, connect the data and power cables and install add-on cards. All serverboard jumpers and connections are described and a layout and quick reference chart are included in this chapter. Remember to close the chassis completely when you have finished working on the serverboard to protect and cool the system sufficiently.

5-1 Handling the Serverboard

Static electrical discharge can damage electronic components. To prevent damage to printed circuit boards, it is important to handle them very carefully (see Chapter 4). Also note that the size and weight of the serverboard can cause it to bend if handled improperly, which may result in damage. To prevent the serverboard from bending, keep one hand under the center of the board to support it when handling. The following measures are generally sufficient to protect your equipment from static discharge.

Precautions

- Use a grounded wrist strap designed to prevent static discharge.
- Touch a grounded metal object before removing any board from its antistatic bag.
- Handle a board by its edges only; do not touch its components, peripheral chips, memory modules or gold contacts.
- When handling chips or modules, avoid touching their pins.
- Put the serverboard, add-on cards and peripherals back into their antistatic bags when not in use.

Unpacking

The serverboard is shipped in antistatic packaging to avoid static damage. When unpacking the board, make sure the person handling it is static protected.

5-2 Processor and Heatsink Installation



Exercise extreme caution when handling and installing the processor. Always connect the power cord last and always remove it before adding, removing or changing any hardware components.

Installing the CPU Backplates

Two CPU backplates (BKT-0011L) have been preinstalled to the serverboard to prevent the CPU area of the serverboard from bending and to provide a base for attaching the heatsink retention modules.

Installing the Processor (install to the CPU#1 socket first)

1. Begin by removing the cover plate that protects the CPU. Lift the lever on CPU socket #1 until it points straight up. With the lever raised, lift open the silver CPU retention plate.

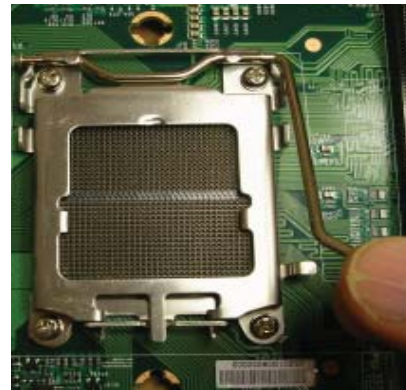

2. Use your thumb and your index finger to hold the CPU. Locate and align pin 1 of the CPU socket with pin 1 of the CPU. Both are marked with a triangle.

Triangles



3. Align pin 1 of the CPU with pin 1 of the socket. Once aligned, carefully place the CPU into the socket. *Do not drop the CPU on the socket, move the CPU horizontally or vertically or rub the CPU against the socket or against any pins of the socket, which may damage the CPU and/or the socket.*



4. With the CPU inserted into the socket, inspect the four corners of the CPU to make sure that it is properly installed and flush with the socket. Then, gently lower the silver CPU retention plate into place.



5. Carefully press the CPU socket lever down until it locks into its retention tab. For a dual-processor system, repeat these steps to install another CPU into the CPU#2 socket.

Note: if using a single processor, only the CPU1 DIMM slots are addressable for a maximum of 16 GB memory.



Installing the Heatsink Retention Modules

Two heatsink retention modules (BKT-0012L) and four screws are included in the retail box. Once installed, these are used to help attach the heatsinks to the CPUs. To install, align the module with the standoffs of the preinstalled CPU backplate and with the four feet on the module contacting the serverboard. Secure the retention module to the backplate with two of the screws provided. See Figure 2-1. Repeat for the second CPU socket.

Note: BKT-0012L is included for use with non-proprietary heatsinks only. When installing proprietary heatsinks, only BKT-0011L (the CPU backplate) is needed. The BKT-0012L retention module was designed to provide compatibility with clip-and-cam type heatsinks from third parties.

Figure 2-1. CPU Heatsink Retention Module Installation

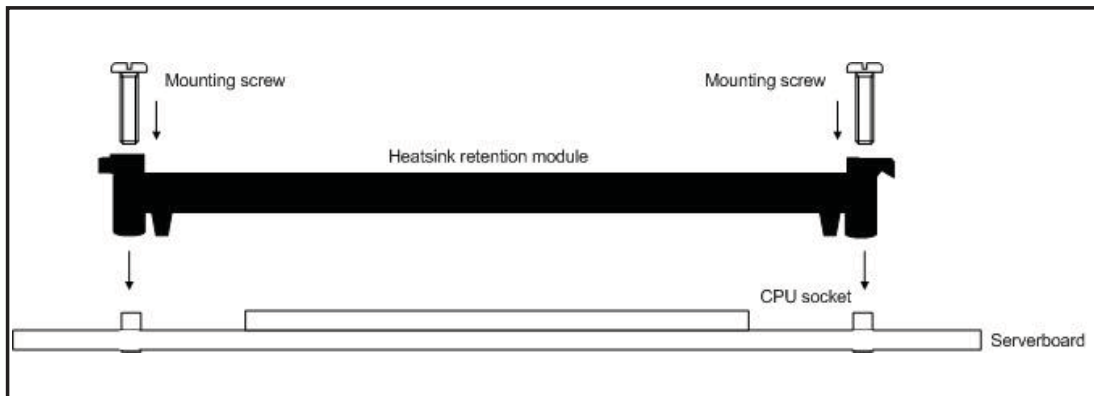

Installing the Heatsink

The use of active type heatsinks (except for 1U systems) are recommended. Connect the heatsink fans to the appropriate fan headers on the serverboard. To install the heatsinks, please follow the installation instructions included with your heatsink package (not included).

5-3 Connecting Cables

Now that the processors are installed, the next step is to connect the cables to the serverboard. These include the data (ribbon) cables for the peripherals and control panel and the power cables.

Connecting Data Cables

The ribbon cables used to transfer data from the peripheral devices have been carefully routed in preconfigured systems to prevent them from blocking the flow of cooling air that moves through the system from front to back. If you need to disconnect any of these cables, you should take care to reroute them as they were originally after reconnecting them (make sure the red wires connect to the pin 1 locations). If you are configuring the system, keep the airflow in mind when routing the cables. The following data cables (with their serverboard connector locations noted) should be connected. See the serverboard layout diagram in this chapter for connector locations.

- DVD-ROM drive cable (IDE#1)
- 2021M-T2R+: SATA cables (SATA0 ~ SATA5)
- 2021M-T2R+: SATA Enclosure Management LED cable (SGPIO1)
- 2021M-82R+: SCSI cables (JA1, JA2)
- Control Panel cable (JF1, see next page)

Connecting Power Cables

The H8DME-2/H8DM8-2 has a 24-pin primary power supply connector designated "JPW1" for connection to the ATX power supply. Connect the appropriate connector from the power supply to the "ATX Power" connector to supply power to the serverboard. See the Connector Definitions section in this chapter for power connector pin definitions.

In addition, your power supply must be connected to the 4-pin Secondary ATX Power connection at J32 and the 8-pin processor power connector at JPW2.

Connecting the Control Panel

JF1 contains header pins for various front control panel connectors. See Figure 5-3 for the pin locations of the various front control panel buttons and LED indicators. Please note that even and odd numbered pins are on opposite sides of each header.

All JF1 wires have been bundled into single keyed ribbon cable to simplify their connection. The red wire in the ribbon cable plugs into pin 1 of JF1. Connect the other end of the cable to the Control Panel printed circuit board, located just behind the system status LEDs in the chassis.

See the Connector Definitions section in this chapter for details and pin descriptions of JF1.

Figure 5-3. Front Control Panel Header Pins (JF1)

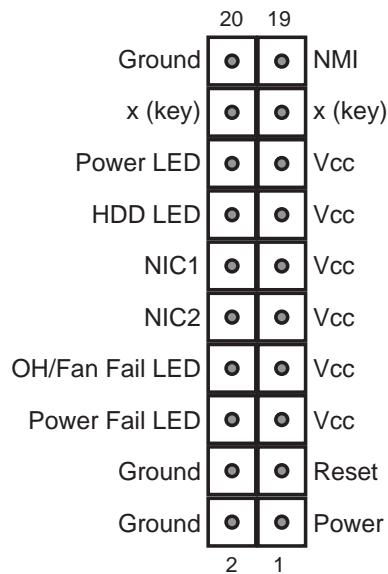

5-4 I/O Ports

The I/O ports are color coded in conformance with the PC 99 specification. See Figure 5-4 below for the colors and locations of the various I/O ports.

Figure 5-4. Rear Panel I/O Ports

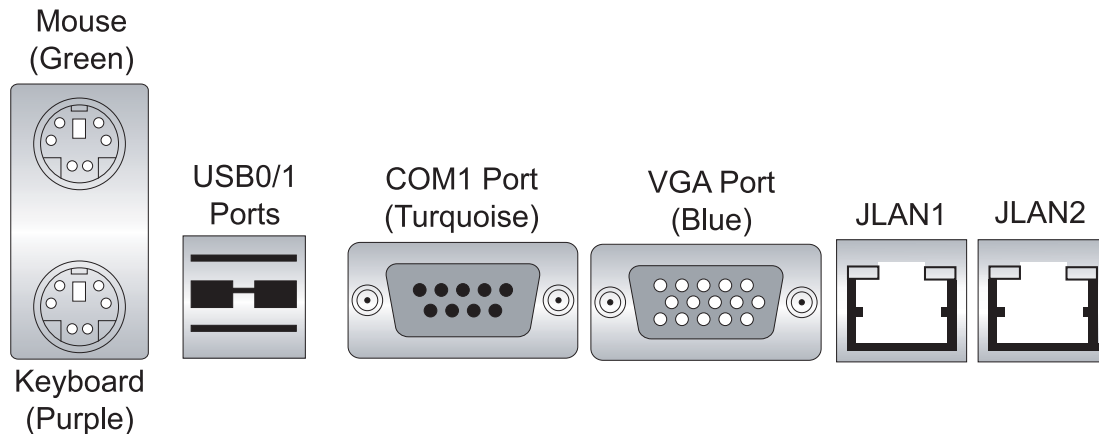

5-5 Installing Memory

Note: Check the Supermicro web site for recommended memory modules.

CAUTION!

Exercise extreme care when installing or removing DIMM modules to prevent any possible damage. Also note that the memory is interleaved to improve performance (see step 1).

1. Insert each memory module vertically into its slot, paying attention to the notch along the bottom of the module to prevent inserting the module incorrectly (see Figure 5-5). See support information below.
2. Gently press down on the memory module until it snaps into place.

Note: each processor has its own built-in memory controller, so the CPU2 DIMMs cannot be addressed if only a single CPU is installed. 128 MB, 256 MB, 512 MB, 1 GB and 2 GB memory modules are supported. It is highly recommended that you remove the power cord from the system before installing or changing DIMMs.

Support

The H8DM8-2/H8DME-2 supports single or dual-channel, DDR2-667/533/400 registered ECC SDRAM.

Both interleaved and non-interleaved memory are supported, so you may populate any number of DIMM slots (see note on previous page and charts on following page). The CPU2 DIMM slots can only be accessed when two CPUs are installed (however, the CPU2 DIMM slots are not required to be populated when two CPUs are installed).

Populating two adjacent slots at a time with memory modules of the same size and type will result in interleaved (128-bit) memory, which is faster than non-interleaved (64-bit) memory. See charts on following page.

Optimizing memory performance

If two processors are installed, it is better to stagger pairs of DIMMs across both sets of CPU DIMM slots, e.g. first populate CPU1 slots 1A and 1B, then CPU2 slots 1A, and 1B, then the next two CPU1 slots, etc. This balances the load over both CPUs to optimize performance.

Maximum memory: 32 GB of registered ECC DDR2-667/533 or 64 GB of registered ECC DDR2-400. If only one CPU is installed, maximum supported memory is halved.

Figure 5-5. Installing DIMM into Slot

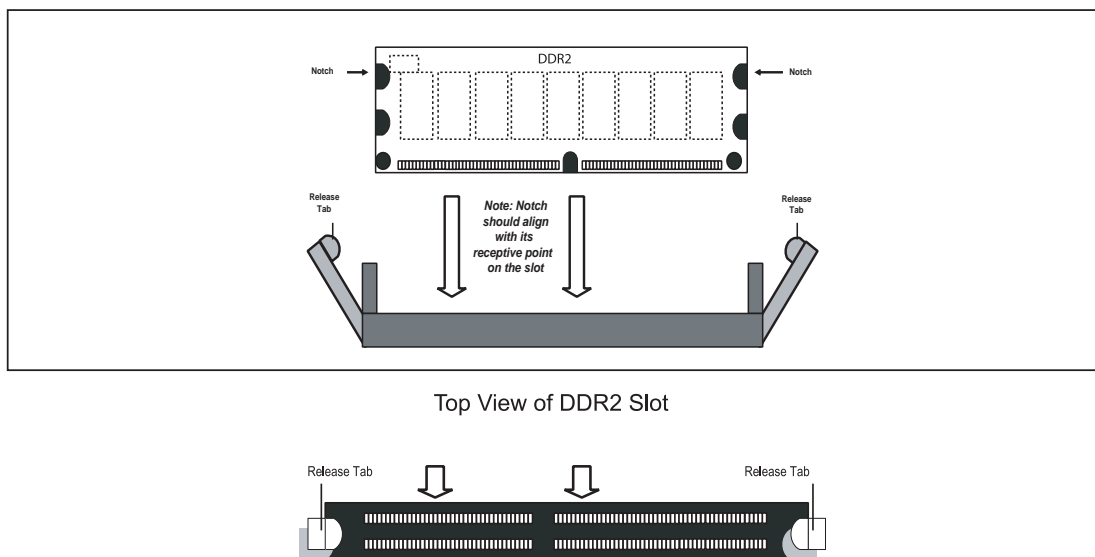

To Install: Insert module vertically and press down until it snaps into place. Pay attention to the bottom notches.

To Remove: Use your thumbs to gently push each release tab outward to free the DIMM from the slot.

Populating Memory Banks for 128-bit Operation							
CPU1 DIMM1A	CPU1 DIMM1B	CPU1 DIMM2A	CPU1 DIMM2B	CPU2 DIMM1A	CPU2 DIMM1B	CPU2 DIMM2A	CPU2 DIMM2B
X	X						
X	X			X	X		
X	X					X	X
X	X			X	X	X	X
X	X	X	X				
X	X	X	X	X	X		
X	X	X	X			X	X
X	X	X	X	X	X	X	X
		X	X				
		X	X	X	X		
		X	X			X	X
		X	X	X	X	X	X

Notes: X indicates a populated DIMM slot. If adding at least four DIMMs (with two CPUs installed), the configurations with DIMMs spread over both CPUs (and not like the configuration in row 5) will result in optimized performance. Note that the first two DIMMs must be installed in the CPU1 memory slots.

Populating Memory Banks for 64-bit Operation							
CPU1 DIMM1A	CPU1 DIMM1B	CPU1 DIMM2A	CPU1 DIMM2B	CPU2 DIMM1A	CPU2 DIMM1B	CPU2 DIMM2A	CPU2 DIMM2B
X							
		X					
X		X					
X				X			
X						X	
		X		X			
		X				X	

5-6 Adding PCI Cards

1. PCI slots

The H8DME-2/H8DM8-2 has six PCI expansion slots, which includes two PCI-Express x8 slots, two 64-bit 133 MHz PCI-X slots and two 64-bit 100 MHz PCI-X slots. On the H8DM8-2, one 100 MHz PCI-X slot supports Zero Channel RAID (ZCR). The 2021M-T2R+/2021M-82R+ can support low-profile cards in all six slots of the serverboard.

2. PCI card installation

Before installing a PCI add-on card, make sure you install it into a slot that supports the speed of the card (see step 1, above). After gaining access to the inside of the server, determine which slot you wish to populate, then press down on the curved section at the top of the blue tab for that slot. While pressing down, lift the tab to unlock the shield. Insert the expansion card into the correct slot on the serverboard, pushing down with your thumbs evenly on both sides of the card. Lock the card into place by pressing down on the tab. Follow this procedure when adding a card to other slots.

5-7 Serverboard Details

Figure 5-6. H8DM8-2/H8DME-2 Serverboard Layout
(not drawn to scale)

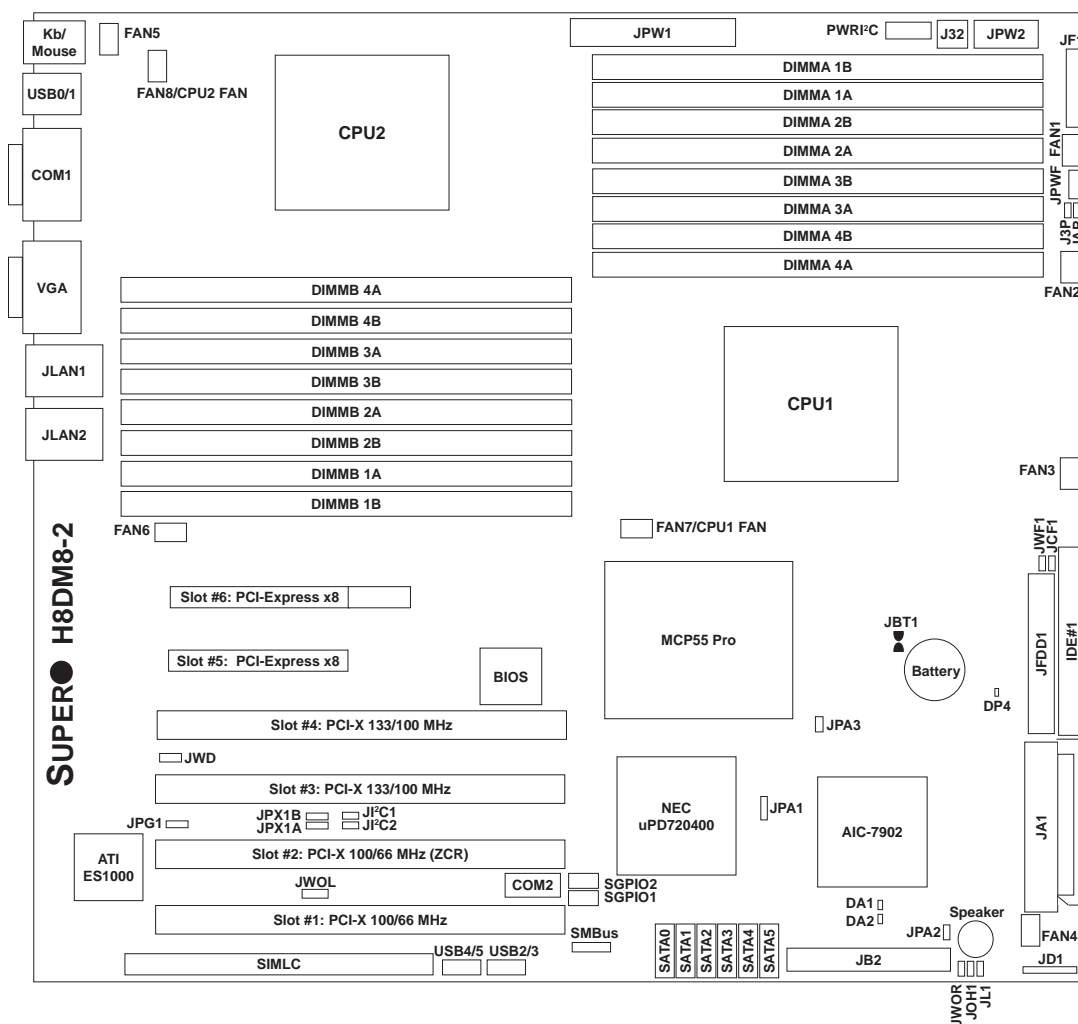

Notes:

1. Jumpers not indicated are for test purposes only.
2. The H8DME-2 has the same layout as the H8DM8-2 but with no SCSI components, connectors or jumpers.

H8DM8-2/H8DME-2 Quick Reference

Jumpers	Description	Default Setting
J3P	3rd Power Fail Detect En/Dis	Closed (Enabled)
JBT1	CMOS Clear	See Section 5-9
JCF1	Compact Flash Master/Slave	Closed (Master)
JI ² C1/2	I ² C to PCI Enable/Disable	Closed (Enabled)
JPA1*	SCSI Enable/Disable	Pins 1-2 (Enabled)
JPA2/JPA3*	SCSI Channel A/B Term.	Open (Enabled)
JPG1	VGA Enable/Disable	Pins 1-2 (Enabled)
JPX1A/JPX1B	PCI-X Slot #1&2/3&4 Freq.	Open (Auto)
JWD	Watch Dog	Pins 1-2 (Reset)

Connectors	Description
COM1, COM2	COM1/COM2 Serial Port/Header
FAN 1-8	System Fan Headers
IDE#1	IDE Drive Connector
J32	4-pin Auxiliary Power Connector
JA1/JB2*	U320 SCSI Channel A/Channel B Connector
JAR	Power Fail Alarm Reset Header
JD1	Onboard Speaker/Keylock/Power LED
JF1	Front Panel Connector
JFDD1	Floppy Disk Drive Connector
JL1	Chassis Intrusion Header
JLAN1/2	Gigabit Ethernet (RJ45) Ports
JOH1	Overheat Warning Header
JPW1	24-Pin ATX Power Connector
JPW2	8-Pin Processor Power Connector
JPWF	3rd Power Supply Alarm Header
JWF1	Compact Flash Card Power Connector
JWOL	Wake-On-LAN Header
JWOR	Wake-On-Ring Header
PWRI ² C	Power Supply I ² C Header
SATA0 ~ SATA5	Serial ATA Connectors
SGPIO1/SGPIO2	SGPIO Headers
SIMLC	IPMI 2.0 Card Slot
SMBus	System Management Bus Header
USB0/1	Universal Serial Bus (USB) Ports 0/1
USB2/3, USB4/5	USB Headers

Indicators	Description
DP1	Onboard Power LED
DA1/DA2*	SCSI Channel A/B Activity LED

*H8DM8-2 only

5-8 Connecting Cables

ATX Power Connector

The primary ATX power supply connector (JPW1) meets the SSI (Super-set ATX) 24-pin specification. Refer to the table on the right for the pin definitions of the ATX 24-pin power connector. This connection supplies power to the chipset, fans and memory.

Note: You must also connect the 8-pin (JPW2) and 4-pin (J32) power connectors to your power supply (see below).

ATX Power 24-pin Connector Pin Definitions (JPW1)			
Pin#	Definition	Pin #	Definition
13	+3.3V	1	+3.3V
14	-12V	2	+3.3V
15	COM	3	COM
16	PS_ON	4	+5V
17	COM	5	COM
18	COM	6	+5V
19	COM	7	COM
20	Res (NC)	8	PWR_OK
21	+5V	9	5VSB
22	+5V	10	+12V
23	+5V	11	+12V
24	COM	12	+3.3V

Processor Power Connector

In addition to the primary ATX power connector (above), the 12v, 8-pin processor power connector at JPW2 must also be connected to your power supply. This connection supplies power to the CPUs. See the table on the right for pin definitions.

Processor Power Connector Pin Definitions (JPW2)	
Pins	Definition
1 through 4	Ground
5 through 8	+12V

Required Connection

Auxiliary Power Connector

The 4-pin auxiliary power connector at J32 must also be connected to your power supply. This connection supplies extra power that may be needed for high loads. See the table on the right for pin definitions.

Auxiliary Power Connector Pin Definitions (J32)	
Pins	Definition
1 & 2	Ground
3 & 4	+12V

Required Connection

Power LED

The Power LED connection is located on pins 15 and 16 of JF1. Refer to the table on the right for pin definitions.

Power LED Pin Definitions (JF1)	
Pin#	Definition
15	Vcc
16	Control

HDD LED

The HDD (IDE Hard Disk Drive) LED connection is located on pins 13 and 14 of JF1. Attach the IDE hard drive LED cable to display disk activity. Refer to the table on the right for pin definitions.

HDD LED Pin Definitions (JF1)	
Pin#	Definition
13	Vcc
14	HD Active

NIC1 LED

The NIC1 (Network Interface Controller) LED connection is located on pins 11 and 12 of JF1. Attach the NIC1 LED cable to display network activity. Refer to the table on the right for pin definitions.

NIC1 LED Pin Definitions (JF1)	
Pin#	Definition
11	Vcc
12	NIC1 Active

NIC2 LED

The NIC2 (Network Interface Controller) LED connection is located on pins 9 and 10 of JF1. Attach the NIC2 LED cable to display network activity. Refer to the table on the right for pin definitions.

NIC2 LED Pin Definitions (JF1)	
Pin#	Definition
9	Vcc
10	NIC2 Active

Overheat/Fan Fail LED

Connect an LED to the OH connection on pins 7 and 8 of JF1 to provide advanced warning of chassis overheating. Refer to the table on the right for pin definitions and status indicators.

OH/Fan Fail LED Pin Definitions (JF1)		OH/Fan Fail LED Status	
Pin#	Definition	State	Indication
7	Vcc	Solid	Overheat
8	Control	Blinking	Fan fail

Power Fail LED

The Power Fail LED connection is located on pins 5 and 6 of JF1. Refer to the table on the right for pin definitions. This feature is only available for systems with redundant power supplies.

Power Fail LED Pin Definitions (JF1)	
Pin#	Definition
5	Vcc
6	Control

Reset Button

The Reset Button connection is located on pins 3 and 4 of JF1. Attach it to the hardware reset switch on the computer case. Refer to the table on the right for pin definitions.

Reset Button Pin Definitions (JF1)	
Pin#	Definition
3	Reset
4	Ground

Power Button

The Power Button connection is located on pins 1 and 2 of JF1. Momentarily contacting both pins will power on/off the system. This button can also be configured to function as a suspend button (see the Power Button Mode setting in BIOS). To turn off the power when set to suspend mode, depress the button for at least 4 seconds. Refer to the table on the right for pin definitions.

Power Button Pin Definitions (JF1)	
Pin#	Definition
1	PW_ON
2	Ground

Universal Serial Bus Ports (USB0/1)

Two Universal Serial Bus ports (USB2.0) are located beside the JLAN1/2 ports. See the table on the right for pin definitions.

Universal Serial Bus Ports Pin Definitions (USB0/1)			
USB0		USB1	
Pin #	Definition	Pin #	Definition
1	+5V	1	+5V
2	PO-	2	PO-
3	PO+	3	PO+
4	Ground	4	Ground

USB Headers

Four additional USB2.0 headers (USB2/3 and USB4/5) are included on the serverboard. These may be connected to provide front side access. A USB cable (not included) is needed for the connection. See the table on the right for pin definitions.

Universal Serial Bus Headers Pin Definitions (USB2/3/4/5)			
USB2		USB3/4	
Pin #	Definition	Pin #	Definition
1	+5V	1	+5V
2	PO-	2	PO-
3	PO+	3	PO+
4	Ground	4	Ground
5	Key	5	No connection

ATX PS/2 Keyboard and PS/2 Mouse Ports

The ATX PS/2 keyboard and the PS/2 mouse ports are located on the IO backplane. The mouse is the top (green) port. See the table on the right for pin definitions.

PS/2 Keyboard and Mouse Port Pin Definitions	
Pin#	Definition
1	Data
2	NC
3	Ground
4	VCC
5	Clock
6	NC

Serial Ports

The COM1 and COM2 serial ports are located under the parallel port. Refer to the serverboard layout for locations and the table on the right for pin definitions.

Serial Port Pin Definitions (COM1/COM2)			
Pin #	Definition	Pin #	Definition
1	DCD	6	DSR
2	RXD	7	RTS
3	TXD	8	CTS
4	DTR	9	RI
5	Ground	10	NC

Note: NC indicates no connection.

Fan Headers

The H8DM8-2/H8DME-2 has eight fan headers, which are designated FAN1 through FAN8. Fans are Pulse Width Modulated (PWM) and their speed is controlled via Thermal Management with a BIOS setting. See the table on the right for pin definitions.

Note: when using active heatsinks (those with fans), connect the heatsink fan for CPU1 to the FAN7 header and the heatsink fan for CPU2 to the FAN8 header.

Fan Header Pin Definitions (FAN1-8)	
Pin#	Definition
1	Ground (Black)
2	+12V (Red)
3	Tachometer
4	PWM Control

JLAN1/2 (Ethernet Ports)

Two Gigabit Ethernet ports (designated JLAN1 and JLAN2) are located beside the COM2 port. These Ethernet ports accept RJ45 type cables.



Notes: JLAN1 is the top port and JLAN2 is the bottom port.

Power LED/Speaker

On JD1, pins 1, 2, and 3 are for the power LED and pins 4 through 7 are for the speaker. See the tables on the right for pin definitions.

Note: The speaker connector pins are for use with an external speaker. If you wish to use the onboard speaker, you should close pins 6 and 7 with a jumper.

PWR LED Connector Pin Definitions (JD1)	
Pin#	Definition
1	+Vcc
2	Control
3	Control

Speaker Connector Pin Definitions (JD1)	
Pin#	Definition
4	Red wire, +5V
5	No connection
6	Buzzer signal
7	Speaker data

Overheat LED

Connect an LED to the JOH1 header to provide warning of chassis overheating. See the table on the right for pin definitions.

Overheat LED Pin Definitions (JOH1)	
Pin#	Definition
1	3.3V
2	OH Active

Chassis Intrusion

A Chassis Intrusion header is located at JL1. Attach the appropriate cable to inform you of a chassis intrusion.

Chassis Intrusion Pin Definitions (JL1)	
Pin#	Definition
1	Battery voltage
2	Intrusion signal

Wake-On-LAN

The Wake-On-LAN header is designated JWOL. See the table on the right for pin definitions. You must have a LAN card with a Wake-On-LAN connector and cable to use the Wake-On-LAN feature.

(Note: Wake-On-LAN from S3, S4, S5 are supported by LAN1. LAN2 supports Wake-On-LAN from S1 only.)

Wake-On-LAN Pin Definitions (JWOL)	
Pin#	Definition
1	+5V Standby
2	Ground
3	Wake-up

Wake-On-Ring

The Wake-On-Ring header is designated JWOR. This function allows your computer to receive and "wake-up" by an incoming call to the modem when in suspend state. See the table on the right for pin definitions. You must have a Wake-On-Ring card and cable to use this feature.

Wake-On-Ring Pin Definitions (JWOR)	
Pin#	Definition
1	Ground (Black)
2	Wake-up

Power Supply I²C Header

The PWRI²C header is for I²C, which may be used to monitor the status of the power supply, fans and system temperature. See the table on the right for pin definitions.

I ² C Header Pin Definitions (PWRI ² C)	
Pin#	Definition
1	Clock
2	Data
3	PWR Fail
4	Gnd
5	+3.3V

SMBus Header

The header at SMBus is for the System Management Bus. Connect the appropriate cable here to utilize SMB on the system. See the table on the right for pin definitions.

SMBus Header Pin Definitions (SMBus)	
Pin#	Definition
1	Data
2	Ground
3	Clock
4	No Connection

3rd Power Supply Alarm Header

Connect a cable from your power supply to JPWF to provide you with warning of a power supply failure. The warning signal is passed through the PWR_LED pin to indicate a power failure. See the table on the right for pin definitions.

3rd Power Supply Alarm Header Pin Definitions (JPWF)	
Pin#	Definition
1	P/S 1 Fail Signal
2	P/S 2 Fail Signal
3	P/S 3 Fail Signal
4	Reset (from MB)

Note: This feature is only available when using redundant power supplies.

Power Fail Alarm Reset Header

Connect JAR to the alarm reset button on your chassis (if available) or to a microswitch to allow you to turn off the alarm that sounds when a power supply module fails. See the table on the right for pin definitions.

Alarm Reset Header Pin Definitions (JAR)	
Pin#	Definition
1	Ground
2	Reset Signal

Compact Flash Power Header

A Compact Flash Card Power header is located at JWF1. For the Compact Flash Card to work properly, you will first need to connect the device's power cable to JWF1 and correctly set the Compact Flash Jumper (JCF1).

Compact Flash Power Header Pin Definitions (JWF1)	
Pin#	Definition
1	+5V
2	Ground
3	Signal

SGPIO

SGPIO1 and SGPIO2 (Serial General Purpose Input/Output) provide a bus between the SATA controller and the SATA drive backplane to provide SATA enclosure management functions. Connect the appropriate cables from the backplane to the SGPIO1 and SGPIO2 header(s) to utilize SATA management functions on your system.

SGPIO Header Pin Definitions (SGPIO1, SGPIO2)			
Pin#	Definition	Pin #	Definition
1	NC	2	NC
3	Ground	4	Data
5	Load	6	Ground
7	NC	8	NC

Note: NC indicates no connection.

5-9 Jumper Settings

Explanation of Jumpers

To modify the operation of the serverboard, jumpers can be used to choose between optional settings. Jumpers create shorts between two pins to change the function of the connector. Pin 1 is identified with a square solder pad on the printed circuit board. See the diagram at right for an example of jumping pins 1 and 2. Refer to the serverboard layout page for jumper locations.

Note: On two-pin jumpers, "Closed" means the jumper is on and "Open" means the jumper is off the pins.

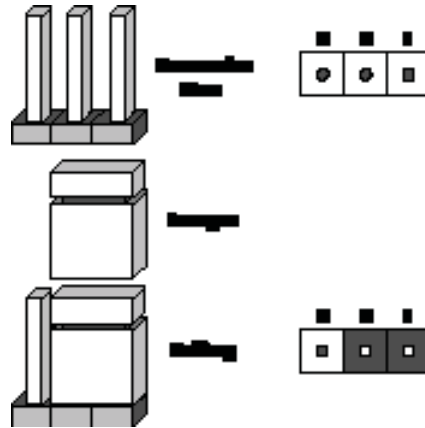

CMOS Clear

JBT1 is used to clear CMOS and will also clear any passwords. Instead of pins, this jumper consists of contact pads to prevent accidentally clearing the contents of CMOS.

To clear CMOS,

- 1) First power down the system and unplug the power cord(s).
- 2) With the power disconnected, short the CMOS pads with a metal object such as a small screwdriver for at least four seconds.
- 3) Remove the screwdriver (or shorting device).
- 4) Reconnect the power cord(s) and power on the system.

Notes:

Do not use the PW ON connector to clear CMOS.

The onboard battery does not need to be removed when clearing CMOS, however you must short JBT1 for at least four seconds.



JBT1 contact pads

3rd Power Supply Fail Detect Enable/Disable

The system can notify you in the event of a power supply failure. This feature assumes that three redundant power supply units are installed in the chassis. If you only have one or two power supplies installed, you should disable the function with the J3P header to prevent false alarms. See the table on the right for jumper settings.

3rd Power Supply Fail Detect Jumper Settings (J3P)	
Jumper Setting	Definition
Open	Disabled
Closed	Enabled

I²C to PCI Enable/Disable

The JI²C1/2 pair of jumpers allows you to connect the System Management Bus to the PCI expansion slots. The default setting is closed (on) for both jumpers to enable the connection. Both connectors must be set the same (JI²C1 is for data and JI²C2 is for the clock). See the table on right for jumper settings.

I ² C to PCI Enable/Disable Jumper Settings (JI ² C1/2)	
Jumper Setting	Definition
Closed	Enabled
Open	Disabled

Watch Dog

JWD controls Watch Dog, a system monitor that takes action when a software application freezes the system. Jumping pins 1-2 will cause WD to reset the system if an application is hung up. Jumping pins 2-3 will generate a non-maskable interrupt signal for the application that is hung up. See the table on the right for jumper settings. Watch Dog can also be enabled via BIOS.

Watch Dog Jumper Settings (JWD)	
Jumper Setting	Definition
Pins 1-2	Reset
Pins 2-3	NMI
Open	Disabled

Note: When enabled, the user needs to write their own application software in order to disable the Watch Dog timer.

Onboard Speaker Enable/ Disable

The JD1 header allows you to use either an external speaker or the internal (onboard) speaker. To use the internal onboard speaker, close pins 6 and 7 with a jumper. To use an external speaker, remove the jumper and connect the speaker wires to pins 4 (+5V) and 7 (control signal). See the table on the right for settings and the table associated with the Power LED/Keylock/Speaker connection (previous section) for jumper settings.

Onboard Speaker Enable/Disable Pin Definitions (JD1)	
Pins	Definition
6 and 7	Jump for onboard speaker
4 and 7	Attach external speaker wires

Note: Pins 4-7 are used only for the onboard speaker.

PCI-X Slot Speed

Jumpers JPX1A and JPX1B on the H8DM8-2/H8DME-2 can be used to change the speed of PCI-X slots #1&2 and PCI-X slots #3&4, respectively. See the tables on the right for jumper settings.

Note: JPX1A controls the speed for PCI-X slots #1 and #2. JPX1B controls the speed for PCI-X slots #3 and #4. The default setting for both is Auto.

PCI-X Slot Speed Jumper Settings (JPX1A/JPX1B)	
Jumper Setting	Definition
Open	Auto
Pins 1-2	PCI-X 66 MHz
Pins 2-3	PCI 66 MHz

SCSI Controller Enable/ Disable (H8DM8-2 only)

Jumper JPA1 is used to enable or disable the onboard SCSI controller. The default setting is on pins 1-2 to enable SCSI. See the table on right for jumper settings.

SCSI Enable/Disable Jumper Settings (JPA1)	
Jumper Setting	Definition
Pins 1-2	Enabled
Pins 2-3	Disabled

SCSI Termination Enable/ Disable (H8DM8-2 only)

Jumpers JPA2 and JPA3 are used to enable or disable termination for the SCSI Channel A and B connector, respectively. The default setting is open to enable termination. See the table on right for jumper settings.

Note: In order for the SCSI drives to function properly, please do not change the default setting (enabled) set by the manufacturer.)

SCSI Term. Enable/Disable Jumper Settings (JPA2, JPA3)	
Jumper Setting	Definition
Open	Enabled
Closed	Disabled

VGA Enable/Disable

JPG1 allows you to enable or disable the VGA port. The default position is on pins 1 and 2 to enable VGA. See the table on the right for jumper settings.

VGA Enable/Disable Jumper Settings (JPG1)	
Jumper Setting	Definition
Pins 1-2	Enabled
Pins 2-3	Disabled

Compact Flash Master/Slave

The JCF1 jumper allows you to assign either master or slave status a compact flash card installed in IDE1. See the table on the right for jumper settings.

Compact Flash Master/Slave Jumper Settings (JCF1)	
Jumper Setting	Definition
Closed	Master
Open	Slave

5-10 Onboard Indicators

JLAN1/JLAN2 LEDs

The Ethernet ports (located beside the VGA port) have two LEDs. On each Gb LAN port, one LED indicates activity when blinking while the other LED may be amber or off to indicate the speed of the connection. See the table on the right for the functions associated with the connection speed LED.

JLAN LED (Connection Speed Indicator)	
LED Color	Definition
Off	10/100 Mb/s
Amber	1 Gb/s

+3.3V Standby LED

When illuminated, the DP4 LED indicates that +3.3V standby power from the power supply is being supplied to the serverboard. DP4 should normally be illuminated when the system is connected to AC power, whether turned on or not. DP4 will flash on and off when the system is in an S1, S3 (Suspend to RAM) or S4 (Suspend to Disk) state. See the table on the right for DP4 LED states.

+3.3V Standby LED (DP4)	
State	System Status
On	Standby power present on serverboard
Off	No power connected
Flashing	System in standby state

SCSI Activity LEDs (H8DM8-2 only)

When illuminated, the DA1 and DA2 LEDs indicate activity on SCSI channels A and B, respectively. These LEDs are located near the SCSI controller chip. See the table on the right for LED states.

SCSI Activity LEDs (DA1, DA2)	
State	System Status
On	SCSI channel active
Off	SCSI channel inactive

5-11 Floppy, IDE, SCSI and SATA Drive Connections

Use the following information to connect the floppy and hard disk drive cables.

- The floppy disk drive cable has seven twisted wires.
- A red mark on a wire typically designates the location of pin 1.
- A single floppy disk drive ribbon cable has 34 wires and two connectors to provide for two floppy disk drives. The connector with twisted wires always connects to drive A, and the connector that does not have twisted wires always connects to drive B.
- The 80-wire ATA133 IDE hard disk drive cable that came with your system has two connectors to support two drives. This special cable should be used to take advantage of the speed this new technology offers. The blue connector connects to the onboard IDE connector interface and the other connector(s) to your hard drive(s). Consult the documentation that came with your disk drive for details on actual jumper locations and settings for the hard disk drive.

Floppy Connector

The floppy connector is located beside the IDE connector. See the table on the right for pin definitions.

Floppy Drive Connector Pin Definitions (JFDD1)			
Pin#	Definition	Pin #	Definition
1	GND	2	FDHDIN
3	GND	4	Reserved
5	Key	6	FDEDIN
7	GND	8	Index-
9	GND	10	Motor Enable
11	GND	12	Drive Select B-
13	GND	14	Drive Select A-
15	GND	16	Motor Enable
17	GND	18	DIR-
19	GND	20	STEP-
21	GND	22	Write Data-
23	GND	24	Write Gate-
25	GND	26	Track 00-
27	GND	28	Write Protect-
29	GND	30	Read Data-
31	GND	32	Side 1 Select-
33	GND	34	Diskette

IDE Connector

There are no jumpers to configure the onboard IDE#1 connector unless using it for a compact flash device. See the table on the right for pin definitions.

IDE Drive Connectors Pin Definitions (IDE#1)			
Pin#	Definition	Pin #	Definition
1	Reset IDE	2	Ground
3	Host Data 7	4	Host Data 8
5	Host Data 6	6	Host Data 9
7	Host Data 5	8	Host Data 10
9	Host Data 4	10	Host Data 11
11	Host Data 3	12	Host Data 12
13	Host Data 2	14	Host Data 13
15	Host Data 1	16	Host Data 14
17	Host Data 0	18	Host Data 15
19	Ground	20	Key
21	DRQ3	22	Ground
23	I/O Write	24	Ground
25	I/O Read	26	Ground
27	IOCHRDY	28	BALE
29	DACK3	30	Ground
31	IRQ14	32	IOCS16
33	Addr1	34	Ground
35	Addr0	36	Addr2
37	Chip Select 0	38	Chip Select 1
39	Activity	40	Ground

SATA Ports

There are no jumpers to configure the SATA ports, which are designated SATA0 through SATA5. See the table on the right for pin definitions.

SATA Drive Ports Pin Definitions (SATA0-SATA5)	
Pin #	Definition
1	Ground
2	TXP
3	TXN
4	Ground
5	RXN
6	RXP
7	Ground

SCSI Connectors (H8DM8-2 only)

Refer to the table at right for pin definitions for the Ultra320 SCSI connectors located at JA1 and JB2.

Ultra320 SCSI Drive Connectors Pin Definitions (JA1/JB2)			
Pin#	Definition	Pin #	Definition
1	+DB (12)	35	-DB (12)
2	+DB (13)	36	-DB (13)
3	+DB (14)	37	-DB (14)
4	+DB (15)	38	-DB (15)
5	+DB (P1)	39	-DB (P1)
6	+DB (0)	40	-DB (0)
7	+DB (1)	41	-DB (1)
8	+DB (2)	42	-DB (2)
9	+DB (3)	43	-DB (3)
10	+DB (4)	44	-DB (4)
11	+DB (5)	45	-DB (5)
12	+DB (6)	46	-DB (6)
13	+DB (7)	47	-DB (7)
14	+DB (P)	48	-DB (P)
15	Ground	49	Ground
16	DIFFSENS	50	Ground
17	TERMPWR	51	TERMPWR
18	TERMPWR	52	TERMPWR
19	Reserved	53	Reserved
20	Ground	54	Ground
21	+ATN	55	-ATN
22	Ground	56	Ground
23	+BSY	57	-BSY
24	+ACK	58	-ACK
25	+RST	59	-RST
26	+MSG	60	-MSG
27	+SEL	61	-SEL
28	+C/D	62	-C/D
29	+REQ	63	-REQ
30	+I/O	64	-I/O
31	+DB (8)	65	-DB (8)
32	+DB (9)	66	-DB (9)
33	+DB (10)	67	-DB (10)
34	+DB (11)	68	-DB (11)

5-12 Enabling SATA RAID

Now that the hardware is set up, you must now install the operating system and the SATA RAID drivers, if you wish to use RAID with your SATA drives. The installation procedure differs depending on whether you wish to have the operating system installed on a RAID array or on a separate non-RAID drive. See the instructions below for details.

Serial ATA (SATA)

Serial ATA (SATA) is a physical storage interface that employs a single cable with a minimum of four wires to create a point-to-point connection between devices. This connection is a serial link that supports a SATA transfer rate from 150 MBps. The serial cables used in SATA are thinner than the traditional cables used in Parallel ATA (PATA) and can extend up to one meter in length, compared to only 40 cm for PATA cables. Overall, SATA provides better functionality than PATA.

Installing the OS/SATA Driver

Before installing the OS (operating system) and SATA RAID driver, you must decide if you wish to have the operating system installed as part of a bootable RAID array or installed to a separate non-RAID hard drive. If on a separate drive, you may install the driver either during or after the OS installation. If you wish to have the OS on a SATA RAID array, you must follow the procedure below and install the driver during the OS installation.

Building a Driver Diskette

You must first build a driver diskette from the Supermicro CD-ROM that was included with the system. (You will have to create this disk on a computer that is already running and with the OS installed.) Insert the CD into your CD-ROM drive and start the system. A display as shown in Figure 2-5 will appear. Click on the icon labeled "Build Driver Diskettes and Manuals" and follow the instructions to create a floppy disk with the driver on it. Once it's been created, remove the floppy and insert the installation CD for the Windows Operating System you wish to install into the CD-ROM drive of the new system you are about to configure.

Enabling SATA RAID in the BIOS

Before installing the Windows Operating System, you must change some settings in BIOS. Boot up the system and hit the key to enter the BIOS Setup Utility. After the Setup Utility loads,

1. Use the arrow keys to move to the Exit menu. Scroll down with the arrow keys to the "Load Optimal Defaults setting and press <Enter>. Select "OK" to confirm, then <Enter> to load the default settings.

2. Use the arrow keys to move to Advanced > Floppy/IDE/SATA Configuration > nVidia RAID Setup and press the <Enter> key. Once in the submenu, enable the "nVidia RAID Function" setting, which will cause the SATA0/1/2 Primary/Secondary settings to appear. Enable the SATA devices and channels you will be using.
3. Hit the <Esc> key twice and scroll to the Exit menu. Select "Save Changes and Exit" and hit <enter>, then hit <Enter> again to verify.
4. After exiting the BIOS Setup Utility, the system will reboot. When prompted during the startup, press the <F10> key when prompted to run the nVidia RAID Utility program.

Using the nVidia RAID Utility

The nVidia RAID Utility program is where you can define the drives you want to include in the RAID array and the mode and type of RAID. Two main windows are shown in the utility. The "Free Disks" window on the left will list all available drives. Use the arrow keys to select and move drives to the window on the right, which lists all drives that are to become part of the RAID array.

Once you have finished selecting the drives and type of RAID you wish to use for your RAID array, press the <F7> key. You will be prompted to verify your choice; if you want to continue with your choices, select "Yes". Note that selecting "Yes" will clear all previous data from the drives you selected to be a part of the array. You are then given the choice of making the RAID array bootable by pressing the the key. After you have finished, press the <Ctrl> and <X> keys simultaneously.

Installing the OS and Drivers

With the Windows OS installation CD in the CD-ROM drive, restart the system. When you see the prompt, hit the <F6> key to enter Windows setup. Eventually a blue screen will appear with a message that begins "Windows could not determine the type of one or more storage devices . . ." When you see the screen, hit the <S> key to "Specify Additional Device", then insert the driver diskette you just created into the floppy drive. Highlight "Manufacturer Supplied Hardware Support Disk" and hit the <Enter> key. Highlight the first "nVidia RAID" driver shown and press the <Enter> key to install it. Soon a similar blue screen will appear again. Again hit the <S> key, then highlight the second item, "nForce Storage Controller" and press the <Enter> key, then <Enter> again to continue with the Windows setup.

5-13 Installing Additional Drivers

The CD that came bundled with the system contains software drivers, some of which must be installed, such as the chipset driver. After inserting this CD into your CD-ROM drive, the display shown in Figure 5-7 should appear. (If this display does not appear, click on the My Computer icon and then on the icon representing your CD-ROM drive. Finally, double click on the S "Setup" icon.)

Figure 5-7. Driver/Tool Installation Display Screen

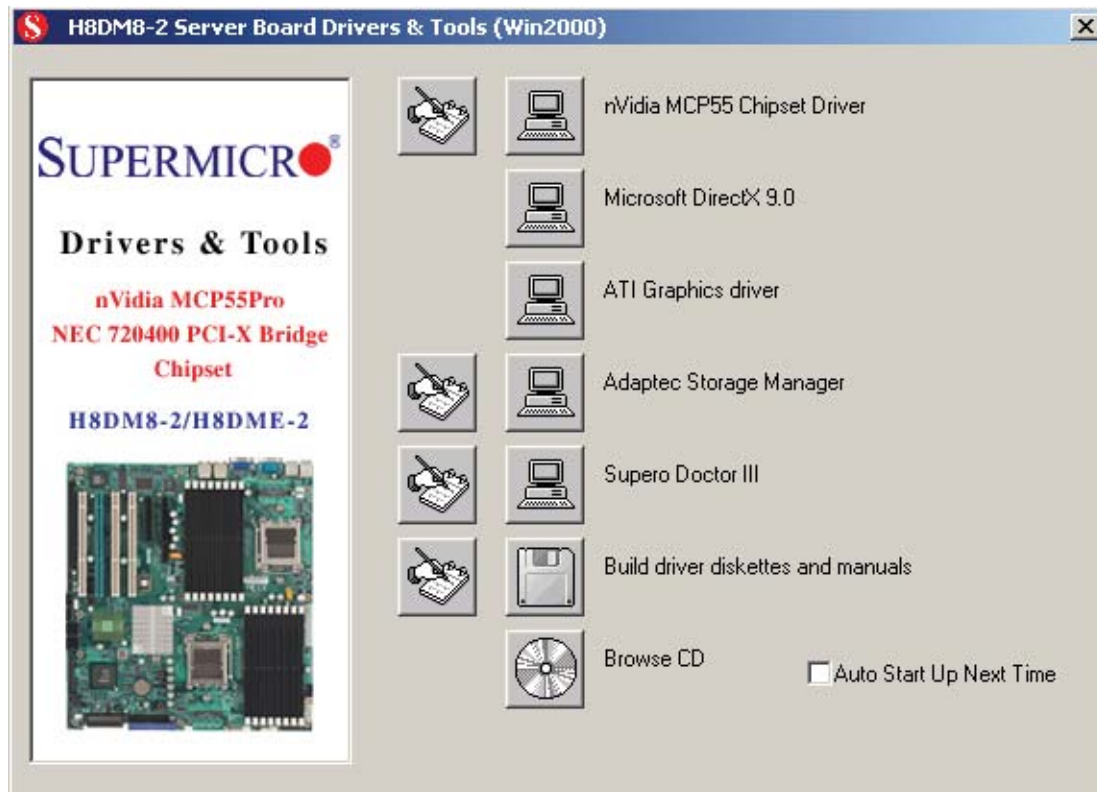

Click the icons showing a hand writing on paper to view the readme files for each item. Click the computer icons to the right of these items to install each item (from top to the bottom) one at a time. **After installing each item, you should reboot the system before moving on to the next item on the list.** The bottom icon with a CD on it allows you to view the entire contents of the CD.

Chapter 6

Advanced Chassis Setup

This chapter covers the steps required to install components and perform maintenance on the SC825TQ-R700LP/SC825S2-R700LP chassis. For component installation, follow the steps in the order given to eliminate the most common problems encountered. If some steps are unnecessary, skip ahead to the step that follows.

Tools Required

The only tool you will need to install components and perform maintenance is a Philips screwdriver.

6-1 Static-Sensitive Devices

Electrostatic discharge (ESD) can damage electronic components. To prevent damage to any printed circuit boards (PCBs), it is important to handle them very carefully. The following measures are generally sufficient to protect your equipment from ESD damage.

Precautions

- Use a grounded wrist strap designed to prevent static discharge.
- Touch a grounded metal object before removing any board from its antistatic bag.
- Handle a board by its edges only; do not touch its components, peripheral chips, memory modules or gold contacts.
- When handling chips or modules, avoid touching their pins.
- Put the serverboard, add-on cards and peripherals back into their antistatic bags when not in use.
- For grounding purposes, make sure your computer chassis provides excellent conductivity between the power supply, the case, the mounting fasteners and the serverboard.

Unpacking

The serverboard is shipped in antistatic packaging to avoid static damage. When unpacking the board, make sure the person handling it is static protected.

Figure 6-1. Front and Rear Chassis Views

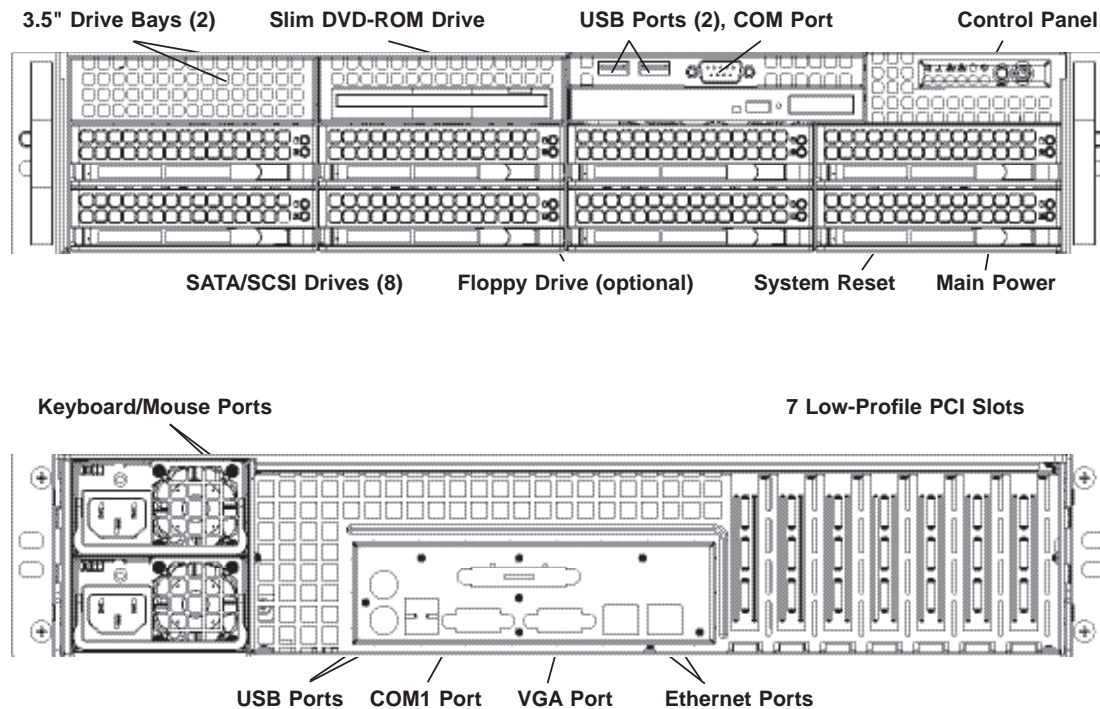

6-2 Control Panel

The control panel (located on the front of the chassis) must be connected to the JF1 connector on the serverboard to provide you with system status indications. A ribbon cable has bundled these wires together to simplify the connection. Connect the cable from JF1 on the serverboard to JP4 on the Control Panel PCB (printed circuit board). Make sure the red wire plugs into pin 1 on both JF1 and JP4. Pull all excess cabling out of the airflow path. The LEDs inform you of system status. See Chapter 3 for details on the LEDs and the control panel buttons. Details on JF1 can be found in Chapter 5.

6-3 System Fans

Three 8-cm hot-swap fans provide the cooling for the 2021M-T2R+/2021M-82R+. It is very important that the chassis top cover is properly installed and making a good seal in order for the cooling air to circulate properly through the chassis and cool the components. See Figure 6-2.

System Fan Failure

Fan speed is controlled by system temperature via a BIOS setting. If a fan fails, the remaining fans will ramp up to full speed and the overheat/fan fail LED on the control panel will turn on. Replace any failed fan at your earliest convenience with the same type and model (the system can continue to run with a failed fan). Remove the top chassis cover while the system is still running to determine which of the fans has failed.

Replacing System Fans

1. Removing a fan

Remove the chassis cover. Press the tabs on the sides of the fan to unlock and remove the fan and its housing. The fan's power connections will automatically detach. System power does not need to be shut down since the fans are hot-pluggable.

2. Installing a new fan

Replace the failed fan with an identical 8-cm, 12 volt fan (available from Supermicro, p/n FAN-0094L). Position the new fan into the space vacated by the failed fan previously removed. A "click" can be heard when the fan is fully installed in place and the power connections are made. If the system power is on, the hot-plug feature will cause the fan to start immediately upon being connected to its header on the serverboard.

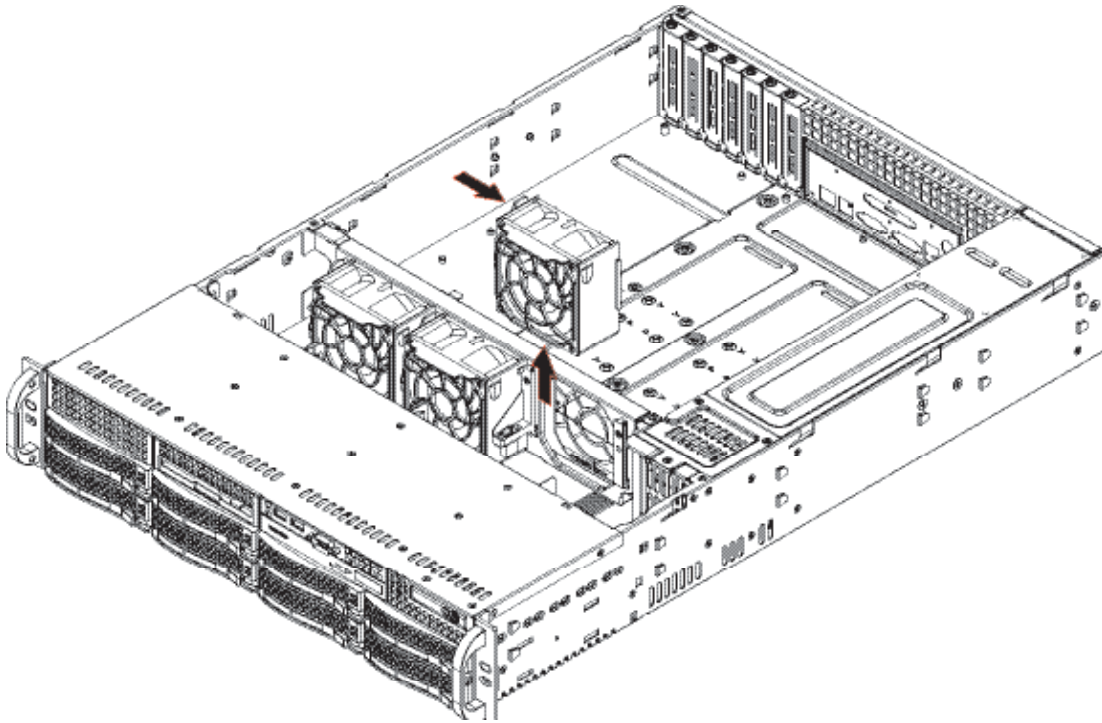
Figure 6-2. Removing System Cooling Fans

6-4 Drive Bay Installation/Removal

Accessing the Drive Bays

SATA/SCSI Drives: You do not need to access the inside of the chassis or remove power to replace or swap SATA/SCSI drives. Proceed to the next step for instructions. **Note:** You must use standard 1" high, SATA/SCSI drives in the 2021M-T2R+/2021M-82R+.

DVD-ROM/Floppy Disk Drive: For installing/removing the DVD-ROM or floppy disk drive, you will need to gain access to the inside of the server by removing the top cover of the chassis. Proceed to the "DVD-ROM and Floppy Drive Installation" section later in this chapter for instructions.

5.25" Drive Bay: For installing/removing a component in the 5.25" drive bay, proceed to the "5.25" Drive Bay Installation" section later in this chapter for instructions.

SATA/SCSI Drive Installation

1. Mounting a SATA/SCSI drive in a drive carrier

The SATA/SCSI drives are mounted in drive carriers to simplify their installation and removal from the chassis. These carriers also help promote proper airflow for the drives. For this reason, even empty carriers without SATA/SCSI drives installed must remain in the chassis. To add a new SATA/SCSI drive, install a drive into the carrier with the printed circuit board side facing down so that the mounting holes align with those in the carrier. Secure the drive to the carrier with four screws, as shown in Figure 6-3.

Figure 6-3. Mounting a SATA/SCSI Drive in a Carrier

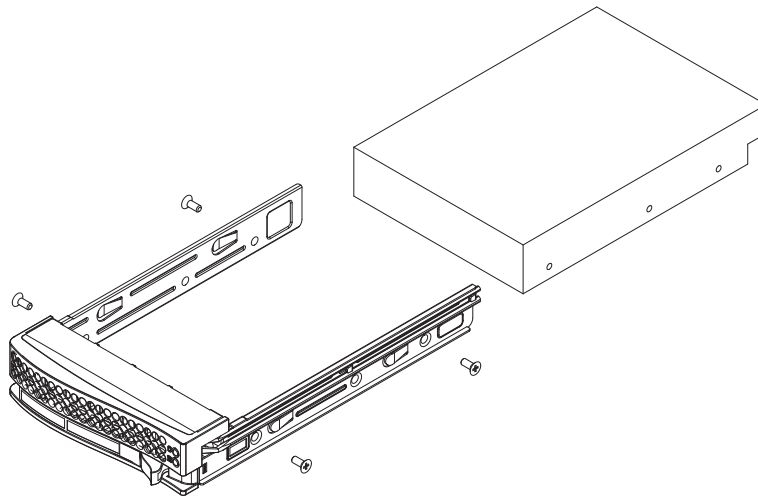

Use caution when working around the SATA/SCSI backplane. Do not touch the backplane with any metal objects and make sure no ribbon cables touch the backplane or obstruct the holes, which aid in proper airflow.



Important: Regardless of how many SATA/SCSI hard drives are installed, all drive carriers must remain in the drive bays to maintain proper airflow.

2. Installing/removing hot-swap SATA/SCSI drives

The SATA/SCSI drive carriers are all easily accessible at the front of the chassis. These hard drives are hot-pluggable, meaning they can be removed and installed without powering down the system. To remove a carrier, push the release button located beside the drive LEDs. Then swing the colored handle fully out and use it to pull the unit straight out (see Figure 6-4).

Note: Your operating system must have RAID support to enable the hot-plug capability of the SATA/SCSI drives.

Figure 6-4. Removing a Serial ATA Drive Carrier

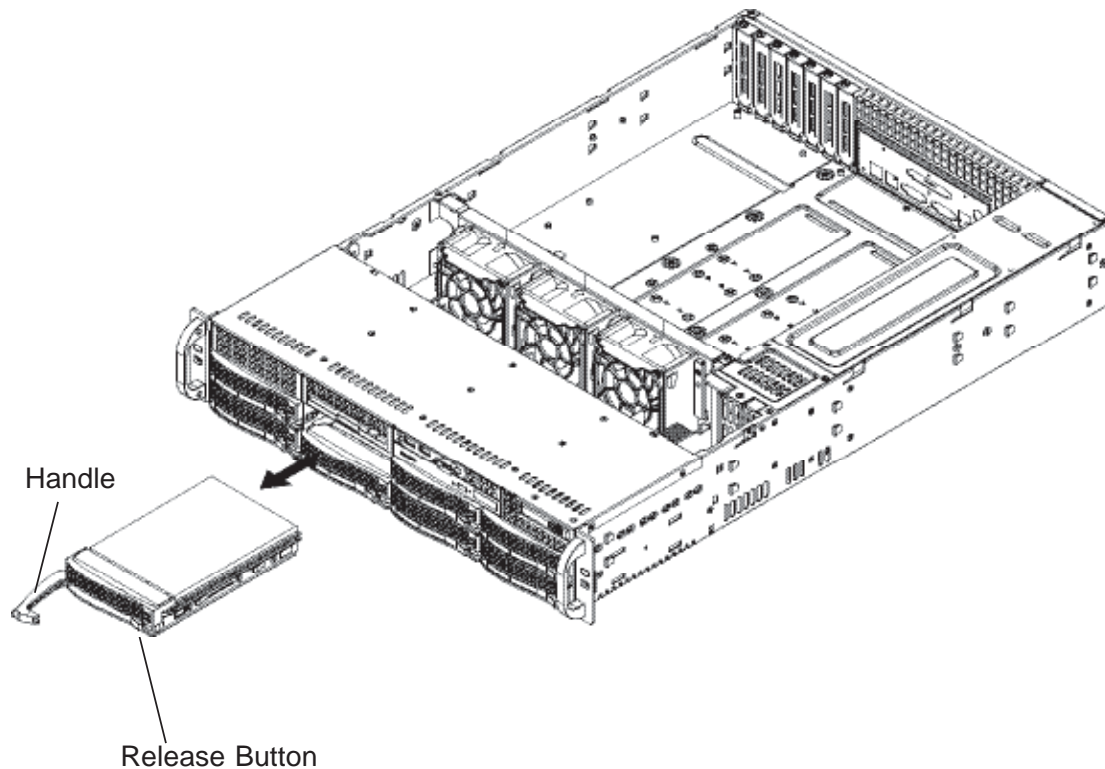

Important: All of the SATA/SCSI drive carriers must remain in the drive bays to maintain proper cooling airflow.

Hard Drive Backplane

The SATA/SCSI drives plug into a backplane that provides power, drive ID and bus termination. A RAID controller can be used with the backplane to provide data security. The operating system you use must have RAID support to enable the hot-swap capability of the Serial ATA drives. The backplane is already preconfigured, so there are no jumpers or switches present on it.

DVD-ROM and Floppy Drive Installation

The top cover of the chassis must be opened to gain full access to the DVD-ROM and floppy drive bays. The 2021M-T2R+/2021M-82R+ accommodates only slim type DVD-ROM drives. Side mounting brackets are typically needed to mount a slim DVD-ROM drive in the 2021M-T2R+/2021M-82R+ server.

First, release the retention screws that secure the server unit to the rack. Grasp the two handles on either side and pull the unit straight out until it locks (you will hear a "click"). Next, depress the two buttons on the top of the chassis to release the top cover and at the same time, push the cover away from you until it stops. You can then lift the top cover from the chassis to gain full access to the inside of the server. You must power down the system before installing or removing floppy or IDE components.

Drives mount on rails and should "click" into place to be correctly and fully installed in their bays.

- The floppy disk drive cable has seven twisted wires.
- A color mark on a cable typically designates the location of pin 1.
- A single floppy disk drive ribbon cable has 34 wires and two connectors to provide for two floppy disk drives. The connector with twisted wires always connects to drive A, and the connector that does not have twisted wires always connects to drive B.

6-5 Power Supply

The 2021M-T2R+/2021M-82R+ has a 700 watt redundant power supply consisting of two power modules. Each power supply module has an auto-switching capability, which enables it to automatically sense and operate at a 100V - 240V input voltage.

Power Supply Failure

If either of the two power supply modules fail, the other module will take the full load and allow the system to continue operation without interruption. The PWR Fail LED will illuminate and remain on until the failed unit has been replaced. Replacement units can be ordered directly from Supermicro (see contact information in the Preface). The power supply modules have a hot-swap capability, meaning you can replace the failed module without powering down the system.

Removing/Replacing the Power Supply

You do not need to shut down the system to replace a power supply module. The backup power supply module will keep the system up and running while you replace the failed hot-swap module. Replace with the same model (see part number in the Appendix), which can be ordered directly from Supermicro.

1. Removing the power supply

First unplug the power cord from the failed power supply module. Then depress the locking tab on the power supply module and use the handle to pull it straight out with the rounded handle.

2. Installing a new power supply

Replace the failed hot-swap module with another identical power supply. Simply push the new power supply module into the power bay until you hear a click. Secure the locking tab on the unit and finish by plugging the AC power cord back into the module.

Chapter 7

BIOS

7-1 Introduction

This chapter describes the AMIBIOS™ Setup utility for the H8DM8-2/H8DME-2. The AMI ROM BIOS is stored in a flash chip and can be easily upgraded using a floppy disk-based program.

Note: Due to periodic changes to the BIOS, some settings may have been added or deleted and might not yet be recorded in this manual. Please refer to the Manual Download area of our web site for any changes to BIOS that may not be reflected in this manual.

Starting the Setup Utility

To enter the BIOS Setup Utility, hit the <Delete> key while the system is booting-up. (In most cases, the <Delete> key is used to invoke the BIOS setup screen. There are a few cases when other keys are used, such as <F1>, <F2>, etc.) Each main BIOS menu option is described in this manual.

The Main BIOS screen has two main frames. The left frame displays all the options that can be configured. “Grayed-out” options cannot be configured. The right frame displays the key legend. Above the key legend is an area reserved for a text message. When an option is selected in the left frame, it is highlighted in white. Often a text message will accompany it. (Note that BIOS has default text messages built in. We retain the option to include, omit, or change any of these text messages.) Settings printed in **Bold** are the default values.

A " ►" indicates a submenu. Highlighting such an item and pressing the <Enter> key will open the list of settings within that submenu.

The BIOS setup utility uses a key-based navigation system called hot keys. Most of these hot keys (<F1>, <F10>, <Enter>, <ESC>, <Arrow> keys, etc.) can be used at any time during the setup navigation process.

7-2 Main Menu

When you first enter AMI BIOS Setup Utility, you will see the Main Menu screen. You can always return to the Main Menu by selecting the **Main** tab on the top of the screen with the arrow keys.

The Main Menu screen provides you with a system overview, which includes the version, built date and ID of the AMIBIOS, the type, speed and number of the processors in the system and the amount of memory installed in the system.

System Time/System Date

You can edit this field to change the system time and date. Highlight *System Time* or *System Date* using the <Arrow> keys. Enter new values through the keyboard. Press the <Tab> key or the <Arrow> keys to move between fields. The date must be entered in DAY/MM/DD/YYYY format. The time is entered in HH:MM:SS format. Please note that time is in a 24-hour format. For example, 5:30 A.M. appears as 05:30:00 and 5:30 P.M. as 17:30:00.

7-3 Advanced Settings Menu

► BIOS Features

Quick Boot

If Enabled, this option will skip certain tests during POST to reduce the time needed for the system to boot up. The options are **Enabled** and Disabled.

Quiet Boot

If Disabled, normal POST messages will be displayed on boot-up. If **Enabled**, this display the OEM logo instead of POST messages.

OS Installation

Change this setting if using a 64-bit Linux operating system. The available options are **Other** and Linux.

Interrupt 19 Capture

Select Enabled to allow ROMs to trap Interrupt 19. The options are Enabled and **Disabled**.

ACPI Mode

Use this setting to determine whether ACPI mode will be used. The options are **Yes** and No.

► Advanced ACPI Configuration

ACPI Version Features

Use this setting to determine which ACPI version to use. Options are **ACPI v1.0**, **ACPI v2.0** and **ACPI v3.0**.

ACPI APIC Support

Determines whether to include the ACPI APIC table pointer in the RSDT pointer list. The available options are **Enabled** and **Disabled**.

ACPI OEMB Table

Determines whether to include the ACPI APIC table pointer in the RSDT pointer list. The available options are **Enabled** and **Disabled**.

Headless Mode

Use this setting to **Enable** or **Disable** headless operation mode through ACPI.

Power Button Mode

Allows the user to change the function of the power button. Options are **On/Off** and **Suspend**.

Watch Dog Timer Select

This setting is used to **Enable** or **Disable** the Watch Dog Timer function. It must be used in conjunction with the Watch Dog jumper (see Chapter 2 for details). To enable, choose from 1, 2, 3, 4, 8, 15 or 30 min.

Restore on AC Power Loss

This setting allows you to choose how the system will react when power returns after an unexpected loss of power. The options are **Power Off**, **Power On** and **Last State**.

MPS Revision

This setting allows the user to select the MPS revision level. The options are 1.1 and 1.4.

► Floppy/IDE/SATA Configuration

Onboard Floppy Controller

Use this setting to **Enable** or Disable the onboard floppy controller.

Floppy A

Move the cursor to these fields via up and down <arrow> keys to select the floppy type. The options are Disabled, 360 KB 5 1/4", 1.2 MB 5 1/4", 720 KB 3 1/2", **1.44 MB 3 1/2"**, and 2.88 MB 3 1/2".

Onboard IDE Controller

There is a single floppy controller on the motherboard, which may be **Enabled** or Disabled with this setting.

Serial ATA Devices

This setting is used to determine if SATA drives will be used and how many. Options are Disabled, Device 0, Device 0/1 and **Device 0/1/2**.

► nVidia RAID Setup

nVidia RAID Function

This setting is used to Enable or **Disable** the nVidia ROM. If Enabled, the setting below will appear.

SATA0/1/2 Primary/Secondary Channel

This setting is used to Enable or **Disable** the SATA0 Primary, SATA0 Secondary, SATA1 Primary, SATA1 Secondary, SATA2 Primary and SATA2 Secondary channels (six settings total).

Primary IDE Master/Slave

Highlight one of the items above and press <Enter> to access the submenu for that item.

Type

Select the type of device connected to the system. The options are Not Installed, **Auto**, CDROM and ARMD.

LBA/Large Mode

LBA (Logical Block Addressing) is a method of addressing data on a disk drive. The options are Disabled and **Auto**.

Block (Multi-Sector Transfer)

Block mode boosts IDE drive performance by increasing the amount of data transferred. Only 512 bytes of data can be transferred per interrupt if block mode is not used. Block mode allows transfers of up to 64 KB per interrupt. Select "Disabled" to allow the data to be transferred from and to the device one sector at a time. Select "Auto" to allow the data transfer from and to the device occur multiple sectors at a time if the device supports it. The options are **Auto** and Disabled.

PIO Mode

PIO (Programmable I/O) mode programs timing cycles between the IDE drive and the programmable IDE controller. As the PIO mode increases, the cycle time decreases. The options are **Auto**, 0, 1, 2, 3, and 4. Select Auto to allow AMI BIOS to auto detect the PIO mode. Use this value if the IDE disk drive support cannot be determined. Select 0 to allow AMI BIOS to use PIO mode 0. It has a data transfer rate of 3.3 MBs. Select 1 to allow AMI BIOS to use PIO mode 1. It has a data transfer rate of 5.2 MBs. Select 2 to allow AMI BIOS to use PIO mode 2. It has a data transfer rate of 8.3 MBs. Select 3 to allow AMI BIOS to use PIO mode 3. It has a data transfer rate of 11.1 MBs. Select 4 to allow AMI BIOS to use PIO mode 4. It has a data transfer rate of 16.6 MBs. This setting generally works with all hard disk drives manufactured after 1999. For other disk drives, such as IDE CD-ROM drives, check the specifications of the drive.

DMA Mode

Selects the DMA Mode. Options are SWDMA0, SWDMA1, SWDMA2, MWDMA0, MDWDMA1, MWDMA2, UDMA0, UDMA1, UDMA2, UDMA3, UDMA4 and UDMA5. (SWDMA=Single Word DMA, MWDMA=Multi Word DMA, UDMA=UltraDMA.)

S.M.A.R.T.

Self-Monitoring Analysis and Reporting Technology (SMART) can help predict impending drive failures. Select "Auto" to allow BIOS to auto detect hard disk drive support. Select "Disabled" to prevent AMI BIOS from using the S.M.A.R.T. Select "Enabled" to allow AMI BIOS to use the S.M.A.R.T. to support hard drive disk. The options are Disabled, Enabled, and **Auto**.

32-Bit Data Transfer

Select "Enabled" to activate the function of 32-Bit data transfer. Select "Disabled" to deactivate the function. The options are Enabled and **Disabled**.

Serial ATA0/1/2 Primary/Secondary Channel

Highlight one of the items above and press <Enter> to access the submenu for that item. If a drive is present, information on that drive will be displayed here.

LBA/Large Mode

LBA (Logical Block Addressing) is a method of addressing data on a disk drive. The options are Disabled and **Auto**.

Block (Multi-Sector Transfer)

Block mode boosts IDE drive performance by increasing the amount of data transferred. Only 512 bytes of data can be transferred per interrupt if block mode is not used. Block mode allows transfers of up to 64 KB per interrupt. Select "Disabled" to allow the data to be transferred from and to the device one sector at a time. Select "Auto" to allow the data transfer from and to the device occur multiple sectors at a time if the device supports it. The options are **Auto** and Disabled.

PIO Mode

PIO (Programmable I/O) mode programs timing cycles between the IDE drive and the programmable IDE controller. As the PIO mode increases, the cycle time

decreases. The options are **Auto**, 0, 1, 2, 3, and 4. Select Auto to allow AMI BIOS to auto detect the PIO mode. Use this value if the IDE disk drive support cannot be determined. Select 0 to allow AMI BIOS to use PIO mode 0. It has a data transfer rate of 3.3 MBs. Select 1 to allow AMI BIOS to use PIO mode 1. It has a data transfer rate of 5.2 MBs. Select 2 to allow AMI BIOS to use PIO mode 2. It has a data transfer rate of 8.3 MBs. Select 3 to allow AMI BIOS to use PIO mode 3. It has a data transfer rate of 11.1 MBs. Select 4 to allow AMI BIOS to use PIO mode 4. It has a data transfer rate of 16.6 MBs. This setting generally works with all hard disk drives manufactured after 1999. For other disk drives, such as IDE CD-ROM drives, check the specifications of the drive.

DMA Mode

Selects the DMA Mode. Options are SWDMA0, SWDMA1, SWDMA2, MWDMA0, MDWDMA1, MWDMA2, UDMA0, UDMA1, UDMA2, UDMA3, UDMA4 and UDMA5. (SWDMA=Single Word DMA, MWDMA=Multi Word DMA, UDMA=UltraDMA.)

S.M.A.R.T.

Self-Monitoring Analysis and Reporting Technology (SMART) can help predict impending drive failures. Select "Auto" to allow BIOS to auto detect hard disk drive support. Select "Disabled" to prevent AMI BIOS from using the S.M.A.R.T. Select "Enabled" to allow AMI BIOS to use the S.M.A.R.T. to support hard drive disk. The options are Disabled, Enabled, and **Auto**.

32-Bit Data Transfer

Select "Enabled" to activate the function of 32-Bit data transfer. Select "Disabled" to deactivate the function. The options are Enabled and **Disabled**.

► **PCI/PnP Configuration**

Load Onboard LAN Option ROM

Use this setting to Enable or **Disable** the onboard option ROM.

Clear NVRAM

Select Yes to clear NVRAM during boot-up. The options are Yes and **No**.

Plug & Play OS

Select Yes to allow the OS to configure Plug & Play devices. (This is not required for system boot if your system has an OS that supports Plug & Play.) Select **No** to allow AMIBIOS to configure all devices in the system.

PCI Latency Timer

This option sets the latency of all PCI devices on the PCI bus. Select a value to set the PCI latency in PCI clock cycles. Options are 32, **64**, 96, 128, 160, 192, 224 and 248.

Allocate IRQ to PCI VGA

Set this value to allow or restrict the system from giving the VGA adapter card an interrupt address. The options are **Yes** and No.

Palette Snooping

Select "Enabled" to inform the PCI devices that an ISA graphics device is installed in the system in order for the graphics card to function properly. The options are Enabled and **Disabled**.

PCI IDE BusMaster

Set this value to allow or prevent the use of PCI IDE busmastering. Select "Enabled" to allow AMI BIOS to use PCI busmaster for reading and writing to IDE drives. The options are **Disabled** and Enabled.

Offboard PCI/ISA IDE Card

This option allows the user to assign a PCI slot number to an Off-board PCI/ISA IDE card in order for it to function properly. The options are **Auto**, PCI Slot1, PCI Slot2, PCI Slot3, PCI Slot4, PCI Slot5, and PCI Slot6.

- ▶ **Advanced Chipset Control**
- ▶ **NorthBridge Configuration**
- ▶ **Memory Configuration**

Memclock Mode

This setting determines how the memory clock is set. **Auto** has the memory clock by code and **Limit** allows the user to set a standard value.

MCT Timing Mode

Sets the timing mode for memory. Options are **Auto** and **Manual**.

Bank Interleaving

Select **Auto** to automatically enable interleaving-memory scheme when this function is supported by the processor. The options are **Auto** and **Disabled**.

Enable Clock to All Dimms

Use this setting to enable unused clocks to all DIMMSs, even if some DIMM slots are unpopulated. Options are **Enabled** and **Disabled**.

Mem Clk Tristate C3/ALTVID

Use this setting to **Enable** or **Disable** memory clock tristate during C3 and ALT VID.

CS Sparing

This setting will reserve a spare memory rank in each node when enabled. Options are **Enable** and **Disable**.

DQS Signal Training Control

Turning off signal training will require custom memory timings programming. This setting will automatically be disabled when CS Sparing is enabled. The options are **Enable** and **Disable**.

Memory Hole Remapping

When "Enabled", this feature enables hardware memory remapping around the memory hole. Options are **Enabled** and **Disabled**.

► ECC Configuration

DRAM ECC Enable

DRAM ECC allows hardware to report and correct memory errors automatically. Options are **Enabled** and Disabled.

4-Bit ECC Mode

Allows the user to enable 4-bit ECC mode (also known as ECC Chipkill). Options are Enabled and **Disabled**.

DRAM Scrub Redirect

Allows system to correct DRAM ECC errors immediately, even with background scrubbing on. Options are Enabled and **Disabled**.

DRAM BG Scrub

Corrects memory errors so later reads are correct. Options are **Disabled** and various times in nanoseconds and microseconds.

L2 Cache BG Scrub

Allows L2 cache RAM to be corrected when idle. Options are **Disabled** and various times in nanoseconds and microseconds.

Data Cache BG Scrub

Allows L1 cache RAM to be corrected when idle. Options are **Disabled** and various times in nanoseconds and microseconds.

Power Down Control

Allows DIMMs to enter power down mode by deasserting the clock enable signal when DIMMs are not in use. Options are **Auto** and Disabled.

Alternate VID

Specify the alternate VID while in low power states. Options are **Auto** and various voltages from .800V to 1.050V in increments of .025V.

Memory Timing Parameters

Allows the user to select which CPU Node's timing parameters (memory clock, etc.) to display. Options are **CPU Node 0** and CPU Node1.

► SouthBridge Configuration

USB 1.1 Controller

Enable or disable the USB 1.1 controller.

USB 2.0 Controller

Enable or disable the USB 2.0 controller.

MAC0 LAN0

Settings are **Auto** and Disabled for MAC0 LAN0.

MAC0 LAN0 Bridge

Settings are **Enabled** and Disabled for MAC0 LAN0 bridge.

MAC1 LAN1

Settings are **Auto** and Disabled for MAC1 LAN1.

MAC1 LAN1 Bridge

Settings are **Enabled** and Disabled for MAC1 LAN1 bridge.

Legacy USB Support

Select "Enabled" to enable the support for USB Legacy. Disable Legacy support if there are no USB devices installed in the system. "Auto" disabled Legacy support if no USB devices are connected. The options are Disabled, **Enabled** and Auto.

USB Mass Storage Reset Delay

Use this setting to define the number of seconds the POST routine waits for the mass storage device after the start unit command. Options are 10, **20**, 30 and 40 seconds.

Emulation Type

Selects emulation type for USB device. If Auto, a USB device less than 530MB will be emulated as a floppy and the remaining as hard drives. The Forced FDD option can be used to force a formatted HDD drive to boot as a FDD (Ex. Zip Drive). Options are **Auto**, Floppy, Forced FDD, Hard Disk and CDROM.

► Processor & Clock Options

This submenu lists CPU information and the following settings:

MTRR Mapping

This determines the method used for programming CPU MTRRs when 4 GB or more memory is present. The options are **Continuous**, which makes the PCI hole non-cacheable, and **Discrete**, which places the PCI hole below the 4 GB boundary.

Thermal Throttling

Used to **Enable** or **Disable** thermal to generate a power management event.

Power Now

This setting is used to **Enable** or **Disable** the AMD Power Now feature.

► I/O Device Configuration

Serial Port1 Address

This option specifies the base I/O port address and Interrupt Request address of serial port 1. Select "Disabled" to prevent the serial port from accessing any system resources. When this option is set to *Disabled*, the serial port physically becomes unavailable. Select "3F8/IRQ4" to allow the serial port to use 3F8 as its I/O port address and IRQ 4 for the interrupt address. The options are Disabled, **3F8/IRQ4**, 3E8/IRQ4 and 2E8/IRQ3.

Serial Port2 Address

This option specifies the base I/O port address and Interrupt Request address of serial port 2. Select "Disabled" to prevent the serial port from accessing any system resources. When this option is set to "Disabled", the serial port physically becomes unavailable. Select "2F8/IRQ3" to allow the serial port to use 2F8 as its I/O port address and IRQ 3 for the interrupt address. The options are Disabled, **2F8/IRQ3**, 3E8/IRQ4 and 2E8/IRQ3.

Serial Port 2 Mode

Tells BIOS which mode to select for serial port 2. The options are **Normal**, IrDA and ASKIR.

► DMI Event Logging

View Event Log

Highlight this item and press <Enter> to view the contents of the event log.

Mark All Events as Read

Highlight this item and press <Enter> to mark all events as read.

Clear Event Log

Select Yes and press <Enter> to clear all event logs. The options are Yes and No to verify.

► Console Redirection

Remote Access

Allows you to Enable or **Disable** remote access. If enabled, the settings below will appear.

Serial Port Number

Selects the serial port to use for console redirection. Options are **COM1** and COM2.

Serial Port Mode

Selects the serial port settings to use. Options are **(115200 8, n, 1)**, (57600 8, n, 1), (38400 8, n, 1), (19200 8, n, 1) and (09600 8, n, 1).

Flow Control

Selects the flow control to be used for console redirection. Options are **None**, Hardware and Software.

Redirection After BIOS POST

Options are Disable (no redirection after BIOS POST), Boot Loader (redirection during POST and during boot loader) and **Always** (redirection always active). Note that some OS's may not work with this set to Always.

Terminal Type

Selects the type of the target terminal. Options are **ANSI**, VT100 and VT-UTF8.

VT-UTF8 Combo Key Support

Allows you to **Enable** or Disable VT-UTF8 combination key support for ANSI/VT100 terminals.

Sredir Memory Display Delay

Use this setting to set the delay in seconds to display memory information. Options are **No Delay**, 1 sec, 2 secs and 4 secs.

▶ **Hardware Health Monitor**

CPU Overheat Alarm

Use the "+" and "-" keys to set the CPU temperature threshold to between 65° and 90° C. When this threshold is exceeded, the overheat LED on the chassis will light up and an alarm will sound. The LED and alarm will turn off once the CPU temperature has dropped to 5 degrees below the threshold set. The default setting is **72° C**.

▶ **System Fan Monitor**

Fan Speed Control

This feature allows the user to determine how the system will control the speed of the onboard fans. Select "Workstation" if your system is used as a Workstation. Select "Server" if your system is used as a Server. Select "Disable" to disable the fan speed control function to allow the onboard fans to continuously run at full speed (12V). The options are **1) Disable (Full Speed)** 2) 3-pin (Server) 3) 3-pin (Workstation).

FAN1 Speed through FAN8 Reading

The speeds of the onboard fans (in rpm) are displayed here.

Other items in the submenu are systems monitor displays for the following information:

CPU1 Temperature, CPU2 Temperature (for dual systems), System Temperature, VCoreA, VCoreB (for 2U systems), HT Voltage, CPU1 Mem VTT, CPU2 Mem VTT, CPU1 Mem, CPU2 Mem, VDD, 1.5V, MCP55 VCore, 3.3V, 12V, -12V, 5V VSB and VBAT.

▶ IPMI Configuration

▶ View BMC System Event Log

Pressing the Enter key will open the following settings. Use the "+" and "-" keys to navigate through the system event log.

Clear BMC System Event Log

Selecting this and pressing the Enter key will clear the BMC system event log.

▶ Set LAN Configuration

Use the "+" and "-" keys to choose the desired channel number.

▶ IP Address

Use the "+" and "-" keys to select the parameter. The IP address and current IP address in the BMC are shown.

▶ MAC Address

Use the "+" and "-" keys to select the parameter. The MAC address and current MAC address in the BMC are shown.

▶ Subnet Address

Use the "+" and "-" keys to select the parameter. The subnet address and current subnet address in the BMC are shown.

▶ Set PEF Configuration

PEF Support

Use this setting to **Enable** or Disable PEF support.

PEF Action Global Control

Options are **Alert**, Power Down, Reset System, Power Cycle, OEM Action and Diagnostic Int..

Alert Startup Delay

Use this setting to Enable or **Disable** the alert startup delay.

Startup Delay

Use this setting to Enable or **Disable** the startup delay.

Event Message for PEF Action

Use this setting to Enable or **Disable** event messages for a PEF action.

BMC Watch Dog Timer Action

This setting is used to set the Watch Dog function. The options are **Disabled**, Reset System, Power Down and Power Cycle.

7-4 Boot Menu

This feature allows the user to configure the following items:

▶ Boot Device Priority

This feature allows the user to prioritize the boot sequence from the available devices.

▶ Hard Disk Drives

This feature allows the user to specify the boot sequence from available hard disk drives.

▶ Removable Drives

This feature allows the user to specify the Boot sequence from available removable drives.

▶ CD/DVD Drives

This feature allows the user to specify the Boot sequence from available CD/DVD drives.

7-5 Security Menu

AMI BIOS provides a Supervisor and a User password. If you use both passwords, the Supervisor password must be set first.

Change Supervisor Password

Select this option and press <Enter> to access the sub menu, and then type in the password.

Change User Password

Select this option and press <Enter> to access the sub menu, and then type in the password.

Boot Sector Virus Protection

This option is near the bottom of the Security Setup screen. Select "Disabled" to deactivate the Boot Sector Virus Protection. Select "Enabled" to enable boot sector protection. When "Enabled", AMI BIOS displays a warning when any program (or virus) issues a Disk Format command or attempts to write to the boot sector of the hard disk drive. The options are Enabled and **Disabled**.

7-6 Exit Menu

Select the Exit tab from AMI BIOS Setup Utility screen to enter the Exit BIOS Setup screen.

Save Changes and Exit

When you have completed the system configuration changes, select this option to leave BIOS Setup and reboot the computer, so the new system configuration parameters can take effect. Select Save Changes and Exit from the Exit menu and press <Enter>.

Discard Changes and Exit

Select this option to quit BIOS Setup without making any permanent changes to the system configuration and reboot the computer. Select Discard Changes and Exit from the Exit menu and press <Enter>.

Discard Changes

Select this option and press <Enter> to discard all the changes and return to AMI BIOS Utility Program.

Load Optimal Defaults

To set this feature, select Load Optimal Defaults from the Exit menu and press <Enter>. Then Select "OK" to allow BIOS to automatically load the Optimal Defaults as the BIOS Settings. The Optimal settings are designed for maximum system performance, but may not work best for all computer applications.

Load Fail-Safe Defaults

To set this feature, select Load Fail-Safe Defaults from the Exit menu and press <Enter>. The Fail-Safe settings are designed for maximum system stability, but not maximum performance.

Appendix A

BIOS Error Beep Codes

During the POST (Power-On Self-Test) routines, which are performed each time the system is powered on, errors may occur.

Non-fatal errors are those which, in most cases, allow the system to continue the boot-up process. The error messages normally appear on the screen.

Fatal errors are those which will not allow the system to continue the boot-up procedure. If a fatal error occurs, you should consult with your system manufacturer for possible repairs.

These fatal errors are usually communicated through a series of audible beeps. The numbers on the fatal error list, on the following page, correspond to the number of beeps for the corresponding error. All errors listed, with the exception of Beep Code 8, are fatal errors.

POST codes may be read on the debug LEDs located beside the LAN port on the serverboard backplane. See the description of the Debug LEDs (LED1 and LED2) in Chapter 5.

A-1 AMIBIOS Error Beep Codes

Beep Code	Error Message	Description
1 beep	Refresh	Circuits have been reset. (Ready to power up.)
5 short, 1 long	Memory error	No memory detected in system
8 beeps	Display memory read/write error	Video adapter missing or with faulty memory

Notes

Appendix B

BIOS POST Checkpoint Codes

When AMIBIOS performs the Power On Self Test, it writes checkpoint codes to I/O port 0080h. If the computer cannot complete the boot process, diagnostic equipment can be attached to the computer to read I/O port 0080h.

B-1 Uncompressed Initialization Codes

The uncompressed initialization checkpoint codes are listed in order of execution:

Checkpoint	Code Description
D0h	The NMI is disabled. Power on delay is starting. Next, the initialization code checksum will be verified.
D1h	Initializing the DMA controller, performing the keyboard controller BAT test, starting memory refresh and entering 4 GB flat mode next.
D3h	Starting memory sizing next.
D4h	Returning to real mode. Executing any OEM patches and setting the Stack next.
D5h	Passing control to the uncompressed code in shadow RAM at E000:0000h. The initialization code is copied to segment 0 and control will be transferred to segment 0.

B-2 Bootblock Recovery Codes

The bootblock recovery checkpoint codes are listed in order of execution:

Checkpoint	Code Description
E0h	The onboard floppy controller if available is initialized. Next, beginning the base 512 KB memory test.
E1h	Initializing the interrupt vector table next.
E2h	Initializing the DMA and Interrupt controllers next.
E6h	Enabling the floppy drive controller and Timer IRQs. Enabling internal cache memory.
Edh	Initializing the floppy drive.
Eeh	Looking for a floppy diskette in drive A:.. Reading the first sector of the diskette.
Efh	A read error occurred while reading the floppy drive in drive A:..
F0h	Next, searching for the AMIBOOT.ROM file in the root directory.
F1h	The AMIBOOT.ROM file is not in the root directory.
F2h	Next, reading and analyzing the floppy diskette FAT to find the clusters occupied by the AMIBOOT.ROM file.
F3h	Next, reading the AMIBOOT.ROM file, cluster by cluster.
F4h	The AMIBOOT.ROM file is not the correct size.
F5h	Next, disabling internal cache memory.
FBh	Next, detecting the type of flash ROM.
FCh	Next, erasing the flash ROM.
FDh	Next, programming the flash ROM.
FFh	Flash ROM programming was successful. Next, restarting the system BIOS.

B-3 Uncompressed Initialization Codes

The following runtime checkpoint codes are listed in order of execution.

These codes are uncompressed in F0000h shadow RAM.

Checkpoint	Code Description
03h	The NMI is disabled. Next, checking for a soft reset or a power on condition.
05h	The BIOS stack has been built. Next, disabling cache memory.
06h	Uncompressing the POST code next.
07h	Next, initializing the CPU and the CPU data area.
08h	The CMOS checksum calculation is done next.
0Ah	The CMOS checksum calculation is done. Initializing the CMOS status register for date and time next.
0Bh	The CMOS status register is initialized. Next, performing any required initialization before the keyboard BAT command is issued.
0Ch	The keyboard controller input buffer is free. Next, issuing the BAT command to the keyboard controller.
0Eh	The keyboard controller BAT command result has been verified. Next, performing any necessary initialization after the keyboard controller BAT command test.
0Fh	The initialization after the keyboard controller BAT command test is done. The keyboard command byte is written next.
10h	The keyboard controller command byte is written. Next, issuing the Pin 23 and 24 blocking and unblocking command.
11h	Next, checking if <End or <Ins> keys were pressed during power on. Initializing CMOS RAM if the Initialize CMOS RAM in every boot AMIBIOS POST option was set in AMIBCP or the <End> key was pressed.
12h	Next, disabling DMA controllers 1 and 2 and interrupt controllers 1 and 2.
13h	The video display has been disabled. Port B has been initialized. Next, initializing the chipset.
14h	The 8254 timer test will begin next.
19h	Next, programming the flash ROM.
1Ah	The memory refresh line is toggling. Checking the 15 second on/off time next.
2Bh	Passing control to the video ROM to perform any required configuration before the video ROM test.
2Ch	All necessary processing before passing control to the video ROM is done. Looking for the video ROM next and passing control to it.
2Dh	The video ROM has returned control to BIOS POST. Performing any required processing after the video ROM had control
23h	Reading the 8042 input port and disabling the MEGAKEY Green PC feature next. Making the BIOS code segment writable and performing any necessary configuration before initializing the interrupt vectors.
24h	The configuration required before interrupt vector initialization has completed. Interrupt vector initialization is about to begin.

Checkpoint	Code Description
25h	Interrupt vector initialization is done. Clearing the password if the POST DIAG switch is on.
27h	Any initialization before setting video mode will be done next.
28h	Initialization before setting the video mode is complete. Configuring the monochrome mode and color mode settings next.
2Ah	Bus initialization system, static, output devices will be done next, if present. See the last page for additional information.
2Eh	Completed post-video ROM test processing. If the EGA/VGA controller is not found, performing the display memory read/write test next.
2Fh	The EGA/VGA controller was not found. The display memory read/write test is about to begin.
30h	The display memory read/write test passed. Look for retrace checking next.
31h	The display memory read/write test or retrace checking failed. Performing the alternate display memory read/write test next.
32h	The alternate display memory read/write test passed. Looking for alternate display retrace checking next.
34h	Video display checking is over. Setting the display mode next.
37h	The display mode is set. Displaying the power on message next.
38h	Initializing the bus input, IPL, general devices next, if present. See the last page of this chapter for additional information.
39h	Displaying bus initialization error messages. See the last page of this chapter for additional information.
3Ah	The new cursor position has been read and saved. Displaying the Hit message next.
3Bh	The Hit message is displayed. The protected mode memory test is about to start.
40h	Preparing the descriptor tables next.
42h	The descriptor tables are prepared. Entering protected mode for the memory test next.
43h	Entered protected mode. Enabling interrupts for diagnostics mode next.
44h	Interrupts enabled if the diagnostics switch is on. Initializing data to check memory wraparound at 0:0 next.
45h	Data initialized. Checking for memory wraparound at 0:0 and finding the total system memory size next.
46h	The memory wraparound test is done. Memory size calculation has been done. Writing patterns to test memory next.
47h	The memory pattern has been written to extended memory. Writing patterns to the base 640 KB memory next.
48h	Patterns written in base memory. Determining the amount of memory below 1 MB next.
49h	The amount of memory below 1 MB has been found and verified.
4Bh	The amount of memory above 1 MB has been found and verified. Checking for a soft reset and clearing the memory below 1 MB for the soft reset next. If this is a power on situation, going to checkpoint 4Eh next.

Checkpoint	Code Description
4Ch	The memory below 1 MB has been cleared via a soft reset. Clearing the memory above 1 MB next.
4Dh	The memory above 1 MB has been cleared via a soft reset. Saving the memory size next. Going to checkpoint 52h next.
4Eh	The memory test started, but not as the result of a soft reset. Displaying the first 64 KB memory size next.
4Fh	The memory size display has started. The display is updated during the memory test. Performing the sequential and random memory test next.
50h	The memory below 1 MB has been tested and initialized. Adjusting the displayed memory size for relocation and shadowing next.
51h	The memory size display was adjusted for relocation and shadowing.
52h	The memory above 1 MB has been tested and initialized. Saving the memory size information next.
53h	The memory size information and the CPU registers are saved. Entering real mode next.
54h	Shutdown was successful. The CPU is in real mode. Disabling the Gate A20 line, parity, and the NMI next.
57h	The A20 address line, parity, and the NMI are disabled. Adjusting the memory size depending on relocation and shadowing next.
58h	The memory size was adjusted for relocation and shadowing. Clearing the Hit message next.
59h	The Hit message is cleared. The <WAIT...> message is displayed. Starting the DMA and interrupt controller test next.
60h	The DMA page register test passed. Performing the DMA Controller 1 base register test next.
62h	The DMA controller 1 base register test passed. Performing the DMA controller 2 base register test next.
65h	The DMA controller 2 base register test passed. Programming DMA controllers 1 and 2 next.
66h	Completed programming DMA controllers 1 and 2. Initializing the 8259 interrupt controller next.
67h	Completed 8259 interrupt controller initialization.
7Fh	Extended NMI source enabling is in progress.
80h	The keyboard test has started. Clearing the output buffer and checking for stuck keys. Issuing the keyboard reset command next.
81h	A keyboard reset error or stuck key was found. Issuing the keyboard controller interface test command next.
82h	The keyboard controller interface test completed. Writing the command byte and initializing the circular buffer next.
83h	The command byte was written and global data initialization has completed. Checking for a locked key next.
84h	Locked key checking is over. Checking for a memory size mismatch with CMOS RAM data next.
85h	The memory size check is done. Displaying a soft error and checking for a password or bypassing WINBIOS Setup next.

Checkpoint	Code Description
86h	The password was checked. Performing any required programming before WINBIOS Setup next.
87h	The programming before WINBIOS Setup has completed. Uncompressing the WINBIOS Setup code and executing the AMIBIOS Setup or WINBIOS Setup utility next.
88h	Returned from WINBIOS Setup and cleared the screen. Performing any necessary programming after WINBIOS Setup next.
89h	The programming after WINBIOS Setup has completed. Displaying the power on screen message next.
8Ch	Programming the WINBIOS Setup options next.
8Dh	The WINBIOS Setup options are programmed. Resetting the hard disk controller next.
8Fh	The hard disk controller has been reset. Configuring the floppy drive controller next.
91h	The floppy drive controller has been configured. Configuring the hard disk drive controller next.
95h	Initializing the bus option ROMs from C800 next. See the last page of this chapter for additional information.
96h	Initializing before passing control to the adaptor ROM at C800.
97h	Initialization before the C800 adaptor ROM gains control has completed. The adaptor ROM check is next.
98h	The adaptor ROM had control and has now returned control to BIOS POST. Performing any required processing after the option ROM returned control.
99h	Any initialization required after the option ROM test has completed. Configuring the timer data area and printer base address next.
9Ah	Set the timer and printer base addresses. Setting the RS-232 base address next.
9Bh	Returned after setting the RS-232 base address. Performing any required initialization before the Coprocessor test next.
9Ch	Required initialization before the Coprocessor test is over. Initializing the Coprocessor next.
9Dh	Coprocessor initialized. Performing any required initialization after the Coprocessor test next.
9Eh	Initialization after the Coprocessor test is complete. Checking the extended keyboard, keyboard ID, and Num Lock key next. Issuing the keyboard ID command next.
A2h	Displaying any soft errors next.
A3h	The soft error display has completed. Setting the keyboard typematic rate next.
A4h	The keyboard typematic rate is set. Programming the memory wait states next.
A5h	Memory wait state programming is over. Clearing the screen and enabling parity and the NMI next.
A7h	NMI and parity enabled. Performing any initialization required before passing control to the adaptor ROM at E000 next.
A8h	Initialization before passing control to the adaptor ROM at E000h completed. Passing control to the adaptor ROM at E000h next.

Checkpoint	Code Description
A9h	Returned from adaptor ROM at E000h control. Performing any initialization required after the E000 option ROM had control next.
Aah	Initialization after E000 option ROM control has completed. Displaying the system configuration next.
Abh	Uncompressing the DMI data and executing DMI POST initialization next.
B0h	The system configuration is displayed.
B1h	Copying any code to specific areas.
00h	Code copying to specific areas is done. Passing control to INT 19h boot loader next.

Notes

Appendix C

System Specifications

Processors

Single or dual AMD Opteron 2000 series (Socket F) type processors

Note: Please refer to our web site for a complete listing of supported processors.

Chipset

nVidia MCP55 Pro and NEC 720400 chipset

BIOS

8 Mb AMI® Flash ROM

Memory Capacity

Sixteen 240-pin DIMM sockets supporting up to 32/32/64 GB of registered ECC DDR2-667/533/400 SDRAM.

Note: Memory may be installed to provide interleaved or non-interleaved configurations. See the memory section in Chapter 5 for details.

Serial ATA Controller (2021M-T2R+ only)

On-chip controller for six-port Serial ATA subsystem (RAID 0, 1, 0+1, 5 and JBOD supported)

SCSI Controller (2021M-82R+ only)

On-chip controller for eight-port SCSI subsystem (RAID 0, 1, 10 and JBOD supported)

SCSI/SATA Drive Bays

Eight (8) hot-swap drive bays to house eight (8) standard SCSI or six (6) standard SATA drives

Peripheral Drive Bays

One (1) slim floppy drive

One (1) slim DVD-ROM drive

Expansion Slots

Two PCI-Express x8 slots, two 64-bit 133 MHz PCI-X slots and two 64-bit 100 MHz PCI-X slots (supports ZCR) all with low-profile cards

Serverboard

2021M-T2R+: H8DME-2 (Extended ATX form factor)

Dimensions: 12 x 13.05 in (305 x 331 mm)

2021M-82R+: H8DM8-2 (Extended ATX form factor)

Dimensions: 12 x 13.05 in (305 x 331 mm)

Chassis

2021M-T2R+: SC825TQ-R700LP, 2U rackmount

2021M-82R+: SC825S2-R700LP, 2U rackmount

Dimensions (both): (WxHxD) 16.8 x 3.5 x 25.5 in. (427 x 89 x 648 mm)

Weight

Gross (Bare Bone): 57 lbs. (25.9 kg.)

System Cooling

Three (3) 8-cm system cooling fans

System Input Requirements

AC Input Voltage: 100-240V AC auto-range

Rated Input Current: 10A - 4A

Rated Input Frequency: 50 to 60 Hz

Power Supply

Rated Output Power: 700W (Model# SP801-1R, Part# PWS-702A-1R)

Rated Output Voltages: +12V (58A), +5Vsb (4A)

BTU Rating

3431 BTUs/hr (for rated output power of 700W)

Operating Environment

Operating Temperature: 10° to 35° C (50° to 95° F)

Non-operating Temperature: -40° to 70° C (-40° to 158° F)

Operating Relative Humidity: 8% to 90% (non-condensing)

Non-operating Relative Humidity: 5 to 95% (non-condensing)

Regulatory Compliance

Electromagnetic Emissions:

FCC Class A, EN 55022 Class A, EN 61000-3-2/-3-3, CISPR 22 Class A

Electromagnetic Immunity:

EN 55024/CISPR 24, (EN 61000-4-2, EN 61000-4-3, EN 61000-4-4,
EN 61000-4-5, EN 61000-4-6, EN 61000-4-8, EN 61000-4-11)

Safety:

EN 60950/IEC 60950-Compliant, UL Listed (USA), CUL Listed (Canada), TUV
Certified (Germany), CE Marking (Europe)

(continued from front)

The products sold by Supermicro are not intended for and will not be used in life support systems, medical equipment, nuclear facilities or systems, aircraft, aircraft devices, aircraft/emergency communication devices or other critical systems whose failure to perform be reasonably expected to result in significant injury or loss of life or catastrophic property damage. Accordingly, Supermicro disclaims any and all liability, and should buyer use or sell such products for use in such ultra-hazardous applications, it does so entirely at its own risk. Furthermore, buyer agrees to fully indemnify, defend and hold Supermicro harmless for and against any and all claims, demands, actions, litigation, and proceedings of any kind arising out of or related to such ultra-hazardous use or sale.