



SuperServer[®]
SYS-621BT-HNTR
SYS-621BT-HNC8R



USER'S MANUAL

Revision 1.1

The information in this User's Manual has been carefully reviewed and is believed to be accurate. The vendor assumes no responsibility for any inaccuracies that may be contained in this document, and makes no commitment to update or to keep current the information in this manual, or to notify any person or organization of the updates. Please Note: For the most up-to-date version of this manual, please see our website at www.supermicro.com.

Super Micro Computer, Inc. ("Supermicro") reserves the right to make changes to the product described in this manual at any time and without notice. This product, including software and documentation, is the property of Supermicro and/or its licensors, and is supplied only under a license. Any use or reproduction of this product is not allowed, except as expressly permitted by the terms of said license.

IN NO EVENT WILL Super Micro Computer, Inc. BE LIABLE FOR DIRECT, INDIRECT, SPECIAL, INCIDENTAL, SPECULATIVE OR CONSEQUENTIAL DAMAGES ARISING FROM THE USE OR INABILITY TO USE THIS PRODUCT OR DOCUMENTATION, EVEN IF ADVISED OF THE POSSIBILITY OF SUCH DAMAGES. IN PARTICULAR, SUPER MICRO COMPUTER, INC. SHALL NOT HAVE LIABILITY FOR ANY HARDWARE, SOFTWARE, OR DATA STORED OR USED WITH THE PRODUCT, INCLUDING THE COSTS OF REPAIRING, REPLACING, INTEGRATING, INSTALLING OR RECOVERING SUCH HARDWARE, SOFTWARE, OR DATA.

Any disputes arising between manufacturer and customer shall be governed by the laws of Santa Clara County in the State of California, USA. The State of California, County of Santa Clara shall be the exclusive venue for the resolution of any such disputes. Supermicro's total liability for all claims will not exceed the price paid for the hardware product.

FCC Statement: This equipment has been tested and found to comply with the limits for a Class A or Class B digital device pursuant to Part 15 of the FCC Rules. These limits are designed to provide reasonable protection against harmful interference when the equipment is operated in industrial environment for Class A device or in residential environment for Class B device. This equipment generates, uses, and can radiate radio frequency energy and, if not installed and used in accordance with the manufacturer's instruction manual, may cause harmful interference with radio communications. Operation of this equipment in a residential area is likely to cause harmful interference, in which case you will be required to correct the interference at your own expense.

California Best Management Practices Regulations for Perchlorate Materials: This Perchlorate warning applies only to products containing CR (Manganese Dioxide) Lithium coin cells. "Perchlorate Material-special handling may apply. See www.dtsc.ca.gov/hazardouswaste/perchlorate".



WARNING: This product can expose you to chemicals including lead, known to the State of California to cause cancer and birth defects or other reproductive harm. For more information, go to www.P65Warnings.ca.gov.

The products sold by Supermicro are not intended for and will not be used in life support systems, medical equipment, nuclear facilities or systems, aircraft, aircraft devices, aircraft/emergency communication devices or other critical systems whose failure to perform be reasonably expected to result in significant injury or loss of life or catastrophic property damage. Accordingly, Supermicro disclaims any and all liability, and should buyer use or sell such products for use in such ultra-hazardous applications, it does so entirely at its own risk. Furthermore, buyer agrees to fully indemnify, defend and hold Supermicro harmless for and against any and all claims, demands, actions, litigation, and proceedings of any kind arising out of or related to such ultra-hazardous use or sale.

Manual Revision 1.1

Release Date: May 29, 2025

Unless you request and receive written permission from Super Micro Computer, Inc., you may not copy any part of this document. Information in this document is subject to change without notice. Other products and companies referred to herein are trademarks or registered trademarks of their respective companies or mark holders.

Copyright © 2025 by Super Micro Computer, Inc.
All rights reserved.

Printed in the United States of America

Preface

About this Manual

This manual is written for professional system integrators and PC technicians. It provides information for the installation and use of the server. Installation and maintenance should be performed by experienced technicians only.

Please refer to the SYS-621BT-H Series server specifications page on our website for updates on supported memory, processors and operating systems (<http://www.supermicro.com>).

Notes

For your system to work properly, please follow the links below to download all necessary drivers/utilities and the user's manual for your server.

- Supermicro product manuals: <http://www.supermicro.com/support/manuals/>
- Product drivers and utilities: <https://www.supermicro.com/wdl>
- Product safety info: http://www.supermicro.com/about/policies/safety_information.cfm

If you have any questions, please contact our support team at:
support@supermicro.com

This manual may be periodically updated without notice. Please check the Supermicro website for possible updates to the manual revision level.

Secure Data Deletion

A secure data deletion tool designed to fully erase all data from storage devices can be found on our website: https://www.supermicro.com/about/policies/disclaimer.cfm?url=/wdl/utility/Lot9_Secure_Data_Deletion_Utility/

Warnings

Special attention should be given to the following symbols used in this manual.



Warning! Indicates important information given to prevent equipment/property damage or personal injury.



Warning! Indicates high voltage may be encountered when performing a procedure.

Contents

Contacting Supermicro.....	9
Chapter 1 Introduction	
1.1 Overview.....	10
1.2 System Features	11
Front View	11
Front View: SYS-621BT-HNTR	12
Front View: SYS-621BT-HNC8R.....	12
Control Panel.....	13
Rear View.....	14
1.3 System Architecture	15
System Block Diagram.....	16
1.4 Motherboard Layout	17
Quick Reference Table.....	18
Chapter 2 Server Installation	
2.1 Overview.....	20
2.2 Unpacking the System	20
2.3 Preparing for Setup.....	20
Choosing a Setup Location.....	20
Rack Precautions	21
Server Precautions.....	21
Rack Mounting Considerations	21
Ambient Operating Temperature.....	21
Airflow	22
Mechanical Loading.....	22
Circuit Overloading	22
Reliable Ground.....	22
2.4 Rack Mounting Instructions.....	23
Overview of the Rack Rails.....	23
Adjusting the Rail Length	23
Installing the Rails on a Rack	24
Chassis Installation	25

Chapter 3 Maintenance and Component Installation

3.1 Removing Power	26
3.2 Accessing the System.....	27
Removing a Computing Node Drawer	27
Removing the Chassis Cover	28
3.3 Static-Sensitive Devices.....	29
Precautions	29
3.4 Processor and Heatsink Installation.....	30
The 4th Gen Intel Xeon Scalable Processor	30
Overview of the CPU Socket	34
Overview of the Processor Carrier Assembly	35
Overview of the Processor Heatsink Module (PHM)	36
Creating the Processor Carrier Assembly.....	39
Creating the Processor Heatsink Module (PHM).....	43
Preparing the CPU Socket for Installation	45
Preparing to Install the PHM into the CPU Socket.....	46
Installing the PHM into the CPU Socket.....	48
Removing the PHM from the CPU Socket	50
Removing the Processor Carrier Assembly from the PHM	52
Removing the Processor from the Processor Carrier Assembly	53
3.5 Motherboard Installation.....	54
Tools Needed	54
Location of Mounting Holes	54
Installing the Motherboard.....	55
3.6 Memory Support and Installation	56
Memory Support.....	56
DDR5 Memory Support for 4th Gen Intel Xeon Scalable Processors	56
Memory Population Table for the 4th Gen Intel Xeon Scalable Processors.....	57
DIMM Installation	58
DIMM Removal	58
3.7 Motherboard Battery.....	59

3.8 Storage Drives.....	60
Drive Carriers.....	60
Drive Configuration	61
Installing Drives.....	62
Hot-Swap for NVMe Drives.....	64
Checking the Temperature of an NVMe Drive	65
Adding an Expansion Card	66
AIOM Card	69
3.9 System Cooling	70
Fans	70
Installing the Air Shroud.....	72
Checking the Airflow	72
3.10 Power Supply	73
3.11 Cable Routing Diagram.....	74
NVMe and SATA	74
NVMe and SAS via onboard 3808 Card.....	75
<i>Chapter 4 Motherboard Connections</i>	
4.1 Power Connections	76
4.2 Headers and Connectors	77
4.3 Input/Output Ports	79
4.4 Jumpers.....	81
How Jumpers Work.....	81
4.5 LED Indicators.....	83
<i>Chapter 5 Software</i>	
5.1 Microsoft Windows OS Installation.....	84
5.2 Driver Installation.....	86
5.3 SuperDoctor® 5.....	87
5.4 BMC.....	88
BMC ADMIN User password.....	88
<i>Chapter 6 Optional Components</i>	
6.1 Optional Parts List.....	89
6.2 M.2 NVMe Carrier Card	89
6.3 GPU Support.....	89

6.4 Intel Virtual RAID on CPU (VROC).....	90
Requirements and Restrictions	90
Supported SSDs and Operating Systems	90
Additional Information	91
Hardware Key	91
Configuring Intel VMD	92
Configuring VMD Manually.....	92
Creating NVMe RAID Configurations.....	96
Status Indications	97
Hot-Swap Drives	97
Hot-unplug	97
Hot-plug	97
Related Information Links	97
<i>Chapter 7 Troubleshooting and Support</i>	
7.1 Information Resources	98
Website	98
Direct Links for the SYS-621BT-H Series System	98
Direct Links for General Support and Information	99
7.2 Baseboard Management Controller (BMC).....	99
7.3 Troubleshooting Procedures	100
Before Power On	100
No Power	100
No Video	100
System Boot Failure	101
Memory Errors	101
Losing the System's Setup Configuration.....	101
When the System Becomes Unstable	102
7.4 Crash Dump Using BMC.....	103
7.5 UEFI BIOS Recovery	104
Overview	104
Recovering the UEFI BIOS Image.....	104
Recovering the Main BIOS Block with a USB Device.....	104

7.6 Where to Get Replacement Components109

7.7 Reporting an Issue109

 Technical Support Procedures109

 Returning Merchandise for Service.....110

 Vendor Support Filing System110

7.8 Feedback.....110

7.9 Contacting Supermicro.....111

Appendix A Standardized Warning Statements for AC Systems

Appendix B System Specifications

Contacting Supermicro

Headquarters

Address: Super Micro Computer, Inc.
980 Rock Ave.
San Jose, CA 95131 U.S.A.

Tel: +1 (408) 503-8000

Fax: +1 (408) 503-8008

Email: marketing@supermicro.com (General Information)
Sales-USA@supermicro.com (Sales Inquiries)
Government_Sales-USA@supermicro.com (Gov. Sales Inquiries)
support@supermicro.com (Technical Support)
RMA@supermicro.com (RMA Support)
Webmaster@supermicro.com (Webmaster)

Website: www.supermicro.com

Europe

Address: Super Micro Computer B.V.
Het Sterrenbeeld 28, 5215 ML
's-Hertogenbosch, The Netherlands

Tel: +31 (0) 73-6400390

Fax: +31 (0) 73-6416525

Email: Sales_Europe@supermicro.com (Sales Inquiries)
Support_Europe@supermicro.com (Technical Support)
RMA_Europe@supermicro.com (RMA Support)

Website: www.supermicro.nl

Asia-Pacific

Address: Super Micro Computer, Inc.
3F, No. 150, Jian 1st Rd.
Zhonghe Dist., New Taipei City 235
Taiwan (R.O.C)

Tel: +886-(2) 8226-3990

Fax: +886-(2) 8226-3992

Email: Sales-Asia@supermicro.com.tw (Sales Inquiries)
Support@supermicro.com.tw (Technical Support)
RMA@supermicro.com.tw (RMA Support)

Website: www.supermicro.com.tw

Chapter 1

Introduction

1.1 Overview

This chapter provides a brief outline of the functions and features of the SuperServer SYS-621BT-H Series. It provides four nodes for efficient power sharing, OCP 3.0 interfaces, and an optional M.2 NVMe physical RAID controller. The SuperServer [SYS-621BT-H Series](#) is based on the [X13DET-B](#) motherboard and the CSE-827BQ2-R3K04P chassis. An overview of the system is listed below.

System Overview	
Motherboard (per node)	X13DET-B
Chassis	CSE-827BQ2-R3K04P
Processor Support (per node)	Supports dual 4 th Gen Intel Xeon Scalable Processors (in Socket E LGA 4677) with four UPIs (16 GT/s max.) and a TDP (Thermal Design Power) up to 350 W. This motherboard supports SP XCC, SP MCC and HBM CPU SKUs.
Chipset	Intel C741 PCH
Memory (per node)	Supports up to 4 TB RDIMM DDR5 (288-pin) ECC memory with speeds up to 4800 MT/s in 16 DIMM slots.
Drive Support (per node)	Front hot-swappable drives include: SYS-621BT-HNTR: 2 LFF Gen5 NVMe/SATA drives and 1 LFF Gen4 NVMe/SATA drive SYS-621BT-HNC8R: 2 LFF Gen5 NVMe/SAS drives and 1 LFF Gen4 NVMe/SAS drive Internal M.2 drives per node include: Default carrier with two M.2 NVMe SSDs Optional carrier with two M.2 NVMe SSDs and Marvell HW RAID Internal Connector: VROC key header
Expansion Slots (per node)	Two PCIe 5.0 x16 slots
Networking (per node)	One AIOM or any compliant OCP 3.0 SFF Network Interface Card One dedicated LAN port for BMC (via AST2600 BMC RoT 2.0)
I/O Ports (per node)	Two USB 3.1 ports One VGA port
System Cooling	Four 8-cm mid-chassis fans. Two CPU heatsinks per node. One air shroud per node.
Power	Two redundant 3000W modules, 80Plus level Titanium power supplies Important: Power supply redundancy is supported only with a 240 VAC or 240 VDC input.
Form Factor	2U rackmount; (WxHxD) 17.6" x 3.5" 28.8" (447 x 88 x 730 mm)

Notes: A Quick Reference Guide can be found on the product page of the Supermicro website. The following safety models associated with the SYS-621BT-H Series have been certified as compliant with CSA or UL models: 827B-R30X13, 827B-30

1.2 System Features

The CSE-827BQ2-R3K04P is a 2U chassis that supports 12 front hot-swappable LFF drives and four rear hot-pluggable nodes.

Front View

The chassis front offers access to the storage drives, a control panel for each node, a pull-out service tag, and two thumbscrews.

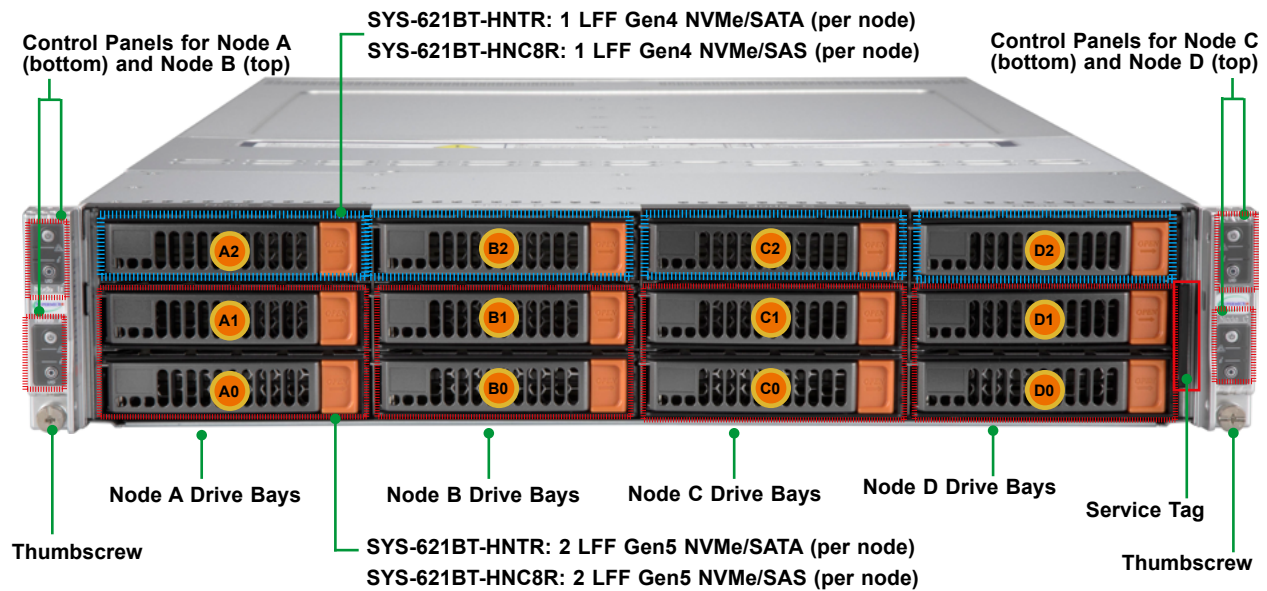

Figure 1-1. Front View

System Features: Front	
Feature	Description
Control Panels	Four control panels with labels for each node. The four control panels are located as follows: node A bottom left, node B top left, node C bottom right, and node D top right.
Service Tag	Pull-out service tag with BMC password label
Drive Bays	12 hot-swappable drive bays (three per node)
Thumbscrews	Two thumbscrews to secure the server onto the rack

Front View: SYS-621BT-HNTR

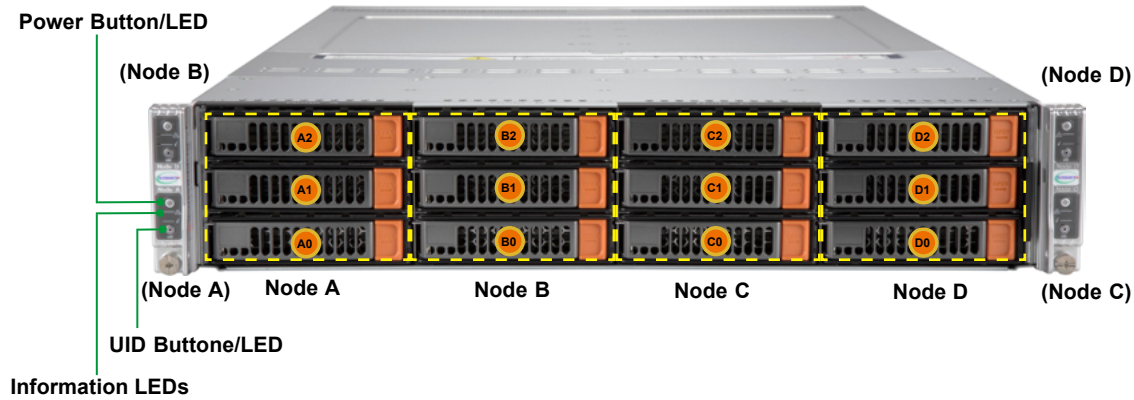

Figure 1-2. Front View: SYS-621BT-HNTR

Drive Bay (Node A-D)	Description
0 - 1	Two 3.5" Hot-Swap NVMe Gen5 (CPU1)/ SATA Drive Bays
2	One 3.5" Hot-Swap NVMe Gen4 (CPU2)/ SATA Drive Bays

Front View: SYS-621BT-HNC8R

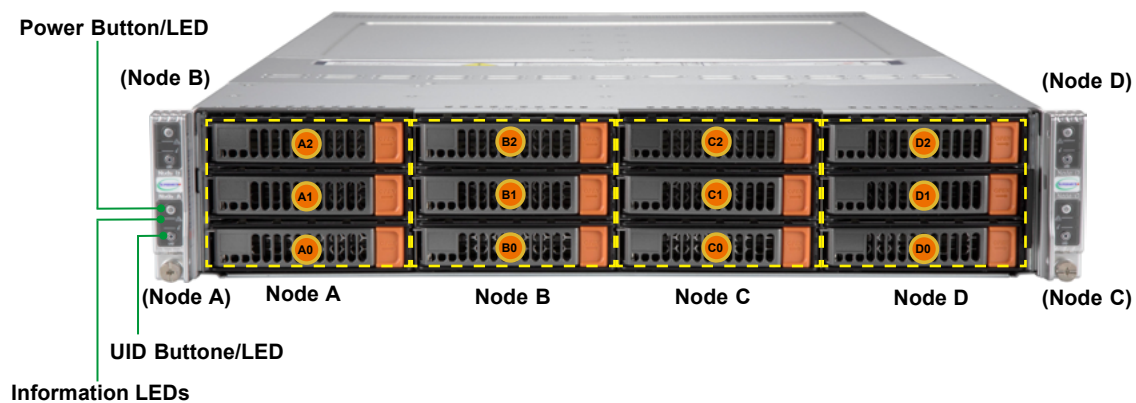

Figure 1-3. Front View: SYS-621BT-HNC8R

Drive Bay (Node A-D)	Description
0 - 1	Two 3.5" Hot-Swap NVMe Gen5 (CPU1)/ SAS Drive Bays
2	One 3.5" Hot-Swap NVMe Gen4 (CPU2)/ SAS Drive Bays

Control Panel

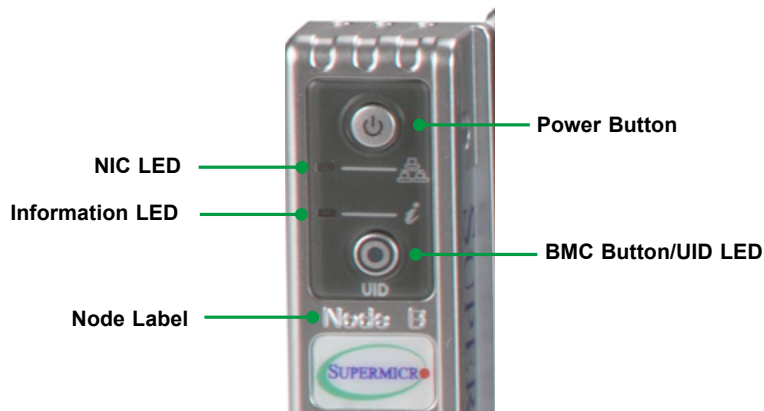

Figure 1-4. Control Panel (One Per Node)

Control Panel Features (Per Node)	
Feature	Description
Power Button	The main power switch applies or removes primary power from the power supply to the server but maintains standby power.
NIC LED	Indicates network activity on the LAN when flashing.
Information LED	Universal information LED (see table below for details).
BMC Button/ UID LED	The unit identification (UID) button turns on or off the blue light function of the Information LED and a blue LED on the rear of the chassis. These are used to locate the server in large racks and server banks.
Node Label	Label with the name of the node that is connected to the control panel. Labels for nodes A and C are above their control panel. Labels for nodes B and D are below their control panel.

Information LED	
Status	Description
Red, solid	An overheat condition has occurred.
Red, blinking at 1 Hz	Fan failure, check for an inoperative fan.
Red, blinking at 0.25 Hz	Power failure, check for a non-operational power supply.
Red, solid, with Power LED blinking green	Fault detected
Blue and red, blinking at 10 Hz	Recovery mode
Blue, solid	UID has been activated locally to locate the server in a rack environment.
Blue, blinking at 1Hz	UID has been activated using the BMC to locate the server in a rack environment.
Blue, blinking at 2Hz	BMC is resetting
Blue, blinking at 4Hz	BMC is setting factory defaults
Blue, blinking at 10 Hz with Power LED blinking green	BMC/BIOS firmware is updating

Rear View

The illustration below shows the features included on the rear of the chassis. Power supply modules display status lights.

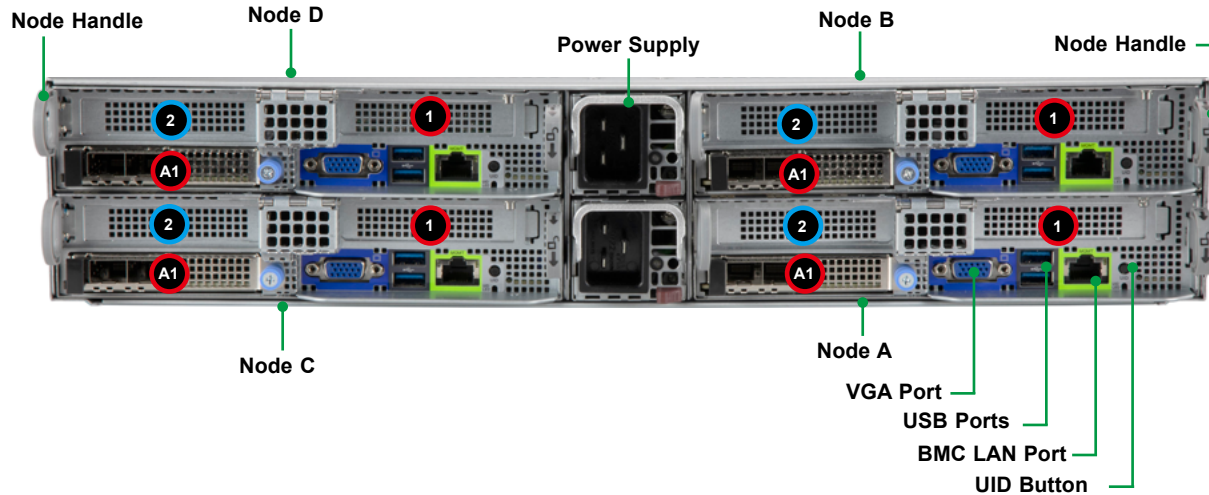





Figure 1-5. System: Rear View

System Features: Rear	
Feature	Description
Nodes A, B, C, D	Independent computing nodes
Power Supplies	Two redundant 3000 W Titanium Level power supplies Important: Power supply redundancy is supported only with a 240 VAC or 240 VDC input.
VGA Port	One video port
USB Ports	Two USB 3.1 ports
LAN Port	One dedicated BMC LAN port
Dual Function Switch	A switch that can function as either a UID LED switch or a BMC reset switch. See Chapter 4 for a description of the dual function switch.
Node Handles	Two handles per node supporting node tray removal

Expansion Slot Locations	
Slot (Node A-D)	Description
	AIOM Slot PCIe 5.0 x16
	PCIe 5.0 x16 low-profile slot
	PCIe 5.0 x16 low-profile slot

CPU1  CPU2 

1.3 System Architecture

This section shows the main components and the system block diagram.

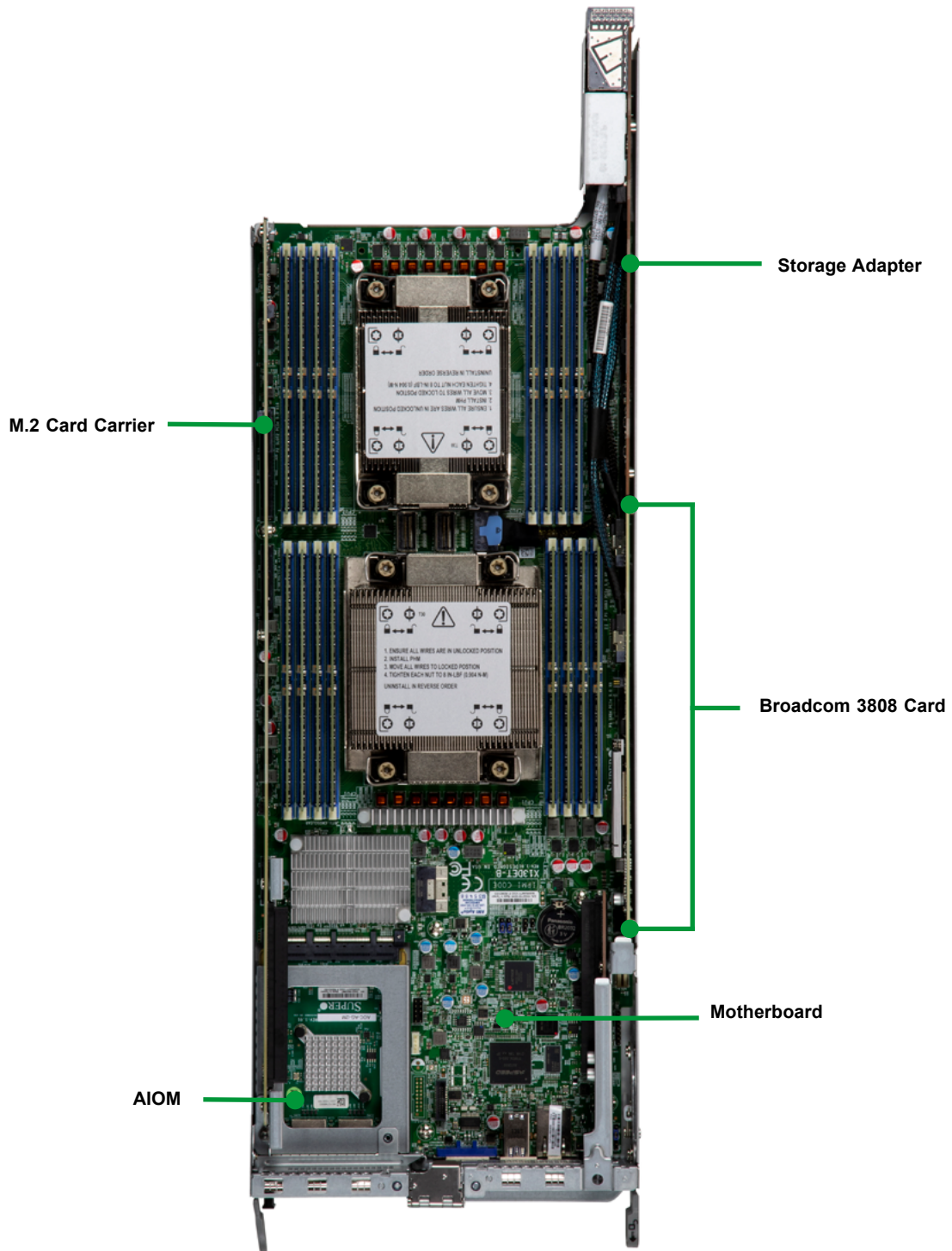

Figure 1-6. SYS-621BT-HNTR/-HNC8R Main Component

1.4 Motherboard Layout

Below is a layout of the X13DET-B motherboard with jumper, connector and LED locations shown. See the table on the following page for descriptions. For detailed descriptions, pinout information and jumper settings, refer to [Chapter 4](#) or the [Motherboard Manual](#).

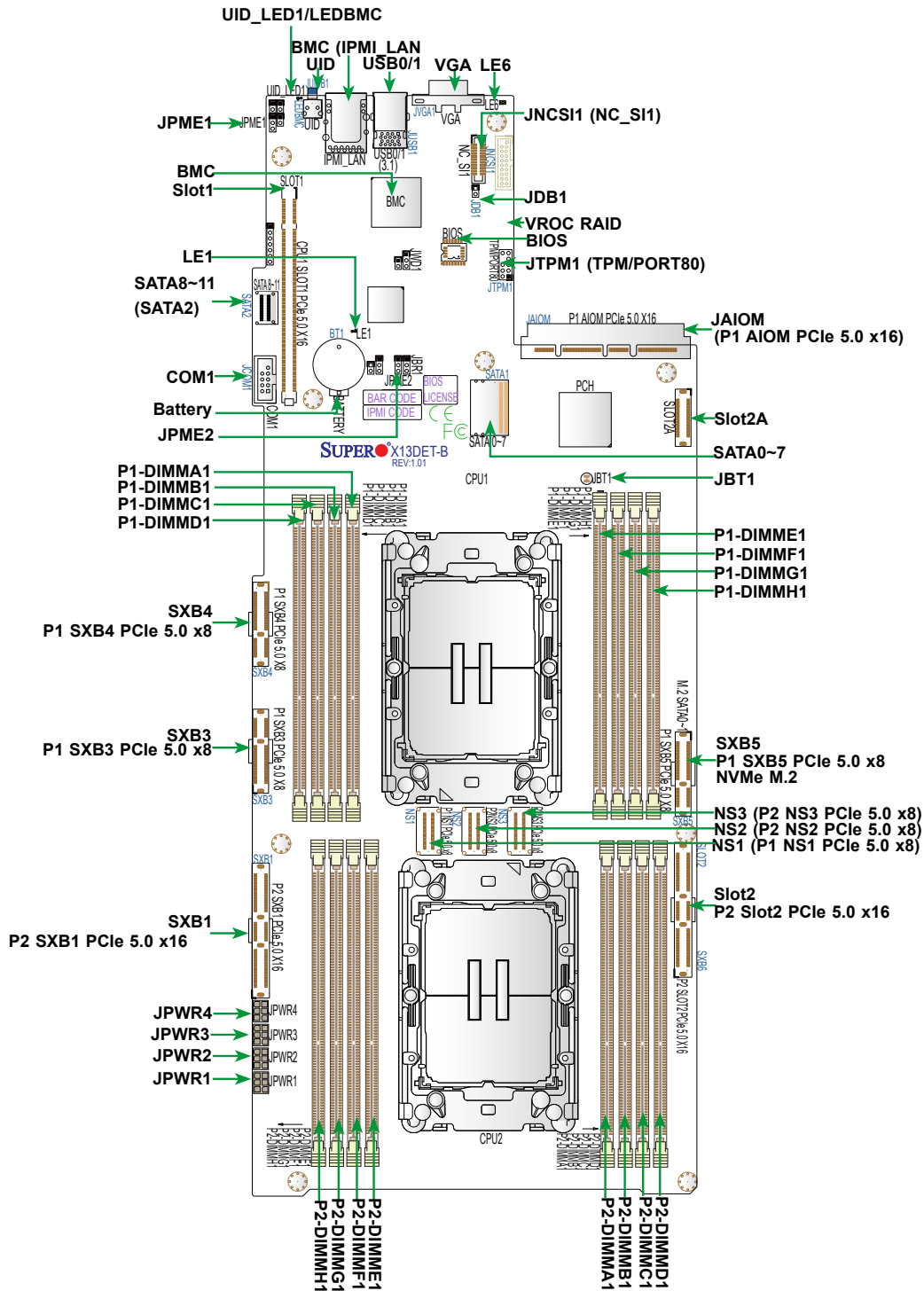

Figure 1-8. Motherboard Layout

Quick Reference Table

Jumper	Description	Jumper Setting
JBT1	CMOS Clear	Open (Normal)
JPME1	ME Recovery	Pins 1/2: Normal
JPME2	ME (Manufacture Mode) Select	Pins 1/2: ME Mode

LED	Description	Status
LE1	CPLD Heartbeat LED	On: Complex Programmable Logical Device (CPLD) Normal (Active)
LE6	Power Status LED	Green: Power On Amber: Standby Power Red: Power Failure
UID_LED1/ LEDBMC	Rear Unit Identifier (UID) LED/BMC Heartbeat LED	Solid Blue (working as a UID LED): Unit Identified Blinking Green (working as a BMC LED): BMC Normal (Active) Solid Green: During BMC Reset or during a Cold Reboot

Connector	Description
Battery (BT1)	Onboard battery
BMC_LAN (IPMI_LAN1)	Dedicated BMC LAN port on the I/O backplane
COM1 (JCOM1)	Serial/COM port header
JAIOM	Supermicro Advanced input/output Module (AIOM) PCIe 5.0 x16 slot supported by CPU1
JNCSI1	NC-SI (Network Controller Sideband Interface) connector (See Note 1 below.)
JTPM1	Trusted Platform Module/Port 80 connector
JPWR1~JPWR4	6-pin power connectors (1~4)
NS1	P1 NS1 PCIe 5.0 x8 connector supported by CPU1
NS2	P2 NS2 PCIe 5.0 x8 connector supported by CPU2
NS3	P2 NS3 PCIe 5.0 x8 connector supported by CPU2
Slot1	P1 Slot1 PCIe 5.0 x16 supported by CPU1
Slot2 + Slot2A	P2 Slot2/Slot2A PCIe 5.0 x16 to support riser card(s)
SXB1	P2 SXB1 PCIe 5.0 x16 supported by CPU2
SXB3	P1 SXB3 PCIe 5.0 x8 supported by CPU1
SXB4	P1 SXB4 PCIe 5.0 x8 supported by CPU1
SXB5 (NVMe M.2)	P1 SXB5 PCIe 5.0 x8 for two NVMe M.2 devices in the M-Key 2280 or 22110 format (depending on the type of riser card used) supported by CPU1 (See Note 2)
SATA 0~7 (SATA1)	SATA connector with support of eight Intel® PCH SATA 3.0 connections (RAID 0, RAID 1, RAID 5, and RAID 10 supported)

Note 1: For details on how to configure Network Interface Card (NIC) settings, please refer to the Network Interface Card Configuration User's Guide posted on our website under the link: <http://www.supermicro.com/support/manuals/>.

Note 2: The SXB5 slot supports the SCC-P2HM2G4-B1 and the SCC-A2NM2241G3-B1. The SCC-P2HM2G4-B1 supports two NVMe M.2 devices (up to Gen 4) in the 22110 form factor, and the SCC-A2NM2241G3-B1 supports two NVMe M.2 devices (up to Gen 3) in the 2280 form factor.

SATA 8~11 (SATA2)	SATA connector with four SATA connections (SATA 8~11)
UID Button (JUIDB1)	Unit Identifier/BMC Reset switch/button on the rear I/O panel
USB0/1 (3.1) (JUSB1)	USB 3.1 connector on the rear I/O panel for two USB parts (Port0/Port1)
VGA (JVGA1)	Rear VGA connector
VROC RAID Key (JEK1)	Intel VROC key header for NVMe RAID support (See Note 2 below.)

Note 1: For details on how to configure Network Interface Card (NIC) settings, please refer to the Network Interface Card Configuration User's Guide posted on our website under the link: <http://www.supermicro.com/support/manuals/>.

Note 2: For detailed instructions on how to configure VROC RAID settings, please refer to the VROC RAID Configuration User's Guide posted on the web page under the link: <http://www.supermicro.com/support/manuals/>.

Chapter 2

Server Installation

2.1 Overview

This chapter provides advice and instructions for mounting your system in a server rack. If your system is not already fully integrated with processors, system memory etc., refer to [Chapter 3](#) for details on installing those specific components.

Caution: Electrostatic Discharge (ESD) can damage electronic components. To prevent such damage to PCBs (printed circuit boards), it is important to use a grounded wrist strap, handle all PCBs by their edges and keep them in anti-static bags when not in use.

2.2 Unpacking the System

Inspect the box in which the SuperServer 621BT-H Series was shipped, and note if it was damaged in any way. If any equipment appears damaged, file a damage claim with the carrier who delivered it.

Decide on a suitable location for the rack unit that will hold the server. It should be situated in a clean, dust-free area that is well ventilated. Avoid areas where heat, electrical noise and electromagnetic fields are generated. It will also require a grounded AC power outlet nearby. Be sure to read the precautions and considerations noted in [Appendix A](#).

2.3 Preparing for Setup

The box in which the system was shipped should include the rackmount hardware needed to install it into the rack. Please read this section in its entirety before you begin the installation.

Choosing a Setup Location

- The system should be situated in a clean, dust-free area that is well ventilated. Avoid areas where heat, electrical noise and electromagnetic fields are generated.
- Leave enough clearance in front of the rack so that you can open the front door completely (approximately 25 inches) and approximately 30 inches of clearance in the back of the rack to allow sufficient space for airflow and access when servicing.
- This product should be installed only in a Restricted Access Location (dedicated equipment rooms, service closets, etc.).

- This product is not suitable for use with visual display workplace devices according to §2 of the German Ordinance for Work with Visual Display Units.

Rack Precautions

- Ensure that the leveling jacks on the bottom of the rack are extended to the floor so that the full weight of the rack rests on them.
- In single rack installations, stabilizers should be attached to the rack. In multiple rack installations, the racks should be coupled together.
- Always make sure the rack is stable before extending a server or other component from the rack.
- You should extend only one server or component at a time - extending two or more simultaneously may cause the rack to become unstable.

Server Precautions

- Review the electrical and general safety precautions in [Appendix A](#).
- Determine the placement of each component in the rack before you install the rails.
- Install the heaviest server components at the bottom of the rack first and then work your way up.
- Use a regulating uninterruptible power supply (UPS) to protect the server from power surges and voltage spikes and to keep your system operating in case of a power failure.
- Allow any drives and power supply modules to cool before touching them.
- When not servicing, always keep the front door of the rack and all covers/panels on the servers closed to maintain proper cooling.
- To maintain proper cooling, always keep all chassis panels closed and all SATA carriers installed when not being serviced.

Rack Mounting Considerations

Ambient Operating Temperature

If installed in a closed or multi-unit rack assembly, the ambient operating temperature of the rack environment may be greater than the room's ambient temperature. Therefore, consideration should be given to installing the equipment in an environment compatible with the manufacturer's maximum rated ambient temperature (TMRA).

Airflow

Equipment should be mounted into a rack so that the amount of airflow required for safe operation is not compromised.

Mechanical Loading

Equipment should be mounted into a rack so that a hazardous condition does not arise due to uneven mechanical loading.

Circuit Overloading

Consideration should be given to the connection of the equipment to the power supply circuitry and the effect that any possible overloading of circuits might have on overcurrent protection and power supply wiring. Appropriate consideration of equipment nameplate ratings should be used when addressing this concern.

Reliable Ground

A reliable ground must be maintained at all times. To ensure this, the rack itself should be grounded. Particular attention should be given to power supply connections other than the direct connections to the branch circuit (i.e. the use of power strips, etc.).

Important: To prevent bodily injury when mounting or servicing this unit in a rack, you must take special precautions to ensure that the system remains stable. The following guidelines are provided to ensure your safety:

- This unit should be mounted at the bottom of the rack if it is the only unit in the rack.
- When mounting this unit in a partially filled rack, load the rack from the bottom to the top with the heaviest component at the bottom of the rack.
- If the rack is provided with stabilizing devices, install the stabilizers before mounting or servicing the unit in the rack.
- Slide rail mounted equipment is not to be used as a shelf or a work space.

Important: Do not pick up the server with the front handles. They are designed to pull the system from a rack only.

Important: Slide rail mounted equipment is not to be used as a shelf or a work space.

2.4 Rack Mounting Instructions

This section provides information on installing the chassis into a rack unit with the rails provided. There are a variety of rack units on the market, which may mean that the assembly procedure will differ slightly from the instructions provided. You should also refer to the installation instructions that came with the rack unit you are using.

Note: This rail will fit a rack between 28" and 33.5" deep.

Overview of the Rack Rails

The package includes two rail assemblies. Each is specifically designed for the left or right side of the chassis, and so marked. Each rail consists of two sections: a front section which secures to the front post of the rack and a rear section which adjusts in length and secures to the rear post of the rack.

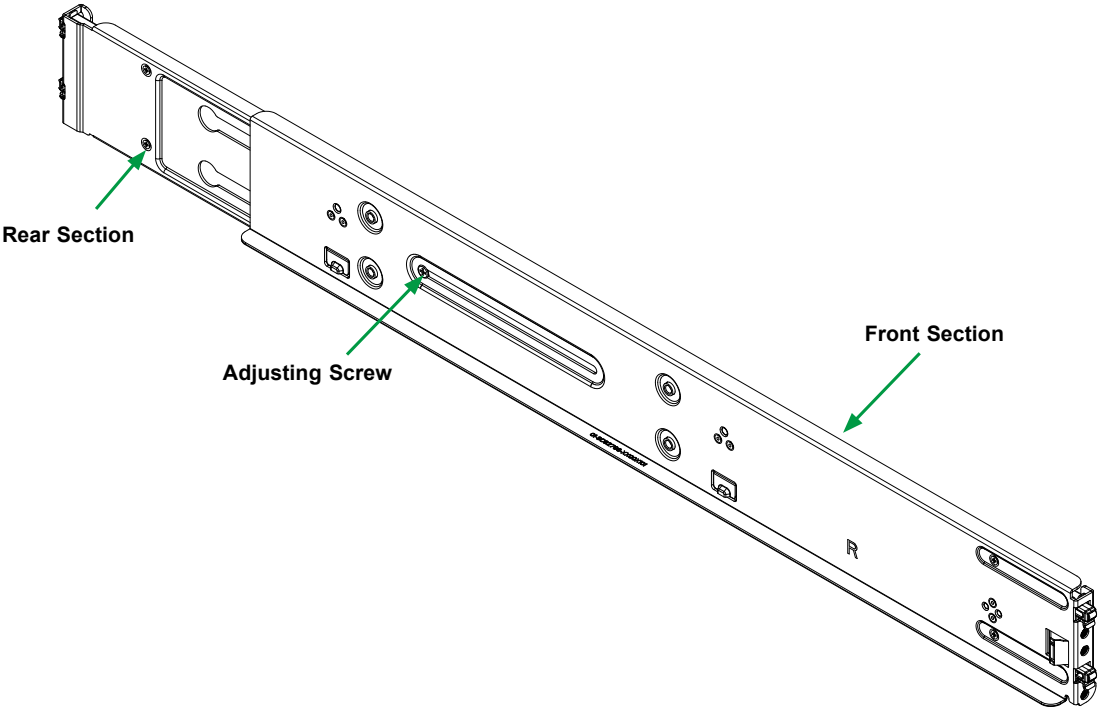

**Figure 2-1. Rackmount Rail
(Right rail assembly shown)**

Adjusting the Rail Length

Each rail assembly has a locking screw to adjust the length of the rail to fit the depth of your rack.

Installing the Rails on a Rack

1. Loosen the adjusting screw to allow the rear section to slide in the front section.
2. Push the small hooks on the front section of the rail into the holes on the front post of the rack and then down, until the spring-loaded pegs snap into the rack holes. Secure the rail to the rack with screws.
3. Pull out the rear section of the outer rail, adjusting the length until it fits within the posts of the rack and align the small hooks with the appropriate holes on the rear post of the rack. Be sure the rail is level, then mount the rear section onto the rack. Secure the rail with screws.
4. Tighten the adjusting screw.

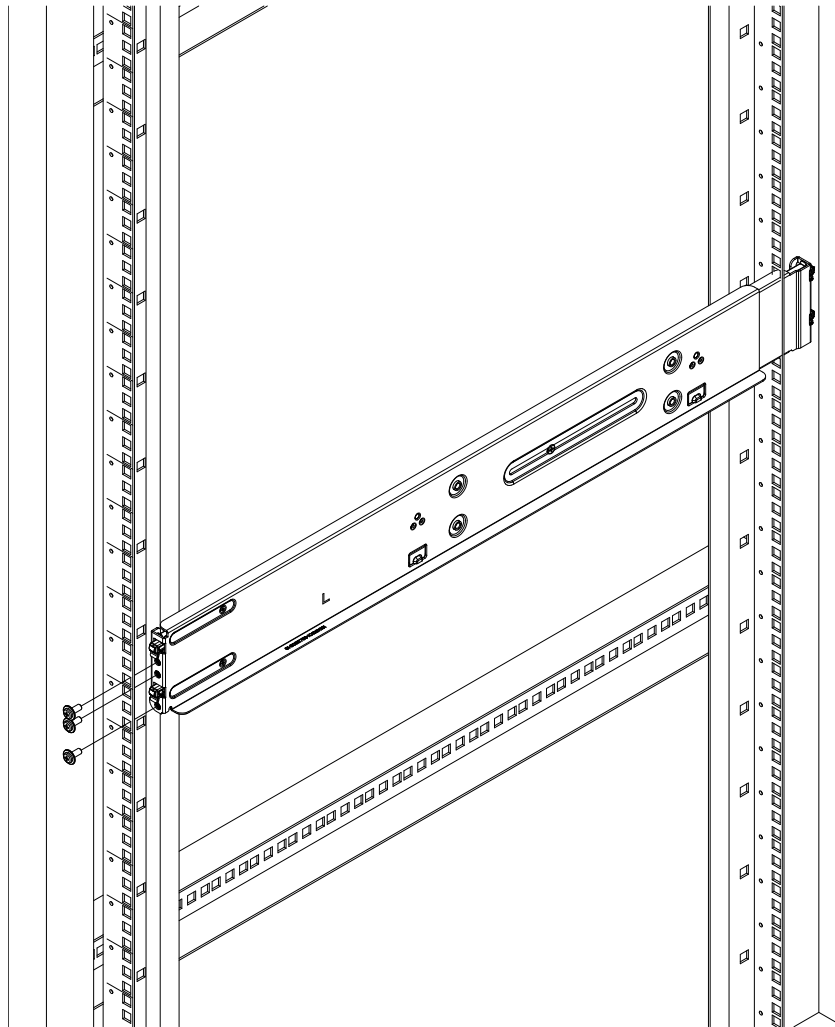

**Figure 2-2. Attaching the Rail Front to the Rack
(Left rail shown)**

Note: Figures are for illustrative purposes only. Always install servers into racks from the bottom up.

Chassis Installation

Slide the chassis into the rack so that the bottom of the chassis slides onto the bottom lip of the rails.

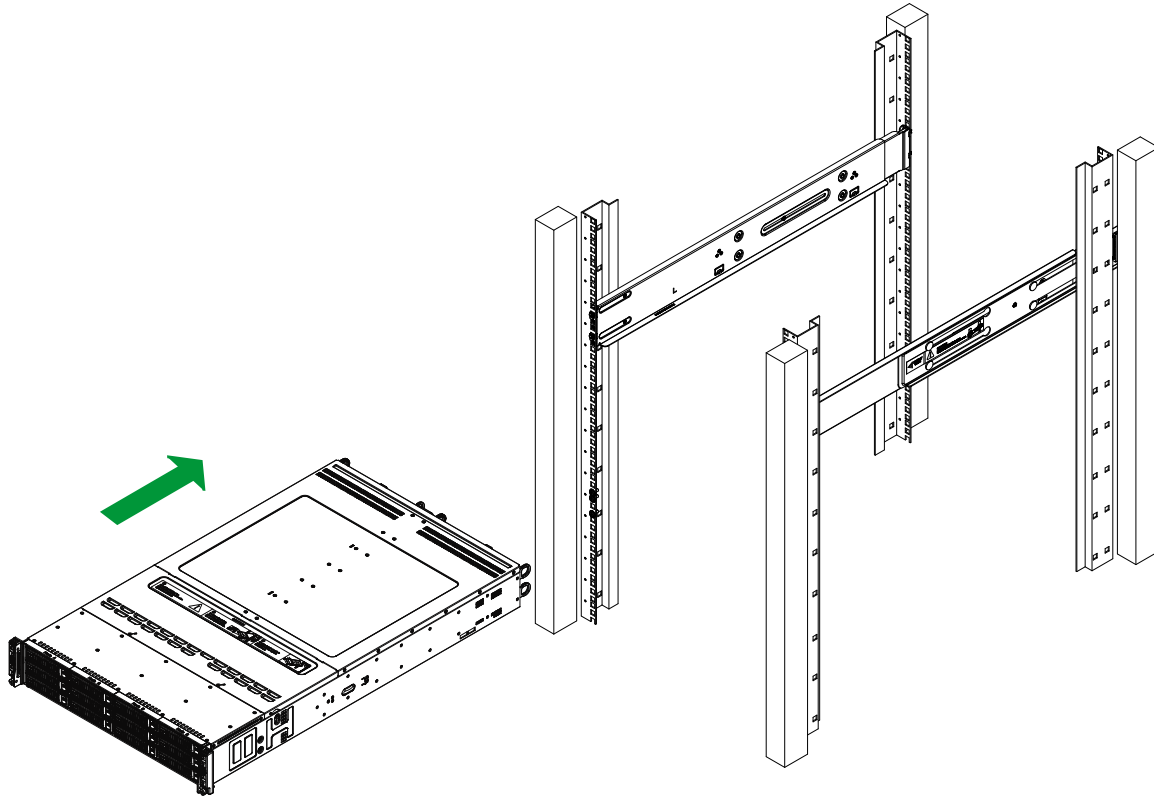

Figure 2-3. Sliding the Chassis into the Rack

Important: Stability hazard. The rack stabilizing mechanism must be in place, or the rack must be bolted to the floor before you slide the unit out for servicing. Failure to stabilize the rack can cause the rack to tip over.

Chapter 3

Maintenance and Component Installation

This chapter provides instructions on installing and replacing main system components. To prevent compatibility issues, only use components that match the specifications and/or part numbers given.

Installation or replacement of most components require that power first be removed from the system. Please follow the procedures given in each section.

3.1 Removing Power

Before performing some setup or maintenance tasks, use the following procedure to ensure that power has been removed from the system.

Removing Power from a Node

- Use the operating system to power down the node.

Removing Power from the System

1. Use the operating system to power down all nodes.
2. Grasp the head of each power cord and gently pull it out of the back of the power supply.
3. Disconnect the cords from the power strip or wall outlet.

3.2 Accessing the System

Removing a Computing Node Drawer

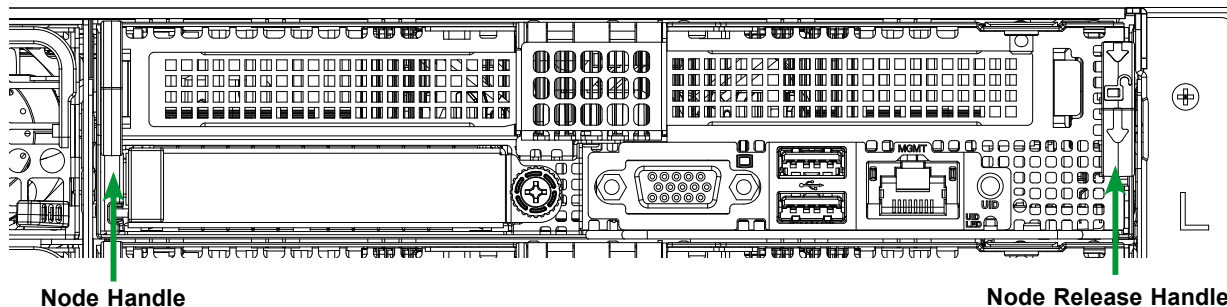

Figure 3-1. Removing a Node Tray

Removing a Node

1. Use the operating system to power down the node.
2. Remove any cables attached to the outside of the node.
3. Pull down the node release handle (the handle with the lock and arrow icon) and use both handles to slide the node out the chassis rear.

Removing the Chassis Cover

You can access some chassis components, such as fans, by removing the cover.

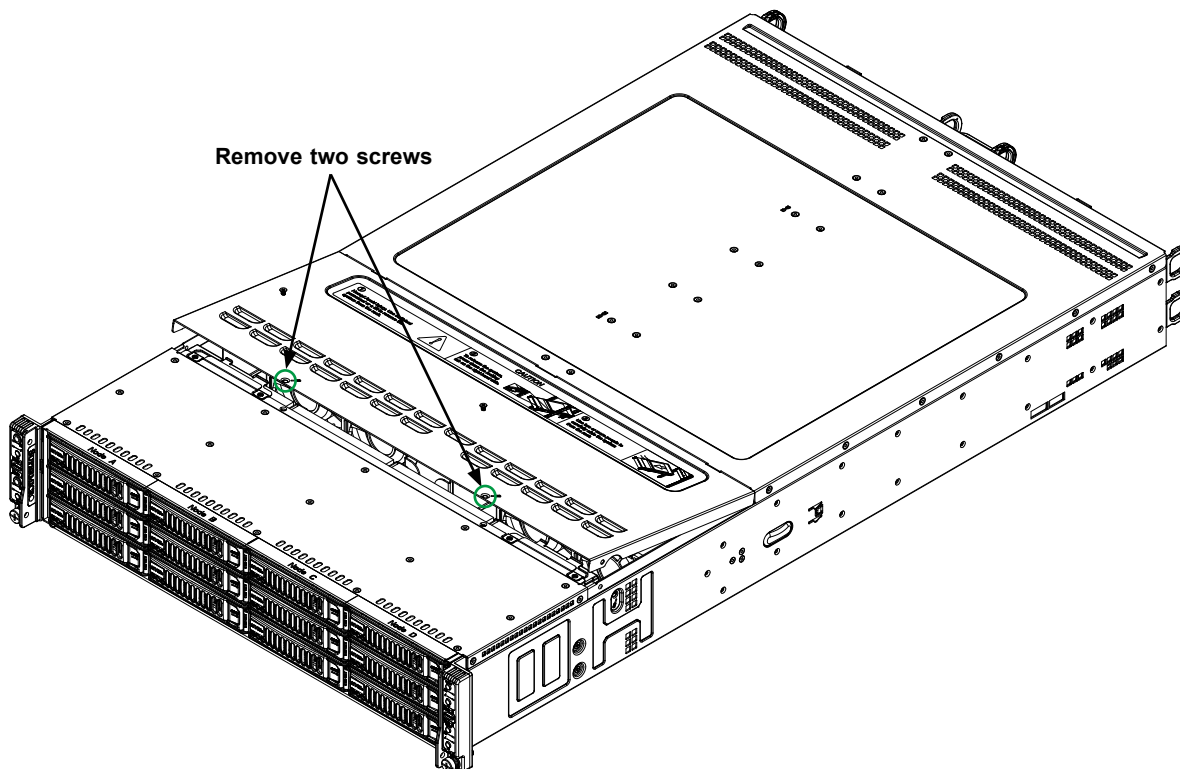

Figure 3-2. Removing the Chassis Cover

Removing the Chassis Cover

The chassis top cover can be lifted off after removing two screws.

Important: Except for short periods of time, do not operate the server without the cover in place. It provides proper airflow to prevent overheating.

3.3 Static-Sensitive Devices

Electrostatic Discharge (ESD) can damage electronic components. To avoid damaging your motherboard, it is important to handle it very carefully. The following measures are generally sufficient to protect the system PCBs from ESD.

Precautions

- Use a grounded wrist strap designed to prevent static discharge.
- Touch a grounded metal object before removing any PCB (printed circuit board) from its antistatic bag.
- Handle PCBs by their edges only; do not touch its components, peripheral chips, memory modules or gold contacts.
- When handling chips or modules, avoid touching their pins.
- Put the PCBs back into their antistatic bags when not in use.
- Use only the correct type of onboard CMOS battery. Do not install the onboard battery upside down to avoid possible explosion.

3.4 Processor and Heatsink Installation

The processor (CPU) and processor carrier should be assembled together first to form the processor carrier assembly. This assembly will be then attached to the heatsink to form the processor heatsink module (PHM) before being installed into the CPU socket. Before installation, be sure to perform the following steps below:

- Please carefully follow the instructions given on the previous page to avoid ESD-related damages.
- Unplug the AC power cords from all power supplies after shutting down the system.
- Check that the plastic protective cover is on the CPU socket, and none of the socket pins are bent. If they are, contact your retailer.
- When handling the processor, avoid touching or placing direct pressure on the LGA lands (gold contacts). Improper installation or socket misalignment can cause serious damage to the processor or CPU socket, which may require manufacturer repairs.
- Thermal grease is pre-applied on a new heatsink. No additional thermal grease is needed.
- Refer to the Supermicro website for updates on processor and memory support.
- All graphics in this manual are for illustrations only. Your components may look different.

The 4th Gen Intel Xeon Scalable Processor

Processor Top View

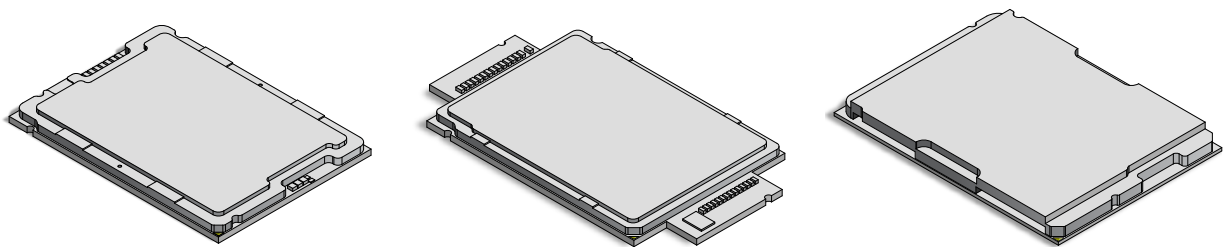

SP XCC

HBM

SP MCC

1. The 4th Gen Intel Xeon Scalable Processor

Processor Top View

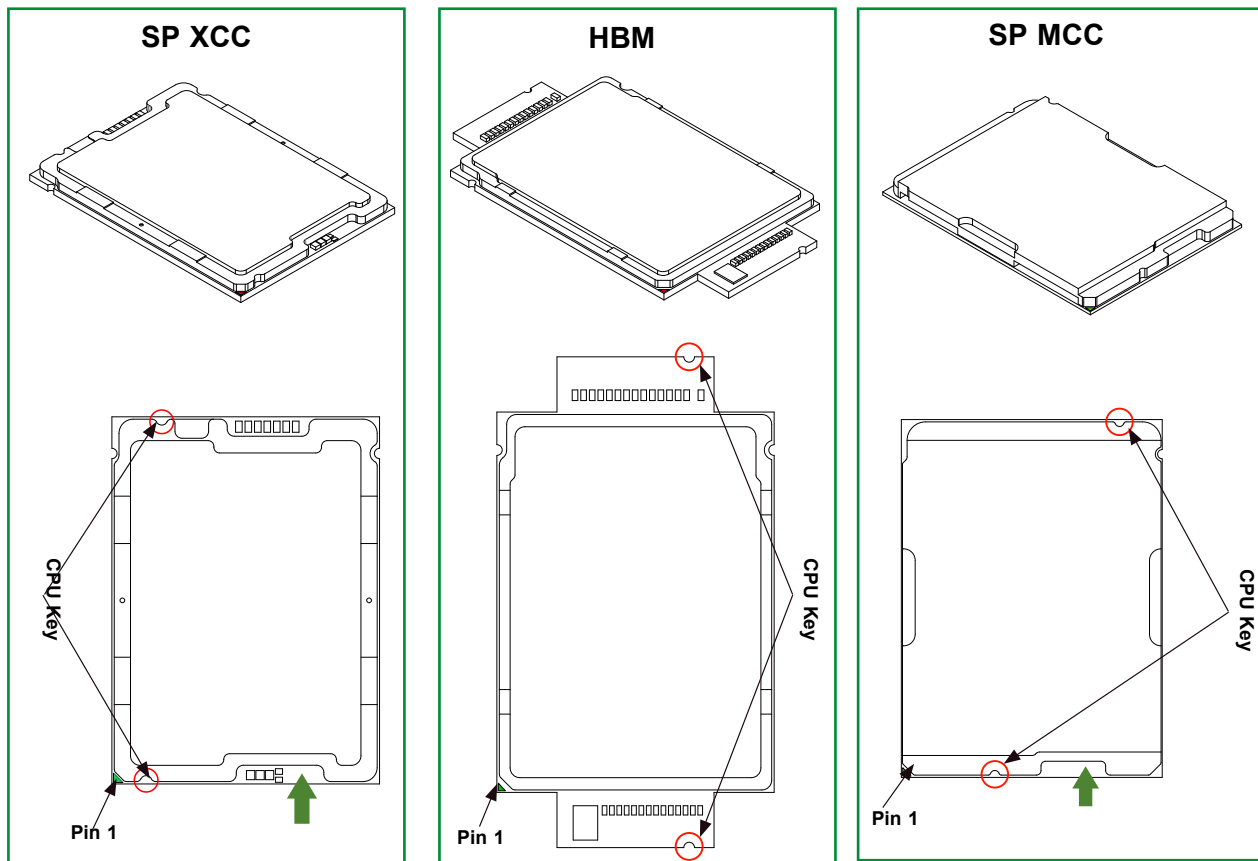

Processor Bottom View

2. The Processor Carrier

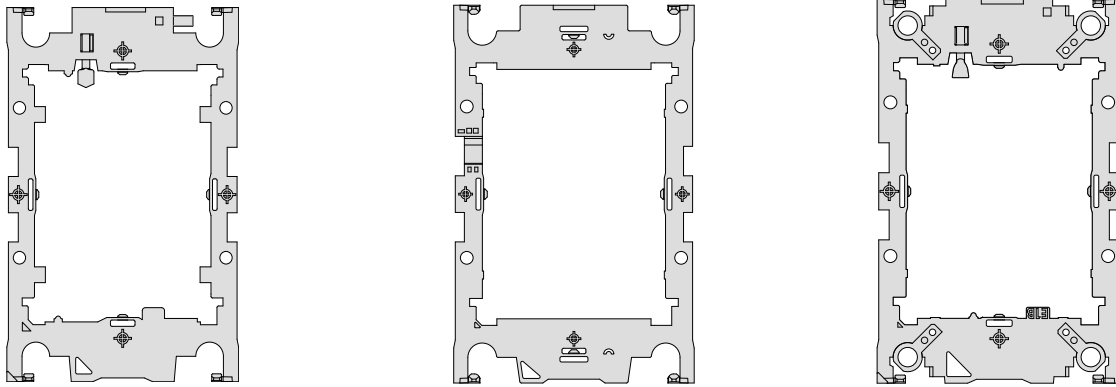
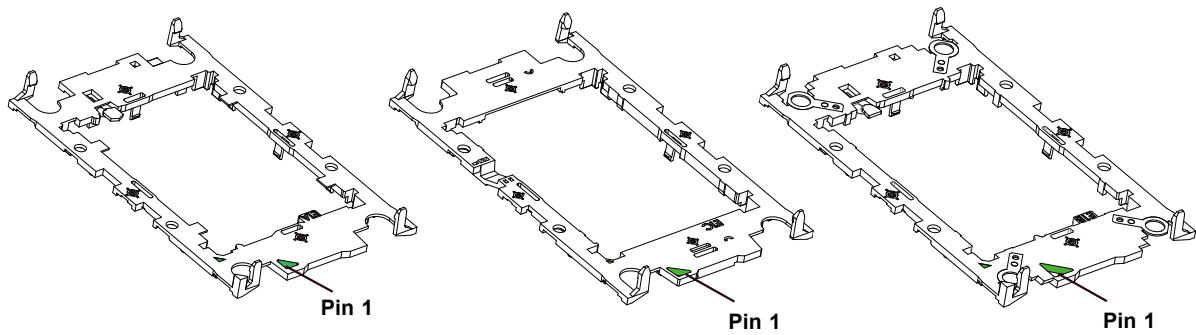

Carrier Top View

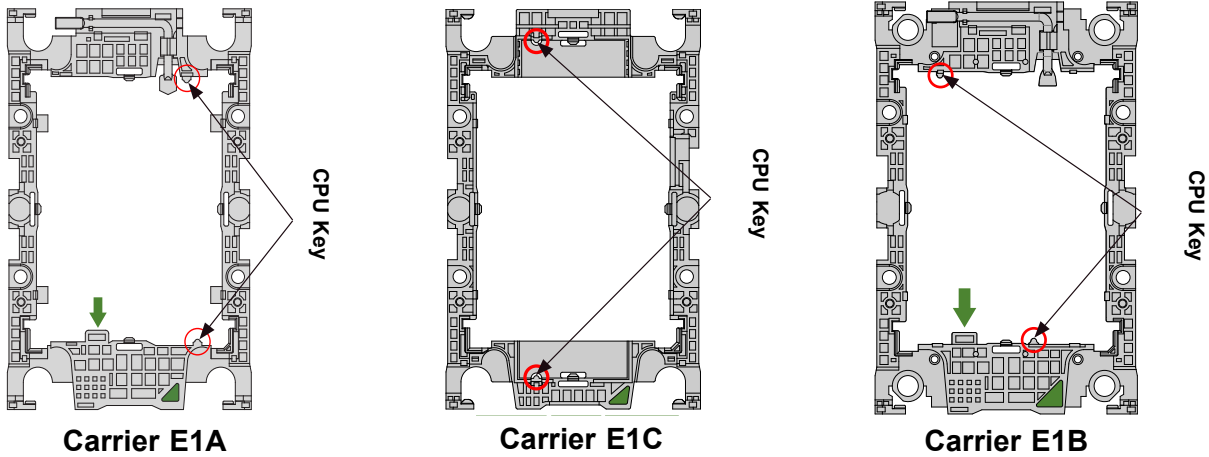

Carrier E1A

Carrier E1C

Carrier E1B



Carrier Bottom View

Note 1: The 4th Gen Intel® Xeon® Scalable Processor comes with three CPU SKUs: SP XCC, SP MCC, and HBM. Each CPU SKU supports a specific carrier. The SP XCC CPU supports Carrier E1A; HBM CPU supports Carrier E1C, and SP MCC, Carrier E1B.

Note 2: Please be sure to use processors of the same SKU on this motherboard.

3. Heatsink

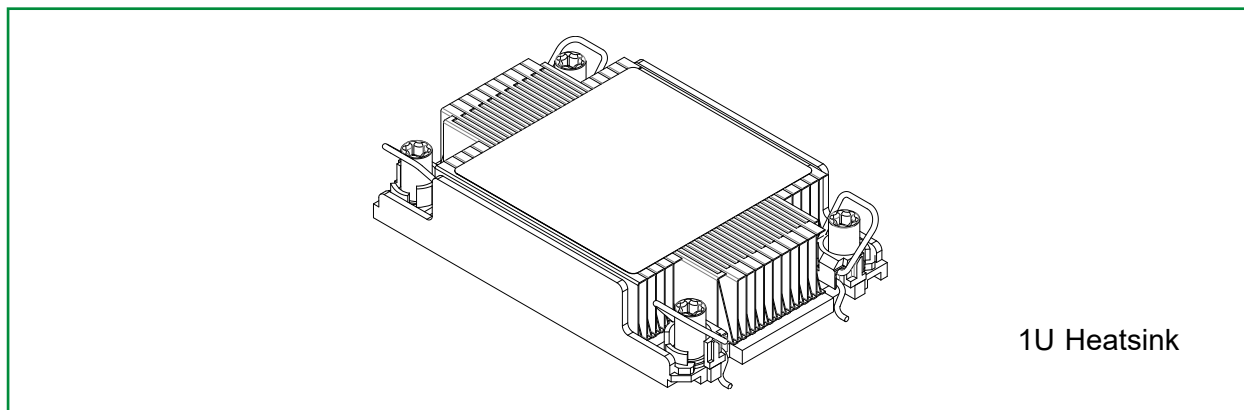

Note 1: Exercise extreme care when handling the heatsink. Pay attention to the edges of heatsink fins, which can be sharp! To avoid damaging the heatsink, please do not apply excessive force on the fins.

Note 2: This installation section provides instructions on how to install 1U heatsink, which are supported by your system.

Overview of the CPU Socket

The CPU socket is protected by a plastic protective cover.

Plastic Protective Cover

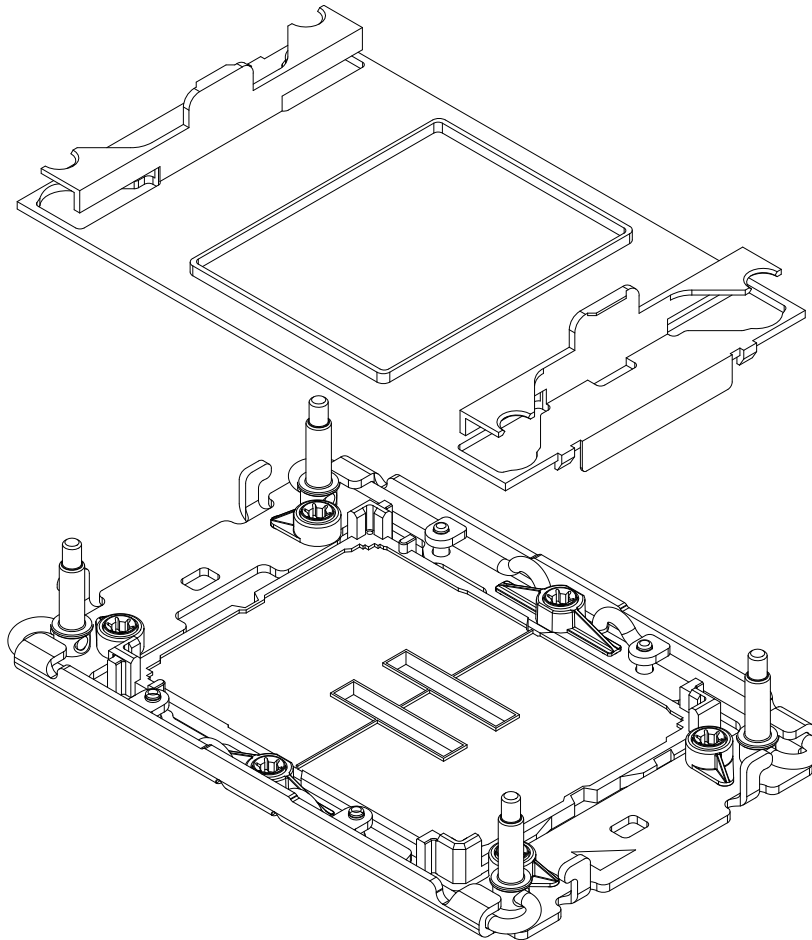

CPU Socket

Overview of the Processor Carrier Assembly

The processor carrier assembly contains a 4th Gen Intel Xeon Scalable processor and a processor carrier. Carefully follow the instructions given in the installation section to place a processor into the carrier to create a processor carrier.

The processor carrier assembly includes a processor and a carrier as shown below:

1. The 4th Gen Intel Xeon Scalable Processor (Component Side)

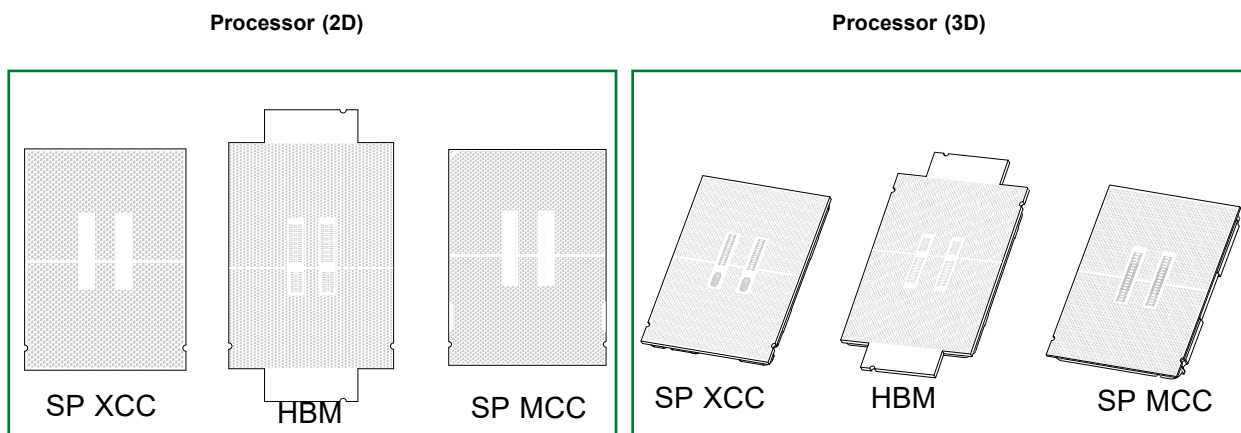

2. CPU Carrier (Top View)

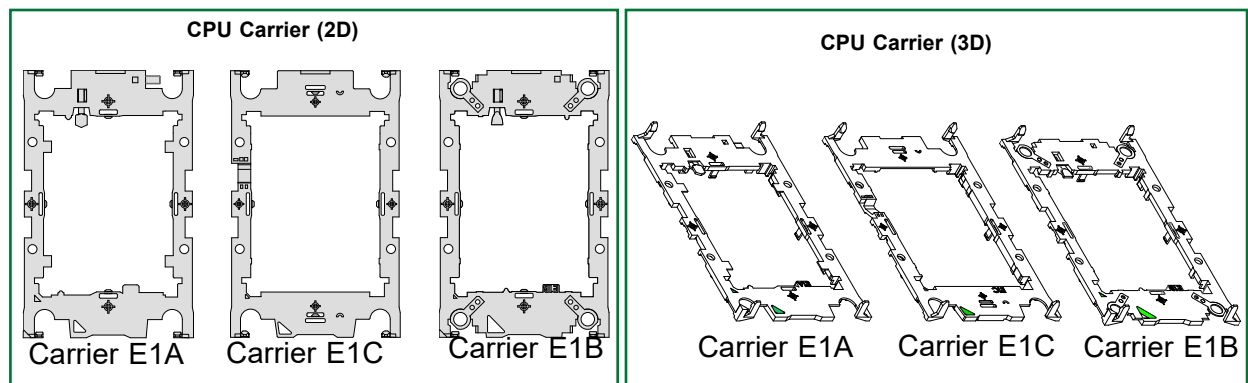

3. CPU Carrier Assembly (with Processor Seated inside the Carrier)

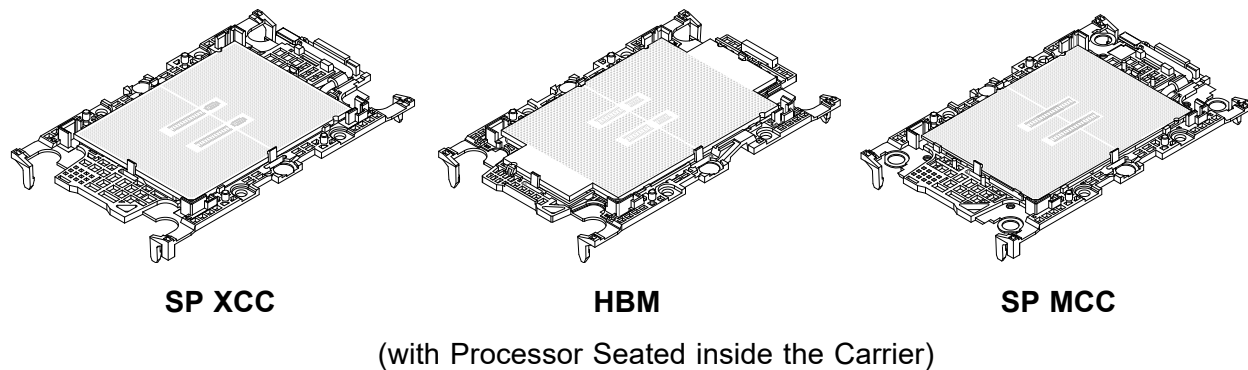

Overview of the Processor Heatsink Module (PHM)

The Processor Heatsink Module (PHM) contains a heatsink, a processor carrier, and a 4th Gen Intel Xeon Scalable processor.

1. Heatsink (Bottom View Shown Below)

1U Heatsink

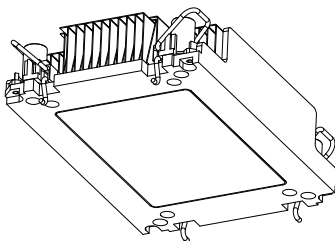

2. Processor Carrier E1A

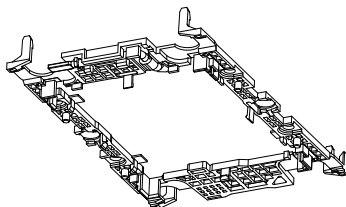

3. The 4th Gen Intel Xeon Scalable Processor (SP XCC) (Component Side Shown Below)

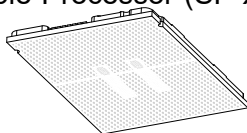

4. Processor Heatsink Module (PHM) (Bottom View Shown Below)

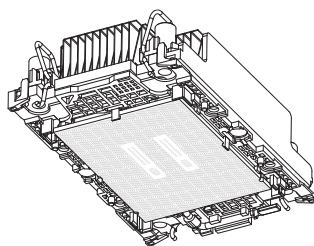

1U Heatsink

1. Heatsink (Bottom View Shown Below)

1U Heatsink

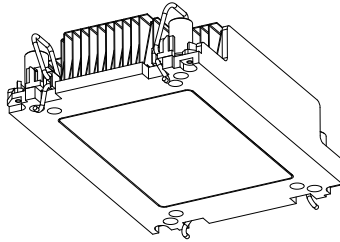

2. Processor Carrier E1C

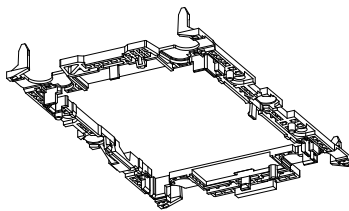

3. The 4th Gen Intel Xeon Scalable Processor (HBM) (Component Side)

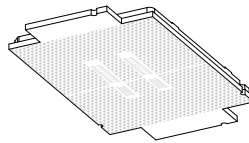

4. Processor Heatsink Module (PHM) (Bottom View Shown Below)

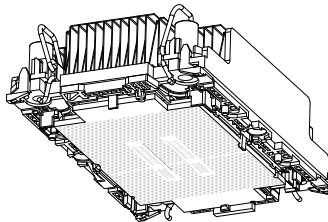

1U Heatsink

1. Heatsink (Bottom View Shown Below)

1U Heatsink

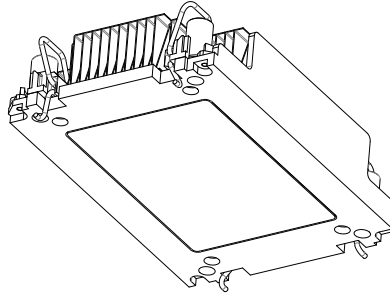

2. CPU Carrier E1B

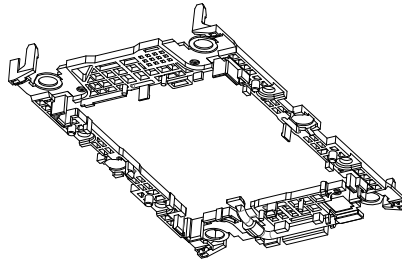

3. The 4th Gen Intel Xeon Scalable Processor (SP MCC) (Component Side Shown Below)

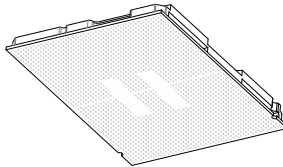

4. Processor Heatsink Module (PHM) (Bottom View Shown Below)

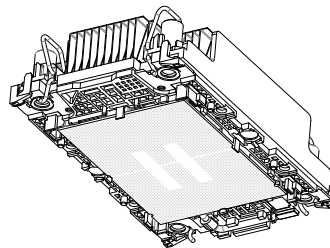

1U Heatsink

Creating the Processor Carrier Assembly

The processor carrier assembly contains a 4th Gen Intel Xeon Scalable processor and a processor carrier.

To create the processor carrier assembly, please follow the steps below:

Note: Before installation, be sure to follow the instructions given on pages 1 and 2 of this chapter to properly prepare for installation.

1. Hold the processor with the component side (including the gold contacts) facing down. Locate the small, gold triangle at the corner of the processor and the corresponding hollowed triangle on the processor carrier as shown in the graphics below. Please note that the triangle indicates the pin 1 location.

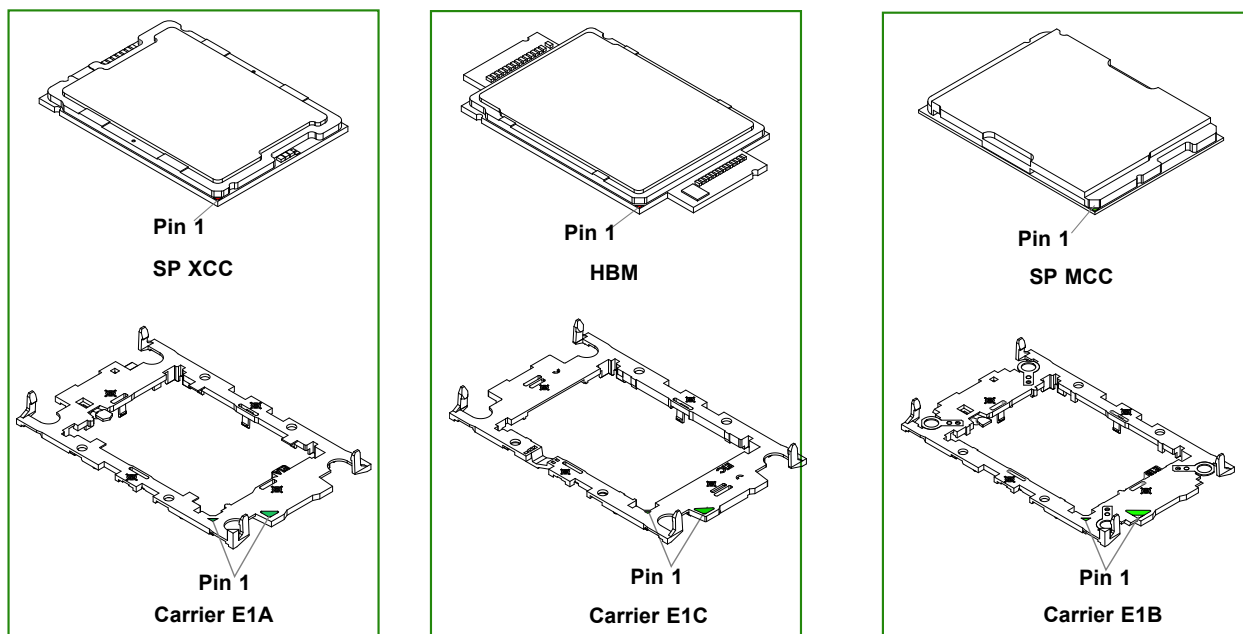

Processor with matching carriers

- Turn over the processor carrier and locate pin 1 on the CPU and pin 1 on the carrier. Then, turn the processor over with component side (including the gold contacts) facing up and locate CPU keys on the processor. Finally, locate the CPU keys and four latches on the carrier as shown below.

SP XCC

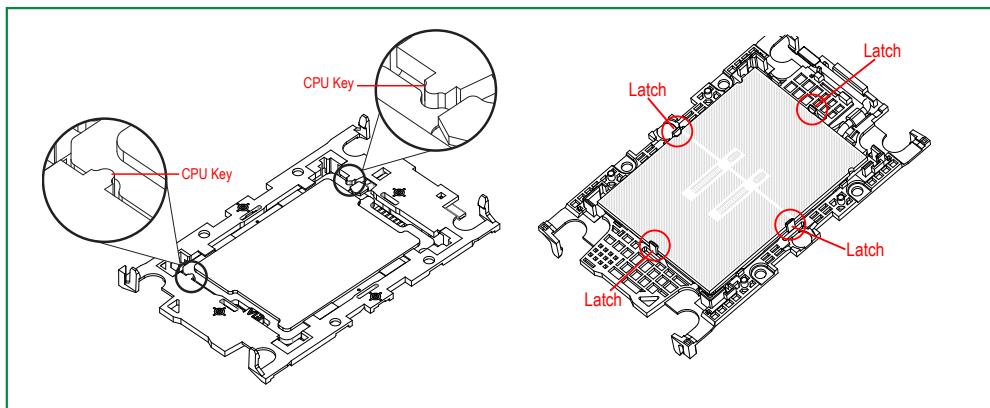

HBM

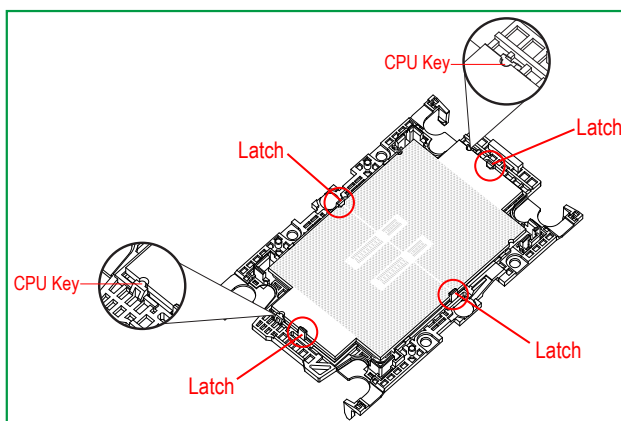

SP MCC

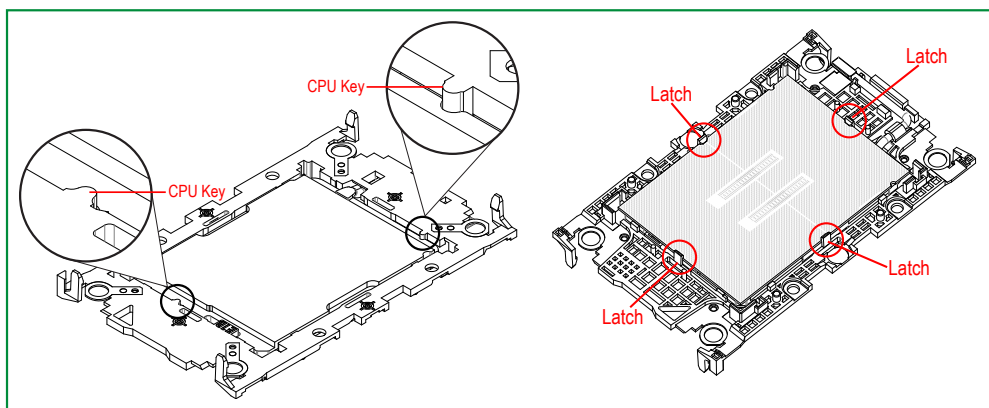

3. Locate the lever on the CPU socket and press it down as shown below.

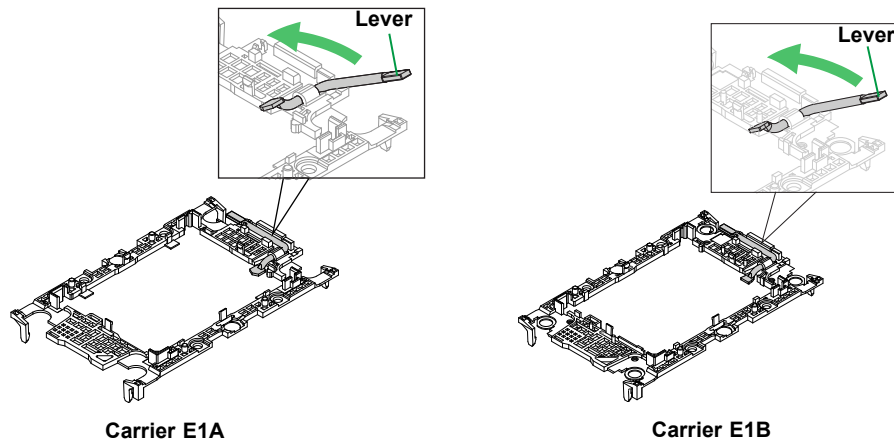

4. Using pin 1 as a guide, carefully align the CPU keys (A and B) on the processor against the CPU keys on the carrier (a and b) as shown in the drawing below.
5. Once they are properly aligned, carefully insert the CPU into the carrier, making sure that the CPU is properly secured by latches 1, 2, 3, and 4.

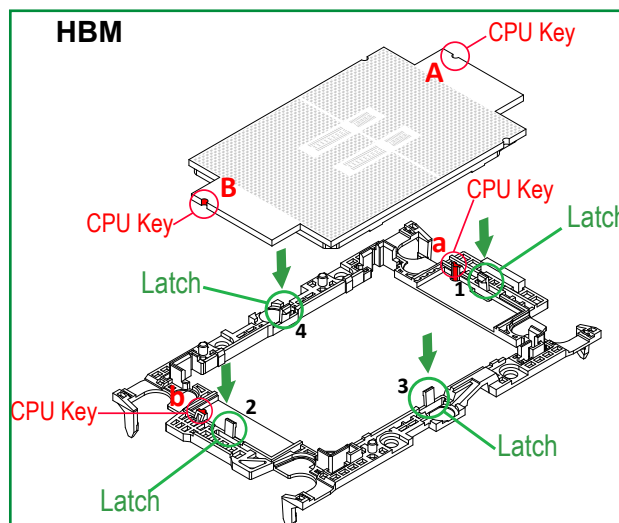
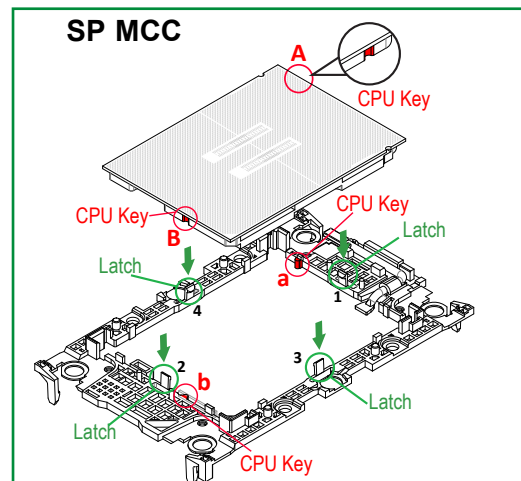
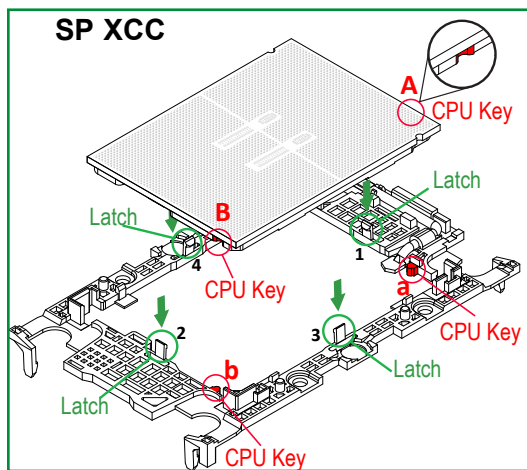

6. After the processor is placed inside the carrier, examine the four sides of the processor, making sure that the processor is properly seated on the carrier.

CPU Carrier Assembly

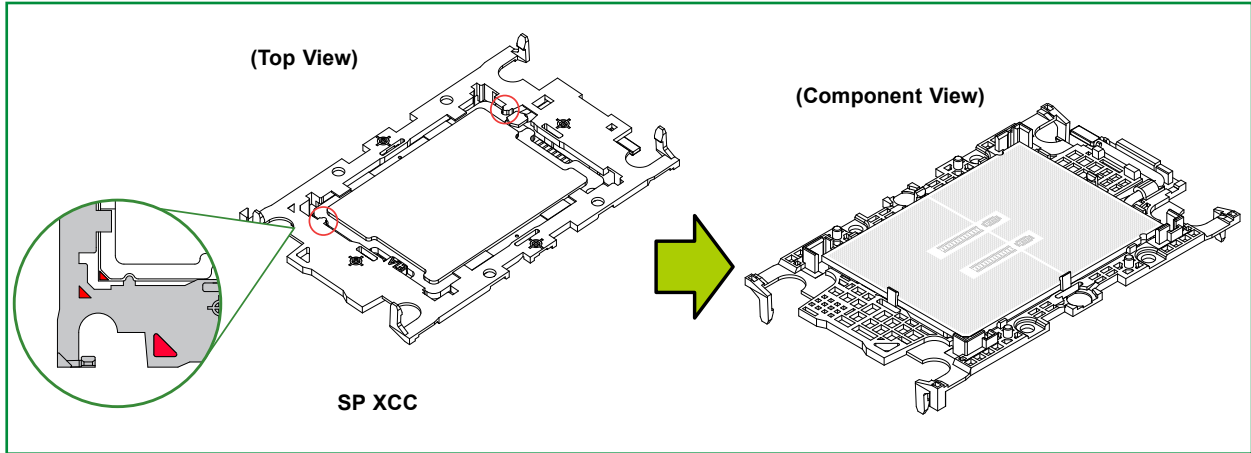

CPU Carrier Assembly

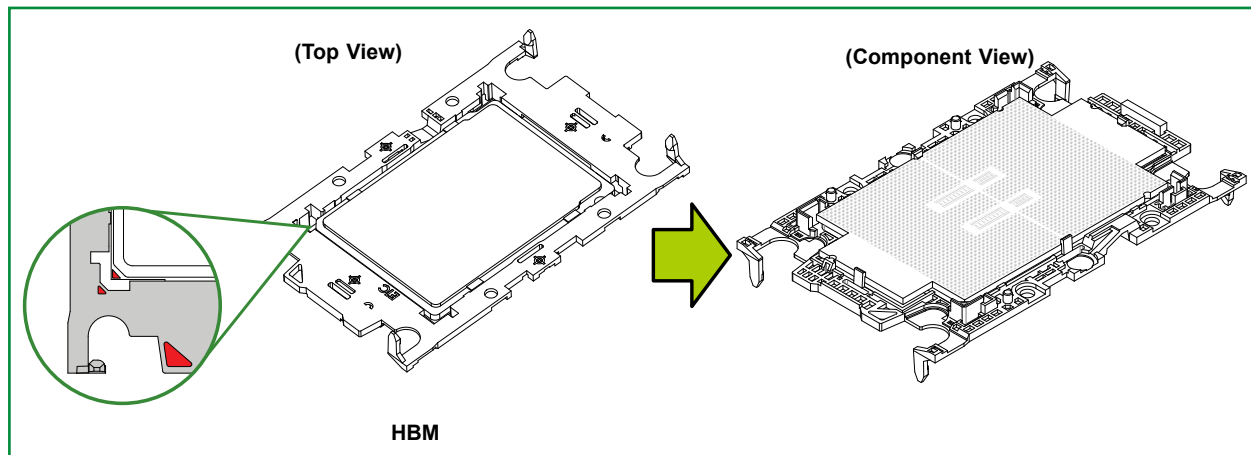

CPU Carrier Assembly

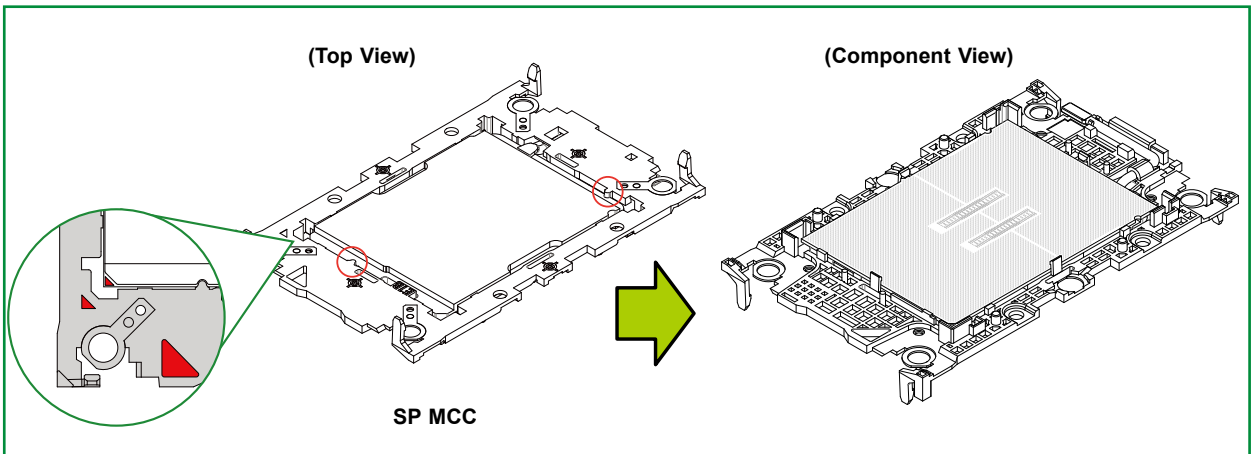

Creating the Processor Heatsink Module (PHM)

After creating the processor carrier assembly, please follow the instructions below to mount the processor carrier into the heatsink to form the processor heatsink module (PHM):

Note: If this is a new heatsink, the thermal grease has been pre-applied on the underside. Otherwise, apply the proper amount of thermal grease.

1. Turn the heatsink over with the thermal grease, which is on the reverse side of the heatsink, facing up. Pay attention to the two triangle cutouts (A, B) located at the diagonal corners of the heatsink as shown in the drawing below.
2. Hold the processor carrier component side facing up, and locate the triangle on the CPU and the triangle on the carrier. (Triangle indicates Pin 1.)
3. Using Pin 1 as a guide, turn the processor carrier assembly over with the gold contacts facing up. Locate Pin 1 (A) on the processor and Pin 1 (a) on the processor carrier assembly.
4. Align the corner marked a on the processor carrier assembly against the triangle cutout A on the heatsink, and align the corners marked b, c, and d on the processor assembly against the corners marked B, C, and D on the heatsinks.
5. Once they are properly aligned, place the corners marked a, b, c, and d on the processor carrier assembly into the corners of the heatsink marked A, B, C, and D making sure that all plastic clips are properly attached to the heatsink.

CPU Carrier Assembly (CPU Component Side & Heatsink Bottom Side)

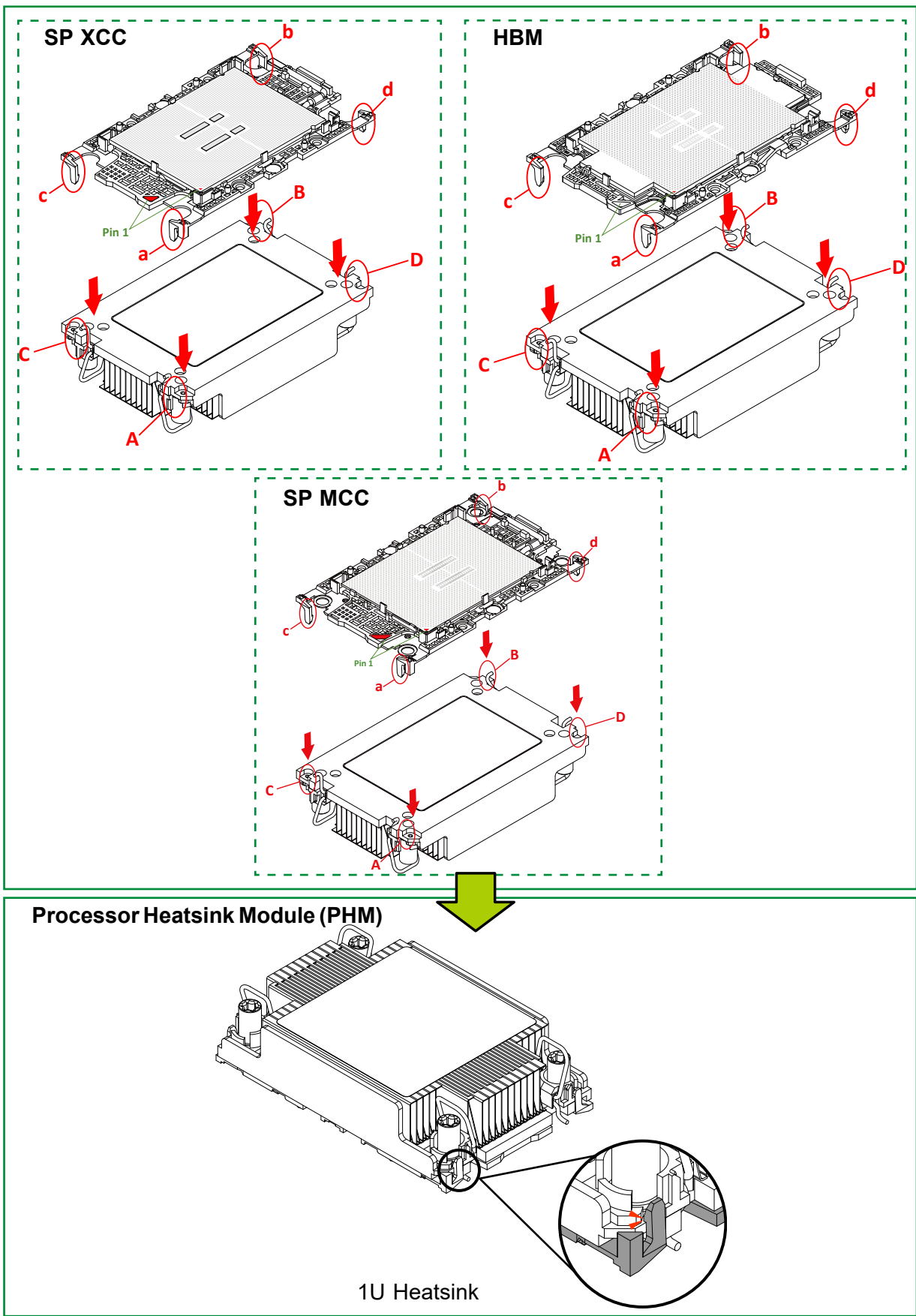

Preparing the CPU Socket for Installation

This motherboard comes with a plastic protective cover installed on the CPU socket. Remove it from the socket to install the Processor Heatsink Module (PHM). Gently pull up one corner of the plastic protective cover to remove it.

1. Press the tabs inward.

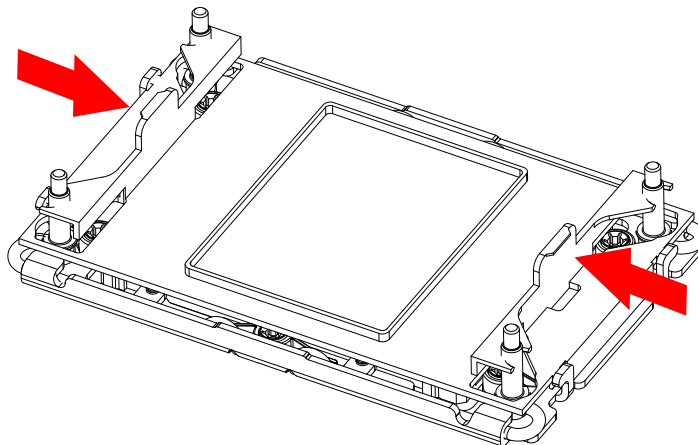

2. Pull up the protective cover from the socket.

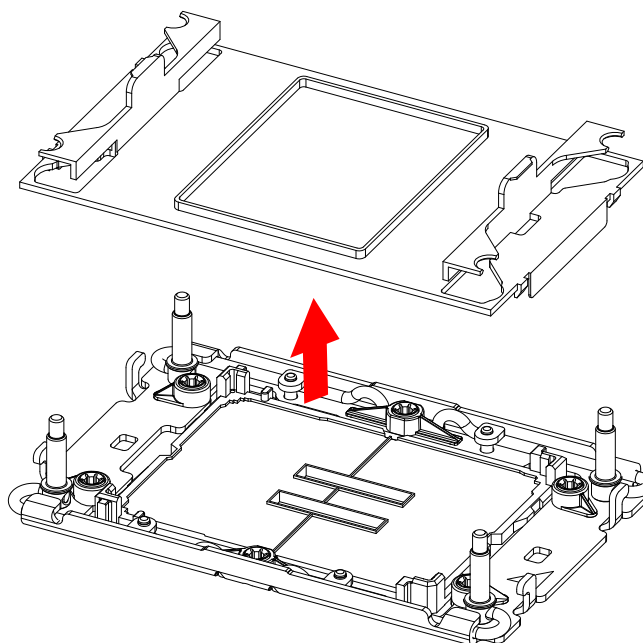

Preparing to Install the PHM into the CPU Socket

After assembling the Processor Heatsink Module, you are ready to install it into the CPU socket. To ensure the proper installation, please follow the procedures below:

1. Locate four threaded fasteners (a, b, c, d) on the CPU socket.

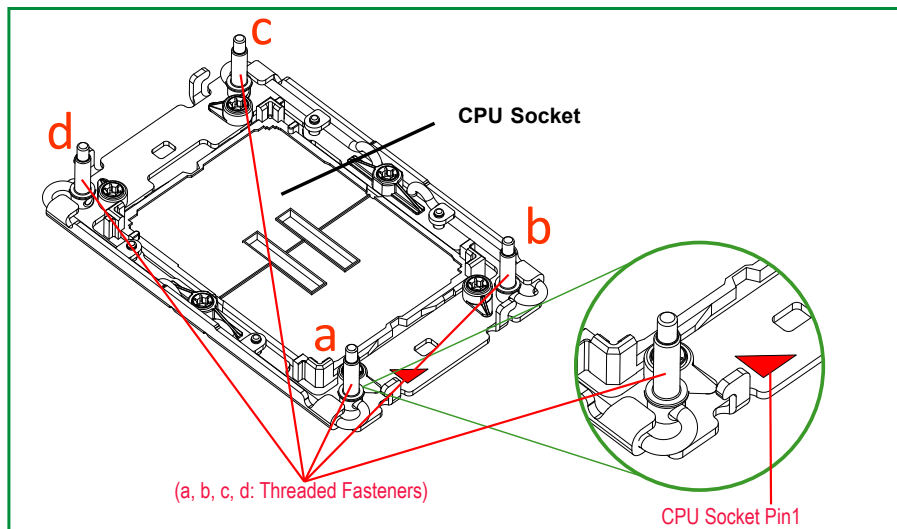

2. Locate four PEEK nuts (A, B, C, D) and four rotating wires (1, 2, 3, 4) on the heatsink as shown in the graphics below.

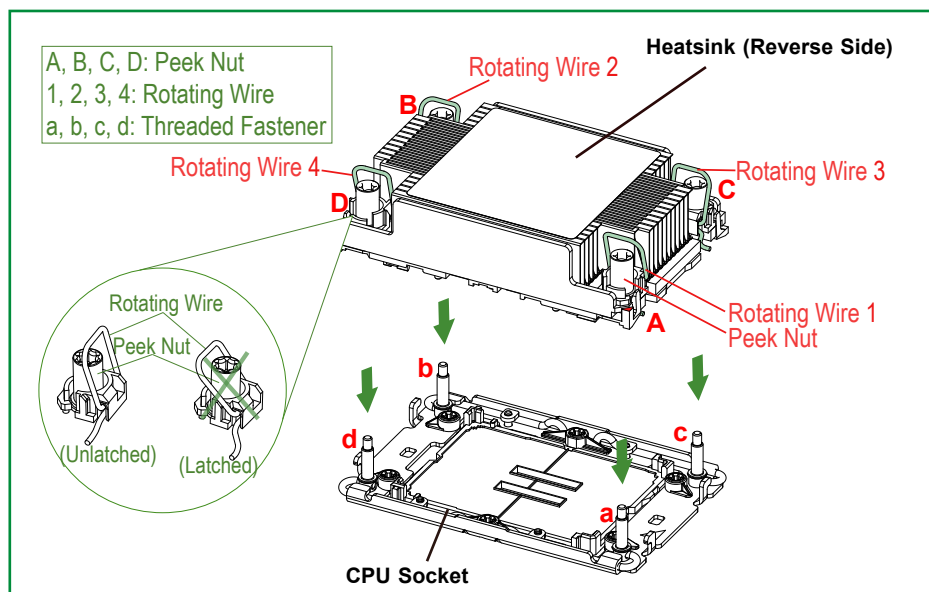

1U Heatsink

3. Check the rotating wires (1, 2, 3, 4) to make sure that they are at unlatched positions as shown in the drawing below before installing the PHM into the CPU socket.

1U Heatsink

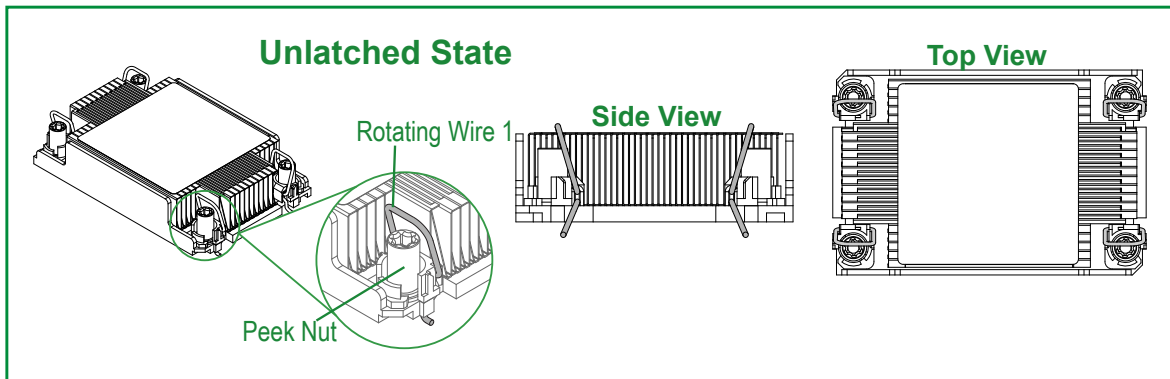

4. With a T30 screwdriver, tighten all PEEK nuts in the sequence of A, B, C, and D with even pressure. To avoid damaging the processor or socket, do not use excessive force when tightening the PEEK nuts. (For best durability, 8in-lbf torque is recommended.)
5. Examine all corners of the heatsink to ensure that the PHM is firmly attached to the CPU socket.

Installing the PHM into the CPU Socket

1. Align PEEK nut A, which is next to the triangle (Pin 1) on the heatsink, against threaded fastener a on the CPU socket. Then align PEEK nuts B, C, and D on the heatsink against threaded fasteners b, c, and d on the CPU socket, making sure that all PEEK nuts on the heatsink are properly aligned with the correspondent threaded fasteners on the CPU socket.
2. Once they are aligned, gently place the heatsink on top the CPU socket, making sure that each PEEK nut is properly attached to its corresponding threaded fastener.

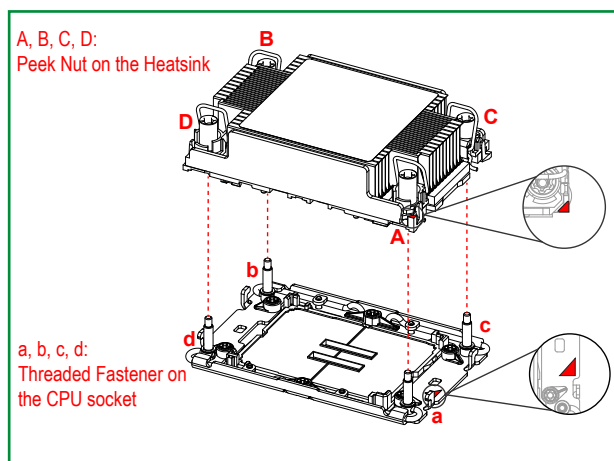

1U Heatsink

3. Press all four rotating wires outwards and make sure that the heatsink is securely latched onto the CPU socket.

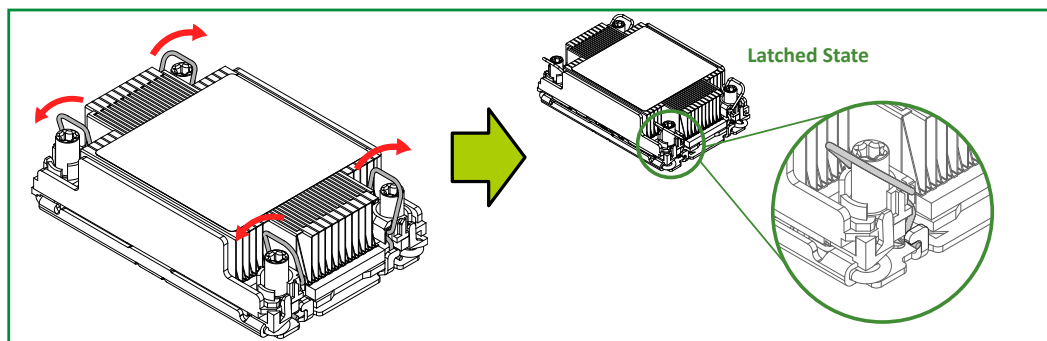

1U Heatsink

4. With a T30 screwdriver, tighten all PEEK nuts in the sequence of A, B, C, and D with even pressure. To avoid damaging the processor or socket, do not use excessive force when tightening the PEEK nuts. (For best durability, 8in-lbf torque is recommended.)
5. Examine all corners of the heatsink to ensure that the PHM is firmly attached to the CPU socket.

Note: Use a T-30 torque driver. 8 in-lb is recommended; but torques in the 6~12 in-lb range are supported, with a minimum durability of 30 installation/removal cycles at 8 in-lb and 12 cycles at 12 in-lb.

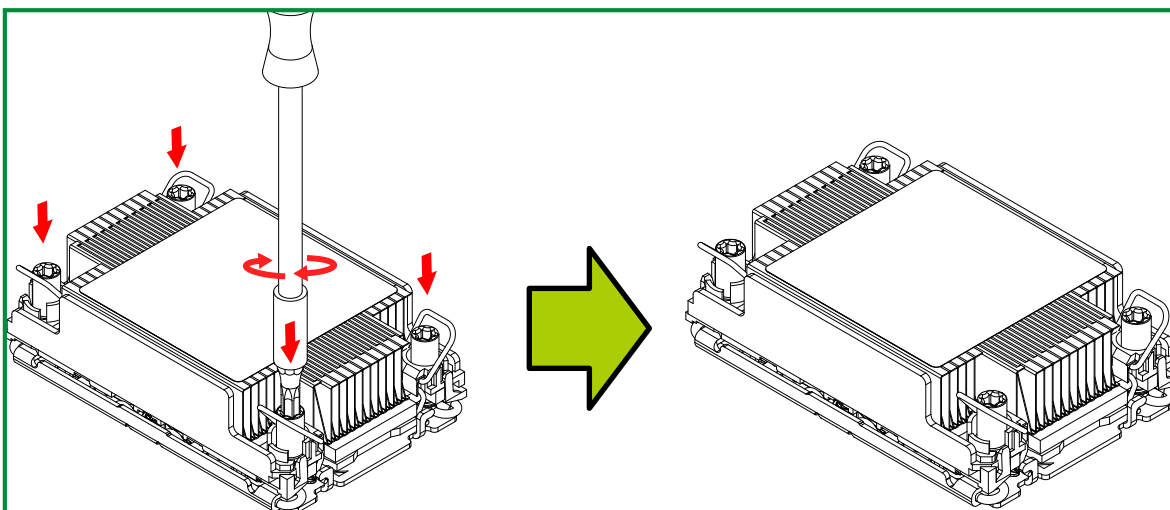

1U Heatsink

Removing the PHM from the CPU Socket

Before removing the processor heatsink module (PHM) from the motherboard, shut down the system and then unplug the AC power cord from all power supplies. Then follow the steps below:

1. Use a T30 screwdriver to loosen the four PEEK nuts on the heatsink in the sequence of A, B, C, and D.

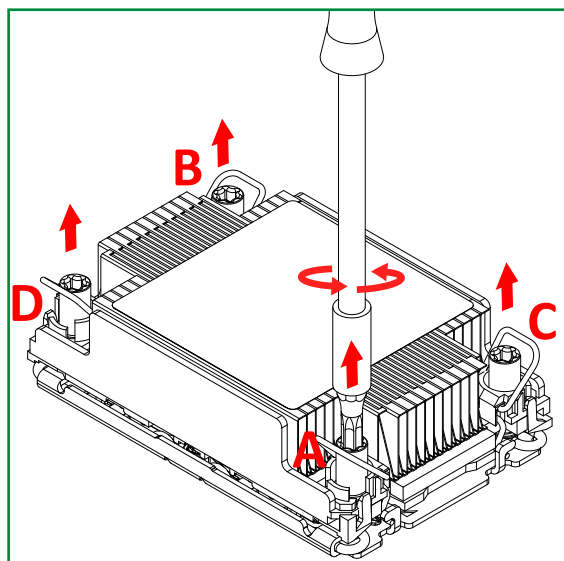

1U Heatsink

2. Once the PEEK nuts are loosened from the CPU socket, press the rotating wires inwards to unlatch the PHM from the socket as shown in the drawings below.

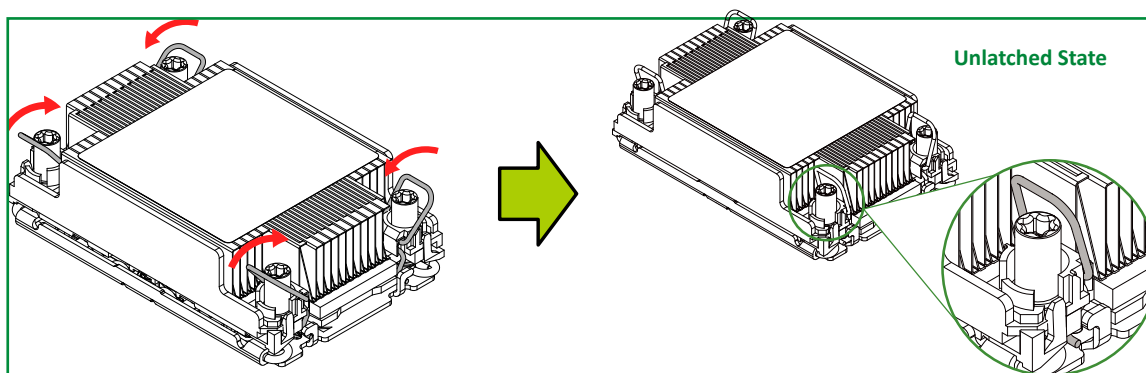

1U Heatsink

3. Gently pull the PHM upwards to remove it from the CPU socket.

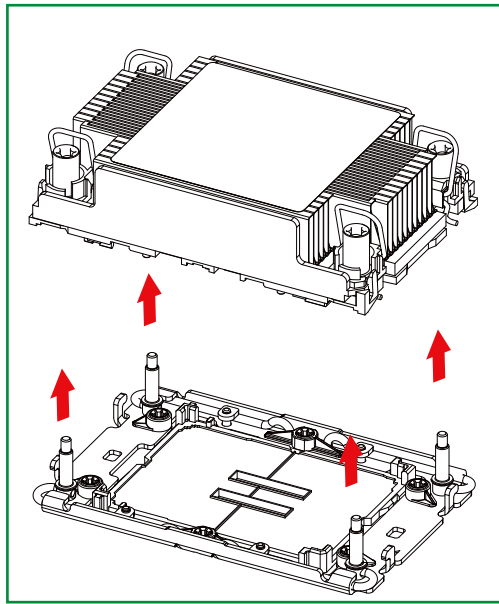

1U Heatsink

Removing the Processor Carrier Assembly from the PHM

To remove the processor carrier assembly from the PHM, please follow the steps below:

1. Detach the four plastic clips (marked a, b, c, d) on the processor carrier assembly from the four corners of the heatsink (marked A, B, C, D) as shown in the drawings below.

1U Heatsink (View of Component Side & Heatsink Bottom Side)

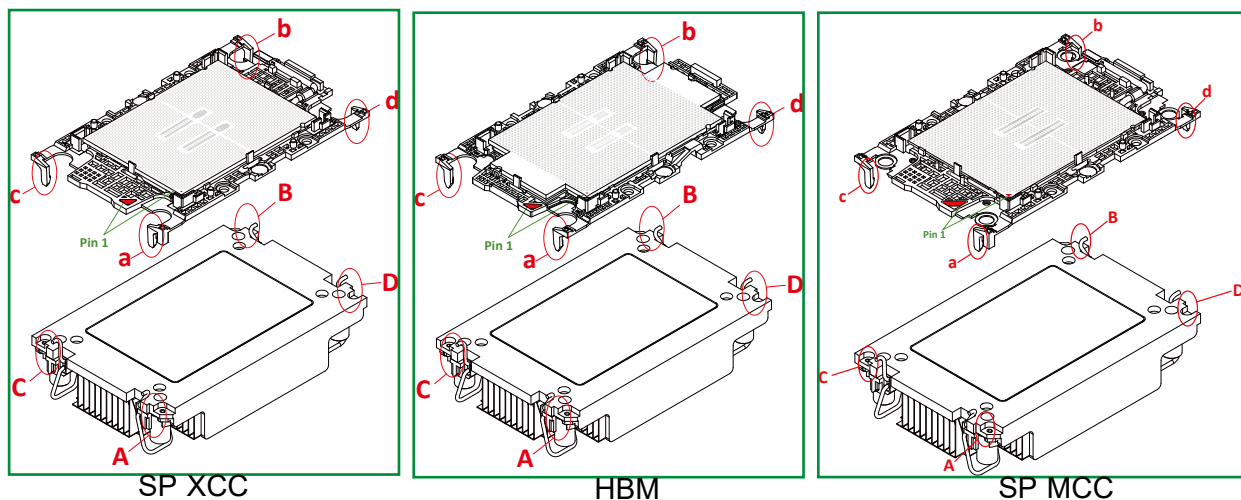

2. When all plastic clips are detached from the heatsink, remove the processor carrier assembly from the heatsink.

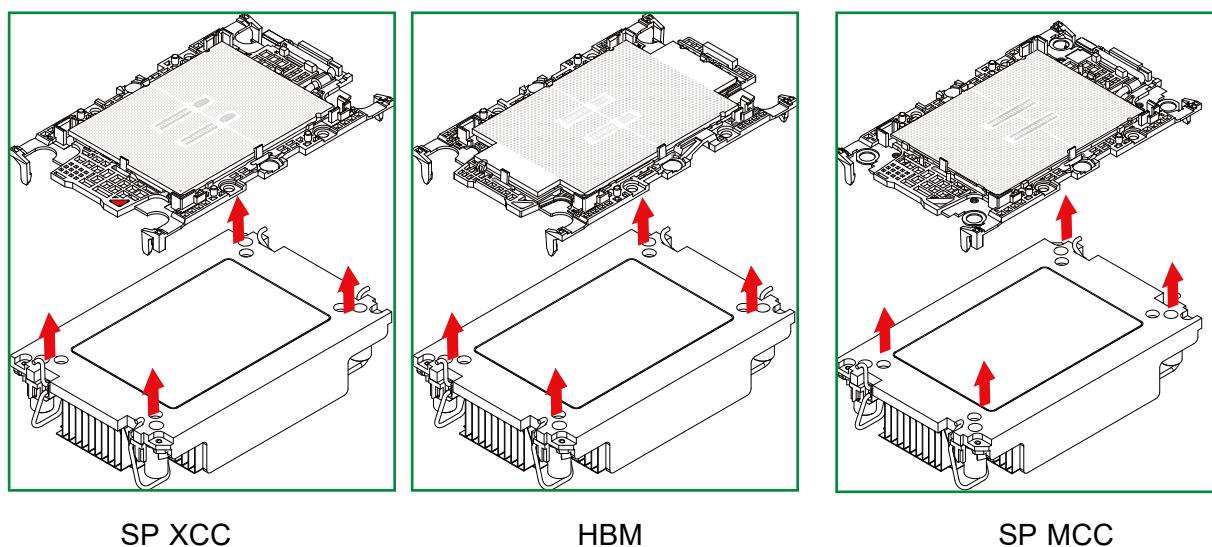

Note: If it is difficult to remove the processor carrier assembly from the PHM, you may use the lever to break the TIM (Thermal Interface Material) - as seen in the next section "[Removing the Processor from the Processor Carrier Assembly.](#)"

Removing the Processor from the Processor Carrier Assembly

Once you have removed the processor carrier assembly from the PHM, you are ready to remove the processor from the processor carrier by following the steps below.

1. Unlock the lever from its locked position and push the lever upwards to disengage the processor from the processor carrier as shown in the drawing on the right below.

CPU Carrier Assembly (carrier E1A)

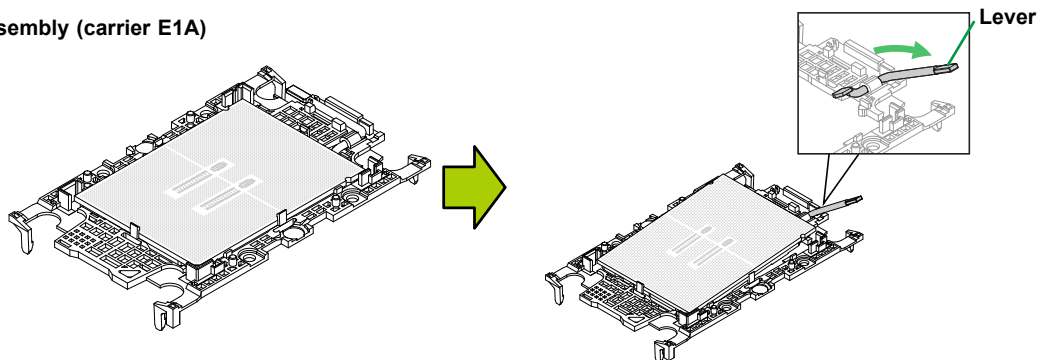

CPU Carrier Assembly (carrier E1B)

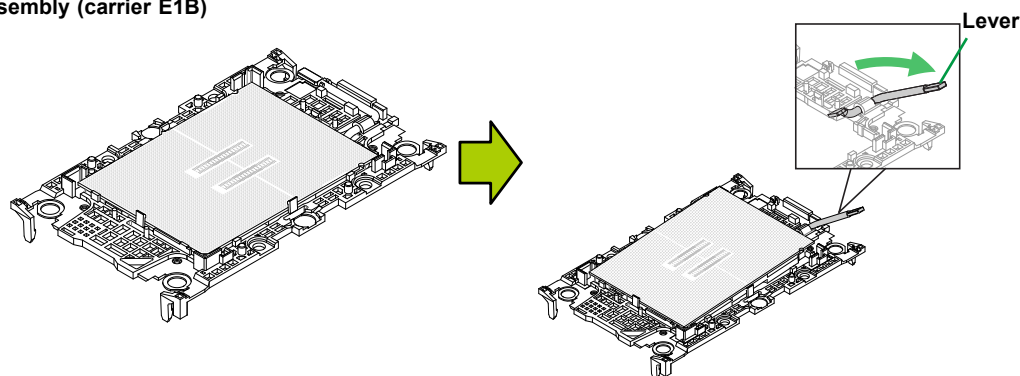

2. Once the processor is loosened from the carrier, carefully remove the processor from the processor carrier.

Note: Please handle the processor with care to avoid damaging the processor and its pins.

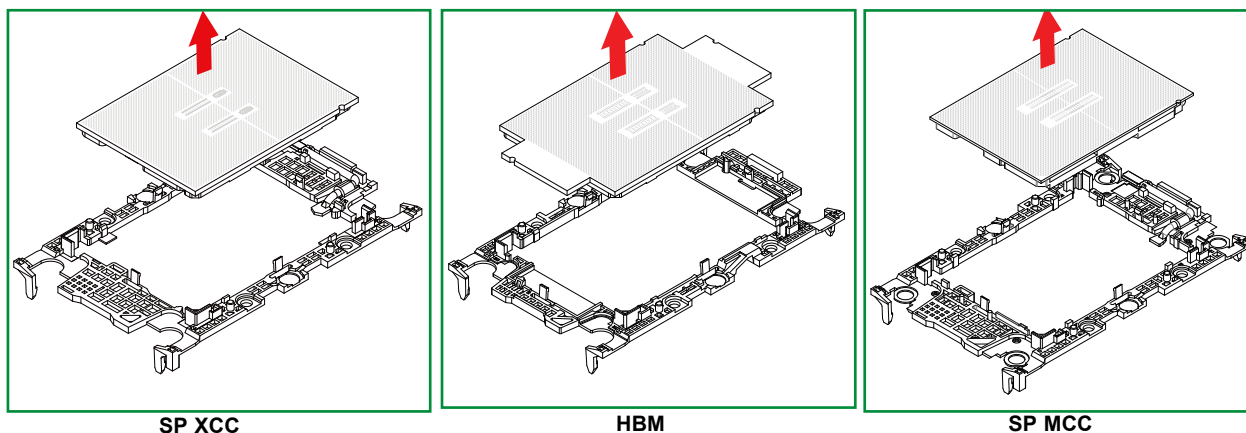

SP XCC

HBM

SP MCC

3.5 Motherboard Installation

All motherboards have standard mounting holes to fit different types of chassis. Make sure that the locations of all the mounting holes for both the motherboard and the chassis match. Although a chassis may have both plastic and metal mounting fasteners, metal ones are highly recommended because they ground the motherboard to the chassis. Make sure that the metal standoffs click in or are screwed in tightly.

Tools Needed



Phillips Screwdriver (1)



Phillips Screws (9)



Standoffs (9) (Only if Needed)

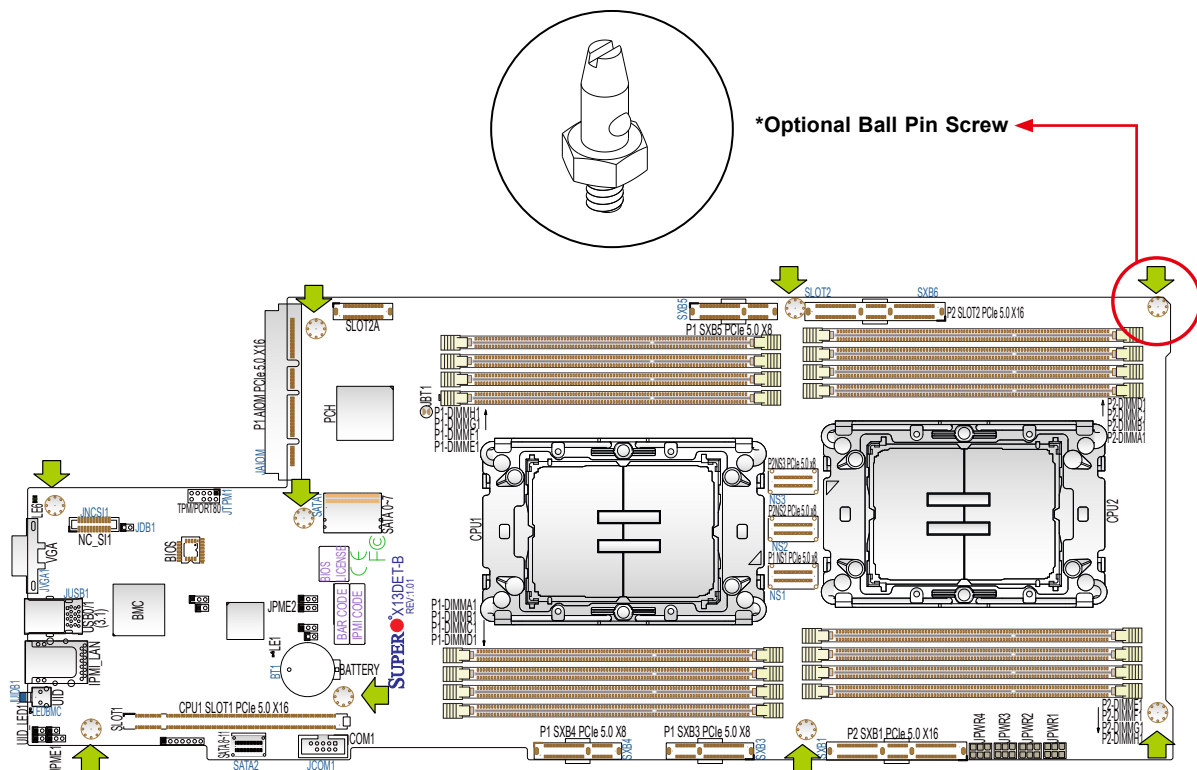

Location of Mounting Holes

Note 1: To avoid damaging the motherboard and its components, please do not use a force greater than 8 lbf-in on each mounting screw during motherboard installation.

Note 2: Some components are very close to the mounting holes. Please take precautionary measures to avoid damaging these components when installing the motherboard to the chassis.

Note 3: If installing an M.2 long riser, instead of the standard Phillips Screw, there will need to be a Ball Pin Screw installed at the location specified on the motherboard layout.

Installing the Motherboard

1. Install the I/O shield into the back of the chassis, if applicable.
2. Locate the mounting holes on the motherboard. See the previous page for the location.

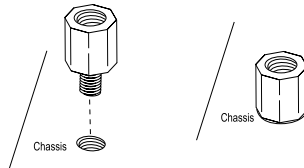

3. Locate the matching mounting holes on the chassis. Align the mounting holes on the motherboard against the mounting holes on the chassis.

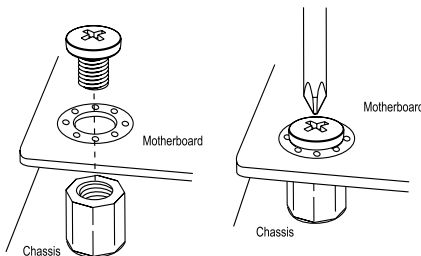

4. Install standoffs in the chassis as needed.
5. Install the motherboard into the chassis carefully to avoid damaging other motherboard components.
6. Using the Phillips screwdriver, insert a pan head #6 screw into a mounting hole on the motherboard and its matching mounting hole on the chassis.
7. Repeat Step 5 to insert #6 screws into all mounting holes.
8. Make sure that the motherboard is securely placed in the chassis.

Note: Images displayed are for illustration only. Your chassis or components might look different from those shown in this manual.

3.6 Memory Support and Installation

Note: Check the Supermicro website for recommended memory modules.

Important: Exercise extreme care when installing or removing memory modules to prevent any possible damage.

Memory Support

This X13DET-B motherboard supports up to 4TB RDIMM DDR5 (288-pin) ECC memory with speeds up to 4800MT/s in 16 DIMM slots.

DDR5 Memory Support for 4th Gen Intel Xeon Scalable Processors

For your system memory to work properly, please follow the memory population tables below to install the memory modules on your motherboard. These memory population tables were created based on the general memory population guidelines provided by Intel to support Supermicro X13DP motherboards.

DDR5 Memory Support for the 4th Gen Intel Xeon Scalable Processors			
Type	Ranks Per DIMM & Data Width (Stack)	DIMM Capacity (GB)	1DPC (Note)
			16GB
RDIMM	SRx8 (RC D)	16GB	4800
	SRx4 (RC C)	32GB	
	SRx4 (RC F) 9x4	32GB	
	DRx8 (RC E)	32GB	
	DRx4 (RC A)	64GB	
	DRx4 (RC B) 9x4	64GB	
RDIMM 3DS	(4R/8R) x4 (RC A)	2H-128GB 4H-256GB	
LRDIMM/LRDIMM-3DS	N/A	N/A	Not Supported

Note: 1DPC (1 DIMM per Channel) applies to 1 SPC (Socket Per Channel) or 2 SPC (Sockets Per Channel) implementation.

Memory Population Table for the 4th Gen Intel Xeon Scalable Processors

DDR5 Memory Population Table for X13DP Motherboards (with 16 DIMMs installed)	
1 CPU:	Memory Population Sequence
1 CPU & 1 DIMM	P1-DIMMA1 P1-DIMME1 P1-DIMMB1 P1-DIMMF1
1 CPU & 2 DIMMs	P1-DIMMA1 / P1-DIMMG1 P1-DIMMC1 / P1-DIMME1
1 CPU & 4 DIMMs	P1-DIMMA1 / P1-DIMMC1 / P1-DIMME1 / P1-DIMMG1
1 CPU & 6 DIMM	P1-DIMMA1 / P1-DIMMC1 / P1-DIMMD1 / P1-DIMME1 / P1-DIMMF1 / P1-DIMMG1 P1-DIMMA1 / P1-DIMMB1 / P1-DIMMC1 / P1-DIMME1 / P1-DIMMG1 / P1-DIMMH1 P1-DIMMB1 / P1-DIMMC1 / P1-DIMMD1 / P1-DIMME1 / P1-DIMMF1 / P1-DIMMH1 P1-DIMMA1 / P1-DIMMB1 / P1-DIMMD1 / P1-DIMMF1 / P1-DIMMG1 / P1-DIMMH1
1 CPU & 8 DIMMs	P1-DIMMA1 / P1-DIMMB1 / P1-DIMMC1 / P1-DIMMD1 / P1-DIMME1 / P1-DIMMF1 / P1-DIMMG1 / P1-DIMMH1
2 CPUs: (Recommended)	Memory Population Sequence
2 CPUs & 2 DIMMs	CPU1: P1-DIMMA1, CPU2: P2-DIMMA1 CPU1: P1-DIMME1, CPU2: P2-DIMME1 CPU1: P1-DIMMB1, CPU2: P2-DIMMB1 CPU1: P1-DIMMF1, CPU2: P2-DIMMF1
2 CPUs & 4 DIMMs	CPU1: P1-DIMMA1 / P1-DIMMG1, CPU2: P2-DIMMA1 / P2-DIMMG1 CPU1: P1-DIMMC1 / P1-DIMME1, CPU2: P2-DIMMC1 / P2-DIMME1
2 CPUs & 8 DIMMs	CPU1: P1-DIMMA1 / P1-DIMMC1 / P1-DIMME1 / P1-DIMMG1 CPU2: P2-DIMMA1 / P2-DIMMC1 / P2-DIMME1 / P2-DIMMG1
2 CPUs & 12 DIMMs	CPU1: P1-DIMMA1/P1-DIMMC1/P1-DIMMD1/P1-DIMME1/P1-DIMMF1/P1-DIMMG1 CPU2: P2-DIMMA1/P2-DIMMC1/P2-DIMMD1/P2-DIMME1/P2-DIMMF1/P2-DIMMG1 CPU1: P1-DIMMA1/P1-DIMMB1/P1-DIMMC1/P1-DIMME1/P1-DIMMG1/P1-DIMMH1 CPU2: P2-DIMMA1/P2-DIMMB1/P2-DIMMC1/P2-DIMME1/P2-DIMMG1/P2-DIMMH1 CPU1: P1-DIMMB1/P1-DIMMC1/P1-DIMMD1/P1-DIMME1/P1-DIMMF1/P1-DIMMH1 CPU2: P2-DIMMB1/P2-DIMMC1/P2-DIMMD1/P2-DIMME1/P2-DIMMF1/P2-DIMMH1 CPU1: P1-DIMMA1/P1-DIMMB1/P1-DIMMD1/P1-DIMMF1/P1-DIMMG1/P1-DIMMH1 CPU2: P2-DIMMA1/P2-DIMMB1/P2-DIMMD1/P2-DIMMF1/P2-DIMMG1/P2-DIMMH1
2 CPUs & 16 DIMMs	CPU1: P1-DIMMA1/P1-DIMMB1/P1-DIMMC1/P1-DIMMD1/P1-DIMME1/P1-DIMMF1/P1-DIMMG1/P1-DIMMH1 CPU2: P2-DIMMA1/P2-DIMMB1/P2-DIMMC1/P2-DIMMD1/P2-DIMME1/P2-DIMMF1/P2-DIMMG1/P2-DIMMH1

Note: This memory configuration is recommended by Supermicro for optimal memory performance. Please use this configuration to maximize your memory performance.

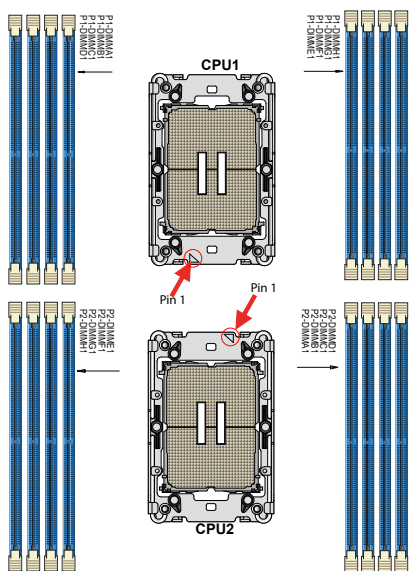

Note: The drawing above shows DIMM module population for each CPU installed on the motherboard. Please install your processors starting with CPU Socket 1.

DIMM Installation

1. Insert the desired number of DIMMs into the memory slots based on the recommended DIMM population tables in the previous section. Locate DIMM memory slots on the motherboard as shown on the right.
2. Push the release tabs outwards on both ends of the DIMM slot to unlock it.

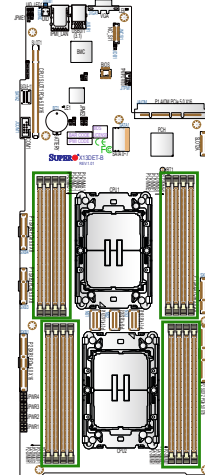
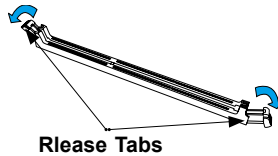

3. Align the key of the memory module with the receptive point on the memory slot.

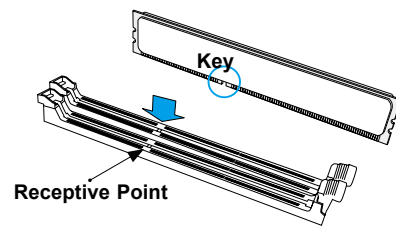

4. Align the notches on both ends of the module against the receptive points on the ends of the slot.

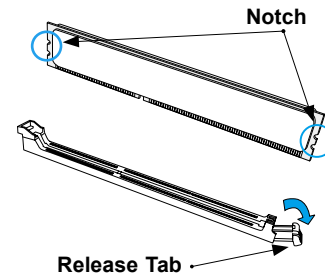

5. Push both ends of the module straight down into the slot until the module snaps into place.
6. Press the release tabs to the lock positions to secure the memory module into the slot.

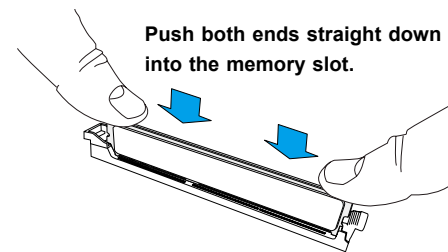

DIMM Removal

Press both release tabs on the ends of the memory module to unlock it. Once the memory module has been loosened, remove it from the memory slot.

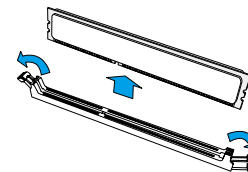

Important: Please do not use excessive force when pressing the release tabs on the ends of the DIMM socket to avoid causing any damage to the memory module or the DIMM socket. Please handle memory modules with care. Carefully follow all the instructions given on page 1 of this chapter to avoid ESD-related damages done to your memory modules or components.

3.7 Motherboard Battery

The motherboard uses non-volatile memory to retain system information when system power is removed. This memory is powered by a lithium battery residing on the motherboard.

Replacing the Battery

To install an onboard battery, follow the steps below:

1. Power off your system and unplug your power cable.
2. Locate the onboard battery as shown below
3. Identify the battery's polarity. The positive (+) side should be facing up.
4. Insert the battery into the battery holder and push it down until you hear a click to ensure that the battery is securely locked.

Note: Handle used batteries carefully. Do not damage the battery in any way; a damaged battery may release hazardous materials into the environment. Do not discard a used battery in the garbage or a public landfill. Please comply with the regulations set up by your local hazardous waste management agency to dispose of your used battery properly.

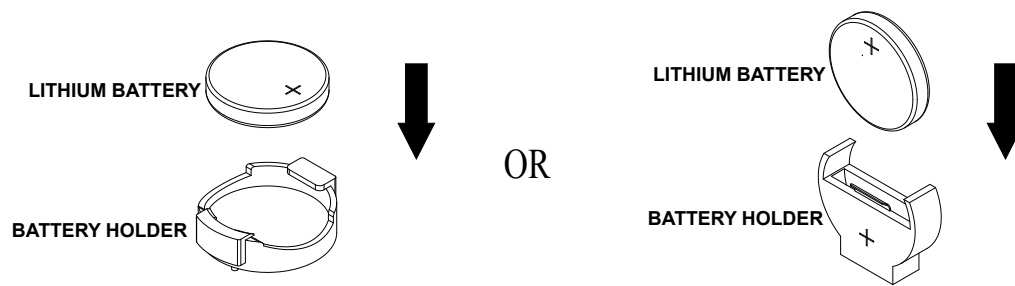

Figure 3-3. Installing the Onboard Battery

Important: There is a danger of explosion if the onboard battery is installed upside down (which reverses its polarities). This battery must be replaced only with the same or an equivalent type recommended by the manufacturer (BR2032).

3.8 Storage Drives

The CSE-827BQ2-R3K04P chassis supports 12 hot-swap 3.5" storage drives (HDDs or SSDs). Each node controls three drives.

- HNTR: 12 hybrid SATA3/NVMe drives total
- HNC8R: 12 hybrid SAS3/NVMe drives (SAS3 supported via Broadcom 3808) total

Drive Carriers

Each drive carrier has two LED indicators: an activity indicator and a status indicator. For RAID configurations using a controller, the meaning of the status indicator is described in the table below. For OS RAID or non-RAID configurations, some LED indications are not supported, such as hot spare. For VROC configurations, refer to the VROC appendix in this manual.

Drive Carrier LED Indicator			
	Color	Blinking Pattern	Behavior for Device
Activity LED	Blue	Solid On	SAS/NVMe drive installed
	Blue	Blinking	I/O activity
	Off		Idle SATA or no drive
Status LED	Red	Solid On	Failure of drive with RSTe support
	Red	Blinking at 1 Hz	Rebuild drive with RSTe support
	Red	Blinking with two blinks and one stop at 1 Hz	Hot spare for drive with RSTe support (not supported in VMD mode)
	Red	On for five seconds, then off	Power on for drive with RSTe support
	Red	Blinking at 4 Hz	Identify drive with RSTe support
	Green	Solid On	Safe to remove NVMe device (not supported in VMD mode)
	Amber	Blinking at 1 Hz	Attention state---do not remove NVMe device (not supported in VMD mode)
	Off		Idle SATA or no drive

Note: Enterprise level hard disk drives are recommended for use in Supermicro chassis and servers. For information on recommended HDDs, see the Supermicro website, <http://www.supermicro.com/products/nfo/files/storage/SBB-HDDCompList.pdf>.

Drive Configuration

The CSE-827BQ2-R3K04P chassis contains four separate computing node drawers, each with its own motherboard. Each node controls a set of three drives. If a node drawer is pulled out of the chassis, the drives associated with that node will power down.

Node Drawer Locations	
Node A controls drives A1, A2, and A3	Node B controls drives B1, B2, and B3
Node C controls drives C1, C2, and C3	Node D controls drives D1, D2, and D3

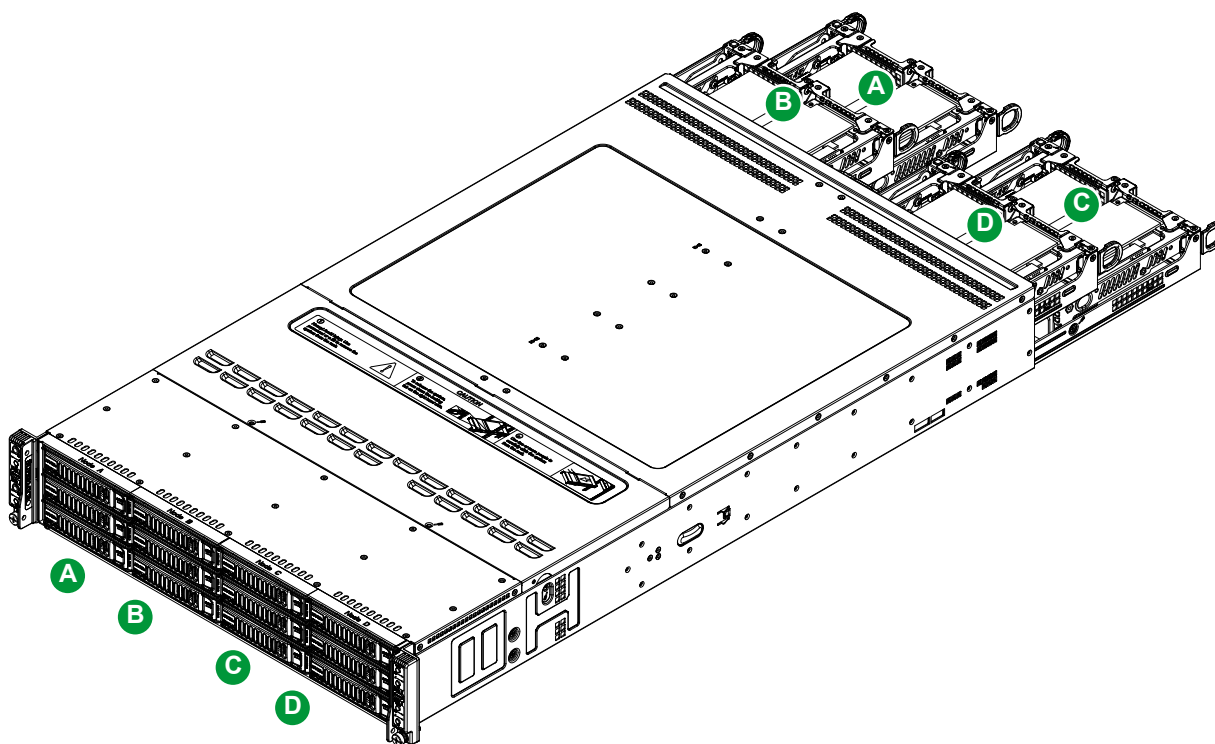

Figure 3-4. Storage Drives and the Corresponding Nodes

Installing Drives

Removing Drive Carriers from the Chassis

1. Press the release button on the drive carrier. This extends the drive carrier handle.
2. Use the handle to pull the carrier out of the chassis.
3. Remove the dummy drive from the carrier.

Important: Except for short periods of time (swapping drives), do not operate the server with the drive carriers removed from the bays, regardless of how many drives are installed, for proper airflow.

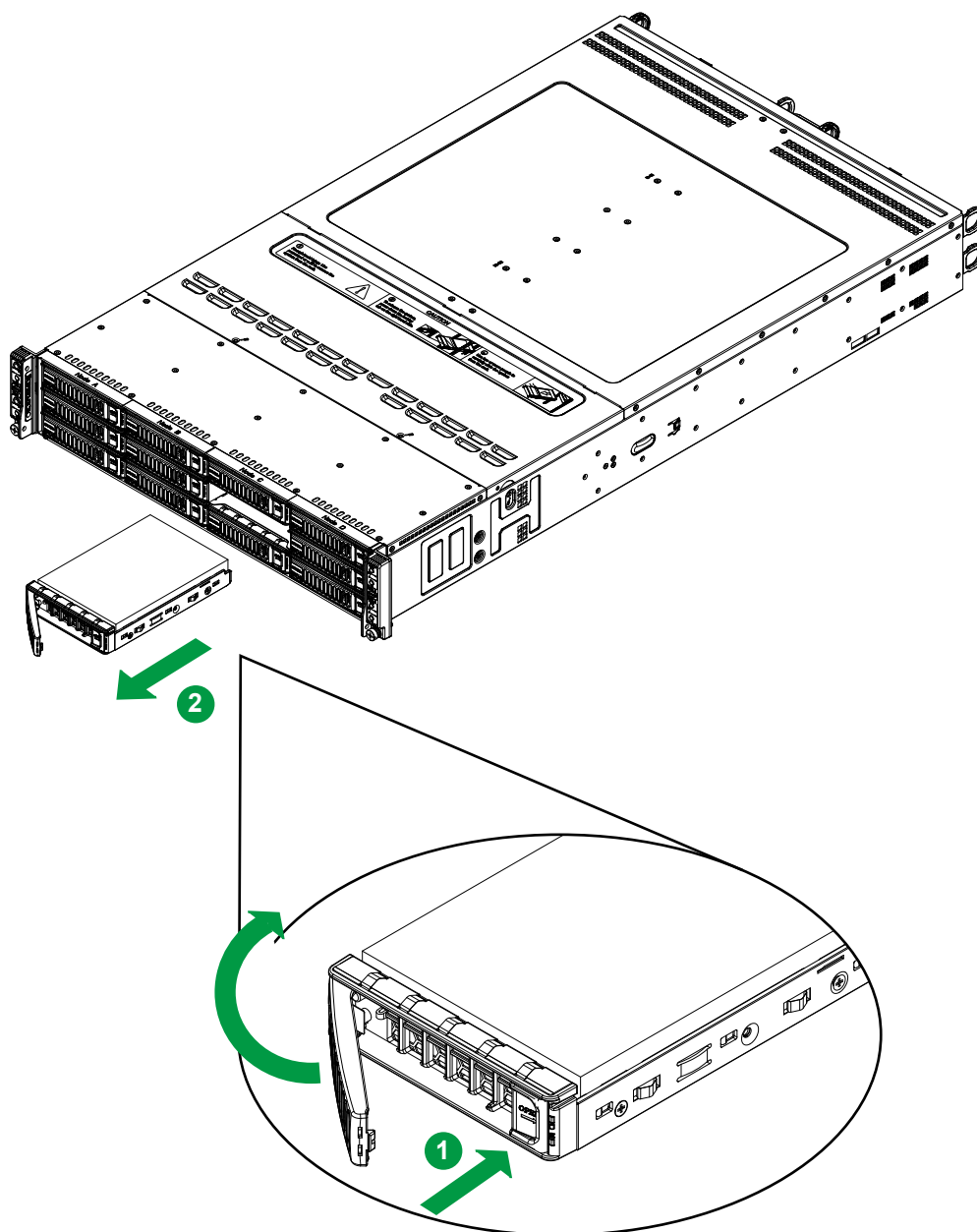

Figure 3-5. Removing a Drive Carrier

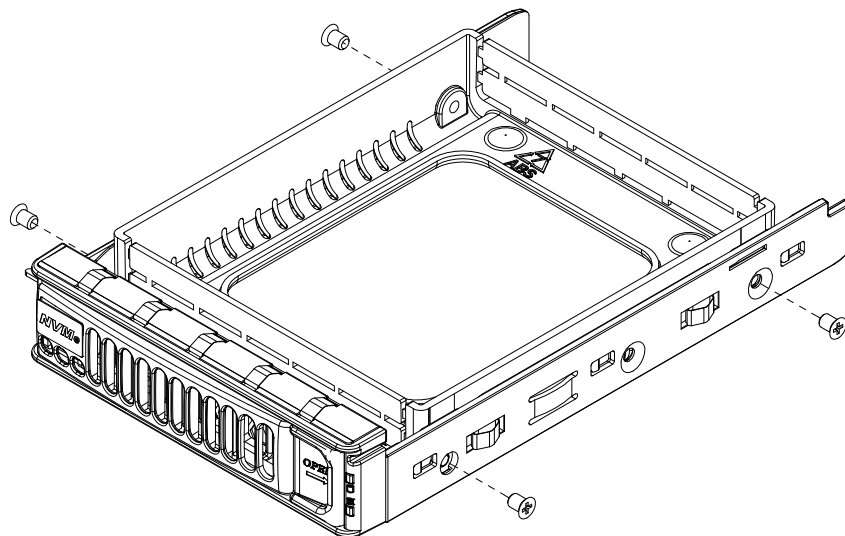

Figure 3-6. Removing a Dummy Drive from the Drive Carrier

Installing a Drive

1. Install a new drive into the carrier with the printed circuit board side facing down so that the mounting holes in the drive align with those in the carrier.
2. Secure the hard drive into the carrier with the screws.

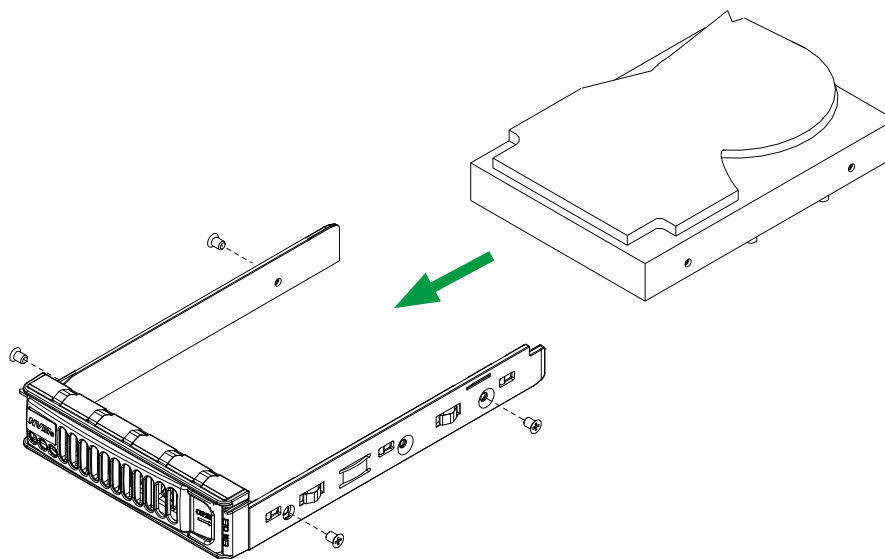

Figure 3-7. Installing the Hard Drive

3. Insert the drive and carrier into its bay with the release button on the right. When the carrier reaches the rear of the bay, the release handle starts to retract.
4. Push the upper part of the drive carrier handle until it clicks into the locked position.

Hot-Swap for NVMe Drives

Supermicro servers support NVMe surprise hot-swap. For even better data security, NVMe *orderly* hot-swap is recommended. NVMe drives can be ejected and replaced remotely using BMC.

Note: If you are using VROC, see the [Hot-Swap Drives](#) section in Chapter 6 instead.

Ejecting a Drive

1. **BMC > System > Storage Monitoring > Physical View**
2. Select Device, Group and Slot, and click **Eject**. After ejecting, the drive Status LED indicator turns green.
3. Remove the drive.

Note that *Device* and *Group* are categorized by the CPLD design architecture. The SYS-621BT-H Series server has one Device and one Group.

Slot is the slot number on which the NVMe drives are mounted.

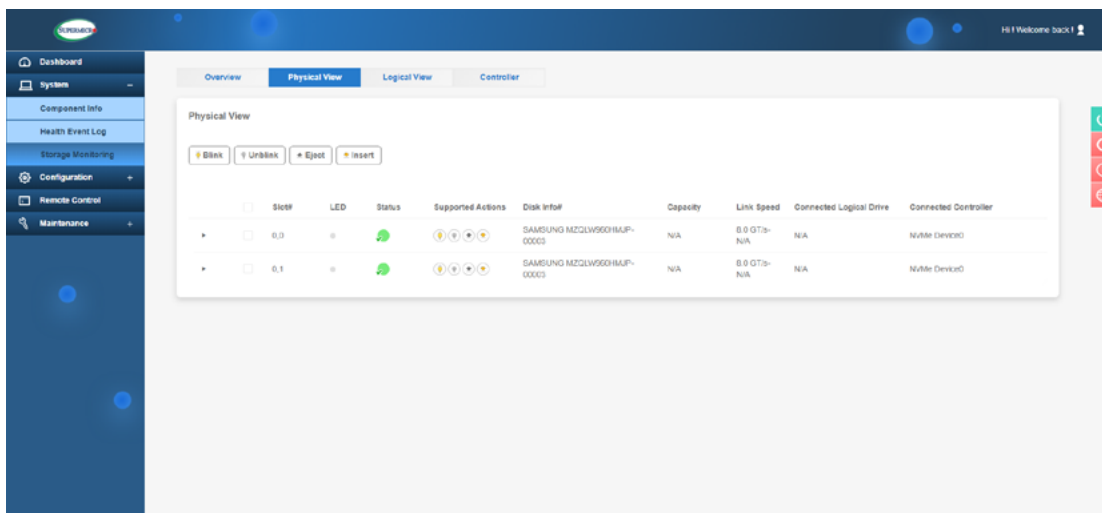

Figure 3-8. BMC Screenshot

Replacing the Drive

1. Insert the replacement drive.
2. **BMC > System > Storage Monitoring > Physical View**
3. Select Device, Group and slot and click **Insert**. The drive Status LED indicator flashes red, then turns off. The Activity LED turns blue.

Checking the Temperature of an NVMe Drive

There are two ways to check using BMC.

Checking a Drive

- **BMC > Server Health > NVMe SSD** – Shows the temperatures of all NVMe drives.
- **BMC > Server Health > Sensor Reading > NVME_SSD** – Shows the single highest temperature among all the NVMe drives.

Adding an Expansion Card

The CSE-827BQ2-R3K04P chassis supports expansion cards. Riser cards are used to mount the expansion cards. Each node can accommodate two low-profile, half-length x16 PCIe cards.

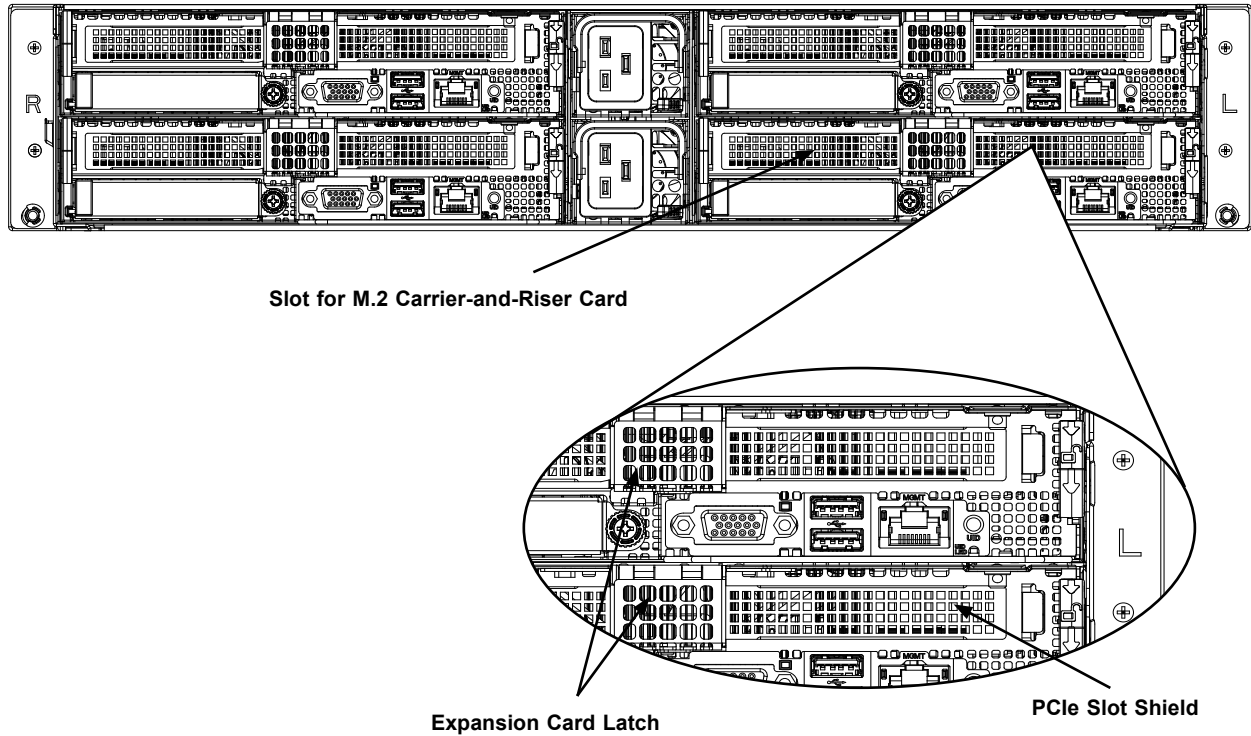

Figure 3-9. Expansion Slot Locations

Installing PCIe 5.0 x16 Expansion Card

1. If necessary, **power down** the node and remove it **from the chassis**.
2. Open the latch at the center of the node and remove the I/O slot shield by sliding it towards the center.
3. Attach the riser card to the riser card bracket and insert the expansion card into the riser card slot. The expansion card to install for SYS-621BT-HNTR/-HNC8R is RSC-PR-6G5.
4. Align the assembly with slots on the motherboard and the PCI slot shield at the node rear. Insert the assembly into the motherboard.
5. Connect cables. See [Section 3.11 Cable Routing Diagram](#).
6. Close the latch, reinsert the node into the chassis, and power up the system.

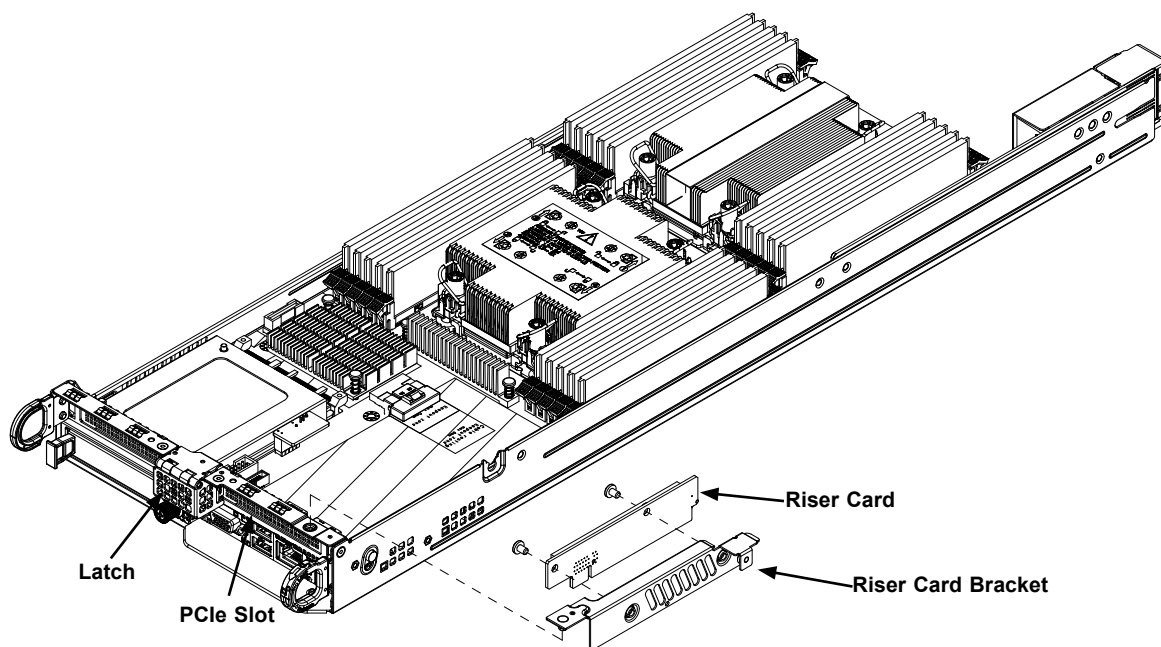

Figure 3-10. Installing an Expansion Card

Note: Figure is for illustrative purposes only. Your system may or may not resemble this picture.

Installing M.2 Carrier-and-Riser Card

1. Power down the node and remove it from the chassis.
2. Remove the expansion card screw (See Figure 3-10) and set aside. Remove the PCI slot shield.
3. Attach brackets onto the M.2 carrier-and-riser card, if necessary.
4. Insert an expansion card into the riser slot of the M.2 carrier-and-riser card to create an assembly (not shown).
5. Install the M.2 SSD, if necessary.

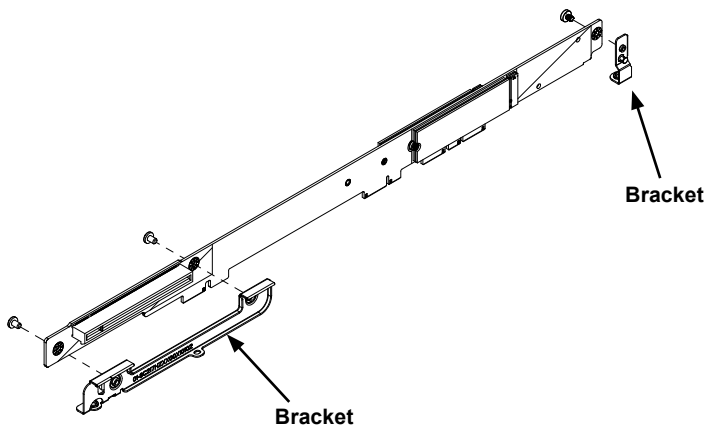

Figure 3-11. Installing Brackets

6. Align the assembly with SLOT2 on the motherboard and the PCI slot shield at the node rear and insert the assembly into the motherboard.
7. Reinstall the expansion card screw, reinsert the node into the chassis, and power up the system.

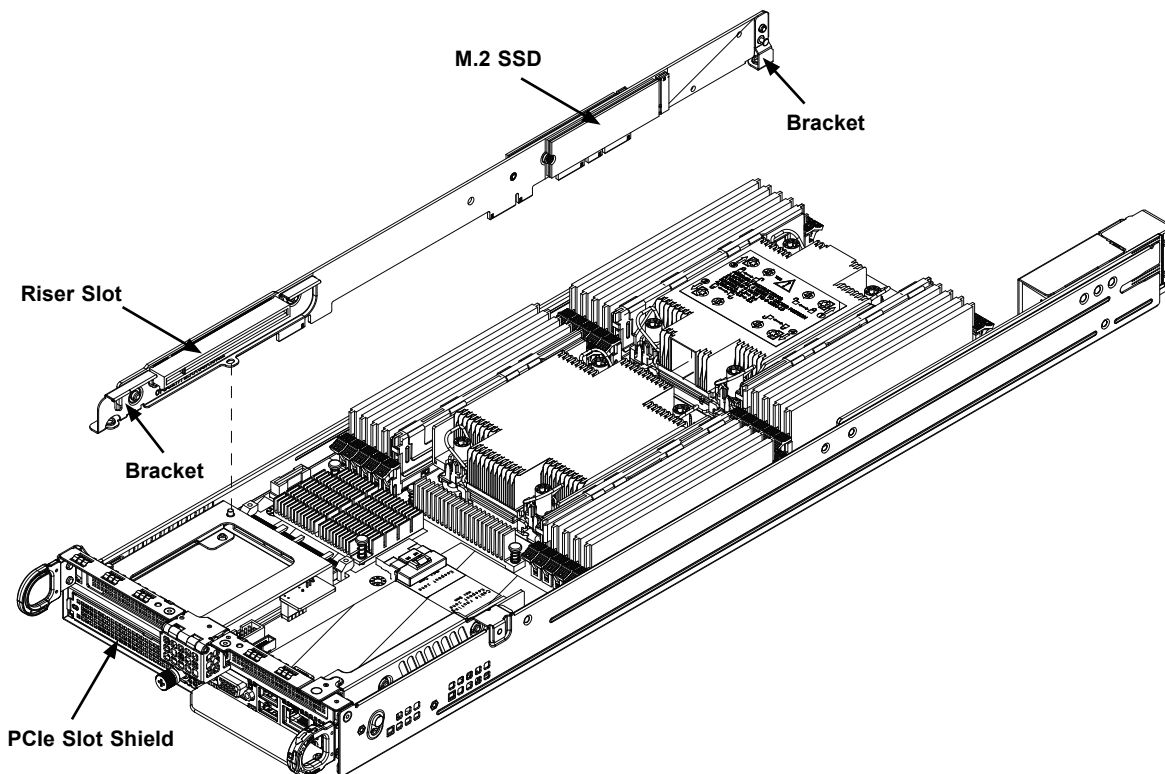

Figure 3-12. Installing Expansion Card onto M.2 Carrier-and-Riser Card

AIOM Card

The Supermicro Advanced Input/Output Module (AIOM) card provides options for network connection. It is inserted into an AIOM slot on the motherboard tray.

Removing the AIOM Card

1. Press the release tab and loosen the thumbscrew on the AIOM card.
2. Grasp the release tab and the thumbscrew and pull the AIOM out of the node tray.

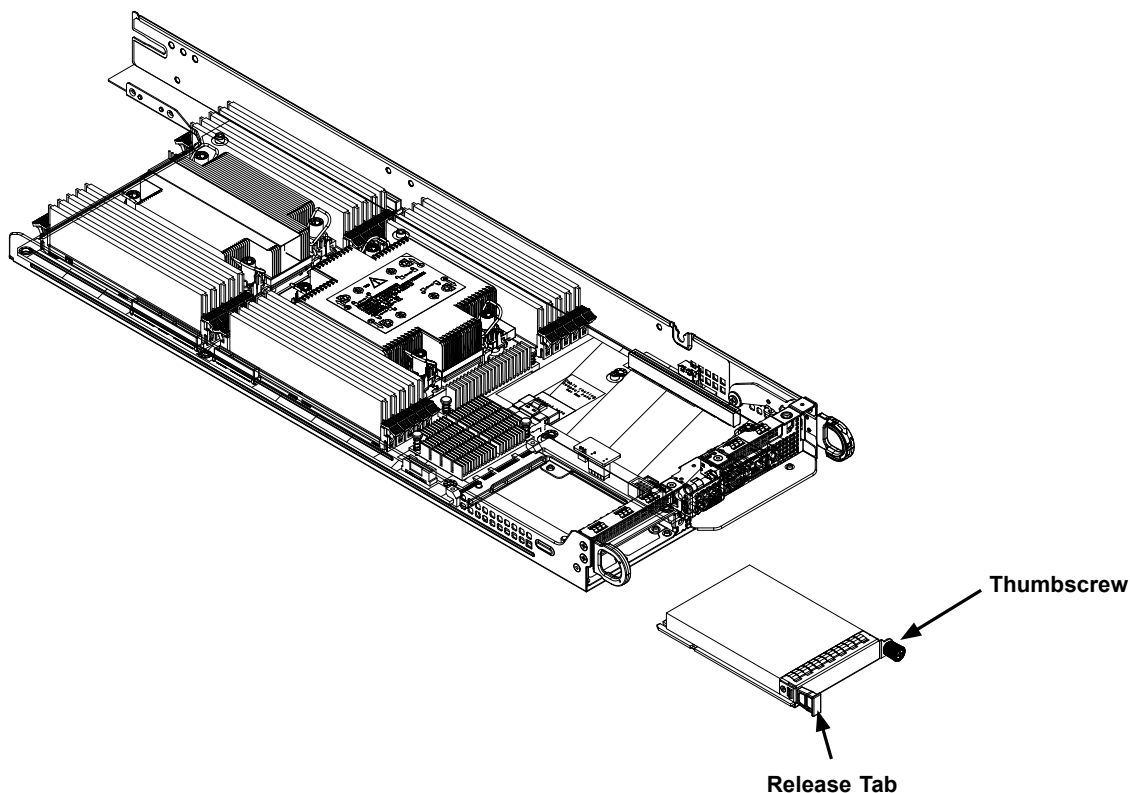

Figure 3-13. AIOM Card Position on Node Drawer Rear

Installing the AIOM Card

1. If necessary, loosen the thumbscrew and remove the shield.
2. Insert the AIOM card into the motherboard tray slot as shown until the release tab retracts.
3. Tighten the thumbscrew.

3.9 System Cooling

Fans

Fan speed is controlled by a system temperature setting in BMC. If a fan fails, the remaining fans will ramp up to full speed. The system can continue to run with a failed fan. Replace any failed fan at your earliest convenience with the same type and model.

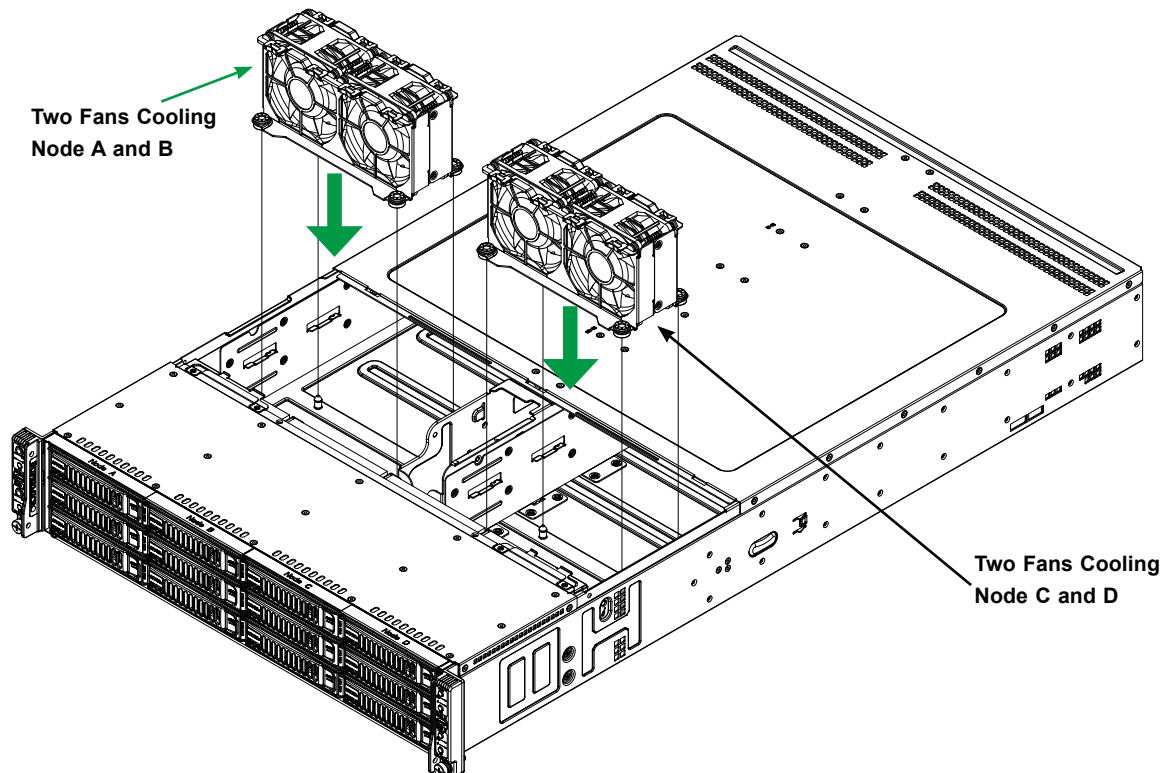

Figure 3-14. System Fan Placement

Changing a System Fan

1. Determine which fan is failing. If possible, use BMC. If not, remove the chassis cover while the power is on, and examine the fans to determine which one has failed.
2. Remove power from the system as described in [Section 3.1](#).
3. Remove the fan cable from the backplane for the failed fan and the adjacent fan.
4. Lift the fan housing up and out of the chassis.
5. Push the fan up from the bottom and out of the top of the housing.

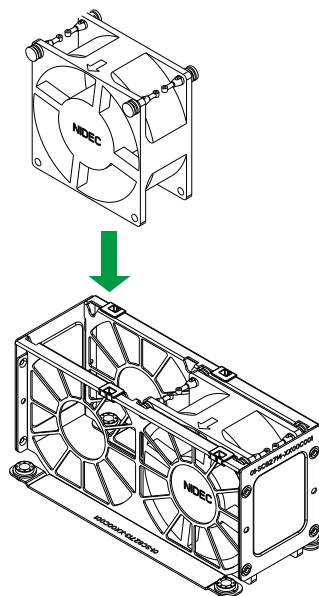

Figure 3-15. Replacing a System Fan in the Fan Housing

6. Place the replacement fan into the vacant space in the housing while making sure the arrows on the top of the fan (indicating air direction) point in the same direction as the arrows on the other fans.
7. Put the fan housing back into the chassis and reconnect the cable.
8. Power on the system to confirm that the fan is working properly before replacing the chassis cover.

Installing the Air Shroud

The system requires air shrouds for each node to maximize airflow efficiency.

Installing the Air Shrouds

The motherboard, any expansion cards, and all components must be installed in the node tray. Place the air shroud as pictured and secure with a screw.

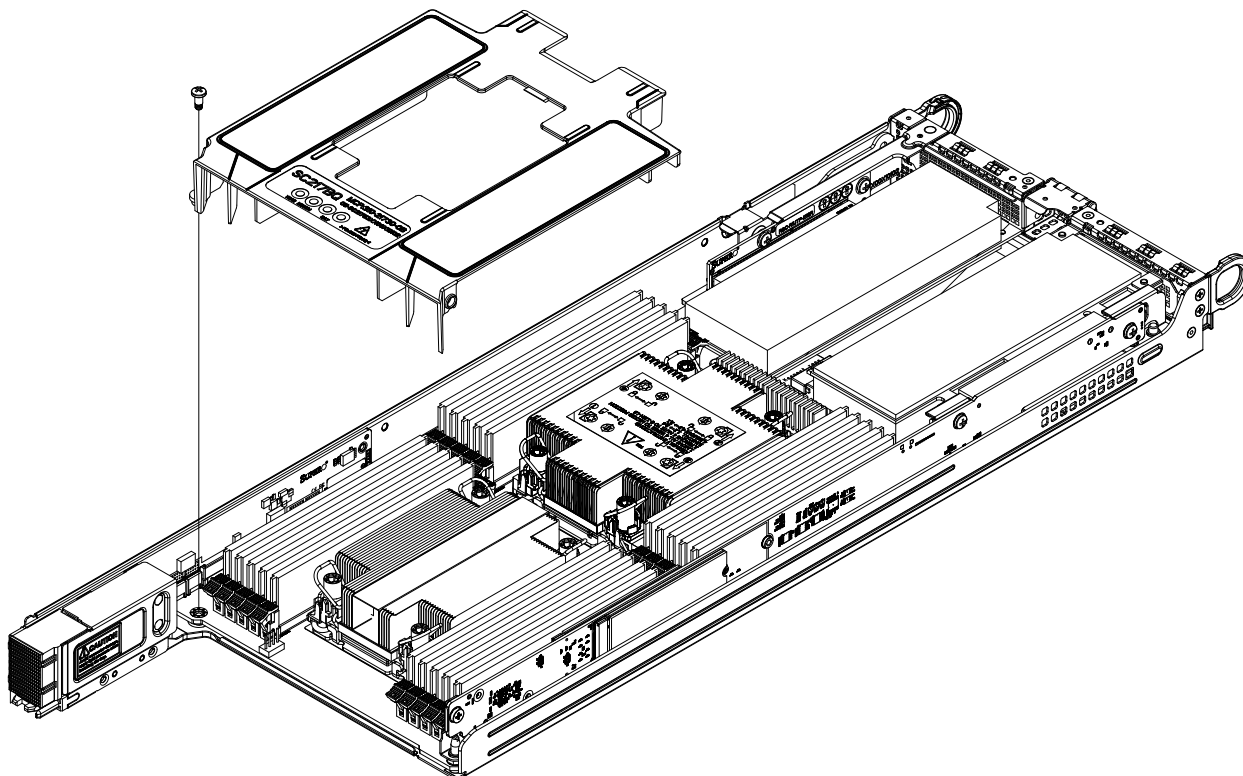

Figure 3-16. Installing the Air Shrouds

Checking the Airflow

Checking the Airflow

- Make sure there are no objects obstructing the airflow in and out of the chassis.
- Except for brief periods while swapping hard drives, do not operate the server without the drive carriers in the drive bays.
- Make sure no wires or foreign objects obstruct airflow through the chassis. Pull all excess cabling out of the airflow path or use shorter cables.

3.10 Power Supply

The chassis features redundant power supplies. The power modules can be changed without powering down the system. New units can be ordered directly from Supermicro or authorized distributors.

These power supplies are auto-switching capable. This feature enables them to automatically sense the input voltage and operate at a 100-120v or 180-240v. An amber light will be illuminated on the power supply when the power is off. An illuminated green light indicates that the power supply is operating.

Important: Power supply redundancy is supported only with a 240 VAC or 240 VDC input.

Replacing the Power Supply

1. Unplug the AC cord from the module to be replaced.
2. Push the release tab on the back of the power supply as illustrated.

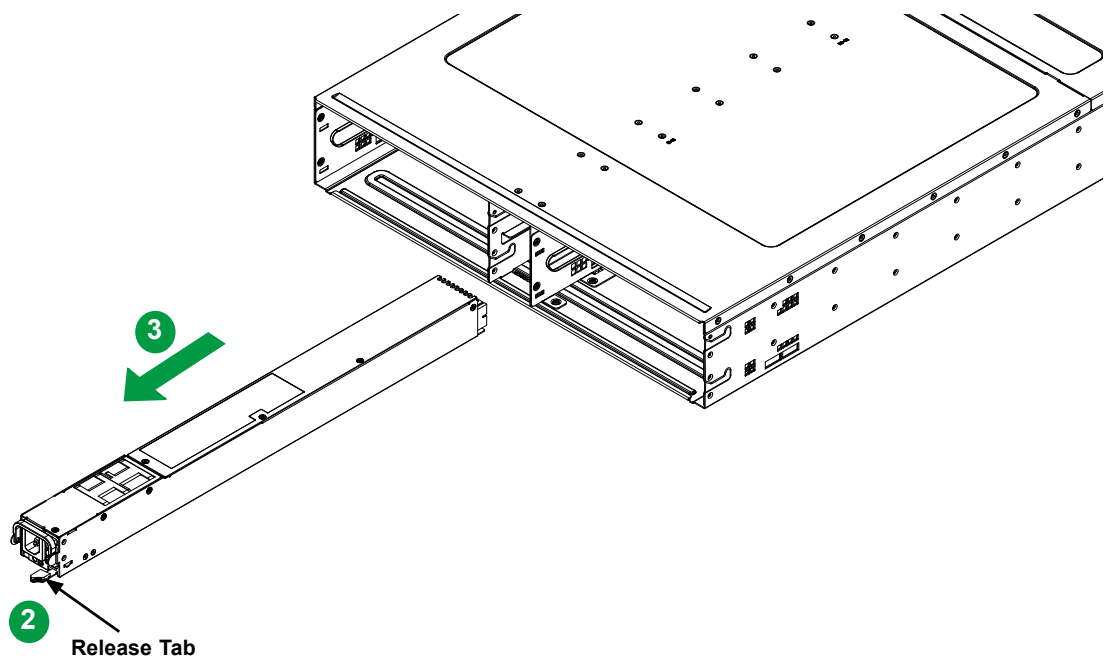

Figure 3-17. Power Supply Release Tab

3. Pull the power supply out using the handle provided.
4. Replace the failed power module with the same model.
5. Push the new power supply module into the power bay until it clicks.
6. Plug the AC power cord back into the module.

3.11 Cable Routing Diagram

Refer to the diagram below for a representation of how the storage cables are routed through the node. When disconnecting cables to add or replace components, refer to this diagram so you can reroute them in the same manner.

NVMe and SATA

NVMe PCIe 5.0 Cable

CBL-NSH5-1326

SATA Cable

CBL-SAST-1243-100

[Online Cable Matrix](#)

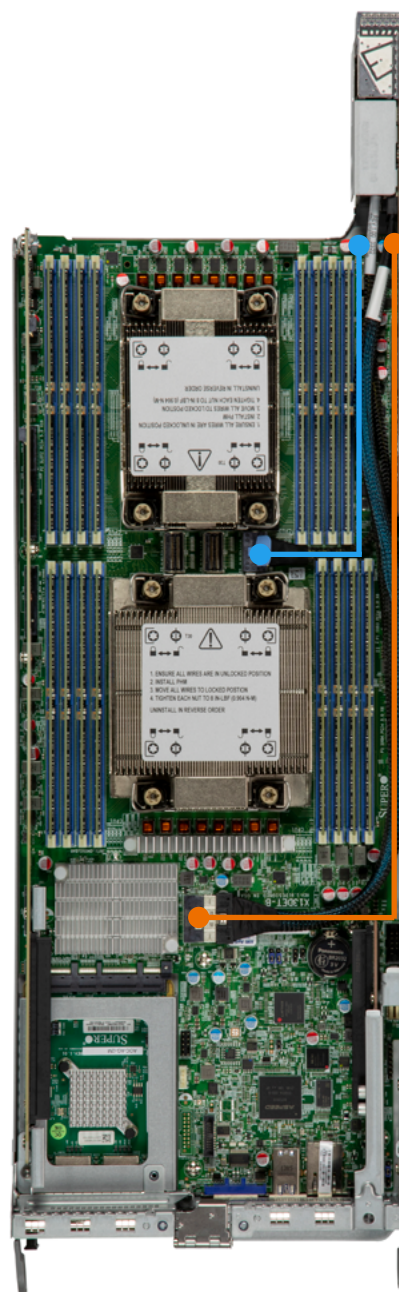

Single Node

Figure 3-18. Cable Routing Diagram (NVMe and SATA)

NVMe and SAS via onboard 3808 Card

NVMe connections from the backplane to the motherboard. SAS connections from the backplane to the SCC-B8SB80-B1. The SCC-B8SB80-B1 connects to the motherboard SXB4. The SXB3 is blocked by the SCC-B8SB80-B1 and is unusable.

NVMe PCIe 5.0 Cable

CBL-NSH5-1326

SAS Cable

CBL-SAST-1221-100

[Online Cable Matrix](#)

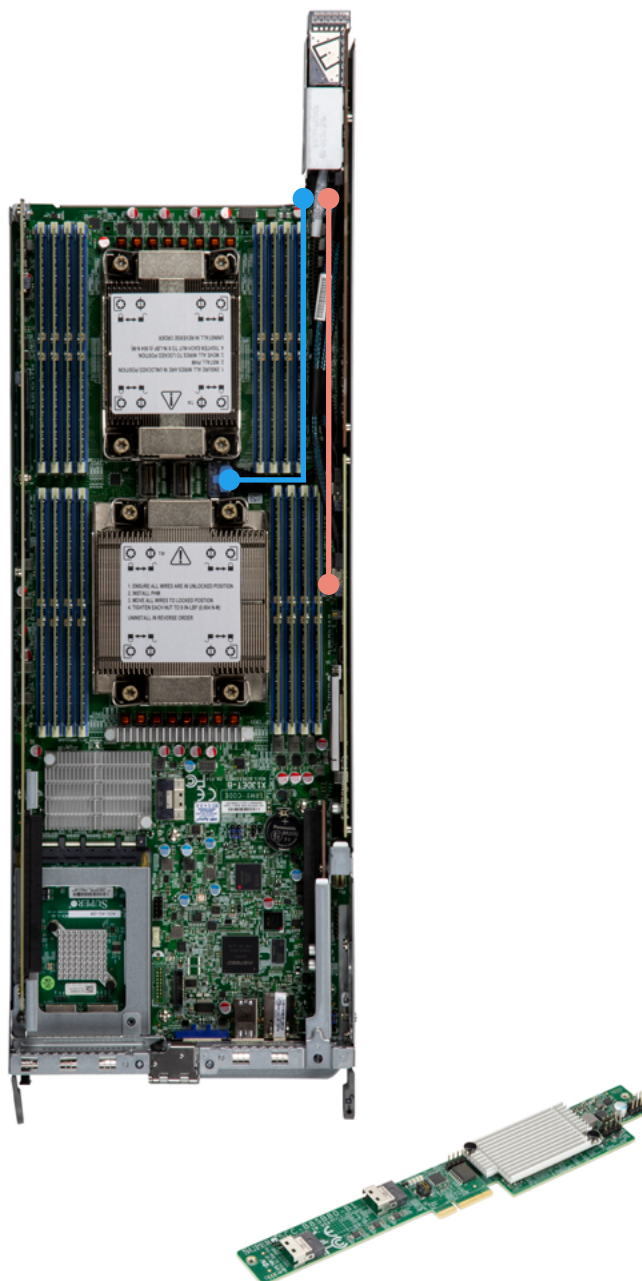

Figure 3-19. Cable Routing Diagram (NVMe and SAS via onboard 3808 Card)

Chapter 4

Motherboard Connections

This section describes the connections on the motherboard and provides pinout definitions. Note that depending on how the system is configured, not all connections are required. The LEDs on the motherboard are also described here. A motherboard layout indicating component locations may be found in [Chapter 1](#). More detail can be found in the [Motherboard Manual](#). Please review the Safety Precautions in [Appendix A](#) before installing or removing components.

4.1 Power Connections

Power Supply Connectors

Four 6-pin power connectors, located at JPWR1 ~ JPWR4, provide main power to your system. All these power connectors meet the ATX SSI EPS 12 V specification and must be connected to your power supply to provide adequate power to your system.

Important: To provide adequate power to your system, be sure to connect the four 6-pin power connectors (JPWR1 ~ JPWR4) to the power supply. Failure to do so may void the manufacturer warranty on your power supply and motherboard.

4.2 Headers and Connectors

VROC RAID Key Header

A VROC RAID Key header is located at JRK1 on the motherboard. Install a VROC RAID Key on JRK1 for NVMe RAID support as shown in the illustration below.

Note: For detailed instructions on how to configure VROC RAID settings, please refer to the VROC RAID Configuration User's Guide posted on the web page under the link: <http://www.supermicro.com/support/manuals/>.

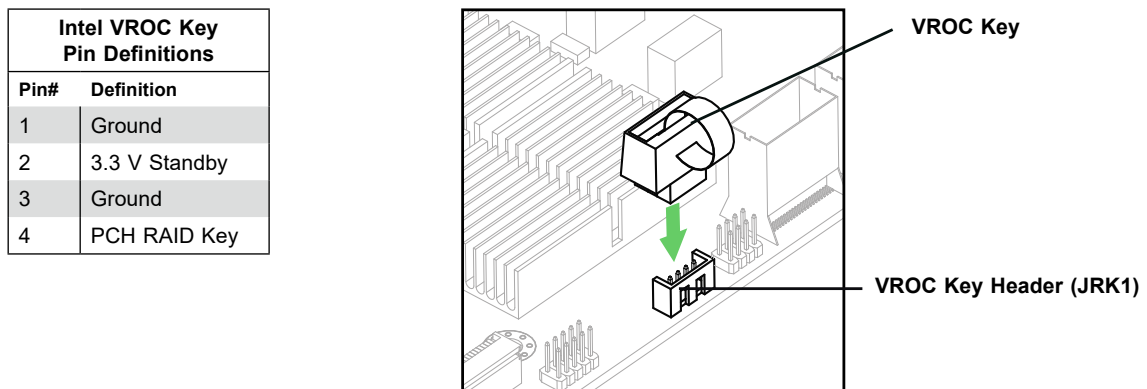

Note: The graphics contained in this user's manual are for illustration only. The components installed in your system may or may not look exactly the same as the graphics shown in the manual.

TPM/Port 80 Header

The JTPM1 header is used to connect a Trusted Platform Module (TPM)/Port 80, which is available from Supermicro (optional). A TPM/Port 80 connector is a security device that supports encryption and authentication in hard drives. It allows the motherboard to deny access if the TPM associated with the hard drive is not installed in the system. Go to the following link for more information on the TPM: <http://www.supermicro.com/manuals/other/TPM.pdf>.

Trusted Platform Module Header Pin Definitions			
Pin#	Definition	Pin#	Definition
1	+3.3 V	2	SPI_CS#
3	RESET#	4	SPI_MISO
5	SPI_CLK	6	GND
7	SPI_MOSI	8	NC
9	+3.3 V Stdby	10	SPI_IRQ#

NC-SI Connector

The NC-SI (Network Controller Sideband Interface) connector is located at (JNCSI1). This connector is used to connect a Network Interface Card (NIC) to the motherboard to allow the onboard BMC (Baseboard Controller) to communicate with a network.

Note: For detailed instructions on how to configure Network Interface Card (NIC) settings, please refer to the Network Interface Card Configuration User's Guide posted on the web page under the link: <http://www.supermicro.com/support/manuals/>.

P1 NS1/P2 NS2/P2 NS3 Connectors

Three PCIe 5.0 x8 connectors are located at P1 NS1, P2 NS2, and P2 NS3 headers. P1 NS1 PCIe 5.0 x8 connector (NS1) is supported by CPU1, while P2 NS2 5.0 x8 (NS2) and P2 NS3 5.0 x8 (NS3) are supported by CPU2. Refer to the motherboard layout in Chapter 1 for the locations.

SATA 3.0 Ports 0~7/8~11

Two SATA 3.0 headers, located at (SATA1/SATA2), support 12 SATA 3.0 connections (SATA 0~7 and SATA 8~11). These SATA 3.0 ports are supported by the Intel chipset. Connecting proper SATA cables to SATA1 and SATA2 to use SATA 3.0 connections.

AIOM PCIe 5.0 x16 Slot (JAIOM)

A PCIe 5.0 x16 slot, supported by CPU1, is located at JAIOM. This slot is used for an Advanced I/O module or riser card. Refer to the motherboard layout in Chapter 1 for the location.

PCIe 5.0 x8 NVMe M.2 Slot

A PCIe 5.0 x8, located at SXB5, supports two NVMe M.2 connections in the 2280 or 22110 form factor, which depends on the type of the riser card used on the slot. M.2 allows for a variety of card sizes, increased functionality, and spatial efficiency. Refer to the motherboard layout in Chapter 1 for the location.

Note: The SXB5 slot supports the SCC-P2HM2G4-B1 and the SCC-A2NM2241G3-B1. The SCC-P2HM2G4-B1 supports two NVMe M.2 devices (up to Gen 4) in the 22110 form factor, and the SCC-A2NM2241G3-B1 supports two NVMe M.2 devices (up to Gen 3) in the 2280 form factor.

4.3 Input/Output Ports

UID/BMC Reset Switch and UID_LED/BMC LED Indicator

A UID LED/BMC Reset switch (JUIDB1) is located on the rear I/O panel of the motherboard. This switch has dual functions. It can function as a unit identifier (UID) to identify a system unit that is in need of service, and it can also be used for BMC reset.

To achieve these purposes, JUIDB1 works in conjunction with the UID_LED1/LEDBMC LED indicator located on the rear I/O panel and the UID/BMC LED indicator on the front panel. When functioning as a UID LED switch, JUIDB1 will turn on/off both blue UID indicators located on the front and the rear panels when the user presses this switch on/off.

When functioning as a BMC reset switch, JUIDB1 will reset the BMC settings to the manufacturer defaults when the user presses and holds the switch for 12 seconds, and it will trigger a cold reboot when the user presses and holds it for 6 seconds.

Refer to the BMC User's Guide posted on our website at <http://www.supermicro.com> for more information.

UID/BMC Reset Switch (JUIDB1) Features & Settings					
When Used as a UID LED Switch	When Used as a BMC Reset Switch				
UID_LED1/LEDBM acting as a rear UID LED indicator	UID_LED1/LEDBMC acting as a BMC Reset LED indicator.				
UID_LED1/LEDBMC: Blue: Unit in need of services is identified	UID_LED1/LEDBMC: Green Blinking: BMC (BMC Heartbeat) Normal				
	<table border="1"> <tr> <td>BMC Reset: Press & hold the switch (JUIDB1) 6 seconds</td> <td>UID_LED1/LEDBMC: Solid green during reboot</td> </tr> <tr> <td></td> <td>Triggering a cold reboot; the UID_LED1/LEDBMC indicator: Solid green on during cold reboot</td> </tr> </table>	BMC Reset: Press & hold the switch (JUIDB1) 6 seconds	UID_LED1/LEDBMC: Solid green during reboot		Triggering a cold reboot; the UID_LED1/LEDBMC indicator: Solid green on during cold reboot
BMC Reset: Press & hold the switch (JUIDB1) 6 seconds	UID_LED1/LEDBMC: Solid green during reboot				
	Triggering a cold reboot; the UID_LED1/LEDBMC indicator: Solid green on during cold reboot				
Press the switch (JUIDB1) on/off to turn on/off both rear UID LED (located at UID_LED1/LEDBMC LED) and front UID LED (located on the front control panel) for UID indications	<table border="1"> <tr> <td>BMC Reset: Press & hold the switch (JUIDB1) 12 seconds</td> <td>UID_LED1/LEDBMC: Solid green during BMC reset</td> </tr> <tr> <td></td> <td>BMC: Reset to the manufacturer default; UID_LED1/LEDBMC: Solid on during BMC Reset</td> </tr> </table>	BMC Reset: Press & hold the switch (JUIDB1) 12 seconds	UID_LED1/LEDBMC: Solid green during BMC reset		BMC: Reset to the manufacturer default; UID_LED1/LEDBMC: Solid on during BMC Reset
	BMC Reset: Press & hold the switch (JUIDB1) 12 seconds	UID_LED1/LEDBMC: Solid green during BMC reset			
	BMC: Reset to the manufacturer default; UID_LED1/LEDBMC: Solid on during BMC Reset				

UID/BMC Reset Switch (JUIDB1) Pin Definitions	
Pin#	Definition
1	Ground
2	Ground
3	Button In
4	Button In

VGA Port

A VGA port is located at JVGA1 on the rear I/O panel. This VGA port provides analog interface between the computer and the video displays.

COM Port

A COM (communication) port that supports serial link interface is located on the rear side of the motherboard. Refer to the motherboard layout in Chapter 1 for the location.

BMC LAN

A dedicated BMC LAN (BMC LAN) is located on the rear I/O panel. The dedicated BMC LAN provides LAN support for the BMC (Baseboard Management Controller). Connect an RJ45 cable to JUSBRJ45 on the I/O rear panel for BMC LAN support.

Universal Serial Bus (USB) Ports and Headers

There are two USB 3.1 ports (USB0/1), located at JUSB1, on the rear I/O panel. These USB ports and headers can be used for USB support via USB cables (not included).

Rear I/O Panel USB 0/1 (3.1) Pin Definitions			
Pin#	Definition	Pin#	Definition
A1	VBUS	B1	Power
A2	D-	B2	USB_N
A3	D+	B3	USB_P
A4	GND	B4	GND
A5	Stda_SSRX-	B5	USB3_RN
A6	Stda_SSRX+	B6	USB3_RP
A7	GND	B7	GND
A8	Stda_SSTX-	B8	USB3_TN
A9	Stda_SSTX+	B9	USB3_TP

4.4 Jumpers

How Jumpers Work

To modify the operation of the motherboard, jumpers can be used to choose between optional settings. Jumpers create shorts between two pins to change the function of the connector. Pin 1 is identified with a square solder pad on the printed circuit board. Refer to the diagram below for an example of jumping pins 1 and 2. Refer to the X13DET-B motherboard layout page for jumper locations.

Note: On two-pin jumpers, "Closed" means the jumper is on, and "Open" means the jumper is off the pins.

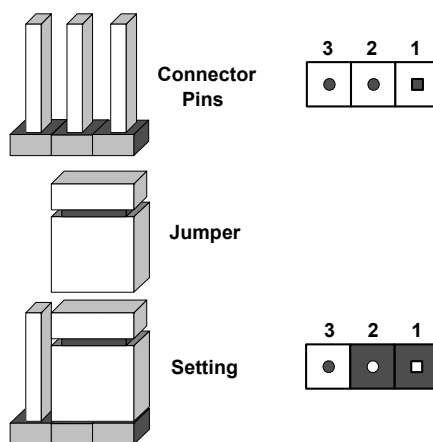

CMOS Clear

JBT1 is used to clear CMOS, which will also clear any passwords. Instead of pins, this jumper consists of contact pads to prevent accidentally clearing the contents of CMOS.

To Clear CMOS

1. First power down the system and unplug the power cord(s). 
2. Remove the cover of the chassis to access the motherboard and remove the battery from the motherboard.
3. Short the CMOS pads, JBT1, with a metal object such as a small screwdriver for at least four seconds.
4. Remove the screwdriver (or shorting device).
5. Replace the cover, reconnect the power cord(s), and power on the system.

Note 1: Clearing CMOS will also clear all passwords.

Note 2: Do not use the PW_ON connector to clear CMOS.

ME Recovery

JPME1 is used for ME Firmware Recovery mode, which will limit system resource for essential function use only without putting restrictions on power use. In the single operation mode, online upgrade will be available via Recovery mode. See the table below for pin definitions.

ME Recovery (JPME1) Jumper Settings	
Jumper Setting	Definition
Pins 1-2	Normal (Default)
Pins 2-3	ME Recovery

ME (Manufacture Mode) Select

Use Jumper JPME2 to set ME Mode for your system to enhance your system performance. See the table below for pin definitions.

ME Select (JPME2) Jumper Settings	
Jumper Setting	Definition
Pins 1-2	ME Mode Enabled (Default)
Pins 2-3	ME Mode Disabled

4.5 LED Indicators

BMC LAN LEDs

A dedicated BMC LAN connection, located on the rear I/O panel, provides Ethernet network connection via the BMC (Baseboard Management Control). The LED on the right indicates activity, and the LED on the left indicates the speed of the connection. Refer to the table below for more information.

BMC LAN LEDs		
	Color/State	Definition
Link (Left)	Green: Solid Amber: Solid	100 Mbps 1Gbps
Activity (Right)	Amber: Blinking	Active

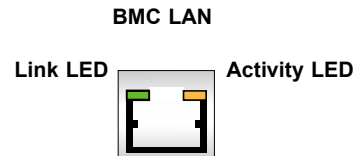

CPLD Heartbeat LED

A Complex Programmable Heartbeat LED indicator is located at LE1. When this LED is on, CPLD is active. Refer to the motherboard layout in Chapter 1 for the location.

CPLD Heartbeat LED (LE1) LED State	
State	Definition
On	CPLD Active (Normal)

Power Status LED

The Power Status LED, located at LE6, indicates the status of onboard power. When this LED turns red, it indicates a power failure. When this LED is green, onboard power is on. When the LED turns amber, the standby power is on. Refer to the motherboard layout in Chapter 1 for the location.

Power Status LED (LE6) LED State	
Color	Definition
Green	Power On
Amber	Standby Power On
Red	Power Failure

Chapter 5

Software

After the hardware has been installed, you can install the Operating System (OS), configure RAID settings and install the drivers.

5.1 Microsoft Windows OS Installation

If you will be using RAID, you must configure RAID settings before installing the Windows OS and the RAID driver. Refer to the RAID Configuration User Guides posted on our website at www.supernmicro.com/support/manuals.

Installing the OS

1. Create a method to access the MS Windows installation ISO file. That might be a media drive, perhaps using an external USB/SATA drive, or a USB flash drive, or the BMC KVM console.
2. Retrieve the proper RST/RSTe driver. Go to the Supermicro web page for your motherboard and click on "Download the Latest Drivers and Utilities", select the proper driver, and copy it to a USB flash drive. For Driver Installation instructions see [Section 5.2](#).
3. Boot from a bootable device with Windows OS installation. You can see a bootable device list by pressing F11 during the system startup.

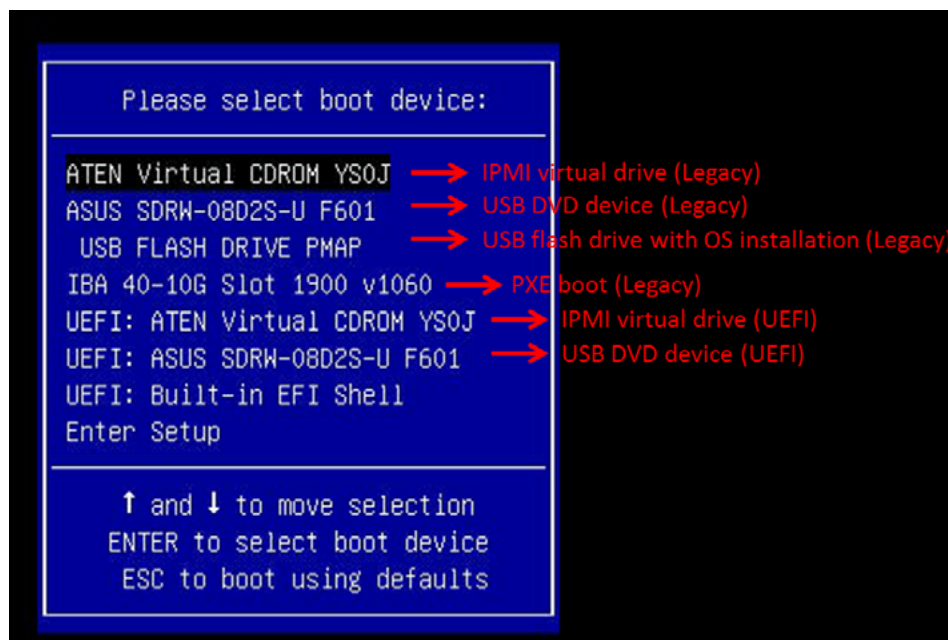

Figure 5-1. Select Boot Device

4. During Windows Setup, continue to the dialog where you select the drives on which to install Windows. If the disk you want to use is not listed, click on “Load driver” link at the bottom left corner.

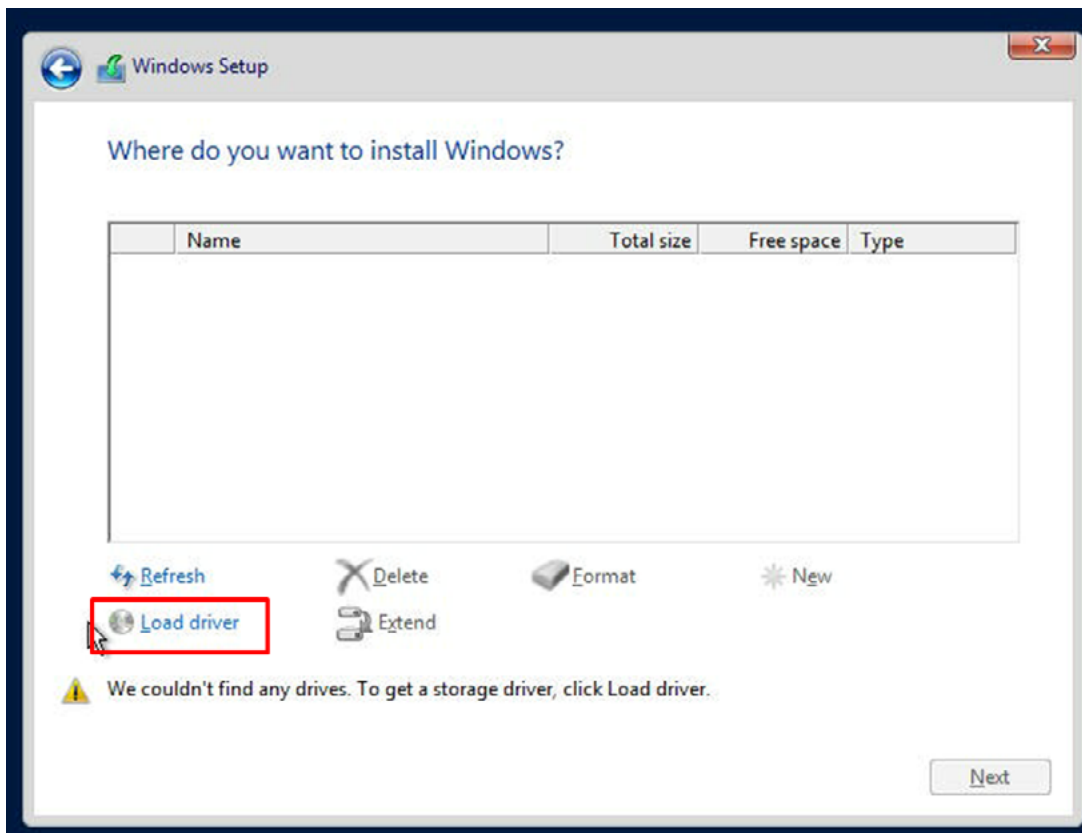

Figure 5-2. Load Driver Link

To load the driver, browse the USB flash drive for the proper driver files.

- For RAID, choose the SATA/sSATA RAID driver indicated then choose the storage drive on which you want to install it.
 - For non-RAID, choose the SATA/sSATA AHCI driver indicated then choose the storage drive on which you want to install it.
5. Once all devices are specified, continue with the installation.
 6. After the Windows OS installation has completed, the system will automatically reboot multiple times.

5.2 Driver Installation

The Supermicro website contains drivers and utilities for your system at <https://www.supermicro.com/wdl/driver>. Some of these must be installed, such as the chipset driver.

After accessing the website, go into the CDR_Images (in the parent directory of the above link) and locate the ISO file for your motherboard. Download this file to a USB flash or media drive. (You may also use a utility to extract the ISO file if preferred.)

Another option is to go to the Supermicro website at <http://www.supermicro.com/products/>. Find the product page for your motherboard, and "Download the Latest Drivers and Utilities". Insert the flash drive or disk and the screenshot shown below should appear.

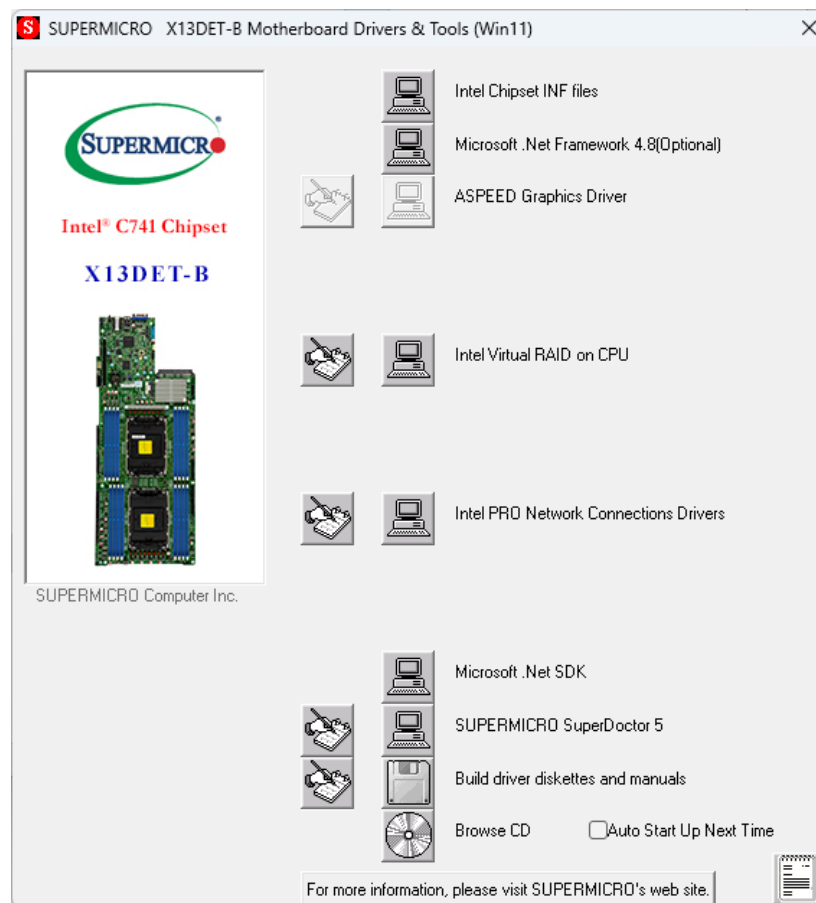

Figure 5-3. Driver & Tool Installation Screen

Note: Click the icons showing a hand writing on paper to view the readme files for each item. Click the computer icons to the right of these items to install each item (from top to the bottom) one at a time. After installing each item, you must re-boot the system before moving on to the next item on the list. The bottom icon with a CD on it allows you to view the entire contents.

5.3 SuperDoctor® 5

The Supermicro SuperDoctor 5 is a program that functions in a command-line or web-based interface for Windows and Linux operating systems. The program monitors such system health information as CPU temperature, system voltages, system power consumption, fan speed, and provides alerts via email or Simple Network Management Protocol (SNMP).

SuperDoctor 5 comes in local and remote management versions and can be used with Nagios to maximize your system monitoring needs. With SuperDoctor 5 Management Server (SSM Server), you can remotely control power on/off and reset chassis intrusion for multiple systems with SuperDoctor 5 or BMC. SuperDoctor 5 Management Server monitors HTTP, FTP, and SMTP services to optimize the efficiency of your operation.

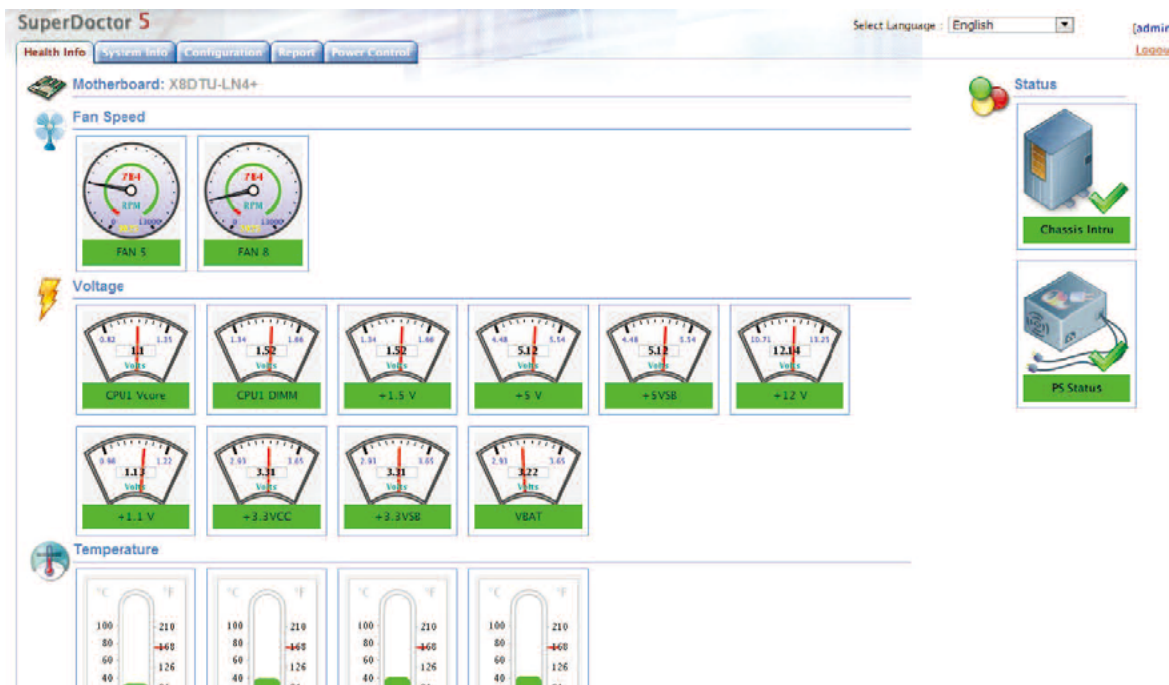

Figure 5-4. SuperDoctor 5 Interface Display Screen (Health Information)

5.4 BMC

The X13DET-B motherboard supports the Baseboard Management Controller (BMC). BMC is used to provide remote access, monitoring and management. There are several BIOS settings that are related to BMC.

For general documentation and information on BMC, please visit our website at:

www.supermicro.com/en/solutions/management-software/bmc-resources

BMC ADMIN User password

Supermicro ships standard products with a unique password for the BMC ADMIN user. This password can be found on a label on the motherboard.

When logging in to the BMC for the first time, please use the unique password provided by Supermicro to log in. You can change the unique password to a user name and password of your choice for subsequent logins.

For more information regarding BMC passwords, please visit our website at <https://www.supermicro.com>.

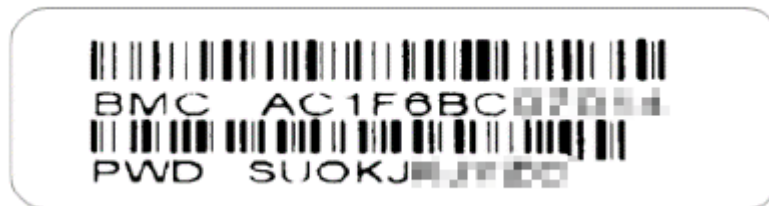

Figure 5-5. BMC Password Label

See [Chapter 1](#) for the location of the labels.

Chapter 6

Optional Components

This chapter describes optional system components and installation procedures.

6.1 Optional Parts List

Optional Parts List	
Description	Part Number
Trusted Platform Module (TPM)	AOM-TPM-9670H-S-O AOM-TPM-9671H-S-O
Virtual RAID on CPU (VROC) Hardware Key	AOC-VROCPREMOD AOC-VROCSTNMOD
M.2 NVMe HW RAID Controller Card	SCC-A2NM2241G3-B1

6.2 M.2 NVMe Carrier Card

See [Chapter 3 Installing M.2 Carrier Card](#) for steps to install the M.2 carrier card and SSDs.

6.3 GPU Support

The SYS-621BT-HNTR and SYS-621BT-HNC8R support up to two NVidia T4 GPUs per node. See [Chapter 3 Installing Expansion Cards](#) for steps to install the NVidia T4 GPUs.

6.4 Intel Virtual RAID on CPU (VROC)

Intel® Virtual RAID on CPU (Intel VROC) is an enterprise RAID solution for NVMe SSDs directly attached to Intel Xeon Scalable processors. Intel Volume Management Device (VMD) is an integrated controller inside the CPU PCIe root complex.

- A single processor supports up to 12 NVMe SSDs and up to 6 RAID arrays.
- A dual processor system supports up to 24 NVMe SSDs and 12 RAID arrays.

Stripe sizes are 4K, 8K, 16K, 32K, 64K, 128K.

Requirements and Restrictions

- **Intel VROC is only available when the system is configured for UEFI boot mode.**
- To enable the **mdadm** command and support for RSTe, install the patch from
 - Linux: <https://downloadcenter.intel.com/download/28158/Intel-Virtual-RAID-on-CPU-Intel-VROC-and-Intel-Rapid-Storage-Technology-enterprise-Intel-RSTe-Driver-for-Linux->
 - Windows: <https://downloadcenter.intel.com/download/28108/Intel-Virtual-RAID-on-CPU-Intel-VROC-and-Intel-Rapid-Storage-Technology-enterprise-Intel-RSTe-Driver-for-Windows->
- To enable Intel VROC, a hardware key must be inserted on the motherboard, and the appropriate processor's Virtual Management Devices must be enabled in the BIOS setup.
- It is possible to enable Intel VROC without a hardware key installed, but only RAID0 will be enabled.
- Intel VROC is not compatible with secure boot. This feature must be disabled.
- When creating bootable OS RAID1 devices, you must have both devices on the same CPU, and a VMD on that CPU.
- Spanning drives when creating RAID devices is not recommended due to performance issues, even though it is supported.

Supported SSDs and Operating Systems

To see the latest support information: <https://www.intel.com/content/www/us/en/support/articles/000030310/memory-and-storage/ssd-software.html>

Additional Information

Additional information is available on the product page for the Supermicro add-on card and the linked manuals.

www.supermicro.com/products/accessories/addon/AOC-VROCxxxMOD.cfm

Hardware Key

The Intel VROC hardware key is a license key that detects the Intel VROC SKU and activates the function accordingly. The key must be plugged into the Supermicro motherboard (connector JRK1). The key options are:

Intel® VROC Keys			
VROC Package	Description	Part Number	Intel MM Number
Standard	RAID 0, 1, 10 Supports 3rd party SSDs	AOC-VROCSTNMOD	951605
Premium	RAID 0, 1, 5, 10 Supports 3rd party SSDs	AOC-VROCPREMOD	951606

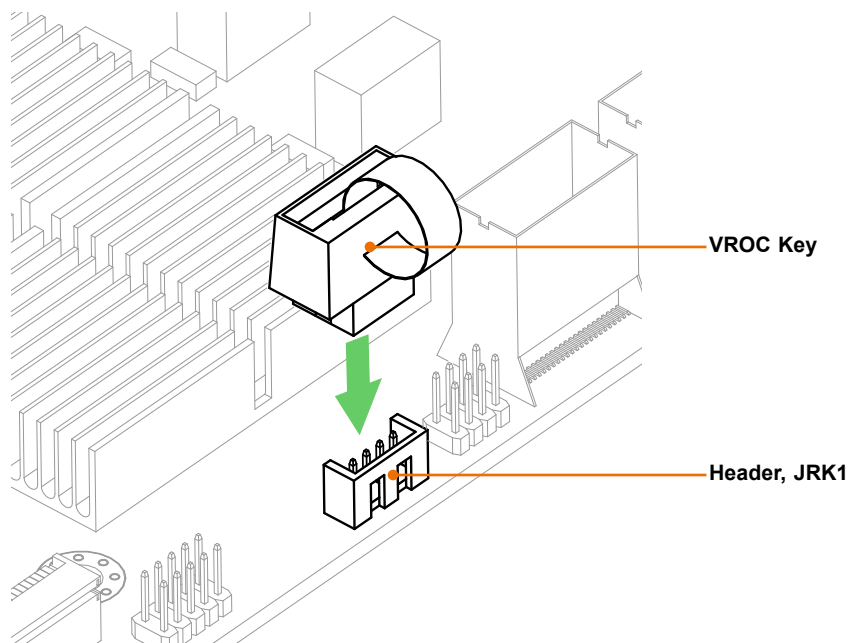

Figure 6-1. Intel VROC RAID Key and Motherboard Connector JRK1

Configuring Intel VMD

VMD must be enabled on PCIe ports which have NVMe drives attached to them in order for those drives to be added to a VROC RAID configuration. The default BIOS setting for the NVMe Mode Switch is **Auto** which automatically enables VMD on all installed NVMe drives.

NVMe Mode Switch :

- **Auto** Enables VMD for all NVMe ports if VROC Key is installed.
- **VMD** Enables VMD for all NVMe ports despite the lack of the VROC Key.
- **Manual** Allows the user to select specific NVMe ports on which to enable VMD.

The NVMe Mode Switch can be viewed or selected at **BIOS > Advanced > Chipset Configuration > North Bridge > IIO Configuration > Intel® VMD Technology**.

Note: Without a VROC Key, there is no RAID support with the **Auto** switch. Only RAID 0 is supported with the **VMD** and **Manual** switches.

Configuring VMD Manually

The steps for manually configuring VMD on specific NVMe ports in UEFI BIOS are shown below. Example screenshots may differ from your server.

1. Reboot the server and press [DEL] key to access the BIOS options.
2. Switch to **Advanced > Chipset Configuration > North Bridge > IIO Configuration > Intel® VMD Technology**.
3. Select **VMD Mode Switch**, then select Manual.

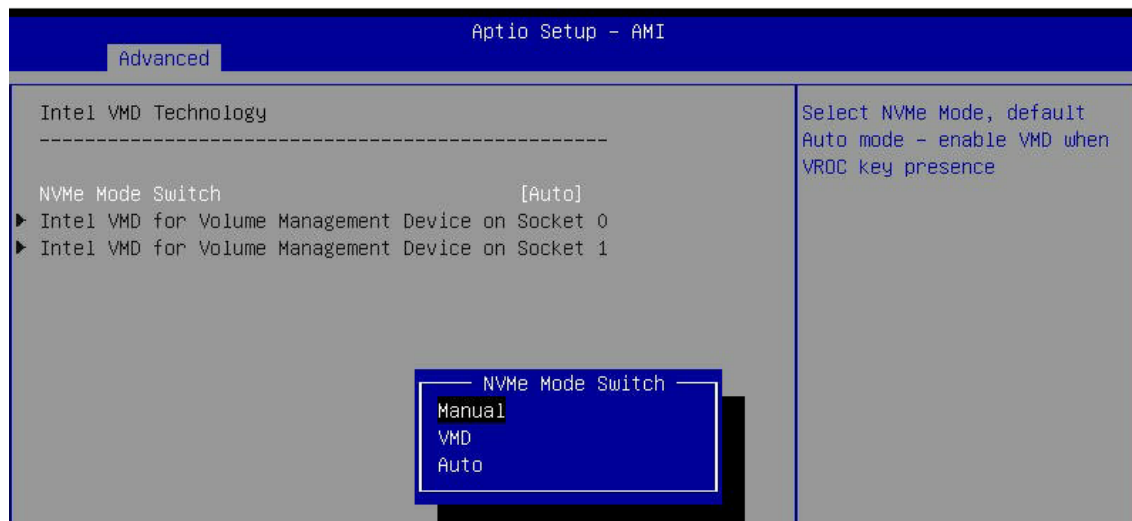

Note that Socket 0 contains CPU1; Socket 1 contains CPU2

Figure 6-2. BIOS, Selecting VMD Mode

Note: Consult the X13DET-B Motherboard Manual for more detailed information on setting up Intel VMD.

Caution: VMD must only be enabled on NVMe port resources. If VMD is enabled on other PCIe ports, the functionality of those ports will be impacted. See the table below.

4. Select “Intel VMD for Volume Management Device on” on Socket 0 (CPU1) or Socket 2 (CPU2) to enable VMD for devices under the respective CPU.

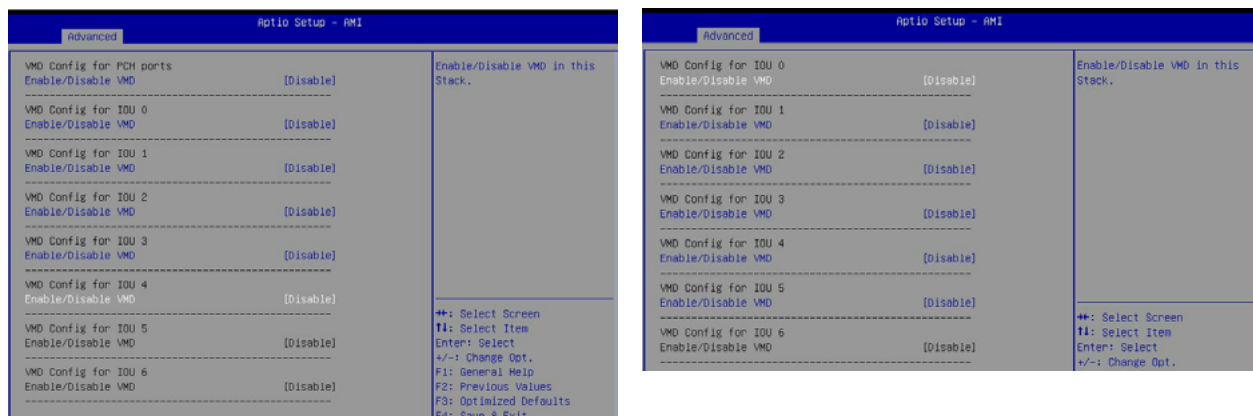

Figure 6-3. Intel VMD for Volume Management Device on Socket 0 and Socket 1

5. Choose Enable for “Enable/Disable VMD” for IOU 3 to list the available devices under

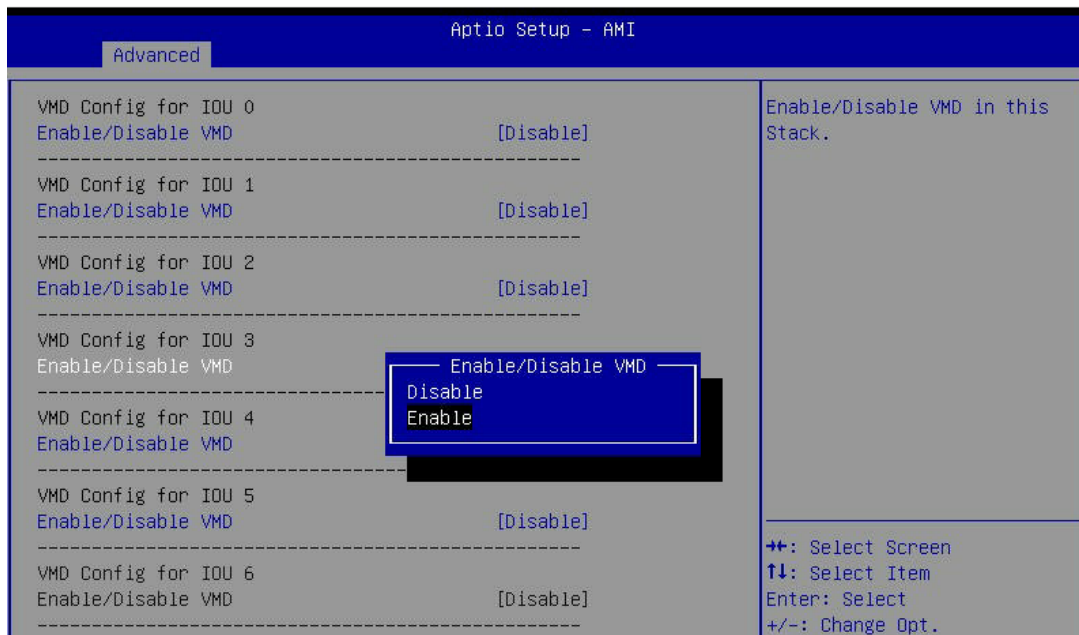

Figure 6-4. BIOS, Enabling VMD on Socket 1 (CPU2) (Example)

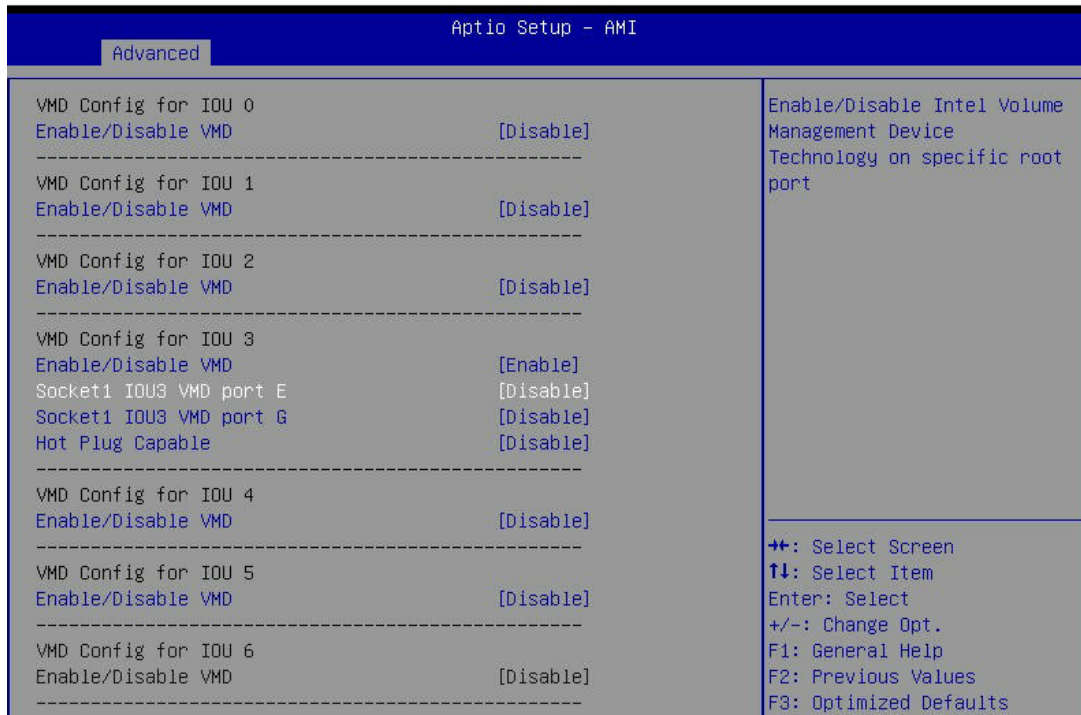

Figure 6-5. BIOS, Enabling VMD on Socket 1 (Example)

6. Enable the NVMe port resource according to table above for the NVMe drives that will be used in a RAID configuration.

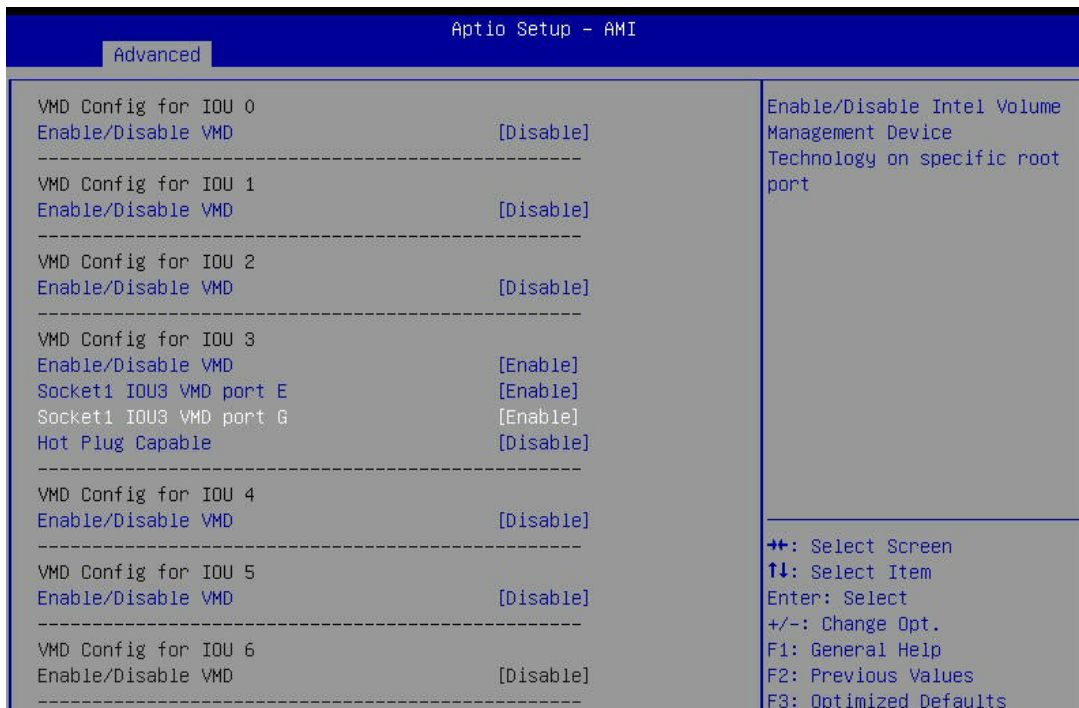

Figure 6-6. BIOS, Enabling Socket 1 (Example)

7. Choose whether to make the NVMe drives in this IOU Hot Plug Capable by selecting Enabled or Disabled.
8. Repeat steps 4 through 7 for each IOU # on each CPU to enable VMD on the desired NVMe ports.

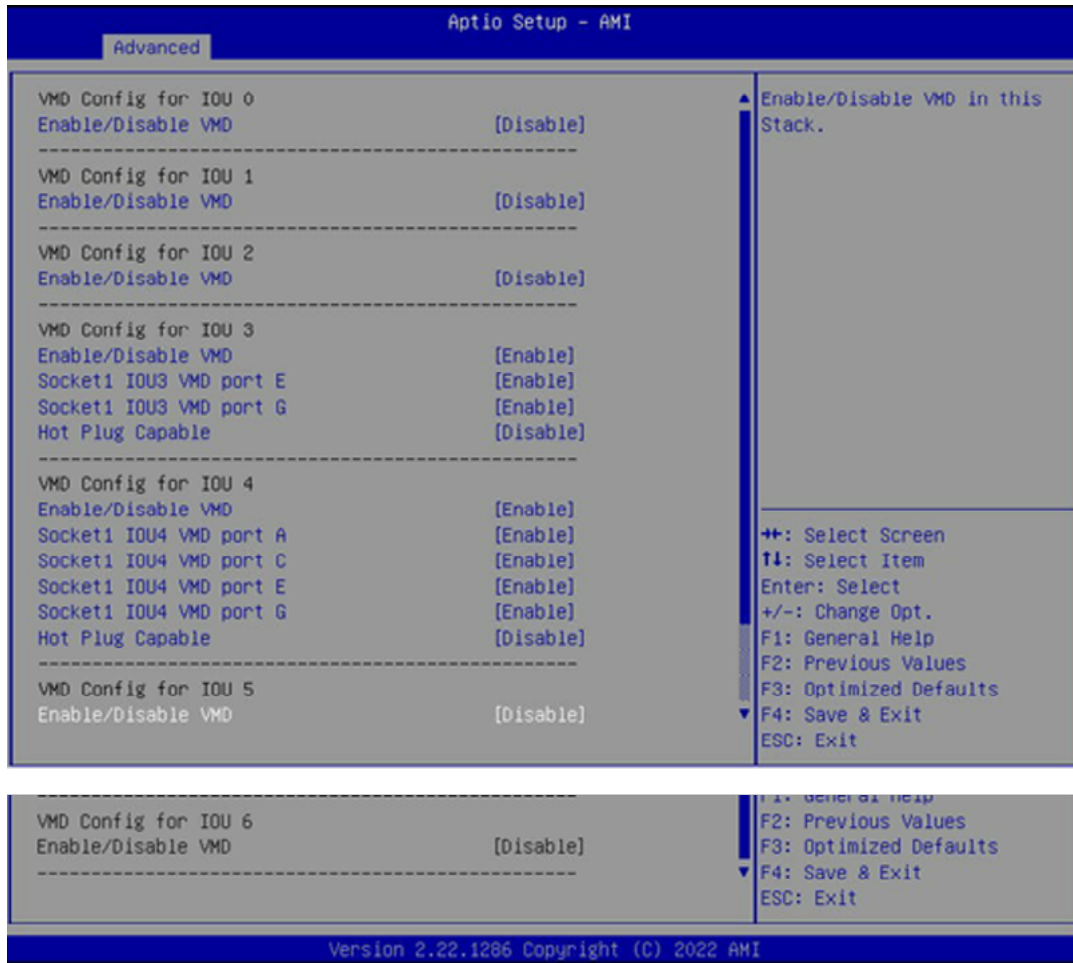

Figure 6-7. BIOS, Enabling Socket 1 Completed (Example)

(This example shows SYS-621H-TN12R with 12 NVMe. Other systems will look different.)

9. Press [F4] to save the configuration and reboot the system.

Note: If there is an existing RAID configuration, delete the RAID volume associated with the VMD controller before disabling the controller. Failure to do so may lead to unexpected behavior.

Note: The effects of physically changing or swapping a CPU on the VMD controller have not been thoroughly tested or documented.

Creating NVMe RAID Configurations

1. Open **Advanced > Intel(R) Virtual RAID on CPU > All Intel VMD Controllers > Create RAID Volume**.

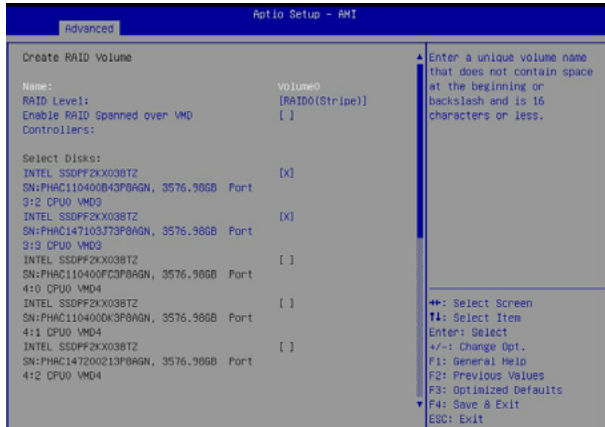

Figure 6-8. Created Volume *without* enabling RAID spanned over VMD controller

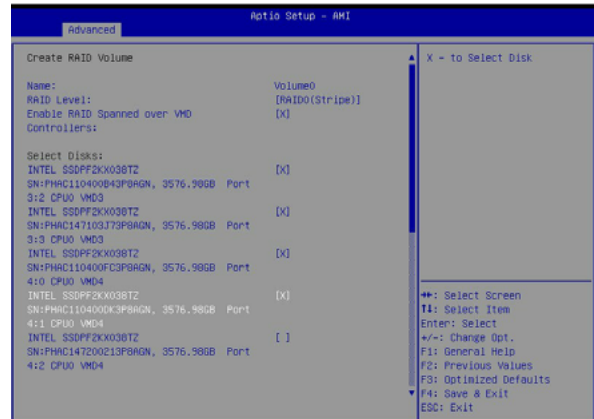

Figure 6-9. Created Volume *with* enabling RAID spanned over VMD controller

2. Set **Name**.
3. Set **RAID Level**.
4. If cross-controller RAID is required, select **Enable RAID spanned over VMD Controller**.
5. Select specific disks for RAID with an [X].
 - RAID0: Select at least two [2 - 24] disks
 - RAID1: Select only two disks
 - RAID5: Select at least three [3 - 24] disks
 - RAID10: Select only four disks
6. Select **Strip Size** (Default 64KB).
7. Select **Create Volume**.
8. If another RAID is needed, start again at step 1.

Status Indications

An LED indicator on the drive carrier shows the RAID status of the drive.

Drive Carrier Status LED Indicator	
Status	State (red)
Normal function	OFF
Locating	4 Hz blink
Fault	Solid ON
Rebuilding	1 Hz Blink

IBPI SFF 8489 Defined Status LED States

Hot-Swap Drives

Intel VMD enables hot-plug and hot-unplug for NVMe SSDs, whether from Intel or other manufacturers. Under vSphere ESXi, several steps are necessary to avoid potential stability issues. See the information at the link [1] below.

Hot-unplug

1. Prevent devices from being re-detected during rescan:

```
esxcli storage core claiming autoclaim --enabled=false
```

2. Unmount the VMFS volumes on the device. Check [2] for details.
3. Detach the device. Check [3] for details.
4. Physically remove the device.

Hot-plug

- Physically install the device.

ESXi will automatically discover NVMe SSDs, but a manual scan may be required in some cases.

Related Information Links

[1] <https://kb.vmware.com/s/article/2151404>

[2] <https://docs.vmware.com/en/VMware-vSphere/6.5/com.vmware.vsphere.storage.doc/GUID-1B56EF97-F60E-4F21-82A7-8F2A7294604D.html>

[3] <https://docs.vmware.com/en/VMware-vSphere/6.5/com.vmware.vsphere.storage.doc/GUID-F2E75F67-740B-4406-9F0C-A2D99A698F2A.html>

Chapter 7

Troubleshooting and Support

7.1 Information Resources

Website

A great deal of information is available on the Supermicro website, <http://www.supermicro.com>.

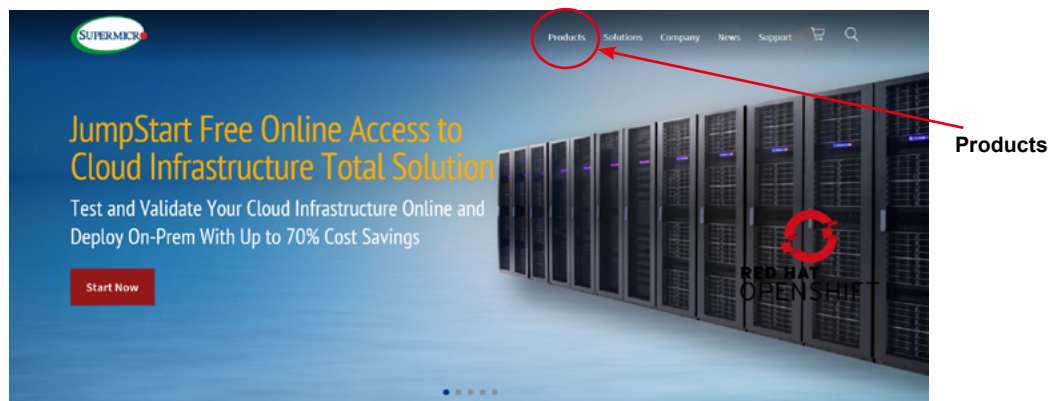

Figure 7-1. Supermicro Website

- Specifications for servers and other hardware are available by clicking on Products.
- The Support option offers downloads (manuals, BIOS/BMC, drivers, etc.), FAQs, RMA, warranty, and other service extensions.

Direct Links for the SYS-621BT-H Series System

[SYS-621BT-H Series specifications page](#)

[X13DET-B motherboard page](#) for links to the Quick Reference Guide, User Manual, validated storage drives, etc.

[SCC-P6N6SGH-B1](#)

[SCC- P2HM2G4-B1](#)

[SCC-A2NM2241G3-B1](#)

Direct Links (continued)

Direct Links for General Support and Information

[Frequently Asked Questions](#)

[Add-on card descriptions](#)

[TPM User Guide](#)

[General Memory Configuration Guide: X13](#)

[BMC User Guide](#)

[SuperDoctor5 Large Deployment Guide](#)

[For validated memory, use our Product Resources page](#)

[Product Matrices](#) page for links to tables summarizing specs for systems, motherboards, power supplies, riser cards, add-on cards, etc.

[Security Center](#) for recent security notices

[Supersmicro Phone and Addresses](#)

7.2 Baseboard Management Controller (BMC)

The system supports the Baseboard Management Controller (BMC). BMC is used to provide remote access, monitoring and management. There are several BIOS settings that are related to BMC.

For general documentation and information on BMC, please visit our website at: <https://www.supersmicro.com/en/solutions/management-software/bmc-resources>.

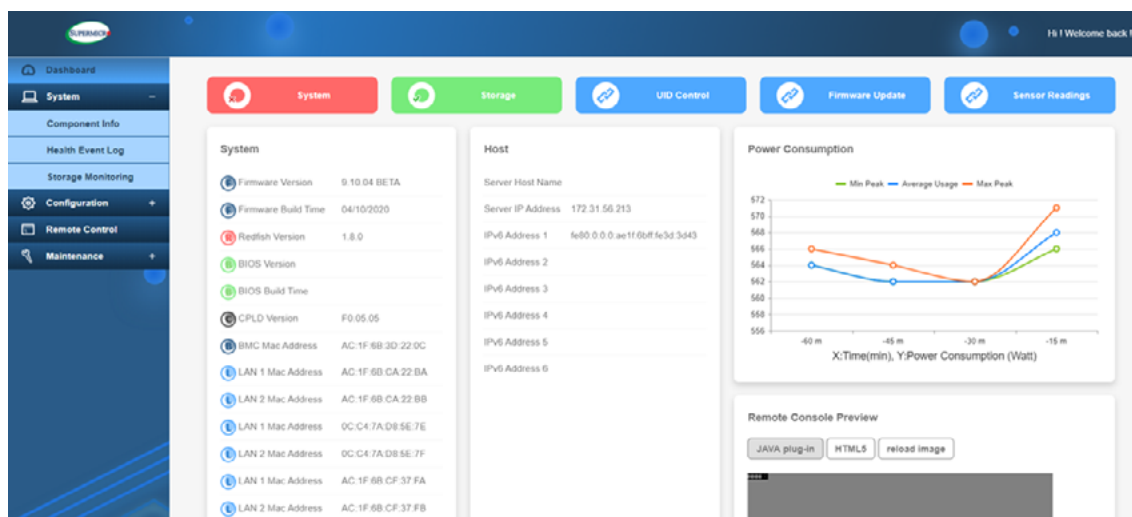

Figure 7-2. BMC Sample

7.3 Troubleshooting Procedures

Use the following procedures to troubleshoot your system. If you have followed all of the procedures below and still need assistance, refer to the [Technical Support Procedures](#) or [Returning Merchandise for Service](#) section(s) in this chapter. Always disconnect the AC power cord before adding, changing or installing any non hot-swap hardware components. If the below steps do not fix the setup configuration problem, contact your vendor for repairs.

Before Power On

1. Make sure that there are no short circuits between the motherboard and chassis.
2. Disconnect all ribbon/wire cables from the motherboard, including those for the keyboard and mouse.
3. Remove all add-on cards.
4. Install the CPU (making sure it is fully seated) and connect the front panel connectors to the motherboard.

No Power

1. Make sure that there are no short circuits between the motherboard and the chassis.
2. Make sure that the ATX power connectors are properly connected.
3. Check that the 115V/230V switch, if available, on the power supply is properly set.
4. Turn the power switch on and off to test the system, if applicable.
5. The battery on your motherboard may be old. Check to verify that it still supplies approximately 3VDC. If it does not, replace it with a new one.

No Video

1. If the power is on, but you do not have video, remove all add-on cards and cables.
2. Remove all memory modules and turn on the system (if the alarm is on, check the specs of memory modules, reset the memory, or try a different one).

System Boot Failure

If the system does not display POST (Power-On-Self-Test) or does not respond after the power is turned on, check the following:

1. Remove all components from the motherboard, especially the DIMM modules. Power on the system and check if the Power Status LED (LE6) and the BMC Heartbeat LED (UID_LED1/LEDBMC) are on, and system fans are spinning.
2. Turn on the system with only one DIMM module installed. If the system boots, check for bad DIMM modules or slots by following the Memory Errors Troubleshooting procedure in this chapter.

Memory Errors

1. Make sure that the memory modules are compatible with the system and are properly installed. See Chapter 2 for installation instructions. (For memory compatibility, refer to the "Tested Memory List" link on the motherboard's product page to see a list of supported memory.)
2. Check if different speeds of DIMMs have been installed. It is strongly recommended that you use the same RAM type and speed for all DIMM modules in the system.
3. Make sure that you are using the correct type of ECC DDR5 modules recommended by the manufacturer.
4. Check for bad DIMM modules or slots by swapping a single module among all memory slots and check the results.

Losing the System's Setup Configuration

1. Make sure that you are using a high-quality power supply. A poor-quality power supply may cause the system to lose the CMOS setup information. Refer to Chapter 1 for details on recommended power supplies.
2. The battery on your motherboard may be old. Check to verify that it still supplies approximately 3VDC. If it does not, replace it with a new one.

When the System Becomes Unstable

If the system becomes unstable during or after OS installation, check the following:

1. CPU/BIOS support: Make sure that your CPU is supported and that you have the latest BIOS installed in your system.
2. Memory support: Make sure that the memory modules are supported by testing the modules using memtest86 or a similar utility.

Note: Click on the "Tested Memory List" link on the motherboard's product page to see a list of supported memory

3. Storage drive support: Make sure that all drives work properly. Replace the bad drives with good ones.
4. System cooling: Check the system cooling to make sure that all heatsink fans and CPU/system fans, etc., work properly. Check the hardware monitoring settings in the BMC to make sure that the CPU and system temperatures are within the normal range. Also check the front panel Overheat LED and make sure that it is not on.
5. Adequate power supply: Make sure that the power supply provides adequate power to the system. Make sure that all power connectors are connected. Please refer to our website for more information on the minimum power requirements.
6. Proper software support: Make sure that the correct drivers are used.

If the system becomes unstable before or during OS installation, check the following:

1. Source of installation: Make sure that the devices used for installation are working properly, including boot devices such as CD.
2. Cable connection: Check to make sure that all cables are connected and working properly.
3. Using the minimum configuration for troubleshooting: Remove all unnecessary components (starting with add-on cards first), and use the minimum configuration (but with a CPU and a memory module installed) to identify the trouble areas. Refer to the steps listed in [Section 7.3](#) above for proper troubleshooting procedures.
4. Identifying bad components by isolating them: If necessary, remove a component in question from the chassis, and test it in isolation to make sure that it works properly. Replace a bad component with a good one.

5. Check and change one component at a time instead of changing several items at the same time. This will help isolate and identify the problem.
6. To find out if a component is good, swap this component with a new one to see if the system will work properly. If so, then the old component is bad. You can also install the component in question in another system. If the new system works, the component is good and the old system has problems.

7.4 Crash Dump Using BMC

In the event of a processor internal error (IERR) that crashes your system, you may want to provide information to support staff. You can download a crash dump of status information using BMC. The BMC manual is available at <https://www.supermicro.com/en/solutions/management-software/bmc-resources>.

Check BMC Error Log

1. Access the BMC web interface.
2. Click the **System** tab, then **Health Event Log** to verify an IERR error.

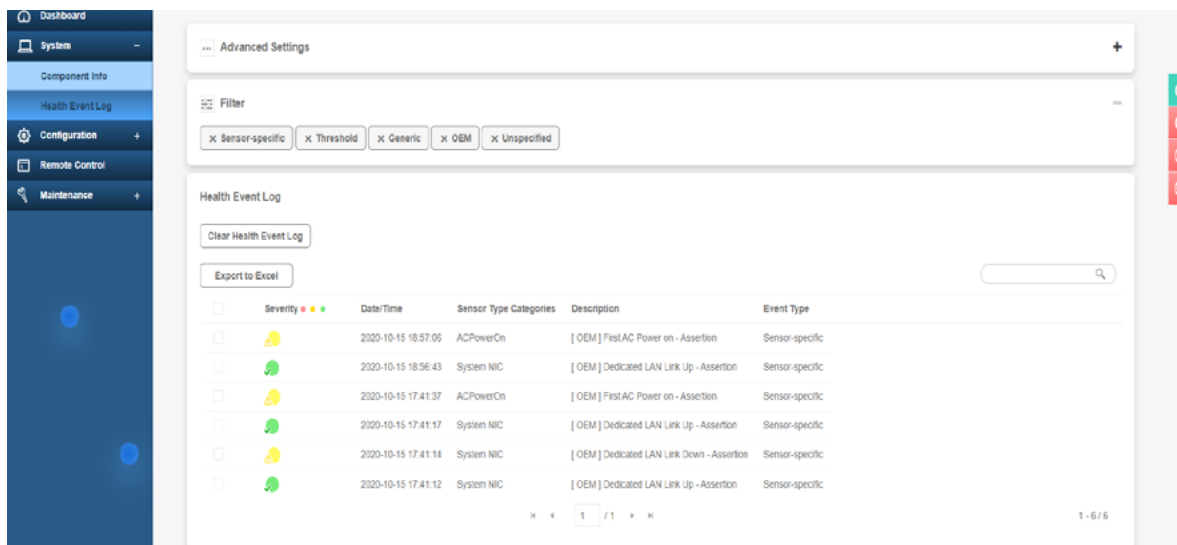

The screenshot displays the BMC Health Event Log interface. On the left is a navigation sidebar with options: Dashboard, System, Component Info, Health Event Log (selected), Configuration, Remote Control, and Maintenance. The main content area shows 'Advanced Settings' at the top, followed by a 'Filter' section with buttons for 'Sensor-specific', 'Threshold', 'Generic', 'OEM', and 'Unspecified'. Below the filter is the 'Health Event Log' section, which includes a 'Clear Health Event Log' button, an 'Export to Excel' button, and a search bar. The event log is presented as a table with the following data:

Sev	Severity	Data/Time	Sensor Type Categories	Description	Event Type
🟡	Warning	2020-10-15 18:57:05	ACPowerOn	[OEM] FirstAC Power on - Assertion	Sensor-specific
🟢	Info	2020-10-15 18:56:43	System NIC	[OEM] Dedicated LAN Link Up - Assertion	Sensor-specific
🟡	Warning	2020-10-15 17:41:37	ACPowerOn	[OEM] FirstAC Power on - Assertion	Sensor-specific
🟢	Info	2020-10-15 17:41:17	System NIC	[OEM] Dedicated LAN Link Up - Assertion	Sensor-specific
🟡	Warning	2020-10-15 17:41:14	System NIC	[OEM] Dedicated LAN Link Down - Assertion	Sensor-specific
🟢	Info	2020-10-15 17:41:12	System NIC	[OEM] Dedicated LAN Link Up - Assertion	Sensor-specific

At the bottom of the table, there are navigation controls: '1 / 1' and '1 - 6 / 6'.

Figure 7-3. BMC Event Log

In the event of an IERR, the BMC executes a crash dump. You must download the crash dump and save it.

7.5 UEFI BIOS Recovery

Important: Do not upgrade the BIOS unless your system has a BIOS-related issue. Flashing the wrong BIOS can cause irreparable damage to the system. In no event shall Supermicro be liable for direct, indirect, special, incidental, or consequential damages arising from a BIOS update. If you do update the BIOS, do not shut down or reset the system while the BIOS is updating to avoid possible boot failure.

Overview

The Unified Extensible Firmware Interface (UEFI) provides a software-based interface between the operating system and the platform firmware in the pre-boot environment. The UEFI specification supports an architecture-independent mechanism that will allow the UEFI OS loader stored in an add-on card to boot the system. The UEFI offers clean, hands-off management to a computer during system boot.

Recovering the UEFI BIOS Image

A UEFI BIOS flash chip consists of a recovery BIOS block and a main BIOS block (a main BIOS image). The recovery block contains critical BIOS codes, including memory detection and recovery codes for the user to flash a healthy BIOS image if the original main BIOS image is corrupted. When the system power is turned on, the recovery block codes execute first. Once this process is complete, the main BIOS code will continue with system initialization and the remaining POST (Power-On Self-Test) routines.

Note 1: Follow the BIOS recovery instructions below for BIOS recovery when the main BIOS block crashes.

Note 2: When the BIOS recovery block crashes, you will need to follow the procedures to make a Returned Merchandise Authorization (RMA) request. Also, you may use the Supermicro Update Manager (SUM) Out-of-Band (https://www.supermicro.com.tw/products/nfo/SMS_SUM.cfm) to reflash the BIOS.

Recovering the Main BIOS Block with a USB Device

This feature allows the user to recover the main BIOS image using a USB-attached device without additional utilities used. A USB flash or media device can be used for this purpose. However, a USB Hard Disk drive cannot be used for BIOS recovery at this time.

The file system supported by the recovery block is FAT (including FAT12, FAT16, and FAT32) which is installed on a bootable or non-bootable USB-attached device. However, the BIOS might need several minutes to locate the SUPER.ROM file if the media size becomes too large due to the huge volumes of folders and files stored in the device.

To perform UEFI BIOS recovery using a USB-attached device, follow the instructions below.

1. Using a different machine, copy the "Super.ROM" binary image file into the Root "\\" directory of a USB device or a writable CD.

Note 1: If you cannot locate the "Super.ROM" file in your drive disk, visit our website at www.supermicro.com to download the BIOS package. Extract the BIOS binary image into a USB flash device and rename it "Super.ROM" for the BIOS recovery use.

Note 2: Before recovering the main BIOS image, confirm that the "Super.ROM" binary image file you download is the same version or a close version meant for your motherboard.

2. Insert the USB device that contains the new BIOS image ("Super.ROM") into your USB drive and reset the system when the following screen appears.

3. After locating the healthy BIOS binary image, the system will enter the BIOS Recovery menu as shown below.



Note: At this point, you may decide if you want to start the BIOS recovery. If you decide to proceed with BIOS recovery, follow the procedures below.

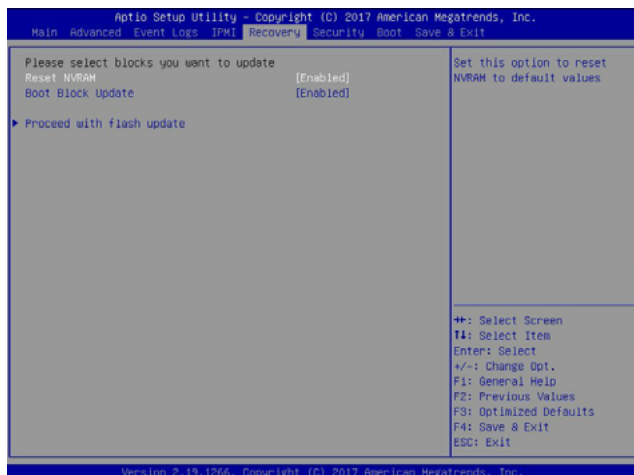

4. When the screen as shown above displays, use the arrow keys to select the item "Proceed with flash update" and press the <Enter> key. You will see the BIOS recovery progress as shown in the screen below.

Note: Do not interrupt the BIOS flashing process until it has completed.

5. After the BIOS recovery process is complete, press any key to reboot the system.

6. Using a different system, extract the BIOS package into a USB flash drive.

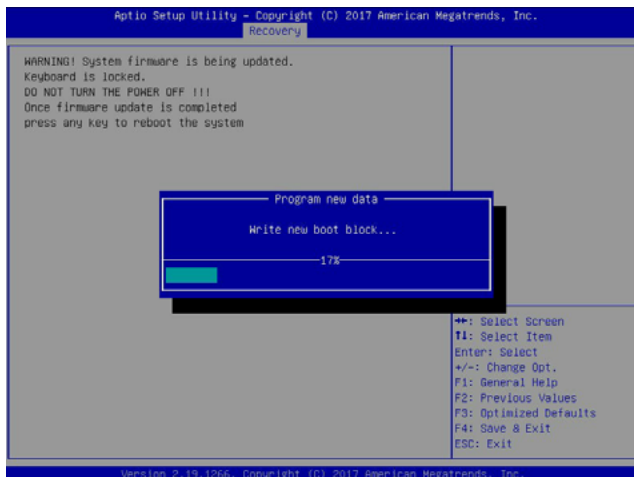

7. Press continuously during system boot to enter the BIOS Setup utility. From the top of the tool bar, select Boot to enter the submenu. From the submenu list, select Boot Option #1 as shown below. Then, set Boot Option #1 to [UEFI AP:UEFI: Built-in EFI Shell].

Press <F4> to save the settings and exit the BIOS Setup utility.

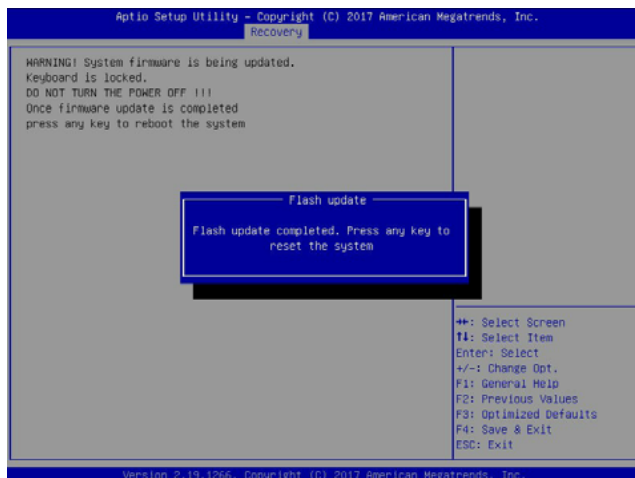

8. When the UEFI Shell prompt appears, type fs# to change the device directory path. Go to the directory that contains the BIOS package you extracted earlier from Step 6. Enter flash.nsh BIOSname.### at the prompt to start the BIOS update process.

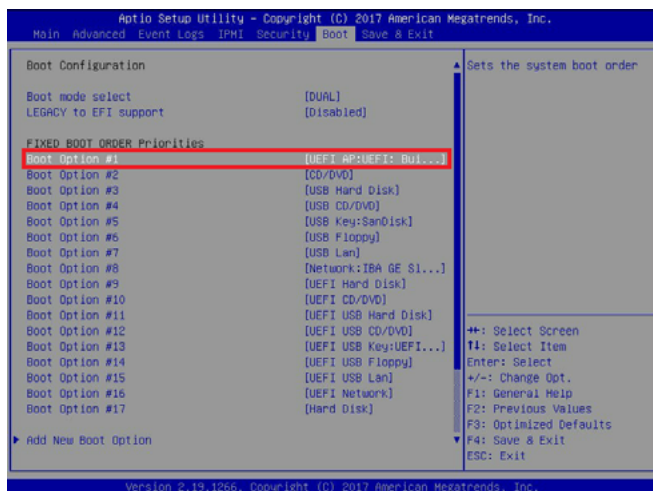

Note: Do not interrupt this process until the BIOS flashing is complete.

```

UEFI Interactive Shell v2.1
UEFI 2.50 (American Megatrends, 0x0005000C)
Mapping table
FS0: Alias(s):HD(0):GPT:BLK1:
      PciRoot(0x0)/Pci(0x14,0x0)/USB(0x11,0x0)/HD(1,MBR,0x37901072,0x000,0x1
CA5592)
      BLK0: Alias(s):
      PciRoot(0x0)/Pci(0x14,0x0)/USB(0x11,0x0)
Press F8C in 4 seconds to skip startup.nsh or any other key to continue.
Shell> f8c
FS0:\> cd VFU005
FS0:\VFU005> cd SKIPME2_03162017
FS0:\VFU005\SKIPME2_03162017> flash.nsh X115FN7_314

```

9. The screen above indicates that the BIOS update process is complete. When you see the screen above, unplug the AC power cable from the power supply, clear CMOS, and plug the AC power cable in the power supply again to power on the system.

```

Done.
[ Access CMOS Fort Ex ]
dread
Index 0x51: 0x1B
Done.
*****
* Program BIOS and ME (including FDT) regions...
*****
| AMI Firmware Update Utility v2.09.01.1D17 |
| Copyright (C)2017 American Megatrends Inc. All Rights Reserved. |
-----
CPUID = 50652
Reading flash ..... done
- ME Data Size checking ..... ok
- FFS checksums ..... ok
- Check ROM layout ..... ok
Erasing Boot Block ..... done
Updating Boot Block ..... done
Verifying Boot Block ..... done
Erasing Main Block ..... 0x0132000 (OK)

```

10. Press continuously to enter the BIOS Setup utility.

```

Verifying MCB Block ..... done
- Update success for F8C
- Successful update Recovery Loader to OPRx!!
- Successful update #FSB!!
- Successful update #FMB!!
- Successful update #FS, IVB1 and IVB2!!
- Successful update FLOG and UTDK!!
- ME Entire image update success !!
WARNING: System must power-off to have the changes take effect!
Moving FS0:\VFU005\SKIPME2_03162017\fdt\64.efi -> FS0:\VFU005\SKIPME2_03162017\F
dt.smc
- [ok]
Moving FS0:\VFU005\SKIPME2_03162017\ufef\64.efi -> FS0:\VFU005\SKIPME2_0316201
7\ufef.smc
- [ok]
*****
* Please ignore this 'Shell: Cannot read from file - Device Error'
* warning message due to it does not impact flashing process.
*****
Deleting *
Delete successful.
FS0:\>

```

11. Press <F3> to load the default settings.

12. After loading the default settings, press <F4> to save the settings and exit the BIOS Setup utility.

7.6 Where to Get Replacement Components

If you need replacement parts for your system, to ensure the highest level of professional service and technical support, purchase exclusively from our Supermicro Authorized Distributors/System Integrators/Resellers. A list can be found at: <http://www.supermicro.com/>. Click the "Where to Buy" tab.

7.7 Reporting an Issue

Technical Support Procedures

Before contacting Technical Support, please take the following steps. If your system was purchased through a distributor or reseller, please contact them for troubleshooting services. They have the best knowledge of your specific system configuration.

1. Please review the [Troubleshooting Procedures](#) in this manual and [Frequently Asked Questions](#) on our website before contacting Technical Support.
2. BIOS upgrades can be downloaded from our website. Note: Not all BIOS can be flashed depending on the modifications to the boot block code.
3. If you still cannot resolve the problem, include the following information when contacting us for technical support:
 - System, motherboard, and chassis model numbers and PCB revision number
 - BIOS release date/version (this can be seen on the initial display when your system first boots up)
 - System configuration

An example of a Technical Support form is posted on our [website](#). Distributors: For immediate assistance, please have your account number ready when contacting our technical support department by email.

Returning Merchandise for Service

A receipt or copy of your invoice marked with the date of purchase is required before any warranty service will be rendered. You can obtain service by calling your vendor for a Returned Merchandise Authorization (RMA) number. When returning to the manufacturer, the RMA number should be prominently displayed on the outside of the shipping carton, and mailed prepaid or hand-carried. Shipping and handling charges will be applied for all orders that must be mailed when service is complete.

For faster service, RMA authorizations may be requested online (<http://www.supermicro.com/support/rma/>).

Whenever possible, repack the chassis in the original Supermicro carton, using the original packaging material. If these are no longer available, be sure to pack the chassis securely, using packaging material to surround the chassis so that it does not shift within the carton and become damaged during shipping.

This warranty only covers normal consumer use and does not cover damages incurred in shipping or from failure due to the alteration, misuse, abuse or improper maintenance of products.

During the warranty period, contact your distributor first for any product problems.

Vendor Support Filing System

For issues related to Intel, use the Intel IPS filing system:

<https://www.intel.com/content/www/us/en/design/support/ips/training/welcome.html>

For issues related to Red Hat Enterprise Linux, since it is a subscription based OS, contact your account representative.

7.8 Feedback

Supermicro values your feedback as we strive to improve our customer experience in all facets of our business. Please email us at techwriterteam@supermicro.com to provide feedback on our manuals.

7.9 Contacting Supermicro

Headquarters

Address: Super Micro Computer, Inc.
980 Rock Ave.
San Jose, CA 95131 U.S.A.

Tel: +1 (408) 503-8000

Fax: +1 (408) 503-8008

Email: marketing@supermicro.com (General Information)
Sales-USA@supermicro.com (Sales Inquiries)
Government_Sales-USA@supermicro.com (Gov. Sales Inquiries)
support@supermicro.com (Technical Support)
RMA@supermicro.com (RMA Support)
Webmaster@supermicro.com (Webmaster)

Website: www.supermicro.com

Europe

Address: Super Micro Computer B.V.
Het Sterrenbeeld 28, 5215 ML
's-Hertogenbosch, The Netherlands

Tel: +31 (0) 73-6400390

Fax: +31 (0) 73-6416525

Email: Sales_Europe@supermicro.com (Sales Inquiries)
Support_Europe@supermicro.com (Technical Support)
RMA_Europe@supermicro.com (RMA Support)

Website: www.supermicro.nl

Asia-Pacific

Address: Super Micro Computer, Inc.
3F, No. 150, Jian 1st Rd.
Zhonghe Dist., New Taipei City 235
Taiwan (R.O.C)

Tel: +886-(2) 8226-3990

Fax: +886-(2) 8226-3992

Email: Sales-Asia@supermicro.com.tw (Sales Inquiries)
Support@supermicro.com.tw (Technical Support)
RMA@supermicro.com.tw (RMA Support)

Website: www.supermicro.com.tw

Appendix A

Standardized Warning Statements for AC Systems

About Standardized Warning Statements

The following statements are industry standard warnings, provided to warn the user of situations which have the potential for bodily injury. Should you have questions or experience difficulty, contact Supermicro's Technical Support department for assistance. Only certified technicians should attempt to install or configure components.

Read this appendix in its entirety before installing or configuring components in the Supermicro chassis.

These warnings may also be found on our website at http://www.supermicro.com/about/policies/safety_information.cfm.

Warning Definition



Warning! This warning symbol means danger. You are in a situation that could cause bodily injury. Before you work on any equipment, be aware of the hazards involved with electrical circuitry and be familiar with standard practices for preventing accidents.

警告の定義

この警告サインは危険を意味します。

人身事故につながる可能性がありますので、いずれの機器でも動作させる前に、電気回路に含まれる危険性に注意して、標準的な事故防止策に精通して下さい。

此警告符号代表危險。

您正处于可能受到严重伤害的工作环境中。在您使用设备开始工作之前，必须充分意识到触电的危险，并熟练掌握防止事故发生的标准工作程序。请根据每项警告结尾的声明号码找到此设备的安全性警告说明的翻译文本。

此警告符號代表危險。

您正處於可能身體可能會受損傷的工作環境中。在您使用任何設備之前，請注意觸電的危險，並且要熟悉預防事故發生的標準工作程序。請依照每一注意事項後的號碼找到相關的翻譯說明內容。

Warnung

WICHTIGE SICHERHEITSHINWEISE

Dieses Warnsymbol bedeutet Gefahr. Sie befinden sich in einer Situation, die zu Verletzungen führen kann. Machen Sie sich vor der Arbeit mit Geräten mit den Gefahren elektrischer Schaltungen und den üblichen Verfahren zur Vorbeugung vor Unfällen vertraut. Suchen Sie mit der am Ende jeder Warnung angegebenen Anweisungsnummer nach der jeweiligen Übersetzung in den übersetzten Sicherheitshinweisen, die zusammen mit diesem Gerät ausgeliefert wurden.

BEWAHREN SIE DIESE HINWEISE GUT AUF.

INSTRUCCIONES IMPORTANTES DE SEGURIDAD

Este símbolo de aviso indica peligro. Existe riesgo para su integridad física. Antes de manipular cualquier equipo, considere los riesgos de la corriente eléctrica y familiarícese con los procedimientos estándar de prevención de accidentes. Al final de cada advertencia encontrará el número que le ayudará a encontrar el texto traducido en el apartado de traducciones que acompaña a este dispositivo.

GUARDE ESTAS INSTRUCCIONES.

IMPORTANTES INFORMATIONS DE SÉCURITÉ

Ce symbole d'avertissement indique un danger. Vous vous trouvez dans une situation pouvant entraîner des blessures ou des dommages corporels. Avant de travailler sur un équipement, soyez conscient des dangers liés aux circuits électriques et familiarisez-vous avec les procédures couramment utilisées pour éviter les accidents. Pour prendre connaissance des traductions des avertissements figurant dans les consignes de sécurité traduites qui accompagnent cet appareil, référez-vous au numéro de l'instruction situé à la fin de chaque avertissement.

CONSERVEZ CES INFORMATIONS.

תקנון הזהרות אזהרה

הזהרות הבאות הן אזהרות על פי תקני התעשייה, על מנת להזהיר את המשתמש מפני חבלה פיזית אפשרית. במידה ויש שאלות או היתקלות בבעיה כלשהי, יש ליצור קשר עם מחלקת תמיכה טכנית של סופרמיקרו. טכנאים מוסמכים בלבד רשאים להתקין או להגדיר את הרכיבים. יש לקרוא את הנספח במלואו לפני התקנת או הגדרת הרכיבים במארזי סופרמיקרו.

اَكْ ف حالة وُكِي اَي تتسبب ف اصابة جسدهُ هذا الزهز عُ خطر! تحذُرُ .
 قبل اَي تعول على اَي هعدات، كي على علن بالوخاطز ال اُجوة عي الذوائر
 الكهزبائِة
 وكي على دراةُ بالووارسات النقاائِة لو عُ وقع اَي حادث
 استخدم رقن الب اِي الو صُص ف هاةُ كل تحذُرُ للعشر تزجوتها

안전을 위한 주의사항

경고!

이 경고 기호는 위험이 있음을 알려 줍니다. 작업자의 신체에 부상을 야기 할 수 있는 상태에 있게 됩니다. 모든 장비에 대한 작업을 수행하기 전에 전기회로와 관련된 위험요소들을 확인하시고 사전에 사고를 방지할 수 있도록 표준 작업절차를 준수해 주시기 바랍니다.

해당 번역문을 찾기 위해 각 경고의 마지막 부분에 제공된 경고문 번호를 참조하십시오

BELANGRIJKE VEILIGHEIDSINSTRUCTIES

Dit waarschuwings symbool betekent gevaar. U verkeert in een situatie die lichamelijk letsel kan veroorzaken. Voordat u aan enige apparatuur gaat werken, dient u zich bewust te zijn van de bij een elektrische installatie betrokken risico's en dient u op de hoogte te zijn van de standaard procedures om ongelukken te voorkomen. Gebruik de nummers aan het eind van elke waarschuwing om deze te herleiden naar de desbetreffende locatie.

BEWAAR DEZE INSTRUCTIES

Installation Instructions



Warning! Read the installation instructions before connecting the system to the power source.

設置手順書

システムを電源に接続する前に、設置手順書をお読み下さい。

警告

将此系统连接电源前,请先阅读安装说明。

警告

將系統與電源連接前，請先閱讀安裝說明。

Warnung

Vor dem Anschließen des Systems an die Stromquelle die Installationsanweisungen lesen.

¡Advertencia!

Lea las instrucciones de instalación antes de conectar el sistema a la red de alimentación.

Attention

Avant de brancher le système sur la source d'alimentation, consulter les directives d'installation.

יש לקרוא את הוראות התקנה לפני חיבור המערכת למקור מתח.

اقرأ إرشادات التركيب قبل توصيل النظام إلى مصدر للطاقة

시스템을 전원에 연결하기 전에 설치 안내를 읽어주십시오.

Waarschuwing

Raadpleeg de installatie-instructies voordat u het systeem op de voedingsbron aansluit.

Circuit Breaker

Warning! This product relies on the building's installation for short-circuit (overcurrent) protection. Ensure that the protective device is rated not greater than: 250 V, 20 A.

サーキット・ブレーカー

この製品は、短絡(過電流)保護装置がある建物での設置を前提としています。

保護装置の定格が250 V、20 Aを超えないことを確認下さい。

警告

此产品的短路(过载电流)保护由建筑物的供电系统提供,确保短路保护设备的额定电流不大于250V,20A。

警告

此產品的短路(過載電流)保護由建築物的供電系統提供,確保短路保護設備的額定電流不大於250V,20A。

Warnung

Dieses Produkt ist darauf angewiesen, dass im Gebäude ein Kurzschluss- bzw. Überstromschutz installiert ist. Stellen Sie sicher, dass der Nennwert der Schutzvorrichtung nicht mehr als: 250 V, 20 A beträgt.

¡Advertencia!

Este equipo utiliza el sistema de protección contra cortocircuitos (o sobrecorrientes) del edificio. Asegúrese de que el dispositivo de protección no sea superior a: 250 V, 20 A.

Attention

Pour ce qui est de la protection contre les courts-circuits (surtension), ce produit dépend de l'installation électrique du local. Vérifiez que le courant nominal du dispositif de protection n'est pas supérieur à :250 V, 20 A.

מוצר זה מסתמך על הגנה המותקנת במבנים למניעת קצר חשמלי. יש לוודא כי המכשיר המגן מפני הקצר החשמלי הוא לא יותר מ-20A, 250V.

هذا المنتج يعتمد على معدات الحماية من الدوائر القصيرة التي تم تثبيتها في المبنى
تأكد من أن تقييم الجهاز الوقائي ليس أكثر من : 20A, 250V

경고!

이 제품은 전원의 단락(과전류)방지에 대해서 전적으로 건물의 관련 설비에 의존합니다. 보호장치의 정격이 반드시 250V(볼트), 20A(암페어)를 초과하지 않도록 해야 합니다.

Waarschuwing

Dit product is afhankelijk van de kortsluitbeveiliging (overspanning) van uw elektrische installatie. Controleer of het beveiligde apparaat niet groter gedimensioneerd is dan 250V, 20A.

Power Disconnection Warning



Warning! The system must be disconnected from all sources of power and the power cord removed from the power supply module(s) before accessing the chassis interior to install or remove system components (except for hot-swap components).



電源切断の警告

システムコンポーネントの取り付けまたは取り外しのために、シャーシ内部にアクセスするには、システムの電源はすべてのソースから切断され、電源コードは電源モジュールから取り外す必要があります。

警告

在你打开机箱并安装或移除内部器件前,必须将系统完全断电,并移除电源线。

警告

在您打開機殼安裝或移除內部元件前，必須將系統完全斷電，並移除電源線。

Warnung

Das System muss von allen Quellen der Energie und vom Netzanschlusskabel getrennt sein, das von den Spg.Versorgungsteilmodulen entfernt wird, bevor es auf den Chassisinnenraum zurückgreift, um Systemsbestandteile anzubringen oder zu entfernen.

¡Advertencia!

El sistema debe ser disconnected de todas las fuentes de energía y del cable eléctrico quitado de los módulos de fuente de alimentación antes de tener acceso el interior del chasis para instalar o para quitar componentes de sistema.

Attention

Le système doit être débranché de toutes les sources de puissance ainsi que de son cordon d'alimentation secteur avant d'accéder à l'intérieur du chassis pour installer ou enlever des composants de système.

אזהרה מפני ניתוק חשמלי

אזהרה!

יש לנתק את המערכת מכל מקורות החשמל ויש להסיר את כבל החשמלי מהספק לפני גישה לחלק הפנימי של המארז לצורך התקנת או הסרת רכיבים.

يجب فصل انظاؤ من جميع مصادر انطاقت وإزانت سهك انكهرباء من وحدة امداد انطاقت قيم

انصل إلى امناطق انداخييت نههيكم نشييح أو إزانت مكناث الجهاز

경고!

시스템에 부품들을 장착하거나 제거하기 위해서는 새시 내부에 접근하기 전에 반드시 전원 공급장치로부터 연결되어있는 모든 전원과 전기코드를 분리해주어야 합니다.

Waarschuwing

Voordat u toegang neemt tot het binnenwerk van de behuizing voor het installeren of verwijderen van systeem onderdelen, dient u alle spanningsbronnen en alle stroomkabels aangesloten op de voeding(en) van de behuizing te verwijderen

Equipment Installation



Warning! Only authorized personnel and qualified service persons should be allowed to install, replace, or service this equipment.

機器の設置

トレーニングを受け認定された人だけがこの装置の設置、交換、またはサービスを許可されています。

警告

只有经过培训且具有资格的人员才能进行此设备的安装、更换和维修。

警告

只有經過受訓且具資格人員才可安裝、更換與維修此設備。

Warnung

Nur autorisiertes Personal und qualifizierte Servicetechniker dürfen dieses Gerät installieren, austauschen oder warten..

¡Advertencia!

Sólo el personal autorizado y el personal de servicio calificado deben poder instalar, reemplazar o dar servicio a este equipo.

Attention

Seul le personnel autorisé et le personnel de maintenance qualifié doivent être autorisés à installer, remplacer ou entretenir cet équipement..

אזהרה!

יש לאפשר רק צוות מורשה ואנשי שירות מוסמכים להתקין, להחליף או לטפל בציוד זה.

ينبغي السماح فقط للموظفين المعتمدين وأفراد الخدمة المؤهلين بتركيب هذا الجهاز أو استبداله أو صيانته.

경고!

승인된 직원과 자격을 갖춘 서비스 담당자만이 이 장비를 설치, 교체 또는 서비스할 수 있습니다.

Waarschuwing

Alleen geautoriseerd personeel en gekwalificeerd onderhoudspersoneel mag deze apparatuur installeren, vervangen of onderhouden..

Rack Stability Hazard

Warning! Stability hazard. The rack may tip over causing serious personal injury. Before extending the rack to the installation position, read the installation instructions.

ファンの警告

安定性に危険があります。ラックが転倒して、重大な人身事故を引き起こす可能性があります。ラックを設置位置まで伸ばす前に、設置手順をお読みください。設置位置にあるスライド レールに取り付けられた機器に負荷をかけないでください。スライド レールに取り付けられた機器を設置位置に放置しないでください。

警告

稳定性危険。机架可能会翻倒，造成严重的人身伤害。在将机架延伸到安装位置之前，请阅读安装说明。请勿在安装位置对滑轨安装的设备施加任何负载。请勿将滑轨安装的设备留在安装位置。

警告

穩定性危險。機架可能會翻倒，造成嚴重的人身傷害。將機架延伸至安裝位置前，請先閱讀安裝說明。請勿在安裝位置的滑軌安裝設備上放置任何負載。請勿將滑軌安裝設備留在安裝位置。

Warnung

Gefahr der Instabilität. Das Rack kann umkippen und schwere Verletzungen verursachen. Lesen Sie die Installationsanweisungen, bevor Sie das Rack in die Einbauposition ausfahren. Belasten Sie die auf den Gleitschienen montierten Geräte nicht in der Einbauposition. Lassen Sie die auf den Gleitschienen montierten Geräte nicht in der Einbauposition.

¡Advertencia!

Peligro de inestabilidad. El rack podría volcarse y causar lesiones personales graves. Antes de extender el rack a la posición de instalación, lea las instrucciones de instalación. No coloque ninguna carga sobre el equipo montado sobre rieles deslizantes en la posición de instalación. No deje el equipo montado sobre rieles deslizantes en la posición de instalación. Sólo el personal autorizado y el personal de servicio calificado deben poder instalar, reemplazar o dar servicio a este equipo.

Avertissement!

Danger d'instabilité. Le rack peut basculer et provoquer des blessures corporelles graves. Avant d'étendre le rack en position d'installation, lire les instructions d'installation. Ne pas charger l'équipement monté sur rail de glissière en position d'installation. Ne pas laisser l'équipement monté sur rail de glissière en position d'installation.

אזהרה!

סכנת חוסר יציבות

המתלה עלול להתהפך ולגרום לפציעה חמורה

לפני הארכת המתלה למצב ההתקנה, קרא את הוראות ההתקנה

אין להעמיס כל עומס על הציוד המותקן על מסילת ההחלקה במצב ההתקנה

אל תשאיר את הציוד המותקן על מסילת ההחלקה במצב ההתקנה

تحذير. خطر عدم الاستقرار. قد ينقلب الرف مسبباً إصابات جسدية خطيرة. قبل تمديد الرف إلى موضع التركيب، اقرأ تعليمات التركيب. لا تضع أي حمولة على الجهاز المثبت على سكة الانزلاق في موضع التركيب. لا تترك الجهاز المثبت على سكة الانزلاق في موضع التركيب.

경고!

안정성 위험. 랙이 넘어져 심각한 개인 부상을 입을 수 있습니다. 랙을 설치 위치까지 확장하기 전에 설치 지침을 읽으십시오. 설치 위치에서 슬라이드 레일 장착 장비에 하중을 가하지 마십시오. 슬라이드 레일 장착 장비를 설치 위치에 두지 마십시오.

Waarschuwing

Gevaar voor instabiliteit. Het rek kan kantelen en ernstig persoonlijk letsel veroorzaken. Lees de installatie-instructies voordat u het rek uitschuift naar de installatiepositie. Plaats geen last op de op de glijrail gemonteerde apparatuur in de installatiepositie. Laat de op de glijrail gemonteerde apparatuur niet in de installatiepositie staan.

Restricted Area



Warning! This unit is intended for installation in restricted access areas. A restricted access area can be accessed only through the use of a special tool, lock and key, or other means of security. (This warning does not apply to workstations).

アクセス制限区域

このユニットは、アクセス制限区域に設置されることを想定しています。

アクセス制限区域は、特別なツール、鍵と錠前、その他のセキュリティの手段を用いてのみ出入りが可能です。

警告

此部件应安装在限制进出的场所。限制进出的场所指只能通过使用特殊工具、锁和钥匙或其它安全手段进出的场所。

警告

此装置仅限安装於進出管制區域。進出管制區域係指僅能以特殊工具、鎖頭及鑰匙或其他安全方式才能進入的區域。

Warnung

Diese Einheit ist zur Installation in Bereichen mit beschränktem Zutritt vorgesehen. Der Zutritt zu derartigen Bereichen ist nur mit einem Spezialwerkzeug, Schloss und Schlüssel oder einer sonstigen Sicherheitsvorkehrung möglich.

¡Advertencia!

Esta unidad ha sido diseñada para instalación en áreas de acceso restringido. Sólo puede obtenerse acceso a una de estas áreas mediante la utilización de una herramienta especial, cerradura con llave u otro medio de seguridad.

Attention

Cet appareil doit être installée dans des zones d'accès réservés. L'accès à une zone d'accès réservé n'est possible qu'en utilisant un outil spécial, un mécanisme de verrouillage et une clé, ou tout autre moyen de sécurité.

אזור עם גישה מוגבלת

אזהרה!

יש להתקין את היחידה באזורים שיש בהם הגבלת גישה. הגישה ניתנת בעזרת 'כלי אבטחה בלבד' (מפתח, מנעול וכד.).

تخصيص هذه انحدة نترك بُها ف مناطق محظورة تم .
ممكن انصلل إن منطقت محظورة فقط من خلال استخذاو أداة خاصت
أو أ وس هُت أخري نلالأمما قفم ومفتاح

경고!

이 장치는 접근이 제한된 구역에 설치하도록 되어있습니다. 특수도구, 잠금 장치 및 키, 또는 기타 보안 수단을 통해서만 접근 제한 구역에 들어갈 수 있습니다.

Waarschuwing

Dit apparaat is bedoeld voor installatie in gebieden met een beperkte toegang. Toegang tot dergelijke gebieden kunnen alleen verkregen worden door gebruik te maken van speciaal gereedschap, slot en sleutel of andere veiligheidsmaatregelen.

Battery Handling



CAUTION: There is risk of explosion if the battery is replaced by an incorrect type. Replace the battery only with the same or equivalent type recommended by the manufacturer. Dispose of used batteries according to the manufacturer's instructions

電池の取り扱い

バッテリーを間違ったタイプに交換すると爆発の危険があります。交換する電池はメーカーが推奨する型、または同等のものを使用下さい。使用済電池は製造元の指示に従って処分して下さい。

警告

如果更换的电池类型不正确，则存在爆炸危险。请只使用同类电池或制造商推荐的功能相当的电池更换原有电池。请按制造商的说明处理废旧电池。

警告

如果更換的電池類型不正確，則有爆炸危險。請使用製造商建議之相同或功能相當的電池更換原有電池。請按照製造商的說明指示處理廢棄舊電池。

WARNUNG

Es besteht Explosionsgefahr, wenn die Batterie durch einen falschen Typ ersetzt wird. Ersetzen Sie die Batterie nur durch den gleichen oder vom Hersteller empfohlenen Batterietyp. Entsorgen Sie die benutzten Batterien nach den Anweisungen des Herstellers.

ATTENTION

Il existe un risque d'explosion si la batterie est remplacée par un type incorrect. Ne la remplacer que par une pile de type semblable ou équivalent, recommandée par le fabricant. Jeter les piles usagées conformément aux instructions du fabricant.

ADVERTENCIA

Existe riesgo de explosión si la batería se reemplaza por un tipo incorrecto. Reemplazar la batería exclusivamente con el mismo tipo o el equivalente recomendado por el fabricante. Desechar las baterías gastadas según las instrucciones del fabricante.

אזהרה!

קיימת סכנת פיצוץ אם הסוללה תוחלף בסוג שגוי. יש להחליף את הסוללה בסוג התואם מחברת יצרן מומלצת. סילוק הסוללות המשומשות יש לבצע לפי הוראות היצרן.

هناك خطر الانفجار إذا تم استبدال البطارية بنوع غير صحيح.
 اسحبذال البطارية
 فقط بنفس النوع أو ما يعادلها مما أوصت به الشركة المصنعة
 جخلص من البطاريات المسحعملة وفقا لعمليات الشركة الصانعة

경고!

배터리를 잘못된 종류로 교체하면 폭발의 위험이 있습니다. 기존 배터리와 동일하거나 제조사에서 권장하는 동등한 종류의 배터리로만 교체해야 합니다. 제조사의 안내에 따라 사용된 배터리를 처리하여 주십시오.

WAARSCHUWING

Er bestaat explosiegevaar als de batterij wordt vervangen door een verkeerd type. Vervang de batterij slechts met hetzelfde of een equivalent type die door de fabrikant aanbevolen wordt. Gebruikte batterijen dienen overeenkomstig fabrieksvoorschriften afgevoerd te worden.

Redundant Power Supplies



Warning! This unit might have more than one power supply connection. All connections must be removed to de-energize the unit.

冗長電源装置

このユニットは複数の電源装置が接続されている場合があります。

ユニットの電源を切るためには、すべての接続を取り外さなければなりません。

警告

此部件连接的电源可能不止一个，必须将所有电源断开才能停止给该部件供电。

警告

此装置连接的电源可能不只一个，必须切断所有电源才能停止对该装置的供电。

Warnung

Dieses Gerät kann mehr als eine Stromzufuhr haben. Um sicherzustellen, dass der Einheit kein Strom zugeführt wird, müssen alle Verbindungen entfernt werden.

¡Advertencia!

Puede que esta unidad tenga más de una conexión para fuentes de alimentación. Para cortar por completo el suministro de energía, deben desconectarse todas las conexiones.

Attention

Cette unité peut avoir plus d'une connexion d'alimentation. Pour supprimer toute tension et tout courant électrique de l'unité, toutes les connexions d'alimentation doivent être débranchées.

אם קיים יותר מספק אחד

אזהרה!

ליחידה יש יותר מחיבור אחד של ספק. יש להסיר את כל החיבורים על מנת לרוקן את היחידה.

قد يكون لهذا الجهاز عدة اتصالات بوحدات امداد الطاقة .

يجب إزالة كافة الاتصالات لعسل الوحدة عن الكهرباء

경고!

이 장치에는 한 개 이상의 전원 공급 단자가 연결되어 있을 수 있습니다. 이 장치에 전원을 차단하기 위해서는 모든 연결 단자를 제거해야만 합니다.

Waarschuwing

Deze eenheid kan meer dan één stroomtoevoeraansluiting bevatten. Alle aansluitingen dienen verwijderd te worden om het apparaat stroomloos te maken.

Backplane Voltage



Warning! Hazardous voltage or energy is present on the backplane when the system is operating. Use caution when servicing.

バックプレーンの電圧

システムの稼働中は危険な電圧または電力が、バックプレーン上にかかっています。

修理する際には注意ください。

警告

当系统正在进行时，背板上有很危险的电压或能量，进行维修时务必小心。

警告

當系統正在進行時，背板上有危險的電壓或能量，進行維修時務必小心。

Warnung

Wenn das System in Betrieb ist, treten auf der Rückwandplatine gefährliche Spannungen oder Energien auf. Vorsicht bei der Wartung.

¡Advertencia!

Cuando el sistema está en funcionamiento, el voltaje del plano trasero es peligroso. Tenga cuidado cuando lo revise.

Attention

Lorsque le système est en fonctionnement, des tensions électriques circulent sur le fond de panier. Prendre des précautions lors de la maintenance.

מתח בפנל האחורי

אזהרה!

קיימת סכנת מתח בפנל האחורי בזמן תפעול המערכת. יש להיזהר במהלך העבודה.

هناك خطر من التيار الكهربائي أو الطاقة المتجددة على اللوحة
عندما يكون النظام يعمل كه حذرا عند خدمة هذا الجهاز

경고!

시스템이 동작 중일 때 후면판 (Backplane)에는 위험한 전압이나 에너지가 발생 합니다.
서비스 작업 시 주의하십시오.

Waarschuwing

Een gevaarlijke spanning of energie is aanwezig op de backplane wanneer het systeem in gebruik is. Voorzichtigheid is geboden tijdens het onderhoud.

Comply with Local and National Electrical Codes



Warning! Installation of the equipment must comply with local and national electrical codes.

地方および国の電気規格に準拠

機器の取り付けはその地方および国の電気規格に準拠する必要があります。

警告

设备安装必须符合本地与本国电气法规。

警告

設備安裝必須符合本地與本國電氣法規。

Warnung

Die Installation der Geräte muss den Sicherheitsstandards entsprechen.

¡Advertencia!

La instalación del equipo debe cumplir con las normas de electricidad locales y nacionales.

Attention

L'équipement doit être installé conformément aux normes électriques nationales et locales.

תיאום חוקי החשמל הארצי
אזהרה!
התקנת הציוד חייבת להיות תואמת לחוקי החשמל המקומיים והארציים.

تركيب المعدات الكهربائية يجب أن يمتثل للقوايه المحلية والبطية المتعلقة
بالكهرباء

경고!

현 지역 및 국가의 전기 규정에 따라 장비를 설치해야 합니다.

Waarschuwing

Bij installatie van de apparatuur moet worden voldaan aan de lokale en nationale elektriciteitsvoorschriften.

Product Disposal



Warning! Ultimate disposal of this product should be handled according to all national laws and regulations.

製品の廃棄

この製品を廃棄処分する場合、国の関係する全ての法律・条例に従い処理する必要があります。

警告

本产品的废弃处理应根据所有国家的法律和规章进行。

警告

本產品的廢棄處理應根據所有國家的法律和規章進行。

Warnung

Die Entsorgung dieses Produkts sollte gemäß allen Bestimmungen und Gesetzen des Landes erfolgen.

¡Advertencia!

Al deshacerse por completo de este producto debe seguir todas las leyes y reglamentos nacionales.

Attention

La mise au rebut ou le recyclage de ce produit sont généralement soumis à des lois et/ou directives de respect de l'environnement. Renseignez-vous auprès de l'organisme compétent.

סילוק המוצר

אזהרה!

סילוק סופי של מוצר זה חייב להיות בהתאם להנחיות וחוקי המדינה.

التخلص النهائي من هذا المنتج ينبغي التعامل معه وفقا لجميع القوانين واللوائح الوطنية عند

경고!

이 제품은 해당 국가의 관련 법규 및 규정에 따라 폐기되어야 합니다.

Waarschuwing

De uiteindelijke verwijdering van dit product dient te geschieden in overeenstemming met alle nationale wetten en reglementen.

Fan Warning



Warning! Hazardous moving parts. Keep away from moving fan blades. The fans might still be turning when you remove the fan assembly from the chassis. Keep fingers, screwdrivers, and other objects away from the openings in the fan assembly's housing.

ファンの警告

警告!回転部品に注意。運転中は回転部(羽根)に触れないでください。シャーシから冷却ファン装置を取り外した際、ファンがまだ回転している可能性があります。ファンの開口部に、指、ドライバー、およびその他のものを近づけないで下さい。

警告!

警告! 危险的可移动性零件。请务必与转动的风扇叶片保持距离。当您从机架移除风扇装置，风扇可能仍在转动。小心不要将手指、螺丝起子和其他物品太靠近风扇

警告

危险的可移动性零件。请务必与转动的风扇叶片保持距离。当您从机架移除风扇装置，风扇可能仍在转动。小心不要将手指、螺丝起子和其他物品太靠近风扇。

Warnung

Gefährlich Bewegende Teile. Von den bewegenden Lüfterblätter fern halten. Die Lüfter drehen sich u. U. noch, wenn die Lüfterbaugruppe aus dem Chassis genommen wird. Halten Sie Finger, Schraubendreher und andere Gegenstände von den Öffnungen des Lüftergehäuses entfernt.

¡Advertencia!

Riesgo de piezas móviles. Mantener alejado de las aspas del ventilador. Los ventiladores podran dar vuelta cuando usted quite el montaje del ventilador del chasis. Mantenga los dedos, los destornilladores y todos los objetos lejos de las aberturas del ventilador

Attention

Pieces mobiles dangereuses. Se tenir a l'écart des lames du ventilateur Il est possible que les ventilateurs soient toujours en rotation lorsque vous retirerez le bloc ventilateur du châssis. Prenez garde à ce que doigts, tournevis et autres objets soient éloignés du logement du bloc ventilateur.

אזהרה!

חלקים נעים מסוכנים. התרחק מלהבי המאוורר בפעולה כאשר מסירים את חלקי המאוורר מהמארז, יתכן והמאווררים עדיין עובדים. יש להרחיק למרחק בטוח את האצבעות וכלי עבודה שונים מהפתחים בתוך המאוורר

تحذير! أجزاء متحركة خطيرة. ابتعد عن شفرات المروحة المتحركة. من الممكن أن المراوح لا تزال تدور عند إزالة كتلة المروحة من الهيكل يجب إبقاء الأصابع ومفكات البراغي وغيرها من الأشياء بعيدا عن الفتحات في كتلة المروحة.

경고!

움직이는 위험한 부품. 회전하는 송풍 날개에 접근하지 마세요. 새시로부터 팬 조립품을 제거할 때 팬은 여전히 회전하고 있을 수 있습니다. 팬 조립품 외관의 열려있는 부분들로부터 손가락 및 스크류드라이버, 다른 물체들이 가까이 하지 않도록 배치해 주십시오.

Waarschuwing

Gevaarlijk bewegende onderdelen. Houd voldoende afstand tot de bewegende ventilatorbladen. Het is mogelijk dat de ventilator nog draait tijdens het verwijderen van het ventilatorsamenstel uit het chassis. Houd uw vingers, schroevendraaiers en eventuele andere voorwerpen uit de buurt van de openingen in de ventilatorbehuizing.

Power Cable and AC Adapter



Warning! When installing the product, use the provided or designated connection cables, power cables and AC adaptors. Using any other cables and adaptors could cause a malfunction or a fire. Electrical Appliance and Material Safety Law prohibits the use of UL or CSA -certified cables (that have UL/CSA shown on the cord) for any other electrical devices than products designated by Supermicro only.

電源コードとACアダプター

製品を設置する場合、提供または指定および購入された接続ケーブル、電源コードとACアダプターを該当する地域の条例や安全基準に適合するコードサイズやプラグと共に使用下さい。他のケーブルやアダプタを使用すると故障や火災の原因になることがあります。

電気用品安全法は、ULまたはCSA認定のケーブル(UL/CSAマークがコードに表記)を Supermicro が指定する製品以外に使用することを禁止しています。

警告

安装此产品时,请使用本身提供的或指定的或采购的连接线,电源线和电源适配器。包含遵照当地法规和安全要求的合规的电源线尺寸和插头。使用其它线材或适配器可能会引起故障或火灾。除了Supermicro所指定的产品,电气用品和材料安全法律规定禁止使用未经UL或CSA认证的线材。(线材上会显示UL/CSA符号)。

警告

安裝此產品時,請使用本身提供的或指定的或採購的連接線,電源線和電源適配器。包含遵照當地法規和安全要求的合規的電源線尺寸和插頭。使用其它線材或適配器可能會引起故障或火災。除了Supermicro所指定的產品,電氣用品和材料安全法律規定禁止使用未經UL或CSA認證的線材。(線材上會顯示UL/CSA符號)。

Warnung

Nutzen Sie beim Installieren des Produkts ausschließlich die von uns zur Verfügung gestellten Verbindungskabeln, Stromkabeln und/oder Adapter, die Ihre örtlichen Sicherheitsstandards einhalten. Der Gebrauch von anderen Kabeln und Adapter können Fehlfunktionen oder Feuer verursachen. Die Richtlinien untersagen das Nutzen von UL oder CAS zertifizierten Kabeln (mit UL/CSA gekennzeichnet), an Geräten oder Produkten die nicht mit Supermicro gekennzeichnet sind.

¡Advertencia!

Cuando instale el producto, utilice la conexión provista o designada o procure cables, Cables de alimentación y adaptadores de CA que cumplan con los códigos locales y los requisitos de seguridad, incluyendo el tamaño adecuado del cable y el enchufe. El uso de otros cables y adaptadores podría causar un mal funcionamiento o un incendio. La Ley de Seguridad de Aparatos Eléctricos y de Materiales prohíbe El uso de cables certificados por UL o CSA (que tienen el certificado UL / CSA en el código) para cualquier otros dispositivos eléctricos que los productos designados únicamente por Supermicro.

Attention

Lors de l'installation du produit, utilisez les cables de connection fournis ou désigné ou achetez des cables, cables de puissance et adaptateurs respectant les normes locales et les conditions de securite y compris les tailles de cables et les prises electriques appropries. L'utilisation d'autres cables et adaptateurs peut provoquer un dysfonctionnement ou un incendie. Appareils électroménagers et la Loi sur la Sécurité Matériel interdit l'utilisation de câbles certifiés- UL ou CSA (qui ont UL ou CSA indiqué sur le code) pour tous les autres appareils électriques sauf les produits désignés par Supermicro seulement.

AC ימאתמו מיי למשח מילבכ

!הרהזא

ךרוצל ומאתוה וא ושכרנ רשא AC מיימאתמו מיקפס, מילבכב שמתשהל שי, רצומה תא מיניקתמ רשאכ לכב שומיש . עקתהו לבכה לש הנוכח הדימ ללוכ, תוימוקמה תוחיטבה תושירדל ומאתוה רשאו, הנקתהה למשחה ירישכמב שומישה יקוחל מאתהב. ילמשח רצק וא הלקתל מורגל לולע, רחא גוסמ מאתמ וא לבכ לש דוק מהילע עיפומ רשאכ) UL-ב או CSA-ב -ב מיכמומה מילבכב שמתשהל רוסיא מייק, תוחיטבה יקוחו דבלב Supermicro י"ע מאתוה רשא רצומב קר אלא, רחא ילמשח רצומ לכ רובע (UL/CSA)

תאלבאלא אארשב מץ וא אדדחמלא וא ארפוטמלא תאליטוטלא מאדחטסאב מץ, אגתנמלא בייקרת דנע לכלז יפ אמב אילחמלא אמאלסלא תאבלטתמו נינאווב מאזתלאלא עמ דדרתמלא ראיטלא תאלוחמו אילברמלא קיירח וא לטע יפ בבסטטי דץ ירשא תאלוחמו תאלבאלא יא מאדחטסא. מילסלא סבאלאו לטומוא מץ ח. CSA וא UL לבק נמ אדמטעמלא תאלבאלא מאדחטסא תאדעמלא אילברמלא אזהאלל אמאלסלא נונאק רזחי Supermicro לבק נמ אדדחמלא אילחמלא תאגתנמלא רייג ירשא תאדעמ יא עמ (UL/CSA) אמאלע למחתיטלאו

전원 케이블 및 AC 어댑터

경고! 제품을 설치할 때 현지 코드 및 적절한 굵기의 코드와 플러그를 포함한 안전 요구 사항을 준수하여 제공되거나 지정된 연결 혹은 구매 케이블, 전원 케이블 및 AC 어댑터를 사용하십시오.

다른 케이블이나 어댑터를 사용하면 오작동이나 화재가 발생할 수 있습니다. 전기 용품 안전법은 UL 또는 CSA 인증 케이블 (코드에 UL / CSA가 표시된 케이블)을 Supermicro 가 지정한 제품 이외의 전기 장치에 사용하는 것을 금지합니다.

Stroomkabel en AC-Adapter

Waarschuwing! Bij het aansluiten van het Product uitsluitend gebruik maken van de geleverde Kabels of een andere geschikte aan te schaffen Aansluitmethode, deze moet altijd voldoen aan de lokale voorschriften en veiligheidsnormen, inclusief de juiste kabeldikte en stekker. Het gebruik van niet geschikte Kabels en/of Adapters kan een storing of brand veroorzaken. Wetgeving voor Elektrische apparatuur en Materiaalveiligheid verbied het gebruik van UL of CSA -gecertificeerde Kabels (met UL/CSA in de code) voor elke andere toepassing dan de door Supermicro hiervoor beoogde Producten.

Appendix B

System Specifications

Processors (per node)

Supports dual 4th Gen Intel Xeon Scalable Processors (in Socket E LGA 4677) with four UPIs (16 GT/s max.) and a TDP (Thermal Design Power) up to 350 W.

Note: Refer to the motherboard specifications pages on our website for updates to supported processors.

Chipset

Intel C741 PCH

BIOS

AMI SPI BIOS

EFI GUI, SPI dual/quad speed control, riser card auto detection, RTC (Real Time Clock) wakeup, IPMIView, SMCIPMITOOL, IPMI CFG, SuperDoctor5, SD3 (for Windows OS), SD2 (for Linux OS), Redundant power supply unit detection, SSM and SUM-OOB/InBand support

Memory (per node)

Supports up to 4 TB RDIMM DDR5 (288-pin) ECC memory with speeds up to 4800 MT/s in 16 DIMM slots.

Storage Drives

Front hot-swappable drives include:

SYS-621BT-HNTR: 2 LFF Gen5 NVMe/SATA drives and 1 LFF Gen4 NVMe/SATA drive

SYS-621BT-HNC8R: 2 LFF Gen5 NVMe/SAS drives and 1 LFF Gen4 NVMe/SAS drive

Internal M.2 drives per node include:

Default carrier with two M.2 NVMe SSDs

Optional carrier with two M.2 NVMe SSDs and Marvell HW RAID

Internal Connector:

VROC key header

PCI Expansion Slots (per node)

Two PCIe 5.0 x16 slots

Networking (per node)

One AIOM or any compliant OCP 3.0 SFF Network Interface Card

One dedicated LAN port for BMC (via AST2600 BMC RoT 2.0)

Input/Output (per node)

Two USB 3.1 ports

One VGA port

Motherboard (per node)

X13DET-B, 7.62" (W) x 18.80" (L) Big Twin (193.55 mm x 477.52 mm)

Chassis

CSE-827BQ2-R3K04P; 2U rackmount; (WxHxD) 17.6" x 3.5" x 30.5" (446 x 88 x 774 mm)

System Cooling

Four 8-cm mid-chassis fans, two CPU heat sinks per node, and one air shroud per node

Power Supply

Model: PWS-3K04A-1R, 3000 W redundant module, 80Plus Titanium level

Important: Power supply redundancy is supported only with a 240 VAC or 240 VDC input.

AC Input Voltages: 100-240 VAC

Rated Input Current:

1400 W: 100-127 Vac

2880 W: 200-207 Vac

3000 W: 208-240 Vac

3000 W: 240Vdc (for CQC only)

Rated Input Frequency: 50-60 Hz

Rated Output Power: +12 V

MAX: 116 A / Min: 0 A (100-127 Vac)

MAX: 240 A / Min: 0 A (200-207 Vac)

MAX: 250 A / Min: 0 A (208-240 Vac)

MAX: 250 A / Min: 0 A (240 Vdc, CQC Only)

Standby +12 Vsb: Max: 2.1 A / Min: 0 A

Operating Environment

Operating Temperature: 10°C to 35°C (50°F to 95°F)

Non-operating Temperature: -30°C to 60°C (-22°F to 140°F)

Operating Relative Humidity: 8% to 80% (non-condensing)

Non-operating Relative Humidity: 8% to 90% (non-condensing)

Regulatory Compliance

FCC, ICES, CE, VCCI, RCM, UKCA, NRTL, CB

Applied Directives, Standards

EMC/EMI: 2014/30/EU (EMC Directive)

Electromagnetic Compatibility Regulations 2016

FCC Part 15

ICES-003

VCCI-CISPR 32

AS/NZS CISPR 32

EN/BS 55032

EN/BS 55035

CISPR 32

EN/BS 61000-3-2

EN/BS 61000-3-3

EN/BS 61000-4-2

EN/BS 61000-4-3

EN/BS 61000-4-4

EN/BS 61000-4-5

EN/BS 61000-4-6

EN/BS 61000-4-8

EN/BS 61000-4-11

Green Environment:

2011/65/EU (RoHS Directive)

EC 1907/2006 (REACH)

2012/19/EU (WEEE Directive)

California Proposition 65

Product Safety: 2014/35/EU (LVD Directive)

Electrical Equipment (Safety) Regulations 2016

UL/CSA 62368-1 (USA and Canada)

IEC/EN 62368-1

Perchlorate Warning

California Best Management Practices Regulations for Perchlorate Materials: This Perchlorate warning applies only to products containing CR (Manganese Dioxide) Lithium coin cells. "Perchlorate Material-special handling may apply. See www.dtsc.ca.gov/hazardouswaste/perchlorate"

この装置は、クラスA機器です。この装置を住宅環境で使用すると電波妨害を引き起こすことがあります。この場合には使用者が適切な対策を講ずるよう要求されることがあります。

VCCI - A

BSMI/RoHS

限用物質含有情況標示聲明書

Declaration of the Presence Condition of the Restricted Substances Marking

設備名稱：伺服器 / Server 型號（型式）： 217B-R30X13 Equipment name Type designation (Type)						
(系列型號: 217B-30, 217B-R22X13, 217B - 22, 827B-R30X13, 827B-30, 827B -R22X13, 827B -22, SYS-221BT-HNTR, SYS-221BT-HNR, SYS-221BT-HNC8R, SYS-221BT-HNC9R, SYS-621BT-HNTR, SYS-621BT-HNC8R)						
單元 Unit	限用物質及其化學符號 Restricted substances and its chemical symbols					
	鉛Lead (Pb)	汞Mercury (Hg)	鎘Cadmium (Cd)	六價鉻Hexavalent chromium (Cr ⁺⁶)	多溴聯苯Polybrominated biphenyls (PBB)	多溴二苯醚Polybrominated diphenyl ethers (PBDE)
機殼 (Chassis)	○	○	○	○	○	○
機殼風扇 (Chassis Fan)	—	○	○	○	○	○
線材 (Cable)	○	○	○	○	○	○
主機板 (Motherboard)	—	○	○	○	○	○
電源供應器 (Power Supply)	—	○	○	○	○	○
硬碟 (SSD)	—	○	○	○	○	○
電源背板 (PDB)	—	○	○	○	○	○
附加卡 (Add-on card)	—	○	○	○	○	○
備考1. “超出0.1 wt %” 及 “超出0.01 wt %” 係指限用物質之百分比含量超出百分比含量基準值。 Note 1 : “Exceeding 0.1 wt %” and “exceeding 0.01 wt %” indicate that the percentage content of the restricted substance exceeds the reference percentage value of presence condition.						
備考2. “○” 係指該項限用物質之百分比含量未超出百分比含量基準值。 Note 2 : “○” indicates that the percentage content of the restricted substance does not exceed the percentage of reference value of presence.						
備考3. “—” 係指該項限用物質為排除項目。 Note 3 : The “—” indicates that the restricted substance corresponds to the exemption.						

警告：為避免電磁干擾，本產品不應安裝或使用於住宅環境。

輸入額定：

PWS-2K22A-1R

100-127V ~, 60-50Hz, 12-11A (X2)

200-240V ~, 60-50Hz, 10-9.8A (X2)

PWS-3K04A-1R

100-127V ~, 60-50Hz, 16-13A (X2)

200-240V ~, 60-50Hz, 16-14A (X2)

*使用者不能任意拆除或替換內部配備

*報驗義務人之姓名或名稱：美超微電腦股份有限公司

*報驗義務人之地址：新北市中和區建一路 150 號 3 樓