



# A+ SERVER AS -2115GT-HNTF



USER'S MANUAL

Revision 1.1

The information in this User's Manual has been carefully reviewed and is believed to be accurate. The vendor assumes no responsibility for any inaccuracies that may be contained in this document, and makes no commitment to update or to keep current the information in this manual, or to notify any person or organization of the updates. Please Note: For the most up-to-date version of this manual, please see our website at [www.supermicro.com](http://www.supermicro.com).

Super Micro Computer, Inc. ("Supermicro") reserves the right to make changes to the product described in this manual at any time and without notice. This product, including software and documentation, is the property of Supermicro and/or its licensors, and is supplied only under a license. Any use or reproduction of this product is not allowed, except as expressly permitted by the terms of said license.

IN NO EVENT WILL Super Micro Computer, Inc. BE LIABLE FOR DIRECT, INDIRECT, SPECIAL, INCIDENTAL, SPECULATIVE OR CONSEQUENTIAL DAMAGES ARISING FROM THE USE OR INABILITY TO USE THIS PRODUCT OR DOCUMENTATION, EVEN IF ADVISED OF THE POSSIBILITY OF SUCH DAMAGES. IN PARTICULAR, SUPER MICRO COMPUTER, INC. SHALL NOT HAVE LIABILITY FOR ANY HARDWARE, SOFTWARE, OR DATA STORED OR USED WITH THE PRODUCT, INCLUDING THE COSTS OF REPAIRING, REPLACING, INTEGRATING, INSTALLING OR RECOVERING SUCH HARDWARE, SOFTWARE, OR DATA.

Any disputes arising between manufacturer and customer shall be governed by the laws of Santa Clara County in the State of California, USA. The State of California, County of Santa Clara shall be the exclusive venue for the resolution of any such disputes. Supermicro's total liability for all claims will not exceed the price paid for the hardware product.

FCC Statement: This equipment has been tested and found to comply with the limits for a Class A or Class B digital device pursuant to Part 15 of the FCC Rules. These limits are designed to provide reasonable protection against harmful interference when the equipment is operated in industrial environment for Class A device or in residential environment for Class B device. This equipment generates, uses, and can radiate radio frequency energy and, if not installed and used in accordance with the manufacturer's instruction manual, may cause harmful interference with radio communications. Operation of this equipment in a residential area is likely to cause harmful interference, in which case you will be required to correct the interference at your own expense.

California Best Management Practices Regulations for Perchlorate Materials: This Perchlorate warning applies only to products containing CR (Manganese Dioxide) Lithium coin cells. "Perchlorate Material-special handling may apply. See [www.dtsc.ca.gov/hazardouswaste/perchlorate](http://www.dtsc.ca.gov/hazardouswaste/perchlorate)".



WARNING: This product can expose you to chemicals including lead, known to the State of California to cause cancer and birth defects or other reproductive harm. For more information, go to [www.P65Warnings.ca.gov](http://www.P65Warnings.ca.gov).

The products sold by Supermicro are not intended for and will not be used in life support systems, medical equipment, nuclear facilities or systems, aircraft, aircraft devices, aircraft/emergency communication devices or other critical systems whose failure to perform be reasonably expected to result in significant injury or loss of life or catastrophic property damage. Accordingly, Supermicro disclaims any and all liability, and should buyer use or sell such products for use in such ultra-hazardous applications, it does so entirely at its own risk. Furthermore, buyer agrees to fully indemnify, defend and hold Supermicro harmless for and against any and all claims, demands, actions, litigation, and proceedings of any kind arising out of or related to such ultra-hazardous use or sale.

Manual Revision 1.1

Release Date: June 09, 2025

Unless you request and receive written permission from Super Micro Computer, Inc., you may not copy any part of this document. Information in this document is subject to change without notice. Other products and companies referred to herein are trademarks or registered trademarks of their respective companies or mark holders.

Copyright © 2025 by Super Micro Computer, Inc.  
All rights reserved.

**Printed in the United States of America**

# Preface

## About this Manual

This manual is written for professional system integrators and PC technicians. It provides information for the installation and use of the A+ Server. Installation and maintenance should be performed by certified service technicians only.

Please refer to the AS -2115GT-HNTF server specifications page on our website for updates on supported memory, processors and operating systems (<http://www.supermicro.com>).

## Notes

For your system to work properly, please follow the links below to download all necessary drivers/utilities and the user's manual for your server.

- Supermicro product manuals: <http://www.supermicro.com/support/manuals/>
- Product drivers and utilities: <https://www.supermicro.com/wdl>
- Product safety info: [http://www.supermicro.com/about/policies/safety\\_information.cfm](http://www.supermicro.com/about/policies/safety_information.cfm)

If you have any questions, please contact our support team at:  
[support@supermicro.com](mailto:support@supermicro.com)

This manual may be periodically updated without notice. Please check the Supermicro website for possible updates to the manual revision level.

## Secure Data Deletion

A secure data deletion tool designed to fully erase all data from storage devices can be found on our website: [https://www.supermicro.com/about/policies/disclaimer.cfm?url=/wdl/utility/Lot9\\_Secure\\_Data\\_Deletion\\_Utility/](https://www.supermicro.com/about/policies/disclaimer.cfm?url=/wdl/utility/Lot9_Secure_Data_Deletion_Utility/)

## Warnings

Special attention should be given to the following symbols used in this manual.



**Warning!** Indicates important information given to prevent equipment/property damage or personal injury.



**Warning!** Indicates high voltage may be encountered when performing a procedure.

# Contents

Contacting Supermicro.....	8
<b>Chapter 1 Introduction</b>	
1.1 Overview.....	9
1.2 System Features .....	10
Front View .....	10
Control Panel.....	11
Rear View.....	12
Network Ports.....	13
1.3 System Architecture .....	14
Main Components .....	14
System Block Diagram.....	15
1.4 Motherboard Layout .....	16
Quick Reference Table.....	17
<b>Chapter 2 Server Installation</b>	
2.1 Overview.....	18
2.2 Preparing for Setup.....	18
Choosing a Setup Location.....	18
Rack Precautions .....	18
Server Precautions.....	19
Rack Mounting Considerations .....	19
Ambient Operating Temperature.....	19
Airflow .....	19
Mechanical Loading.....	19
Circuit Overloading .....	20
Reliable Ground.....	20
2.3 Installing the Rails .....	21
Identifying the Rails.....	21
Adjusting the Rail Length .....	21
Installing the Rails on a Rack .....	22
Chassis Installation .....	23

---

---

## **Chapter 3 Maintenance and Component Installation**

3.1 Removing Power .....	24
3.2 Accessing the System.....	25
Replacing a Computing Node Tray .....	25
Removing the Chassis Cover .....	27
3.3 Static-Sensitive Devices.....	28
Precautions .....	28
Unpacking .....	28
3.4 Processor and Heatsink Installation.....	29
3.5 Memory.....	37
Memory Support.....	37
DIMM Module Population Sequence .....	39
DIMM Installation .....	40
DIMM Removal .....	40
Motherboard Battery .....	41
3.6 Chassis Components .....	42
Storage Drives .....	42
Drive Carrier Indicators .....	42
Drive Configuration .....	43
Removing/Installing Drives.....	44
2.5" Drive Cage Removal/Installation.....	44
Hot-Swap for NVMe Drives.....	47
Checking the Temperature of an NVMe Drive .....	48
AIOM Card .....	48
I/O Card.....	49
3.7 System Cooling .....	50
Fans .....	50
Installing the Air Shroud.....	51
3.8 Power Supply .....	52
3.9 BMC Reset.....	53

---

---

## ***Chapter 4 Motherboard Connections***

4.1 Power Connections .....	54
4.2 Headers and Connectors .....	55
4.3 Jumper Settings .....	56
How Jumpers Work.....	56
4.4 LED Indicators.....	58

## ***Chapter 5 Software***

5.1 Microsoft Windows OS Installation.....	59
5.2 Driver Installation.....	61
5.3 SuperDoctor® 5.....	62
5.4 IPMI .....	63

## ***Chapter 6 Optional Components***

6.1 Optional Parts List.....	64
6.2 TPM Security Module.....	64

## ***Chapter 7 Troubleshooting and Support***

7.1 Information Resources .....	65
Website .....	65
Direct Links for the AS -2115GT-HNTF System.....	65
Direct Links for General Support and Information .....	65
7.2 BMC Interface .....	66
7.3 Troubleshooting Procedures .....	67
Before Power On .....	67
No Power .....	67
No Video .....	68
System Boot Failure .....	68
Memory Errors .....	68
The System Cannot Retain the Setup Configuration .....	68
If the System Becomes Unstable.....	69
7.4 Technical Support Procedures .....	70
7.5 Frequently Asked Questions .....	71
7.6 Returning Merchandise for Service.....	72

7.7 Battery Removal and Installation .....72

    Battery Removal.....72

    Proper Battery Disposal .....73

    Battery Installation.....73

7.8 BMC Reset .....74

7.9 Where to Get Replacement Components .....74

7.10 Reporting an Issue.....75

    Technical Support Procedures .....75

    Vendor Support Filing System .....75

7.11 Feedback.....75

7.12 Contacting Supermicro.....76

***Appendix A Standardized Warning Statements for AC Systems***

***Appendix B System Specifications***

---

---

## Contacting Supermicro

### Headquarters

Address: Super Micro Computer, Inc.  
980 Rock Ave.  
San Jose, CA 95131 U.S.A.

Tel: +1 (408) 503-8000

Fax: +1 (408) 503-8008

Email: marketing@supermicro.com (General Information)  
Sales-USA@supermicro.com (Sales Inquiries)  
Government\_Sales-USA@supermicro.com (Gov. Sales Inquiries)  
support@supermicro.com (Technical Support)  
RMA@supermicro.com (RMA Support)  
Webmaster@supermicro.com (Webmaster)

Website: [www.supermicro.com](http://www.supermicro.com)

### Europe

Address: Super Micro Computer B.V.  
Het Sterrenbeeld 28, 5215 ML  
's-Hertogenbosch, The Netherlands

Tel: +31 (0) 73-6400390

Fax: +31 (0) 73-6416525

Email: Sales\_Europe@supermicro.com (Sales Inquiries)  
Support\_Europe@supermicro.com (Technical Support)  
RMA\_Europe@supermicro.com (RMA Support)

Website: [www.supermicro.nl](http://www.supermicro.nl)

### Asia-Pacific

Address: Super Micro Computer, Inc.  
3F, No. 150, Jian 1st Rd.  
Zhonghe Dist., New Taipei City 235  
Taiwan (R.O.C)

Tel: +886-(2) 8226-3990

Fax: +886-(2) 8226-3992

Email: Sales-Asia@supermicro.com.tw (Sales Inquiries)  
Support@supermicro.com.tw (Technical Support)  
RMA@supermicro.com.tw (RMA Support)

Website: [www.supermicro.com.tw](http://www.supermicro.com.tw)

# Chapter 1

## Introduction

### 1.1 Overview

This chapter provides a brief outline of the functions and features of the A+ server AS -2115GT-HNTF. It is based on the H13SST-G motherboard and the CSE-GT214BF-R2K21BP2 chassis. The following provides an overview of the specifications and capabilities of the system.

System Overview	
<b>Motherboard (per node)</b>	H13SST-G
<b>Chassis</b>	CSE-GT214BF-R2K21BP2
<b>CPU</b>	Single AMD EPYC™ 9004/9005 series processors in SP5 socket and a Thermal Design Power unit up to 400 W (*AMD EPYC™ 9005 series drop-in support requires board revision 2.x) The power of the TDP unit depends on thermal validation and system configuration. Contact a Supermicro representative for details.
<b>Memory (per node)</b>	12 DIMM Slots Max Memory (1DPC): Up to 3 TB 4800 MT/s ECC DDR5 RDIMM (AMD EPYC™ 9004 Series Processor, MB R1.x/R2.0/R2.01) Max Memory (1DPC): Up to 3 TB 6000 MT/s ECC DDR5 RDIMM (AMD EPYC™ 9005 Series Processor, MB R2.0) Max Memory (1DPC): Up to 3 TB 6400 MT/s ECC DDR5 RDIMM (AMD EPYC™ 9005 Series Processor, MB R2.01) *For details, please refer to <a href="#">Section 3.5</a> .
<b>Management Chipset</b>	System on Chip (SoC)
<b>Storage Drives (per node)</b>	Optional four 2.5" hot-swap drive carriers for NVMe or SATA drive
<b>Power</b>	Two 2200 W Redundant (1 + 1) Titanium Level (96%) power supplies (Power supply full redundancy based on configuration and application load)
<b>Cooling</b>	Two 80-mm mid chassis fans per system, one CPU air shroud per node, one CPU heatsink per node
<b>Input/Output</b>	Each GrandTwin I/O module integrates a network solution and the I/O ports, including: Two USB 3.0 ports One VGA port One BMC Network port
<b>Security</b>	One TPM 2.0 header per node HW Root of Trust
<b>Form Factor</b>	2U rackmount, (WxHxD) 17.67 x 3.46 x 28" (449 x 88 x 711.2 mm)

**Notes:** A Quick Reference Guide can be found on the product page of the Supermicro website. The following safety models associated with the AS -2115GT-HNTF have been certified as compliant with UL or CSA: GT214BF-4N and GT214BF-R22H13.

## 1.2 System Features

The following views of the system display the main features. Refer to [Appendix B](#) for additional specifications.

### Front View

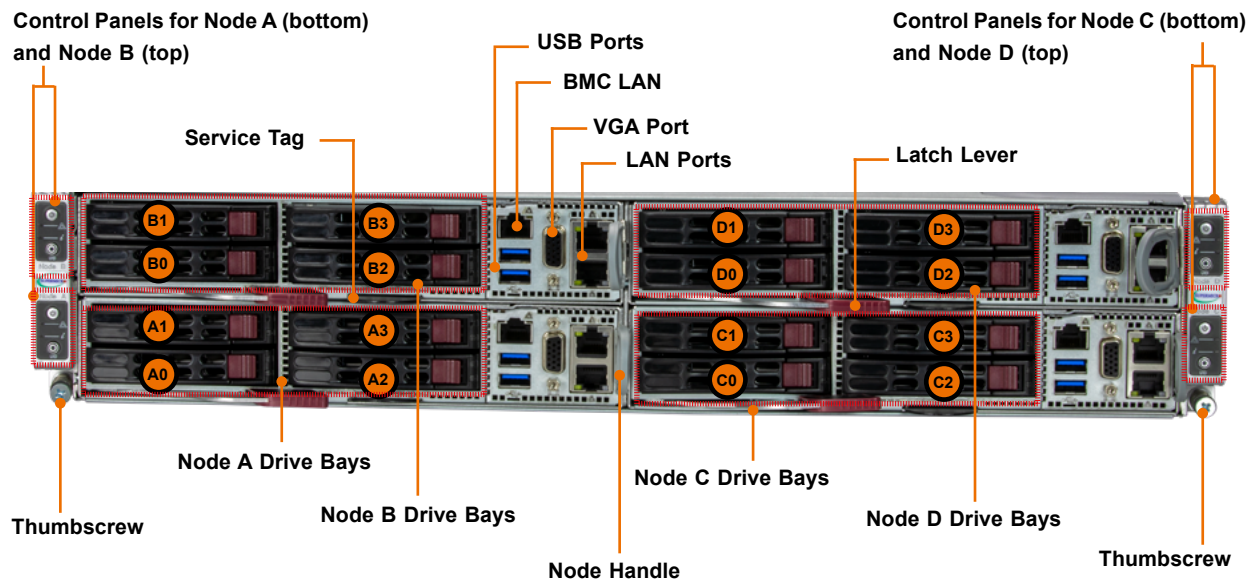

Figure 1-1. Front View

System Features: Front	
Feature	Description
Control Panel	Four control panels with labels located as follows: node A bottom left, node B top left, node C bottom right, and node D top right.
Service Tag	Pull-out service tags with BMC password labels for each node.
Drive Bays	16 hot-swappable drive bays (four per node) (optional)
BMC LAN	One BMC dedicated LAN port
USB Ports	Two USB 3.0 ports
VGA Port	One video port
LAN Ports	Two LANs integrated Network connections depend on GrandTwin IO solution
Node Handles	One handle per node supporting node tray removal
Thumbscrews	Two thumbscrews to secure the server onto the rack

## Control Panel

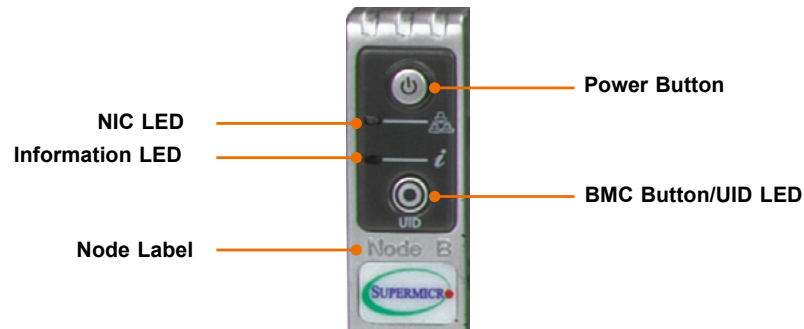

Figure 1-2. Control Panel (per node)

Control Panel Features	
Feature	Description
Power Button	The main power switch applies or removes primary power from the power supply to the server but maintains standby power.
NIC LED	Indicates network activity on the LAN when flashing.
Information LED	Universal information LED (see table below for details).
BMC Button/ UID LED (Node B)	The BMC reset button resets the BMC firmware when pressed. The unit identification (UID) button turns on or off the blue light function of the Information LED and a blue LED on the rear of the chassis. These are used to locate the server in large racks and server banks.
Node Label (Node B)	Label with the name of the node that is connected to the control panel. Labels for nodes A and C are above their control panel. Labels for nodes B and D are below their control panel.

Information LED	
Color, Status	Description
Red, solid	An overheat condition has occurred.
Red, blinking at 1 Hz	Fan failure, check for an inoperative fan.
Red, blinking at 0.25 Hz	Power failure, check for a non-operational power supply
Red, solid, with Power LED blinking green	Fault detected
Blue and red, blinking at 10 Hz	Recovery mode
Blue, solid	UID has been activated locally to locate the server in a rack environment.
Blue, blinking at 1 Hz	UID has been activated using the BMC to locate the server in a rack environment.
Blue, blinking at 2 Hz	BMC is resetting
Blue, blinking at 4 Hz	BMC is setting factory defaults
Blue, blinking at 10 Hz with Power LED blinking green	BMC/BIOS firmware is updating

### Rear View

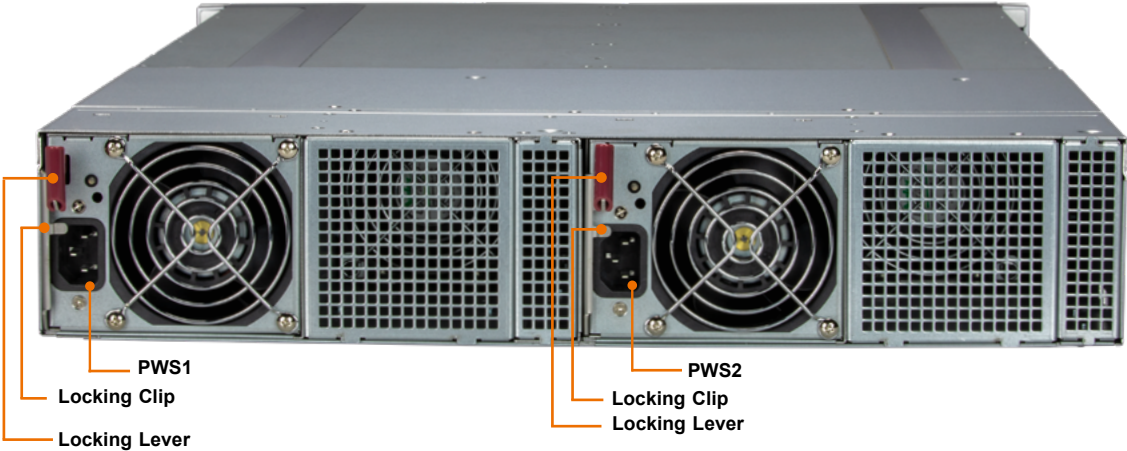

Figure 1-3. System: Rear View

System Features: Rear	
Feature	Description
Power Supplies	Two 2200 W Titanium level redundant power supply modules PWS1 on the left, and PWS2 on the right

## Network Ports

Network ports are provided by the GrandTwin IO card, which offers several choices of connection speeds and types.

**Note:** The GrandTwin IO card is sold separately, but must be added to meet the minimum complete system requirements. For the complete support list, please check the Supermicro website.

GrandTwin I/O Card Networking Add-on Card Options		
Speed	Ports	Add-on Card Part Number
10 GbE	Dual-port RJ45	AOC-GTG-I2T
25 GbE	Dual-port SFP28	AOC-G25G-M2S



Figure 1-4. AOC-GTG-I2T



Figure 1-5. AOC-G25G-M2S

## 1.3 System Architecture

This section covers the locations of the system's main components and a system block diagram.

### Main Components

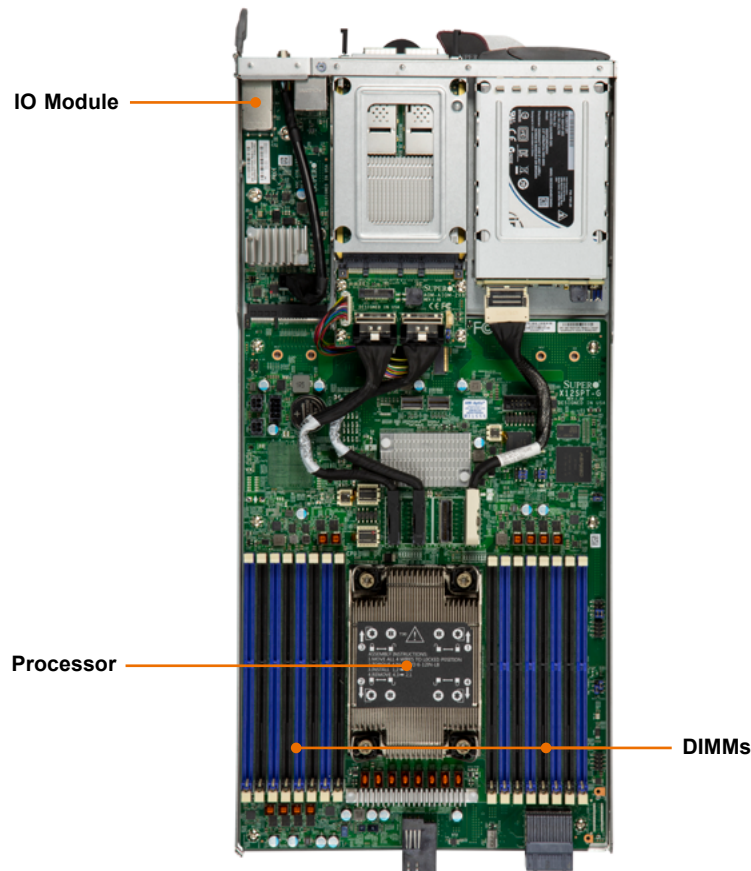

Figure 1-6. Main Component Locations

System Features: Top (per node)	
Feature	Description
IO Module	GrandTwin IO Module
Processor	Single AMD EPYC™ 9004/9005 series processors in SP5 socket and a Thermal Design Power unit up to 400 W (*AMD EPYC™ 9005 series drop-in support requires board revision 2.x) The power of the TDP unit depends on thermal validation and system configuration. Contact a Supermicro representative for details.
DIMMs	12 DIMM Slots Max Memory (1DPC): Up to 3 TB 4800 MT/s ECC DDR5 RDIMM (AMD EPYC™ 9004 Series Processor, MB R1.x/R2.0/R2.01) Max Memory (1DPC): Up to 3 TB 6000 MT/s ECC DDR5 RDIMM (AMD EPYC™ 9005 Series Processor, MB R2.0) Max Memory (1DPC): Up to 3 TB 6400 MT/s ECC DDR5 RDIMM (AMD EPYC™ 9005 Series Processor, MB R2.01) *For detail, please refer to <a href="#">Section 3.5</a> .

## System Block Diagram

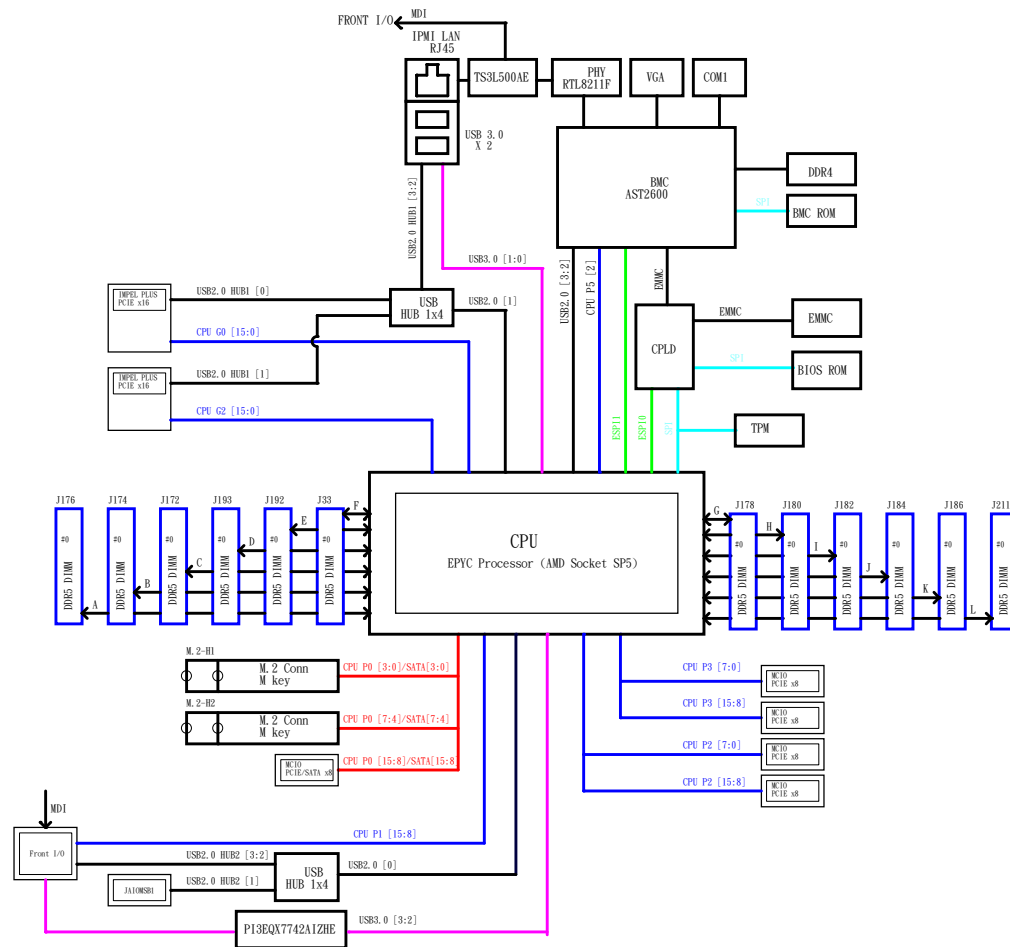

Figure 1-7. System Block Diagram

**Note:** The block diagram below shows the connections and relationships between the subsystems and major components of the overall system.

## 1.4 Motherboard Layout

Below is a layout of the H13SST-G with jumper, connector and LED locations shown. See the table on the following page for descriptions. For detailed descriptions, pinout information and jumper settings, refer to [Chapter 4](#).

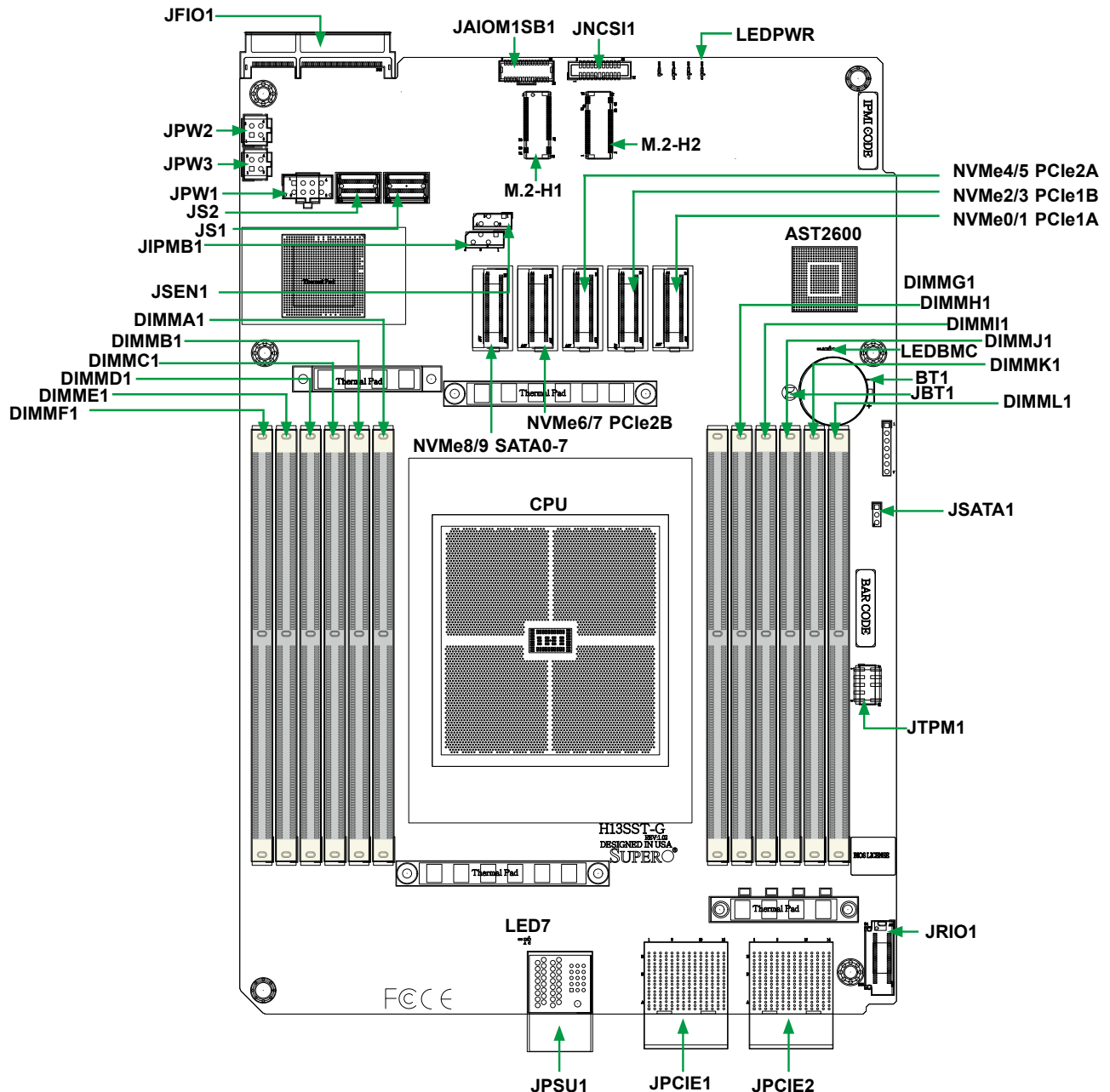

Figure 1-8. Motherboard Layout

### Notes:

- Components not documented are for internal testing only.
- Use only the correct type of onboard CMOS battery as specified by the manufacturer. Do not install the onboard battery upside down to avoid possible explosion.

## Quick Reference Table

Jumper	Description	Default Setting
JBT1	CMOS Clear	Open (Normal)
JSATA1	Hybrid MCIO select	Pins 2-3 (SATA)

LED	Description	Status
LED_PWR	Power LED	Solid Green: Power On
LEDBMC	BMC Heartbeat LED	Green: Blinking (BMC normal), Green: Fast blinking (BMC initializing)

Connector	Description
JNCSI1	NCSI connector
JAIOM1SB1	AIOM1 Sideband Signals Header
JFIO1	Grand Twin Front IPMI and Onboard NIC Module Connector
JPW1	12 V/5 V 8-pin GPU and NVMe power connector
JPW2-JPW3	12 V 4-pin GPU and NVMe power connectors
JPSU1	Serverboard Main Power Supply Connector
JRIO1	Grand Twin Rear IPMI Module Connector
BT1	Onboard Battery
M.2-H1/M.2-H2	M.2 PCIe/SATA Interfaces
NVME0/1 PCIe1A	NVMe Ports 0/1
NVME2/3 PCIe1B	NVMe Ports 2/3
NVME4/5 PCIe2A	NVMe Ports 4/5
NVME6/7 PCIe2B	NVMe Ports 6/7
NVME8/9 SATA0-7	NVMe Ports 8/9 / SATA 0~7
JIPMB1	4-pin External BMC I <sup>2</sup> C Header

**Note:** Jumpers, connectors, switches, and LED indicators that are not described in the preceding tables are for manufacturing testing purposes only, and are not covered in this manual.

# Chapter 2

## Server Installation

### 2.1 Overview

This chapter provides advice and instructions for mounting your system in a server rack. If your system is not already fully integrated with processors, system memory etc., refer to [Chapter 4](#) for details on installing those specific components.

**Important:** Electrostatic Discharge (ESD) can damage electronic components. To prevent such damage to PCBs (printed circuit boards), it is important to use a grounded wrist strap, handle all PCBs by their edges and keep them in anti-static bags when not in use.

### 2.2 Preparing for Setup

The box in which the system was shipped should include the rackmount hardware needed to install it into the rack. Please read this section in its entirety before you begin the installation.

#### Choosing a Setup Location

- The system should be situated in a clean, dust-free area that is well ventilated. Avoid areas where heat, electrical noise and electromagnetic fields are generated.
- Leave enough clearance in front of the rack so that you can open the front door completely (approximately 25 inches) and approximately 30 inches of clearance in the back of the rack to allow sufficient space for airflow and access when servicing.
- This product should be installed only in a Restricted Access Location (dedicated equipment rooms, service closets, etc.).
- This product is not suitable for use with visual display workplace devices according to §2 of the German Ordinance for Work with Visual Display Units.

#### Rack Precautions

- Ensure that the leveling jacks on the bottom of the rack are extended to the floor so that the full weight of the rack rests on them.
- In single rack installations, stabilizers should be attached to the rack. In multiple rack installations, the racks should be coupled together.

- Always make sure the rack is stable before extending a server or other component from the rack.
- You should extend only one server or component at a time - extending two or more simultaneously may cause the rack to become unstable.

## **Server Precautions**

- Review the electrical and general safety precautions in [Appendix A](#).
- Determine the placement of each component in the rack before you install the rails.
- Install the heaviest server components at the bottom of the rack first and then work your way up.
- Use a regulating uninterruptible power supply (UPS) to protect the server from power surges and voltage spikes and to keep your system operating in case of a power failure.
- Allow any drives and power supply modules to cool before touching them.
- When not servicing, always keep the front door of the rack and all covers/panels on the servers closed to maintain proper cooling.

## **Rack Mounting Considerations**

### ***Ambient Operating Temperature***

If installed in a closed or multi-unit rack assembly, the ambient operating temperature of the rack environment may be greater than the room's ambient temperature. Therefore, consideration should be given to installing the equipment in an environment compatible with the manufacturer's maximum rated ambient temperature (TMRA).

### ***Airflow***

Equipment should be mounted into a rack so that the amount of airflow required for safe operation is not compromised.

### ***Mechanical Loading***

Equipment should be mounted into a rack so that a hazardous condition does not arise due to uneven mechanical loading.

### ***Circuit Overloading***

Consideration should be given to the connection of the equipment to the power supply circuitry and the effect that any possible overloading of circuits might have on overcurrent protection and power supply wiring. Appropriate consideration of equipment nameplate ratings should be used when addressing this concern.

### ***Reliable Ground***

A reliable ground must be maintained at all times. To ensure this, the rack itself should be grounded. Particular attention should be given to power supply connections other than the direct connections to the branch circuit (i.e. the use of power strips, etc.).

**Important:** To prevent bodily injury when mounting or servicing this unit in a rack, you must take special precautions to ensure that the system remains stable. The following guidelines are provided to ensure your safety:

- This unit should be mounted at the bottom of the rack if it is the only unit in the rack.
- When mounting this unit in a partially filled rack, load the rack from the bottom to the top with the heaviest component at the bottom of the rack.
- If the rack is provided with stabilizing devices, install the stabilizers before mounting or servicing the unit in the rack.
- Slide rail mounted equipment is not to be used as a shelf or a work space.

## 2.3 Installing the Rails

This section provides information on installing the chassis into a rack unit with the rails provided. There are a variety of rack units on the market, which may mean that the assembly procedure will differ slightly from the instructions provided. You should also refer to the installation instructions that came with the rack unit you are using.

**Note:** This rail will fit a rack between 28" and 33.5" deep.

### Identifying the Rails

The package includes two rail assemblies. Each is specifically designed for the left or right side of the chassis, and so marked. Each rail consists of two sections: a front section which secures to the front post of the rack and a rear section which adjusts in length and secures to the rear post of the rack.



**Figure 2-1. Rackmount Rail  
(Left & Right rail assembly shown)**

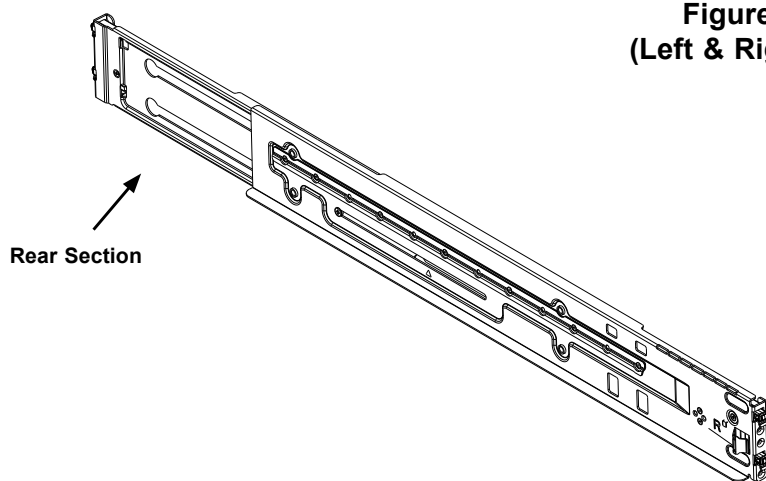

### *Adjusting the Rail Length*

Each rail assembly has a locking screw to adjust the length of the rail to fit the depth of your rack.

## Installing the Rails on a Rack

1. Loosen the adjusting screw to allow the rear section to slide in the front section.
2. Push the small hooks on the front section of the rail into the holes on the front post of the rack and then down, until the spring-loaded pegs snap into the rack holes. Secure the rail to the rack with screws.
3. Pull out the rear section of the outer rail, adjusting the length until it fits within the posts of the rack and align the small hooks with the appropriate holes on the rear post of the rack. Be sure the rail is level, then mount the rear section onto the rack. Secure the rail with screws.
4. Tighten the adjusting screw.

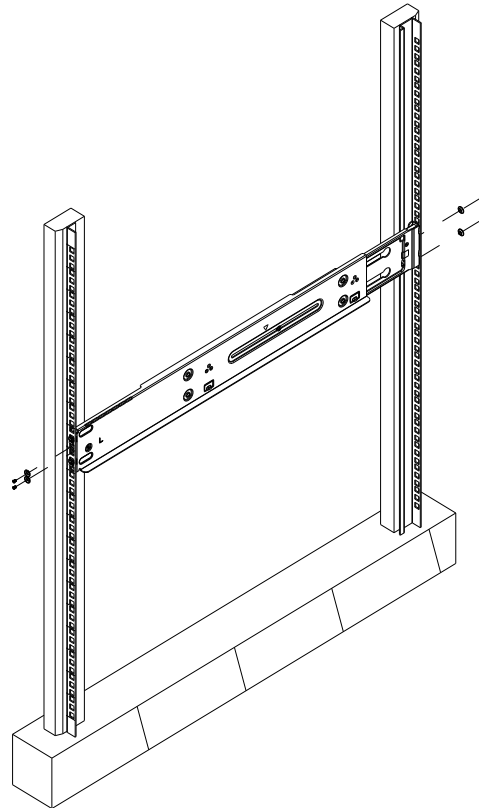

**Figure 2-2. Attaching the Rail Front to the Rack  
(Left rail shown)**

**Note:** Figures are for illustrative purposes only. Always install servers into racks from the bottom up.

### Chassis Installation

Slide the chassis into the rack so that the bottom of the chassis slides onto the bottom lip of the rails.

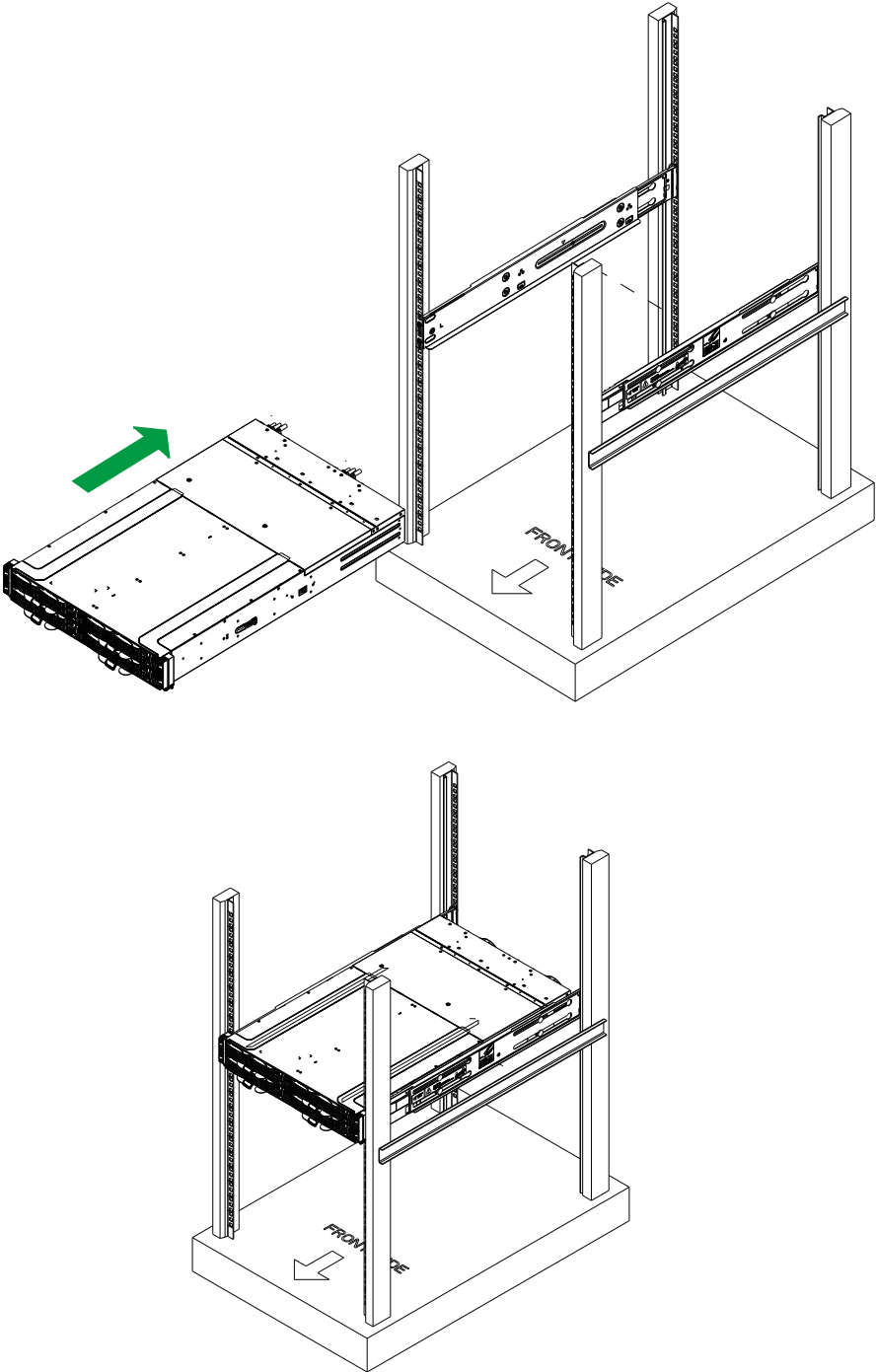

Figure 2-3. Sliding the Chassis into the Rack

**Important:** Stability hazard. The rack stabilizing mechanism must be in place, or the rack must be bolted to the floor before you slide the unit out for servicing. Failure to stabilize the rack can cause the rack to tip over.

## Chapter 3

# Maintenance and Component Installation

This chapter provides instructions on installing and replacing main system components. To prevent compatibility issues, only use components that match the specifications and/or part numbers given.

Installation or replacement of most components require that power first be removed from the system. Please follow the procedures given in each section.

### 3.1 Removing Power

Before performing some setup or maintenance tasks, use the following procedure to ensure that power has been removed from the system.

#### ***Removing Power from a Node***

Use the operating system to power down the node.

#### ***Removing Power from the System***

1. Use the operating system to power down all nodes.
2. Grasp the head of each power cord and gently pull it out of the back of the power supply.
3. Disconnect the cords from the power strip or wall outlet.

## 3.2 Accessing the System

### Replacing a Computing Node Tray

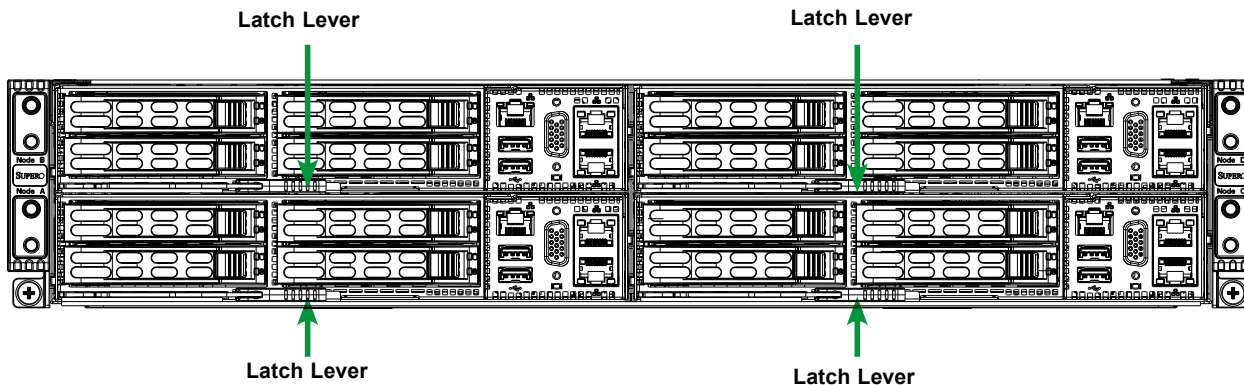

Figure 3-1. Removing a Node Tray

#### *Removing a Node*

1. Use the operating system to power down the node.
2. Remove any cables attached to the node.
3. Rotate the latch.
4. Pull out the latch lever and use it to slide the node out from the chassis front.

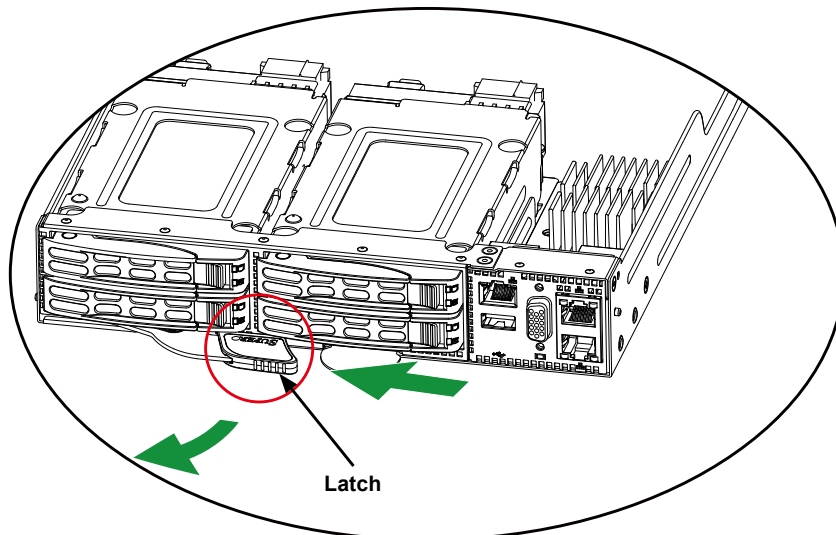
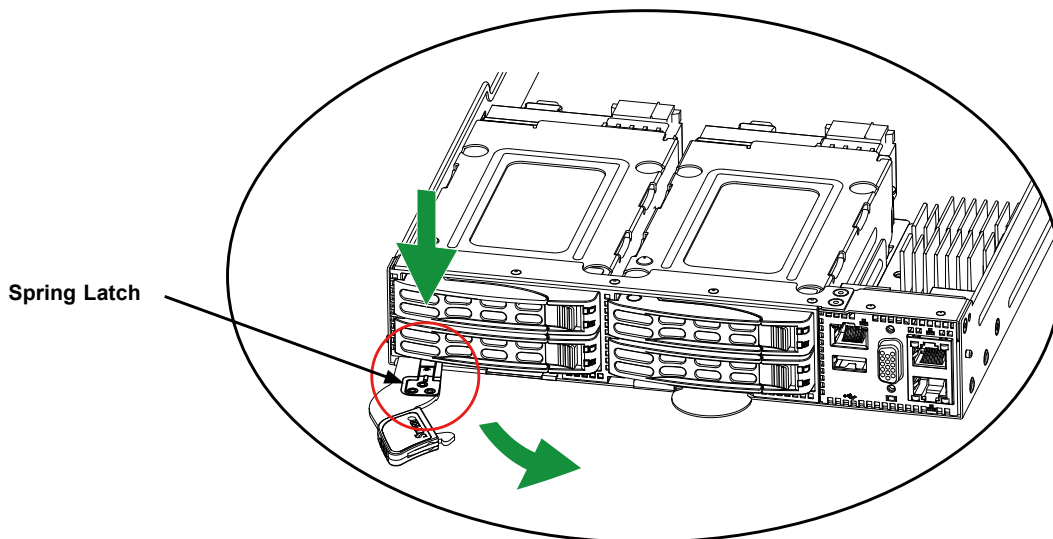

Figure 3-3. Removing a Node

***Installing a Node***

1. Insert the node until it stops.
2. Press down the spring latch.
3. Rotate the latch toward the system.



**Figure 3-2. Inserting a Node**

## Removing the Chassis Cover

You can access some chassis components, such as fans, by removing the cover.

### *Removing the Chassis Cover*

1. Remove the four screws securing the cover to the chassis.
2. Slide the cover toward the rear of the chassis.
3. Lift the top cover off of the chassis.

**Caution:** Except for short periods of time, do not operate the server without the cover in place. It provides proper airflow to prevent overheating.

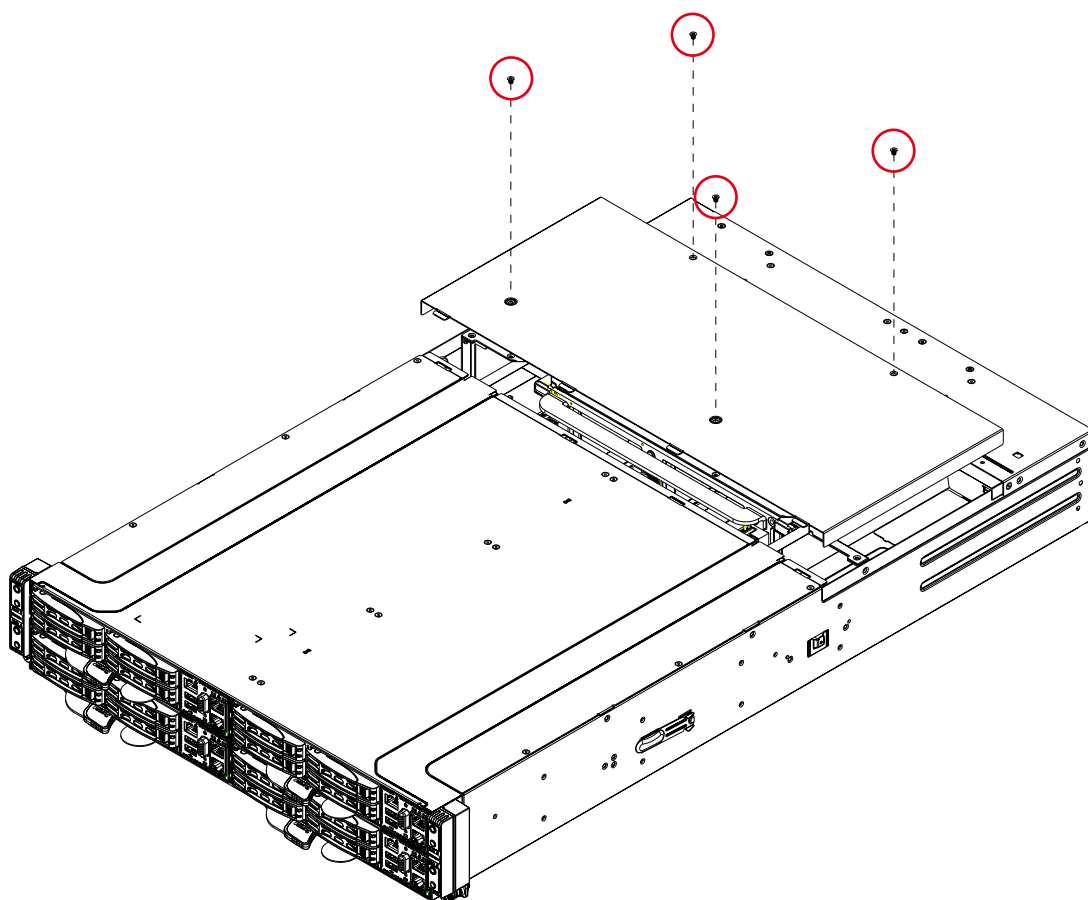

Figure 3-3. Removing the Chassis Cover

## 3.3 Static-Sensitive Devices

Electrostatic Discharge (ESD) can damage electronic components. To prevent damage to your motherboard, it is important to handle it very carefully. The following measures are generally sufficient to protect your equipment from ESD.

### Precautions

- Use a grounded wrist strap designed to prevent static discharge.
- Touch a grounded metal object before removing the board from the antistatic bag.
- Handle the board by its edges only; do not touch its components, peripheral chips, memory modules or gold contacts.
- When handling chips or modules, avoid touching their pins.
- Put the motherboard and peripherals back into their antistatic bags when not in use.
- For grounding purposes, make sure that your chassis provides excellent conductivity between the power supply, the case, the mounting fasteners and the motherboard.
- Use only the correct type of CMOS onboard battery as specified by the manufacturer. Do not install the CMOS battery upside down, which may result in a possible explosion.

### Unpacking

The motherboard is shipped in antistatic packaging to avoid static damage. When unpacking the motherboard, make sure that the person handling it is static protected.

## 3.4 Processor and Heatsink Installation

**Important:** When handling the processor package, avoid placing direct pressure on the label area of the fan.

**Important:**

- For the Processor/Heatsink installation you need to use a T20 screwdriver when opening/closing the CPU socket.
- Always connect the power cord last, and always remove it before adding, removing or changing any hardware components. Make sure that you install the processor into the CPU socket before you install the CPU heatsink.
- If you buy a CPU separately, make sure that you use an AMD-certified heatsink only. Make sure to install the motherboard into the chassis before you install the CPU heatsink.
- Make sure to install the motherboard into the chassis before you install the CPU heatsink.
- When receiving a motherboard without a processor pre-installed, make sure that the plastic CPU socket cap is in place and none of the socket pins are bent; otherwise, contact your retailer immediately.
- When installing the processor and heatsink, ensure a torque driver set to the correct force is used for each screw.
- Refer to the Supermicro website for updates on CPU support.

### *Installing the Processor and Heatsink*

1. Unscrew the screw #1 holding down the force frame.

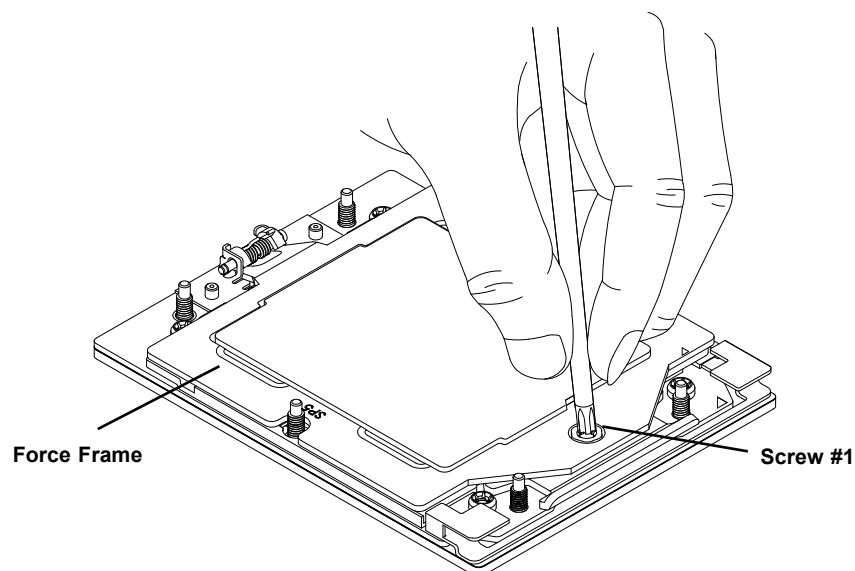

2. The spring-loaded force frame will raise up after the screw securing it (#1) is removed. Gently allow it to lift up to its stopping position.

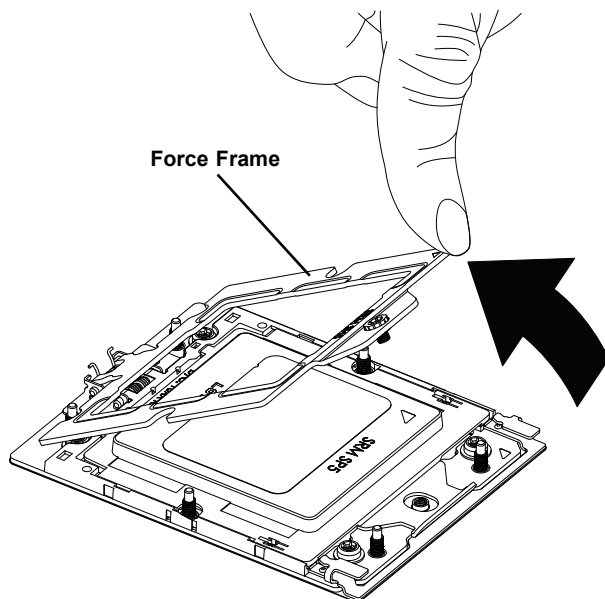

3. Lift the rail frame up by gripping the lift tabs near the front end of the rail frame. While keeping a secure grip of the rail frame, lift it to a position so you can do the next step of removing the external cap.

**Note:** The rail frame is spring loaded, so keep a secure grip on it as you lift it so it does not snap up.

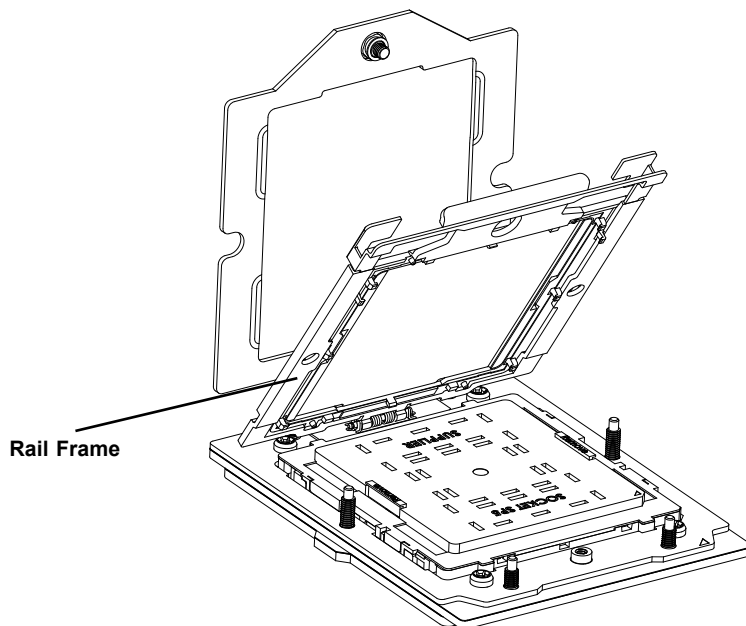

4. Remove the external cap from the rail frame by pulling it upwards through the rail guides on the rail frame.

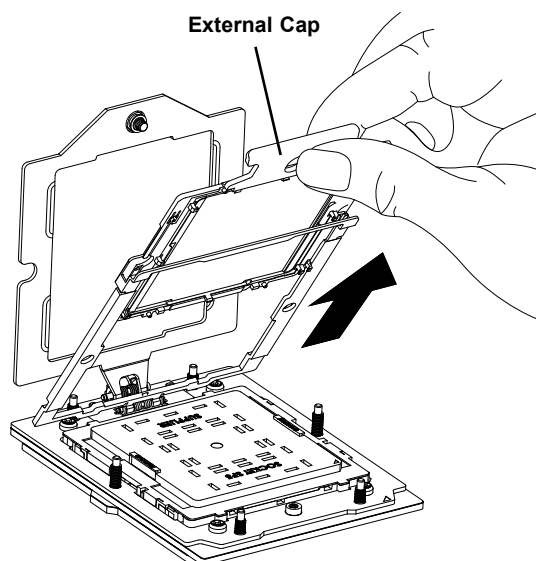

5. The CPU package is shipped from the factory with the carrier frame pre-assembled. Grip the handle of the carrier frame/CPU package assembly from its shipping tray, and while gripping the handle, align the flanges of the carrier frame onto the rails of the rail frame so its pins will be at the bottom when the rail frame is lowered later.
6. Slide the carrier frame/CPU package downwards to the bottom of the rail frame. Ensure the flanges are secure on the rails as you lower it downwards.

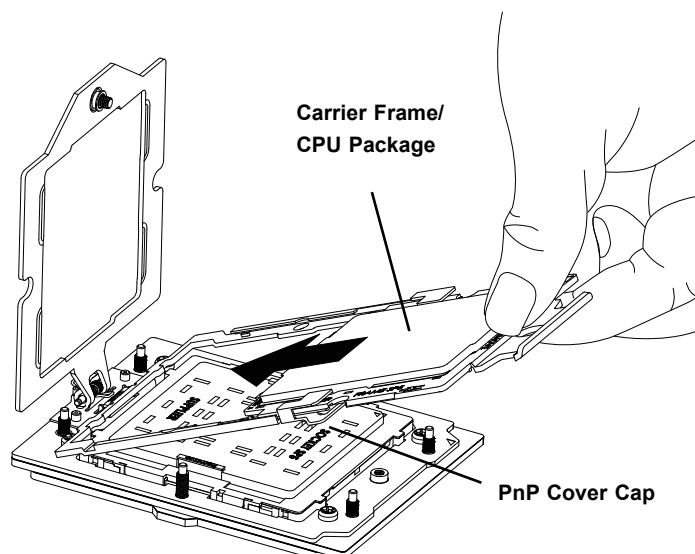

**Note:** You can only install the CPU inside the socket in one direction with the handle at the top. Make sure that it is properly inserted into the CPU socket before closing the rail frame plate. If it doesn't close properly, do not force it as it may damage your CPU. Instead, open the rail frame plate again, and double-check that the CPU is aligned properly.

7. Lift up the rail frame till it securely rests in upright position. Then remove the PnP cover cap from the CPU socket below. Grip the two lift tabs marked "Remove" at the middle of the cap and pull vertically upwards to remove the PnP cover cap.

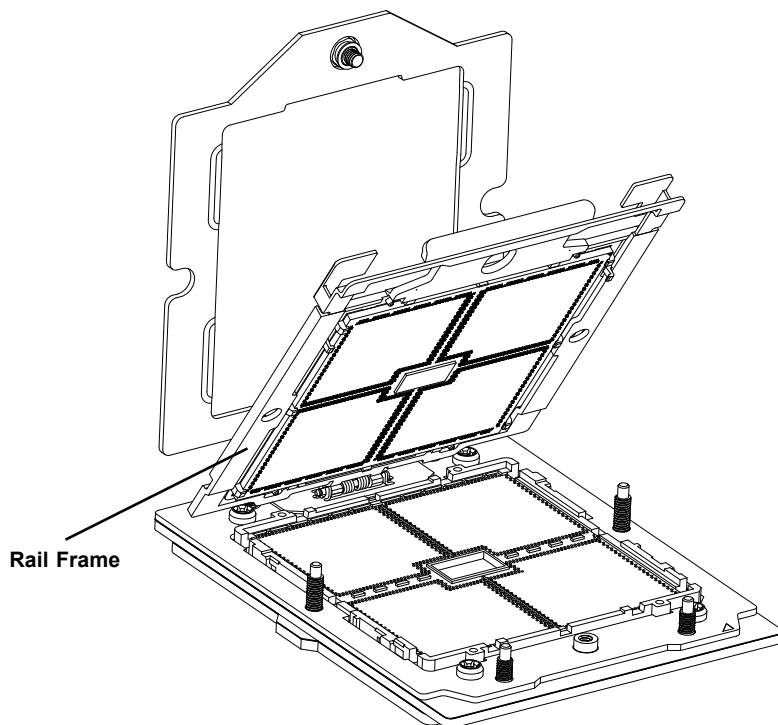

**Important:** The exposed socket contacts are extremely vulnerable and can be damaged easily. Do not touch or drop objects onto the contacts and be careful removing the PnP cover cap and when placing the rail frame over the socket.

8. Gently lower the rail frame down onto the socket until the latches on the rail frame engage with the socket housing and it rests in place. DO NOT force it into place!

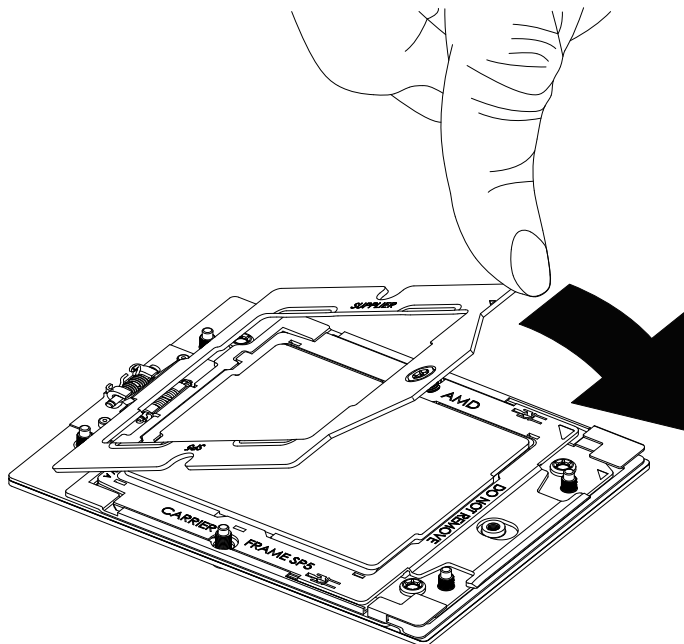

9. The force frame is spring loaded and has to be held in place before it is secured. Use a torque screwdriver, set it at 12.5~15.0 kgf-cm (10.85~13.01 lbf-in) with a Torx T20 screw head bit, to prevent damage to the CPU.

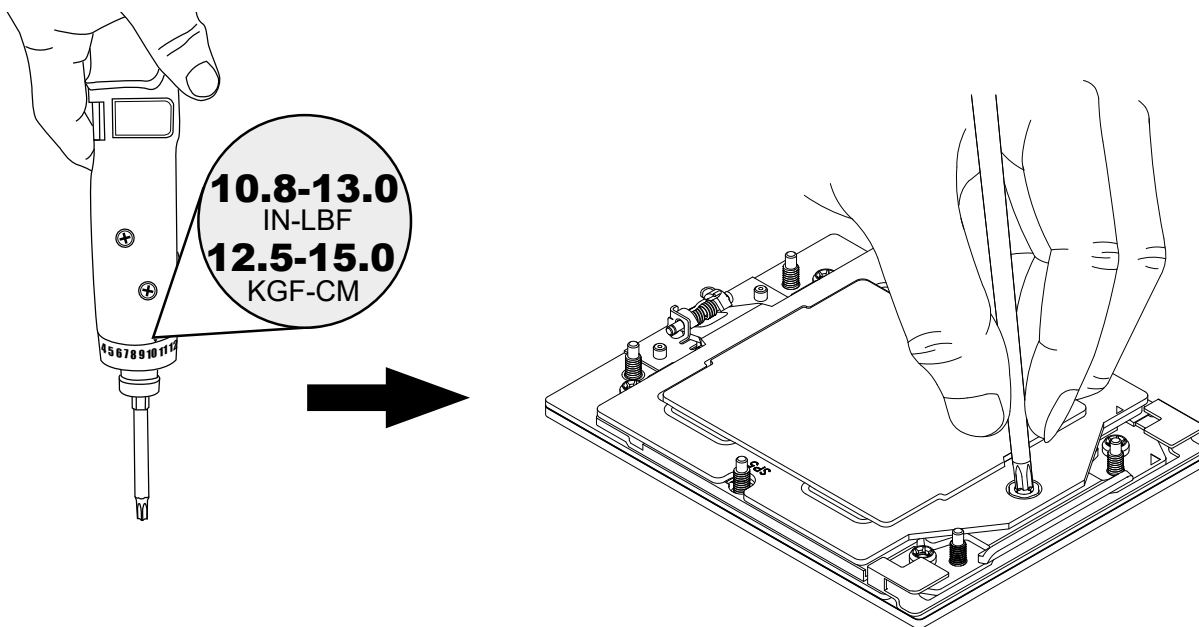

10. Replace and tighten the screws in the same order you removed them. When finished, the force frame will be secure over both the rail frame and CPU package.

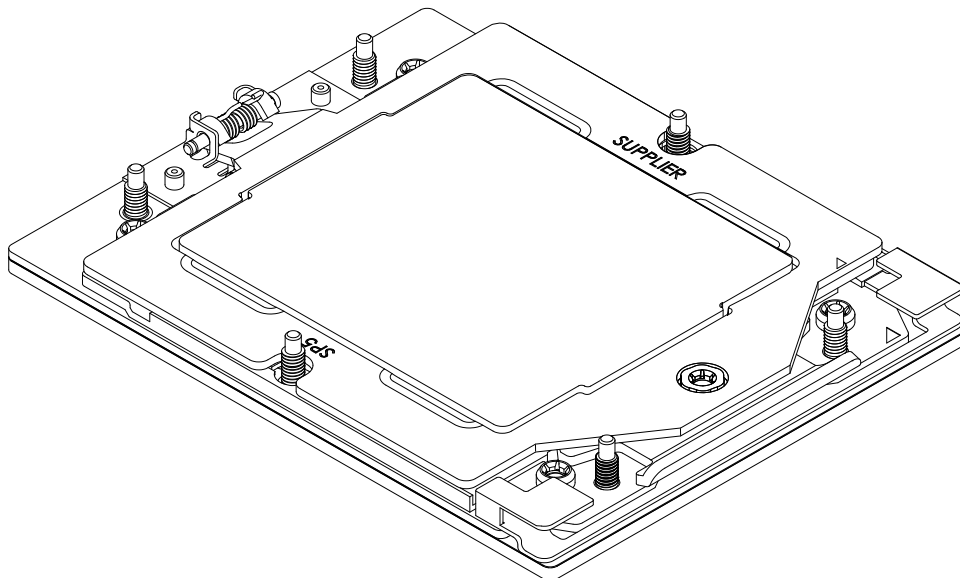

11. After the force frame is secured and the CPU package is in place, now you must install the heatsink to the frame. Lower the heatsink down till it rests securely over the six screw holes on CPU package on the socket frame.

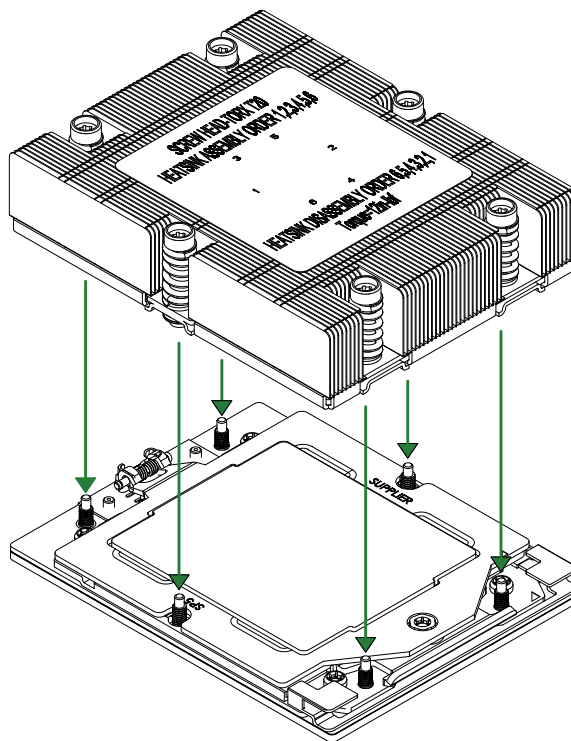

- Using a diagonal pattern, tighten the six screws down on the heatsink in a clockwise fashion till it is secure. The heatsink will now be secured and you have finished installing the processor and heatsink onto the motherboard. Repeat this procedure for any remaining CPU sockets on the motherboard.

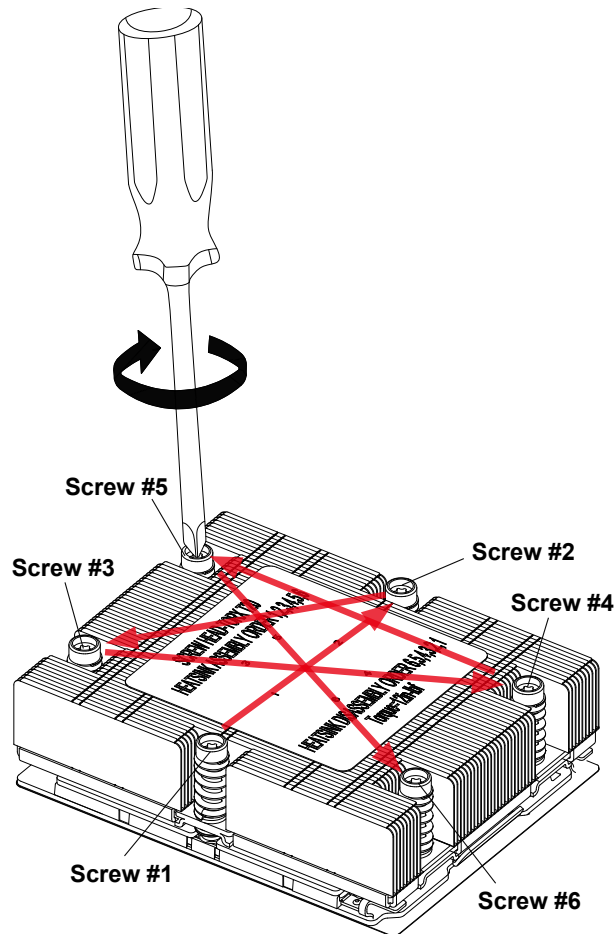

### **Removing the Processor and Heatsink**

1. Remove the heatsink attached to the top of the CPU package by reversing the installation procedure.
2. Clean the thermal grease left by the heatsink on the CPU package lid to limit the risk of it contaminating the CPU package land pads or contacts in the socket housing.
3. Unscrew the plate and lift the force frame to the vertical position.
4. Lift the rail frame using the lift tabs near the front end of the rail frame. Note that the rail frame is spring loaded, so be careful lifting it up into a vertical position.
5. Grip the handle of the carrier frame and pull upwards to extract it from the rail frame. Return the carrier frame/CPU package to its original shipping container.
6. Grip the handle on the external cap and return it to the rail frame sliding it downwards till it rests in the frame.
7. Grip the rail frame, rotate it downwards till it rests above and locks over the socket housing in its horizontal position.
8. Push and rotate down the force frame till it is over the external cap and rail frame into a horizontal position.
9. While holding down the force frame, secure it back to the socket frame by securing screw #1 in place.

## 3.5 Memory

**Note:** Check the Supermicro website for recommended memory modules.

**Important:** Exercise extreme care when installing or removing DIMM modules to prevent any possible damage.

### Memory Support

The H13SST-G supports up to 3 TB DDR5 6400 MT/s ECC DDR5 RDIMM (AMD EPYC™ 9005 Series Processor, MB R2.01), in 12 slots. Refer to the table below for additional memory information.

**Note:** Check the Supermicro website for possible updates to memory support.

DIMM Population Guide												
Type	Channel											
	F1	E1	D1	C1	B1	A1	G1	H1	I1	J1	K1	L1
CPU1 & 1 DIMM						V						
CPU1 & 2 DIMM						V	V					
CPU1 & 4 DIMM				V		V	V		V			
CPU1 & 6 DIMM				V	V	V	V	V	V			
CPU1 & 8 DIMM		V		V	V	V	V	V	V		V	
CPU1 & 10 DIMM		V	V	V	V	V	V	V	V	V	V	
CPU1 & 12 DIMM	V	V	V	V	V	V	V	V	V	V	V	V

Populating RDIMM/RDIMM 3DS DDR5 Memory Modules with AMD EPYC™ 9004 Series Processor			
Type	DIMM Population	Maximum Frequency (MT/s)	
	DIMM1	5600 MT/s Grade DIMM	4800 MT/s Grade DIMM
RDIMM	1R	4800	4800
	2R	4800	4800
3DS RDIMM	2S2R (4 ranks)	4800	4800
	2S4R (8 ranks)	4800	4800

Populating RDIMM/RDIMM 3DS DDR5 Memory Modules with AMD EPYC™ 9005 Series Processor (Motherboard revision 2.0 or above is required)				
Type	DIMM Population	Maximum Frequency (MT/s)		
	DIMM1	6400 MT/s Grade DIMM	5600 MT/s Grade DIMM	4800 MT/s Grade DIMM
RDIMM	1R	6000	5600	4800
	2R	6000	5600	4800
3DS RDIMM	2S2R (4 ranks)	6000	5600	4800
	2S4R (8 ranks)	6000	5600	4800

## DIMM Module Population Sequence

There is no specific order or sequence required when installing memory modules. However do keep the following in mind:

- It is recommended that DDR5 DIMM modules of the same type, size and speed should be installed.
- Mixed DIMM speeds can be installed. However, all DIMMs will run at the speed of the slowest DIMM.
- The motherboard will support odd-numbered modules (1 or 3 modules installed). However, to achieve the best memory performance, fully populate the motherboard with validated memory modules.

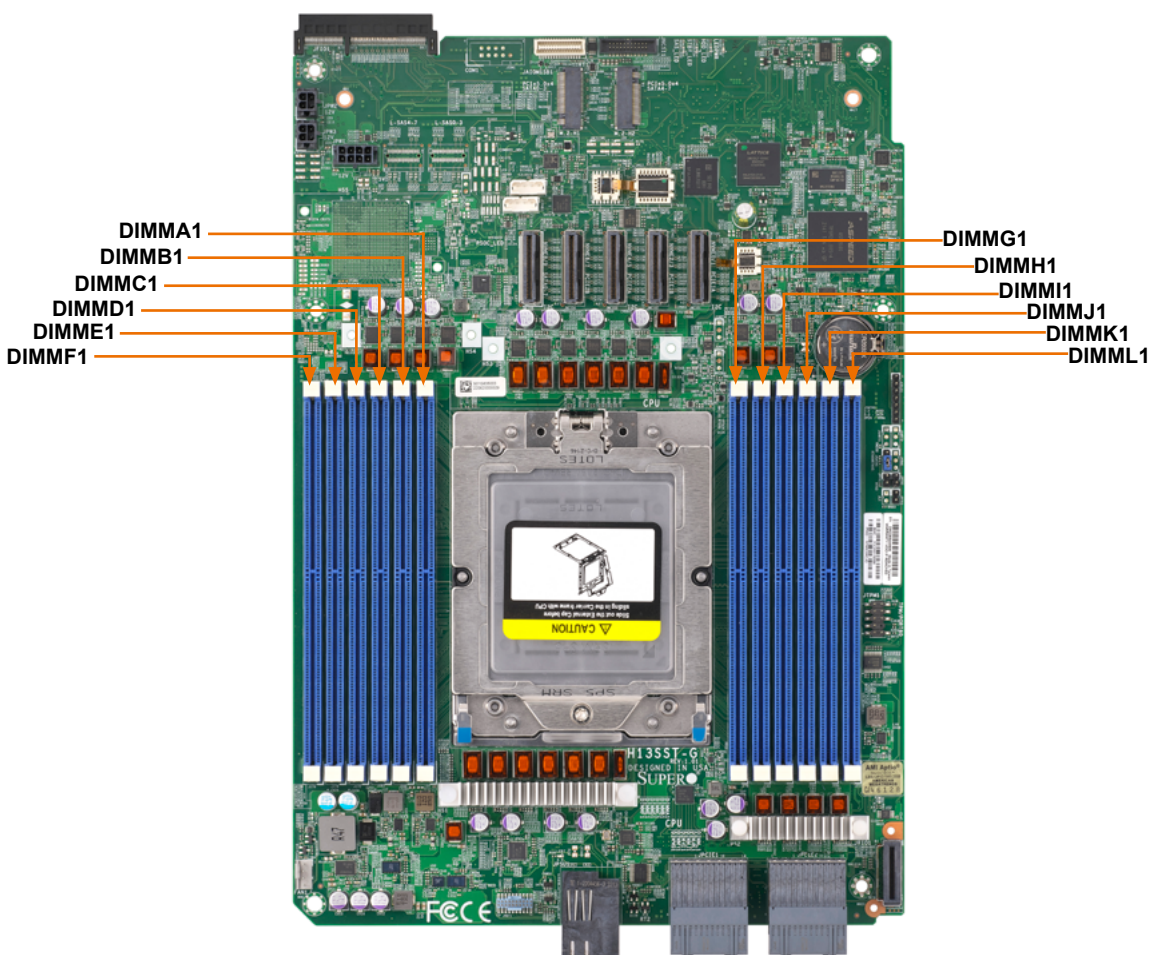
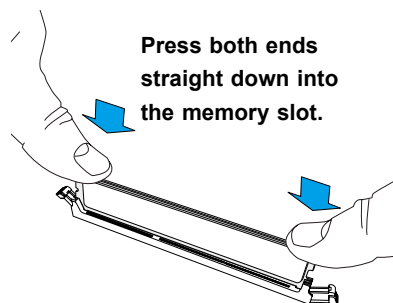
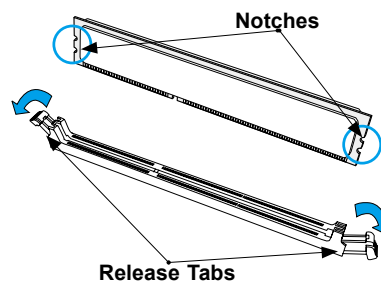
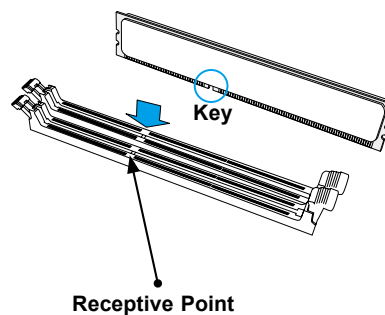

Figure 3-4. DIMM Numbering

## DIMM Installation

1. Insert the desired number of DIMMs into the memory slots, there is no specific sequence or order required.
2. Push the release tabs outwards on both ends of the DIMM slot to unlock it.
3. Align the key of the DIMM module with the receptive point on the memory slot.
4. Align the notches on both ends of the module against the receptive points on the ends of the slot.
5. Press both ends of the module straight down into the slot until the module snaps into place.
6. Press the release tabs to the lock positions to secure the DIMM module into the slot.



## DIMM Removal

Press both release tabs on the ends of the DIMM module to unlock it. Once the DIMM module is loosened, remove it from the memory slot.

## Motherboard Battery

The motherboard uses non-volatile memory to retain system information when system power is removed. This memory is powered by a lithium battery residing on the motherboard.

### Replacing the Battery

Begin by removing power from the system as described in [Section 3.1](#).

1. Push aside the small clamp that covers the edge of the battery. When the battery is released, lift it out of the holder.
2. To insert a new battery, slide one edge under the lip of the holder with the positive (+) side facing up. Then push the other side down until the clamp snaps over it.

**Note:** Handle used batteries carefully. Do not damage the battery in any way; a damaged battery may release hazardous materials into the environment. Do not discard a used battery in the garbage or a public landfill. Please comply with the regulations set up by your local hazardous waste management agency to dispose of your used battery properly.

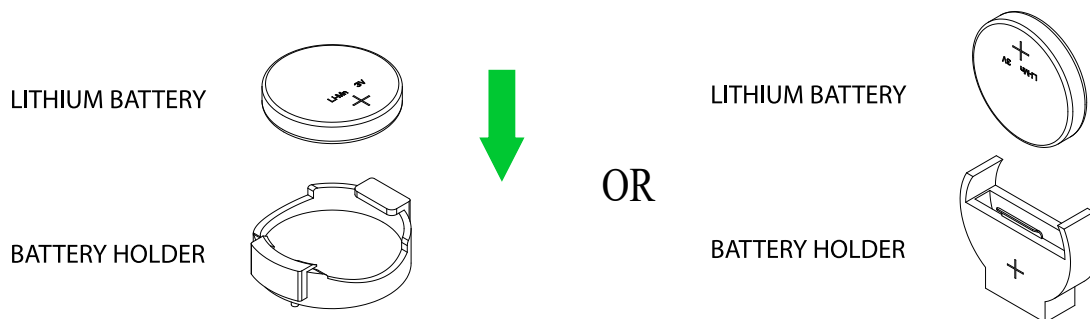

**Figure 3-5. Installing the Onboard Battery**

**Important:** There is a danger of explosion if the onboard battery is installed upside down (which reverses its polarities). This battery must be replaced only with the same or an equivalent type recommended by the manufacturer (CR2032).

## 3.6 Chassis Components

### Storage Drives

The CSE-GT214BF-R2K21BP2 chassis supports up to 16 storage drives (up to four 2.5" drives per node) in drive carriers to simplify their removal from the chassis. These carriers also help promote proper airflow.

To support different storage drive solution, the system needs to install either the SATA enablement kit (MCP-450-21406-ASM) or NVMe enablement kit (MCP-450-21408-ASM). Each above kit supports two drives, and the user can install up to two enablement kits into one node.

### Drive Carrier Indicators

Each drive carrier has two LED indicators: an activity indicator and a status indicator. For RAID configurations using a controller, the meaning of the status indicator is described in the table below. For OS RAID or non-RAID configurations, some LED indications are not supported, such as hot spare.

Drive Carrier LED Indicators			
	Color	Blinking Pattern	Behavior for Device
Activity LED	Blue	Solid On	Idle NVMe drive installed
	Blue	Blinking	I/O activity
	Blue	Off	Idle SATA drive installed
Status LED	Green	Solid Green LED	Safe to remove NVMe device
	Amber	Blinking at 1Hz	Do not remove NVMe device

**Note:** Enterprise level storage drives are recommended for use in Supermicro chassis and servers. For information on recommended HDDs, visit the Supermicro website product pages at [www.supermicro.com/products](http://www.supermicro.com/products).

## Drive Configuration

The CSE-GT214BF-R2K21BP2 chassis contains four separate computing node drawers, each with its own motherboard. Each node controls a set of four drives (optional storage kit required). If a node drawer is pulled out of the chassis, the drives associated with that node will power down.

Node Drawer Locations	
Node B controls drives B0, B1, B2, and B3	Node D controls drives D0, D1, D2, and D3
Node A controls drives A0, A1, A2, and A3	Node C controls drives C0, C1, C2, and C3

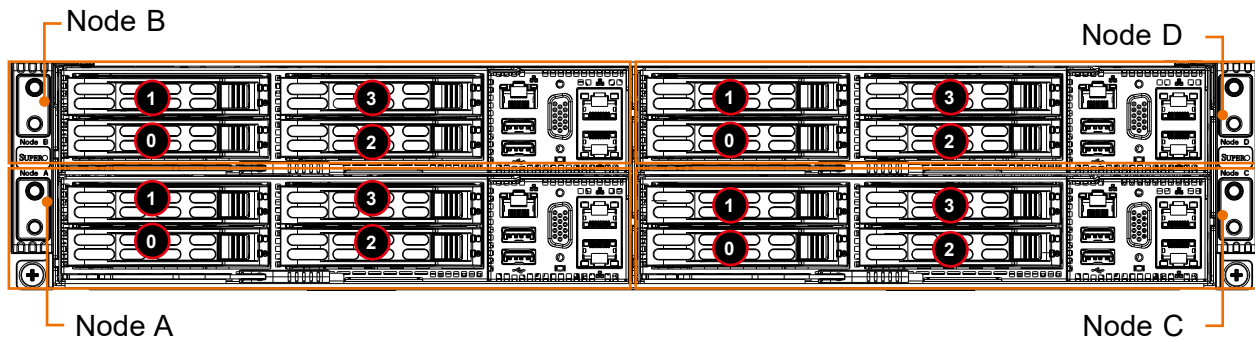

## Removing/Installing Drives

### Removing a Drive Carrier from the Chassis

1. Press the release button on the drive carrier. This extends the drive carrier handle.
2. Use the handle to pull the carrier out of the chassis.

**Caution:** Except for short periods of time (swapping drives), do not operate the server with the drive carriers removed from the bays, regardless of how many drives are installed, for proper airflow.

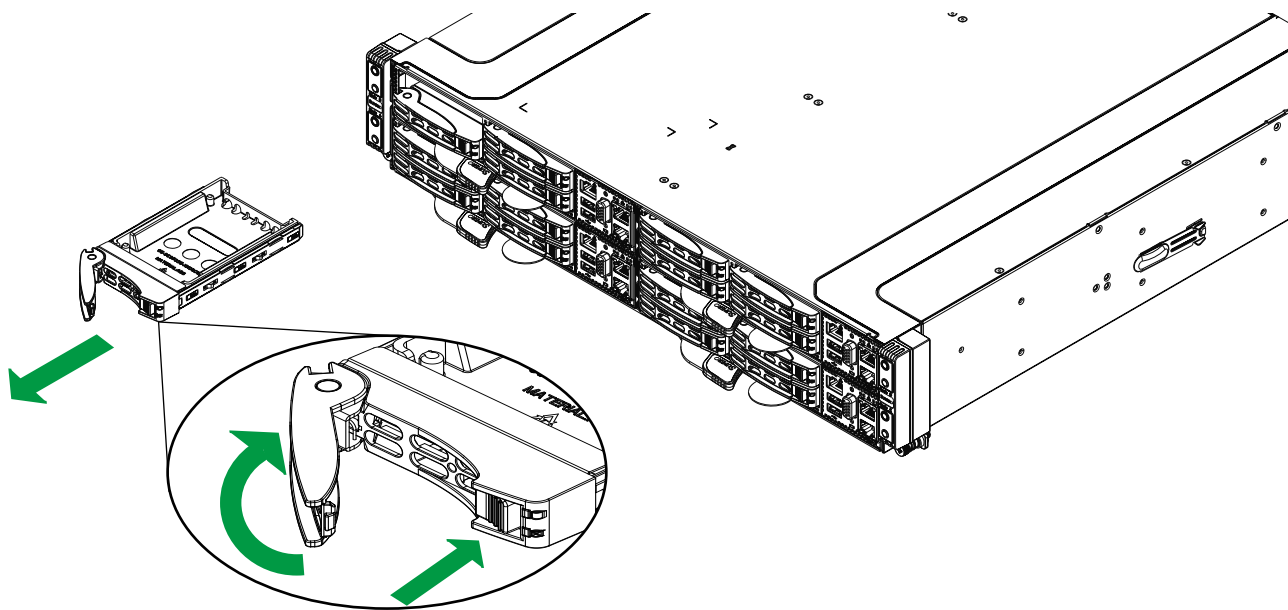

### 2.5" Drive Cage Removal/Installation

If you configured your system with 2.5" drives, the drive cage is mounted inside the node as shown below.

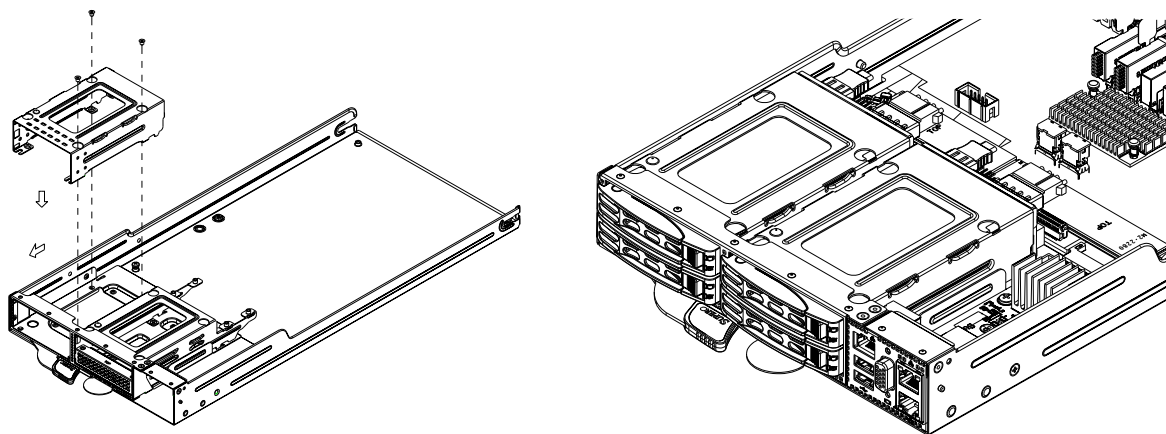
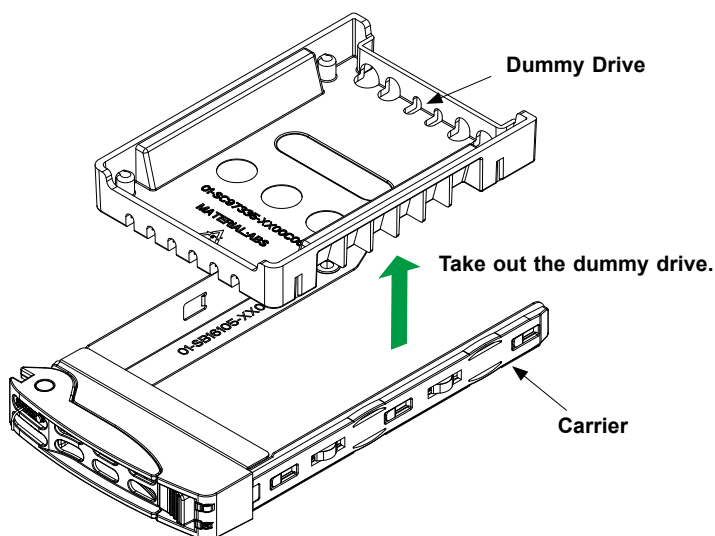

Figure 3-6. Removing a Drive Carrier

### Installing a 2.5" Drive

1. Place the drive carrier on a flat surface.
2. Remove the dummy drive, which comes pre-installed in the drive carrier, by removing the two locking tabs securing the dummy drive to the carrier.
3. Lift the dummy drive up and out of the carrier.



**Figure 3-7. Removing a Dummy Drive from the Drive Carrier**

4. Insert a new drive into the carrier with the printed circuit board side facing downward and the connector oriented at the rear of the carrier.
5. Align the drive in the carrier so that the mounting holes in the drive align with the mounting holes in the carrier. Note that there are holes in the carrier marked "SATA" to aid in correct installation of the drive.
6. Secure the drive to the carrier with the two locking tabs.

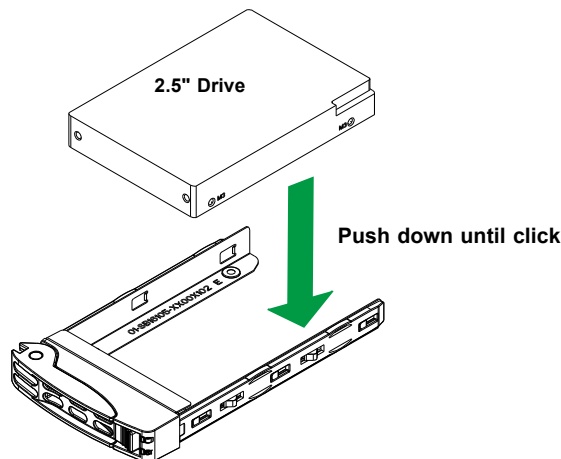

**Figure 3-8. Securing the HDD**

7. Insert the drive carrier into the chassis drive bay, keeping the carrier oriented so that the drive is on the top of the carrier and the release button is on the right side. When the carrier reaches the back of the drive bay, the release handle will retract.
8. Push the handle in until the drive carrier clicks into the locked position.

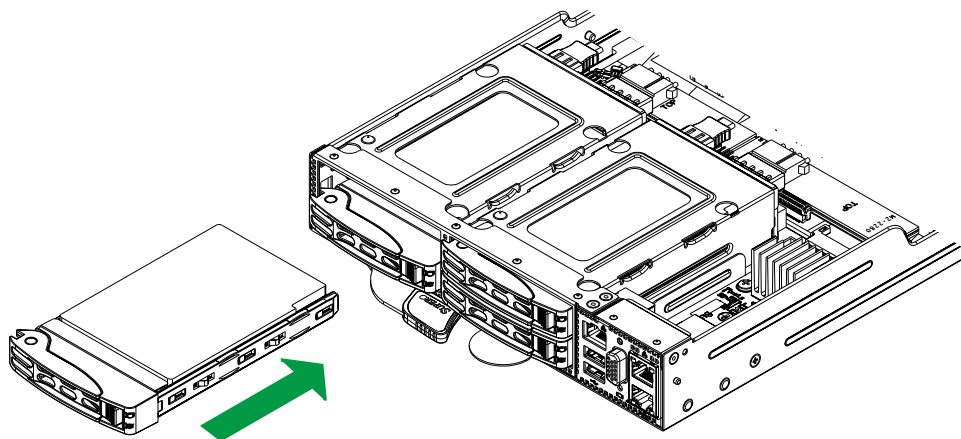

### ***Removing a 2.5" Drive***

1. After removing the carrier from the system, push up from the bottom of the drive to remove it from the carrier.
2. Replace with a new drive and insert the carrier back into the open drive bay.

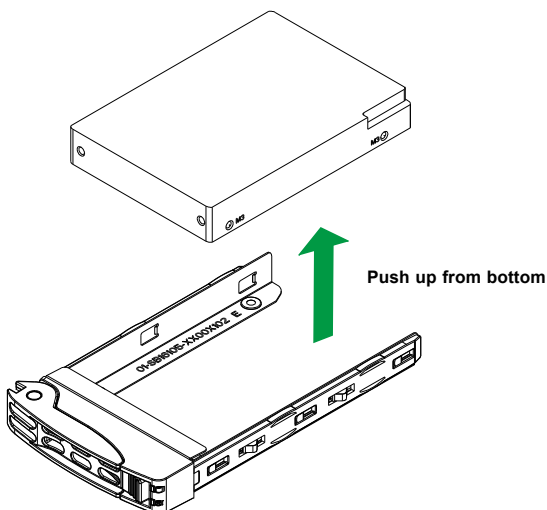

## Hot-Swap for NVMe Drives

Supermicro servers support NVMe surprise hot-swap. For even better data security, NVMe *orderly* hot-swap is recommended. NVMe drives can be ejected and replaced remotely using BMC.

### Ejecting a Drive

1. **BMC > System > Storage Monitoring > Physical View**
2. Select Device, Group and Slot, and click **Eject**. After ejecting, the drive Status LED indicator turns green.
3. Remove the drive.

Note that *Device* and *Group* are categorized by the CPLD design architecture. The AS -2115GT-HNTF server has one Device and one Group.

*Slot* is the slot number on which the NVMe drives are mounted.

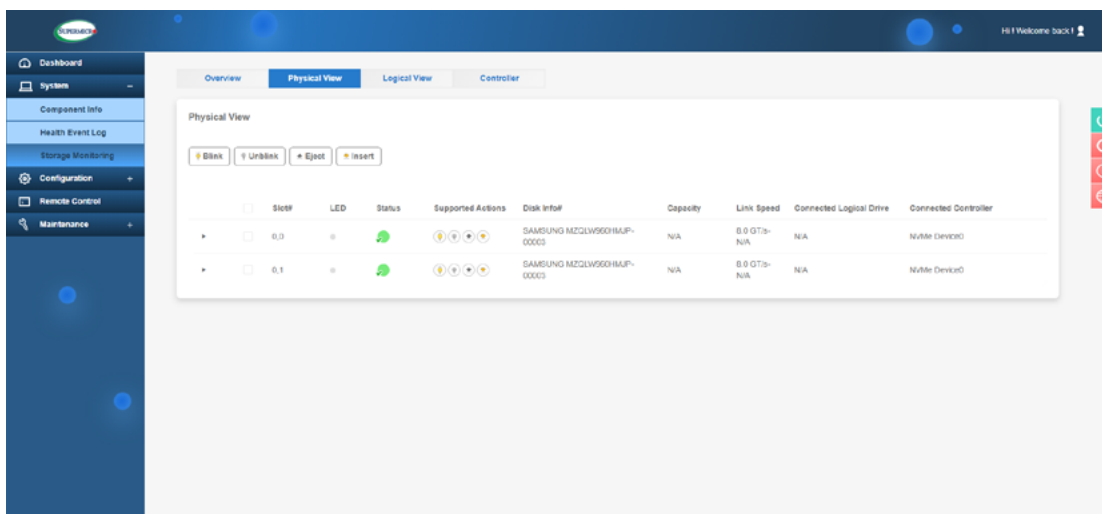

Figure 3-9. BMC Screenshot

### Replacing the Drive

1. Insert the replacement drive.
2. **BMC > System > Storage Monitoring > Physical View**
3. Select Device, Group and slot and click **Insert**. The drive Status LED indicator flashes red, then turns off. The Activity LED turns blue.

### ***Checking the Temperature of an NVMe Drive***

There are two ways to check using BMC.

#### ***Checking a Drive***

- **BMC > Storage Monitoring > Physical View** – Shows the temperatures of all NVMe drives.
- **BMC > Sensor Reading** – Shows the single highest temperature among all the NVMe drives.

### **AIOM Card**

The Supermicro Advanced Input/Output Module (AIOM) card provides options for network connection. It is inserted into an AIOM slot on the motherboard tray (optional AIOM kit required).

#### ***Removing the AIOM Card***

1. Press the release tab and loosen the thumbscrew on the AIOM card.
2. Grasp the release tab and the thumbscrew and pull the AIOM out of the motherboard tray.

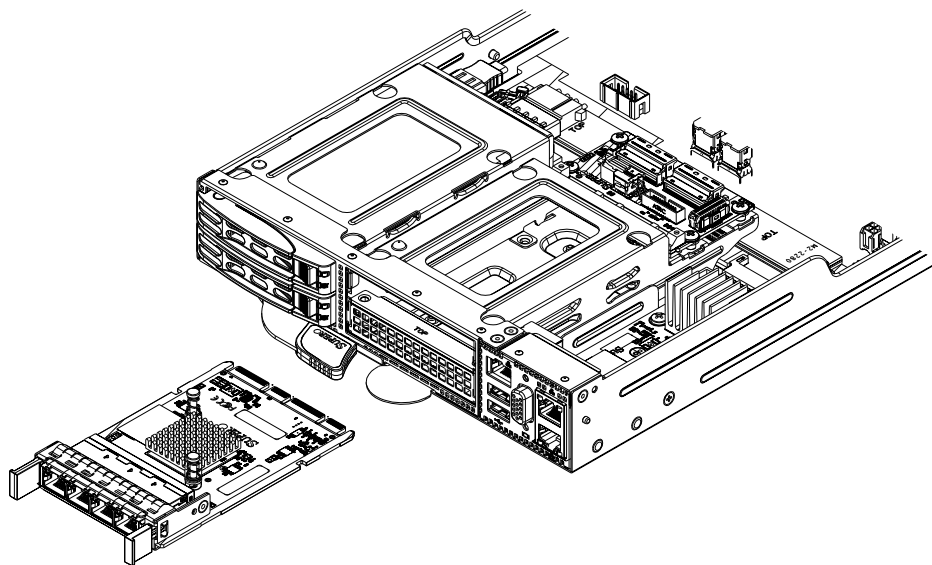

**Figure 3-10. AIOM Card Position**

#### ***Installing the AIOM Card***

1. Insert the AIOM card into the motherboard tray slot as shown until the release tab retracts.
2. Tighten the thumbscrew.

## I/O Card

The I/O card provides options for input/output connections for different devices. It is inserted into the I/O slot on the motherboard tray.

### ***Removing the I/O Card***

1. Loosen and remove the screw on the right side of the motherboard tray.
2. Gently pull the I/O card out of the motherboard tray.

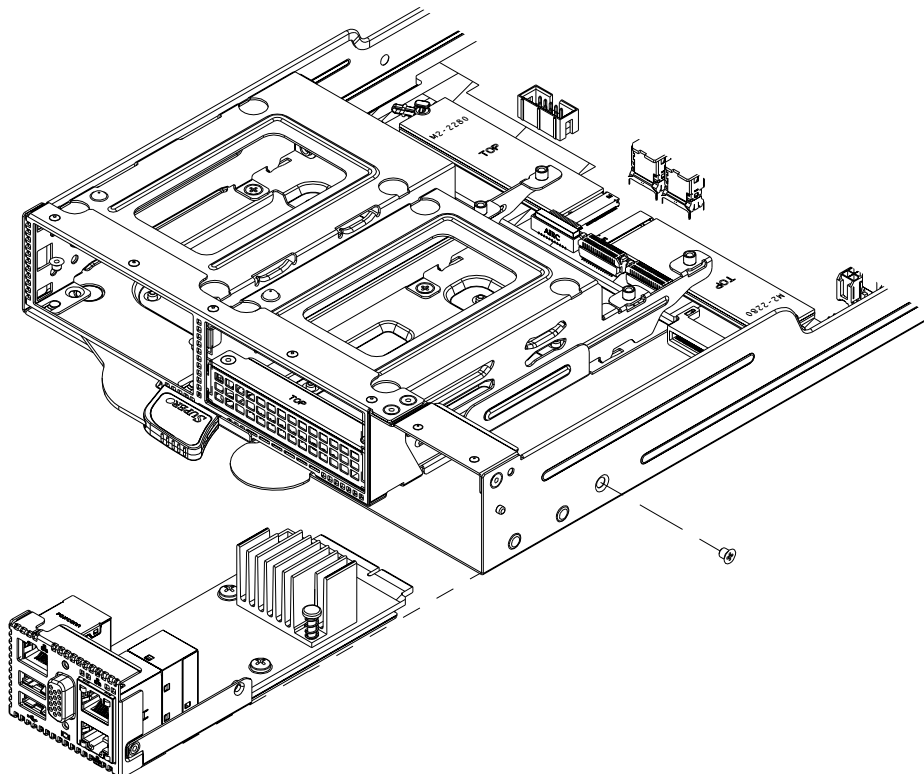

**Figure 3-11. I/O Card Position at Rear**

### ***Installing the I/O Card***

1. Insert the I/O card into the motherboard tray.
2. Install and tighten the screw on the side of the motherboard tray.

## 3.7 System Cooling

### Fans

Fan speed is controlled by a system temperature setting in BMC. If a fan fails, the remaining fans will ramp up to full speed. Replace any failed fan at your earliest convenience with the same type and model.

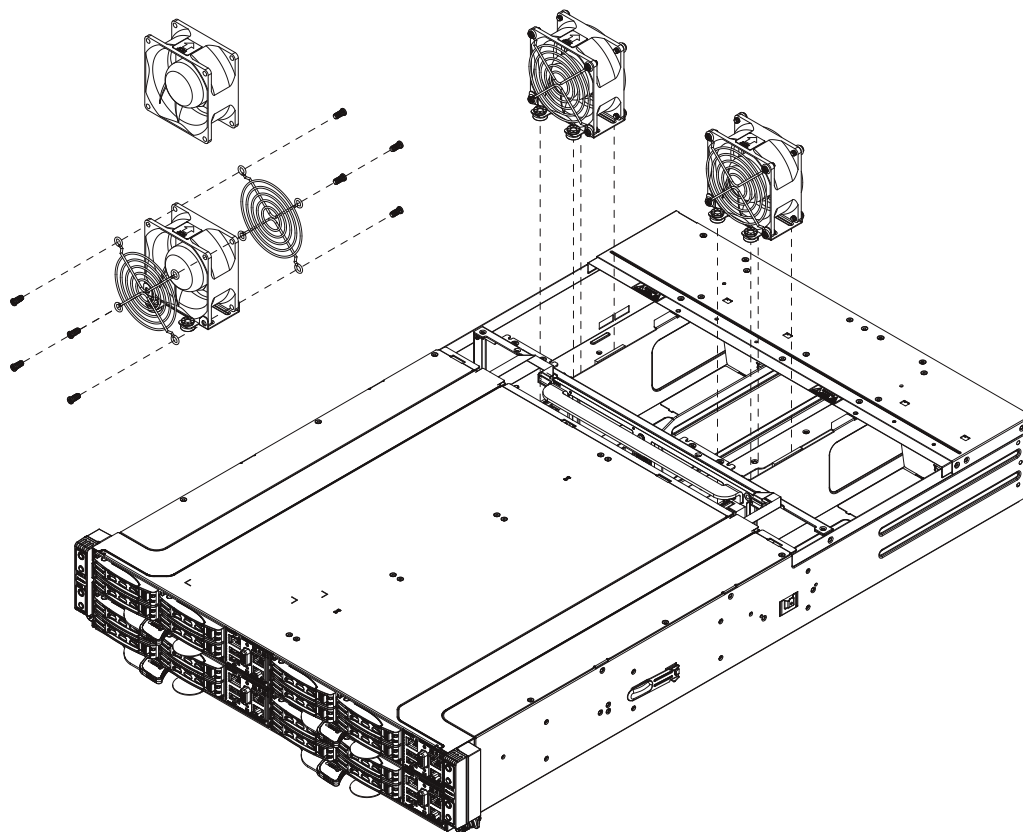

**Figure 3-12. Removing System Fans**

#### ***Changing a System Fan***

1. Determine which fan is failing. If possible, use BMC. If not, remove the chassis cover while the power is on, and examine the fans to determine which one has failed.
2. Remove power from the system as described in [Section 3.1](#).
3. Remove the fan cable from the midplane for the failed fan.
4. Lift the fan housing up and out of the chassis.
5. Push the fan up from the bottom.
6. Put the new fan back into the chassis and reconnect the cable.
7. Power on the system to confirm that the fan is working properly before replacing the chassis cover.

## Installing the Air Shroud

The system requires air shrouds for each node to maximize airflow efficiency. The motherboard, any expansion cards, and all components must be installed in the node tray. Place the air shroud as pictured and secure with the screws.

### *Installing the Air Shroud*

1. First, ensure the CPU, CPU heatsinks, and configured DIMMs are installed.
2. Align the mountings screw holes in the plastic air shroud with those in the node interior and lower the air shroud into the node until it is firmly seated.
3. Secure the air shroud with the two tall standoffs provided. Be careful that the air shroud legs at either end do not interfere with any motherboard components such as cables.
4. Secure the cable protector with the two screws tightened on top of the two tall standoffs in order to cover or manage any loose cables that interfere with the air shroud placement.

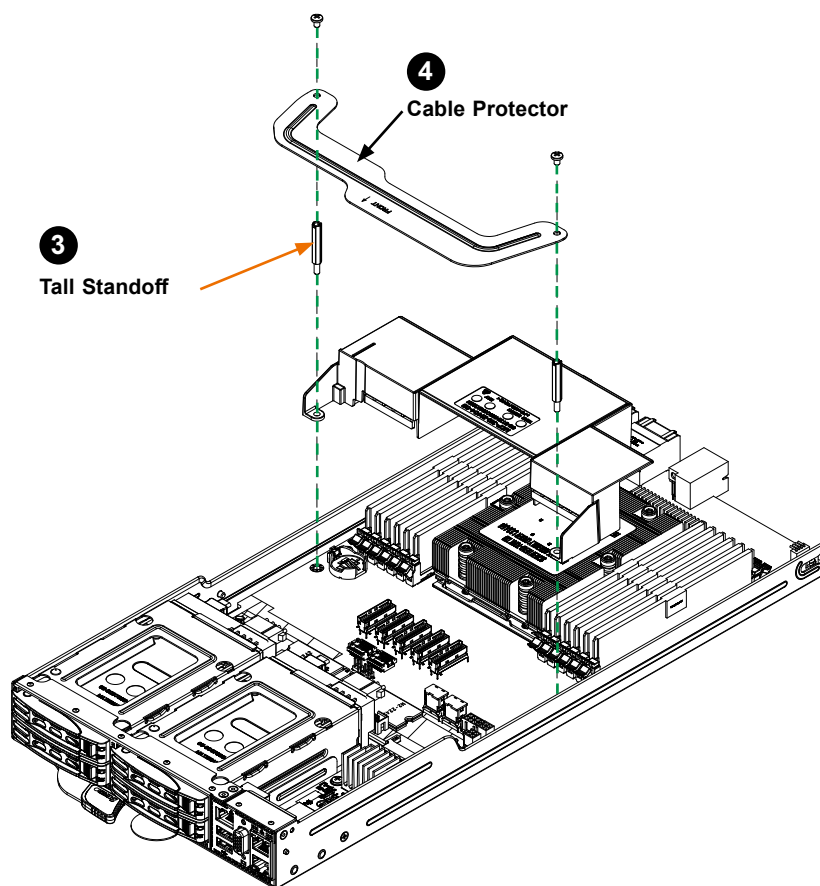

Figure 3-13. Installing the Air Shroud

## 3.8 Power Supply

The chassis features dual redundant and hot-swap power supplies. Please exchange the power modules within one minute. New units can be ordered directly from Supermicro or authorized distributors.

These power supplies are auto-switching capable. This feature enables them to automatically sense the input voltage and operate at a 100-120 v or 180-240 v. An amber light will be illuminated on the power supply when the power is off. An illuminated green light indicates that the power supply is operating.

### ***Replacing the Power Supply***

1. Unplug the AC cord from the module to be replaced.
2. Release the locking clip to unlock the power supply module
3. Pull out the locking lever and remove the unit. To release the lever, squeeze the two metal plates of the lever with your thumb and fingers, and then pull the module out.
4. Replace the failed power module with the same model.

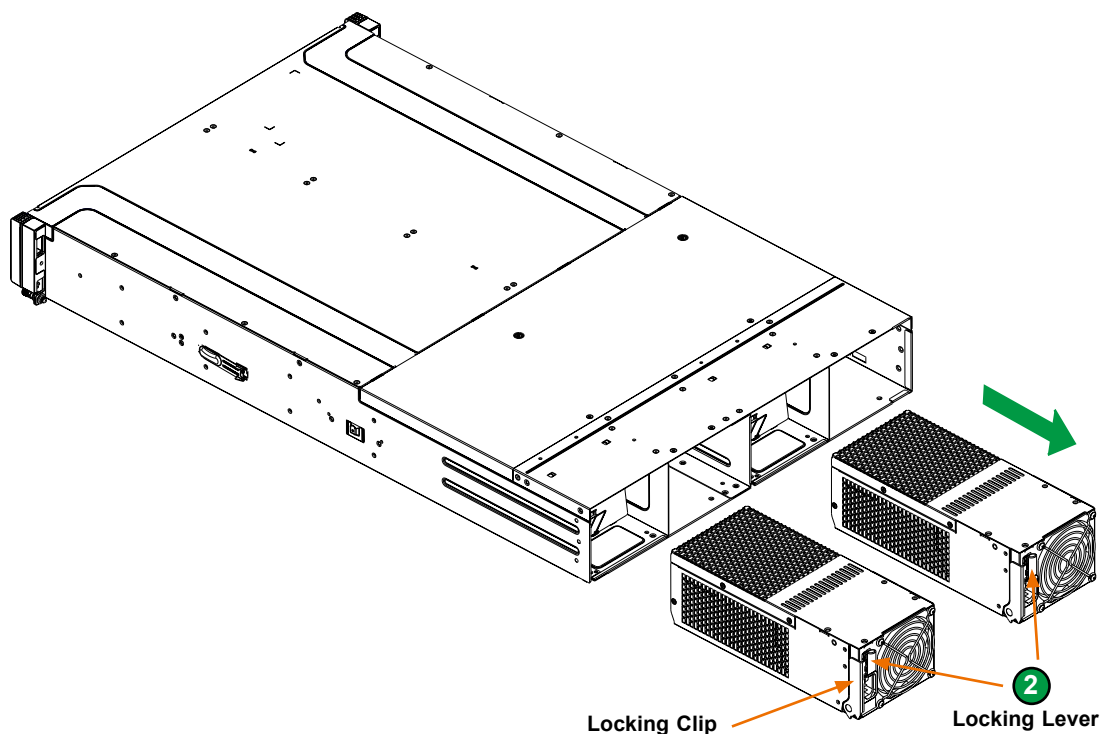

**Figure 3-14. Power Supply Release Tab**

5. Push the new power supply module into the power bay until it clicks.
6. Plug the AC power cord back into the module.

## 3.9 BMC Reset

The BMC can be reset using the button on the front control panel or on the chassis rear.

- Reset – Press and hold the button. After six seconds, the LED blinks at 2 Hz. The BMC resets and the reset duration is ~250 ms. Then the BMC starts to boot.
- Restore factory default configuration – Hold the button for twelve seconds. The LED blinks at 4 Hz while defaults are configured.

**Note:** All BMC settings including username and password will be removed except the FRU and network settings.

BMC Reset Options		
Event	UID LED	BMC Heartbeat LED
Reset	Blue, Blinks at 2 Hz	Green, solid
Restore Defaults	Blue, Blinks at 4 Hz	Green, solid

## Chapter 4

# Motherboard Connections

This section describes the connections, jumpers and LED indicators on the motherboard and provides pinout definitions. Not all connections are required. A motherboard layout indicating component locations may be found in [Chapter 1](#).

Please review the Safety Precautions in [Appendix A](#) before installing or removing components.

### 4.1 Power Connections

#### Power Connectors

JPW1 is the 8-pin power connector for GPU and NVMe power. JPW2 and JPW3 are the 4-pin 12V DC power connectors on the motherboard that provide adequate power supply to your system.

8-pin GPU Power Pin Definitions	
Pin#	Definition
1-4	GND
5-6	12 V
7-8	5 V

4-pin Power Pin Definitions	
Pin#	Definition
1-2	GND
3-4	12 V

## 4.2 Headers and Connectors

### 4-pin External BMC I<sup>2</sup>C Header

A System Management Bus header for IPMI 2.0 is located at JIPMB1. Connect a cable to this header to use the IPMB I<sup>2</sup>C connection on your system. Refer to the table below for pin definitions.

External I <sup>2</sup> C Header Pin Definitions	
Pin#	Definition
1	Data
2	Ground
3	Clock
4	3.3 V

### NC-SI Connector

A Network-Controller Sideband Interface (NC-SI) header is located at JNCSI1 on the motherboard. The NCSI header is used to connect a Network Interface Card (NIC) to the motherboard so that the BMC is able to poll the temperature reading from it.

### TPM/Port 80 Header

A Trusted Platform Module (TPM)/Port 80 header is located at JTPM1 to provide TPM support and Port 80 connection. Use this header to enhance system performance and data security. Refer to the table below for pin definitions. Please go to the following link for more information on the TPM: <http://www.supermicro.com/manuals/other/TPM.pdf>.

Trusted Platform Module Header Pin Definitions			
Pin#	Definition	Pin#	Definition
1	+3.3 V	2	eSPI_CS#
3	RESET#	4	eSPI_MISO
5	eSPI_CLK	6	GND
7	eSPI_MOSI	8	NC
9	+1.8 V Stdby	10	eSPI_IRQ#

## 4.3 Jumper Settings

### How Jumpers Work

To modify the operation of the motherboard, jumpers can be used to choose between optional settings. Jumpers create shorts between two pins to change the function of the connector. Pin #1 is identified with a thicker border line on the printed circuit board. See the diagram below for an example of jumping pins 1 and 2. Refer to the motherboard layout page for jumper locations.

**Note:** On two-pin jumpers, "Closed" means the jumper is on and "Open" means the jumper is off the pins.

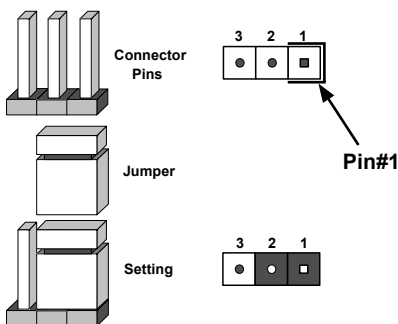

### Clear CMOS (JBT1)

JBT1 is used to clear CMOS, which will also clear any passwords. Instead of pins, this jumper consists of contact pads to prevent accidentally clearing the contents of CMOS.

#### To Clear CMOS

1. First power down the system and unplug the power cord(s).
2. Remove the cover of the chassis to access the motherboard.
3. Remove the CMOS battery from the motherboard.
4. Short the CMOS pads with a metal object such as a small screwdriver for at least four seconds.
5. Remove the screwdriver (or shorting device).
6. Re-install the CMOS battery on the motherboard.
7. Replace the cover, reconnect the power cord(s), and power on the system.

**Note:** Clearing CMOS will also clear all passwords.

Do not use the PW\_ON connector to clear CMOS.



JBT1 contact pads

**JSATA1**

The 3-pin jumper at JSATA1 provides the option to switch the hybrid port (JMCI05) between SATA/NVMe. Refer to the table below for pin definitions.

<b>JSATA1 Pin Definitions</b>	
<b>Pin#</b>	<b>Definition</b>
1-2	Auto (Depends on system configuration)
2-3	SATA
Open	NVMe

## 4.4 LED Indicators

### Onboard Power LED

LED\_PWR is an onboard power LED. When this LED is lit, it means system is in power-on state, and the onboard power status is ok. Turn off the system and unplug the power cord before removing or installing components.

Onboard Power LED Indicator	
LED Color	Definition
Off	System Off (power cable not connected)
Green	System On, Power OK

### BMC Heartbeat LED

A BMC Heartbeat LED is located at LED BMC on the serverboard. When LED BMC is blinking, BMC functions normally. See the table below for more information.

BMC Heartbeat LED States		
Color	State	Definition
Green	Solid On	BMC is not ready.
Green	Blinking	BMC Normal
Green	Fast Blinking	BMC: Initializing

## Chapter 5

### Software

After the hardware has been installed, you can install the Operating System (OS) and install the drivers.

#### 5.1 Microsoft Windows OS Installation

If you will be using RAID, you must configure RAID settings before installing the Windows OS and the RAID driver. Refer to the RAID Configuration User Guides posted on our website at [www.supernmicro.com/support/manuals](http://www.supernmicro.com/support/manuals).

##### *Installing the OS*

1. Create a method to access the Microsoft Windows installation ISO file. That can be a USB flash or media drive.
2. Go to the Supermicro web page for your motherboard and click on "Download the Latest Drivers and Utilities", select the proper driver, and copy it to a USB flash drive.
3. Boot from a bootable device with Windows OS installation. You can see a bootable device list by pressing <F11> during the system startup.

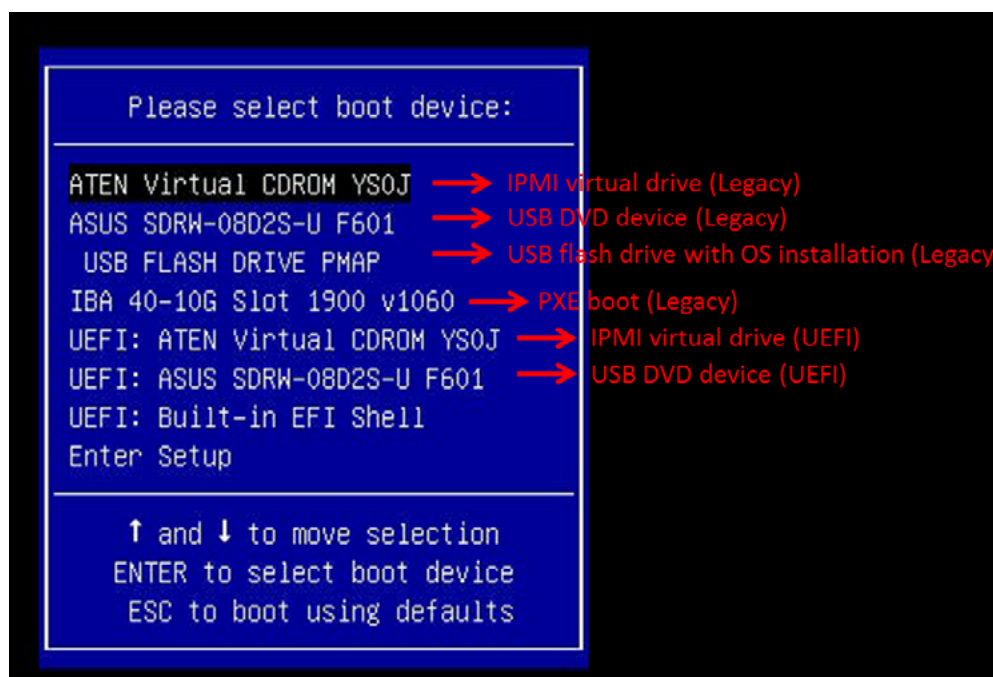
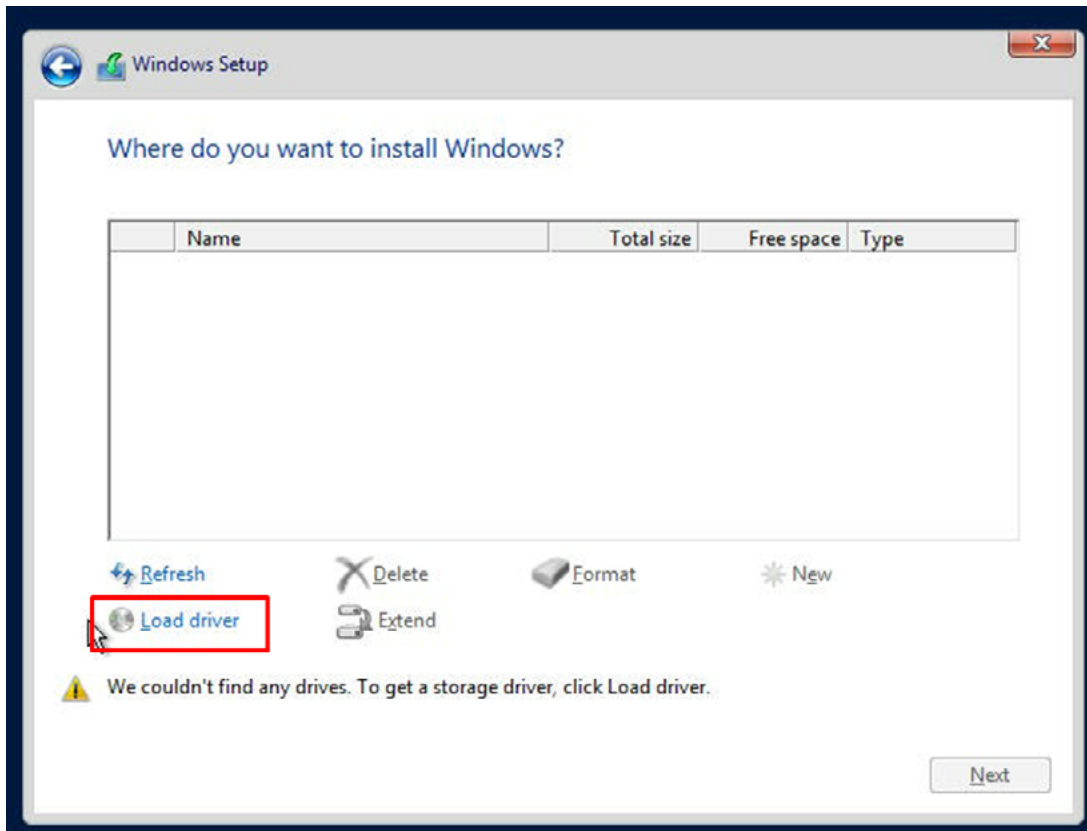

Figure 5-1. Select Boot Device

4. During Windows Setup, continue to the dialog where you select the drives on which to install Windows. If the drive you want to use is not listed, click on “Load driver” link at the bottom left corner.



**Figure 5-2. Load Driver Link**

To load the driver, browse the USB flash drive for the proper driver files.

- For RAID, choose the SATA/sSATA RAID driver indicated then choose the storage drive on which you want to install it.
  - For non-RAID, choose the SATA/sSATA AHCI driver indicated then choose the storage drive on which you want to install it.
5. Once all devices are specified, continue with the installation.
  6. After the Windows OS installation has completed, the system will automatically reboot multiple times.

## 5.2 Driver Installation

The Supermicro website contains drivers and utilities for your system at <https://www.supermicro.com/wdl/>. Some of these must be installed, such as the chipset driver.

After accessing the website, go into the CDR\_Images (in the parent directory of the above link) and locate the ISO file for your motherboard. Download this file to a USB flash or media drive. (You may also use a utility to extract the ISO file if preferred.)

Another option is to go to the Supermicro website at <http://www.supermicro.com/products/>. Find the product page for your motherboard, and "Download the Latest Drivers and Utilities". Insert the flash drive or storage drive and the screenshot shown below should appear.

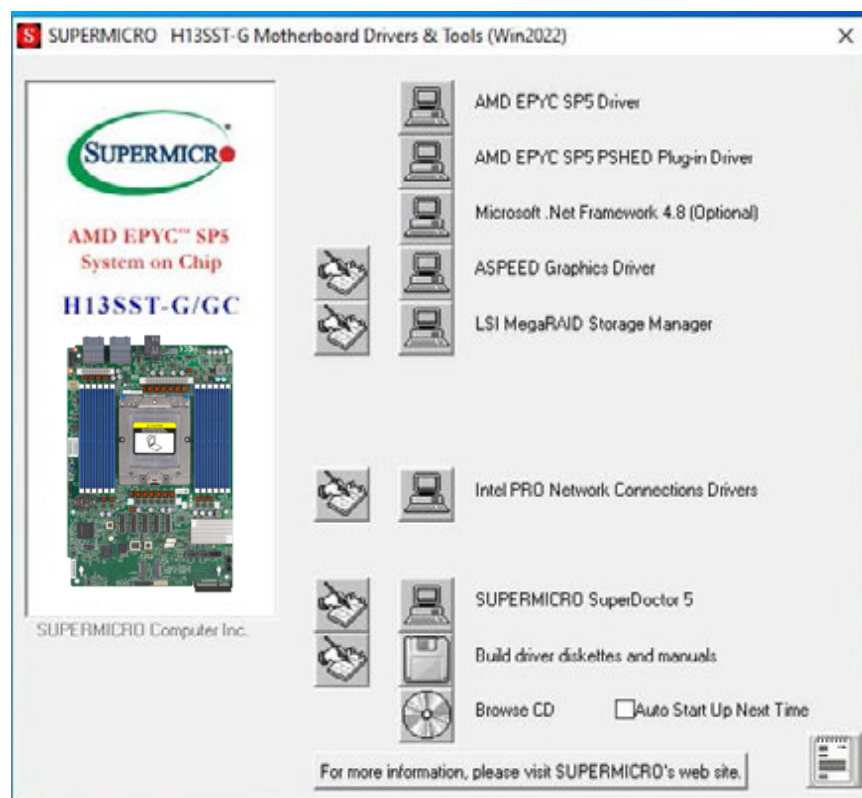

**Figure 5-3. Driver and Tool Installation Screen**

**Note:** Click the icons showing a hand writing on paper to view the readme files for each item. Click the computer icons to the right of these items to install each item (from top to the bottom) one at a time. **After installing each item, you must re-boot the system before moving on to the next item on the list.** The bottom icon with a CD on it allows you to view the entire contents.

## 5.3 SuperDoctor® 5

The Supermicro SuperDoctor 5 is a program that functions in a command-line or web-based interface for Windows and Linux operating systems. The program monitors such system health information as CPU temperature, system voltages, system power consumption, fan speed, and provides alerts via email or Simple Network Management Protocol (SNMP).

SuperDoctor 5 comes in local and remote management versions and can be used with Nagios to maximize your system monitoring needs. With SuperDoctor 5 Management Server (SSM Server), you can remotely control power on/off and reset chassis intrusion for multiple systems with SuperDoctor 5 or IPMI. SuperDoctor 5 Management Server monitors HTTP, FTP, and SMTP services to optimize the efficiency of your operation.

[SuperDoctor® Manual and Resources](#)



Figure 5-4. SuperDoctor 5 Interface Display Screen (Health Information)

## 5.4 IPMI

The H13SST-G supports the Intelligent Platform Management Interface (IPMI). IPMI is used to provide remote access, monitoring and management. There are several BIOS settings that are related to IPMI.

Supermicro ships standard products with a unique password for the BMC ADMIN user. This password can be found on a label on the motherboard.

For general documentation and information on IPMI, please visit our website at: <http://www.supermicro.com/products/nfo/IPMI.cfm>.

# Chapter 6

## Optional Components

This chapter describes alternate configurations and optional system components.

### 6.1 Optional Parts List

Optional Parts List	
Description	
SATA cable	MCP-220-00147-0B, CBL-MCIO-1217REQT4S2-85, CBL-PWEX-0990Y-20, BPN-SAS3-826TQ-B2B
NVMe cable	MCP-220-00167-0B, CBL-MCIO-1218M5-1, CBL-PWEX-1131-20, BPN-NVME5-826N-B2B
AIOM	MCP-220-21404-0N, CBL-OTHR-1115, CBL-MCIO-1218M5-1, AOM-AIOM-2X8-G5
TPM security module: AOM-TPM-9670V	

### 6.2 TPM Security Module

SPI capable TPM 2.0 with Infineon 9670 controller, vertical form factor.

The JTPM1 header is used to connect a Trusted Platform Module (TPM). A TPM is a security device that supports encryption and authentication in hard drives. It enables the motherboard to deny access if the TPM associated with the storage drive is not installed in the system.

Details and installation procedures are at:

<http://www.supermicro.com/manuals/other/TPM.pdf>.

- AOM-TPM-9670V

# Chapter 7

## Troubleshooting and Support

### 7.1 Information Resources

#### Website

A great deal of information is available on the Supermicro [website](#).

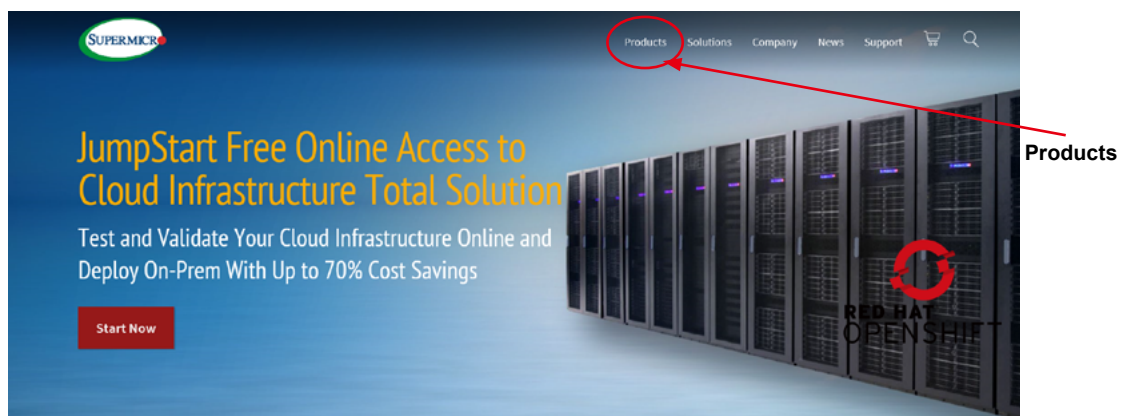

Figure 7-1. Supermicro Website

- Specifications for servers and other hardware are available by clicking the **Products** option.
- The **Support** option offers downloads (manuals, BIOS/BMC, drivers, etc.), FAQs, RMA, warranty, and other service extensions.

#### ***Direct Links for the AS -2115GT-HNTF System***

Web [AS -2115GT-HNTF](#) specifications page

[H13SST-G](#) motherboard page for links to the Quick Reference Guide, User Manual, validated storage drives, etc.

#### ***Direct Links for General Support and Information***

[Frequently Asked Questions](#)

[Add-on card descriptions](#)

[TPM User Guide](#)

[BMC User Guide](#)

[SuperDoctor5 Large Deployment Guide](#)

For validated memory, use our [Product Resources page](#)

## Direct Links (continued)

[Product Matrices](#) page for links to tables summarizing specs for systems, motherboards, power supplies, riser cards, add-on cards, etc.

[Security Center](#) for recent security notices

[Supermicro Phone and Addresses](#)

## 7.2 BMC Interface

The system supports the Baseboard Management Controller (BMC). It provides remote access, monitoring, and management. There are several BIOS settings that are related to BMC.

For general documentation and information on BMC, please visit our website at:

[https://www.supermicro.com/manuals/other/BMC\\_IPMI\\_X13\\_H13.pdf](https://www.supermicro.com/manuals/other/BMC_IPMI_X13_H13.pdf)

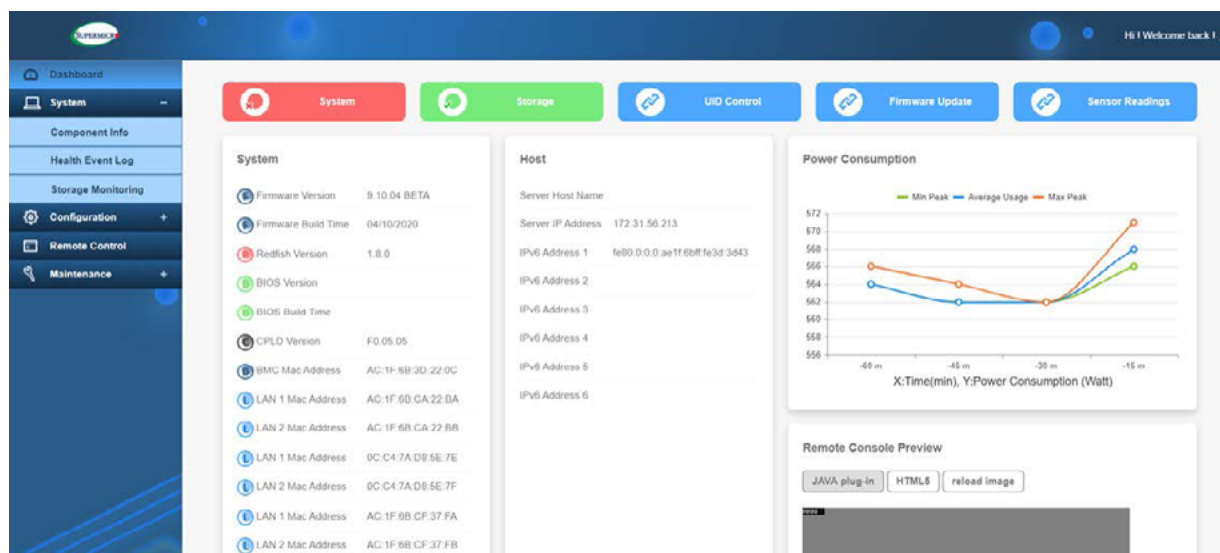

Figure 7-2. BMC Dashboard

## 7.3 Troubleshooting Procedures

Use the following procedures to troubleshoot your system. If you have followed all of the procedures below and still need assistance, refer to the [‘Technical Support Procedures’](#) and/or [‘Returning Merchandise for Service’](#) section(s) in this chapter. Always disconnect the AC power cord before adding, changing or installing any non hot-swappable hardware components.

### Before Power On

1. Check that the Power OK LED on the motherboard is on.
2. Make sure that the power connector is connected to your power supply.
3. Make sure that no short circuits exist between the motherboard and chassis.
4. Disconnect all cables from the motherboard, including those for the keyboard and mouse.
5. Remove all add-on cards.
6. Install a CPU, a heatsink\*, and at least one DIMM on the motherboard. Check all jumper settings properly. \*Make sure that the heatsink is fully seated.
7. Use the correct type of onboard CMOS battery (CR2032) as recommended by the manufacturer. To avoid possible explosion, do not install the CMOS battery upside down.

### No Power

1. Make sure that no short circuits exist between the motherboard and the chassis.
2. Verify that all jumpers are set to their default positions.
3. Turn the power switch on and off to test the system
4. The battery on your motherboard may be old. Check to verify that it still supplies approximately 3 VDC. If it does not, replace it with a new one..

## No Video

1. Check that the VGA cable is connected properly, and the monitor is on.
2. Check if you follow the guidelines to install the memory module (see [DIMM Module Population](#) in Chapter 3).
3. Reseat the memory DIMM modules.

**Note:** If you are a system integrator, VAR or OEM, a POST diagnostics card is recommended.

## System Boot Failure

If the system does not display POST (Power-On-Self-Test) or does not respond after the power is turned on, check the following:

1. Clear the CMOS settings by unplugging the power cord and remove the battery for 30 seconds, refer to [Section 4.3](#).
2. Remove all components from the motherboard, especially the DIMM modules.
3. Turn on the system with only one DIMM module installed. If the system boots, check for bad DIMM modules or slots by following the Memory Errors Troubleshooting procedure in this chapter.

## Memory Errors

1. Make sure that the DIMM modules are properly and fully installed.
2. Confirm that you are using the correct memory. Also, it is recommended that you use the same memory type and speed for all DIMMs in the system. See [Section 3.4](#) for memory details.
3. Check for bad DIMM modules or slots by swapping modules between slots and noting the results.

## The System Cannot Retain the Setup Configuration

1. Make sure that you are using a high quality power supply. A poor quality power supply may cause the system to lose the CMOS setup information. Refer to [Section 3.8](#) for details on power supplies.
2. The battery on your motherboard may be old. Check to verify that it still supplies approximately 3 VDC. If it does not, replace it with a new one.
3. If the above steps do not fix the setup configuration problem, contact your vendor for repairs.

## If the System Becomes Unstable

### **A. If the system becomes unstable during or after OS installation, check the following:**

1. CPU/BIOS support: Make sure that your CPU is supported and that you have the latest BIOS installed in your system.
2. Memory support: Make sure that the memory modules are supported by testing the modules using memtest86 or a similar utility.

**Note:** Refer to the product page at <http://www.supermicro.com> for memory and CPU support and updates.

3. Storage drive support: Make sure that all storage drives work properly. Replace the failed storage drives with good ones.
4. System cooling: Check that all heatsink fans and CPU/system fans, etc., are working properly. Check the hardware monitoring settings in the BMC to make sure that the CPU and system temperatures are within the normal range. Also, check that the front panel Overheat LED is not on.
5. Adequate power supply: Make sure that the power supply provides adequate power to the system. And that all power connectors are connected. Refer to our website for more information on the minimum power requirements.
6. Proper software support: Make sure that the correct drivers are used.

### **B. If the system becomes unstable before or during OS installation, check the following:**

1. Source of installation: Make sure that the devices used for installation are working properly, including boot devices such as CD/Media drive.
2. Cable connection: Check that all cables are connected and working properly.
3. Using the minimum configuration for troubleshooting: Remove all unnecessary components (starting with add-on cards first), and use the minimum configuration (but with a CPU and a memory module installed) to identify the trouble areas. Refer to the steps listed in [Section 7.3](#) above for proper troubleshooting procedures.
4. Identifying bad components by isolating them. If necessary, remove a questionable component from the chassis, and test it in isolation to make sure that it works properly. Replace a bad component with a good one.
5. Check and change one component at a time instead of changing several items at the same time. This will help isolate and identify the problem.

6. To find out if a component is good, swap this component with a new one to see if the system will work properly. If so, then the old component is bad. You can also install the questionable component in another system. If the new system works, the component is good and the old system has problems.

## 7.4 Technical Support Procedures

**Before contacting Technical Support, take the following steps.** Also, note that as a motherboard manufacturer, we do not sell directly to end-users, so it is best to first check with your distributor or reseller for troubleshooting services. They should know of any possible problem(s) with the specific system configuration that was sold to you.

1. Review the 'Troubleshooting Procedures' and 'Frequently Asked Questions' (FAQs) sections in this chapter or see the FAQs on our website before contacting Technical Support.
2. BIOS upgrades can be downloaded from our website.

**Note:** Not all BIOS can be flashed depending on the modifications to the boot block code.

3. If you still cannot resolve the problem, include the following information when contacting Supermicro for technical support:
  - Motherboard model and PCB revision number
  - BIOS release date/version (this can be seen on the initial display when your system first boots up)
  - System serial number and configuration

An example of a Technical Support form is posted on our website.

**Distributors:** For immediate assistance, include have your account number when contacting Supermicro technical support through e-mail.

## 7.5 Frequently Asked Questions

**Question: What type of memory does my motherboard support?**

**Answer:** The H13SST-G motherboard supports up to 3 TB 6400 MT/s ECC DDR5 RDIMM (AMD EPYC™ 9005 Series Processor, MB R2.01) in 12 slots.

See [Section 3.5](#) for details on installing memory.

**Question: How do I update my BIOS?**

**Answer:** It is recommended that you **do not** upgrade your BIOS if you are not experiencing any problems with your system. Updated BIOS files are located on our website at <http://www.supermicro.com>. Check the BIOS warning message and information on how to update your BIOS on our website. Select your motherboard model and download the BIOS file to your computer. Also, check the current BIOS revision to make sure that it is newer than your BIOS before downloading. Download the zip file and save the BIOS package to your computer, unzip the BIOS file onto a bootable USB device. Run the batch file using the format FLASH.BAT filename.rom from your bootable USB device to flash the BIOS. Then, your system will automatically reboot.

**Question: Why can't I turn off the power using the momentary power on/off switch?**

**Answer:** The instant power off function is controlled by the Power Button Mode setting in the BIOS. When the On/Off feature is enabled, the motherboard will have instant off capabilities as long as the BIOS has control of the system. When the 4 Seconds Override feature is enabled or when the BIOS is not in control such as during memory count (the first screen that appears when the system is turned on), the momentary on/off switch must be held for more than four seconds to shutdown the system. This feature is required to implement the ACPI features on the motherboard.

## 7.6 Returning Merchandise for Service

A receipt or invoice copy marked with the date of purchase is required before any warranty service will be rendered. Obtain service by calling your vendor for a Returned Merchandise Authorization (RMA) number. When returning to the manufacturer, the RMA number should be prominently displayed on the outside of the shipping carton and mailed prepaid or hand-carried. Shipping and handling charges will be applied for all orders that must be mailed when service is complete.

For faster service, RMA authorizations may be requested online (<http://www.supermicro.com/support/rma/>).

This warranty only covers normal consumer use and does not cover damages incurred in shipping or from failure due to the alteration, misuse, abuse or improper maintenance of products.

During the warranty period, contact your distributor first for any product problems.

## 7.7 Battery Removal and Installation

### Battery Removal

***To remove the onboard battery, follow the steps below:***

1. Power off your system and unplug your power cable.
2. Locate the onboard battery (see Figure 7-3).
3. Using a tool such as a pen or a small screwdriver, push the battery lock outwards to unlock it. Once unlocked, the battery will pop out from the holder.
4. Remove the battery.

## Proper Battery Disposal

Handle used batteries carefully. Do not damage the battery in any way; a damaged battery may release hazardous materials into the environment. Do not discard a used battery in the garbage or a public landfill. Comply with the regulations set up by your local hazardous waste management agency to dispose the used battery properly.

## Battery Installation

1. To install an onboard battery, follow steps 1 and 2 in the Battery Removal section and continue below:
2. Identify the battery's polarity. The positive (+) side should be facing up.
3. Insert the battery into the battery holder and push it down until you hear a click to ensure that the battery is securely locked.

**Important:** When replacing a battery, be sure to only replace it with the same type.

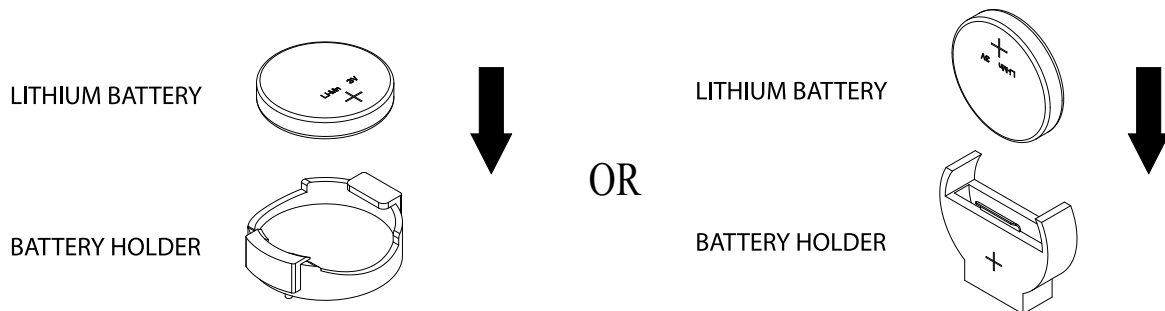

**Figure 7-3. Battery Installation**

## 7.8 BMC Reset

The BMC can be reset using the UID button.

- Reset – Press and hold the UID button. After six seconds, the LED blinks at 2 Hz. The BMC resets and the reset duration is approximately 250 ms. Then the BMC starts to boot.
- Restore factory default configuration – Hold the UID button for twelve seconds. The LED blinks at 4 Hz while defaults are configured. **Note:** All BMC settings including username and password will be removed except the FRU and network settings.

Firmware update – When the BMC firmware is being updated, the UID LED blinks at 10 Hz.

BMC Reset Options		
Event	UID LED	BMC Heartbeat LED
Reset	Blue, Blinks at 2 Hz	Green, solid
Restore Defaults	Blue, Blinks at 4 Hz	Off
Update	Blue, Blinks at 10 Hz	

## 7.9 Where to Get Replacement Components

If you need replacement parts for your system, to ensure the highest level of professional service and technical support, purchase exclusively from our Supermicro Authorized Distributors/System Integrators/Resellers. A list can be found at: <http://www.supermicro.com/>. Click the "Where to Buy" tab.

## 7.10 Reporting an Issue

### Technical Support Procedures

Before contacting Technical Support, please take the following steps. If your system was purchased through a distributor or reseller, please contact them for troubleshooting services. They have the best knowledge of your specific system configuration.

1. Please review the Troubleshooting Procedures in this manual and Frequently Asked Questions on our website of your specific system configuration.
2. BIOS upgrades can be downloaded from our website. **Note:** Not all BIOS can be flashed depending on the modifications to the boot block code.
3. If you still cannot resolve the problem, include the following information when contacting Supermicro for technical support:
  - System, motherboard, and chassis model numbers and PCB revision number
  - BIOS release date/version (This can be seen on the initial display when your system first boots up.)
  - System configuration

An example of a Technical Support form is posted on our website.

**Distributors:** For immediate assistance, please have your account number ready when contacting our technical support department by email.

### Vendor Support Filing System

For issues related to Intel, use the Intel IPS filing system:

<https://www.intel.com/content/www/us/en/design/support/ips/training/welcome.html>

For issues related to Red Hat Enterprise Linux, since it is a subscription based OS, contact your account representative.

## 7.11 Feedback

Supermicro values your feedback as we strive to improve our customer experience in all facets of our business. Please email us at [techwriterteam@supermicro.com](mailto:techwriterteam@supermicro.com) to provide feedback on our manuals.

## 7.12 Contacting Supermicro

### Headquarters

Address: Super Micro Computer, Inc.  
980 Rock Ave.  
San Jose, CA 95131 U.S.A.

Tel: +1 (408) 503-8000

Fax: +1 (408) 503-8008

Email: [marketing@supermicro.com](mailto:marketing@supermicro.com) (General Information)  
[Sales-USA@supermicro.com](mailto:Sales-USA@supermicro.com) (Sales Inquiries)  
[Government\\_Sales-USA@supermicro.com](mailto:Government_Sales-USA@supermicro.com) (Gov. Sales Inquiries)  
[support@supermicro.com](mailto:support@supermicro.com) (Technical Support)  
[RMA@supermicro.com](mailto:RMA@supermicro.com) (RMA Support)  
[Webmaster@supermicro.com](mailto:Webmaster@supermicro.com) (Webmaster)

Website: [www.supermicro.com](http://www.supermicro.com)

### Europe

Address: Super Micro Computer B.V.  
Het Sterrenbeeld 28, 5215 ML  
's-Hertogenbosch, The Netherlands

Tel: +31 (0) 73-6400390

Fax: +31 (0) 73-6416525

Email: [Sales\\_Europe@supermicro.com](mailto:Sales_Europe@supermicro.com) (Sales Inquiries)  
[Support\\_Europe@supermicro.com](mailto:Support_Europe@supermicro.com) (Technical Support)  
[RMA\\_Europe@supermicro.com](mailto:RMA_Europe@supermicro.com) (RMA Support)

Website: [www.supermicro.nl](http://www.supermicro.nl)

### Asia-Pacific

Address: Super Micro Computer, Inc.  
3F, No. 150, Jian 1st Rd.  
Zhonghe Dist., New Taipei City 235  
Taiwan (R.O.C)

Tel: +886-(2) 8226-3990

Fax: +886-(2) 8226-3992

Email: [Sales-Asia@supermicro.com.tw](mailto:Sales-Asia@supermicro.com.tw) (Sales Inquiries)  
[Support@supermicro.com.tw](mailto:Support@supermicro.com.tw) (Technical Support)  
[RMA@supermicro.com.tw](mailto:RMA@supermicro.com.tw) (RMA Support)

Website: [www.supermicro.com.tw](http://www.supermicro.com.tw)

## Appendix A

# Standardized Warning Statements for AC Systems

### About Standardized Warning Statements

The following statements are industry standard warnings, provided to warn the user of situations which have the potential for bodily injury. Should you have questions or experience difficulty, contact Supermicro's Technical Support department for assistance. Only certified technicians should attempt to install or configure components.

Read this appendix in its entirety before installing or configuring components in the Supermicro chassis.

These warnings may also be found on our website at [http://www.supermicro.com/about/policies/safety\\_information.cfm](http://www.supermicro.com/about/policies/safety_information.cfm).

### Warning Definition



**Warning!** This warning symbol means danger. You are in a situation that could cause bodily injury. Before you work on any equipment, be aware of the hazards involved with electrical circuitry and be familiar with standard practices for preventing accidents.

#### 警告の定義

この警告サインは危険を意味します。

人身事故につながる可能性がありますので、いずれの機器でも動作させる前に、電気回路に含まれる危険性に注意して、標準的な事故防止策に精通して下さい。

此警告符号代表危險。

您正处于可能受到严重伤害的工作环境中。在您使用设备开始工作之前，必须充分意识到触电的危险，并熟练掌握防止事故发生的标准工作程序。请根据每项警告结尾的声明号码找到此设备的安全性警告说明的翻译文本。

此警告符號代表危險。

您正處於可能身體可能會受損傷的工作環境中。在您使用任何設備之前，請注意觸電的危險，並且要熟悉預防事故發生的標準工作程序。請依照每一注意事項後的號碼找到相關的翻譯說明內容。

## Warnung

### WICHTIGE SICHERHEITSHINWEISE

Dieses Warnsymbol bedeutet Gefahr. Sie befinden sich in einer Situation, die zu Verletzungen führen kann. Machen Sie sich vor der Arbeit mit Geräten mit den Gefahren elektrischer Schaltungen und den üblichen Verfahren zur Vorbeugung vor Unfällen vertraut. Suchen Sie mit der am Ende jeder Warnung angegebenen Anweisungsnummer nach der jeweiligen Übersetzung in den übersetzten Sicherheitshinweisen, die zusammen mit diesem Gerät ausgeliefert wurden.

BEWAHREN SIE DIESE HINWEISE GUT AUF.

### INSTRUCCIONES IMPORTANTES DE SEGURIDAD

Este símbolo de aviso indica peligro. Existe riesgo para su integridad física. Antes de manipular cualquier equipo, considere los riesgos de la corriente eléctrica y familiarícese con los procedimientos estándar de prevención de accidentes. Al final de cada advertencia encontrará el número que le ayudará a encontrar el texto traducido en el apartado de traducciones que acompaña a este dispositivo.

GUARDE ESTAS INSTRUCCIONES.

### IMPORTANTES INFORMATIONS DE SÉCURITÉ

Ce symbole d'avertissement indique un danger. Vous vous trouvez dans une situation pouvant entraîner des blessures ou des dommages corporels. Avant de travailler sur un équipement, soyez conscient des dangers liés aux circuits électriques et familiarisez-vous avec les procédures couramment utilisées pour éviter les accidents. Pour prendre connaissance des traductions des avertissements figurant dans les consignes de sécurité traduites qui accompagnent cet appareil, référez-vous au numéro de l'instruction situé à la fin de chaque avertissement.

CONSERVEZ CES INFORMATIONS.

## תקנון הזהרות אזהרה

הזהרות הבאות הן אזהרות על פי תקני התעשייה, על מנת להזהיר את המשתמש מפני חבלה פיזית אפשרית. במידה ויש שאלות או היתקלות בבעיה כלשהי, יש ליצור קשר עם מחלקת תמיכה טכנית של סופרמיקרו. טכנאים מוסמכים בלבד רשאים להתקין או להגדיר את הרכיבים. יש לקרוא את הנספח במלואו לפני התקנת או הגדרת הרכיבים במארזי סופרמיקרו.

اَكْ ف حالة وُكِي اَي تتسبب ف اصابة جسدهُ هذا الزهز عُ خطر! تحذُرُ .  
 قبل اَي تعول على اَي هعدات، كي على علن بالوخاطز ال اُجوة عي الذوائر  
 الكهزبائِة  
 وكي على دراةُ بالووارسات النقااِة لو عُ وقع اَي حادث  
 استخدم رقن الب اِى الو صُص ف هاةُ كل تحذُرُ للعشر تزجوتها

안전을 위한 주의사항

경고!

이 경고 기호는 위험이 있음을 알려 줍니다. 작업자의 신체에 부상을 야기 할 수 있는 상태에 있게 됩니다. 모든 장비에 대한 작업을 수행하기 전에 전기회로와 관련된 위험요소들을 확인하시고 사전에 사고를 방지할 수 있도록 표준 작업절차를 준수해 주시기 바랍니다.

해당 번역문을 찾기 위해 각 경고의 마지막 부분에 제공된 경고문 번호를 참조하십시오

## BELANGRIJKE VEILIGHEIDSINSTRUCTIES

Dit waarschuwings symbool betekent gevaar. U verkeert in een situatie die lichamelijk letsel kan veroorzaken. Voordat u aan enige apparatuur gaat werken, dient u zich bewust te zijn van de bij een elektrische installatie betrokken risico's en dient u op de hoogte te zijn van de standaard procedures om ongelukken te voorkomen. Gebruik de nummers aan het eind van elke waarschuwing om deze te herleiden naar de desbetreffende locatie.

BEWAAR DEZE INSTRUCTIES

## Installation Instructions



**Warning!** Read the installation instructions before connecting the system to the power source.

設置手順書

システムを電源に接続する前に、設置手順書をお読み下さい。

警告

将此系统连接电源前,请先阅读安装说明。

警告

將系統與電源連接前，請先閱讀安裝說明。

**Warnung**

Vor dem Anschließen des Systems an die Stromquelle die Installationsanweisungen lesen.

**¡Advertencia!**

Lea las instrucciones de instalación antes de conectar el sistema a la red de alimentación.

**Attention**

Avant de brancher le système sur la source d'alimentation, consulter les directives d'installation.

יש לקרוא את הוראות התקנה לפני חיבור המערכת למקור מתח.

اقرأ إرشادات التركيب قبل توصيل النظام إلى مصدر للطاقة

시스템을 전원에 연결하기 전에 설치 안내를 읽어주십시오.

**Waarschuwing**

Raadpleeg de installatie-instructies voordat u het systeem op de voedingsbron aansluit.

**Circuit Breaker**

**Warning!** This product relies on the building's installation for short-circuit (overcurrent) protection. Ensure that the protective device is rated not greater than: 250 V, 20 A.

**サーキット・ブレーカー**

この製品は、短絡(過電流)保護装置がある建物での設置を前提としています。

保護装置の定格が250 V、20 Aを超えないことを確認下さい。

**警告**

此产品的短路(过载电流)保护由建筑物的供电系统提供,确保短路保护设备的额定电流不大于250V,20A。

**警告**

此產品的短路(過載電流)保護由建築物的供電系統提供,確保短路保護設備的額定電流不大於250V,20A。

**Warnung**

Dieses Produkt ist darauf angewiesen, dass im Gebäude ein Kurzschluss- bzw. Überstromschutz installiert ist. Stellen Sie sicher, dass der Nennwert der Schutzvorrichtung nicht mehr als: 250 V, 20 A beträgt.

**¡Advertencia!**

Este equipo utiliza el sistema de protección contra cortocircuitos (o sobrecorrientes) del edificio. Asegúrese de que el dispositivo de protección no sea superior a: 250 V, 20 A.

**Attention**

Pour ce qui est de la protection contre les courts-circuits (surtension), ce produit dépend de l'installation électrique du local. Vérifiez que le courant nominal du dispositif de protection n'est pas supérieur à :250 V, 20 A.

מוצר זה מסתמך על הגנה המותקנת במבנים למניעת קצר חשמלי. יש לוודא כי המכשיר המגן מפני הקצר החשמלי הוא לא יותר מ-250VDC, 20A

هذا المنتج يعتمد على معدات الحماية مه الدوائر القصيرة التي تم تثبيتها في المبنى  
تأكد من أن تقييم الجهاز الوقائي ليس أكثر من : 20A, 250V

**경고!**

이 제품은 전원의 단락(과전류)방지에 대해서 전적으로 건물의 관련 설비에 의존합니다. 보호장치의 정격이 반드시 250V(볼트), 20A(암페어)를 초과하지 않도록 해야 합니다.

**Waarschuwing**

Dit product is afhankelijk van de kortsluitbeveiliging (overspanning) van uw elektrische installatie. Controleer of het beveiligde apparaat niet groter gedimensioneerd is dan 250V, 20A.

## Power Disconnection Warning



**Warning!** The system must be disconnected from all sources of power and the power cord removed from the power supply module(s) before accessing the chassis interior to install or remove system components (except for hot-swap components).



### 電源切断の警告

システムコンポーネントの取り付けまたは取り外しのために、シャーシ内部にアクセスするには、システムの電源はすべてのソースから切断され、電源コードは電源モジュールから取り外す必要があります。

### 警告

在你打开机箱并安装或移除内部器件前,必须将系统完全断电,并移除电源线。

### 警告

在您打開機殼安裝或移除內部元件前，必須將系統完全斷電，並移除電源線。

### Warnung

Das System muss von allen Quellen der Energie und vom Netzanschlusskabel getrennt sein, das von den Spg.Versorgungsteilmodulen entfernt wird, bevor es auf den Chassisinnenraum zurückgreift, um Systemsbestandteile anzubringen oder zu entfernen.

### ¡Advertencia!

El sistema debe ser disconnected de todas las fuentes de energía y del cable eléctrico quitado de los módulos de fuente de alimentación antes de tener acceso el interior del chasis para instalar o para quitar componentes de sistema.

### Attention

Le système doit être débranché de toutes les sources de puissance ainsi que de son cordon d'alimentation secteur avant d'accéder à l'intérieur du chassis pour installer ou enlever des composants de système.

אזהרה מפני ניתוק חשמלי

אזהרה!

יש לנתק את המערכת מכל מקורות החשמל ויש להסיר את כבל החשמלי מהספק לפני גישה לחלק הפנימי של המארז לצורך התקנת או הסרת רכיבים.

يجب فصل انظاؤ من جميع مصادر انطاقت وإزانت سهك انكهرباء من وحدة امداد انطاقت قيم

انصل إلى امناطق انداخييت نههيكم نشييج أو إزانت مكنناث الجهاز

경고!

시스템에 부품들을 장착하거나 제거하기 위해서는 새시 내부에 접근하기 전에 반드시 전원 공급장치로부터 연결되어있는 모든 전원과 전기코드를 분리해주어야 합니다.

Waarschuwing

Voordat u toegang neemt tot het binnenwerk van de behuizing voor het installeren of verwijderen van systeem onderdelen, dient u alle spanningsbronnen en alle stroomkabels aangesloten op de voeding(en) van de behuizing te verwijderen

## Equipment Installation



**Warning!** Only authorized personnel and qualified service persons should be allowed to install, replace, or service this equipment.

機器の設置

トレーニングを受け認定された人だけがこの装置の設置、交換、またはサービスを許可されています。

警告

只有经过培训且具有资格的人员才能进行此设备的安装、更换和维修。

警告

只有經過受訓且具資格人員才可安裝、更換與維修此設備。

Warnung

Nur autorisiertes Personal und qualifizierte Servicetechniker dürfen dieses Gerät installieren, austauschen oder warten..

¡Advertencia!

Sólo el personal autorizado y el personal de servicio calificado deben poder instalar, reemplazar o dar servicio a este equipo.

**Attention**

Seul le personnel autorisé et le personnel de maintenance qualifié doivent être autorisés à installer, remplacer ou entretenir cet équipement..

אזהרה!

יש לאפשר רק צוות מורשה ואנשי שירות מוסמכים להתקין, להחליף או לטפל בציוד זה.

ينبغي السماح فقط للموظفين المعتمدين وأفراد الخدمة المؤهلين بتركيب هذا الجهاز أو استبداله أو صيانته.

**경고!**

승인된 직원과 자격을 갖춘 서비스 담당자만이 이 장비를 설치, 교체 또는 서비스할 수 있습니다.

**Waarschuwing**

Alleen geautoriseerd personeel en gekwalificeerd onderhoudspersoneel mag deze apparatuur installeren, vervangen of onderhouden..

**Restricted Area**

**Warning!** This unit is intended for installation in restricted access areas. A restricted access area can be accessed only through the use of a special tool, lock and key, or other means of security. (This warning does not apply to workstations).

**アクセス制限区域**

このユニットは、アクセス制限区域に設置されることを想定しています。

アクセス制限区域は、特別なツール、鍵と錠前、その他のセキュリティの手段を用いてのみ出入りが可能です。

**警告**

此部件应安装在限制进出的场所，限制进出的场所指只能通过使用特殊工具、锁和钥匙或其它安全手段进出的场所。

**警告**

此裝置僅限安裝於進出管制區域，進出管制區域係指僅能以特殊工具、鎖頭及鑰匙或其他安全方式才能進入的區域。

**Warnung**

Diese Einheit ist zur Installation in Bereichen mit beschränktem Zutritt vorgesehen. Der Zutritt zu derartigen Bereichen ist nur mit einem Spezialwerkzeug, Schloss und Schlüssel oder einer sonstigen Sicherheitsvorkehrung möglich.

**¡Advertencia!**

Esta unidad ha sido diseñada para instalación en áreas de acceso restringido. Sólo puede obtenerse acceso a una de estas áreas mediante la utilización de una herramienta especial, cerradura con llave u otro medio de seguridad.

**Attention**

Cet appareil doit être installée dans des zones d'accès réservés. L'accès à une zone d'accès réservé n'est possible qu'en utilisant un outil spécial, un mécanisme de verrouillage et une clé, ou tout autre moyen de sécurité.

אזור עם גישה מוגבלת

אזהרה!

יש להתקין את היחידה באזורים שיש בהם הגבלת גישה. הגישה ניתנת בעזרת 'כלי אבטחה בלבד' (מפתח, מנעול וכד.).

تخصيص هذه انحدة نترك بها ف مناطق محظورة تم .

،مكن اننصل إن منطقت محظورة فقط من خلال استخذاو أداة خاصت أو أ وس هُت أخري نلالأمما ققم ومفتاح

**경고!**

이 장치는 접근이 제한된 구역에 설치하도록 되어있습니다. 특수도구, 잠금 장치 및 키, 또는 기타 보안 수단을 통해서만 접근 제한 구역에 들어갈 수 있습니다.

**Waarschuwing**

Dit apparaat is bedoeld voor installatie in gebieden met een beperkte toegang. Toegang tot dergelijke gebieden kunnen alleen verkregen worden door gebruik te maken van speciaal gereedschap, slot en sleutel of andere veiligheidsmaatregelen.

## Battery Handling



**CAUTION:** There is risk of explosion if the battery is replaced by an incorrect type. Replace the battery only with the same or equivalent type recommended by the manufacturer. Dispose of used batteries according to the manufacturer's instructions

### 電池の取り扱い

バッテリーを間違ったタイプに交換すると爆発の危険があります。交換する電池はメーカーが推奨する型、または同等のものを使用下さい。使用済電池は製造元の指示に従って処分して下さい。

### 警告

如果更换的电池类型不正确，则存在爆炸危险。请只使用同类电池或制造商推荐的功能相当的电池更换原有电池。请按制造商的说明处理废旧电池。

### 警告

如果更換的電池類型不正確，則有爆炸危險。請使用製造商建議之相同或功能相當的電池更換原有電池。請按照製造商的說明指示處理廢棄舊電池。

### WARNUNG

Es besteht Explosionsgefahr, wenn die Batterie durch einen falschen Typ ersetzt wird. Ersetzen Sie die Batterie nur durch den gleichen oder vom Hersteller empfohlenen Batterietyp. Entsorgen Sie die benutzten Batterien nach den Anweisungen des Herstellers.

### ATTENTION

Il existe un risque d'explosion si la batterie est remplacée par un type incorrect. Ne la remplacer que par une pile de type semblable ou équivalent, recommandée par le fabricant. Jeter les piles usagées conformément aux instructions du fabricant.

### ADVERTENCIA

Existe riesgo de explosión si la batería se reemplaza por un tipo incorrecto. Reemplazar la batería exclusivamente con el mismo tipo o el equivalente recomendado por el fabricante. Desechar las baterías gastadas según las instrucciones del fabricante.

אזהרה!

קיימת סכנת פיצוץ אם הסוללה תוחלף בסוג שגוי. יש להחליף את הסוללה בסוג התואם מחברת יצרן מומלצת. סילוק הסוללות המשומשות יש לבצע לפי הוראות היצרן.

هناك خطر الانفجار إذا تم استبدال البطارية بنوع غير صحيح.  
 اسحبذال البطارية  
 فقط بنفس النوع أو ما يعادلها مما أوصت به الشركة المصنعة  
 جخلص من البطاريات المسحمة وفقا لعمليات الشركة الصانعة

경고!

배터리를 잘못된 종류로 교체하면 폭발의 위험이 있습니다. 기존 배터리와 동일하거나 제조사에서 권장하는 동등한 종류의 배터리로만 교체해야 합니다. 제조사의 안내에 따라 사용된 배터리를 처리하여 주십시오.

#### WAARSCHUWING

Er bestaat explosiegevaar als de batterij wordt vervangen door een verkeerd type. Vervang de batterij slechts met hetzelfde of een equivalent type die door de fabrikant aanbevolen wordt. Gebruikte batterijen dienen overeenkomstig fabrieksvoorschriften afgevoerd te worden.

### Redundant Power Supplies



**Warning!** This unit might have more than one power supply connection. All connections must be removed to de-energize the unit.

冗長電源装置

このユニットは複数の電源装置が接続されている場合があります。

ユニットの電源を切るためには、すべての接続を取り外さなければなりません。

警告

此部件连接的电源可能不止一个，必须将所有电源断开才能停止给该部件供电。

警告

此装置连接的电源可能不只一个，必须切断所有电源才能停止对该装置的供电。

Warnung

Dieses Gerät kann mehr als eine Stromzufuhr haben. Um sicherzustellen, dass der Einheit kein Strom zugeführt wird, müssen alle Verbindungen entfernt werden.

## ¡Advertencia!

Puede que esta unidad tenga más de una conexión para fuentes de alimentación. Para cortar por completo el suministro de energía, deben desconectarse todas las conexiones.

## Attention

Cette unité peut avoir plus d'une connexion d'alimentation. Pour supprimer toute tension et tout courant électrique de l'unité, toutes les connexions d'alimentation doivent être débranchées.

אם קיים יותר מספק אחד

אזהרה!

ליחידה יש יותר מחיבור אחד של ספק. יש להסיר את כל החיבורים על מנת לרוקן את היחידה.

قد يكون لهذا الجهاز عدة اتصالات بوحدات امداد الطاقة .

يجب إزالة كافة الاتصالات لعسل الوحدة عن الكهرباء

## 경고!

이 장치에는 한 개 이상의 전원 공급 단자가 연결되어 있을 수 있습니다. 이 장치에 전원을 차단하기 위해서는 모든 연결 단자를 제거해야만 합니다.

## Waarschuwing

Deze eenheid kan meer dan één stroomtoevoeraansluiting bevatten. Alle aansluitingen dienen verwijderd te worden om het apparaat stroomloos te maken.

## Backplane Voltage



**Warning!** Hazardous voltage or energy is present on the backplane when the system is operating. Use caution when servicing.

バックプレーンの電圧

システムの稼働中は危険な電圧または電力が、バックプレーン上にかかっています。

修理する際には注意ください。

警告

当系统正在进行时，背板上有很危险的电压或能量，进行维修时务必小心。

警告

當系統正在進行時，背板上有危險的電壓或能量，進行維修時務必小心。

Warnung

Wenn das System in Betrieb ist, treten auf der Rückwandplatine gefährliche Spannungen oder Energien auf. Vorsicht bei der Wartung.

¡Advertencia!

Cuando el sistema está en funcionamiento, el voltaje del plano trasero es peligroso. Tenga cuidado cuando lo revise.

Attention

Lorsque le système est en fonctionnement, des tensions électriques circulent sur le fond de panier. Prendre des précautions lors de la maintenance.

מתח בפנל האחורי

אזהרה!

קיימת סכנת מתח בפנל האחורי בזמן תפעול המערכת. יש להיזהר במהלך העבודה.

هناك خطر من التيار الكهربائي أو الطاقة المتجددة على اللوحة  
عندما يكون النظام يعمل كه حذرا عند خدمة هذا الجهاز

경고!

시스템이 동작 중일 때 후면판 (Backplane)에는 위험한 전압이나 에너지가 발생 합니다.  
서비스 작업 시 주의하십시오.

Waarschuwing

Een gevaarlijke spanning of energie is aanwezig op de backplane wanneer het systeem in gebruik is. Voorzichtigheid is geboden tijdens het onderhoud.

## Comply with Local and National Electrical Codes



**Warning!** Installation of the equipment must comply with local and national electrical codes.

地方および国の電気規格に準拠

機器の取り付けはその地方および国の電気規格に準拠する必要があります。

警告

设备安装必须符合本地与本国电气法规。

警告

設備安裝必須符合本地與本國電氣法規。

Warnung

Die Installation der Geräte muss den Sicherheitsstandards entsprechen.

¡Advertencia!

La instalación del equipo debe cumplir con las normas de electricidad locales y nacionales.

Attention

L'équipement doit être installé conformément aux normes électriques nationales et locales.

תיאום חוקי החשמל הארצי  
אזהרה!  
התקנת הציוד חייבת להיות תואמת לחוקי החשמל המקומיים והארציים.

تركيب المعدات الكهربائية يجب أن يمتثل للقوايه المحلية والبطية المتعلقة  
بالكهرباء

경고!

현 지역 및 국가의 전기 규정에 따라 장비를 설치해야 합니다.

Waarschuwing

Bij installatie van de apparatuur moet worden voldaan aan de lokale en nationale elektriciteitsvoorschriften.

## Product Disposal



**Warning!** Ultimate disposal of this product should be handled according to all national laws and regulations.

製品の廃棄

この製品を廃棄処分する場合、国の関係する全ての法律・条例に従い処理する必要があります。

警告

本产品的废弃处理应根据所有国家的法律和规章进行。

警告

本產品的廢棄處理應根據所有國家的法律和規章進行。

Warnung

Die Entsorgung dieses Produkts sollte gemäß allen Bestimmungen und Gesetzen des Landes erfolgen.

¡Advertencia!

Al deshacerse por completo de este producto debe seguir todas las leyes y reglamentos nacionales.

## Attention

La mise au rebut ou le recyclage de ce produit sont généralement soumis à des lois et/ou directives de respect de l'environnement. Renseignez-vous auprès de l'organisme compétent.

סילוק המוצר

אזהרה!

סילוק סופי של מוצר זה חייב להיות בהתאם להנחיות וחוקי המדינה.

التخلص النهائي من هذا المنتج ينبغي التعامل معه وفقا لجميع القوانين واللوائح الوطنية عند

경고!

이 제품은 해당 국가의 관련 법규 및 규정에 따라 폐기되어야 합니다.

## Waarschuwing

De uiteindelijke verwijdering van dit product dient te geschieden in overeenstemming met alle nationale wetten en reglementen.

## Fan Warning



**Warning!** Hazardous moving parts. Keep away from moving fan blades. The fans might still be turning when you remove the fan assembly from the chassis. Keep fingers, screwdrivers, and other objects away from the openings in the fan assembly's housing.

ファンの警告

警告!回転部品に注意。運転中は回転部(羽根)に触れないでください。シャーシから冷却ファン装置を取り外した際、ファンがまだ回転している可能性があります。ファンの開口部に、指、ドライバー、およびその他のものを近づけないで下さい。

警告!

警告! 危险的可移动性零件。请务必与转动的风扇叶片保持距离。当您从机架移除风扇装置，风扇可能仍在转动。小心不要将手指、螺丝起子和其他物品太靠近风扇

警告

危险的可移动性零件。请务必与转动的风扇叶片保持距离。当您从机架移除风扇装置，风扇可能仍在转动。小心不要将手指、螺丝起子和其他物品太靠近风扇。

**Warnung**

Gefährlich Bewegende Teile. Von den bewegenden Lüfterblätter fern halten. Die Lüfter drehen sich u. U. noch, wenn die Lüfterbaugruppe aus dem Chassis genommen wird. Halten Sie Finger, Schraubendreher und andere Gegenstände von den Öffnungen des Lüftergehäuses entfernt.

**¡Advertencia!**

Riesgo de piezas móviles. Mantener alejado de las aspas del ventilador. Los ventiladores podran dar vuelta cuando usted quite el montaje del ventilador del chasis. Mantenga los dedos, los destornilladores y todos los objetos lejos de las aberturas del ventilador

**Attention**

Pieces mobiles dangereuses. Se tenir a l'écart des lames du ventilateur Il est possible que les ventilateurs soient toujours en rotation lorsque vous retirerez le bloc ventilateur du châssis. Prenez garde à ce que doigts, tournevis et autres objets soient éloignés du logement du bloc ventilateur.

**אזהרה!**

חלקים נעים מסוכנים. התרחק מלהבי המאוורר בפעולה כאשר מסירים את חלקי המאוורר מהמארז, יתכן והמאווררים עדיין עובדים. יש להרחיק למרחק בטוח את האצבעות וכלי עבודה שונים מהפתחים בתוך המאוורר

تحذير! أجزاء متحركة خطيرة. ابتعد عن شفرات المروحة المتحركة. من الممكن أن المراوح لا تزال تدور عند إزالة كتلة المروحة من الهيكل يجب إبقاء الأصابع ومفكات البراغي وغيرها من الأشياء بعيدا عن الفتحات في كتلة المروحة

**경고!**

움직이는 위험한 부품. 회전하는 송풍 날개에 접근하지 마세요. 새시로부터 팬 조립품을 제거할 때 팬은 여전히 회전하고 있을 수 있습니다. 팬 조립품 외관의 열려있는 부분들로부터 손가락 및 스크류드라이버, 다른 물체들이 가까이 하지 않도록 배치해 주십시오.

**Waarschuwing**

Gevaarlijk bewegende onderdelen. Houd voldoende afstand tot de bewegende ventilatorbladen. Het is mogelijk dat de ventilator nog draait tijdens het verwijderen van het ventilatorsamenstel uit het chassis. Houd uw vingers, schroevendraaiers en eventuele andere voorwerpen uit de buurt van de openingen in de ventilatorbehuizing.

## Power Cable and AC Adapter



**Warning!** When installing the product, use the provided or designated connection cables, power cables and AC adaptors. Using any other cables and adaptors could cause a malfunction or a fire. Electrical Appliance and Material Safety Law prohibits the use of UL or CSA -certified cables (that have UL/CSA shown on the cord) for any other electrical devices than products designated by Supermicro only.

### 電源コードとACアダプター

製品を設置する場合、提供または指定および購入された接続ケーブル、電源コードとACアダプターを該当する地域の条例や安全基準に適合するコードサイズやプラグと共に使用下さい。他のケーブルやアダプタを使用すると故障や火災の原因になることがあります。

電気用品安全法は、ULまたはCSA認定のケーブル(UL/CSAマークがコードに表記)を Supermicro が指定する製品以外に使用することを禁止しています。

### 警告

安装此产品时,请使用本身提供的或指定的或采购的连接线,电源线和电源适配器。包含遵照当地法规和安全要求的合规的电源线尺寸和插头。使用其它线材或适配器可能会引起故障或火灾。除了Supermicro所指定的产品,电气用品和材料安全法律规定禁止使用未经UL或CSA认证的线材。(线材上会显示UL/CSA符号)。

### 警告

安裝此產品時,請使用本身提供的或指定的或採購的連接線,電源線和電源適配器。包含遵照當地法規和安全要求的合規的電源線尺寸和插頭。使用其它線材或適配器可能會引起故障或火災。除了Supermicro所指定的產品,電氣用品和材料安全法律規定禁止使用未經UL或CSA認證的線材。(線材上會顯示UL/CSA符號)。

### Warnung

Nutzen Sie beim Installieren des Produkts ausschließlich die von uns zur Verfügung gestellten Verbindungskabeln, Stromkabeln und/oder Adapter, die Ihre örtlichen Sicherheitsstandards einhalten. Der Gebrauch von anderen Kabeln und Adapter können Fehlfunktionen oder Feuer verursachen. Die Richtlinien untersagen das Nutzen von UL oder CAS zertifizierten Kabeln (mit UL/CSA gekennzeichnet), an Geräten oder Produkten die nicht mit Supermicro gekennzeichnet sind.

## ¡Advertencia!

Cuando instale el producto, utilice la conexión provista o designada o procure cables, Cables de alimentación y adaptadores de CA que cumplan con los códigos locales y los requisitos de seguridad, incluyendo el tamaño adecuado del cable y el enchufe. El uso de otros cables y adaptadores podría causar un mal funcionamiento o un incendio. La Ley de Seguridad de Aparatos Eléctricos y de Materiales prohíbe El uso de cables certificados por UL o CSA (que tienen el certificado UL / CSA en el código) para cualquier otros dispositivos eléctricos que los productos designados únicamente por Supermicro.

## Attention

Lors de l'installation du produit, utilisez les cables de connection fournis ou désigné ou achetez des cables, cables de puissance et adaptateurs respectant les normes locales et les conditions de securite y compris les tailles de cables et les prises electriques appropries. L'utilisation d'autres cables et adaptateurs peut provoquer un dysfonctionnement ou un incendie. Appareils électroménagers et la Loi sur la Sécurité Matériel interdit l'utilisation de câbles certifiés- UL ou CSA (qui ont UL ou CSA indiqué sur le code) pour tous les autres appareils électriques sauf les produits désignés par Supermicro seulement.

AC ימאתמו מיי למשח מילבכ

!הרהזא

ךרוצל ומאתוה וא ושכרנ רשא AC מיימאתמו מיקפס, מילבכב שמתשהל שי, רצומה תא מיניקתמ רשאכ לכב שומיש . עקתהו לבכה לש הנוכח הדימ ללוכ, תוימוקמה תוחיטבה תושירדל ומאתוה רשאו, הנקתהה למשחה ירישכמב שומישה יקוחל מאתהב. ילמשח רצק וא הלקתל מורגל לולע, רחא גוסמ מאתמ וא לבכ לש דוק מהילע עיפומ רשאכ) UL-ב או CSA-ב (ב-מיימאתמו מילבכב שמתשהל רוסיא מייק, תוחיטבה יקוחו דבלב Supermicro י"ע מאתוה רשא רצומב קר אלא, רחא ילמשח רצומ לכ רובע UL/CSA)

תאלבאלא אארשב מץ וא אדדחמלא וא ארפוטמלא תאליטוטלא מאדחטסאב מץ, אגתנמלא בייקרת דנע לכלז ייפ אב עילחמלא עמאלסלא תאבלטתמו נינאווקב מאזתלאל עמ דדרתמלא ראיטלא תאלוחמו עיילברמלא קיירח וא לטע ייפ בבסטטי דץ ירשא תאלוחמו תאלבאלא יא מאדחטסא. מייסלא סבאלאו לטוומלא מץ ח. CSA וא UL לביק נמ אדמעתמלא תאלבאלא מאדחטסא תאדעמלא עיילברמלא אזהאלל עמאלסלא נונאק רזחיי Supermicro לביק נמ אדדחמלא עיילברמלא תאגתנמלא רייג ירשא תאדעמ יא עמ (UL/CSA) עמאלע למחתי יתלאו

### 전원 케이블 및 AC 어댑터

경고! 제품을 설치할 때 현지 코드 및 적절한 굵기의 코드와 플러그를 포함한 안전 요구 사항을 준수하여 제공되거나 지정된 연결 혹은 구매 케이블, 전원 케이블 및 AC 어댑터를 사용하십시오.

다른 케이블이나 어댑터를 사용하면 오작동이나 화재가 발생할 수 있습니다. 전기 용품 안전법은 UL 또는 CSA 인증 케이블 (코드에 UL / CSA가 표시된 케이블)을 Supermicro 가 지정한 제품 이외의 전기 장치에 사용하는 것을 금지합니다.

### Stroomkabel en AC-Adapter

Waarschuwing! Bij het aansluiten van het Product uitsluitend gebruik maken van de geleverde Kabels of een andere geschikte aan te schaffen Aansluitmethode, deze moet altijd voldoen aan de lokale voorschriften en veiligheidsnormen, inclusief de juiste kabeldikte en stekker. Het gebruik van niet geschikte Kabels en/of Adapters kan een storing of brand veroorzaken. Wetgeving voor Elektrische apparatuur en Materiaalveiligheid verbied het gebruik van UL of CSA -gecertificeerde Kabels (met UL/CSA in de code) voor elke andere toepassing dan de door Supermicro hiervoor beoogde Producten.

# Appendix B

## System Specifications

### Processor Support

Single AMD EPYC™ 9004/9005 series processors in SP5 socket and a Thermal Design Power unit up to 400 W (\*AMD EPYC™ 9005 series drop-in support requires board revision 2.x)

The power of the TDP unit depends on thermal validation and system configuration. Contact a Supermicro representative for details.

### Chipset

System on Chip (SoC)

### BIOS

ACPI 6.4, SMBIOS 3.5, Plug-and-Play (PnP), RTC (Real Time Clock) wakeup, Riser Card Auto-Detection Support

### Memory (per node)

12 DIMM Slots

Max Memory (1DPC): Up to 3 TB 4800 MT/s ECC DDR5 RDIMM (AMD EPYC™ 9004 Series Processor, MB R1.x/R2.0/R2.01)

Max Memory (1DPC): Up to 3 TB 6000 MT/s ECC DDR5 RDIMM (AMD EPYC™ 9005 Series Processor, MB R2.0)

Max Memory (1DPC): Up to 3 TB 6400 MT/s ECC DDR5 RDIMM (AMD EPYC™ 9005 Series Processor, MB R2.01)

(Motherboard revision 2.0 or above is required)\*

\*For details, please refer to [Section 3.5](#).

### Storage Drives (per node)

Front hot-swappable drives:

Supports up to four SATA/SAS/NVMe drives depending on selected enablement kits

M.2 drives:

Two M.2 in 2280 (PCIe 5.0 x4 & SATA)

### One Motherboard (per node)

H13SST-G; 11.2" (L) x 8.52" (W), (284.48 x 216.4 mm)

### Chassis

CSE-GT214BF-R2K21BP2; 2U rackmount, 17.67 x 3.46 x 28 in. (449 x 87.9 x 711.2 mm)

### System Cooling

Two 80-mm mid chassis fans per system, one fan integrated inside the power supply;

one CPU heatsink per node, one CPU air shroud per node

### Dummy Tray

MCP-120-21405-0N

To avoid overheating, please ensure a dummy tray is inserted into any unused drive bays.

**Power Supply**

Model: two 2200 W Redundant (1 + 1) Titanium Level (96%) power supplies  
(Power supply full redundancy based on configuration and application load)

AC Input Voltages: 100-240 VAC

Rated Input Current:

1200 W: 100-127 Vac

1800 W: 200-220 Vac

1980 W: 220-230 Vac

2090 W: 230-240 Vac (TUV/CB)

2200 W: 220-240 Vac (WL/cUL only)

2090 W: 180-220 Vac (UL/cUL only)

2090 W: 230-240 Vdc (CCC only)

Rated Input Frequency: 50-60 Hz

Rated Output Power: +12 V

Max: 100 A / Min: 0 A (100-127 Vac)

Max: 150 A / Min: 0 A (200-220 Vac)

Max: 165 A / Min: 0 A (220-230 Vac)

Max: 174.17 A / Min: 0A (230-240 Vac)

Max: 174.17 A / Min: 0A (180-220 Vac, UL/cUL only)

Max: 183.33 A / Min: 0A (220-240 Vac, UL/cUL only)

Max: 174.17 A / Min: 0A (230-240 Vdc, CCC only)

Standby +12 Vsb: Max: 2.1 A / Min: 0 A

**Operating Environment**

Operating Temperature: 10°C to 35°C (50°F to 95°F)

Non-operating Temperature: -30°C to 60°C (-22°F to 140°F)

Operating Relative Humidity: 8% to 80% (non-condensing)

Non-operating Relative Humidity: 8% to 90% (non-condensing)

**Regulatory Compliance**

FCC, ICES, CE, VCCI, RCM, NRTL, CB, UKCA, KCC, BSMI

**Applied Directives, Standards**

Electromagnetic Compatibility Regulations 2016

FCC Part 15

ICES-003

VCCI-CISPR 32

AS/NZS CISPR 32

BS/EN 55032

BS/EN 55035

CISPR 32

CISPR 35

BS/EN 61000-3-2

BS/EN 61000-3-3

BS/EN 61000-4-2

BS/EN 61000-4-3

BS/EN 61000-4-4

BS/EN 61000-4-5

BS/EN 61000-4-6

BS/EN 61000-4-8

BS/EN 61000-4-11

Product Safety: 2014/35/EU (LVD Directive)

UL/CSA 62368-1 (USA and Canada)

Electrical Equipment (Safety) Regulations 2016

IEC/BS/EN 62368-1

Environment:

2011/65/EU (RoHS Directive)

EC 1907/2006 (REACH)

2012/19/EU (WEEE Directive)

Warning! This product can expose you to chemicals including lead, known to the State of California to cause cancer and birth defects or other reproductive harm. For more information, go to [www.P65Warnings.ca.gov](http://www.P65Warnings.ca.gov).

**Perchlorate Warning**

California Best Management Practices Regulations for Perchlorate Materials: This Perchlorate warning applies only to products containing CR (Manganese Dioxide) Lithium coin cells. Perchlorate Material-special handling may apply. See [www.dtsc.ca.gov/hazardouswaste/perchlorate](http://www.dtsc.ca.gov/hazardouswaste/perchlorate).

この装置は、クラスA機器です。この装置を住宅環境で使用すると電波妨害を引き起こすことがあります。この場合には使用者が適切な対策を講ずるよう要求されることがあります。

VCCI - A

## BSMI Compliance

## 限用物質含有情況標示聲明書

Declaration of the Presence Condition of the Restricted Substances Marking

設備名稱：伺服器 / Server Equipment name						
型號（型式）： GT214BF-R22H13 Type designation (Type)						
(系列型號： GT214BF -4N, AS -2115GT-HNTF )						
單元 Unit	限用物質及其化學符號 Restricted substances and its chemical symbols					
	鉛Lead (Pb)	汞Mercury (Hg)	鎘Cadmium (Cd)	六價鉻 Hexavalent chromium (Cr <sup>+6</sup> )	多溴聯苯 Polybrominated biphenyls (PBB)	多溴二苯醚 Polybrominated diphenyl ethers (PBDE)
機殼 (Chassis)	○	○	○	○	○	○
機殼風扇 (Chassis Fan)	—	○	○	○	○	○
線材 (Cable)	○	○	○	○	○	○
主機板 (Motherboard)	—	○	○	○	○	○
電源供應器 (Power Supply)	—	○	○	○	○	○
電源背板 (PDB)	—	○	○	○	○	○
硬碟 (SSD)	—	○	○	○	○	○
附加卡 (Add-on card)	—	○	○	○	○	○
備考1. “超出0.1 wt %” 及 “超出0.01 wt %” 係指限用物質之百分比含量超出百分比含量基準值。 Note 1 : “Exceeding 0.1 wt %” and “exceeding 0.01 wt %” indicate that the percentage content of the restricted substance exceeds the reference percentage value of presence condition.						
備考2. “○” 係指該項限用物質之百分比含量未超出百分比含量基準值。 Note 2 : “○” indicates that the percentage content of the restricted substance does not exceed the percentage of reference value of presence.						
備考3. “—” 係指該項限用物質為排除項目。 Note 3 : The “—” indicates that the restricted substance corresponds to the exemption.						

警告：為避免電磁干擾，本產品不應安裝或使用於住宅環境。

輸入額定：

100-127V ~, 60-50Hz, 12-11A (x2)

200-240V ~, 60-50Hz, 10-9.8A (x2)

\*使用者不能任意拆除或替換內部配備

\*報驗義務人之姓名或名稱：美超微電腦股份有限公司

\*報驗義務人之地址：新北市中和區建一路 150 號 3 樓