



FATTWIN SERVER[®]

SYS-F521E3-RTB



USER'S MANUAL

Revision 1.0a

The information in this User's Manual has been carefully reviewed and is believed to be accurate. The vendor assumes no responsibility for any inaccuracies that may be contained in this document, and makes no commitment to update or to keep current the information in this manual, or to notify any person or organization of the updates. Please Note: For the most up-to-date version of this manual, please see our website at www.supermicro.com.

Super Micro Computer, Inc. ("Supermicro") reserves the right to make changes to the product described in this manual at any time and without notice. This product, including software and documentation, is the property of Supermicro and/or its licensors, and is supplied only under a license. Any use or reproduction of this product is not allowed, except as expressly permitted by the terms of said license.

IN NO EVENT WILL Super Micro Computer, Inc. BE LIABLE FOR DIRECT, INDIRECT, SPECIAL, INCIDENTAL, SPECULATIVE OR CONSEQUENTIAL DAMAGES ARISING FROM THE USE OR INABILITY TO USE THIS PRODUCT OR DOCUMENTATION, EVEN IF ADVISED OF THE POSSIBILITY OF SUCH DAMAGES. IN PARTICULAR, SUPER MICRO COMPUTER, INC. SHALL NOT HAVE LIABILITY FOR ANY HARDWARE, SOFTWARE, OR DATA STORED OR USED WITH THE PRODUCT, INCLUDING THE COSTS OF REPAIRING, REPLACING, INTEGRATING, INSTALLING OR RECOVERING SUCH HARDWARE, SOFTWARE, OR DATA.

Any disputes arising between manufacturer and customer shall be governed by the laws of Santa Clara County in the State of California, USA. The State of California, County of Santa Clara shall be the exclusive venue for the resolution of any such disputes. Supermicro's total liability for all claims will not exceed the price paid for the hardware product.

FCC Statement: This equipment has been tested and found to comply with the limits for a Class A or Class B digital device pursuant to Part 15 of the FCC Rules. These limits are designed to provide reasonable protection against harmful interference when the equipment is operated in industrial environment for Class A device or in residential environment for Class B device. This equipment generates, uses, and can radiate radio frequency energy and, if not installed and used in accordance with the manufacturer's instruction manual, may cause harmful interference with radio communications. Operation of this equipment in a residential area is likely to cause harmful interference, in which case you will be required to correct the interference at your own expense.

California Best Management Practices Regulations for Perchlorate Materials: This Perchlorate warning applies only to products containing CR (Manganese Dioxide) Lithium coin cells. "Perchlorate Material-special handling may apply. See www.dtsc.ca.gov/hazardouswaste/perchlorate".



WARNING: This product can expose you to chemicals including lead, known to the State of California to cause cancer and birth defects or other reproductive harm. For more information, go to www.P65Warnings.ca.gov.

The products sold by Supermicro are not intended for and will not be used in life support systems, medical equipment, nuclear facilities or systems, aircraft, aircraft devices, aircraft/emergency communication devices or other critical systems whose failure to perform be reasonably expected to result in significant injury or loss of life or catastrophic property damage. Accordingly, Supermicro disclaims any and all liability, and should buyer use or sell such products for use in such ultra-hazardous applications, it does so entirely at its own risk. Furthermore, buyer agrees to fully indemnify, defend and hold Supermicro harmless for and against any and all claims, demands, actions, litigation, and proceedings of any kind arising out of or related to such ultra-hazardous use or sale.

Manual Revision 1.0a

Release Date: March 21, 2023

mk

Unless you request and receive written permission from Super Micro Computer, Inc., you may not copy any part of this document. Information in this document is subject to change without notice. Other products and companies referred to herein are trademarks or registered trademarks of their respective companies or mark holders.

Copyright © 2023 by Super Micro Computer, Inc.
All rights reserved.

Printed in the United States of America

Preface

About this Manual

This manual is written for professional system integrators and PC technicians. It provides information for the installation and use of the server. Installation and maintenance should be performed by experienced technicians only.

Please refer to the SYS-F521E3-RTB [server specifications page](#) on our website for updates on supported memory, processors and operating systems.

Notes

For your system to work properly, please follow the links below to download all necessary drivers/utilities and the user's manual for your server.

- Supermicro product manuals: <https://www.supermicro.com/support/manuals/>
- Product drivers and utilities: <https://www.supermicro.com/wdl>
- Product safety info: https://www.supermicro.com/about/policies/safety_information.cfm

If you have any questions, please contact our support team at:
support@supermicro.com

This manual may be periodically updated without notice. Please check the Supermicro website for possible updates to the manual revision level.

Secure Data Deletion

A secure data deletion tool designed to fully erase all data from storage devices can be found on our website: https://www.supermicro.com/about/policies/disclaimer.cfm?url=/wdl/utility/Lot9_Secure_Data_Deletion_Utility/

Warnings

Special attention should be given to the following symbols used in this manual.



Warning! Indicates important information given to prevent equipment/property damage or personal injury.



Warning! Indicates high voltage may be encountered when performing a procedure.

Contents

Chapter 1 Introduction

1.1 Overview.....	9
System Nodes.....	10
1.2 System Features.....	11
System: Front View.....	11
Control Panel.....	12
Node: Front View.....	13
Drive Carrier Indicators.....	13
System: Rear View.....	14
Node: Rear View.....	16
LAN Speed Indicator.....	16
1.3 System Architecture.....	17
Node: Main Components.....	17
1.4 Motherboard Layout.....	18
Quick Reference.....	19
Motherboard Block Diagram.....	20

Chapter 2 Server Installation

2.1 Overview.....	21
2.2 Unpacking the System.....	21
2.3 Preparing for Setup.....	21
Choosing a Setup Location.....	21
Rack Precautions.....	22
Server Precautions.....	22
Rack Mounting Considerations.....	22
2.4 Procedure for Rack Mounting.....	24
Overview of the Rack Rails.....	24
Adjusting the Rails.....	24
Installing the Rails on a Rack.....	25
Chassis Installation.....	26
Removing the Chassis from the Rack.....	27

Chapter 3 Maintenance and Component Installation

3.1 Removing Power.....	28
-------------------------	----

3.2	Accessing the Nodes	29
	Removing Nodes from the Chassis	29
	Removing the Cover from the Node	30
3.3	Processor and Heatsink	31
	Processor Overview	31
	Installation Overview	32
	Installation Procedure Overview	32
	Create the Processor Carrier Assembly	33
	Assemble the Processor Heatsink Module	37
	Remove the Socket Cover	39
	Install the PHM	40
	Removing the Processor	43
	Removing the PHM	43
	Removing the Carrier Assembly from the Heatsink	44
	Removing the Processor from the Carrier Assembly	45
3.4	Memory	46
	Memory Support	46
	Memory Population Guidelines	48
	Guidelines Regarding Mixing DIMMs	48
	DIMM Construction	48
	Memory Population Sequence	48
	Installing Memory	49
3.5	Motherboard Battery	50
3.6	Storage Drives	51
	Drive Layout Configurations	51
	0 NVMe / 8 SAS/SATA drives	51
	2 NVMe / 6 SAS/SATA drives	52
	4 NVMe / 4 SAS/SATA drives	52
	6 NVMe / 2 SAS/SATA drives	52
	8 NVMe / 0 SAS/SATA drives	52
	Installing and Removing Hard Drives	52
	Installing and Removing the Storage Drives	53
	Hot-Swap for NVMe Drives	55
	Checking the Temperature of an NVMe Drive	56
	Installing M.2 Solid State Drives	57

3.7 System Cooling	58
Fans	58
Air Shrouds	59
3.8 Expansion Cards	60
3.9 Installing an AIOM Module	61
3.10 Power Supply	62
Power Supply LEDs	62
Power Supply Results	64
3.11 Cable Routing Diagram	66
Chapter 4 Motherboard Connections	
4.1 Input/Output Ports	67
4.2 Power Connections	69
4.3 Headers and Connectors	70
4.4 Jumpers	72
4.5 LED Indicators	73
Chapter 5 Software	
5.1 Microsoft Windows OS Installation	74
5.2 Driver Installation	76
5.3 SuperDoctor® 5	77
5.4 BMC	78
BMC ADMIN User Password	78
Chapter 6 Optional Components	
6.1 Storage Protocols Supported	79
6.2 TPM Security Module	79
6.3 Intel Virtual RAID on CPU (VROC)	80
Requirements and Restrictions	80
Supported SSDs and Operating Systems	80
Additional Information	81
Hardware Key	81
Configuring Intel VMD	82
Configuring VMD Manually	82
Creating NVMe RAID Configurations	86
Status Indications	87

Hot-Swap Drives	87
Hot-unplug	87
Hot-plug	87
Related Information Links	87
Chapter 7 Troubleshooting and Support	
7.1 Information Resources	88
Website	88
Direct Links for the SYS-F521E3-RTB System.....	88
Direct Links for General Support and Information	88
7.2 BMC Interface	89
7.3 Troubleshooting Procedures	90
General Technique	90
No Power	90
No Video	91
System Boot Failure	91
Memory Errors	91
Losing the System Setup Configuration	91
When the System Becomes Unstable	91
7.4 POST Codes	93
7.5 Crash Dump Using the BMC Dashboard.....	93
7.6 UEFI BIOS Recovery	94
Overview	94
Recovering the UEFI BIOS Image.....	94
Recovering the Main BIOS Block with a USB Device	94
7.7 CMOS Clear	99
7.8 BMC Reset.....	99
7.9 Where to Get Replacement Components	100
7.10 Reporting an Issue.....	100
Technical Support Procedures	100
Returning Merchandise for Service.....	100
Vendor Support Filing System	101
7.11 Feedback.....	101
7.12 Contacting Supermicro.....	102
Appendix A Standardized Warning Statements for AC Systems	
Appendix B System Specifications	

Contacting Supermicro

Headquarters

Address: Super Micro Computer, Inc.
980 Rock Ave.
San Jose, CA 95131 U.S.A.

Tel: +1 (408) 503-8000

Fax: +1 (408) 503-8008

Email: marketing@supermicro.com (General Information)
Sales-USA@supermicro.com (Sales Inquiries)
Government_Sales-USA@supermicro.com (Gov. Sales Inquiries)
support@supermicro.com (Technical Support)
RMA@supermicro.com (RMA Support)
Webmaster@supermicro.com (Webmaster)

Website: www.supermicro.com

Europe

Address: Super Micro Computer B.V.
Het Sterrenbeeld 28, 5215 ML
's-Hertogenbosch, The Netherlands

Tel: +31 (0) 73-6400390

Fax: +31 (0) 73-6416525

Email: Sales_Europe@supermicro.com (Sales Inquiries)
Support_Europe@supermicro.com (Technical Support)
RMA_Europe@supermicro.com (RMA Support)

Website: www.supermicro.nl

Asia-Pacific

Address: Super Micro Computer, Inc.
3F, No. 150, Jian 1st Rd.
Zhonghe Dist., New Taipei City 235
Taiwan (R.O.C)

Tel: +886-(2) 8226-3990

Fax: +886-(2) 8226-3992

Email: Sales-Asia@supermicro.com.tw (Sales Inquiries)
Support@supermicro.com.tw (Technical Support)
RMA@supermicro.com.tw (RMA Support)

Website: www.supermicro.com.tw

Chapter 1

Introduction

1.1 Overview

This chapter provides a brief outline of the functions and features of the SuperServer SYS-F521E3-RTB. The following provides an overview of the specifications and capabilities.

System Overview	
Motherboard	<i>(per node)</i> One X13SEFR-A
Chassis	CSE-F424AS4-R2K08BP
Processor Support	<i>(per node)</i> One 4th Generation Intel Xeon Scalable processor in E (LGA-4677) sockets
Memory	<i>(per node)</i> Up to 4TB of ECC RDIMM/RDIMM 3DS DDR5 memory with speeds of up to 4800MT/s (DDR5-4400MT/s when fully populated) in 16 memory slots
Drive Support	<i>(per node)</i> Six front 3.5" hot-swap NVMe/SATA/SAS drive bays Two rear 3.5" hot-swap NVMe/SATA/SAS drive bays Two M.2 in 2280, 22110 (PCIe 3.0 x2 or SATA x1)
Expansion Slots	<i>(per node)</i> One PCIe 5.0 x16 LP external slot One PCIe 5.0 x16 AIOM (OCP 3.0)
I/O Ports	<i>(per node)</i> LAN ports depend on the AIOM card, PCIe 5.0 x16 (OCP 3.0) One dedicated BMC LAN port One VGA port (rear) Two USB 3.1 ports
System Cooling	<i>(per node)</i> Two heavy duty 8-cm fans with Optimal Fan Speed Control Air Shrouds
Power	Four Redundant Power Supplies, 80Plus Titanium level
Form Factor	4U; (WxHxD) 17.7" x 7.0" x 30.0" (448.5x177x762.5 mm)

A link to the Quick Reference Guide can be found on the [product page](#) of the Supermicro website.

The following safety models associated with the SYS-F521E3-RTB have been certified as compliant with UL and CSA: F424R-Q20X13, F424-FT, F424-20

System Nodes

The system includes four computing nodes. Each node is a separate system containing a drawer with a motherboard, fans, and other components, and may be removed from the chassis separately. Each node in the system supports separate storage drives.



Figure 1-1. System Showing Nodes

1.2 System Features

The following views of the system display the main features. Refer to [Appendix B](#) for additional specifications.

System: Front View

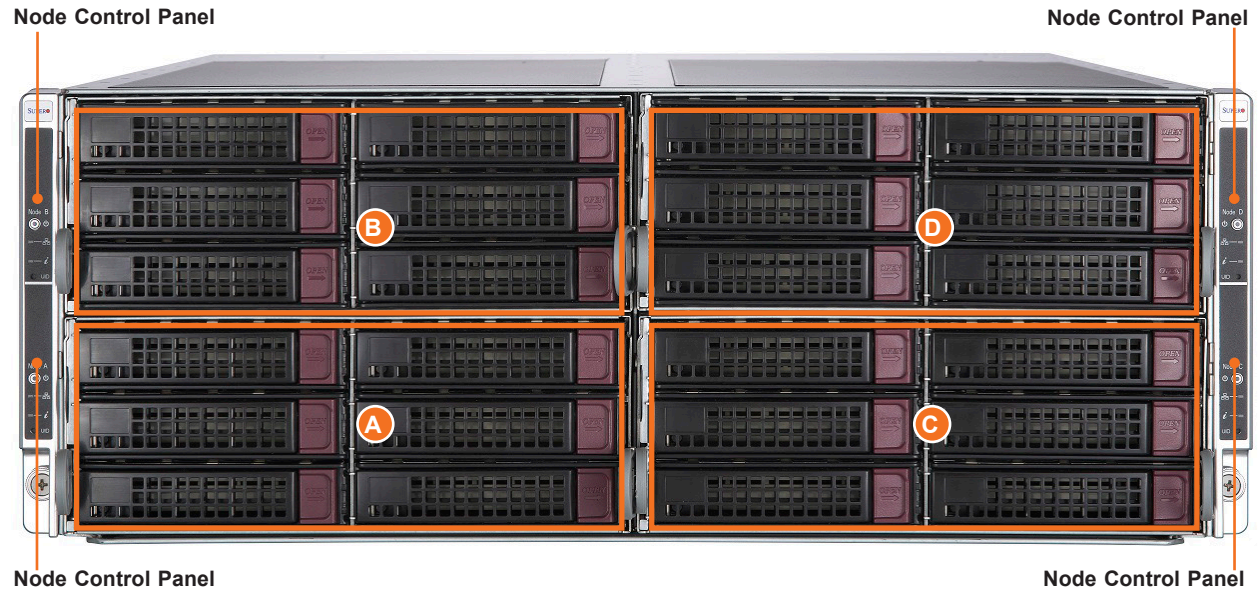

Figure 1-2. System: Front View

Logical Node and Drive Designations			
Node	Associated Drives	Node	Associated Drives
B	B0 through B5	D	D0 through D5
A	A0 through A5	C	C0 through C5

Control Panel

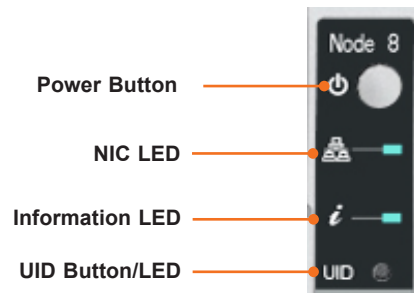

Figure 1-3. Control Panel

Control Panel Features	
Feature	Description
Power Button	Steady on – Power on Blinking at 4Hz – Checking BIOS/BMC integrity Blinking at 4Hz and "i" LED is blue – BIOS firmware updating Two blinks at 4Hz, one pause 2hz and "i" LED blue – BMC firmware updating Blinking at 1Hz and "i" LED red – Fault detected
NIC	Indicates network activity on LANs when flashing
Information LED	Alerts operator to several states, as noted in the table below
UID Button, LED/ BMC Reset	The unit identification (UID) button turns on or off the blue light function of the Information LED and a blue LED on the rear of the chassis. This button can also be used to reset the BMC .

Information LED	
Color, Status	Description
Red, solid	An overheat condition has occurred.
Red, blinking at 1Hz	Fan failure, check for an inoperative fan.
Red, blinking at 0.25Hz	Power failure, check for a non-operational power supply.
Red, solid, with Power LED blinking green	Fault detected
Blue and red, blinking at 10 Hz	Recovery mode
Blue, solid	UID has been activated locally to locate the server in a rack environment.
Blue, blinking at 1Hz	UID has been activated using the BMC to locate the server in a rack environment.
Blue, blinking at 2Hz	BMC is resetting
Blue, blinking at 4Hz	BMC is setting factory defaults
Blue, blinking at 10Hz with Power LED blinking green	BMC/BIOS firmware is updating

Node: Front View

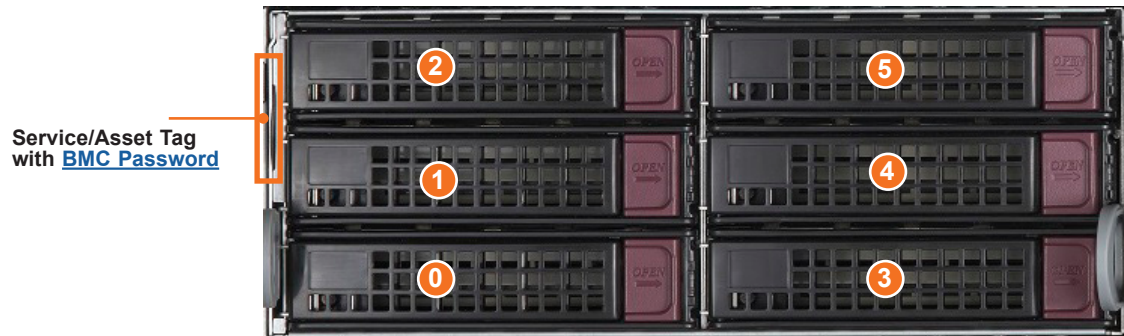

Figure 1-4. Node: Front View

Logical Storage Drive Numbers	
Item	Description
0-5	Logical Drive Number

Note: See Chapter 3 for SAS/SATA/NVMe drive configurations.

Drive Carrier Indicators

Each drive carrier has two LED indicators: an activity indicator and a status indicator. For RAID configurations using a controller, the meaning of the status indicator is described in the table below. For OS RAID or non-RAID configurations, some LED indications are not supported, such as hot spare.

Drive Carrier LED Indicators			
	Color	Blinking Pattern	Behavior for Device
Activity LED	Blue	Solid On	Idle SAS or NVMe drive installed
	Blue	Blinking	I/O activity
	Off		Idle SATA or no drive
Status LED	Red	Solid On	Failure of drive with RSTe support
	Red	Blinking at 1 Hz	Rebuild drive with RSTe support
	Red	Blinking at 4 Hz	Identify drive with RSTe support
	Red	Blinking with two blinks and one stop at 1 Hz	Hot spare for drive with RSTe support
	Red	On for five seconds, then off	Power on for drive with RSTe support
	Amber	Blinking	Do not remove NVMe drive
	Green	Solid on	Safe to remove NVMe drive

System: Rear View

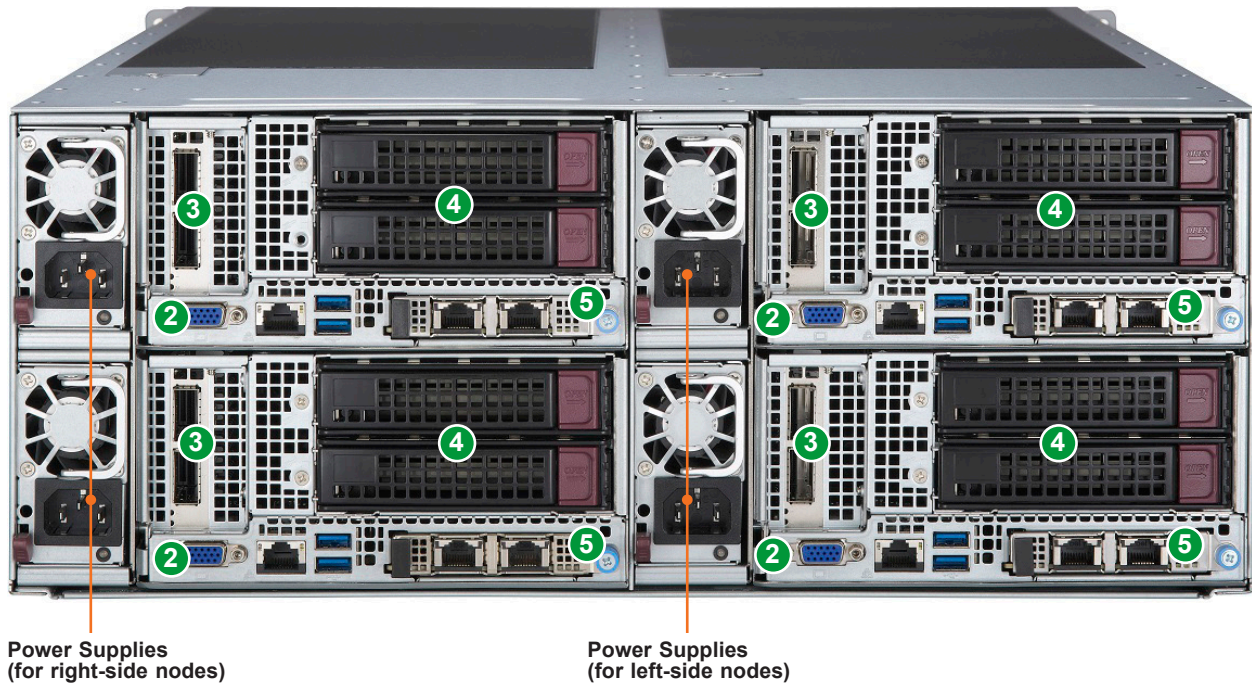

Figure 1-5. System: Rear View

System Features: Rear		
Item	Feature	Description
Power Supplies*		Four redundant power supplies, 1+1 power redundancy
2	Rear I/O Ports	Each node has its own rear I/O ports. See Chapter 3 for I/O port descriptions.
3	Expansion Card Slots	Each node has one PCIe 5.0 x16 expansion card slot
4	Storage Bays	Each node supports two 3.5" drives
5	AIOM Module Slots	Each node has one AIOM slot for additional network ports
UID LED (not shown)		Each node has one UID LED for each node location.

*Power supplies are independent and electrically isolated from the opposite-side nodes.

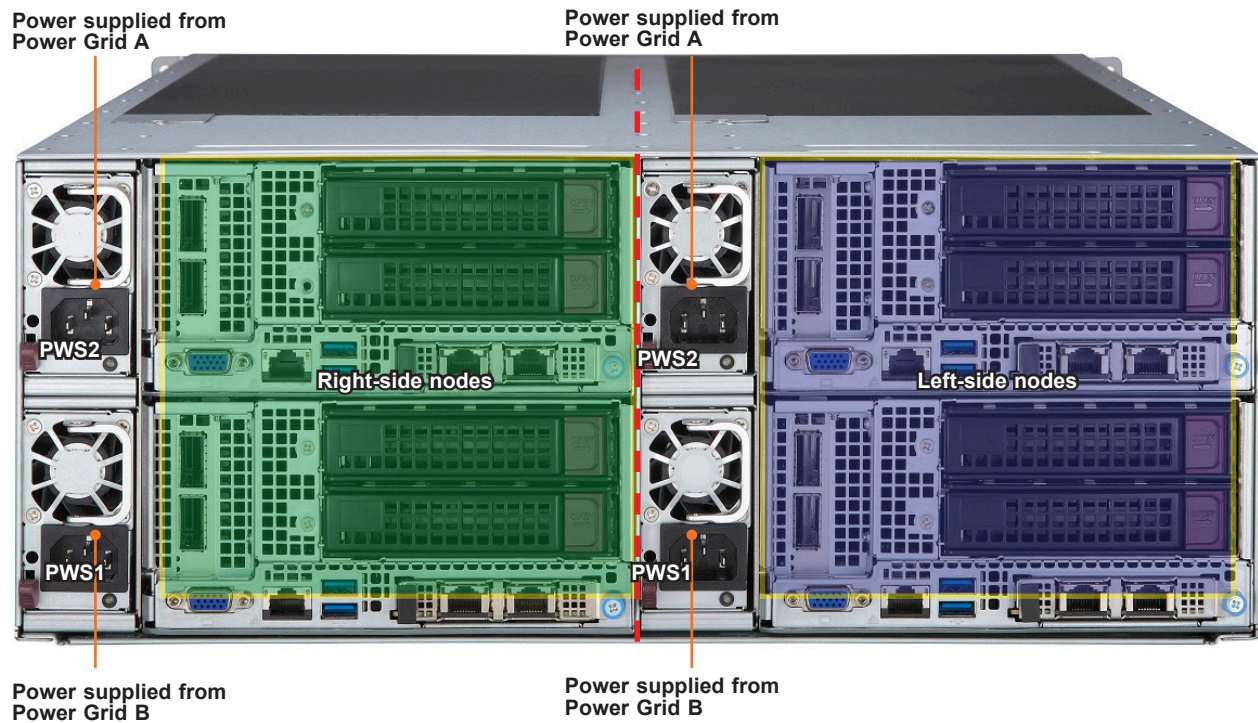

Figure 1-6. System Power Configuration

Power Supply Indicators		
Power Supply Condition	Green LED	Amber LED
No AC power to power supply	OFF	OFF
Power supply critical events causing a shutdown/ failure/ OCP/ OVP/ Fan Fail/ OTP/ UVP	OFF	Amber LED
Power supply warning events where the power supply continues to operate; high temperature; over voltage; under voltage, etc.	OFF	1Hz Blinking Amber
AC present only 12vsb on (PS off)	1Hz Blinking Green	OFF
Output ON and OK	Green	OFF
AC cord unplugged and in redundant mode	OFF	Amber

Node: Rear View

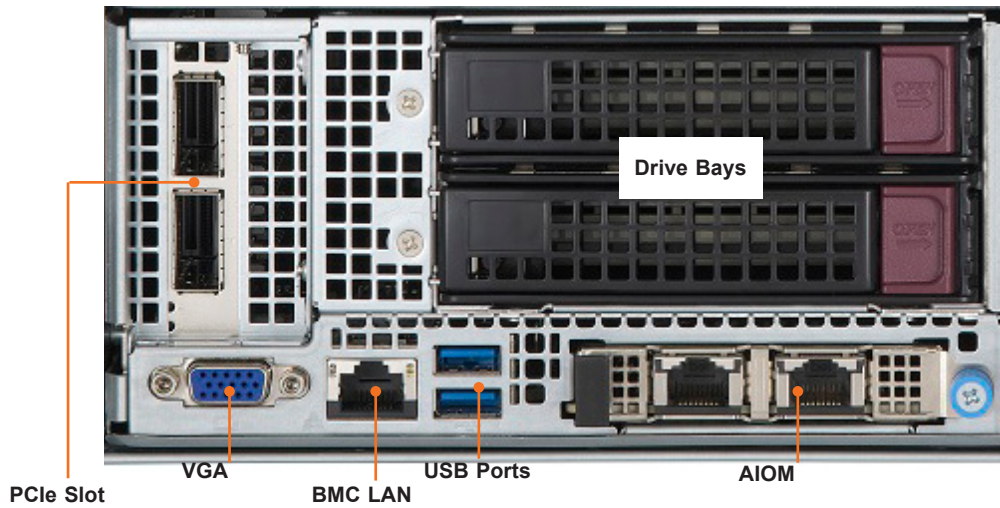

Figure 1-7. Node Features: Rear

Node Features: Rear	
Feature	Description
Drive Bays	Two 3.5" storage drives; can be converted to 2.5"
VGA	Video port
BMC LAN	Dedicated BMC LAN port; for indicator details, see BMC LAN LEDs
USB Ports	Two USB 3.0 ports
AIOM Slot	Advanced Input/Output module for network connections

LAN Speed Indicator

LAN ports are provided by an Advanced Input/Output module (AIOM). One LED on each port indicates the network speed.

LAN LED (Speed Indicator)		
Color	10GbE	25GbE
Green	10 Gb/s	25 Gb/s
Amber	1 Gb/s	10 Gb/s

1.3 System Architecture

Node: Main Components

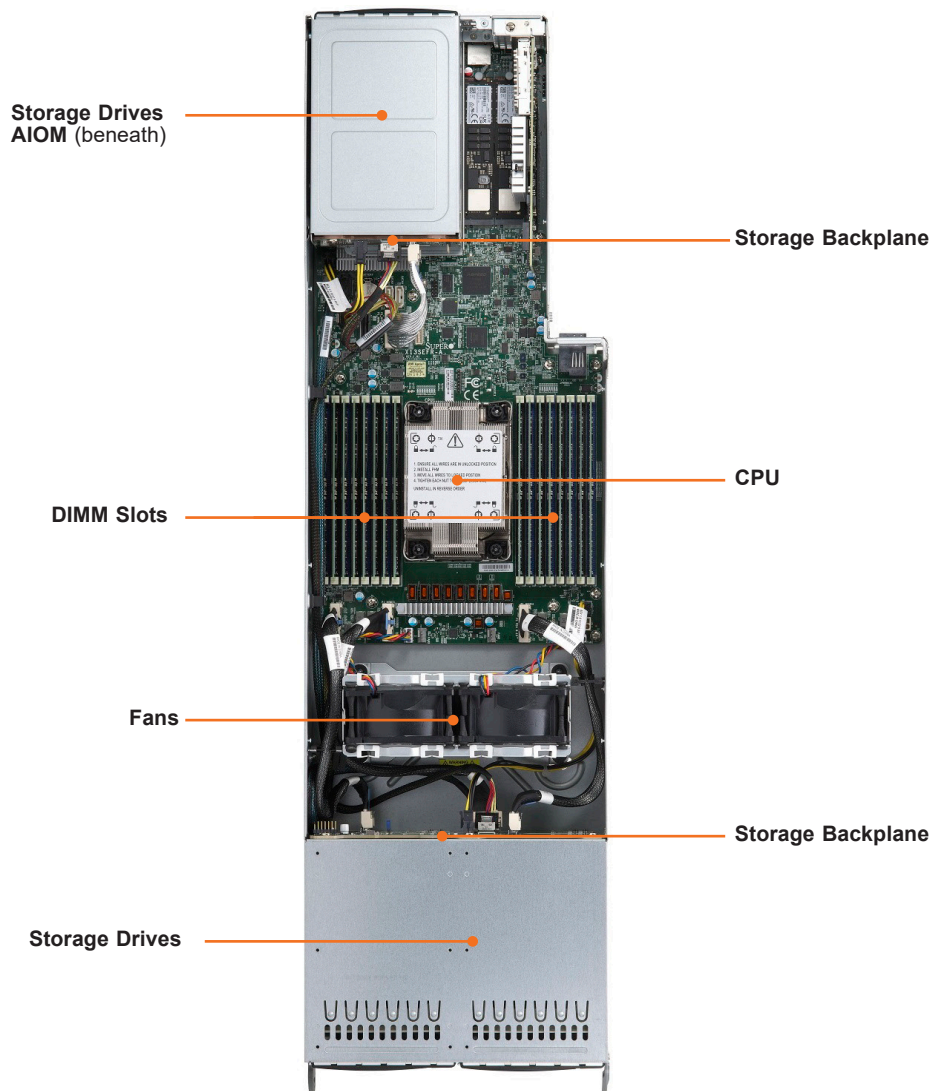

Figure 1-8. Main Component Locations

System Features: Top	
Feature	Description
Storage Backplane	Provides plug-in connections for storage drives
DIMM Slots	Memory module slots
CPU	4th Generation Intel Xeon Scalable processor and heatsink
System Fans	Two 8-cm heavy duty fans

1.4 Motherboard Layout

Below is a layout of the X13SEFR-A motherboard with jumper, connector and LED locations shown. See the table on the following page for descriptions. For detailed descriptions, pinout information and jumper settings, refer to [Chapter 4](#) or the [Motherboard Manual](#).

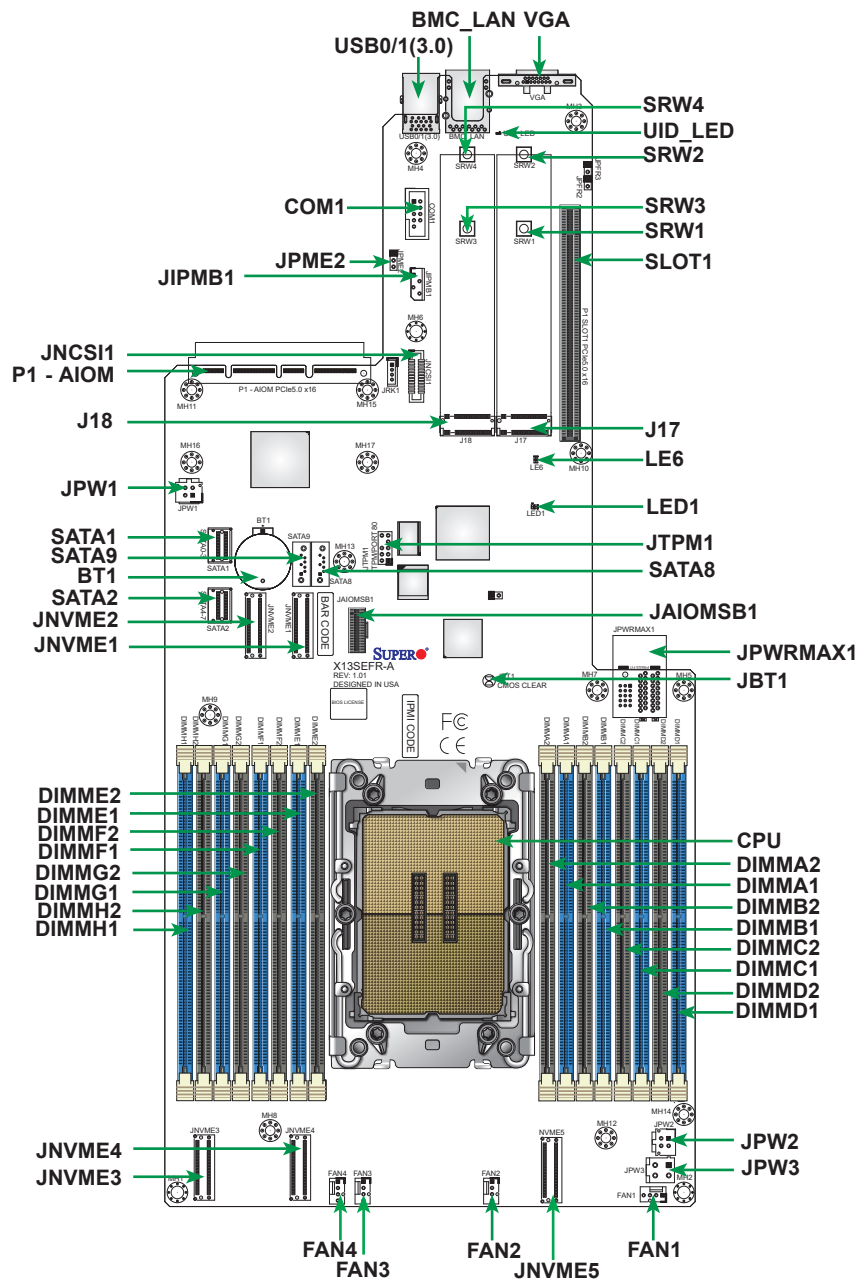

Figure 1-9. Motherboard Layout

Quick Reference

Jumper	Description	Default Setting
JBT1	CMOS Clear	Open (Normal)
JPME2	ME Manufacturing Mode	Pins 1-2 (Normal)

Connector	Description
AIOMSB1	For second AIOM card power and side band signal
BMC_LAN	Dedicated BMC LAN Port
BT1	Onboard Battery
COM1	COM Port Header
FAN1 - FAN4	CPU/System Fan Headers
J17 (M.2-H1), J18 (M.2-H2)	Hybrid M.2 PCIe 3.0 x2 or SATA x1
JIPMB1	System Management Bus Header (for BMC only)
JNCSI1	NCSI Port Connector
JNVME1 - JNVME5	NVMe Connectors
JPW1 - JPW3	Hard Disk Drive Power Headers
JPWRMAX1	Motherboard Power Connector to PDB
JTPM1	Trusted Platform Module/Port 80 Connector
P1 - AIOM	PCIe 5.0 x16
SATA0-3, SATA4-7	Intel PCH SATA 3.0 ports (with RAID 0, 1, 5, 10)
SATA8, SATA9	Intel PCH SATA 3.0 Ports
SLOT1	PCIe 5.0 x16
SRW1-SRW4	M.2 Mounting Holes
USB0/1	Back Panel USB 3.0 Ports
VGA	VGA Port

LED	Description	State: Status
LED1	BMC Heartbeat LED	Blinking Green: BMC Normal
LE6	Power Ready LED	Solid Amber: Standby Solid Red: Power Failed Solid Green: Power On
UID_LED	Unit ID LED	Solid Blue: UID activated locally Blinking Blue: UID activated remotely by BMC

Motherboard Block Diagram

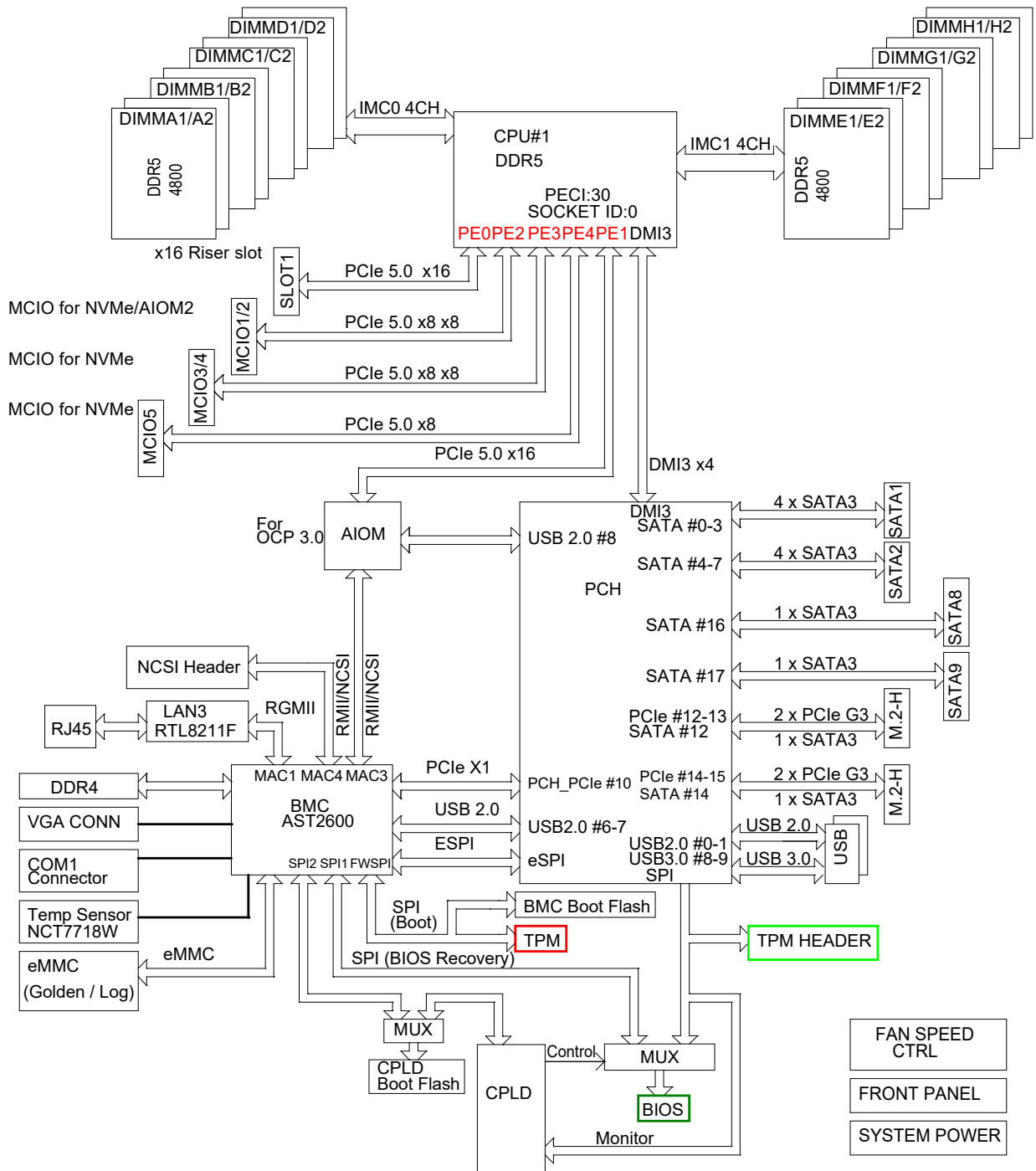

Figure 1-10. Motherboard Block Diagram

Chapter 2

Server Installation

2.1 Overview

This chapter provides advice and instructions for mounting your system in a server rack. If your system is not already fully integrated with processors, system memory etc., refer to [Chapter 3](#) for details on installing those specific components.

Caution: Electrostatic Discharge (ESD) can damage electronic components. To prevent such damage to PCBs (printed circuit boards), it is important to use a grounded wrist strap, handle all PCBs by their edges and keep them in anti-static bags when not in use.

2.2 Unpacking the System

Inspect the box in which the system was shipped, and note if it was damaged. If any equipment appears damaged, file a claim with the carrier.

Decide on a suitable location for the rack unit that will hold the server. It should be situated in a clean, dust-free area that is well ventilated. Avoid areas where heat, electrical noise and electromagnetic fields are generated. It will also require a grounded AC power outlet nearby. Be sure to read the precautions and considerations noted in [Appendix A](#).

2.3 Preparing for Setup

The box in which the system was shipped should include the rackmount hardware needed to install it into the rack. Please read this section in its entirety before you begin the installation.

Choosing a Setup Location

- The system should be situated in a clean, dust-free area that is well ventilated. Avoid areas where heat, electrical noise and electromagnetic fields are generated.
- Leave enough clearance in front of the rack so that you can open the front door completely (~25 inches) and approximately 30 inches of clearance in the back of the rack to allow sufficient space for airflow and access when servicing.
- This product should be installed only in a Restricted Access Location (dedicated equipment rooms, service closets, etc.).

- This product is not suitable for use with visual display workplace devices according to §2 of the German Ordinance for Work with Visual Display Units.

Rack Precautions

- Ensure that the leveling jacks on the bottom of the rack are extended to the floor so that the full weight of the rack rests on them.
- In single rack installations, stabilizers should be attached to the rack. In multiple rack installations, the racks should be coupled together.
- Always make sure the rack is stable before extending a server or other component from the rack.
- You should extend only one server or component at a time - extending two or more simultaneously may cause the rack to become unstable.

Server Precautions

- Review the electrical and general safety precautions in [Appendix A](#).
- Determine the placement of each component in the rack *before* you install the rails.
- Install the heaviest server components at the bottom of the rack first and then work your way up.
- Use a regulating uninterruptible power supply (UPS) to protect the server from power surges and voltage spikes and to keep your system operating in case of a power failure.
- Allow any drives and power supply modules to cool before touching them.
- When not servicing, always keep the front door of the rack and all covers/panels on the servers closed to maintain proper cooling.

Rack Mounting Considerations

Ambient Operating Temperature

If installed in a closed or multi-unit rack assembly, the ambient operating temperature of the rack environment may be greater than the room's ambient temperature. Therefore, consideration should be given to installing the equipment in an environment compatible with the manufacturer's maximum rated ambient temperature (TMRA).

Airflow

Equipment should be mounted into a rack so that the amount of airflow required for safe operation is not compromised.

Mechanical Loading

Equipment should be mounted into a rack so that a hazardous condition does not arise due to uneven mechanical loading.

Circuit Overloading

Consideration should be given to the connection of the equipment to the power supply circuitry and the effect that any possible overloading of circuits might have on overcurrent protection and power supply wiring. Appropriate consideration of equipment nameplate ratings should be used when addressing this concern.

Reliable Ground

A reliable ground must be maintained at all times. To ensure this, the rack itself should be grounded. Particular attention should be given to power supply connections other than the direct connections to the branch circuit (i.e. the use of power strips, etc.).



To prevent bodily injury when mounting or servicing this unit in a rack, you must take special precautions to ensure that the system remains stable. The following guidelines are provided to ensure your safety:

- This unit should be mounted at the bottom of the rack if it is the only unit in the rack.
- When mounting this unit in a partially filled rack, load the rack from the bottom to the top with the heaviest component at the bottom of the rack.
- If the rack is provided with stabilizing devices, install the stabilizers before mounting or servicing the unit in the rack.
- Slide rail mounted equipment is not to be used as a shelf or a work space.

2.4 Procedure for Rack Mounting

This section provides information on installing the chassis into a rack unit with the rails provided. There are a variety of rack units on the market, so the assembly procedure may differ slightly. Also refer to the installation instructions for your rack unit.

Note: This rail will fit a rack between 28" and 33.5" deep.

Overview of the Rack Rails

The package includes two rail assemblies. Each is specifically designed for the left or right side of the chassis, and so marked. Each rail consists of two sections: a front section which secures to the front post of the rack and a rear section which adjusts in length and secures to the rear post of the rack.

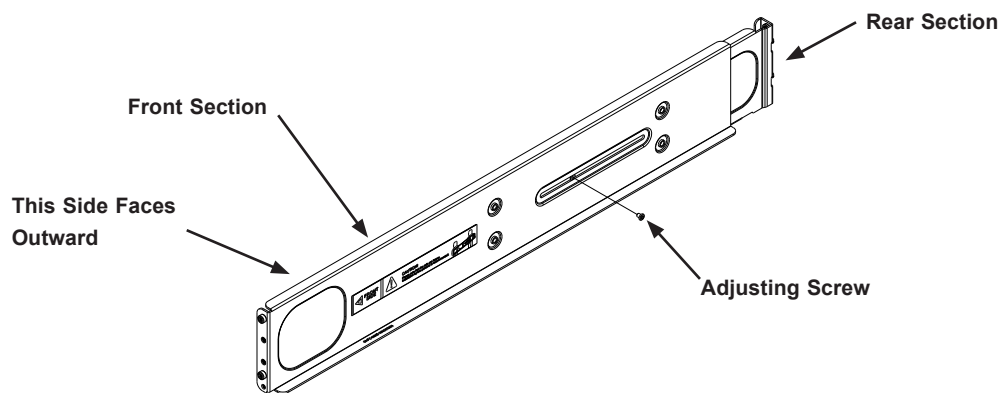

Figure 2-1. Rackmount Rail
(Left Rail assembly shown)

Adjusting the Rails

Each rail assembly has an adjusting screw. Loosen this screw to adjust the length of the rail to fit the depth of your rack.

Installing the Rails on a Rack

Installing the Rails

1. Loosen the adjusting screw to allow the rear section to slide in the front section..
2. Push the small hooks on the front section of the rail into the holes on the front post of the rack and then down, until the spring-loaded pegs snap into the rack holes. Secure the rail to the rack with screws.
3. Pull out the rear section of the outer rail, adjusting the length until it fits within the posts of the rack and align the small hooks with the appropriate holes on the rear post of the rack. Be sure the rail is level.
4. Mount the rear section onto the rack. Secure the rail with screws.

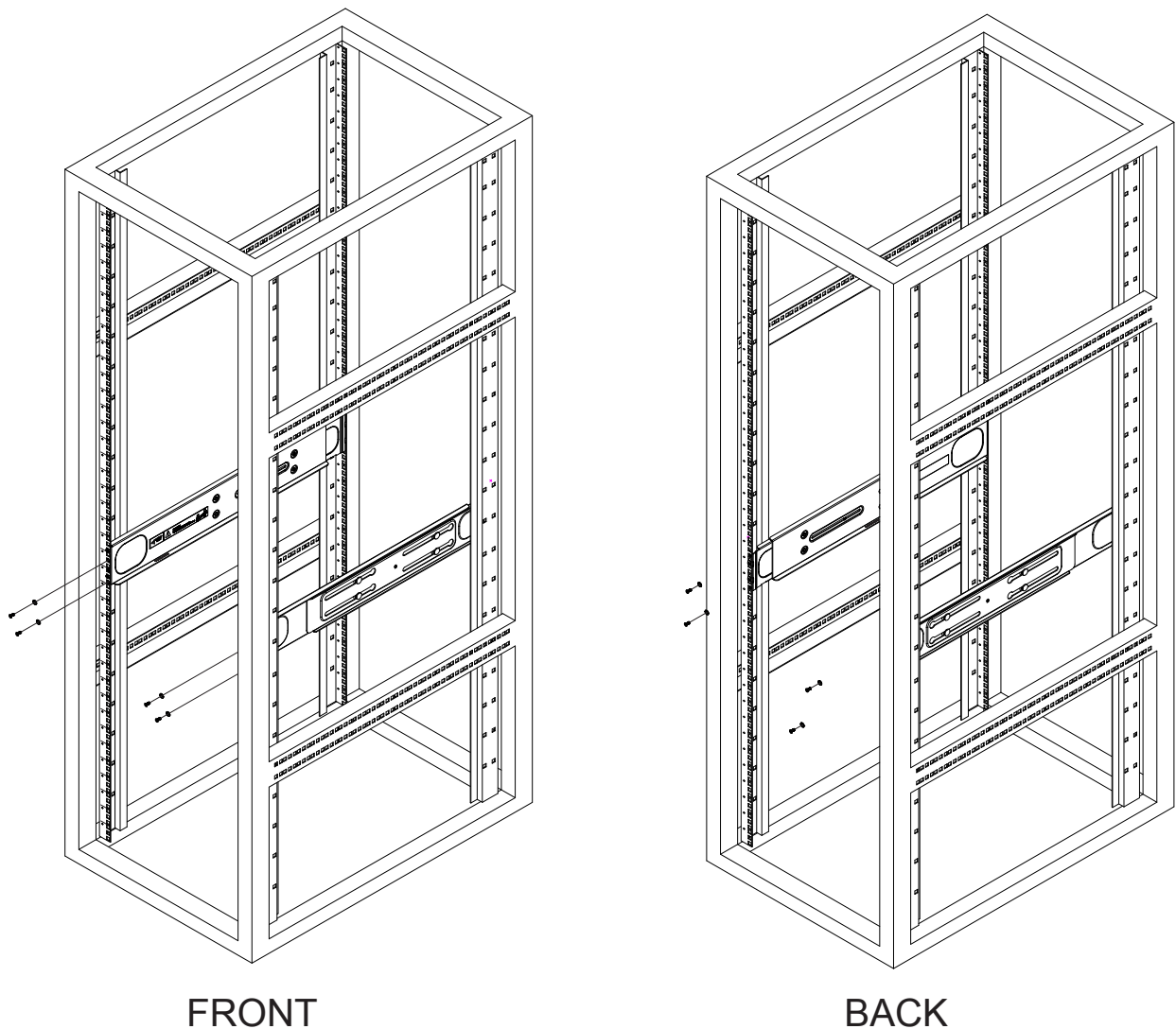

Figure 2-2. Attaching the Rails to a Rack

Note: Figure is for illustrative purposes only. Always install servers to the bottom of a rack first.

Chassis Installation

Slide the chassis into the rack so that the bottom of the chassis slide onto the bottom lip of the rail.

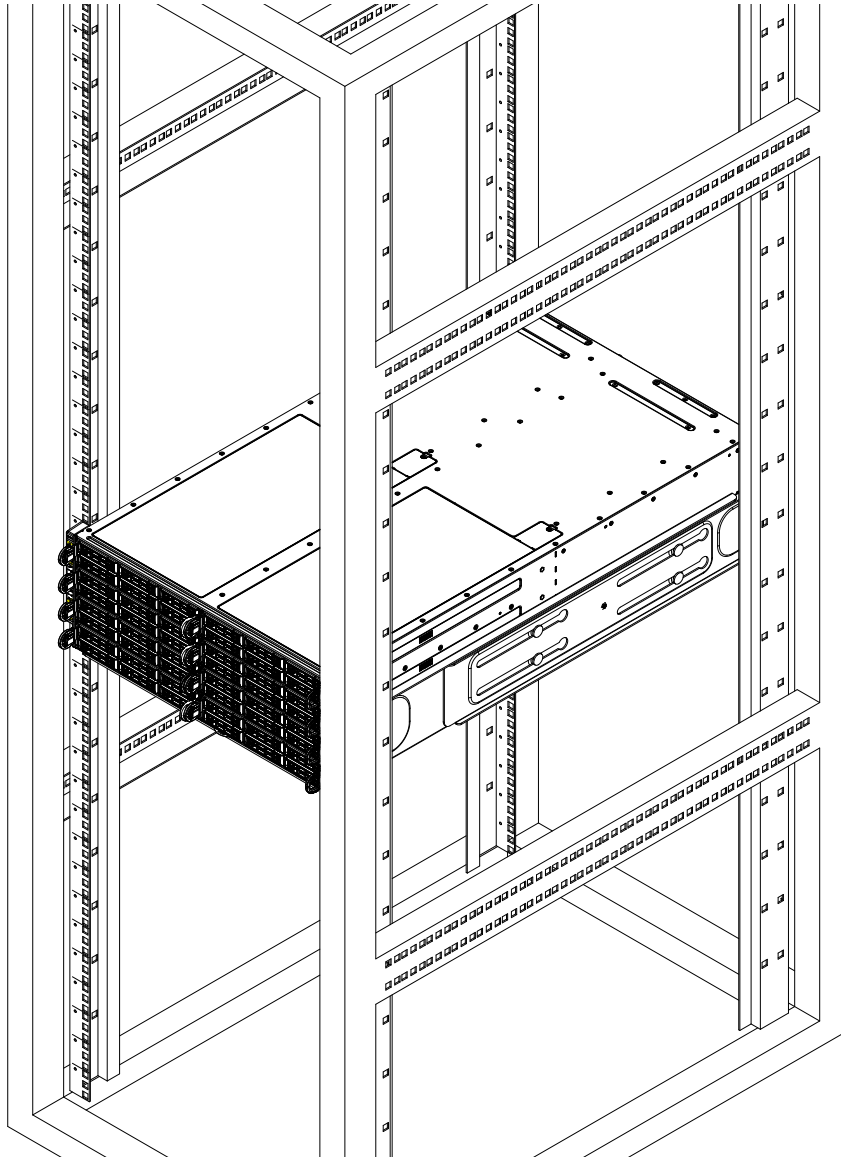

Figure 2-3. Sliding the Chassis into the Rack

Note: Figure is for illustrative purposes only. Always install servers to the bottom of a rack first.



Stability hazard. The rack stabilizing mechanism must be in place, or the rack must be bolted to the floor before you slide the unit out for servicing. Failure to stabilize the rack can cause the rack to tip over. Figure is for illustrative purposes only. Always install servers to the bottom of a rack first.

Do not use a two post "telco" type rack.

Removing the Chassis from the Rack

Caution! It is dangerous for a single person to off-load the heavy chassis from the rack without assistance. Be sure to have sufficient assistance supporting the chassis when removing it from the rack. Use a lift.

1. If necessary, loosen the thumb screws on the front of the chassis that hold it in the rack.
2. Pull the chassis forward out the front of the rack until it stops.
3. Press the release latches on each of the inner rails downward simultaneously and continue to pull the chassis forward and out of the rack.

Chapter 3

Maintenance and Component Installation

This chapter provides instructions on installing and replacing main system components. To prevent compatibility issues, only use components that match the specifications and/or part numbers given.

Installation or replacement of most components require that power first be removed from the system. Please follow the procedures given in each section.

3.1 Removing Power

Remove power from a single node using the operating system.

Removing Power from the System

Use the following procedure to ensure that power has been removed from the system. This step is necessary when removing or installing non hot-swap components or when replacing a non-redundant power supply.

1. Use the operating system to power down all nodes.
2. After the nodes have completely shut-down, disconnect the AC power cords from the power strip or outlet.
3. Disconnect the power cords from the power supply modules.

3.2 Accessing the Nodes

Removing Nodes from the Chassis

Each of the individual nodes may be removed from the chassis. Note that when a node is removed from the chassis, the storage drives located in the node will shut-down.

Removing a Node

1. Power down the node as described in Section 3-1.
2. Grasp the node by the handles on both sides of the front of the node.
3. Press down on the left handle to disengage the latch.
4. While holding down the left handle, pull the node forward and out of the chassis.



Figure 3-1. Removing a Node from the Chassis

Caution: Do not operate the server for a long time with a node drawer removed to assure proper airflow and to prevent overheating.

Removing the Cover from the Node

Removing the Node Cover

1. Remove the screw as shown below.
2. Slide the cover toward the rear of the node until it reaches the unlocked position.
3. Lift the top cover up and off the node.

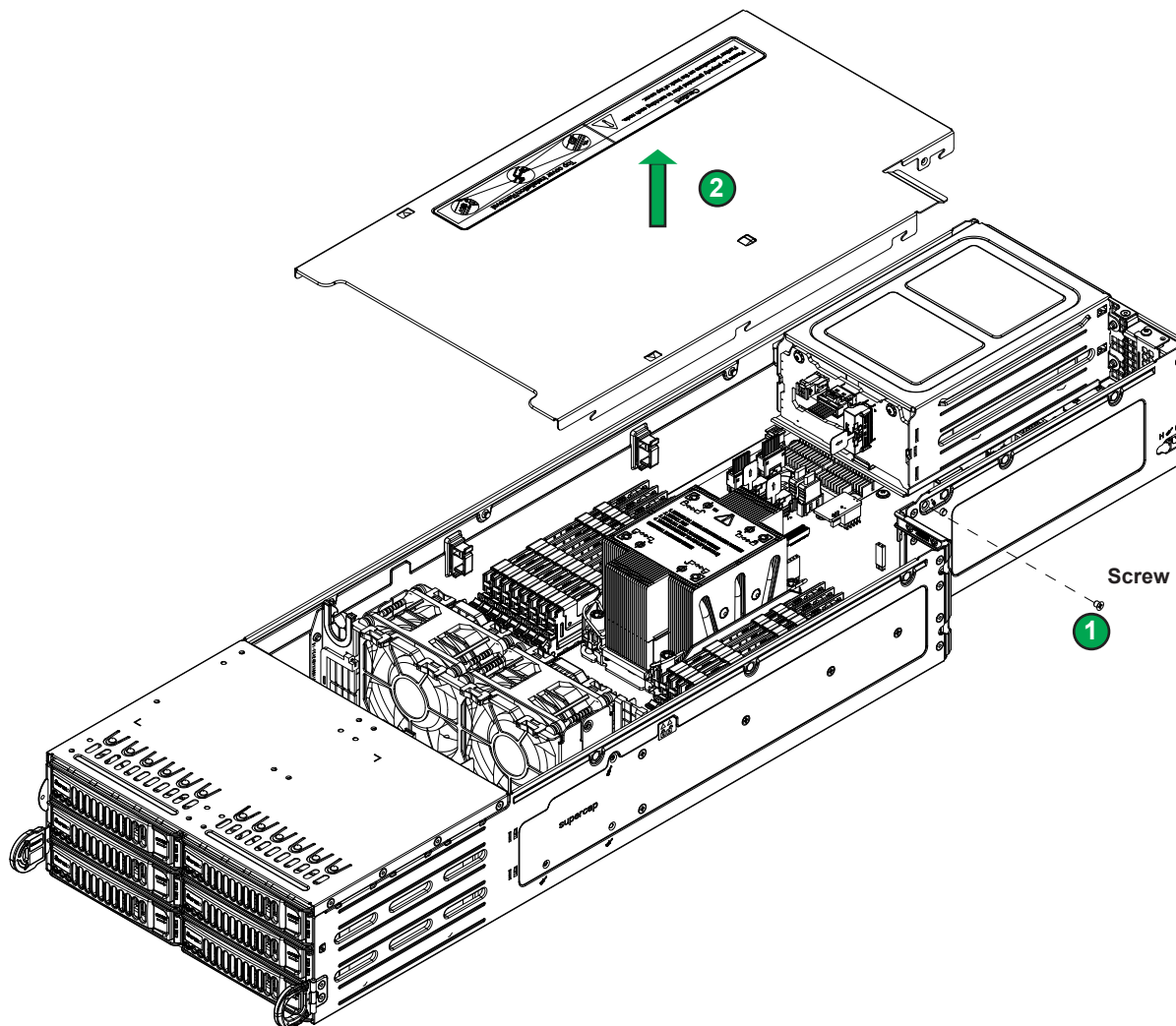
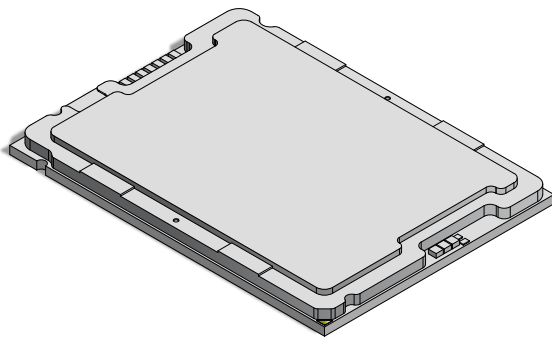

Figure 3-2. Removing the Node Cover

3.3 Processor and Heatsink

Processor Overview

The motherboard supports three versions of the 4th Generation Intel Xeon Scalable processors. They differ in the number of cores, and each requires a different CPU carrier. The XCC version supports up to 60 cores, the MCC version supports up to 32 cores, and the HBM version supports up to 56 cores. The CPU carriers differ by the presence or absence of shims and levers.



SP XCC

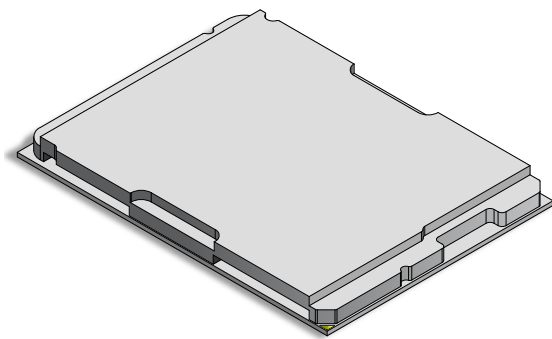

SP MCC

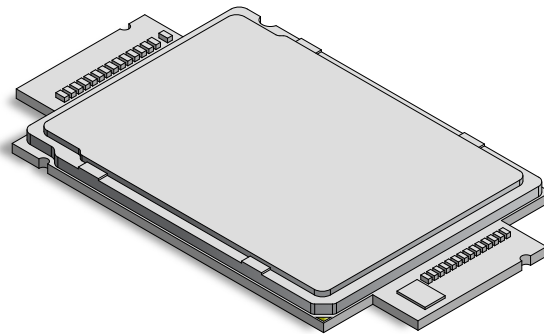

SP HBM

CPU and Carrier Type					
CPU Type	Cores	Carrier Type	Lever	Shim	Carrier Part Number
XCC	60	E1A	Yes	No	SKT-1333L-0000-FXC (alt: SKT-1333L-0001-LTS)
MCC	32	E1B	Yes	Yes	SKT-1424L-001B-FXC (alt: SKT-1424L-001B-LTS)
HBM	56	E1C	No	No	SKT-1425H-001C-FXC (alt: SKT-1425H-001C-LTS)

Installation Overview

The processor (CPU) and processor carrier should be assembled together first to form the processor carrier assembly. This will be attached to the heatsink to form the processor heatsink module (PHM) before being installed onto the CPU socket.

Notes:

- Use ESD protection.
- The system power cords must be removed from all power supplies.
- Check that the plastic protective cover is on the CPU socket and none of the socket pins are bent. If they are, contact your retailer.
- When handling the processor, avoid touching or placing direct pressure on the LGA lands (gold contacts). Improper installation or socket misalignment can cause serious damage to the processor or socket, which may require manufacturer repairs.
- Refer to the Supermicro website for updates on processor support.

Installation Procedure Overview

After preparing the system, and following ESD precautions, there are four steps to installing the processor and heatsink onto the motherboard.

1. Attach the processor to a plastic carrier to create the processor carrier assembly.
2. Attach the processor carrier assembly to the heatsink to create the processor heatsink module (PHM).
3. Remove the socket cover.
4. Install the PHM.

Create the Processor Carrier Assembly

Assembling the Process Carrier Assembly

1. Hold the processor with the gold pins (LGA lands) facing down. Locate the gold triangle at the corner of the processor and the corresponding hollowed triangle on the processor carrier as shown below. These triangles indicate the location of pin 1.

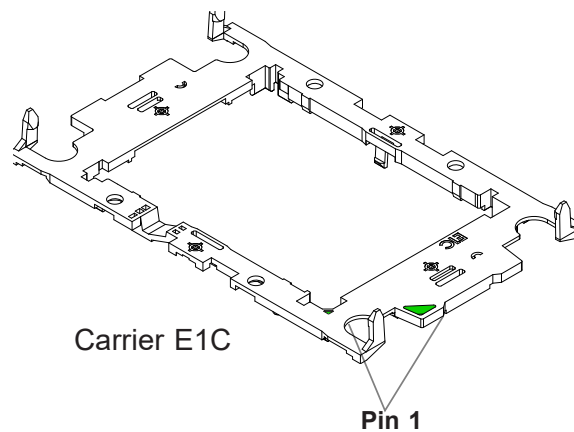
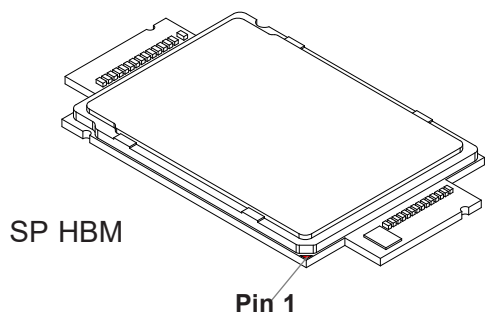
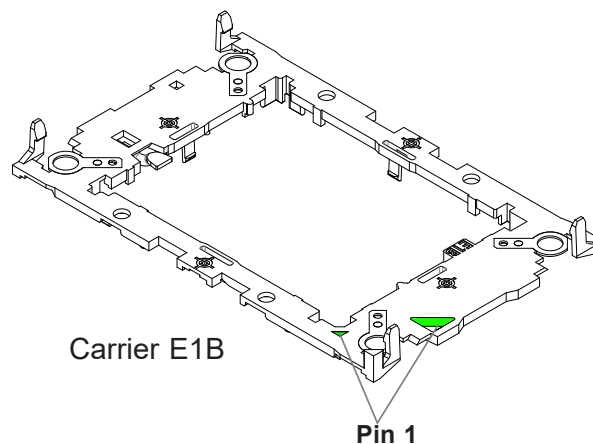
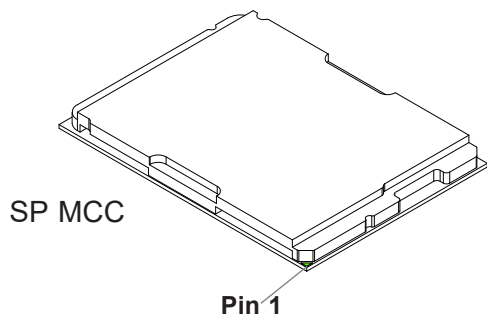
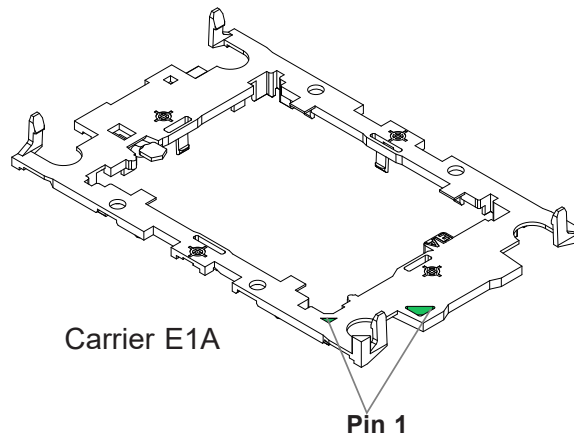
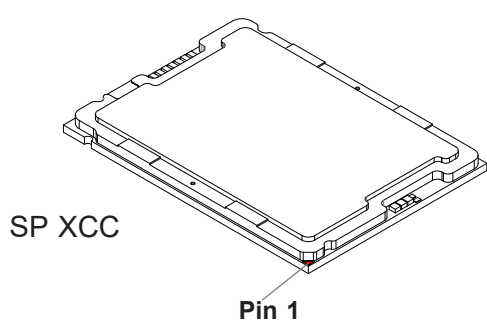

- Turn the processor over (with the gold pins up). Locate the CPU keys on the processor and the four latches on the carrier.

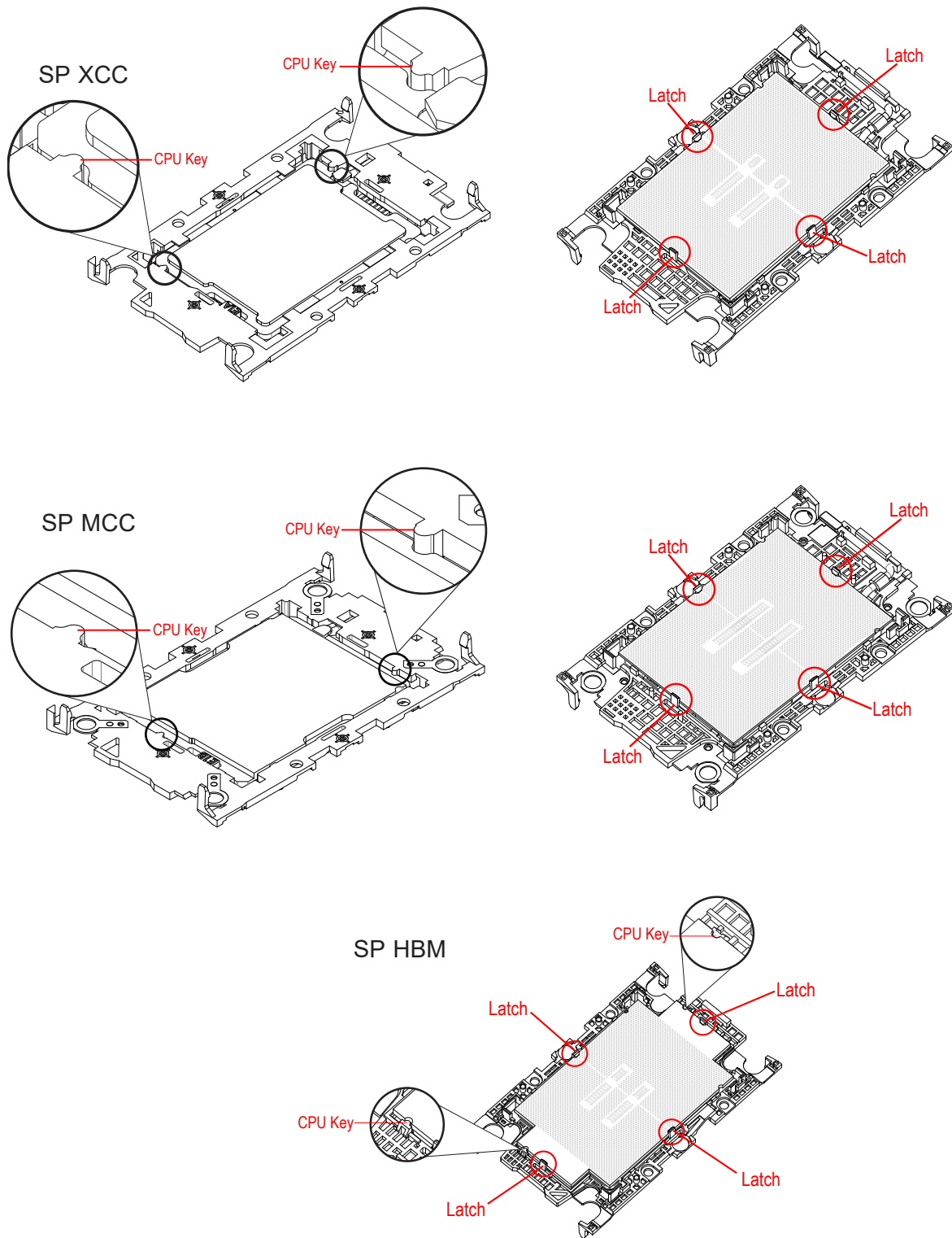

3. Locate the lever on the processor carrier and press it down (E1A and E1B only).

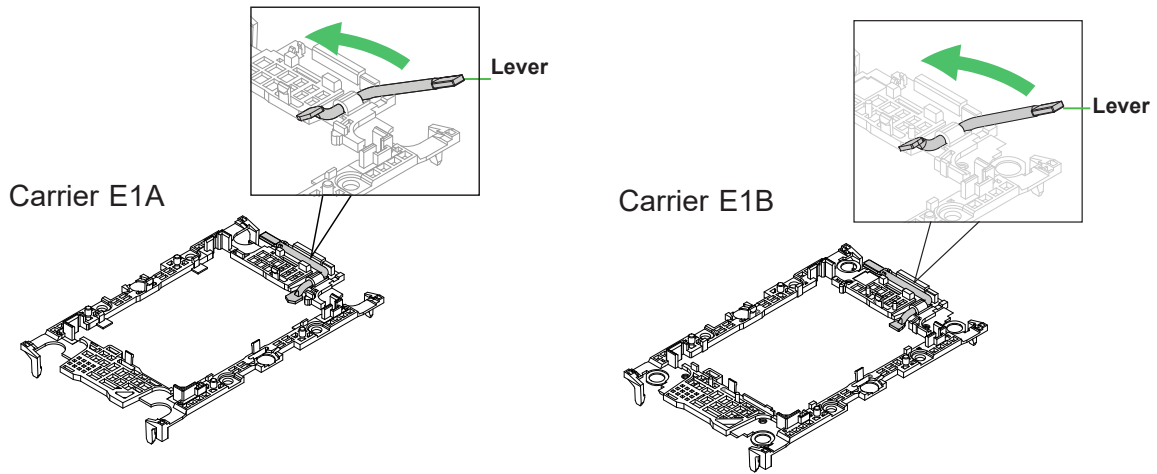

4. Using pin 1 as a guide, carefully align the CPU keys on the processor (A & B) with those on the carrier (a & b).

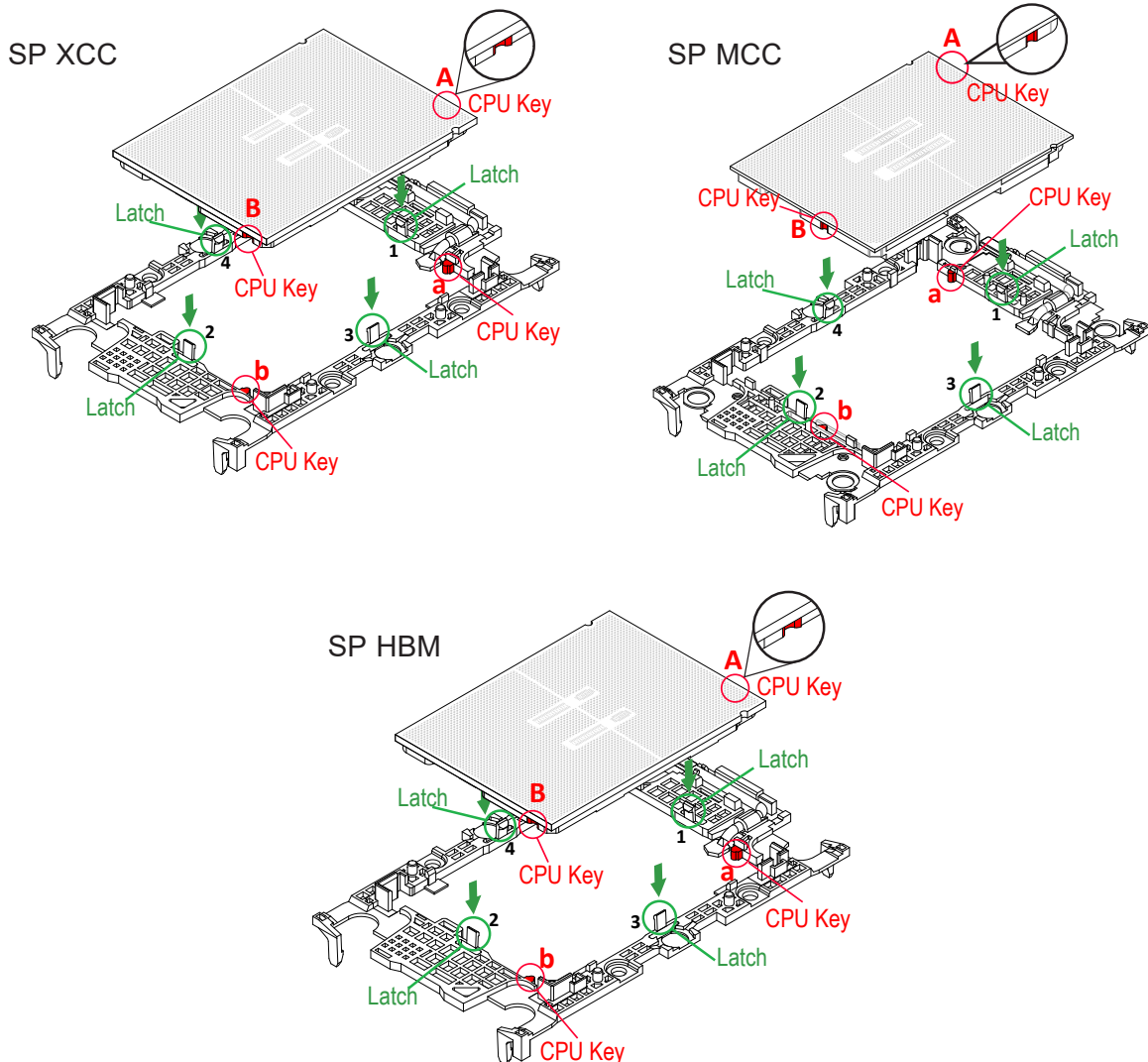

5. Once aligned, carefully insert the CPU into the carrier, making sure that the CPU is secured by latches 1, 2, 3, and 4.

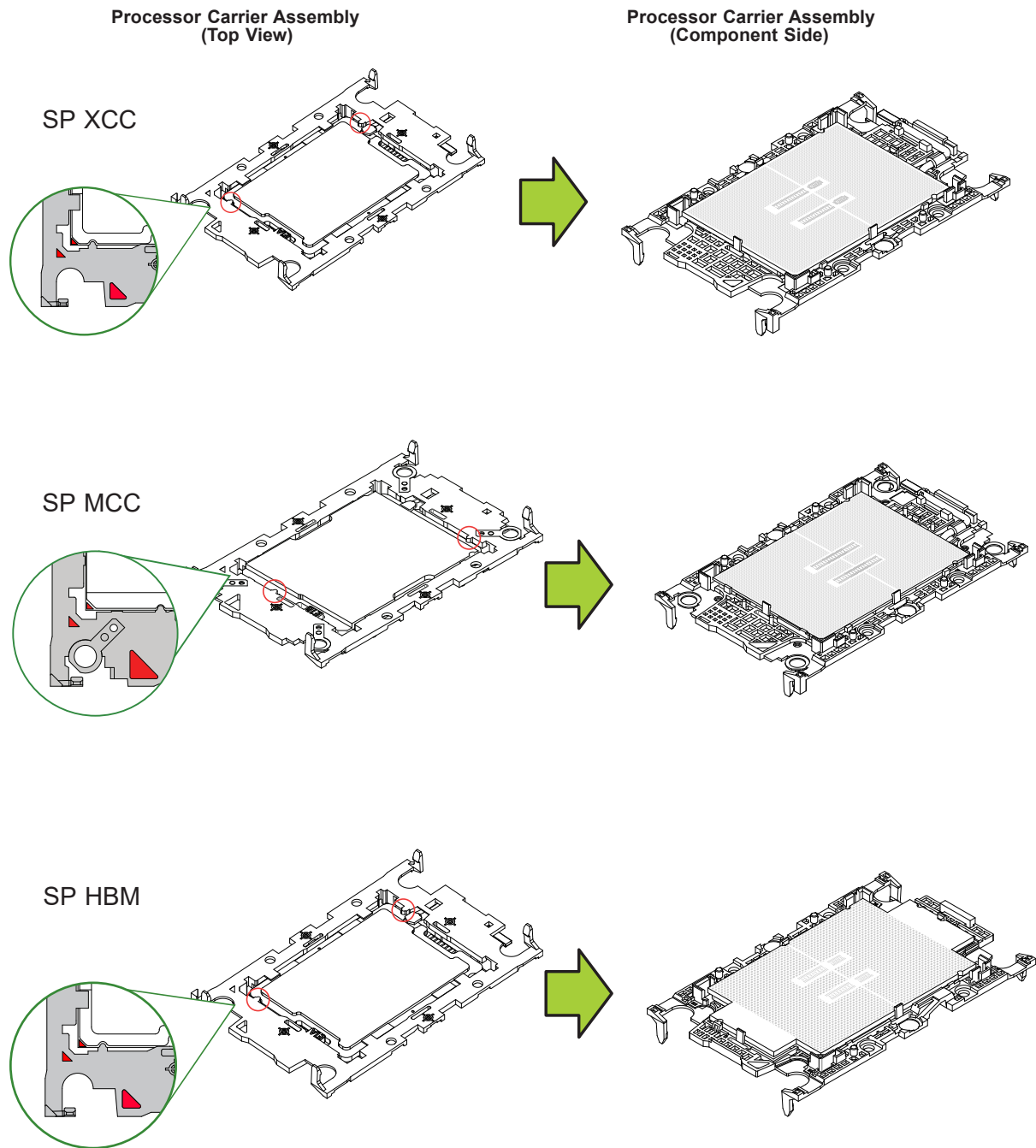

Assemble the Processor Heatsink Module

Thermal grease is pre-applied on a new heatsink. No additional thermal grease is needed. If this is a re-installation, apply the proper amount of thermal grease to the underside of the heatsink.

Assembling the Processor Heatsink Module (PHM)

1. Turn the heatsink over with the thermal grease facing up. Locate the two triangle cutouts (A, B) at the diagonal corners of the heatsink as shown in the drawing below.
2. Hold the processor carrier assembly component side up to locate the triangles on the processor and the carrier, which indicate pin 1.
3. Turn the processor carrier assembly over so that the gold pins are facing up, noting the two pin 1 locations ("A" on the processor and "a" on the processor carrier assembly).

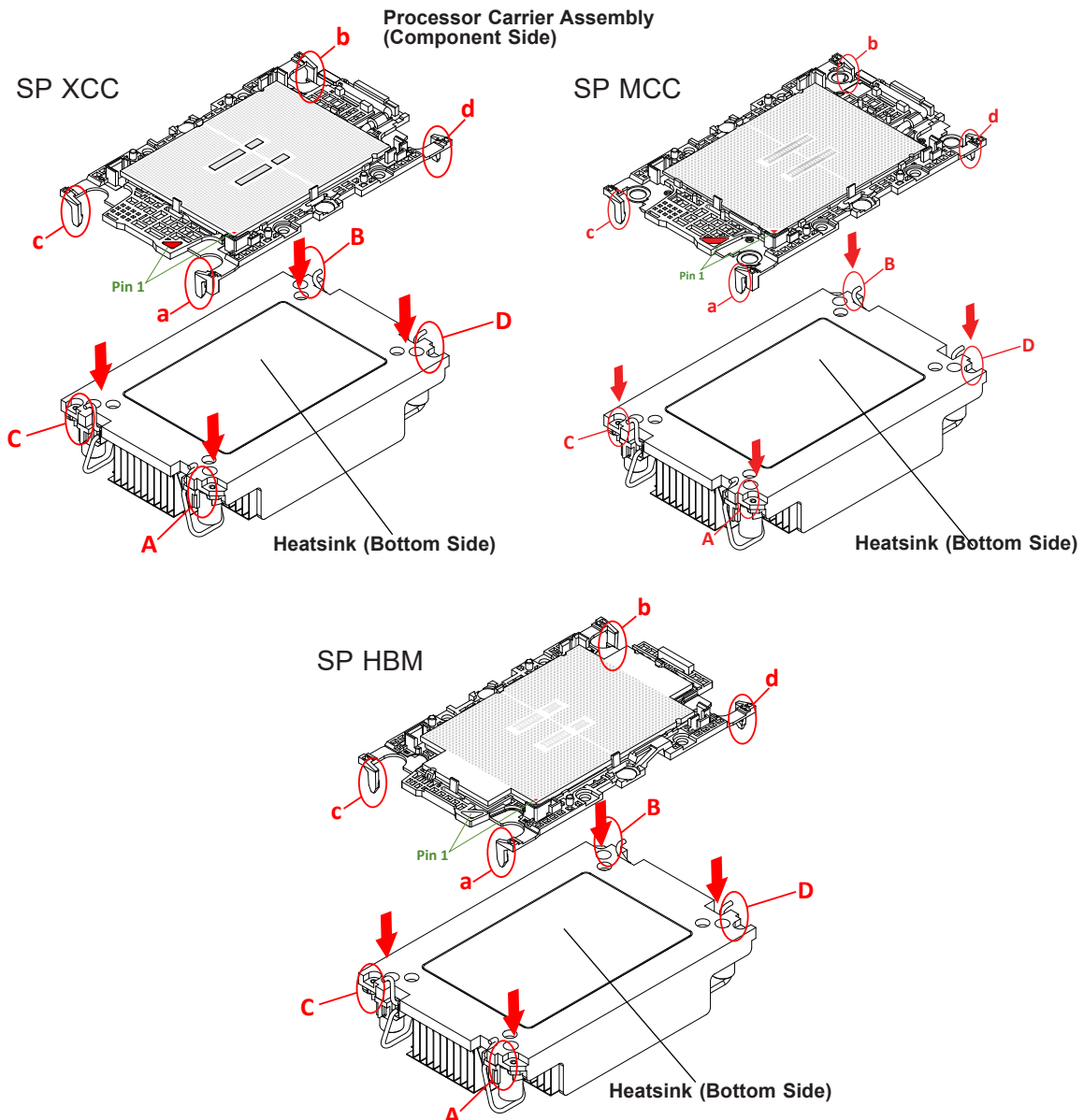

4. Align "a" on the processor carrier assembly with the triangular cutout "A" on the heatsink along with "b", "c", "d" on the processor assembly with "B", "C", "D" on the heatsink.
5. Once properly aligned, place the heatsink on the processor carrier assembly with all corners matched up, making sure that the four clips are properly securing the heatsink.

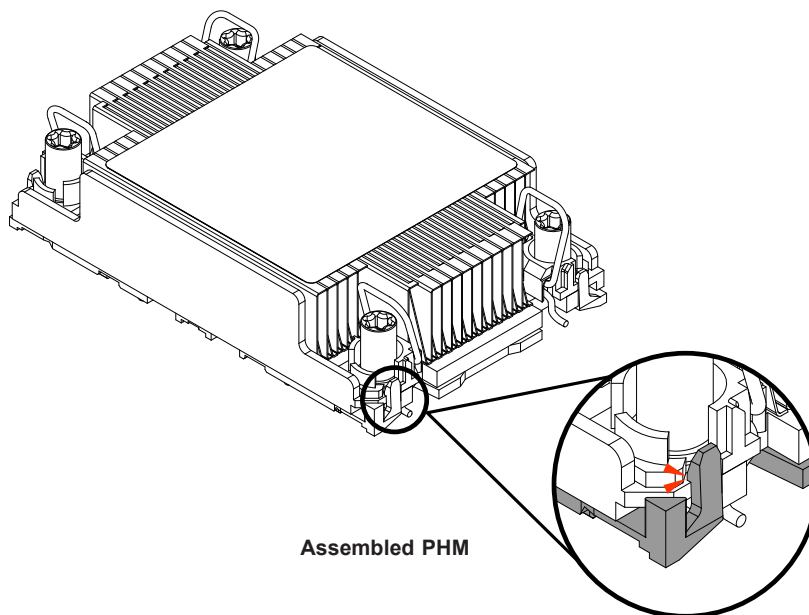

Note: The figure is for illustrative purposes. Your components may differ slightly from the components shown.

Remove the Socket Cover

Remove the plastic protective cover from the socket by gently squeezing the grip tabs and pulling the cover off.

CPU Socket with Plastic Protective Cover

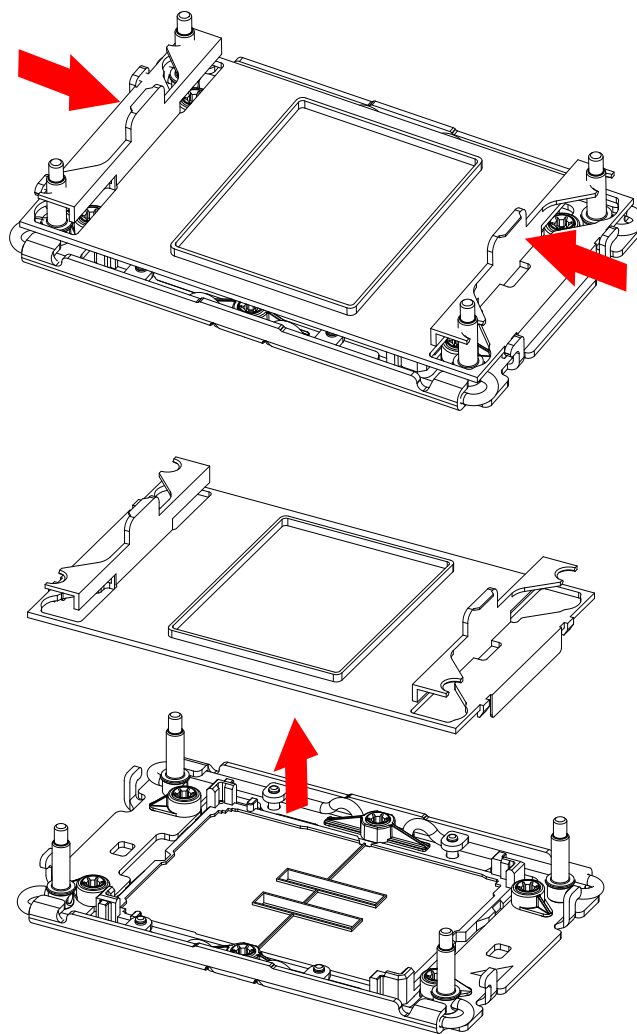

Install the PHM

To install the PHM into the CPU socket, follow these steps.

1. Locate four threaded fasteners (a, b, c, d) and Pin 1 on the CPU socket.

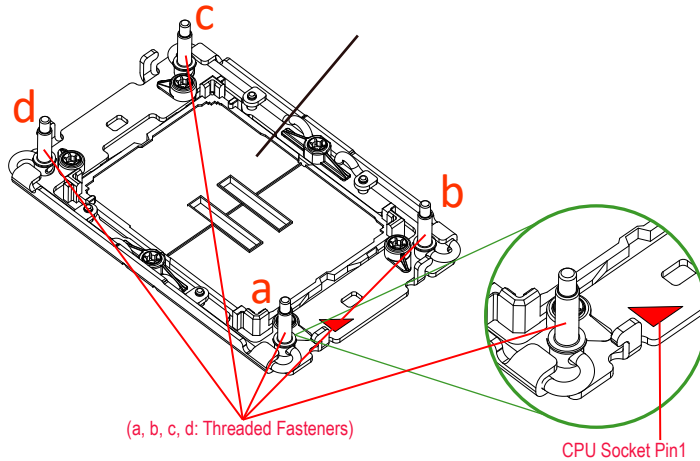

2. Locate four PEEK nuts (A, B, C, D) and four rotating wires (1, 2, 3, 4) on the heatsink.

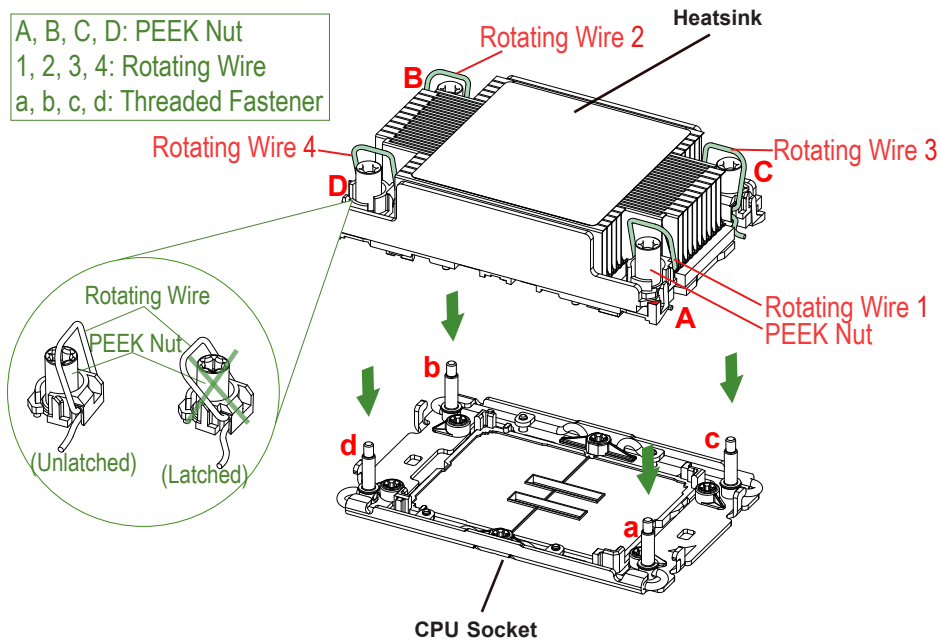

3. Check the rotating wires (1, 2, 3, 4) to make sure that they are in the unlatched position.

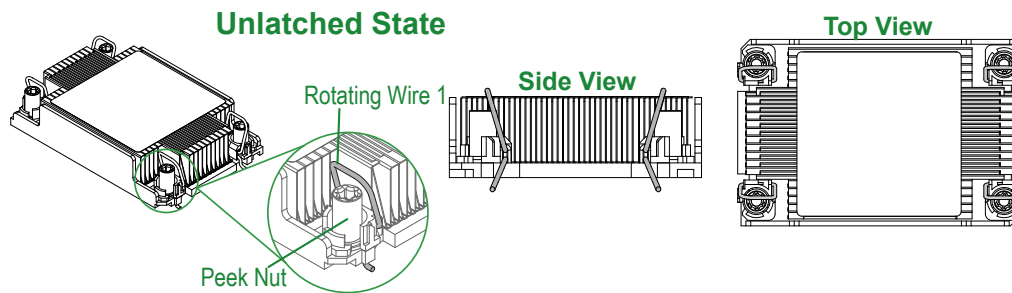

4. Align PEEK nut "A" (next to the triangular pin 1 on the heatsink) with threaded fastener "a" on the CPU socket. Then align PEEK nuts "B", "C", "D" on the heatsink with threaded fasteners "b", "c", "d" on the CPU socket.
5. Once aligned, gently place the PHM on the CPU socket, making sure that each PEEK nut is properly attached to its corresponding threaded fastener.

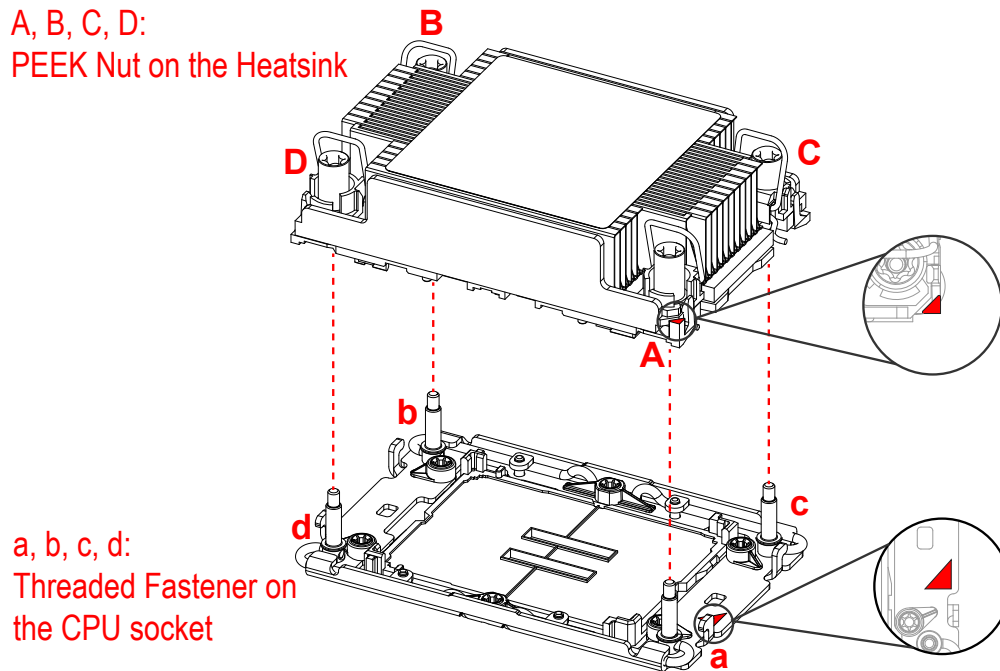

6. Press all four rotating wires outward and make sure that the heatsink is securely latched into the CPU socket.

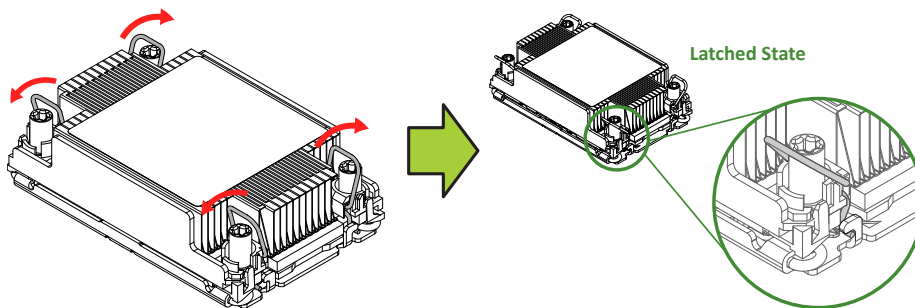

7. With a t30-bit screwdriver, tighten all PEEK nuts in the sequence of "A", "B", "C", and "D" with even pressure. Note the torque specifications written on the heatsink, and do not exceed them when tightening the screws.
8. Examine all corners of the heatsink to ensure that the PHM is firmly attached to the CPU socket.

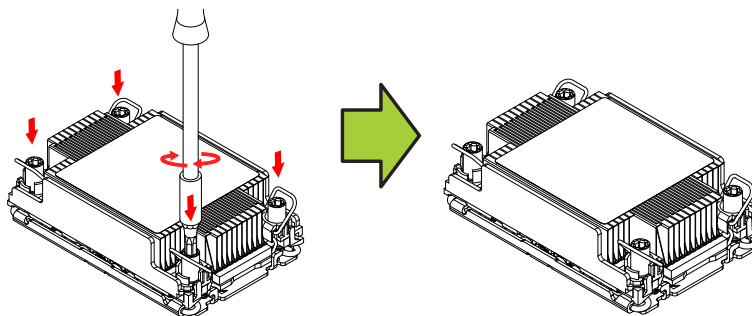

Removing the Processor

Removing the PHM

To remove the processor heatsink module (PHM) from the motherboard, follow these steps.

1. Shut down the system and unplug the AC power cord from all power supplies.
2. Use a T30-bit screwdriver to loosen the four PEEK nuts on the heatsink in the sequence of A, B, C, and D.

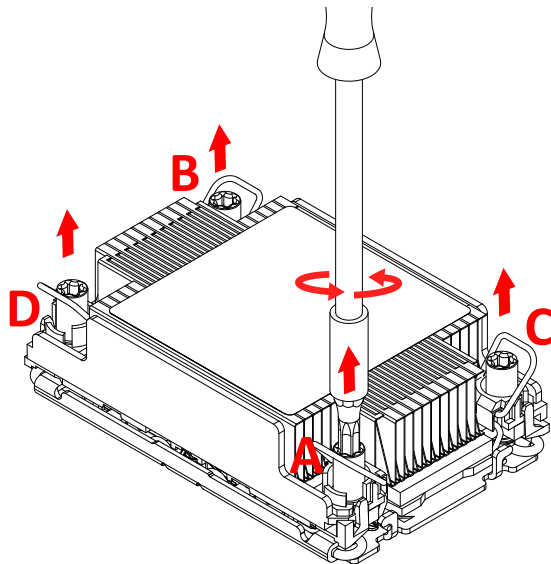

3. Press the rotating wires inward to unlatch the PHM from the socket as shown below.

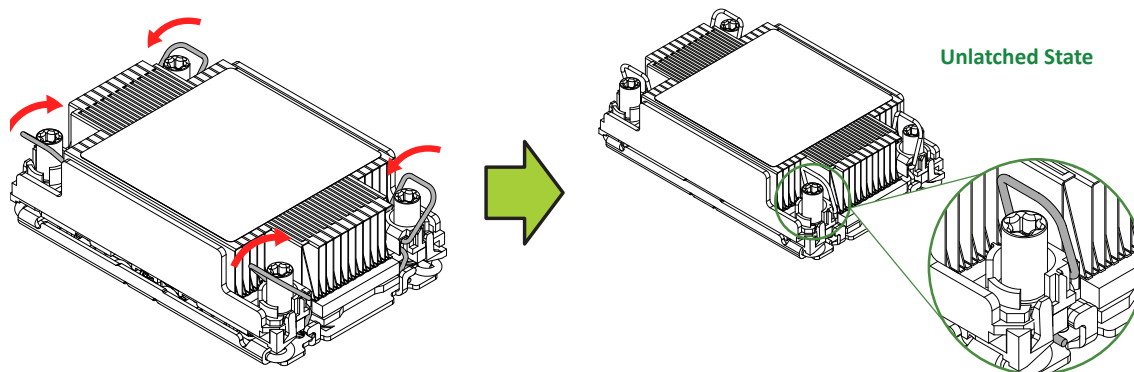

4. Gently lift the PHM upward to remove it from the CPU socket.

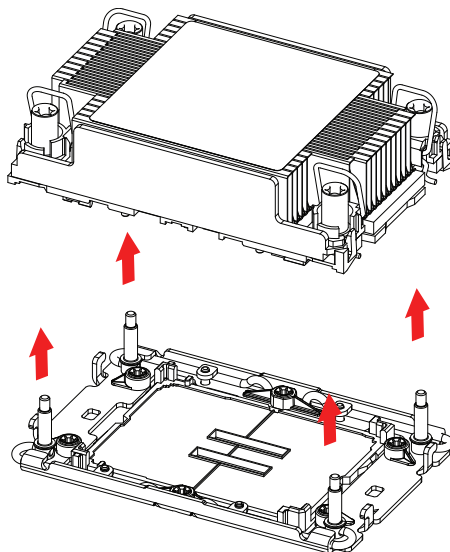

Removing the Carrier Assembly from the Heatsink

To remove the processor carrier assembly from the PHM, follow these steps:

1. Detach the four plastic clips (marked a, b, c, d) on the processor carrier assembly from the four corners of the heatsink (marked A, B, C, D) as shown below.

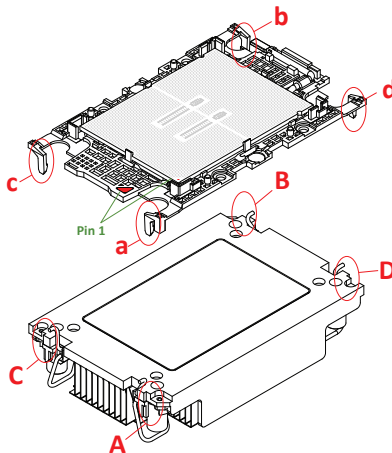

2. When all plastic clips have been detached from the heatsink, remove the processor carrier assembly from the heatsink

Removing the Processor from the Carrier Assembly

To remove the processor from the processor carrier, follow these steps.

1. Unlock the lever from its locked position and push it upwards to disengage the processor from the processor carrier as shown below right.

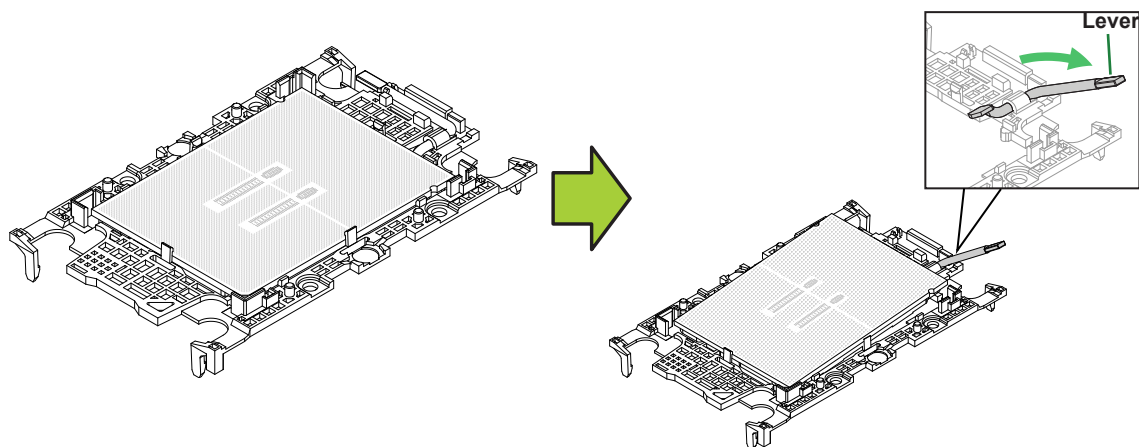

2. Once the processor has been loosened from the carrier, carefully remove the processor from the carrier.

Note: Handle the processor with care.

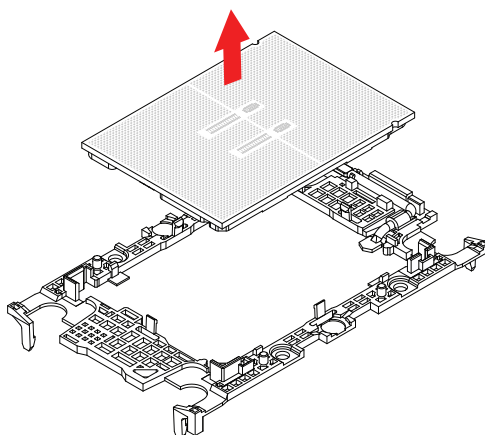

3.4 Memory

Memory Support

This motherboard supports up to 4TB of ECC RDIMM/3DS RDIMM DDR5 memory with speeds of up to 4800MT/s (DDR5-4400MT/s when fully populated) in 16 memory slots with eight channels. For validated memory, see the [system product page](#).

DDR5 Memory Support 4th Generation Intel Xeon Scalable Processor				
Type	Ranks Per DIMM and Data Width (Stack)	DIMM Capacity (GB)	Speed (MT/s)	
			One DIMM per Channel	Two DIMMs per Channel
		16 Gb	1.1 Volts	
RDIMM	1Rx8 (RC D)	16GB	4800*	4400*
	1Rx4 (RC C)	32GB		
	1Rx5 (RC F) 9x4	32GB		
	2Rx8 (RC E)	32GB		
	2Rx4 (RC A))	64GB		
	2Rx4 (RC B) 9x4	64GB		
RDIMM 3DS	(4R/8R) x4 (RC A)	2H-128 GB		
		4H-256 GB		

*Memory speed and capacity support depends on the processors used in the system.

Use the DIMM slots listed below for memory modules. This memory population table is based on guidelines provided by Intel to support Supermicro motherboards.

Memory Population for 16 DIMM Slots	
DIMMs	Slots
1 DIMM	A1 or B1 or E1 or F1
2 DIMMs	A1 and G1, or C1 and E1
4 DIMMs	A1, C1, E1, G1
6 DIMMs	A1, C1, D1, E1, F1, G1 or A1, B1, C1, E1, G1, H1 or B1, C1, D1, E1, F1, H1 or A1, B1, D1, F1, G1, H1
8 DIMMs	A1, B1, C1, D1, E1, F1, G1, H1
12 DIMMs	A1, A2, B1, C1, C2, D1, E1, E2, F1, G1, G2, H1 or A1, B1, B2, C1, D1, D2, E1, F1, F2, G1, H1, H2
16 DIMMs	A1, A2, B1, B2, C1, C2, D1, D2, E1, E2, F1, F2, G1, G2, H1, H2

HBM CPU, Memory Population for 16 DIMM Slots	
DIMMs	Slots
0	
1 DIMM	A1 or E1
2 DIMMs	A1 and G1, or C1 and E1
4 DIMMs	A1, C1, E1, G1
8 DIMMs	A1, B1, C1, D1, E1, F1, G1, H1
16 DIMMs	A1, A2, B1, B2, C1, C2, D1, D2, E1, E2, F1, F2, G1, G2, H1, H2

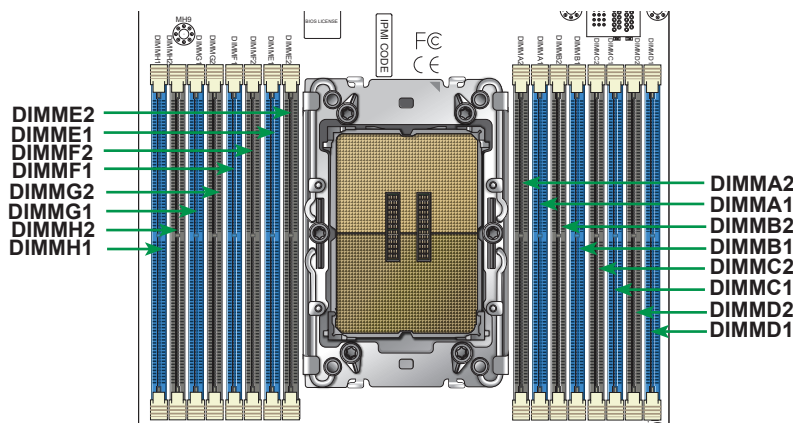

Figure 3-4. Memory Slots

Memory Population Guidelines

- All DIMMs must be DDR5.
- Balanced memory. Using unbalanced memory topology, such as populating two DIMMs in one channel while populating one DIMM in another channel, reduces performance. It is not recommended for Supermicro systems.

Guidelines Regarding Mixing DIMMs

- Populating slots with a pair of DIMM modules of the same type and size results in interleaved memory, which improves memory performance.
- Use memory modules of the same type and speed, as mixing is not allowed.
- x4 and x8 DIMMs can be mixed in the same channel.
- Mixing of LRDIMMs and RDIMMs is not allowed in the same channel, across different channels, and across different sockets. No mixing of PMem and NVDIMMs within the platform.
- Mixing of non-3DS and 3DS LRDIMM is not allowed in the same channel, across different channels, and across different sockets.

DIMM Construction

- RDIMM (*non-3DS*) Raw Cards: A/B (2Rx4), C (1Rx4), D (1Rx8), E (2Rx8)
- 3DS RDIMM Raw Cards: A/B (4Rx4)
- LRDIMM (*non-3DS*) Raw Cards: D/E (4Rx4)
- 3DS LRDIMM Raw Cards: A/B (8Rx4)

Memory Population Sequence

Blue slots versus black slots: Install the first DIMM in the blue memory slot, which is the first of a memory channel. Then, if using two DIMMs per channel, install the second DIMM in the black slot.

Installing Memory

Electrostatic Discharge (ESD) can damage electronic components including memory modules. To avoid damaging DIMM modules, it is important to handle them carefully. The following measures are generally sufficient.

- Use a grounded wrist strap designed to prevent static discharge.
- Handle the memory module by its edges only.
- Put the memory modules into the antistatic bags when not in use.

Installing Memory

Begin by removing power from the system as described in Section 3.1. Follow the memory population sequence in the table above.

1. Push the release tabs outwards on both ends of the DIMM slot to unlock it.

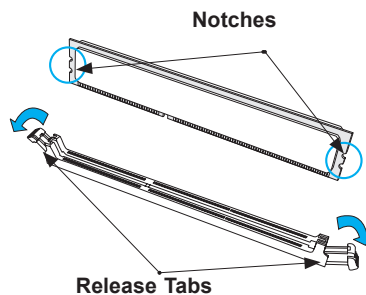

2. Align the key of the DIMM with the receptive point on the memory slot and with your thumbs on both ends of the module, press it straight down into the slot until the module snaps into place.

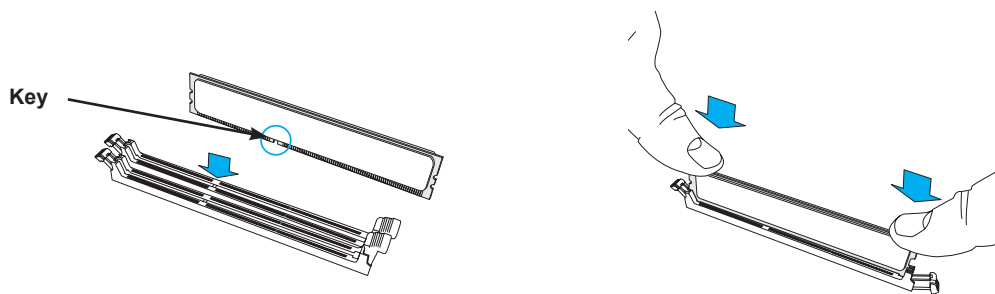

3. Press the release tabs to the locked position to secure the DIMM module into the slot.

Caution: Exercise extreme caution when installing or removing memory modules to prevent damage to the DIMMs or slots.

Removing Memory

To remove a DIMM, unlock the release tabs then pull the DIMM from the memory slot.

3.5 Motherboard Battery

The motherboard uses non-volatile memory to retain system information when system power is removed. This memory is powered by a lithium battery residing on the motherboard.

Replacing the Battery

Begin by [removing power](#) from the system.

1. Push aside the small clamp that covers the edge of the battery. When the battery is released, lift it out of the holder.
2. To insert a new battery, slide one edge under the lip of the holder with the positive (+) side facing up. Then push the other side down until the clamp snaps over it.

Note: Handle used batteries carefully. Do not damage the battery in any way; a damaged battery may release hazardous materials into the environment. Do not discard a used battery in the garbage or a public landfill. Please comply with the regulations set up by your local hazardous waste management agency to dispose of your used battery properly.

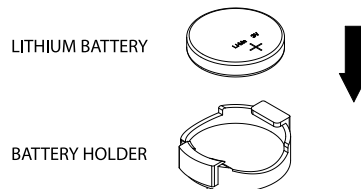

Figure 3-5. Installing the Onboard Battery

Warning: There is a danger of explosion if the onboard battery is installed upside down (which reverses its polarities). This battery must be replaced only with the same or an equivalent type recommended by the manufacturer (CR2032).

3.6 Storage Drives



Each node in the system supports six 3.5" front hot-swap drive bays and two 3.5" rear hot-swap drive bays. The rear bays can be converted to 2.5" drives. Two M.2 NVMe slots are also available on the motherboard. For compatible storage drives, see the [product page](#).

The drives are mounted in toolless drive carriers that simplify their removal from the chassis. These carriers also help promote proper airflow.

Note: Enterprise level hard disk drives are recommended for use in Supermicro chassis and servers. For information on recommended HDDs, visit the Supermicro website [product page](#).

Drive Layout Configurations

NVMe, SAS and SATA drives may be used in combination within each node. SAS and SATA drives may be added in any configuration/order. However, when using a combination of SAS/SATA with NVMe drives, they should be installed in the configurations shown on the following page. Each configuration requires a distinct NVMe kit and cable.

Drive Layout Configuration Legend	
Color	Description
Green 	NVMe Drive
Orange 	SAS or SATA Drive

0 NVMe / 8 SAS/SATA drives



Front Drives



Rear Drives

2 NVMe / 6 SAS/SATA drives



Front Drives



Rear Drives

4 NVMe / 4 SAS/SATA drives



6 NVMe / 2 SAS/SATA drives



8 NVMe / 0 SAS/SATA drives



Installing and Removing the Storage Drives

Removing Rear Drive Carriers from the Node

1. Press the release button on the drive carrier. This extends the drive bay handle.
2. Use the handle to pull the drive carrier out of the chassis.

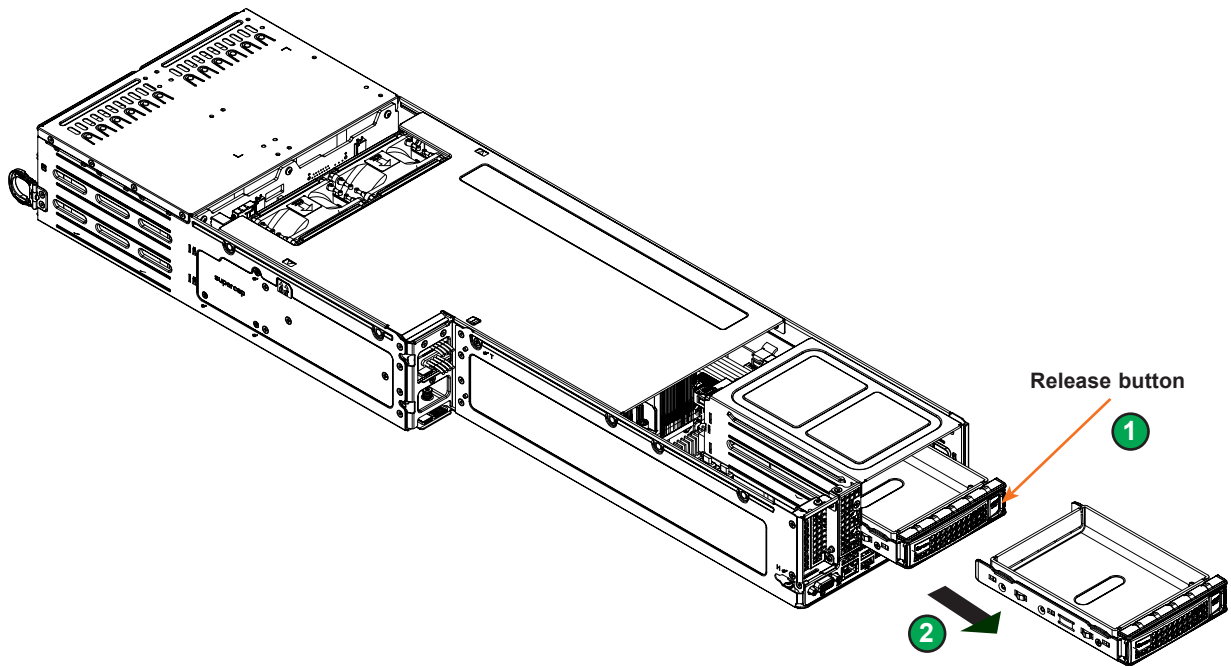

Figure 3-6. Removing a Rear Storage Drive Carrier

Installing a Drive into a Drive Carrier

1. Insert a drive into the carrier with the PCB side facing down and the connector end toward the rear of the carrier.
2. Align the drive in the carrier so that the screw holes of both line up. Note that there are holes in the carrier marked “SATA” to aid in correct installation.
3. Secure the drive to the carrier with four screws.
4. Insert the drive carrier into its bay, keeping the carrier oriented so that the hard drive is on the top of the carrier and the release button is on the right side. When the carrier reaches the rear of the bay, the release handle will retract.
5. Push the handle in until it clicks into its locked position.

Note: Your operating system must have RAID support to enable the hot-plug capability of the hard drives.

Installing a Hard Drive Cage

The rear hard drives reside in a drive cage that fits into the rear section of a node. Follow the procedure below and refer to the corresponding figure on the following page for installing the cage into a node.

1. Locate the insertion stud on the cage and the hole in the node that receives the stud.
2. With the stud and the hole aligned vertically, lower the cage into the node until the stud fits into the hole.
3. Slide the cage toward the rear end of the node to seat the stud in its hole.
4. Secure the cage to the node with screws in the locations noted in the figures

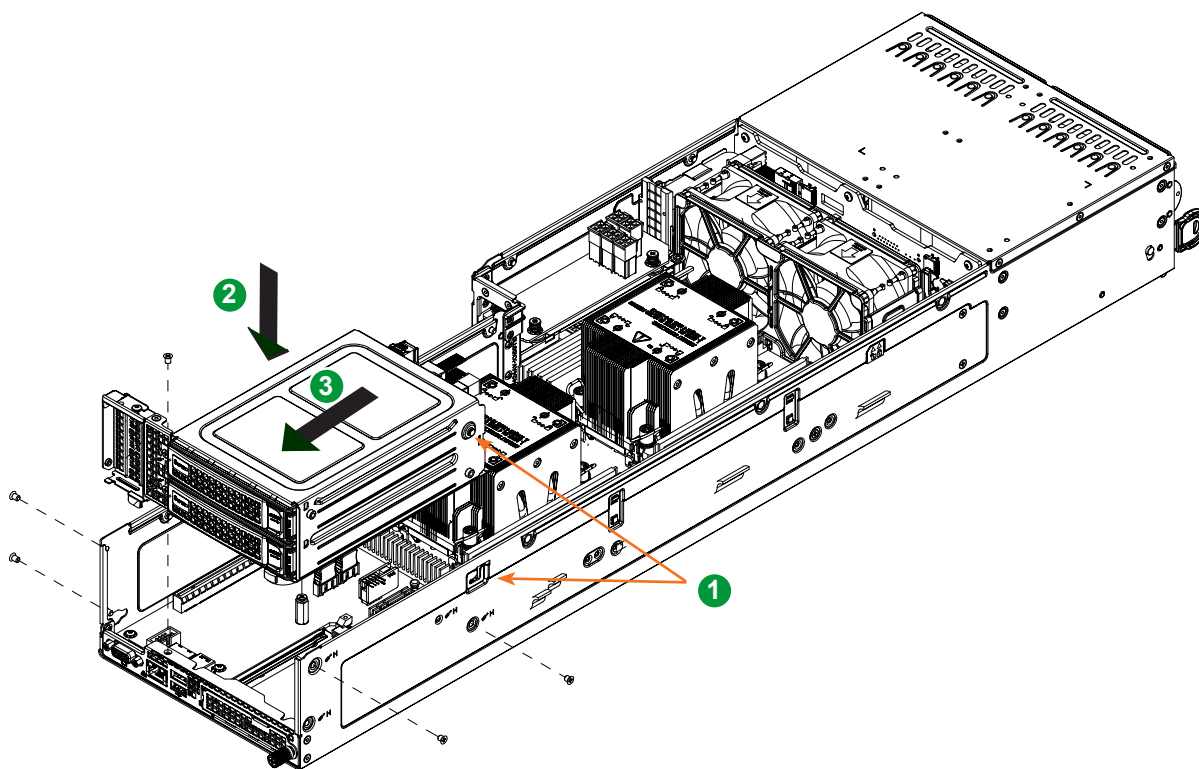

Figure 3-7. Installing Rear 3.5" Hard Drive Cage

Hot-Swap for NVMe Drives

Supersmicro servers support NVMe surprise hot-swap. For even better data security, NVMe *orderly* hot-swap is recommended. NVMe drives can be ejected and replaced remotely using BMC.

Ejecting a Drive

1. **BMC > Server Health > NVMe SSD**
2. Select Device, Group and Slot, and click **Eject**. After ejecting, the drive Status LED indicator turns green.
3. Remove the drive.

Note that *Device* and *Group* are categorized by the CPLD design architecture. *Slot* is the slot number on which the NVMe drives are mounted.

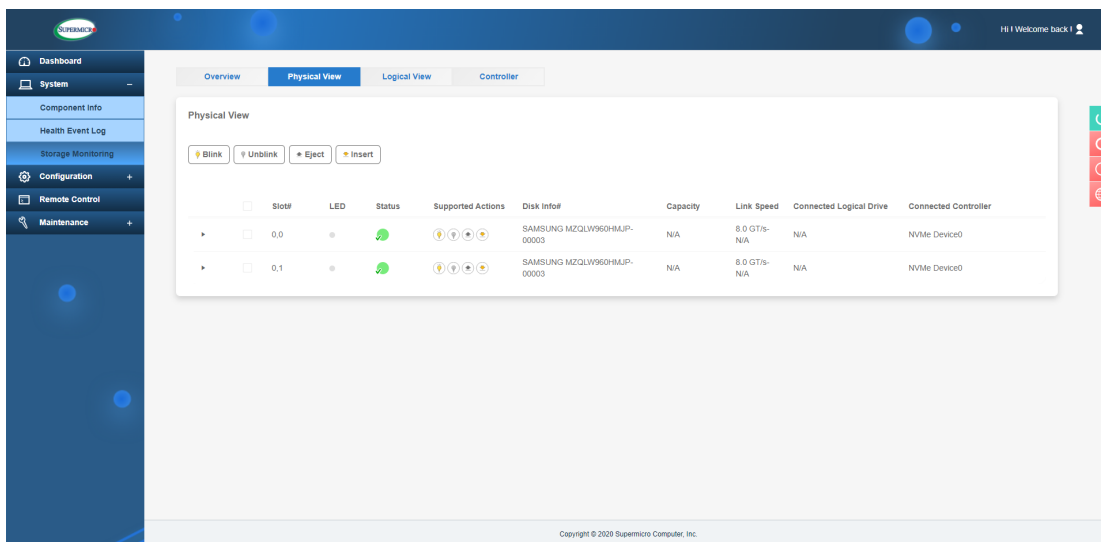

Figure 3-9. BMC Screenshot

Replacing the Drive

1. Insert the replacement drive.
2. **BMC > Server Health > NVMe SSD**
3. Select Device, Group and slot and click **Insert**. The drive Status LED indicator flashes red, then turns off. The Activity LED turns blue.

Checking the Temperature of an NVMe Drive

There are two ways to check using BMC.

Checking a Drive

- **BMC > Server Health > NVMe SSD** – Shows the temperatures of all NVMe drives, as in Figure 3-4.
- **BMC > Server Health > Sensor Reading > NVME_SSD** – Shows the single highest temperature among all the NVMe drives.

Installing M.2 Solid State Drives

The motherboard supports two M.2 SSDs with PCIe 3.0 x2 and SATA x1 in slots M.2-H1 and M.2-H2 (J17 and J18). Form factors 2280 and 22110 are supported.

Installing M.2 Drives

1. Remove power from the node, remove the node from the system, and remove the node cover.
2. Find the small plastic retaining clips in holes SRW1-4 and move them if necessary to fit your M.2 form factor. Open the clip.
3. Insert the M.2 sideways into the connector so that it lays flat, then secure it to the bracket with the plastic clip.
4. Replace the cover, node, and power.

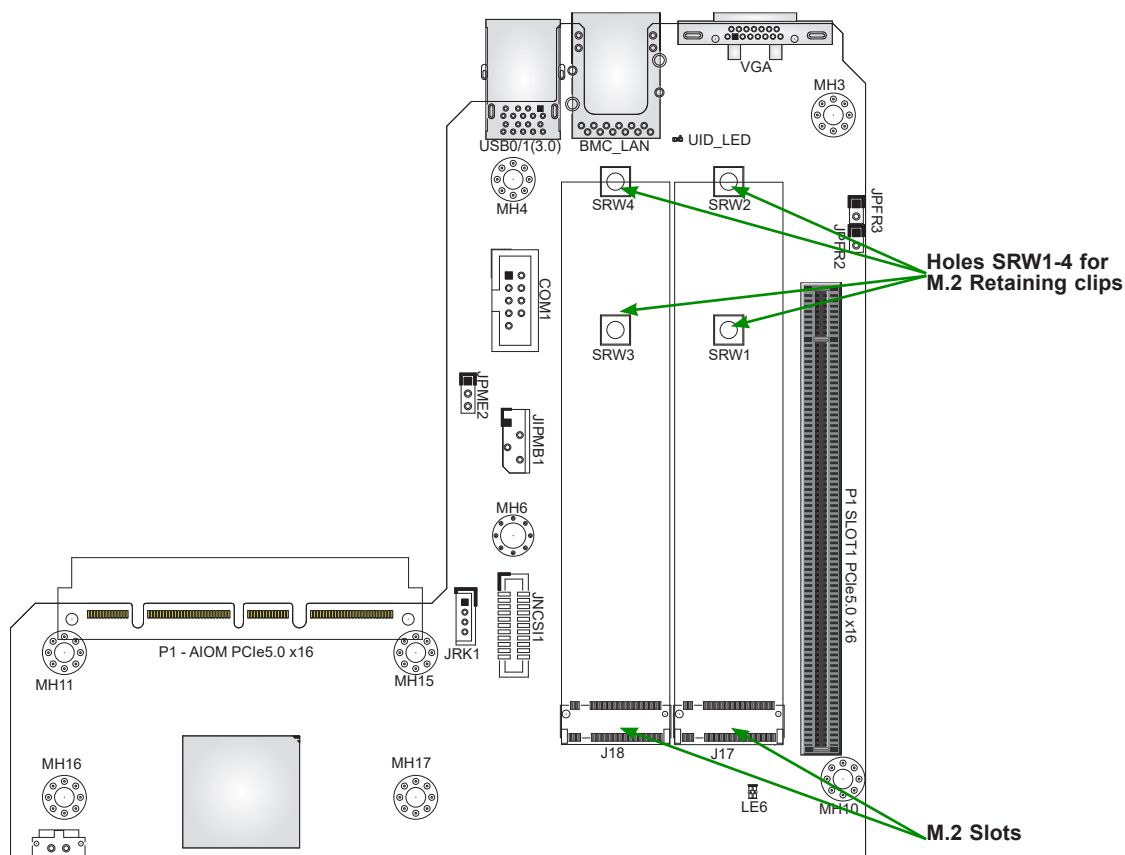

Figure 3-10. Installing an M.2 SSD

3.7 System Cooling

Fans

There are two 8-cm cooling fans per node for a total of eight in the system. These fans are not hot-plug and must be replaced when they fail.

Replacing the Node Fans

1. Power down the node, remove the node from the chassis and remove the cover from the node.
2. Disconnect the wiring to all fans.
3. Lift the fan tray up and out of the node.
4. Push upward on the underside of the failed fan to remove it from the fan tray.
5. Insert the replacement fan into the fan tray, making certain that the fan is facing in the same direction as the other fans in the fan tray.
6. Place the fan tray in the node.
7. Secure the fan tray to the floor of the node.
8. Reconnect the wiring to the fans.

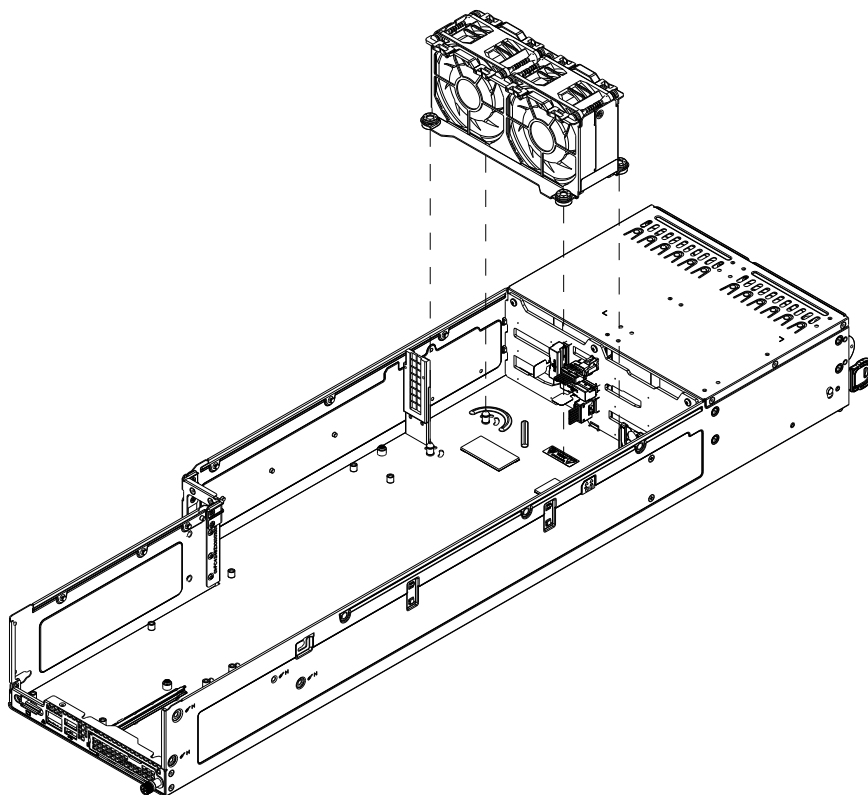

Figure 3-11. Removing the Fan Tray

Air Shrouds

Air shrouds concentrate airflow to maximize fan efficiency. The system requires air shrouds in each node.

Installing an Air Shroud

After all other components are installed:

1. Place the air shroud as illustrated below.
2. Slide it down into the tray just behind the fans.

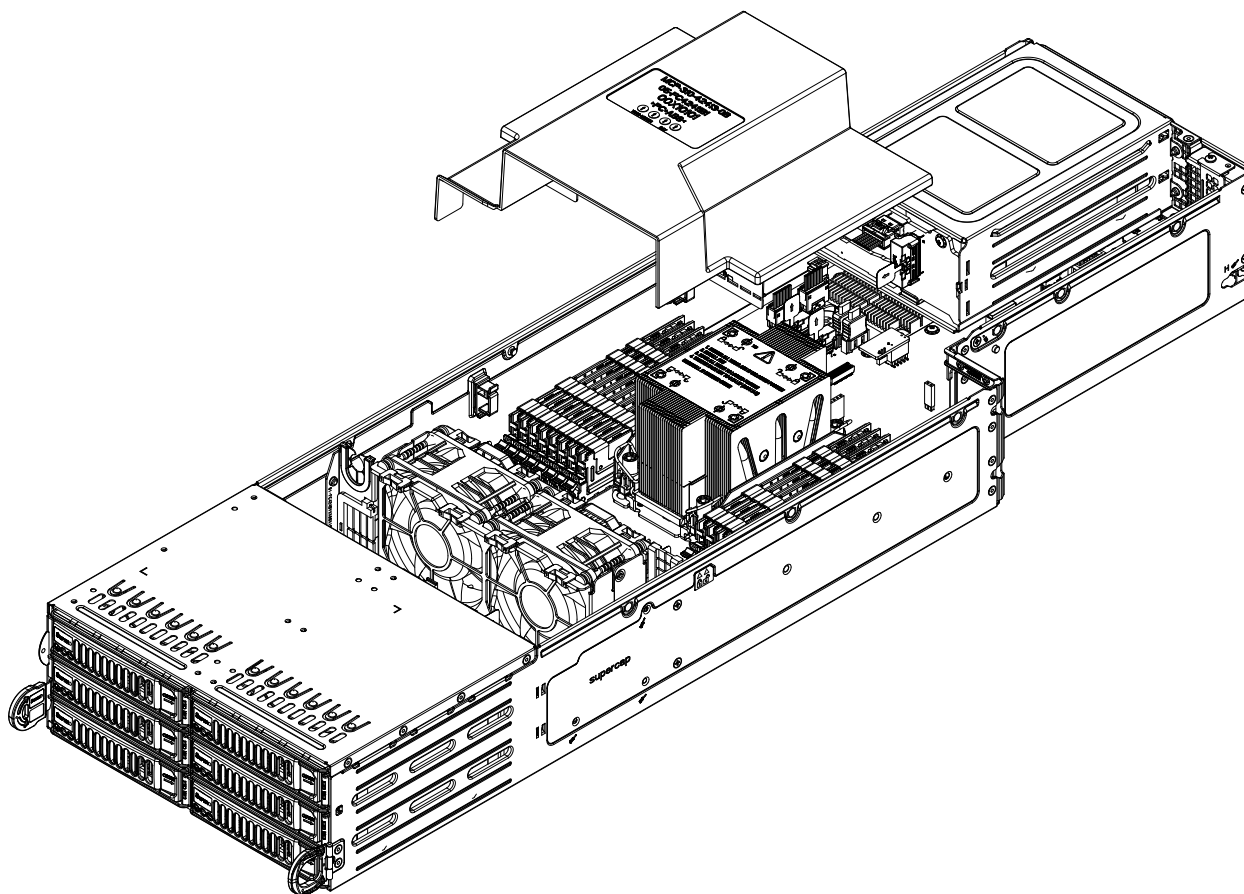

Figure 3-12. Installing the Air Shroud

3.9 Installing an AIOM Module

Each node has one rear mounted AIOM module, which adds various I/O ports to the node depending upon the module selected.

Installing an AIOM module

1. Remove the AIOM bracket by unscrewing two screws, one on the side of the node tray, one underneath.
2. Remove one screw securing the AIOM I/O shield.
3. Install any AIOM into the bracket, and secure the AIOM by tightening the two built-in screws on the AIOM.
4. Install the assembled AIOM bracket into the node tray, and tighten the two screws used in step 1.

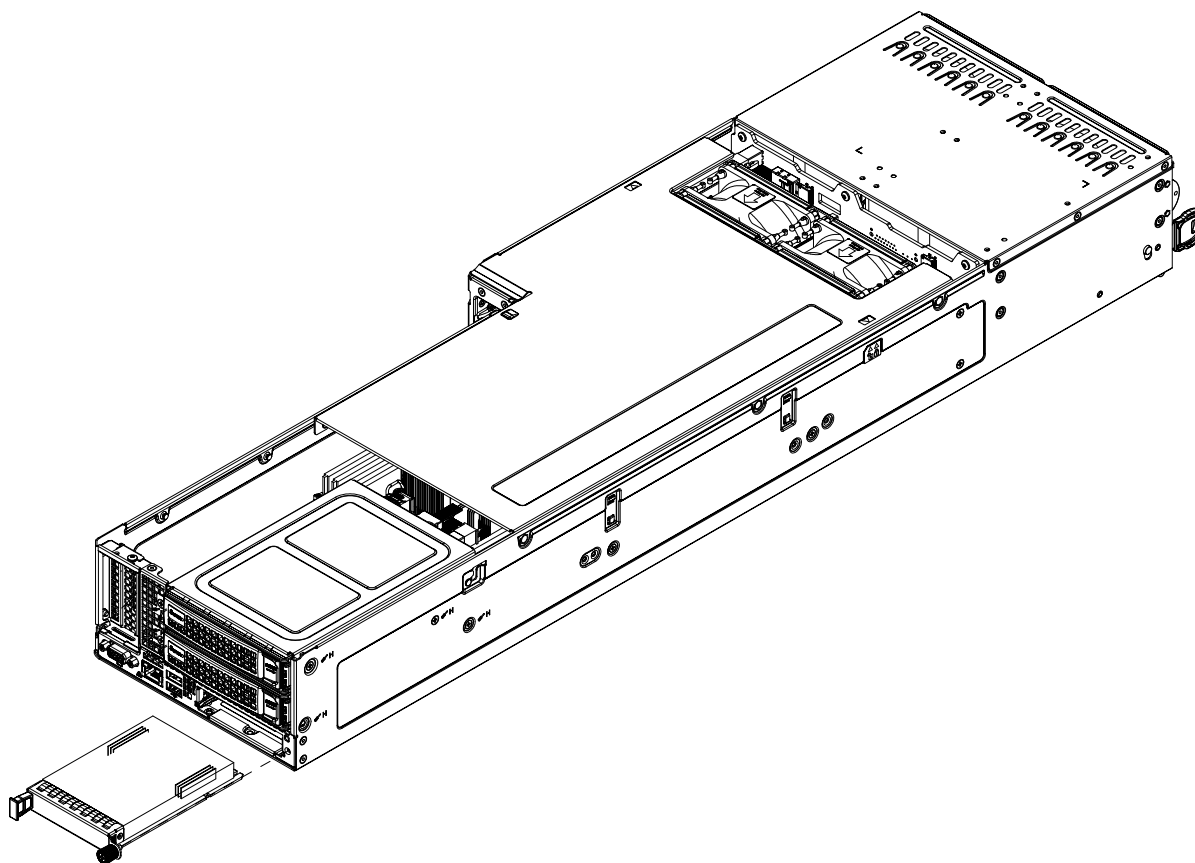

Figure 3-15. Installing the AIOM Module

3.10 Power Supply

The power supplies are redundant within their own side (left side or right side). The system will continue to operate if one module fails. It should be replaced as soon as convenient. The power supply modules are hot-swappable, meaning they can be changed without powering down the system. New units can be ordered directly from Supermicro or authorized distributors. These power supplies are auto-switching capable. This feature enables them to automatically sense the input voltage and operate at a 100-120v or 180-240v.

Power Supply LEDs

On the rear of the power supply module, an LED displays the status.

- **Solid Green:** When illuminated, indicates that the power supply is on.
- **Blinking Green:** When blinking, indicates that the power supply is plugged in and turned off by the system.
- **Blinking Amber:** When blinking, indicates that the power supply has a warning condition and continues to operate.
- **Solid Amber:** When illuminated, indicates that the power supply is plugged in, and is in an abnormal state. The system might need service. Please contact Supermicro technical support.

Replacing the Power Supply

1. Unplug the AC power cord from the failed power supply module.
2. On the back of the module, push the release tab sideways, as illustrated.
3. Grasp the handle of the power supply and pull it out of its bay.
4. Push the new power supply module into the power bay until it clicks into the locked position.
5. Plug the AC power cord back into the power supply module.

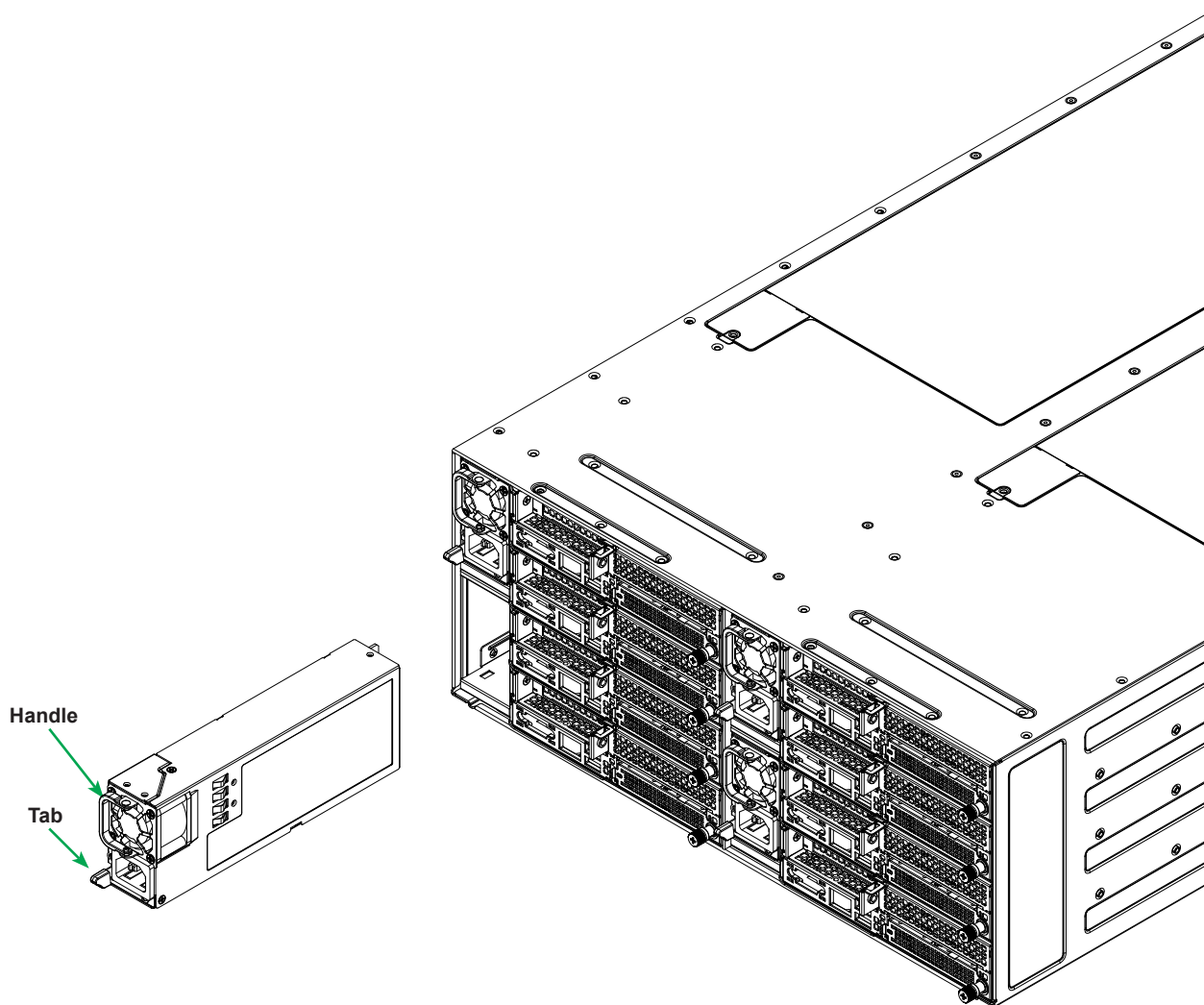

Figure 3-16. Installing a Power Supply Module

Power Supply Results

BMC Reset Options					
Test Item	PSU initial status	Node initial status	Smart Power button initial status	Action taken from initial state	Result from action
1	2 PSU installed and active	all nodes stressed at full power	smart power disabled	none	no power failure, no power capping, power consumption remains high (in this case 500+W)
2	2 PSU installed and active	all nodes stressed at full power	smart power disabled	smart power enabled	no power failure, no power capping, power consumption remains high (in this case 500+W)
3	2 PSU installed and active	all nodes stressed at full power	smart power enabled	none	no power failure, no power capping, power consumption remains high (in this case 500+W)
4	2 PSU installed and active	all nodes stressed at full power	smart power enabled	smart power disabled	no power failure, no power capping, power consumption remains high (in this case 500+W)
5	2 PSU installed and active	all nodes stressed at full power	smart power enabled	remove AC from one PSU	one PSU failed, set up power cap, power consumption falls
6	2 PSU installed and active	all nodes stressed at full power	smart power disabled	remove AC from one PSU	one PSU failed, CPU throttles, power cap not set
7	2 PSU installed and 1 PSU active	all nodes stressed at full power	smart power disabled, not power capped	install AC into 2nd PSU	smart power was disabled, power capping not enabled, so no change
8	2 PSU installed and 1 PSU active	all nodes stressed at full power	smart power enabled, power capped	install AC into 2nd PSU	remove power cap
9	2 PSU installed and 1 PSU active	all nodes stressed at full power	smart power disabled, not power capped	smart power enabled	set up power cap
10	2 PSU installed and 1 PSU active	all nodes stressed at full power	smart power enabled, power capped	smart power disabled	remove power cap, CPLD throttles CPUs
11	1 PSU installed	all nodes stressed at full power	smart power disabled, not power capped	install 2nd PSU, 2nd AC not installed	CPUs throttle. BMC will not set up power cap. CPU will de-throttle when the AC cord is installed
12	1 PSU installed	all nodes stressed at full power	smart power enabled, no power failure. not power capped	install 2nd PSU, 2nd AC not installed	although neither PSU failed, still enable power cap

BMC Reset Options					
Test Item	PSU initial status	Node initial status	Smart Power button initial status	Action taken from initial state	Result from action
13	2 PSU installed and active	all nodes stressed at full power	smart power disabled	remove one PSU	PSU removed. System will momentarily experience a power fail situation. CPLD will momentarily throttle CPU until PSU restored. Power capping will be not be enabled
14	2 PSU installed and active	all nodes stressed at full power	smart power enabled	remove one PSU	PSU removed. System will momentarily experience a power fail situation. Power cap enabled until restore state back to two PSU
15	x	x	smart power disabled	AC power cycle	smart power disabled
16	x	x	smart power enabled	AC power cycle	smart power enabled
17	x	x	x	removing master node	shifts the master node to the subsequent node.
18	x	x	x	installing a preceding node	makes the preceding node the master node
19	x	x	x	removing node	LCMC clears the power status and power consumption registers
20	x	x	x	installing a node	installed node can write into LCMC

3.11 Cable Routing Diagram

Refer to the diagram below for a representation of how the main cables are routed throughout the system. When disconnecting cables to add or replace components, refer to this diagram when adding or replacing components so you can reroute them in the same manner. Proper cable routing is important in maintaining adequate airflow through the system.

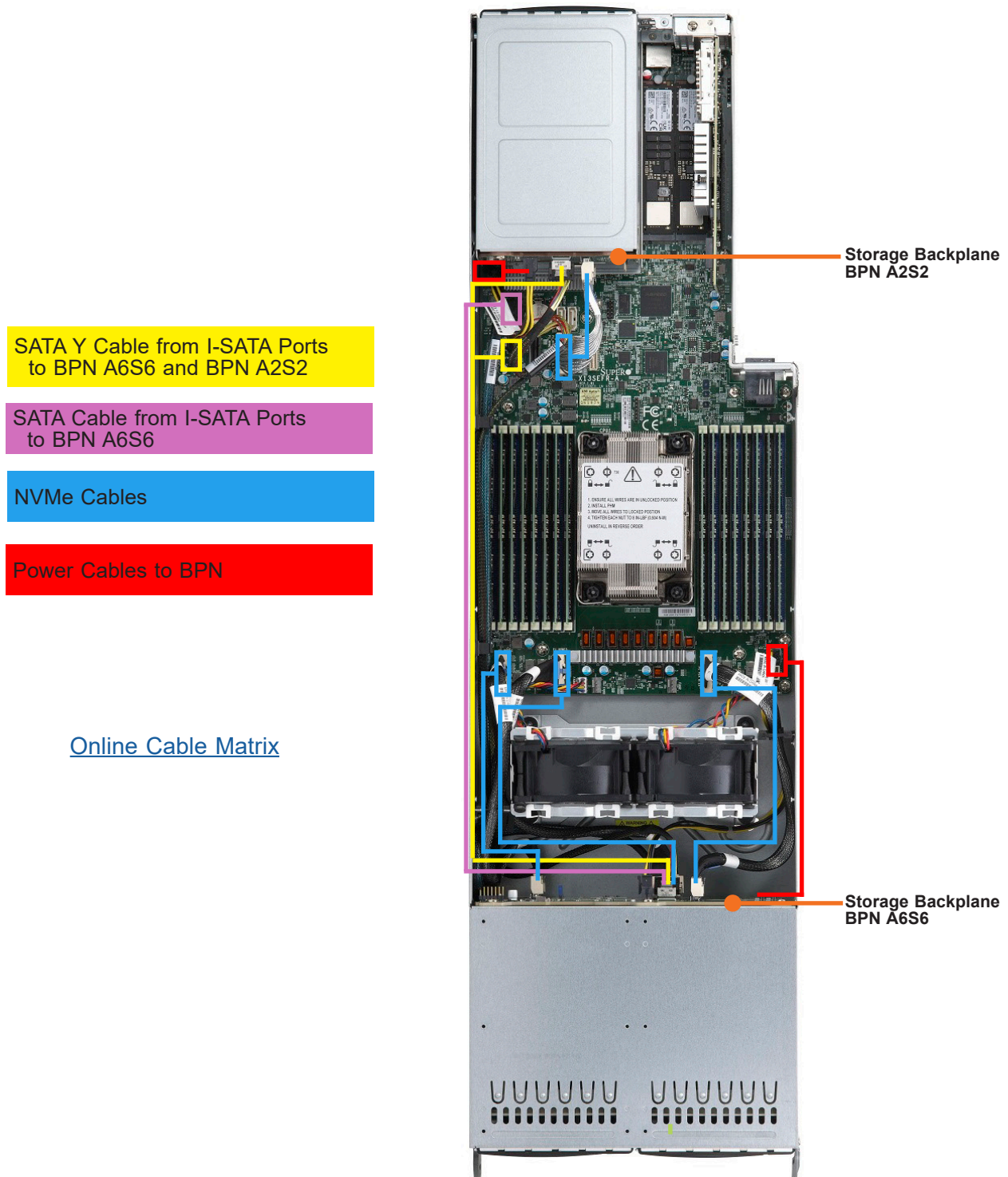

Figure 3-17. Cable Routing Diagram

Chapter 4

Motherboard Connections

This section describes the connections on the motherboard and provides pinout definitions. Note that depending on how the system is configured, not all connections are required. The LEDs on the motherboard are also described here. A motherboard layout indicating component locations may be found in [Chapter 1](#). More detail can be found in the [Motherboard Manual](#). Please review the Safety Precautions in [Appendix A](#) before installing or removing components.

4.1 Input/Output Ports

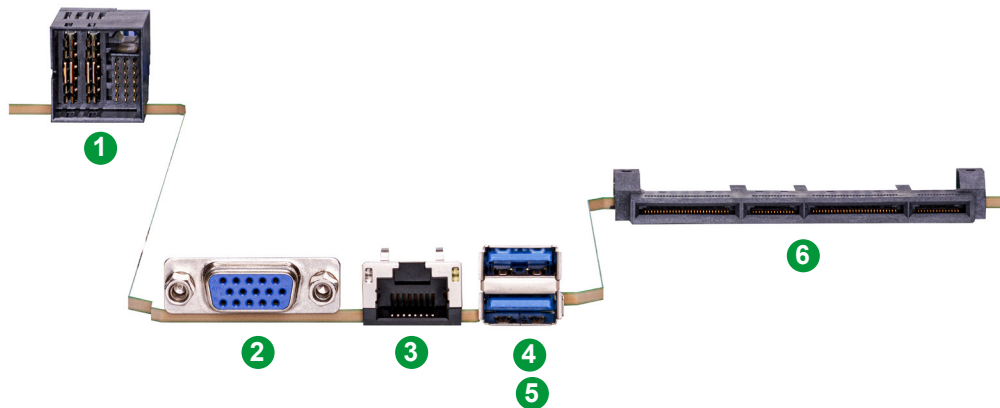

Figure 4-1. Rear I/O Ports

Rear I/O Ports			
#	Description	#	Description
1.	JPWR_MAX1	4.	USB0
2.	VGA	5.	USB1
3.	BMC LAN	6.	P1 - AIOM

LAN Ports

There is a dedicated LAN port for the BMC.

There can also be zero, two, or four network LAN ports on the chassis rear provided by the AIOM, depending on the option you purchased.

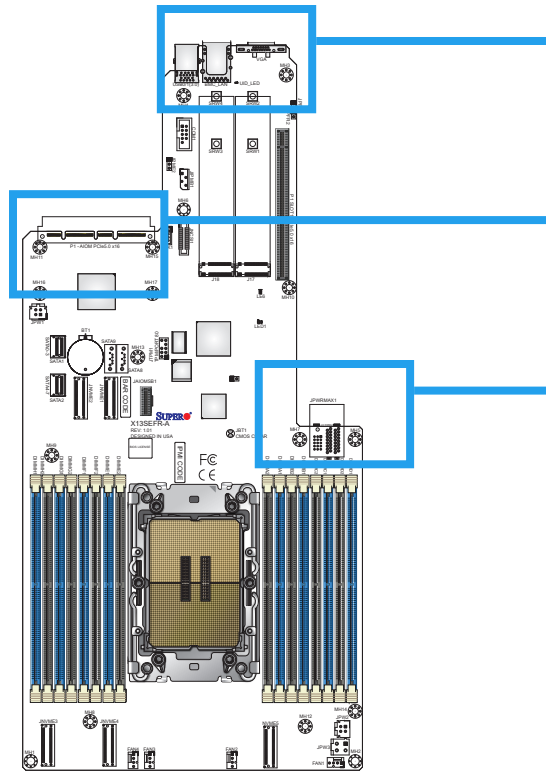

Figure 4-2. I/O Port Locations and Definitions

4.2 Power Connections

JPWRMAX1 is the power connector to the main power distribution board (PDB). JPW1 and JPW2 are the HDD backplane power headers. JPW3 is a HDD power header.

JPWRMAX1 Pin Definitions			
Pin#	Definition	Pin#	Definition
P1A	12V	P2A	GND
P1B	12V	P2B	GND
P1C	12V	P2C	GND
P1D	12V	P2D	GND
P1E	12V	P2E	GND
P1F	12V	P2F	GND
P1G	12V	P2G	GND
P1H	12V	P2H	GND
P1I	12V	P2I	GND
P1J	12V	P2J	GND
P1K	12V	P2K	GND
P1L	12V	P2L	GND
P1M	12V	P2M	GND
P1N	12V	P2N	GND
P1O	12V	P2O	GND
P1P	12V	P2P	GND

JPW1 / JPW2 Pin Definitions	
Pin#	Definition
1-2	GND
3-4	12V

JPW3 Pin Definitions	
Pin#	Definition
1	GND
2	GND
3	5V
4	12V

4.3 Headers and Connectors

Fan Headers

There are four fan headers on the motherboard, (FAN1-4). These are 4-pin fan headers, although pins 1-3 are backward compatible with traditional 3-pin fans. Four-pin fans allow fan speeds to be controlled by Thermal Management in the BMC. When using the Thermal Management setting, use all 3-pin fans or all 4-pin fans.

Fan Header Pin Definitions	
Pin#	Definition
1	Ground (Black)
2	+12V (Red)
3	Tachometer
4	PWM Control

TPM Header

The JTPM1 header is used to connect a Trusted Platform Module (TPM), which is available from Supermicro. A TPM connector is a security device that supports encryption and authentication in hard drives. It allows the motherboard to deny access if the TPM associated with the storage drive is not installed in the system. For more information on the TPM: <https://www.supermicro.com/manuals/other/TPM.pdf>.

Trusted Platform Module Header Pin Definitions			
Pin#	Definition	Pin#	Definition
1	P3V3	2	SPI_TPM_CS_N
3	PCIe_RESET_N#	4	SPI_PCH_MISO
5	SPI_PCH_CLK#	6	Ground
7	SPI_PCH_MOSI	8	N/A
9	JTPM1_P3V3A	10	IRQ_TPM_SPIN_N

COM Header

The motherboard has one COM header (COM1) that provides a serial connection .

COM Header (COM1) Pin Definitions			
Pin#	Definition	Pin#	Definition
1	DCD	2	DSR
3	RXD	4	RTS
5	TXD	6	CTS
7	DTR	8	RI
9	Ground	10	N/A

External BMC I²C Header

A 4-pin System Management Bus header for the BMC is located at JIPMB1. Connect a cable to this header to use the IPMB I²C connection on your system. .

External I ² C Header Pin Definitions	
Pin#	Definition
1	Data
2	Ground
3	Clock
4	No Connection

NVMe Connectors

JNVME1 – JNVME5 are Non-volatile Memory Express (NVMe) connectors that provide two connections for devices like solid state drives.

SATA 3.0 Ports

The motherboard has four SATA 3.0 ports (SATA1, SATA2, SATA8, and SATA9).

M.2 Slots

The motherboard has two M.2 slots, M.2-H1 and M.2-H2 (J17, J18). They support PCIe 3.0 x2 or SATA x1 from PCH, and support the 22110 and 2280 form factors.

4.4 Jumpers

Explanation of Jumpers

To modify the operation of the motherboard, jumpers are used to choose between optional settings. Jumpers create shorts between two pins to change the function associated with it. Pin 1 is identified with a square solder pad on the printed circuit board. See the motherboard layout page for jumper locations.

Note: On a two-pin jumper, "Closed" means the jumper is on both pins and "Open" indicates the jumper is either on only one pin or has been completely removed.

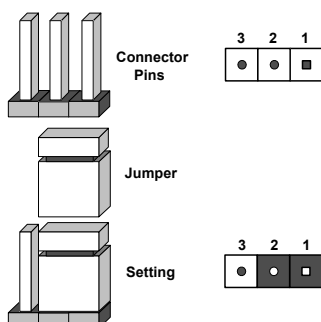

CMOS Clear

Use the jumper, JBT1, to clear the CMOS as described in [Section 7.7](#).

ME Manufacturing Mode

Close pins 2-3 of jumper JPME2 to bypass SPI flash security and force the system to operate in the manufacturing mode, which will allow you to flash the system firmware from a host server for system setting modifications.

ME Manufacturing Mode Jumper Settings	
Jumper Setting	Definition
Pins 1-2	Normal (Default)
Pins 2-3	Manufacturing Mode

4.5 LED Indicators

Network LAN LEDs

The Ethernet ports each have two LEDs. One LED indicates activity when flashing green. The other may be green, amber or off to indicate the speed of the connection. [Speeds](#) are noted in Chapter 1.

BMC Dedicated LAN LEDs

A dedicated BMC LAN port is also included on the motherboard. The amber LED on the right of the BMC LAN port indicates activity, while the LED color on the left indicates the speed of the connection.

BMC Link LED	
Color	Definition
Off	No Connection
Green	100 Mb/s
Amber	1 Gb/s

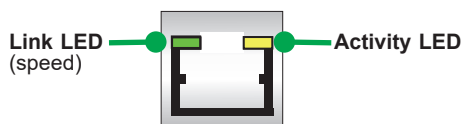

Unit ID LED

A rear unit identifier (UID) indicator at UID_LED is located on the motherboard near the BMC LAN port. When the UID indicator is activated, it is visible from the chassis rear but not obvious.

Onboard Power LED

The Onboard Power LED is LE6. When this LED is on, the system power is on.

BMC Heartbeat LED

LED1 is the BMC heartbeat LED. When the LED is blinking green, BMC is functioning normally.

Chapter 5

Software

After the hardware has been installed, you can install the Operating System (OS), configure RAID settings and install the drivers.

5.1 Microsoft Windows OS Installation

If you will be using RAID, you must configure RAID settings before installing the Windows OS and the RAID driver. Refer to the RAID Configuration User Guides posted on our website at www.supermicro.com/support/manuals.

Installing the OS

1. Create a method to access the MS Windows installation ISO file. That can be a USB flash or media drive.
2. Retrieve the proper RST/RSTe driver. Go to the Supermicro web page for your motherboard and click on "Download the Latest Drivers and Utilities", select the proper driver, and copy it to a USB flash drive.
3. Boot from a bootable device with Windows OS installation. You can see a bootable device list by pressing **F11** during the system startup.

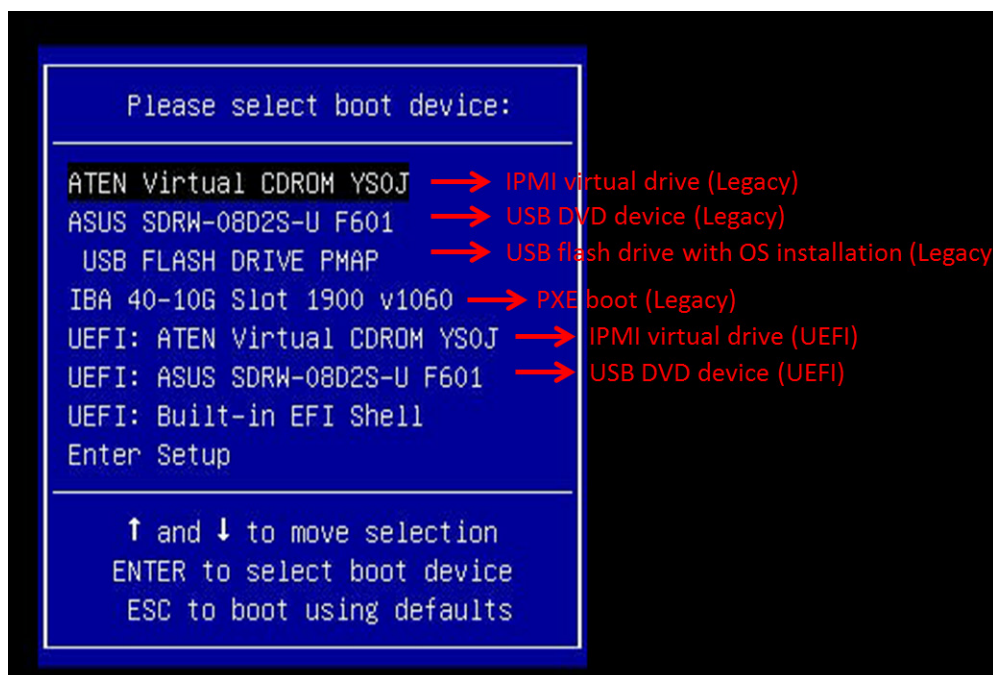

Figure 5-1. Select Boot Device

4. During Windows Setup, continue to the dialog where you select the drives on which to install Windows. If the disk you want to use is not listed, click on “Load driver” link at the bottom left corner.

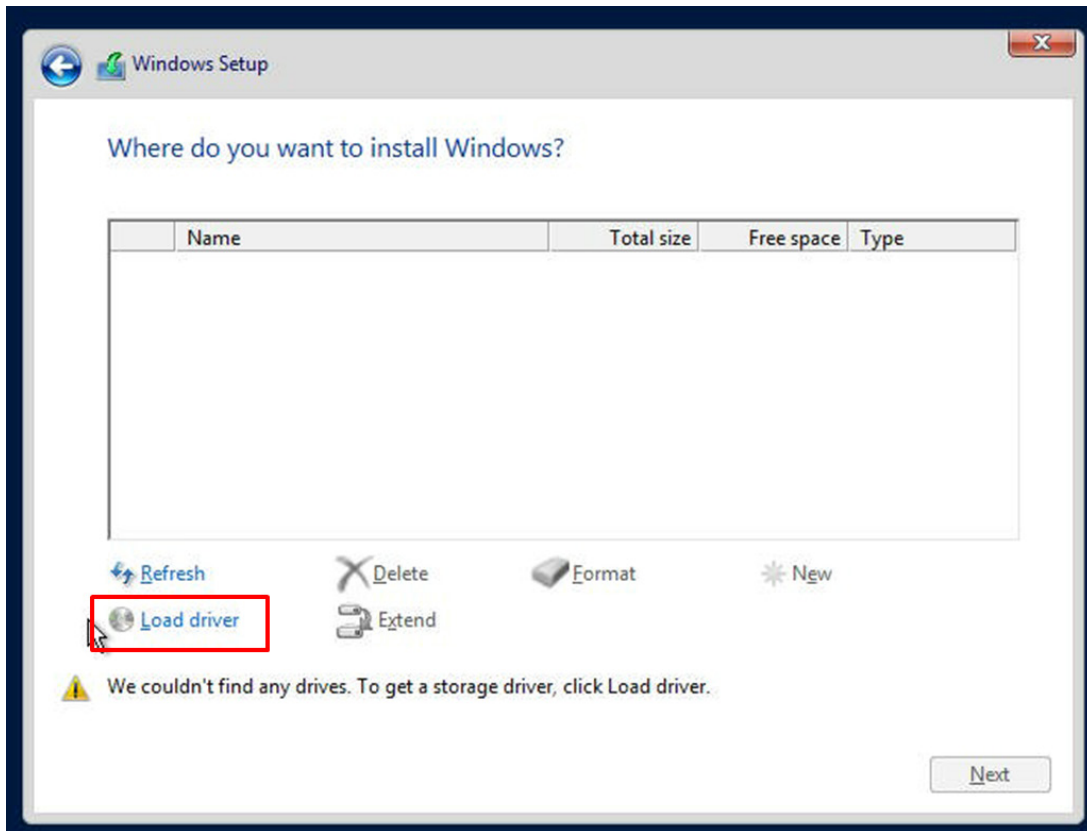

Figure 5-2. Load Driver Link

To load the driver, browse the USB flash drive for the proper driver files.

- For RAID, choose the SATA/sSATA RAID driver indicated then choose the storage drive on which you want to install it.
 - For non-RAID, choose the SATA/sSATA AHCI driver indicated then choose the storage drive on which you want to install it.
5. Once all devices are specified, continue with the installation.
 6. After the Windows OS installation has completed, the system will automatically reboot multiple times.

5.2 Driver Installation

The Supermicro website contains drivers and utilities for your system at <https://www.supermicro.com/wdl/driver>. Some of these must be installed, such as the chipset driver.

After accessing the website, go into the CDR_Images (in the parent directory of the above link) and locate the ISO file for your motherboard. Download this file to to a USB flash or media drive. (You may also use a utility to extract the ISO file if preferred.)

Another option is the X13SEFR-A [product web page](#), and "Download the Latest Drivers and Utilities".

Insert the flash drive or disk and the screenshot shown below should appear.

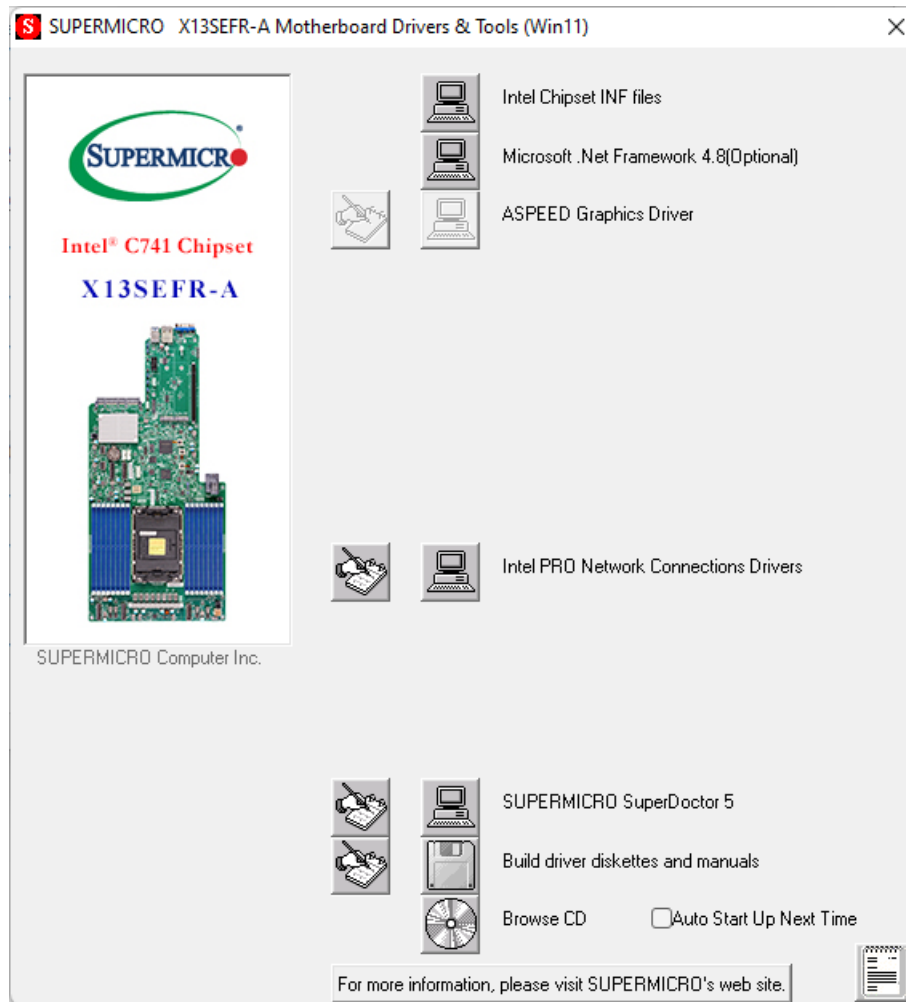

Figure 5-3. Driver & Tool Installation Screen

Note: Click the icons showing a hand writing on paper to view the readme files for each item. Click the computer icons to the right of these items to install each item (from top to the bottom) one at a time. **After installing each item, you must re-boot the system before moving on to the next item on the list.** The bottom icon with a CD on it allows you to view the entire contents.

5.3 SuperDoctor® 5

The Supermicro SuperDoctor 5 is a program that functions in a command-line or web-based interface for Windows and Linux operating systems. The program monitors such system health information as CPU temperature, system voltages, system power consumption, fan speed, and provides alerts via email or Simple Network Management Protocol (SNMP).

SuperDoctor 5 comes in local and remote management versions and can be used with Nagios to maximize your system monitoring needs. With SuperDoctor 5 Management Server (SSM Server), you can remotely control power on/off and reset chassis intrusion for multiple systems with SuperDoctor 5 or the BMC. SuperDoctor 5 Management Server monitors HTTP, FTP, and SMTP services to optimize the efficiency of your operation.

[SuperDoctor® Manual and Resources](#)

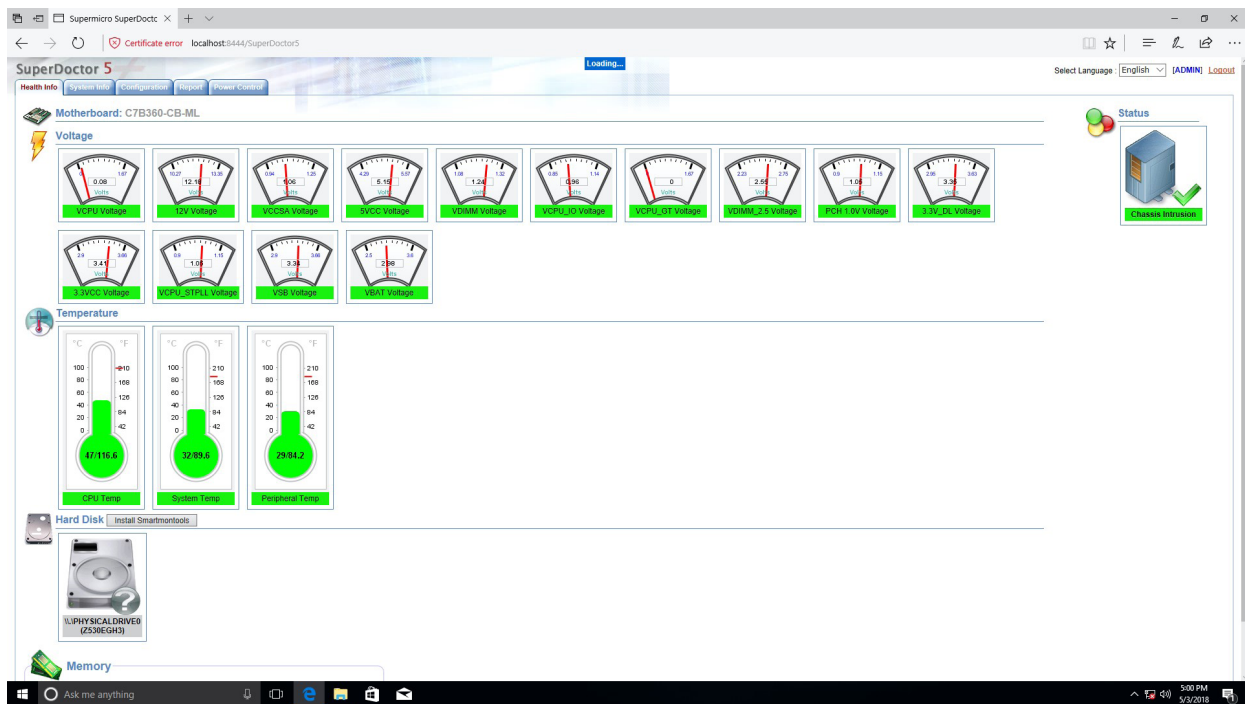

Figure 5-4. SuperDoctor 5 Interface Display Screen (Health Information)

5.4 BMC

The motherboard provides remote access, monitoring and management through the baseboard management controller (BMC) and other management controllers distributed among different system modules. There are several BIOS settings that are related to BMC. For general documentation and information on BMC, visit our website at:

www.supermicro.com/en/solutions/management-software/bmc-resources

BMC ADMIN User Password

For security, each system is assigned a unique default BMC password for the ADMIN user. This can be found on a sticker on the chassis and a sticker on the motherboard. The sticker also displays the BMC MAC address. If necessary, the password can be reset using the Supermicro IPMICFG tool.



Figure 5-5. BMC Password Label

The sticker can be found on the pull-out service tag at the front of the chassis. See Chapter 1 for the [location](#).

Chapter 6

Optional Components

This chapter describes alternate configurations and optional system components.

6.1 Storage Protocols Supported

The storage drive bays can support SATA, SAS, and NVMe in any combination. To enable SAS and NVMe, additional hardware is required. Once the supporting hardware is installed for a selection of bays, drives of any storage protocol type can be inserted.

SATA – The default configuration supports up to twelve SATA drives.

SAS – An add-on controller card and cables can support up to twelve SAS drives.

NVMe – The motherboard supports up to ten NVMe drives. The Ultra Riser card supports two more. Additional cables are required.

6.2 TPM Security Module

SPI capable TPM 2.0 (or 1.2) with Infineon 9670 controller, vertical form factor

The JTPM1 header is used to connect a Trusted Platform Module (TPM). A TPM is a security device that supports encryption and authentication in hard drives. It enables the motherboard to deny access if the TPM associated with the hard drive is not installed in the system.

Details and installation procedures are at:

<http://www.supermicro.com/manuals/other/TPM.pdf>.

- AOM-TPM-9670V
- AOM-TPM-9671V

6.3 Intel Virtual RAID on CPU (VROC)

Intel® Virtual RAID on CPU (Intel VROC) is an enterprise RAID solution for NVMe SSDs directly attached to Intel Xeon Scalable processors. Intel Volume Management Device (VMD) is an integrated controller inside the CPU PCIe root complex.

- A single processor supports up to 12 NVMe SSDs and up to 6 RAID arrays.
- A dual processor system supports up to 24 NVMe SSDs and 12 RAID arrays.

Stripe sizes are 4K, 8K, 16K, 32K, 64K, 128K.

Requirements and Restrictions

- **Intel VROC is only available when the system is configured for UEFI boot mode.**
- To enable the **mdadm** command and support for RSTe, install the patch from
 - Linux: <https://downloadcenter.intel.com/download/28158/Intel-Virtual-RAID-on-CPU-Intel-VROC-and-Intel-Rapid-Storage-Technology-enterprise-Intel-RSTe-Driver-for-Linux->
 - Windows: <https://downloadcenter.intel.com/download/28108/Intel-Virtual-RAID-on-CPU-Intel-VROC-and-Intel-Rapid-Storage-Technology-enterprise-Intel-RSTe-Driver-for-Windows->
- To enable Intel VROC, a hardware key must be inserted on the motherboard, and the appropriate processor's Virtual Management Devices must be enabled in the BIOS setup.
- It is possible to enable Intel VROC without a hardware key installed, but only RAID0 will be enabled.
- Intel VROC is not compatible with secure boot. This feature must be disabled.
- When creating bootable OS RAID1 devices, you must have both devices on the same CPU, and a VMD on that CPU.
- Spanning drives when creating RAID devices is not recommended due to performance issues, even though it is supported.

Supported SSDs and Operating Systems

To see the latest support information: <https://www.intel.com/content/www/us/en/support/articles/000030310/memory-and-storage/ssd-software.html>

Additional Information

Additional information is available on the product page for the Supermicro add-on card and the linked manuals.

www.supermicro.com/products/accessories/addon/AOC-VROCxxxMOD.cfm

Hardware Key

The Intel VROC hardware key is a license key that detects the Intel VROC SKU and activates the function accordingly. The key must be plugged into the Supermicro motherboard (connector JRK1). The key options are:

Intel® VROC Keys			
VROC Package	Description	Part Number	Intel MM Number
Standard	RAID 0, 1, 10 Supports 3rd party SSDs	AOC-VROCSTNMOD	951605
Premium	RAID 0, 1, 5, 10 Supports 3rd party SSDs	AOC-VROCPREMOD	951606
Intel SSD only	RAID 0, 1, 5, 10 Supports Intel SSDs only	AOC-VROCINTMOD	956822

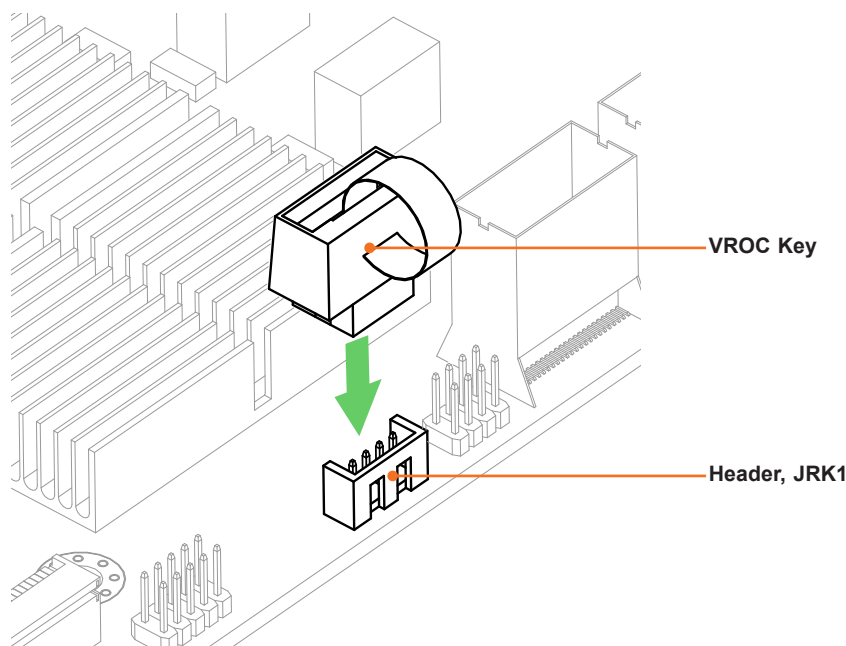

Figure 7-1. Intel VROC RAID Key and Motherboard Connector JRK1

Configuring Intel VMD

VMD must be enabled on PCIe ports which have NVMe drives attached to them in order for those drives to be added to a VROC RAID configuration. The default BIOS setting for the NVMe Mode Switch is **Auto** which automatically enables VMD on all installed NVMe drives.

NVMe Mode Switch :

- **Auto** Enables VMD for all NVMe ports if VROC Key is installed.
- **VMD** Enables VMD for all NVMe ports despite the lack of the VROC Key.
- **Manual** Allows the user to select specific NVMe ports on which to enable VMD.

The NVMe Mode Switch can be viewed or selected at **BIOS > Advanced > Chipset Configuration > North Bridge > IIO Configuration > Intel® VMD Technology**.

Note: Without a VROC Key, there is no RAID support with the **Auto** switch. Only RAID 0 is supported with the **VMD** and **Manual** switches.

Configuring VMD Manually

The steps for manually configuring VMD on specific NVMe ports in UEFI BIOS are shown below. This example shows different but similar system with 12 NVMe. Yours will look different.

1. Reboot the server and press [DEL] key to access the BIOS options.
2. Switch to **Advanced > Chipset Configuration > North Bridge > IIO Configuration > Intel® VMD Technology**.
3. Select **VMD Mode Switch**, then select **Manual**.

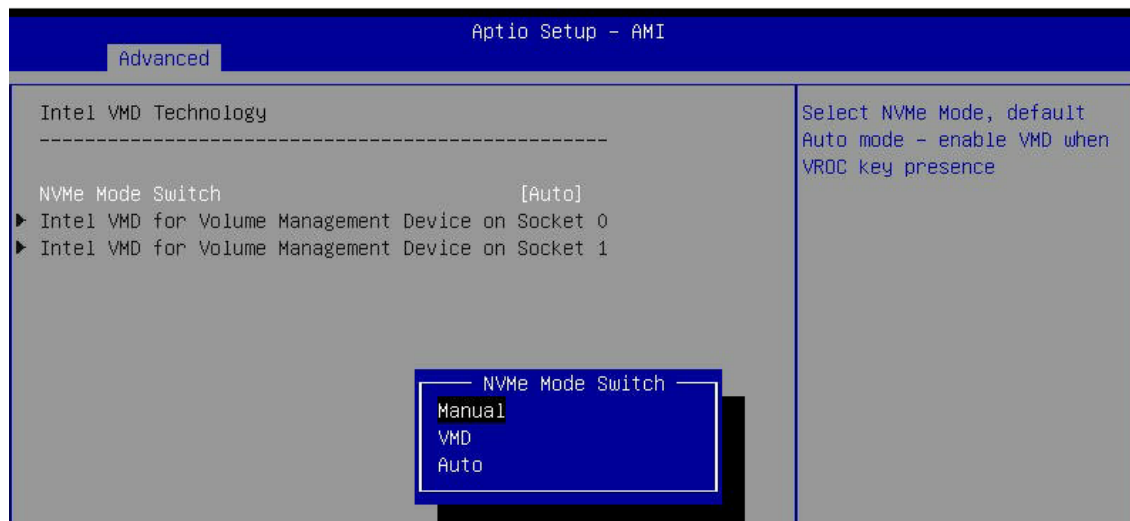

Note that Socket 0 contains CPU1; Socket 1 contains CPU2

Figure 6-7. BIOS, Selecting VMD Mode

Caution: VMD must only be enabled on NVMe port resources. If VMD is enabled on other PCIe ports, the functionality of those ports will be impacted. See the table below.

4. Select “Intel VMD for Volume Management Device on” on Socket 0 (CPU1) or Socket 2 (CPU2) to enable VMD for devices under the respective CPU.

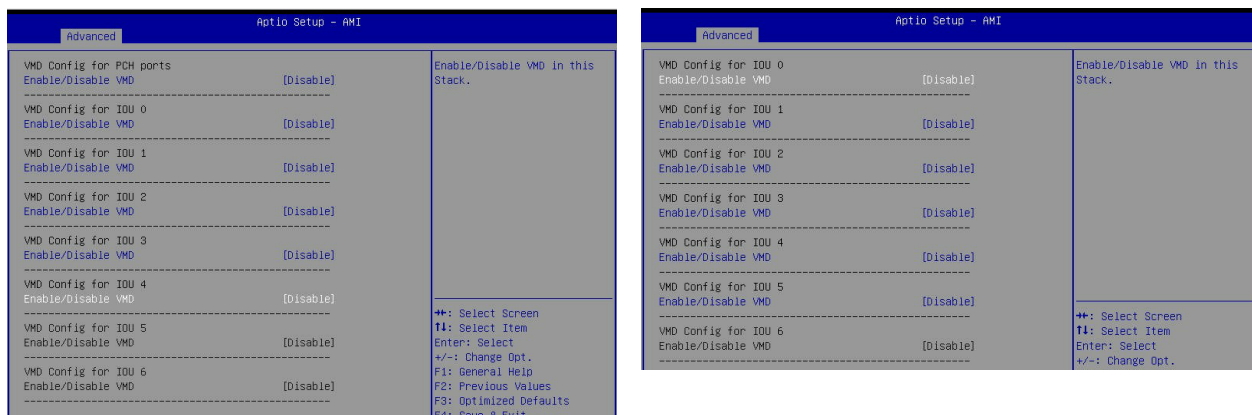

Figure 6-8. Intel VMD for Volume Management Device on Socket 0 and Socket 1

5. Choose Enable for “Enable/Disable VMD” for IOU 3 to list the available devices under IOU 3.

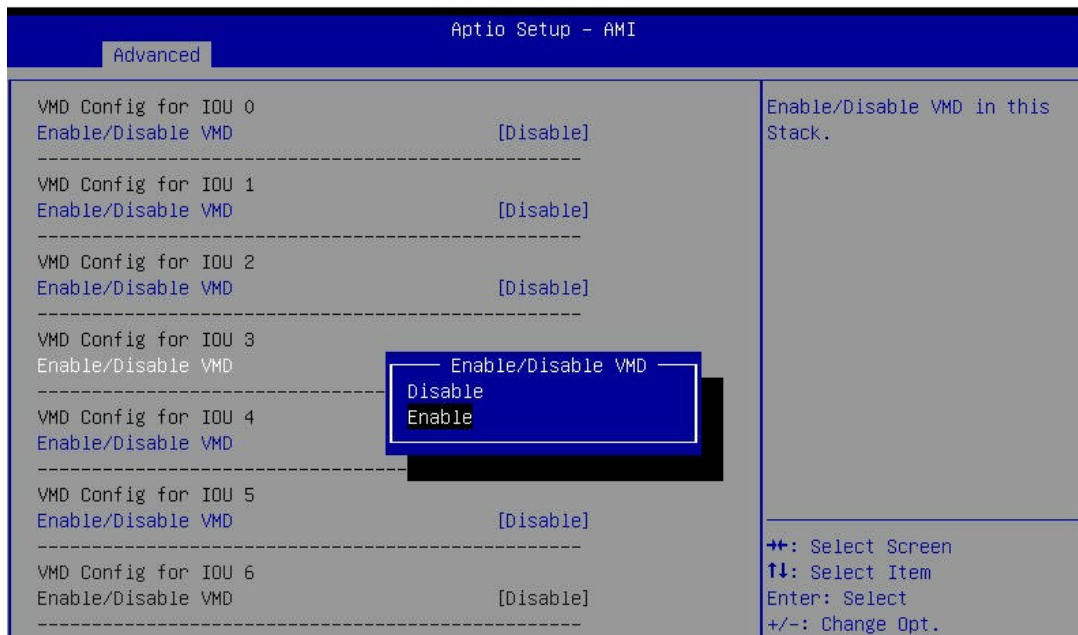

Figure 6-9. BIOS, Enabling VMD on Socket 1 (CPU2) (Example)

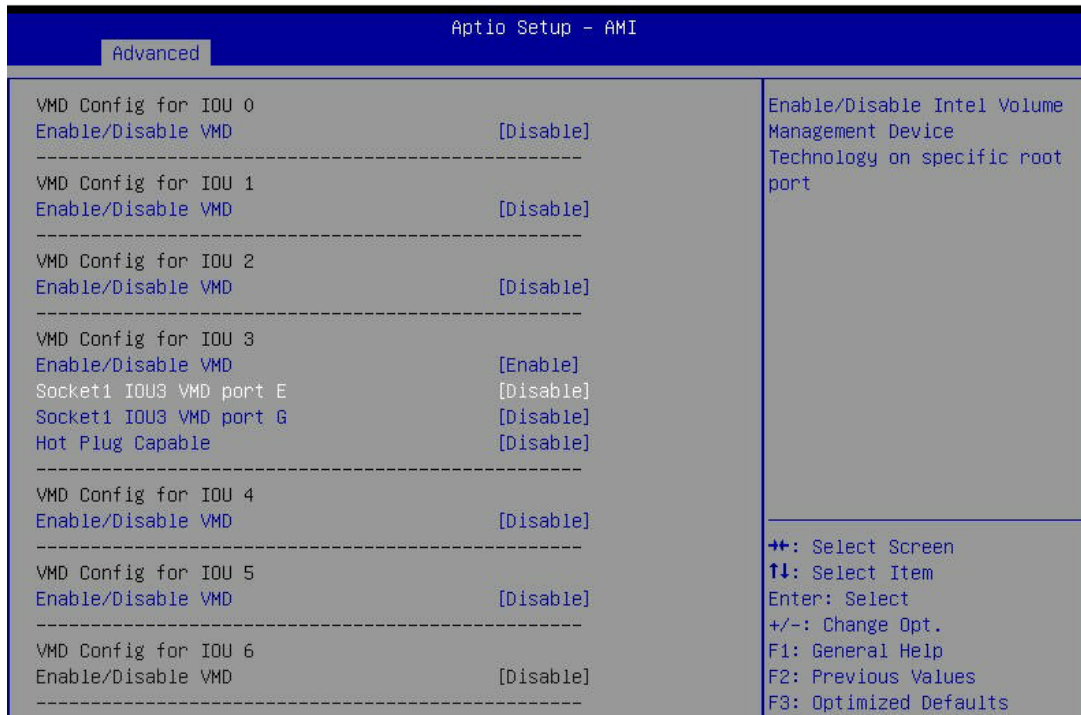

Figure 6-10. BIOS, Enabling VMD on Socket 1 (Example)

6. Enable the NVMe port resource according to table above for the NVMe drives that will be used in a RAID configuration.

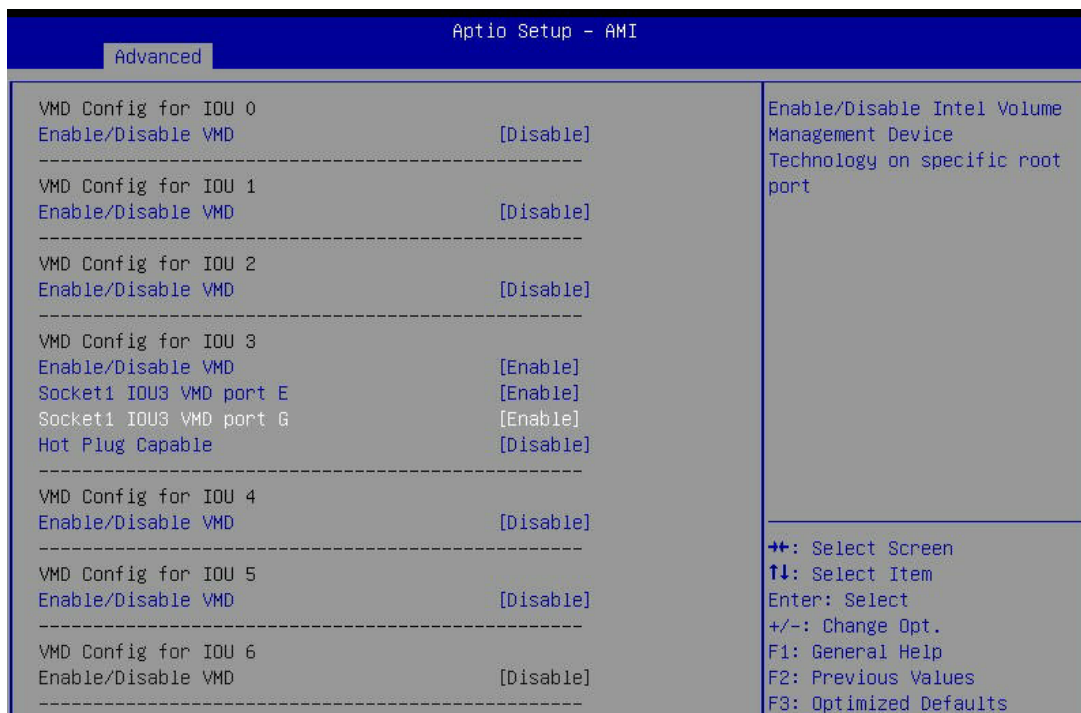

Figure 6-11. BIOS, Enabling Socket 1 (Example)

7. Choose whether to make the NVMe drives in this IOU **Hot Plug Capable** by selecting Enabled or Disabled.
8. Repeat steps 4 through 7 for each IOU # on each CPU to enable VMD on the desired NVMe ports.

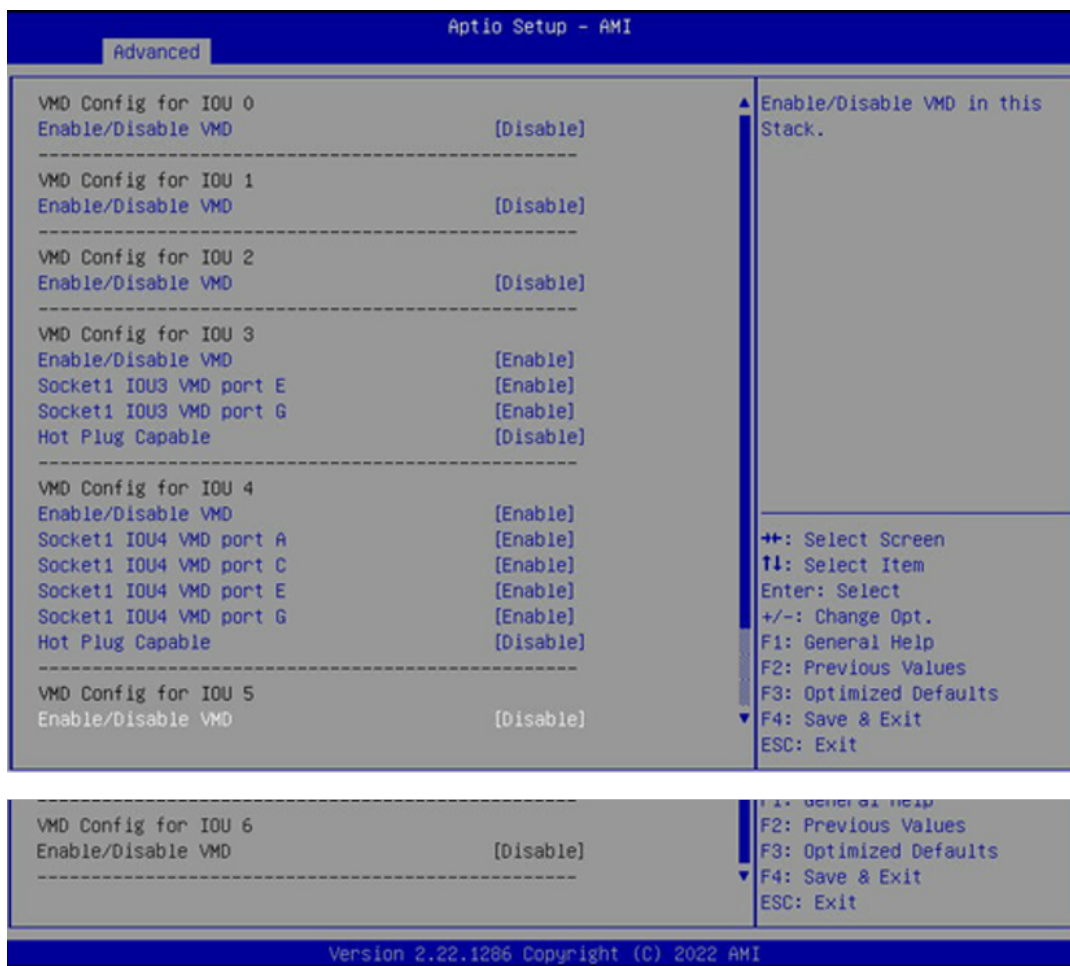

Figure 6-12. BIOS, Enabling Socket 1 Completed (Example)

9. Press [F4] to save the configuration and reboot the system.

Note: If there is an existing RAID configuration, delete the RAID volume associated with the VMD controller before disabling the controller. Failure to do so may lead to unexpected behavior.

Note: The effects of physically changing or swapping a CPU on the VMD controller have not been thoroughly tested or documented.

Creating NVMe RAID Configurations

1. Open **Advanced > Intel(R) Virtual RAID on CPU > All Intel VMD Controllers > Create RAID Volume**.

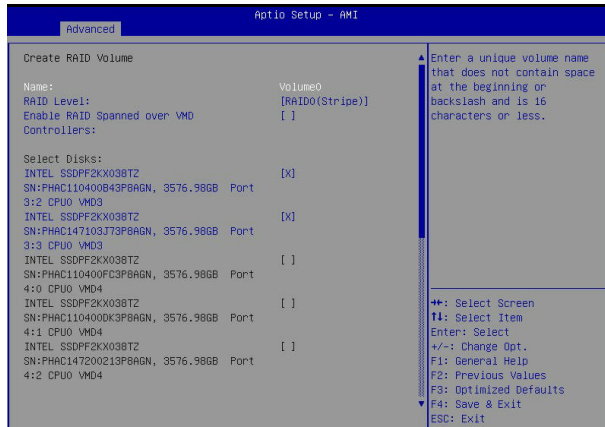

Figure 6-13. Created Volume *without* enabling RAID spanned over VMD controller

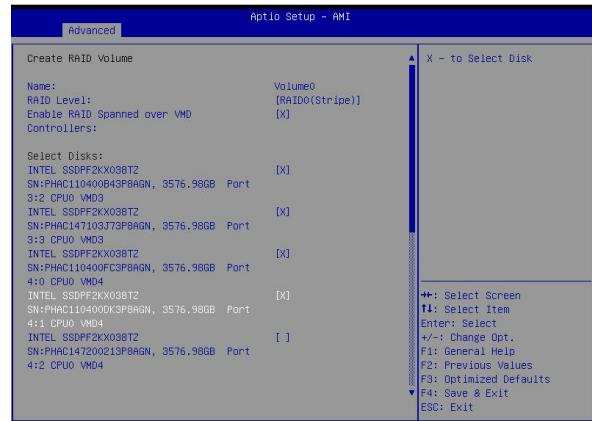

Figure 6-14. Created Volume *with* enabling RAID spanned over VMD controller

2. Set **Name**.
3. Set **RAID Level**.
4. If cross-controller RAID is required, select **Enable RAID spanned over VMD Controller**.
5. Select specific disks for RAID with an [X].
 - RAID0: Select at least two [2 - 24] disks
 - RAID1: Select only two disks
 - RAID5: Select at least three [3 - 24] disks
 - RAID10: Select only four disks
6. Select **Strip Size** (Default 64KB).
7. Select **Create Volume**.
8. If another RAID is needed, start again at step 1.

Status Indications

An LED indicator on the drive carrier shows the RAID status of the drive.

Drive Carrier Status LED Indicator	
Status	State (red)
Normal function	OFF
Locating	4 Hz blink
Fault	Solid ON
Rebuilding	1 Hz Blink

IBPI SFF 8489 Defined Status LED States

Hot-Swap Drives

Intel VMD enables hot-plug and hot-unplug for NVMe SSDs, whether from Intel or other manufacturers. Under vSphere ESXi, several steps are necessary to avoid potential stability issues. See the information at the link [1] below.

Hot-unplug

1. Prevent devices from being re-detected during rescan:

```
esxcli storage core claiming autoclaim --enabled=false
```

2. Unmount the VMFS volumes on the device. Check [2] for details.
3. Detach the device. Check [3] for details.
4. Physically remove the device.

Hot-plug

- Physically install the device.

ESXi will automatically discover NVMe SSDs, but a manual scan may be required in some cases.

Related Information Links

[1] <https://kb.vmware.com/s/article/2151404>

[2] <https://docs.vmware.com/en/VMware-vSphere/6.5/com.vmware.vsphere.storage.doc/GUID-1B56EF97-F60E-4F21-82A7-8F2A7294604D.html>

[3] <https://docs.vmware.com/en/VMware-vSphere/6.5/com.vmware.vsphere.storage.doc/GUID-F2E75F67-740B-4406-9F0C-A2D99A698F2A.html>

Chapter 7

Troubleshooting and Support

7.1 Information Resources

Website

A great deal of information is available on the Supermicro website, [supermicro.com](https://www.supermicro.com).

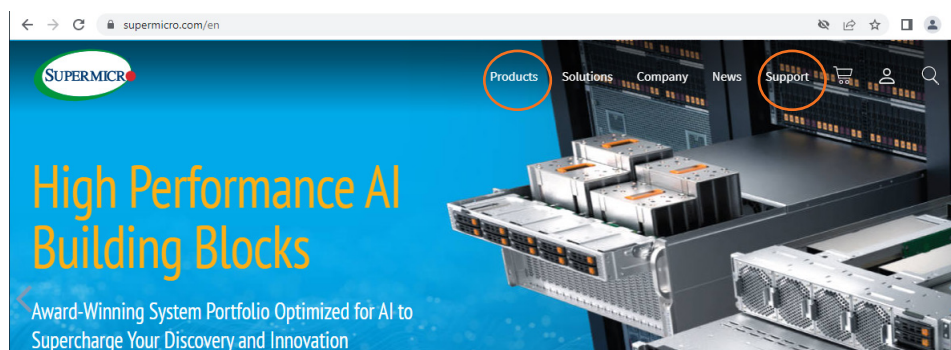

Figure 7-1. Supermicro Website

- Specifications for servers and other hardware are available by clicking the **Products** option.
- The **Support** option offers downloads (manuals, BIOS/BMC, drivers, etc.), FAQs, RMA, warranty, and other service extensions.

Direct Links for the SYS-F521E3-RTB System

SYS-F521E3-RTB web [specifications page](#)

X13SEFR-A [motherboard page](#) for links to the Quick Reference Guide, User Manual, [validated storage drives, etc.](#)

Direct Links for General Support and Information

[Frequently Asked Questions](#)

[TPM User Guide](#)

[General Memory Configuration Guide](#)

[BMC User Guide](#)

[SuperDoctor5 Large Deployment Guide](#)

For validated memory, use our [Product Resources page](#)

Direct Links (continued)

[Product Matrices](#) page for links to tables summarizing specs for systems, motherboards, power supplies, riser cards, add-on cards, etc.

[Security Center](#) for recent security notices

[Supermicro Phone and Addresses](#)

7.2 BMC Interface

The system supports a Baseboard Management Controller (BMC) interface. It provides remote access, monitoring and management. There are several BIOS settings related to the BMC.

For general documentation and information on the BMC, please visit our website at: www.supermicro.com/manuals/other/BMC_Users_Guide_X13.pdf.

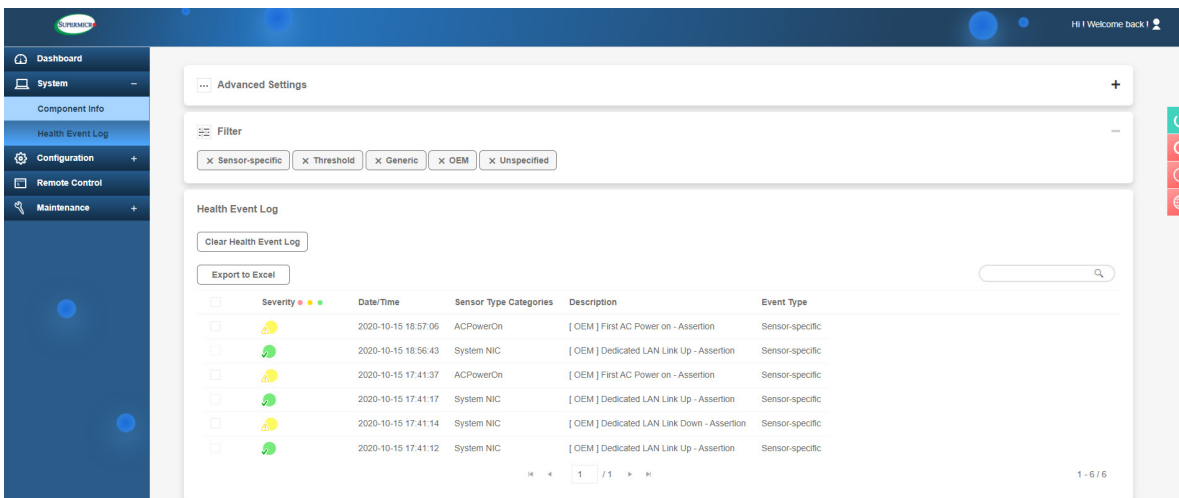

The screenshot shows the BMC Dashboard interface. On the left is a sidebar with navigation options: Dashboard, System, Component Info, Health Event Log, Configuration, Remote Control, and Maintenance. The main content area is titled 'Advanced Settings' and includes a 'Filter' section with buttons for 'Sensor-specific', 'Threshold', 'Generic', 'OEM', and 'Unspecified'. Below the filter is the 'Health Event Log' section, which contains a 'Clear Health Event Log' button and an 'Export to Excel' button. A table displays the event log data:

<input type="checkbox"/>	Severity	Date/Time	Sensor Type Categories	Description	Event Type
<input type="checkbox"/>	Warning	2020-10-15 18:57:06	ACPowerOn	[OEM] First AC Power on - Assertion	Sensor-specific
<input type="checkbox"/>	Info	2020-10-15 18:56:43	System NIC	[OEM] Dedicated LAN Link Up - Assertion	Sensor-specific
<input type="checkbox"/>	Warning	2020-10-15 17:41:37	ACPowerOn	[OEM] First AC Power on - Assertion	Sensor-specific
<input type="checkbox"/>	Info	2020-10-15 17:41:17	System NIC	[OEM] Dedicated LAN Link Up - Assertion	Sensor-specific
<input type="checkbox"/>	Warning	2020-10-15 17:41:14	System NIC	[OEM] Dedicated LAN Link Down - Assertion	Sensor-specific
<input type="checkbox"/>	Info	2020-10-15 17:41:12	System NIC	[OEM] Dedicated LAN Link Up - Assertion	Sensor-specific

The table has a search bar on the right and a pagination indicator at the bottom right showing '1 / 1'.

Figure 7-2. BMC Dashboard Sample

7.3 Troubleshooting Procedures

Use the following procedures to troubleshoot your system. If you have followed all of the procedures below and still need assistance, refer to the [Technical Support Procedures](#) or [Returning Merchandise for Service](#) sections in this chapter. [Power down](#) the system before changing any non hot-swap hardware components.

General Technique

If you experience unstable operation or get no boot response, try:

1. With power off, remove all but one DIMM and other added components, such as add-on cards, from the motherboard. Make sure the motherboard is not shorted to the chassis.
2. Set all jumpers to their default positions.
3. Power up. If the system boots, check for memory errors and add-on card problems.

No Power

- Check that the power LED on the motherboard is on.

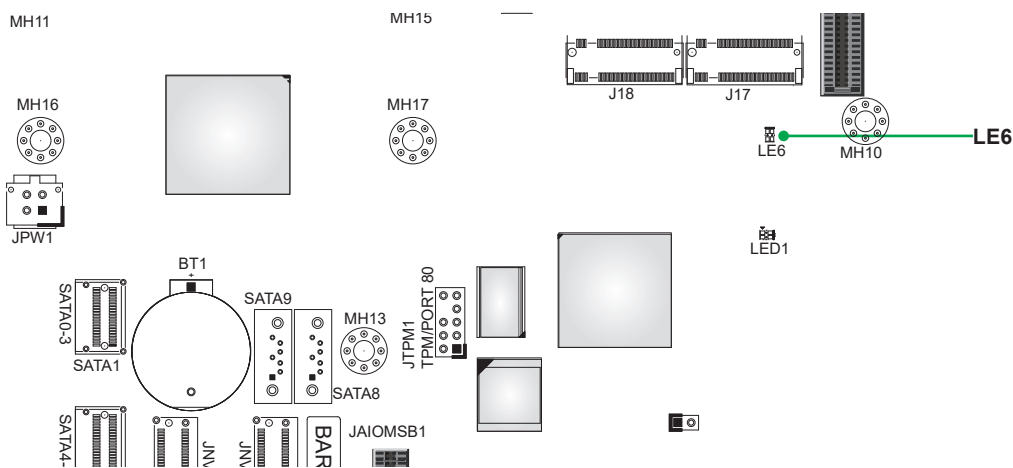

Figure 7-3. Location of the MB Power LED

- Make sure the the power supply is seated correctly and AC input cable is attached.
- Check that the motherboard battery still supplies approximately 3VDC. If it does not, replace it.
- Check that the system input voltage is 100-120v or 180-240v.
- Turn the power switch on and off to test the system

No Video

If the power is on but you have no video, remove all add-on cards and cables.

System Boot Failure

If the system does not display Power-On-Self-Test (POST) or does not respond after the power is turned on, try the following:

- Turn on the system with only one DIMM module installed. If the system boots, check for bad DIMM modules or slots by following the Memory Errors Troubleshooting procedure below.

Memory Errors

- Make sure that the DIMM modules are properly and fully installed.
- Confirm that you are using the correct memory. Also, it is recommended that you use the same memory type and speed for all DIMMs in the system. See Section 3.3 for memory details.
- Check for bad DIMM modules or slots by swapping modules between slots and noting the results.

Losing the System Setup Configuration

- Always replace power supplies with the exact same model that came with the system. A poor quality power supply may cause the system to lose the CMOS setup configuration.
- Check that the motherboard battery still supplies approximately 3VDC. If it does not, replace it.

If the above steps do not fix the setup configuration problem, contact your vendor for repairs.

When the System Becomes Unstable

If the system becomes unstable during or after OS installation, check the following:

- CPU/BIOS support: Make sure that your CPU is supported and that you have the latest BIOS installed in your system.
- Memory: Make sure that the memory modules are supported. Refer to the product page on our website at www.supermicro.com. Test the modules using **memtest86** or a similar utility.
- Storage drives: Make sure that all drives work properly. Replace if necessary.

- System cooling: Check that all heatsink fans and system fans work properly. Check the hardware monitoring settings in the BMC to make sure that the CPU and system temperatures are within the normal range. Also check the Control panel Overheat LED.
- Adequate power supply: Make sure that the power supply provides adequate power to the system. Make sure that all power connectors are connected. Refer to the Supermicro website for the minimum power requirements.
- Proper software support: Make sure that the correct drivers are used.

If the system becomes unstable before or during OS installation, check the following:

- Source of installation: Make sure that the devices used for installation are working properly, including boot devices.
- Cable connection: Check to make sure that all cables are connected and working properly.
- Use the minimum configuration for troubleshooting: Remove all unnecessary components (starting with add-on cards first), and use the minimum configuration (but with a CPU and a memory module installed) to identify the trouble areas.
- Identify a bad component by isolating it. Check and change one component at a time.
 - Remove a component in question from the chassis, and test it in isolation. Replace it if necessary.
 - Or swap in a new component for the suspect one.
 - Or install the possibly defective component into a known good system. If the new system works, the component is likely not the cause or the problem.

7.4 POST Codes

The AMI UEFI BIOS supplies checkpoint codes, which are documented online at <http://www.supermicro.com/support/manuals/> ("*AMI BIOS POST Codes User's Guide*").

When BIOS performs the Power On Self Test, it writes checkpoint codes to I/O port 0080h. If the computer cannot complete the boot process, the POST codes can be viewed from the BMC using the Post Snooping function.

For information on AMI updates, please refer to <http://www.ami.com/products/>.

7.5 Crash Dump Using the BMC Dashboard

In the event of a processor internal error (IERR) that crashes your system, you may want to provide information to support staff. You can download a crash dump of status information using the BMC Dashboard. The BMC manual is available at https://www.supermicro.com/manuals/other/BMC_Users_Guide_X12_H12.pdf.

Check Error Log

1. Access the BMC web interface.
2. Click the **Server Health** tab, then **Event Log** to verify an IERR error.

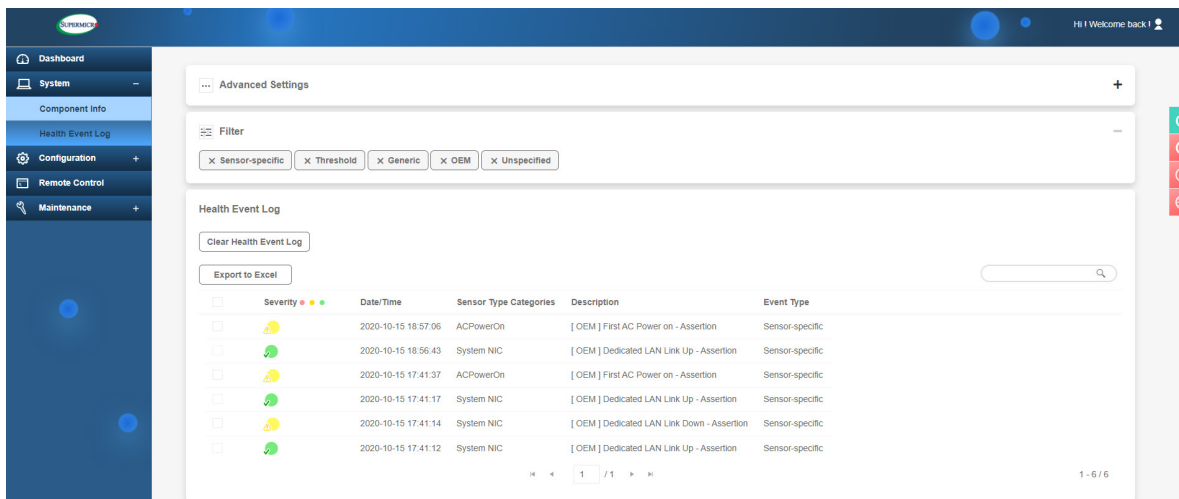

Figure 7-4. BMC Event Log

In the event of an IERR, the BMC executes a crash dump. You must download the crash dump and save it.

7.6 UEFI BIOS Recovery

Warning: Do not upgrade the BIOS unless your system has a BIOS-related issue. Flashing the wrong BIOS can cause irreparable damage to the system. In no event shall Supermicro be liable for direct, indirect, special, incidental, or consequential damages arising from a BIOS update. If you do update the BIOS, do not shut down or reset the system while the BIOS is updating to avoid possible boot failure.

Overview

The Unified Extensible Firmware Interface (UEFI) provides a software-based interface between the operating system and the platform firmware in the pre-boot environment. The UEFI specification supports an architecture-independent mechanism that will allow the UEFI OS loader stored in an add-on card to boot the system. The UEFI offers clean, hands-off management to a computer during system boot.

Recovering the UEFI BIOS Image

A UEFI BIOS flash chip consists of a recovery BIOS block and a main BIOS block (a main BIOS image). The recovery block contains critical BIOS codes, including memory detection and recovery codes for the user to flash a healthy BIOS image if the original main BIOS image is corrupted. When the system power is turned on, the recovery block codes execute first. Once this process is complete, the main BIOS code will continue with system initialization and the remaining POST (Power-On Self-Test) routines.

Note 1: Follow the BIOS recovery instructions below for BIOS recovery when the main BIOS block crashes.

Note 2: When the BIOS recovery block crashes, you will need to follow the procedures to make a Returned Merchandise Authorization (RMA) request. Also, you may use the Supermicro Update Manager (SUM) Out-of-Band (https://www.supermicro.com.tw/products/nfo/SMS_SUM.cfm) to reflash the BIOS.

Recovering the Main BIOS Block with a USB Device

This feature allows the user to recover the main BIOS image using a USB-attached device without additional utilities used. A USB flash or media drive can be used for this purpose. However, a USB hard disk drive cannot be used for BIOS recovery at this time.

The file system supported by the recovery block is FAT (including FAT12, FAT16, and FAT32) which is installed on a bootable or non-bootable USB-attached device. However, the BIOS might need several minutes to locate the SUPER.ROM file if the media size becomes too large due to the huge volumes of folders and files stored in the device.

To perform UEFI BIOS recovery using a USB-attached device, follow the instructions below.

1. Using a different machine, copy the "Super.ROM" binary image file into the disc Root "\ " directory of a USB flash or media drive.

Note 1: If you cannot locate the "Super.ROM" file in your drive disk, visit our website at www.supermicro.com to download the BIOS package. Extract the BIOS binary image into a USB flash device and rename it "Super.ROM" for the BIOS recovery use.

Note 2: Before recovering the main BIOS image, confirm that the "Super.ROM" binary image file you download is the same version or a close version meant for your motherboard.

2. Insert the USB device that contains the new BIOS image ("Super.ROM") into your USB drive and reset the system when the following screen appears.
3. After locating the healthy BIOS binary image, the system will enter the BIOS Recovery menu as shown below.



Note: At this point, you may decide if you want to start the BIOS recovery. If you decide to proceed with BIOS recovery, follow the procedures below.

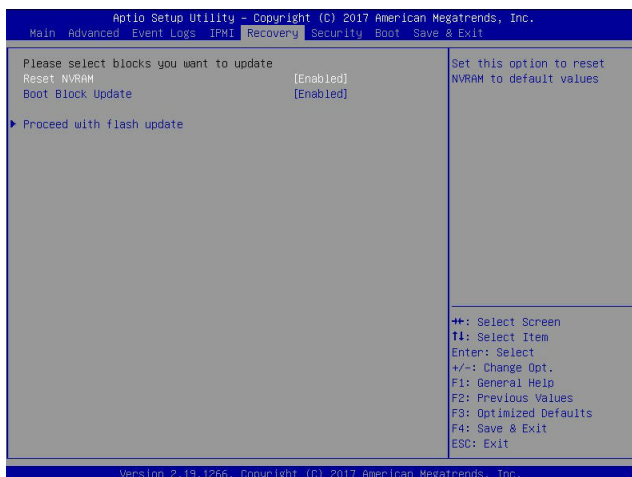

4. When the screen as shown above displays, use the arrow keys to select the item "Proceed with flash update" and press the <Enter> key. You will see the BIOS recovery progress as shown in the screen below.

Note: *Do not interrupt the BIOS flashing process until it has completed.*

5. After the BIOS recovery process is complete, press any key to reboot the system.
6. Using a different system, extract the BIOS package into a USB flash drive.

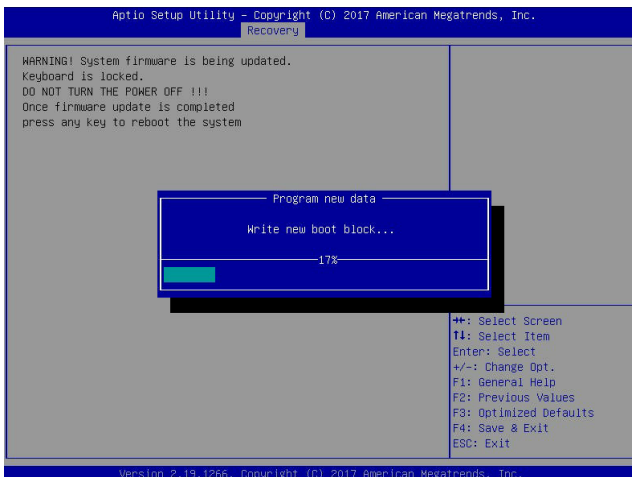

7. Press continuously during system boot to enter the BIOS Setup utility. From the top of the tool bar, select Boot to enter the submenu. From the submenu list, select Boot

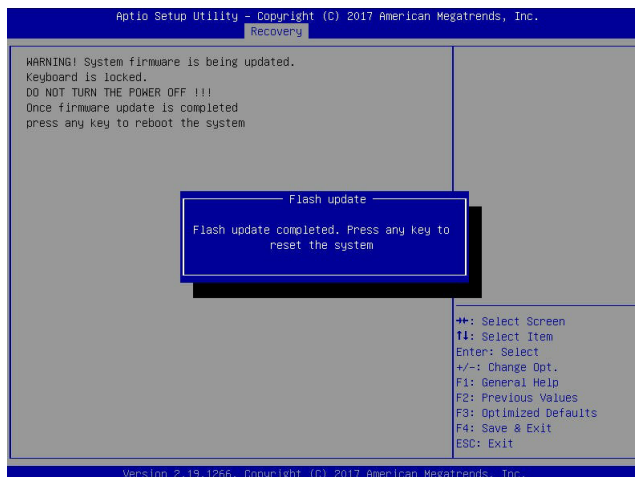

Option #1 as shown below. Then, set Boot Option #1 to [UEFI AP:UEFI: Built-in EFI Shell]. Press <F4> to save the settings and exit the BIOS Setup utility.

8. When the UEFI Shell prompt appears, type fs# to change the device directory path. Go to the directory that contains the BIOS package you extracted earlier from Step 6. Enter flash.nsh BIOSname.### at the prompt to start the BIOS update process.

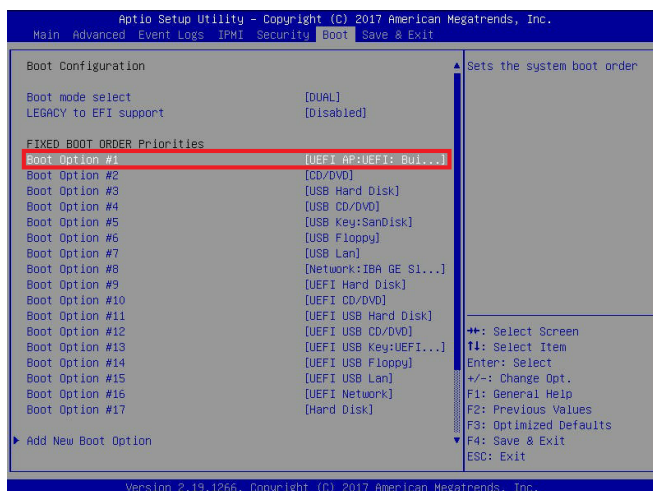

Note: *Do not interrupt this process* until the BIOS flashing is complete.

```

UEFI Interactive Shell v2.1
EDK II
UEFI v2.50 (American Megatrends, 0x0005000C)
Mapping table
  FS0: Alias(s):HD0:0:0:BLK1:
        PciRoot(0x0)/Pci(0x14,0x0)/USB(0x11,0x0)/HD(1,MBR,0x37901D72,0x800,0x1
CR9592)
  BLK0: Alias(s):
        PciRoot(0x0)/Pci(0x14,0x0)/USB(0x11,0x0)
Press F8 in 1 seconds to skip startup.nsh or any other key to continue.
Shell> fs0:
FS0:\> cd \AFUDOS
FS0:\AFUDOS> cd SNIJPM2_03162017
FS0:\AFUDOS\SNIJPM2_03162017> flash.nsh X110PU7_314

```

9. The screen above indicates that the BIOS update process is complete. When you see the screen above, unplug the AC power cable from the power supply, clear CMOS, and plug

```

Done.
[ Access Cmos Port Ex ]
<Read>
Index 0x51: 0x10

Done.
*****
*
* Program BIOS and ME (including FDT) regions...
*
*****
| AMT Firmware Update Utility v5.09.01.1917 |
| Copyright (C)2017 American Megatrends Inc. All Rights Reserved. |
*****
CPUID = 50652

Reading flash ..... done
- ME Data Size checking - ok
- FFS checksums ..... ok
- Check RomLayout ..... Ok
Erasing Boot Block ..... done
Updating Boot Block ..... done
Verifying Boot Block ..... done
_Erasing Main Block ..... 0x00132000 (0x)

```

the AC power cable in the power supply again to power on the system.

10. Press continuously to enter the BIOS Setup utility.

```

Verifying NDB Block ..... done
- Update success for FDR
- Update success for IE
- Successful Update Recovery Loader to OPRx11
- Successful Update MFSB11
- Successful Update FPR11
- Successful Update MFS, IVBI and IVB211
- Successful Update FLOG and UTDK11
- ME Entire Image update success !!
WARNING : System must power-off to have the changes take effect!
Moving F80:\AFUDOS\SNIJPM2_03162017\Fdtv64.efi -> F80:\AFUDOS\SNIJPM2_03162017\F
dt1.smc
- [ok]
Moving F80:\AFUDOS\SNIJPM2_03162017\Fuef1x64.efi -> F80:\AFUDOS\SNIJPM2_0316201
7\Fuef1.smc
- [ok]
*****
* Please ignore this 'Shell: Cannot read from file - Device Error'
* warning message due to it does not impact flashing process.
*
*****
Deleting "F:\SetupRom"
Delete successful.
FS0:\>

```

11. Press <F3> to load the default settings.
12. After loading the default settings, press <F4> to save the settings and exit the BIOS Setup utility.

7.7 CMOS Clear

JBT1 is used to clear CMOS, which will also clear any passwords. Instead of pins, this jumper consists of contact pads to prevent accidentally clearing the contents of CMOS.

To Clear CMOS

1. First [power down](#) the system completely.
2. [Remove the cover](#) of the chassis to access the motherboard.
3. [Remove the onboard battery](#) from the motherboard.
4. Short the CMOS pads with a metal object such as a small screwdriver for at least four seconds.
5. Remove the screwdriver or shorting device.
6. Replace the cover, reconnect the power cords and power on the system.



Notes: Clearing CMOS will also clear all passwords.

Do not use the PW_ON connector to clear CMOS.

7.8 BMC Reset

The BMC can be reset using the UID button.

- Reset – Press and hold the button. After six seconds, the LED blinks at 2Hz. The BMC resets and the reset duration is approximately 250 ms. Then the BMC starts to boot.
- Restore factory default configuration – Hold the button for twelve seconds. The LED blinks at 4Hz while defaults are configured. **Note:** All BMC settings including username and password will be removed except the FRU and network settings.

Firmware update – When the BMC firmware is being updated, the UID LED blinks at 10Hz.

BMC Reset Options		
Event	UID LED	BMC Heartbeat LED
Reset	Blue, Blinks at 2Hz	Green, solid
Restore Defaults	Blue, Blinks at 4Hz	Off
Update	Blue, Blinks at 10Hz	

7.9 Where to Get Replacement Components

If you need replacement parts for your system, to ensure the highest level of professional service and technical support, purchase exclusively from our Supermicro Authorized Distributors/System Integrators/Resellers. A list can be found at: <http://www.supermicro.com>. Click the "Where to Buy" tab.

7.10 Reporting an Issue

Technical Support Procedures

Before contacting Technical Support, please take the following steps. If your system was purchased through a distributor or reseller, please contact them for troubleshooting services. They have the best knowledge of your specific system configuration.

1. Please review the [Troubleshooting Procedures](#) in this manual and [Frequently Asked Questions](#) on our website before contacting Technical Support.
2. BIOS upgrades can be downloaded from our website. **Note:** Not all BIOS can be flashed depending on the modifications to the boot block code.
3. If you still cannot resolve the problem, include the following information when contacting us for technical support:
 - System, motherboard, and chassis model numbers and PCB revision number
 - BIOS release date/version (this can be seen on the initial display when your system first boots up)
 - System configuration

An example of a Technical Support form is posted on our [website](#). Distributors: For immediate assistance, please have your account number ready when contacting our technical support department by email.

Returning Merchandise for Service

A receipt or copy of your invoice marked with the date of purchase is required before any warranty service will be rendered. You can obtain service by calling your vendor for a Returned Merchandise Authorization (RMA) number. When returning to the manufacturer, the RMA number should be prominently displayed on the outside of the shipping carton, and mailed prepaid or hand-carried. Shipping and handling charges will be applied for all orders that must be mailed when service is complete.

For faster service, RMA authorizations may be requested online (<http://www.supermicro.com/support/rma/>).

Whenever possible, repack the chassis in the original Supermicro carton, using the original packaging material. If these are no longer available, be sure to pack the chassis securely, using packaging material to surround the chassis so that it does not shift within the carton and become damaged during shipping.

This warranty only covers normal consumer use and does not cover damages incurred in shipping or from failure due to the alteration, misuse, abuse or improper maintenance of products.

During the warranty period, contact your distributor first for any product problems.

Vendor Support Filing System

For issues related to Intel, use the Intel IPS filing system:

<https://www.intel.com/content/www/us/en/design/support/ips/training/welcome.html>

For issues related to Red Hat Enterprise Linux, since it is a subscription based OS, contact your account representative.

7.11 Feedback

Supermicro values your feedback as we strive to improve our customer experience in all facets of our business. To provide feedback on our manuals, please email us at techwriterteam@supermicro.com.

7.12 Contacting Supermicro

Headquarters

Address: Super Micro Computer, Inc.
980 Rock Ave.
San Jose, CA 95131 U.S.A.

Tel: +1 (408) 503-8000

Fax: +1 (408) 503-8008

Email: marketing@supermicro.com (General Information)
Sales-USA@supermicro.com (Sales Inquiries)
Government_Sales-USA@supermicro.com (Gov. Sales Inquiries)
support@supermicro.com (Technical Support)
RMA@supermicro.com (RMA Support)
Webmaster@supermicro.com (Webmaster)

Website: www.supermicro.com

Europe

Address: Super Micro Computer B.V.
Het Sterrenbeeld 28, 5215 ML
's-Hertogenbosch, The Netherlands

Tel: +31 (0) 73-6400390

Fax: +31 (0) 73-6416525

Email: Sales_Europe@supermicro.com (Sales Inquiries)
Support_Europe@supermicro.com (Technical Support)
RMA_Europe@supermicro.com (RMA Support)

Website: www.supermicro.nl

Asia-Pacific

Address: Super Micro Computer, Inc.
3F, No. 150, Jian 1st Rd.
Zhonghe Dist., New Taipei City 235
Taiwan (R.O.C)

Tel: +886-(2) 8226-3990

Fax: +886-(2) 8226-3992

Email: Sales-Asia@supermicro.com.tw (Sales Inquiries)
Support@supermicro.com.tw (Technical Support)
RMA@supermicro.com.tw (RMA Support)

Website: www.supermicro.com.tw

Appendix A

Standardized Warning Statements for AC Systems

About Standardized Warning Statements

The following statements are industry standard warnings, provided to warn the user of situations which have the potential for bodily injury. Should you have questions or experience difficulty, contact Supermicro's Technical Support department for assistance. Only certified technicians should attempt to install or configure components.

Read this appendix in its entirety before installing or configuring components in the Supermicro chassis.

These warnings may also be found on our website at http://www.supermicro.com/about/policies/safety_information.cfm.

Warning Definition



Warning! This warning symbol means danger. You are in a situation that could cause bodily injury. Before you work on any equipment, be aware of the hazards involved with electrical circuitry and be familiar with standard practices for preventing accidents.

警告の定義

この警告サインは危険を意味します。

人身事故につながる可能性がありますので、いずれの機器でも動作させる前に、電気回路に含まれる危険性に注意して、標準的な事故防止策に精通して下さい。

此警告符号代表危險。

您正处于可能受到严重伤害的工作环境中。在您使用设备开始工作之前，必须充分意识到触电的危险，并熟练掌握防止事故发生的标准工作程序。请根据每项警告结尾的声明号码找到此设备的安全性警告说明的翻译文本。

此警告符號代表危險。

您正處於可能身體可能會受損傷的工作環境中。在您使用任何設備之前，請注意觸電的危險，並且要熟悉預防事故發生的標準工作程序。請依照每一注意事項後的號碼找到相關的翻譯說明內容。

Warnung

WICHTIGE SICHERHEITSHINWEISE

Dieses Warnsymbol bedeutet Gefahr. Sie befinden sich in einer Situation, die zu Verletzungen führen kann. Machen Sie sich vor der Arbeit mit Geräten mit den Gefahren elektrischer Schaltungen und den üblichen Verfahren zur Vorbeugung vor Unfällen vertraut. Suchen Sie mit der am Ende jeder Warnung angegebenen Anweisungsnummer nach der jeweiligen Übersetzung in den übersetzten Sicherheitshinweisen, die zusammen mit diesem Gerät ausgeliefert wurden.

BEWAHREN SIE DIESE HINWEISE GUT AUF.

INSTRUCCIONES IMPORTANTES DE SEGURIDAD

Este símbolo de aviso indica peligro. Existe riesgo para su integridad física. Antes de manipular cualquier equipo, considere los riesgos de la corriente eléctrica y familiarícese con los procedimientos estándar de prevención de accidentes. Al final de cada advertencia encontrará el número que le ayudará a encontrar el texto traducido en el apartado de traducciones que acompaña a este dispositivo.

GUARDE ESTAS INSTRUCCIONES.

IMPORTANTES INFORMATIONS DE SÉCURITÉ

Ce symbole d'avertissement indique un danger. Vous vous trouvez dans une situation pouvant entraîner des blessures ou des dommages corporels. Avant de travailler sur un équipement, soyez conscient des dangers liés aux circuits électriques et familiarisez-vous avec les procédures couramment utilisées pour éviter les accidents. Pour prendre connaissance des traductions des avertissements figurant dans les consignes de sécurité traduites qui accompagnent cet appareil, référez-vous au numéro de l'instruction situé à la fin de chaque avertissement.

CONSERVEZ CES INFORMATIONS.

תקנון הזהרות אזהרה

הזהרות הבאות הן אזהרות על פי תקני התעשייה, על מנת להזהיר את המשתמש מפני חבלה פיזית אפשרית. במידה ויש שאלות או היתקלות בבעיה כלשהי, יש ליצור קשר עם מחלקת תמיכה טכנית של סופרמיקרו. טכנאים מוסמכים בלבד רשאים להתקין או להגדיר את הרכיבים. יש לקרוא את הנספח במלואו לפני התקנת או הגדרת הרכיבים במארזי סופרמיקרו.

اَكْ ف حالة وُكِي اَي تتسبب ف اصابة جسدهُ هذا الزهز عْ خطر! تحذُرُ .
 قبل اَي تعول على اَي هعدات، كي على علن بالوخاطز ال اَجوة عي الذوائر
 الكهزبائِة
 وكي على دراةُ بالووارسات النقاىِة لو عْ وقع اَي حادث
 استخدم رقن الب اى الو صُص ف هاةُ كل تحذُرُ للعشر تزجوتها

안전을 위한 주의사항

경고!

이 경고 기호는 위험이 있음을 알려 줍니다. 작업자의 신체에 부상을 야기 할 수 있는 상태에 있게 됩니다. 모든 장비에 대한 작업을 수행하기 전에 전기회로와 관련된 위험요소들을 확인하시고 사전에 사고를 방지할 수 있도록 표준 작업절차를 준수해 주시기 바랍니다.

해당 번역문을 찾기 위해 각 경고의 마지막 부분에 제공된 경고문 번호를 참조하십시오

BELANGRIJKE VEILIGHEIDSINSTRUCTIES

Dit waarschuwings symbool betekent gevaar. U verkeert in een situatie die lichamelijk letsel kan veroorzaken. Voordat u aan enige apparatuur gaat werken, dient u zich bewust te zijn van de bij een elektrische installatie betrokken risico's en dient u op de hoogte te zijn van de standaard procedures om ongelukken te voorkomen. Gebruik de nummers aan het eind van elke waarschuwing om deze te herleiden naar de desbetreffende locatie.

BEWAAR DEZE INSTRUCTIES

Installation Instructions



Warning! Read the installation instructions before connecting the system to the power source.

設置手順書

システムを電源に接続する前に、設置手順書をお読み下さい。

警告

将此系统连接电源前,请先阅读安装说明。

警告

將系統與電源連接前，請先閱讀安裝說明。

Warnung

Vor dem Anschließen des Systems an die Stromquelle die Installationsanweisungen lesen.

¡Advertencia!

Lea las instrucciones de instalación antes de conectar el sistema a la red de alimentación.

Attention

Avant de brancher le système sur la source d'alimentation, consulter les directives d'installation.

יש לקרוא את הוראות התקנה לפני חיבור המערכת למקור מתח.

اقر إرشادات التركيب قبل توصيل النظام إلى مصدر للطاقة

시스템을 전원에 연결하기 전에 설치 안내를 읽어주십시오.

Waarschuwing

Raadpleeg de installatie-instructies voordat u het systeem op de voedingsbron aansluit.

Circuit Breaker

Warning! This product relies on the building's installation for short-circuit (overcurrent) protection. Ensure that the protective device is rated not greater than: 250 V, 20 A.

サーキット・ブレーカー

この製品は、短絡(過電流)保護装置がある建物での設置を前提としています。

保護装置の定格が250 V、20 Aを超えないことを確認下さい。

警告

此产品的短路(过载电流)保护由建筑物的供电系统提供,确保短路保护设备的额定电流不大于250V,20A。

警告

此產品的短路(過載電流)保護由建築物的供電系統提供,確保短路保護設備的額定電流不大於250V,20A。

Warnung

Dieses Produkt ist darauf angewiesen, dass im Gebäude ein Kurzschluss- bzw. Überstromschutz installiert ist. Stellen Sie sicher, dass der Nennwert der Schutzvorrichtung nicht mehr als: 250 V, 20 A beträgt.

¡Advertencia!

Este equipo utiliza el sistema de protección contra cortocircuitos (o sobrecorrientes) del edificio. Asegúrese de que el dispositivo de protección no sea superior a: 250 V, 20 A.

Attention

Pour ce qui est de la protection contre les courts-circuits (surtension), ce produit dépend de l'installation électrique du local. Vérifiez que le courant nominal du dispositif de protection n'est pas supérieur à :250 V, 20 A.

מוצר זה מסתמך על הגנה המותקנת במבנים למניעת קצר חשמלי. יש לוודא כי המכשיר המגן מפני הקצר החשמלי הוא לא יותר מ-250VDC, 20A

هذا المنتج يعتمد على معدات الحماية مه الدوائر القصيرة التي تم تثبيتها في المبنى
تأكد من أن تقييم الجهاز الوقائي ليس أكثر من : 20A, 250V

경고!

이 제품은 전원의 단락(과전류)방지에 대해서 전적으로 건물의 관련 설비에 의존합니다. 보호장치의 정격이 반드시 250V(볼트), 20A(암페어)를 초과하지 않도록 해야 합니다.

Waarschuwing

Dit product is afhankelijk van de kortsluitbeveiliging (overspanning) van uw elektrische installatie. Controleer of het beveiligde apparaat niet groter gedimensioneerd is dan 250V, 20A.

Power Disconnection Warning



Warning! The system must be disconnected from all sources of power and the power cord removed from the power supply module(s) before accessing the chassis interior to install or remove system components.



電源切斷の警告

システムコンポーネントの取り付けまたは取り外しのために、シャーシ内部にアクセスするには、システムの電源はすべてのソースから切斷され、電源コードは電源モジュールから取り外す必要があります。

警告

在你打开机箱并安装或移除内部器件前,必须将系统完全断电,并移除电源线。

警告

在您打開機殼安裝或移除內部元件前，必須將系統完全斷電，並移除電源線。

Warnung

Das System muss von allen Quellen der Energie und vom Netzanschlusskabel getrennt sein, das von den Spg.Versorgungsteilmodulen entfernt wird, bevor es auf den Chassisinnenraum zurückgreift, um Systemsbestandteile anzubringen oder zu entfernen.

¡Advertencia!

El sistema debe ser disconnected de todas las fuentes de energía y del cable eléctrico quitado de los módulos de fuente de alimentación antes de tener acceso el interior del chasis para instalar o para quitar componentes de sistema.

Attention

Le système doit être débranché de toutes les sources de puissance ainsi que de son cordon d'alimentation secteur avant d'accéder à l'intérieur du chasis pour installer ou enlever des composants de système.

אזהרה מפני ניתוק חשמלי

!אזהרה

יש לנתק את המערכת מכל מקורות החשמל ויש להסיר את כבל החשמלי מהספק לפני גישה לחלק הפנימי של המארז לצורך התקנת או הסרת רכיבים.

يجب فصل انظاؤ من جميع مصادر انطاقت وإزانت سهك انكهرباء من وحدة امداد انطاقت قيم

انصل إلى امنطاقت انداخهيت نههيكم نتشيج أو إزانت مكناث الجهاز

경고!

시스템에 부품들을 장착하거나 제거하기 위해서는 새시 내부에 접근하기 전에 반드시 전원 공급장치로부터 연결되어있는 모든 전원과 전기코드를 분리해주어야 합니다.

Waarschuwing

Voordat u toegang neemt tot het binnenwerk van de behuizing voor het installeren of verwijderen van systeem onderdelen, dient u alle spanningsbronnen en alle stroomkabels aangesloten op de voeding(en) van de behuizing te verwijderen

Equipment Installation



Warning! Only trained and qualified personnel should be allowed to install, replace, or service this equipment.

機器の設置

トレーニングを受け認定された人だけがこの装置の設置、交換、またはサービスを許可されていません。

警告

只有经过培训且具有资格的人员才能进行此设备的安装、更换和维修。

警告

只有經過受訓且具資格人員才可安裝、更換與維修此設備。

Warnung

Das Installieren, Ersetzen oder Bedienen dieser Ausrüstung sollte nur geschultem, qualifiziertem Personal gestattet werden.

¡Advertencia!

Solamente el personal calificado debe instalar, reemplazar o utilizar este equipo.

Attention

Il est vivement recommandé de confier l'installation, le remplacement et la maintenance de ces équipements à des personnels qualifiés et expérimentés.

אזהרה!

צוות מוסמך בלבד רשאי להתקין, להחליף את הציוד או לתת שירות עבור הציוד.

والمدربيه لتزكيب واستبدال أو خدمة هذا الجهاز يجب أن يسمح فقط للمظفيه المؤهليه

경고!

훈련을 받고 공인된 기술자만이 이 장비의 설치, 교체 또는 서비스를 수행할 수 있습니다.

Waarschuwing

Deze apparatuur mag alleen worden geïnstalleerd, vervangen of hersteld door geschoold en gekwalificeerd personeel.

Restricted Area



Warning! This unit is intended for installation in restricted access areas. A restricted access area can be accessed only through the use of a special tool, lock and key, or other means of security. (This warning does not apply to workstations).

アクセス制限区域

このユニットは、アクセス制限区域に設置されることを想定しています。

アクセス制限区域は、特別なツール、鍵と錠前、その他のセキュリティの手段を用いてのみ出入りが可能です。

警告

此部件应安装在限制进出的场所，限制进出的场所指只能通过使用特殊工具、锁和钥匙或其它安全手段进出的场所。

警告

此装置仅限安装於進出管制區域，進出管制區域係指僅能以特殊工具、鎖頭及鑰匙或其他安全方式才能進入的區域。

Warnung

Diese Einheit ist zur Installation in Bereichen mit beschränktem Zutritt vorgesehen. Der Zutritt zu derartigen Bereichen ist nur mit einem Spezialwerkzeug, Schloss und Schlüssel oder einer sonstigen Sicherheitsvorkehrung möglich.

¡Advertencia!

Esta unidad ha sido diseñada para instalación en áreas de acceso restringido. Sólo puede obtenerse acceso a una de estas áreas mediante la utilización de una herramienta especial, cerradura con llave u otro medio de seguridad.

Attention

Cet appareil doit être installée dans des zones d'accès réservés. L'accès à une zone d'accès réservé n'est possible qu'en utilisant un outil spécial, un mécanisme de verrouillage et une clé, ou tout autre moyen de sécurité.

אזור עם גישה מוגבלת

אזהרה!

יש להתקין את היחידה באזורים שיש בהם הגבלת גישה. הגישה ניתנת בעזרת 'כלי אבטחה בלבד' (מפתח, מנעול וכד.).

تخصيص هذه انحدة نترك بها ف مناطق محظورة تم .

،ممكن اننصل إن منطقت محظورة فقط من خلال استخذاو أداة خاصت أو أ وس هُت أخري نلالأمما ققم ومفتاح

경고!

이 장치는 접근이 제한된 구역에 설치하도록 되어있습니다. 특수도구, 잠금 장치 및 키, 또는 기타 보안 수단을 통해서만 접근 제한 구역에 들어갈 수 있습니다.

Waarschuwing

Dit apparaat is bedoeld voor installatie in gebieden met een beperkte toegang. Toegang tot dergelijke gebieden kunnen alleen verkregen worden door gebruik te maken van speciaal gereedschap, slot en sleutel of andere veiligheidsmaatregelen.

Battery Handling



Warning! There is the danger of explosion if the battery is replaced incorrectly. Replace the battery only with the same or equivalent type recommended by the manufacturer. Dispose of used batteries according to the manufacturer's instructions

電池の取り扱い

電池交換が正しく行われなかった場合、破裂の危険性があります。交換する電池はメーカーが推奨する型、または同等のものを使用下さい。使用済電池は製造元の指示に従って処分して下さい。

警告

電池更換不當會有爆炸危險。請只使用同類電池或制造商推薦的功能相當的電池更換原有電池。請按製造商的說明處理廢舊電池。

警告

電池更換不當會有爆炸危險。請使用製造商建議之相同或功能相當的電池更換原有電池。請按照製造商的說明指示處理廢棄舊電池。

Warnung

Bei Einsetzen einer falschen Batterie besteht Explosionsgefahr. Ersetzen Sie die Batterie nur durch den gleichen oder vom Hersteller empfohlenen Batterietyp. Entsorgen Sie die benutzten Batterien nach den Anweisungen des Herstellers.

Attention

Danger d'explosion si la pile n'est pas remplacée correctement. Ne la remplacer que par une pile de type semblable ou équivalent, recommandée par le fabricant. Jeter les piles usagées conformément aux instructions du fabricant.

¡Advertencia!

Existe peligro de explosión si la batería se reemplaza de manera incorrecta. Reemplazar la batería exclusivamente con el mismo tipo o el equivalente recomendado por el fabricante. Desechar las baterías gastadas según las instrucciones del fabricante.

אזהרה!

קיימת סכנת פיצוץ של הסוללה במידה והוחלפה בדרך לא תקינה. יש להחליף את הסוללה בסוג התואם מחברת יצרן מומלצת. סילוק הסוללות המשומשות יש לבצע לפי הוראות היצרן.

هناك خطر من انفجار في حالة اسبدال البطارية بطريقة غير صحيحة فعلى
اسبدال البطارية
فقط بنفس النوع أو ما يعادلها مما أوصت به الشركة المصنعة
جخلص من البطاريات المسحومة وفقا لعمليات الشركة الصانعة

경고!

배터리가 올바르게 교체되지 않으면 폭발의 위험이 있습니다. 기존 배터리와 동일하거나 제조사에서 권장하는 동등한 종류의 배터리로만 교체해야 합니다. 제조사의 안내에 따라 사용된 배터리를 처리하여 주십시오.

Waarschuwing

Er is ontplofingsgevaar indien de batterij verkeerd vervangen wordt. Vervang de batterij slechts met hetzelfde of een equivalent type die door de fabrikant aanbevolen wordt. Gebruikte batterijen dienen overeenkomstig fabrieksvoorschriften afgevoerd te worden.

Redundant Power Supplies



Warning! This unit might have more than one power supply connection. All connections must be removed to de-energize the unit.

冗長電源装置

このユニットは複数の電源装置が接続されている場合があります。

ユニットの電源を切るためには、すべての接続を取り外さなければなりません。

警告

此部件连接的电源可能不止一个，必须将所有电源断开才能停止给该部件供电。

警告

此装置连接的电源可能不只一个，必须切断所有电源才能停止对该装置的供电。

Warnung

Dieses Gerät kann mehr als eine Stromzufuhr haben. Um sicherzustellen, dass der Einheit kein Strom zugeführt wird, müssen alle Verbindungen entfernt werden.

¡Advertencia!

Puede que esta unidad tenga más de una conexión para fuentes de alimentación. Para cortar por completo el suministro de energía, deben desconectarse todas las conexiones.

Attention

Cette unité peut avoir plus d'une connexion d'alimentation. Pour supprimer toute tension et tout courant électrique de l'unité, toutes les connexions d'alimentation doivent être débranchées.

אם קיים יותר מספק אחד

אזהרה!

ליחידה יש יותר מחיבור אחד של ספק. יש להסיר את כל החיבורים על מנת לרוקן את היחידה.

قد يكون لهذا الجهاز عدة اتصالات بوحدات امداد الطاقة .

يجب إزالة كافة الاتصالات لعسل الوحدة عن الكهرباء

경고!

이 장치에는 한 개 이상의 전원 공급 단자가 연결되어 있을 수 있습니다. 이 장치에 전원을 차단하기 위해서는 모든 연결 단자를 제거해야만 합니다.

Waarschuwing

Deze eenheid kan meer dan één stroomtoevoeraansluiting bevatten. Alle aansluitingen dienen verwijderd te worden om het apparaat stroomloos te maken.

Backplane Voltage



Warning! Hazardous voltage or energy is present on the backplane when the system is operating. Use caution when servicing.

バックプレーンの電圧

システムの稼働中は危険な電圧または電力が、バックプレーン上にかかっています。

修理する際には注意ください。

警告

当系统正在进行时，背板上有很危险的电压或能量，进行维修时务必小心。

警告

當系統正在進行時，背板上有危險的電壓或能量，進行維修時務必小心。

Warnung

Wenn das System in Betrieb ist, treten auf der Rückwandplatine gefährliche Spannungen oder Energien auf. Vorsicht bei der Wartung.

¡Advertencia!

Cuando el sistema está en funcionamiento, el voltaje del plano trasero es peligroso. Tenga cuidado cuando lo revise.

Attention

Lorsque le système est en fonctionnement, des tensions électriques circulent sur le fond de panier. Prendre des précautions lors de la maintenance.

מתח בפנל האחורי

אזהרה!

קיימת סכנת מתח בפנל האחורי בזמן תפעול המערכת. יש להיזהר במהלך העבודה.

هناك خطر من التيار الكهربائي أو الطاقة المتجددة على اللوحة
عندما يكون النظام يعمل كه حذرا عند خدمة هذا الجهاز

경고!

시스템이 동작 중일 때 후면판 (Backplane)에는 위험한 전압이나 에너지가 발생 합니다.
서비스 작업 시 주의하십시오.

Waarschuwing

Een gevaarlijke spanning of energie is aanwezig op de backplane wanneer het systeem in gebruik is. Voorzichtigheid is geboden tijdens het onderhoud.

Comply with Local and National Electrical Codes



Warning! Installation of the equipment must comply with local and national electrical codes.

地方および国の電気規格に準拠

機器の取り付けはその地方および国の電気規格に準拠する必要があります。

警告

设备安装必须符合本地与本国电气法规。

警告

設備安裝必須符合本地與本國電氣法規。

Warnung

Die Installation der Geräte muss den Sicherheitsstandards entsprechen.

¡Advertencia!

La instalación del equipo debe cumplir con las normas de electricidad locales y nacionales.

Attention

L'équipement doit être installé conformément aux normes électriques nationales et locales.

תיאום חוקי החשמל הארצי
אזהרה!
התקנת הציוד חייבת להיות תואמת לחוקי החשמל המקומיים והארציים.

تركيب المعدات الكهربائية يجب أن يمتثل للقوايه المحلية والبطية المتعلقة
بالكهرباء

경고!

현 지역 및 국가의 전기 규정에 따라 장비를 설치해야 합니다.

Waarschuwing

Bij installatie van de apparatuur moet worden voldaan aan de lokale en nationale elektriciteitsvoorschriften.

Product Disposal



Warning! Ultimate disposal of this product should be handled according to all national laws and regulations.

製品の廃棄

この製品を廃棄処分する場合、国の関係する全ての法律・条例に従い処理する必要があります。

警告

本产品的废弃处理应根据所有国家的法律和规章进行。

警告

本產品的廢棄處理應根據所有國家的法律和規章進行。

Warnung

Die Entsorgung dieses Produkts sollte gemäß allen Bestimmungen und Gesetzen des Landes erfolgen.

¡Advertencia!

Al deshacerse por completo de este producto debe seguir todas las leyes y reglamentos nacionales.

Attention

La mise au rebut ou le recyclage de ce produit sont généralement soumis à des lois et/ou directives de respect de l'environnement. Renseignez-vous auprès de l'organisme compétent.

סילוק המוצר

אזהרה!

סילוק סופי של מוצר זה חייב להיות בהתאם להנחיות וחוקי המדינה.

التخلص النهائي من هذا المنتج ينبغي التعامل معه وفقا لجميع القوانين واللوائح الوطنية عند

경고!

이 제품은 해당 국가의 관련 법규 및 규정에 따라 폐기되어야 합니다.

Waarschuwing

De uiteindelijke verwijdering van dit product dient te geschieden in overeenstemming met alle nationale wetten en reglementen.

Hot Swap Fan Warning



Warning! Hazardous moving parts. Keep away from moving fan blades. The fans might still be turning when you remove the fan assembly from the chassis. Keep fingers, screwdrivers, and other objects away from the openings in the fan assembly's housing.

ファン・ホットスワップの警告

警告!回転部品に注意。運転中は回転部(羽根)に触れないでください。シャーシから冷却ファン装置を取り外した際、ファンがまだ回転している可能性があります。ファンの開口部に、指、ドライバー、およびその他のものを近づけないで下さい。

警告!

警告! 危險的可移動性零件。請務必與轉動的风扇叶片保持距離。當您從機架移除風扇裝置，風扇可能仍在轉動。小心不要將手指、螺絲起子和其他物品太靠近風扇

警告

危險的可移動性零件。請務必與轉動的风扇叶片保持距離。當您從機架移除風扇裝置，風扇可能仍在轉動。小心不要將手指、螺絲起子和其他物品太靠近風扇。

Warnung

Gefährlich Bewegende Teile. Von den bewegenden Lüfterblätter fern halten. Die Lüfter drehen sich u. U. noch, wenn die Lüfterbaugruppe aus dem Chassis genommen wird. Halten Sie Finger, Schraubendreher und andere Gegenstände von den Öffnungen des Lüftergehäuses entfernt.

¡Advertencia!

Riesgo de piezas móviles. Mantener alejado de las aspas del ventilador. Los ventiladores podran dar vuelta cuando usted quite el montaje del ventilador del chasis. Mantenga los dedos, los destornilladores y todos los objetos lejos de las aberturas del ventilador

Attention

Pieces mobiles dangereuses. Se tenir a l'écart des lames du ventilateur Il est possible que les ventilateurs soient toujours en rotation lorsque vous retirerez le bloc ventilateur du châssis. Prenez garde à ce que doigts, tournevis et autres objets soient éloignés du logement du bloc ventilateur.

אזהרה!

חלקים נעים מסוכנים. התרחק מלהבי המאוורר בפעולה כאשר מסירים את חלקי המאוורר מהמארז, יתכן והמאווררים עדיין עובדים. יש להרחיק למרחק בטוח את האצבעות וכלי עבודה שונים מהפתחים בתוך המאוורר

تحذير! أجزاء متحركة خطيرة. ابتعد عن شفرات المروحة المتحركة. من الممكن أن المراوح لا تزال تدور عند إزالة كتلة المروحة من الهيكل يجب إبقاء الأصابع ومفكات البراغي وغيرها من الأشياء بعيدا عن الفتحات في كتلة المروحة

경고!

움직이는 위험한 부품. 회전하는 송풍 날개에 접근하지 마세요. 새시로부터 팬 조립품을 제거할 때 팬은 여전히 회전하고 있을 수 있습니다. 팬 조립품 외관의 열려있는 부분들로부터 손가락 및 스크류드라이버, 다른 물체들이 가까이 하지 않도록 배치해 주십시오.

Waarschuwing

Gevaarlijk bewegende onderdelen. Houd voldoende afstand tot de bewegende ventilatorbladen. Het is mogelijk dat de ventilator nog draait tijdens het verwijderen van het ventilatorsamenstel uit het chassis. Houd uw vingers, schroevendraaiers en eventuele andere voorwerpen uit de buurt van de openingen in de ventilatorbehuizing.

Power Cable and AC Adapter



Warning! When installing the product, use the provided or designated connection cables, power cables and AC adaptors. Using any other cables and adaptors could cause a malfunction or a fire. Electrical Appliance and Material Safety Law prohibits the use of UL or CSA -certified cables (that have UL/CSA shown on the cord) for any other electrical devices than products designated by Supermicro only.

電源コードとACアダプター

製品を設置する場合、提供または指定および購入された接続ケーブル、電源コードとACアダプターを、該当する地域の条例や安全基準に適合するコードサイズやプラグと共に使用下さい。他のケーブルやアダプタを使用すると故障や火災の原因になることがあります。

電気用品安全法は、ULまたはCSA認定のケーブル(UL/CSAマークがコードに表記)を Supermicro が指定する製品以外に使用することを禁止しています。

警告

安装此产品时,请使用本身提供的或指定的或采购的连接线,电源线和电源适配器。包含遵照当地法规和安全要求的合规的电源线尺寸和插头。使用其它线材或适配器可能会引起故障或火灾。除了Supermicro所指定的产品,电气用品和材料安全法律规定禁止使用未经UL或CSA认证的线材。(线材上会显示UL/CSA符号)。

警告

安裝此產品時,請使用本身提供的或指定的或採購的連接線,電源線和電源適配器。包含遵照當地法規和安全要求的合規的電源線尺寸和插頭。使用其它線材或適配器可能會引起故障或火災。除了Supermicro所指定的產品,電氣用品和材料安全法律規定禁止使用未經UL或CSA認證的線材。(線材上會顯示UL/CSA符號)。

Warnung

Nutzen Sie beim Installieren des Produkts ausschließlich die von uns zur Verfügung gestellten Verbindungskabeln, Stromkabeln und/oder Adapter, die Ihre örtlichen Sicherheitsstandards einhalten. Der Gebrauch von anderen Kabeln und Adapter können Fehlfunktionen oder Feuer verursachen. Die Richtlinien untersagen das Nutzen von UL oder CAS zertifizierten Kabeln (mit UL/CSA gekennzeichnet), an Geräten oder Produkten die nicht mit Supermicro gekennzeichnet sind.

¡Advertencia!

Cuando instale el producto, utilice la conexión provista o designada o procure cables, Cables de alimentación y adaptadores de CA que cumplan con los códigos locales y los requisitos de seguridad, incluyendo el tamaño adecuado del cable y el enchufe. El uso de otros cables y adaptadores podría causar un mal funcionamiento o un incendio. La Ley de Seguridad de Aparatos Eléctricos y de Materiales prohíbe El uso de cables certificados por UL o CSA (que tienen el certificado UL / CSA en el código) para cualquier otros dispositivos eléctricos que los productos designados únicamente por Supermicro.

Attention

Lors de l'installation du produit, utilisez les cables de connection fournis ou désigné ou achetez des cables, cables de puissance et adaptateurs respectant les normes locales et les conditions de securite y compris les tailles de cables et les prises electriques appropriées. L'utilisation d'autres cables et adaptateurs peut provoquer un dysfonctionnement ou un incendie. Appareils électroménagers et la Loi sur la Sécurité Matériel interdit l'utilisation de câbles certifiés- UL ou CSA (qui ont UL ou CSA indiqué sur le code) pour tous les autres appareils électriques sauf les produits désignés par Supermicro seulement.

AC ימאתמו מיילמשח מילבכ

!הרהזא

ךרוצל ומאתוה וא ושכרנ רשא AC מימאתמו מיקפס, מילבכב שמתשהל שי, רצומה תא מיניקתמ רשאכ לכב שומיש . עקתהו לבכה לש הנוכח הדימ ללוכ, תוימוקמה תוחיטבה תושירדל ומאתוה רשאו, הנקתהה למשחה ירישכמב שומישה יקוחל מאתהב. ילמשח רצק וא הלקתל מורגל לולע, רחא גוסמ מאתמ וא לבכ לש דוק מהילע עיפומ רשאכ) UL-ב או CSA-ב (ב-UL מיכמומה מילבכב שמתשהל רוסיא מייק, תוחיטבה יקוחו דבלב Supermicro י"ע מאתוה רשא רצומב קר אלא, רחא ילמשח רצומ לכ רובע UL/CSA)

תאלבאלא אארשב מץ וא אדדחמלא וא ארפוטמלא תאליטוטלא מאדחטסאב מץ, אגתנמלא בייקרת דנע לכלז יפאמב אילחמלא אלאסלא תאבלטתמו נינאווקב מאזתלאלא אג דדרתמלא ראיטלא תאלוחמו אילברמלא קיירח וא לטע יפאבבסטטי דקיירחא תאלוחמו תאלבאלא יא מאדחטסא. מילסלא סבאלאו לטומוא מץח CSA וא UL לביק נמ אדמתמלא תאלבאלא מאדחטסא תאדעמלא אילברמלא אזהאלל אלאסלא נונאק רזחי Supermicro לביק נמ אדדחמלא אילחמלא תאגתנמלא ריגיירחא תאדעמ יא אג (UL/CSA) אלאע למחתיטלאו

전원 케이블 및 AC 어댑터

경고! 제품을 설치할 때 현지 코드 및 적절한 굵기의 코드와 플러그를 포함한 안전 요구 사항을 준수하여 제공되거나 지정된 연결 혹은 구매 케이블, 전원 케이블 및 AC 어댑터를 사용하십시오.

다른 케이블이나 어댑터를 사용하면 오작동이나 화재가 발생할 수 있습니다. 전기 용품 안전법은 UL 또는 CSA 인증 케이블 (코드에 UL / CSA가 표시된 케이블)을 Supermicro 가 지정한 제품 이외의 전기 장치에 사용하는 것을 금지합니다.

Stroomkabel en AC-Adapter

Waarschuwing! Bij het aansluiten van het Product uitsluitend gebruik maken van de geleverde Kabels of een andere geschikte aan te schaffen Aansluitmethode, deze moet altijd voldoen aan de lokale voorschriften en veiligheidsnormen, inclusief de juiste kabeldikte en stekker. Het gebruik van niet geschikte Kabels en/of Adapters kan een storing of brand veroorzaken. Wetgeving voor Elektrische apparatuur en Materiaalveiligheid verbied het gebruik van UL of CSA -gecertificeerde Kabels (met UL/CSA in de code) voor elke andere toepassing dan de door Supermicro hiervoor beoogde Producten.

Appendix B

System Specifications

Processors *(per node)*

Single 4th Generation Intel Xeon Scalable processor in a E (LGA-4677) socket with up to 60 cores and a thermal design power (TDP) of up to 350W, Note: Refer to the motherboard specifications pages on our website for updates.

Chipset

Intel C741

BIOS

256Mb SPI AMI BIOS, ACPI 6.0, Plug and Play (PnP), BIOS rescue hot-key, riser card auto detection support, and SMBIOS 3.0 or later

Memory *(per node)*

Up to 4TB of ECC RDIMM/RDIMM 3DS DDR5 memory with speeds of up to 4800MT/s (DDR5-4400MT/s when fully populated) in 16 memory slots

Storage Drives *(per node)*

Six 2.5" hot-swap NVMe/SATA/SAS drive bays

Two M.2 NVMe or SATA

PCI Expansion Slots *(per node)*

One AIOM (OCP 3.0) slot

One PCIe 4.0 x16 LP external slot

Input/Output *(per node)*

Network: Quantity of LAN ports varies by AIOM card

BMC: Dedicated LAN port

USB: Two USB 3.1 ports

Video: One VGA port

COM port: One serial header

Motherboard *(per node)*

X13SEFR-A; 18" (W) x 8.4" (L) (457mm x 214mm), proprietary

Chassis

CSE-F418BC4-R2K08BP; 4U Rackmount, 17.6 x 7.0 x 29in. / 448 x 177 x 737mm (WxHxD)

System Cooling *(per node)*

Two 8-cm fans fans with Optimal Fan Speed Control, one CPU heatsink, two air shrouds to direct air flow

Power Supply

Model: Four PWS-2K08A-1R, 2000W redundant modules, 80Plus Titanium level

AC Input

100-127 Vac, 50-60 Hz

200-240 Vac, 50-60 Hz

+12V

1000W (100 - 127Vac), 83A

1800W (200 - 220Vac), 150A

1980W (220 - 230Vac), 165A

2000W (220 - 240Vac), 165A

2000W (230 - 240Vdc)

2000W (230 - 240Vac)

+12 V standby: 3.5A

Operating Environment

Operating Temperature: 10° to 35° C (50° to 95° F)

Non-operating Temperature: -40° to 60° C (-40° to 140° F)

Operating Relative Humidity: 8% to 90% (non-condensing)

Non-operating Relative Humidity: 5% to 95% (non-condensing)

Regulatory Compliance

FCC, ICES, CE, UKCA, VCCI, RCM, NRTL, CB

Certified Safety Models

Compliant with UL and CSA: F424R-Q20X13, F424-FT, F424-20

Applied Directives, Standards

EMC/EMI: 2014/30/EU (EMC Directive)

Electromagnetic Compatibility Regulations 2016

FCC Part 15

ICES-003

VCCI-CISPR 32

AS/NZS CISPR 32

BS/EN55032

BS/EN55035

CISPR 32

CISPR 35

BS/EN 61000-3-2

BS/EN 61000-3-3

BS/EN 61000-4-2

BS/EN 61000-4-3

BS/EN 61000-4-4

BS/EN 61000-4-5

BS/EN 61000-4-6

BS/EN 61000-4-8

BS/EN 61000-4-11

Environment:

2011/65/EU (RoHS Directive)

EC 1907/2006 (REACH)

2012/19/EU (WEEE Directive)

California Proposition 65

Product Safety: 2014/35/EU (LVD Directive)

UL/CSA 62368-1 (USA and Canada)

Electrical Equipment (Safety) Regulations 2016

IEC/BS/EN 62368-1

Perchlorate Warning

California Best Management Practices Regulations for Perchlorate Materials: This Perchlorate warning applies only to products containing CR (Manganese Dioxide) Lithium coin cells. "Perchlorate Material-special handling may apply. See www.dtsc.ca.gov/hazardouswaste/perchlorate"

この装置は、クラスA機器です。この装置を住宅環境で使用すると電波妨害を引き起こすことがあります。この場合には使用者が適切な対策を講ずるよう要求されることがあります。

VCCI — A