



# SuperServer<sup>®</sup> ARS-221GL-SR



USER'S MANUAL

Revision 1.0

The information in this User's Manual has been carefully reviewed and is believed to be accurate. The vendor assumes no responsibility for any inaccuracies that may be contained in this document, and makes no commitment to update or to keep current the information in this manual, or to notify any person or organization of the updates. Please Note: For the most up-to-date version of this manual, please see our website at [www.supermicro.com](http://www.supermicro.com).

Super Micro Computer, Inc. ("Supermicro") reserves the right to make changes to the product described in this manual at any time and without notice. This product, including software and documentation, is the property of Supermicro and/or its licensors, and is supplied only under a license. Any use or reproduction of this product is not allowed, except as expressly permitted by the terms of said license.

IN NO EVENT WILL Super Micro Computer, Inc. BE LIABLE FOR DIRECT, INDIRECT, SPECIAL, INCIDENTAL, SPECULATIVE OR CONSEQUENTIAL DAMAGES ARISING FROM THE USE OR INABILITY TO USE THIS PRODUCT OR DOCUMENTATION, EVEN IF ADVISED OF THE POSSIBILITY OF SUCH DAMAGES. IN PARTICULAR, SUPER MICRO COMPUTER, INC. SHALL NOT HAVE LIABILITY FOR ANY HARDWARE, SOFTWARE, OR DATA STORED OR USED WITH THE PRODUCT, INCLUDING THE COSTS OF REPAIRING, REPLACING, INTEGRATING, INSTALLING OR RECOVERING SUCH HARDWARE, SOFTWARE, OR DATA.

Any disputes arising between manufacturer and customer shall be governed by the laws of Santa Clara County in the State of California, USA. The State of California, County of Santa Clara shall be the exclusive venue for the resolution of any such disputes. Supermicro's total liability for all claims will not exceed the price paid for the hardware product.

FCC Statement: This equipment has been tested and found to comply with the limits for a Class A or Class B digital device pursuant to Part 15 of the FCC Rules. These limits are designed to provide reasonable protection against harmful interference when the equipment is operated in industrial environment for Class A device or in residential environment for Class B device. This equipment generates, uses, and can radiate radio frequency energy and, if not installed and used in accordance with the manufacturer's instruction manual, may cause harmful interference with radio communications. Operation of this equipment in a residential area is likely to cause harmful interference, in which case you will be required to correct the interference at your own expense.

California Best Management Practices Regulations for Perchlorate Materials: This Perchlorate warning applies only to products containing CR (Manganese Dioxide) Lithium coin cells. "Perchlorate Material-special handling may apply. See [www.dtsc.ca.gov/hazardouswaste/perchlorate](http://www.dtsc.ca.gov/hazardouswaste/perchlorate)".



WARNING: This product can expose you to chemicals including lead, known to the State of California to cause cancer and birth defects or other reproductive harm. For more information, go to [www.P65Warnings.ca.gov](http://www.P65Warnings.ca.gov).

The products sold by Supermicro are not intended for and will not be used in life support systems, medical equipment, nuclear facilities or systems, aircraft, aircraft devices, aircraft/emergency communication devices or other critical systems whose failure to perform be reasonably expected to result in significant injury or loss of life or catastrophic property damage. Accordingly, Supermicro disclaims any and all liability, and should buyer use or sell such products for use in such ultra-hazardous applications, it does so entirely at its own risk. Furthermore, buyer agrees to fully indemnify, defend and hold Supermicro harmless for and against any and all claims, demands, actions, litigation, and proceedings of any kind arising out of or related to such ultra-hazardous use or sale.

Manual Revision 1.0

Release Date: December 09, 2024

Unless you request and receive written permission from Super Micro Computer, Inc., you may not copy any part of this document. Information in this document is subject to change without notice. Other products and companies referred to herein are trademarks or registered trademarks of their respective companies or mark holders.

Copyright © 2024 by Super Micro Computer, Inc.  
All rights reserved.

**Printed in the United States of America**

# Preface

## About this Manual

This manual is written for professional system integrators and PC technicians. It provides information for the installation and use of the server. Installation and maintenance should be performed by certified service technicians only.

Please refer to the ARS-221GL-SR server specifications page on our website for updates on supported memory, processors, and operating systems (<http://www.supermicro.com>).

## Notes

For your system to work properly, please follow the links below to download all necessary drivers/utilities and the user's manual for your server.

- Supermicro product manuals: <http://www.supermicro.com/support/manuals/>
- Product drivers and utilities: <https://www.supermicro.com/wdl>
- Product safety info: [http://www.supermicro.com/about/policies/safety\\_information.cfm](http://www.supermicro.com/about/policies/safety_information.cfm)

If you have any questions, please contact our support team at: [support@supermicro.com](mailto:support@supermicro.com)

This manual may be periodically updated without notice. Please check the Supermicro website for possible updates to the manual revision level.

## Secure Data Deletion

A secure data deletion tool designed to fully erase all data from storage devices can be found on our website: [https://www.supermicro.com/about/policies/disclaimer.cfm?url=/wdl/utility/Log9\\_Secure\\_Data\\_Deletion\\_Utility/](https://www.supermicro.com/about/policies/disclaimer.cfm?url=/wdl/utility/Log9_Secure_Data_Deletion_Utility/)

## Warnings

Special attention should be given to the following symbols used in this manual.



**Warning!** Indicates important information given to prevent equipment/property damage or personal injury.



**Warning!** Indicates high voltage may be encountered when performing a procedure.

# Contents

Contacting Supermicro.....	7
<b>Chapter 1 Introduction</b>	
1.1 Overview.....	8
1.2 System Features .....	9
Front View .....	9
Power Supply Status Indicators .....	10
Drive Carrier Indicators.....	10
Control Panel.....	11
Rear View.....	12
Input/Output Panel.....	13
Top View.....	14
1.3 Motherboard Layout .....	15
Quick Reference Table.....	16
Grace CPU Superchip.....	17
Motherboard Block Diagram .....	18
<b>Chapter 2 Server Installation</b>	
2.1 Unpacking the System .....	19
2.2 Preparing for Setup.....	19
Choosing a Setup Location.....	19
Rack Precautions .....	19
Server Precautions.....	20
Rack Mounting Considerations .....	20
Ambient Operating Temperature.....	20
Airflow .....	20
Mechanical Loading.....	20
Circuit Overloading .....	21
Reliable Ground.....	21
Particulate and Gaseous Contamination Limits.....	22
Particulate Contamination Specifications .....	22
Gaseous Contamination Specifications.....	22

2.3	Installing the System into a Rack.....	23
	Separating the Sections of the Rack Rails.....	23
	Releasing the Inner Rail.....	24
	Installing the Inner Rails on the Chassis .....	25
	Installing the Outer Rails on the Rack.....	26
	Installing into the Rack.....	27
	Removing the Chassis from the Rack .....	28
	Removing the Outer Rails from the Rack.....	29
<b><i>Chapter 3 Maintenance and Component Installation</i></b>		
3.1	Removing Power .....	30
3.2	Accessing the System.....	31
3.3	Processor and Heatsink Installation.....	32
3.4	Memory.....	36
3.5	Motherboard Battery.....	37
3.6	Storage Drives.....	38
	Module Carrier .....	38
	Checking the Temperature of an NVMe Drive.....	39
	Hot-Swap for NVMe Drives.....	40
3.7	System Cooling .....	41
	Fans .....	41
3.8	Power Supply .....	42
	Power Supply LEDs.....	42
3.9	Installing PCIe Cards/GPU.....	44
<b><i>Chapter 4 Motherboard Connections</i></b>		
4.1	Power Connections .....	45
4.2	Headers and Connectors .....	47
	Front Control Panel.....	48
	Front Control Panel Pin Definitions.....	49
4.3	LED Indicators.....	51
4.4	M.2 Solid State Drive Installation.....	53
<b><i>Chapter 5 Software</i></b>		
5.1	Ubuntu® Server 22.04 ISO Installation.....	54
5.2	IPMI .....	69
5.3	BMC.....	69

---

---

**Chapter 6 Optional Components**

6.1 Power Supply Modules .....	70
6.2 TPM Security Module .....	70

**Chapter 7 Troubleshooting and Support**

7.1 Information Resources .....	71
Website .....	71
Direct Links for the ARS-221GL-SR System.....	71
Direct Links for General Support and Information .....	71
7.2 Baseboard Management Controller (BMC).....	72
7.3 Crash Dump Using the BMC Dashboard.....	73
7.4 CMOS Clear .....	74
7.5 BMC Reset .....	74
7.6 Where to Get Replacement Components .....	75
7.7 Reporting an Issue .....	75
Technical Support Procedures .....	75
Returning Merchandise for Service.....	76
Vendor Support Filing System .....	76
7.8 Feedback.....	76
7.9 Contacting Supermicro .....	77

**Appendix A Standardized Warning Statements for AC Systems****Appendix B System Specifications**

## Contacting Supermicro

### Headquarters

Address: Super Micro Computer, Inc.  
980 Rock Ave.  
San Jose, CA 95131 U.S.A.

Tel: +1 (408) 503-8000

Fax: +1 (408) 503-8008

Email: marketing@supermicro.com (General Information)  
Sales-USA@supermicro.com (Sales Inquiries)  
Government\_Sales-USA@supermicro.com (Gov. Sales Inquiries)  
support@supermicro.com (Technical Support)  
RMA@supermicro.com (RMA Support)  
Webmaster@supermicro.com (Webmaster)

Website: [www.supermicro.com](http://www.supermicro.com)

### Europe

Address: Super Micro Computer B.V.  
Het Sterrenbeeld 28, 5215 ML  
's-Hertogenbosch, The Netherlands

Tel: +31 (0) 73-6400390

Fax: +31 (0) 73-6416525

Email: Sales\_Europe@supermicro.com (Sales Inquiries)  
Support\_Europe@supermicro.com (Technical Support)  
RMA\_Europe@supermicro.com (RMA Support)

Website: [www.supermicro.nl](http://www.supermicro.nl)

### Asia-Pacific

Address: Super Micro Computer, Inc.  
3F, No. 150, Jian 1st Rd.  
Zhonghe Dist., New Taipei City 235  
Taiwan (R.O.C)

Tel: +886-(2) 8226-3990

Fax: +886-(2) 8226-3992

Email: Sales-Asia@supermicro.com.tw (Sales Inquiries)  
Support@supermicro.com.tw (Technical Support)  
RMA@supermicro.com.tw (RMA Support)

Website: [www.supermicro.com.tw](http://www.supermicro.com.tw)

# Chapter 1

## Introduction

### 1.1 Overview

This chapter provides an outline of the functions and features of the SuperServer ARS-221GL-SR. The following provides an overview of the specifications and capabilities of the system.

System Overview	
<b>Motherboard</b>	G1SMH
<b>Chassis</b>	CSE-GP201TS
<b>Processors</b>	Nvidia Grace™ CPU Superchip via four Mirror Mezz connectors
<b>Memory</b>	Embedded 240/480/960 GB ECC LPDDR5 with up to 1 TB/s throughput
<b>Chipset</b>	On-chip
<b>GPUs</b>	NVIDIA® PCIe GPUs: H100, H100 NVL, L40S
<b>Storage</b>	Eight E1.S hot-swap NVMe storage drives (Four are default from One Bluefield-3, additional four are optional with extra One Bluefield-3.) Two M.2 NVMe SSDs (strongly recommended for OS boot drive only)
<b>Expansion Slots</b>	Seven PCIe 5.0 x16 slots (Four FHFL double-width for GPU bays & three FHFL single-width for IO bays)
<b>I/O Bays</b>	One 1 GbE RJ45 dedicated BMC LAN port Two USB3.0 ports One Mini DisplayPort
<b>System Cooling</b>	Six heavy-duty counter-rotating fans with optimal fan speed control
<b>Power</b>	Three redundant (2+1) 2000 W power supplies, 80Plus Titanium level
<b>Form Factor</b>	2U rackmount; 17.25" (W) x 3.46" (H) x 35.43" (D) (438.4 x 88 x 900 mm)

**Notes:** A Quick Reference Guide can be found on the [product page](#) of the Supermicro website. The following safety models associated with the ARS-221GL-SR have been certified as compliant with UL and CSA: GP201-R20X13.

## 1.2 System Features

The following views of the system display the main features. Refer to [Appendix B](#) for additional specifications.

### Front View

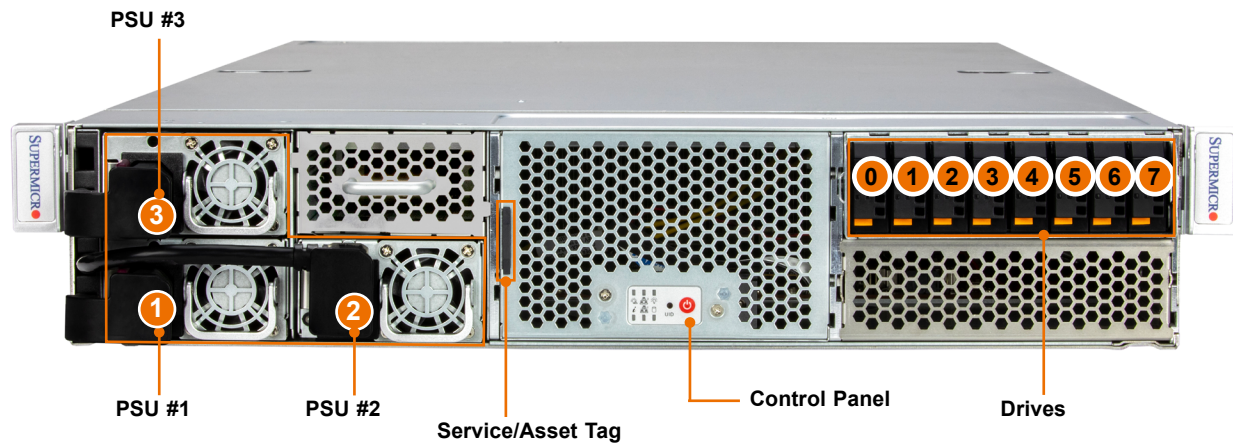

Figure 1-1. Front View (Default Configuration)

System Features: Front	
Feature	Description
Power Supplies	Three redundant (2+1) 2000 W power supplies, 80Plus Titanium level (see Power Supply Status Indicator on next page)
Control Panel	One control panel (see <a href="#">Control Panel</a> for details)
Service Tag	Service Tag with <a href="#">BMC Password Reset</a>

Logical Storage Drive Numbers	
Item	Description
0 to 7	Eight E1.S hot-swap NVMe SSDs (Solid-state drives), 9.5 mm or 15 mm

### *Power Supply Status Indicators*

Power Supply Status Indicators	
LED Color and State	Power Supply Condition
Solid Green	Indicates that the power supply is on
Blinking Green	Indicates that the power supply is plugged in and turned off by the system.
Blinking Amber	Indicates that the power supply has a warning condition and continues to operate.
Solid Amber	Indicates that the power supply is plugged in, and is in an abnormal state. The system might need service. Please contact Supermicro technical support.
Off	No AC power to modules

### *Drive Carrier Indicators*

Each E.1 SSD has two LED indicators: an activity indicator and a status indicator.

Drive Carrier LED Indicators			
	Color	Blinking Pattern	Behavior for Device
<b>Activity LED</b>	Green	Solid On	Idle
	Green	Blinking	I/O activity
	Off		Eject device
<b>Status LED</b>	Off		Idle
	Amber	Blinking at 4 Hz	Locate device
	Amber	Blinking at 1 Hz for a few seconds, then off	Eject device or insert device, as appropriate

**Note:** The normal behavior of the E1.s SSD relies on using Bluefield-3 firmware (FW version 32.43.1014) in combination with AOM-GP101-IPMI-P CPLD firmware 0D.

## Control Panel

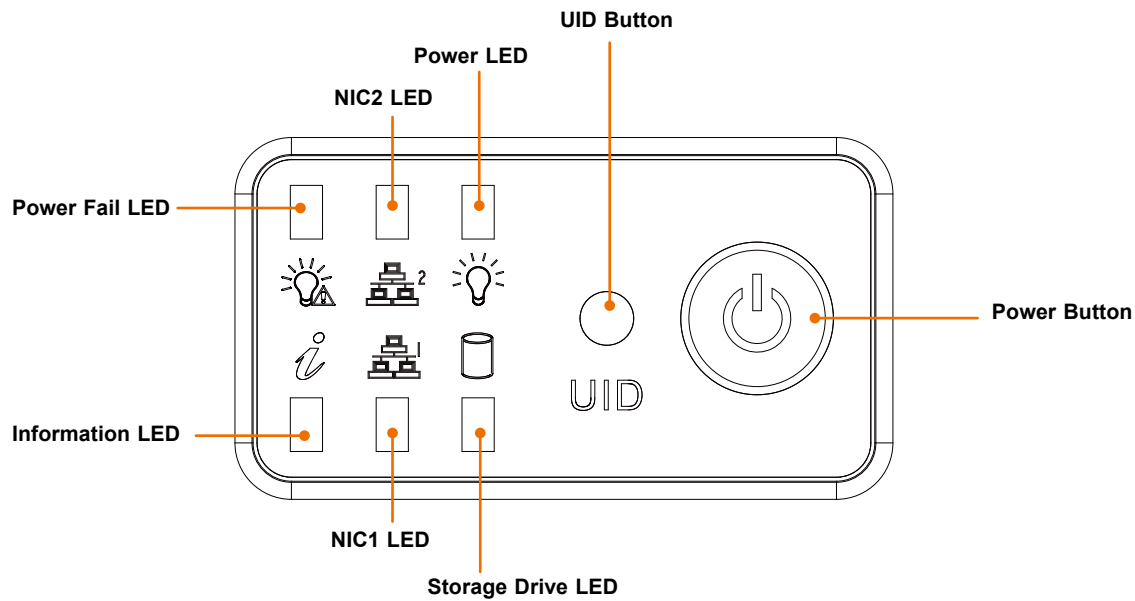

Figure 1-2. Control Panel

Control Panel Features	
Features	Description
Power Button	The main power switch applies or removes primary power from the power supply to the server but maintains standby power.
UID Button	The unit identification (UID) button turns on or off the blue light function of the Information LED and a blue LED on the rear of the chassis. This button can also be used to <a href="#">reset the BMC</a> .
Power LED	Steady on – Power on Blinking at 4 Hz – Checking BIOS/BMC integrity Blinking at 4 Hz and "i" LED is blue – BIOS firmware updating Two blinks at 4 Hz, one pause 2 Hz and "i" LED blue – BMC firmware updating Blinking at 1 Hz and "i" LED red – Fault detected
Storage Drive LED	Indicates activity on the storage drives when flashing.
NIC LEDs	Indicates network activity on the LAN ports when flashing
Information LED	Alerts operator to several states (noted in the table below).
Power Fail LED	Indicates a power supply module has failed.

Information LED	
Color, Status	Description
Continuously on and red	An overheat condition has occurred. (This may be caused by cable congestion.)
Blinking red (1 Hz)	Fan failure, check for an inoperative fan.
Solid blue	UID has been activated locally to locate the server in a rack environment
Blinking blue (300 msec)	UID has been activated remotely using BMC to locate the server in a rack environment.

## Rear View

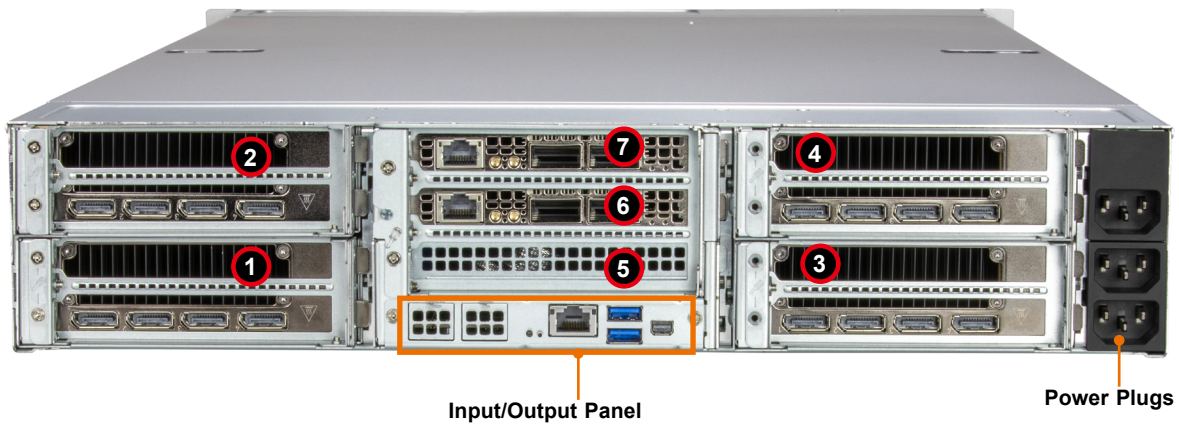

Figure 1-3. System: Rear View

System Features: Rear	
Feature	Description
1 - 4	Four PCIe 5.0 expansion slots for GPUs (FHFL, double-width)
5 - 7	Three PCIe 5.0 expansion slots for I/O bays (FHFL, single-width)
Power Plugs (Female)	The power modules are located in front of the chassis, however the power cables are routed to the rear. These are the plugs that attach to the power cables that plug into the main power source.
Input/Output Panel	See next page for details

## Input/Output Panel

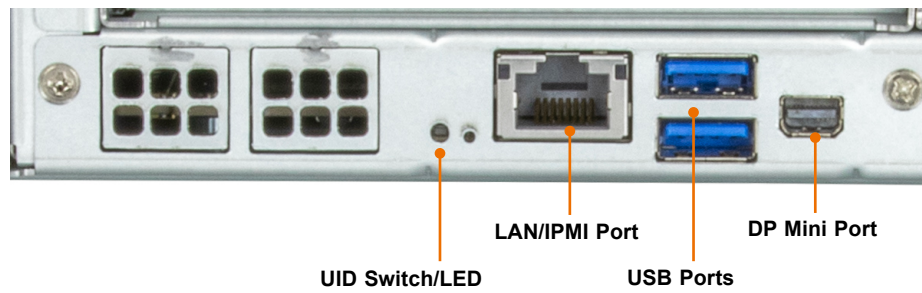
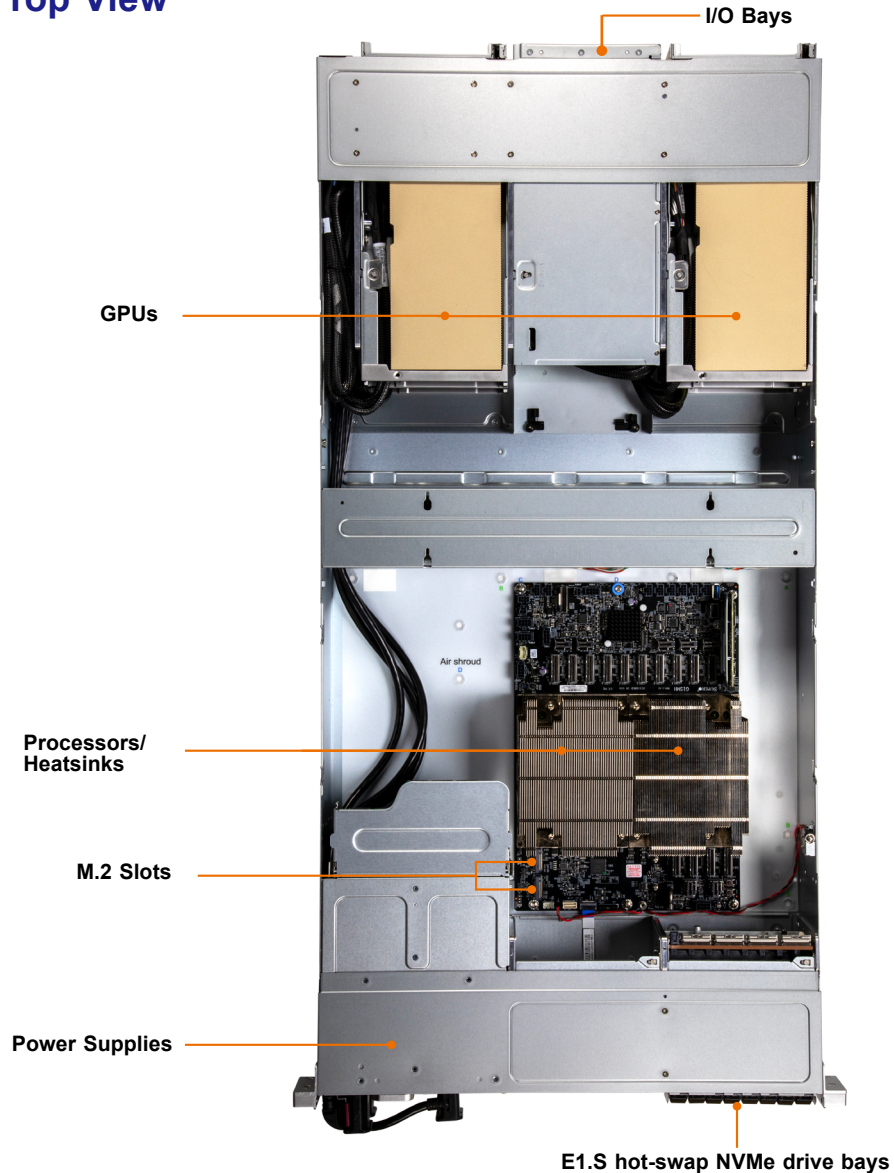

Figure 1-4. Input/Output Panel

Input/Output Panel	
Feature	Description
UID Switch/LED/BMC Button	The unit identification (UID) button turns on or off the blue light function of the Information LED and a blue LED on the rear of the chassis. This button can also be used to <a href="#">reset the BMC</a> .
LAN/IPMI Port	RJ45 port is shared for system network access and BMC access; for indicator details, see <a href="#">BMC LAN LEDs</a>
USB Ports	Two USB 3.0 ports
Mini-DP	One Mini DisplayPort for video output

## Top View



**Figure 1-5. Motherboard Tray: Top View**

System Features: Top	
Feature	Description
GPUs	Slots 1 - 4 provides up to four FHFL double-width GPUs (e.g. H100 NVL, L40S)
I/O Bays	Slots 5 - 7 provides up to three FHFL single-width PCIe 5.0 expansion slots
Processors	Nvidia Grace CPU Superschip via four Mirror Mezz connectors
M.2 Slots	Two Gen5 NVMe x4 M.2 slots in the 22110 form factor
Power Supplies	PWS-2K09F-1R, three 2000 W redundant Titanium level power supplies
NVMe Drives	Eight E1.S hot-swap NVMe drive slots

## 1.3 Motherboard Layout

Below is a layout of the G1SMH motherboard with jumper, connector, and LED locations shown. See the table on the following page for descriptions. For detailed descriptions, pinout information and jumper settings, refer to [Chapter 4](#) or the [Motherboard Manual](#).

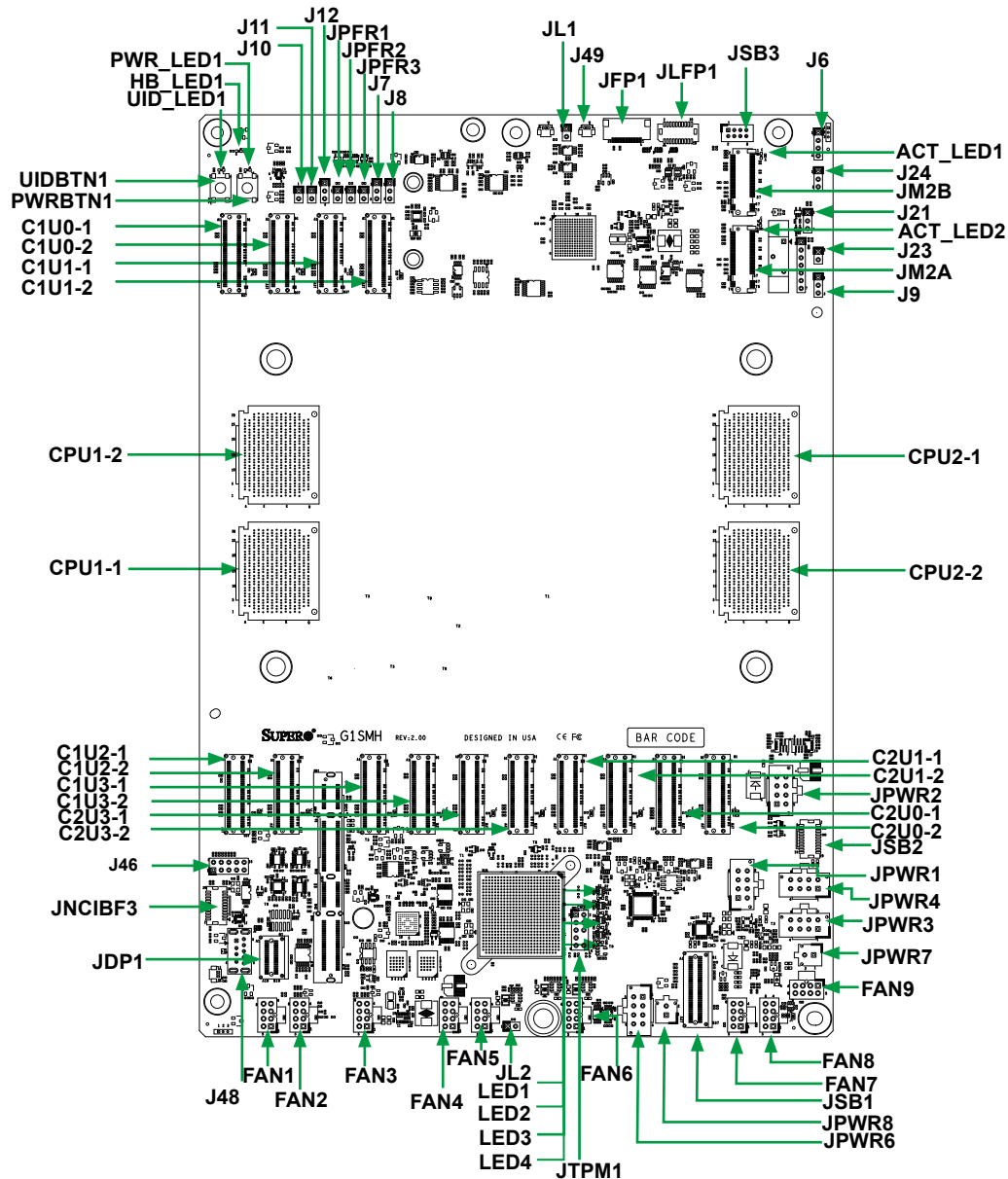

Figure 1-6. Motherboard Layout

### Notes:

- Components not documented are for internal testing only.
- See [Chapter 4](#) for detailed information on jumpers, I/O ports, and JFP1 front panel connections.
- Use only the correct type of onboard CMOS battery as specified by the manufacturer. To avoid a possible explosion, do not install the onboard battery upside down.

## Quick Reference Table

LED	Description	Status
ACT_LED1	M.2 Activity	Green Blinking: M.2 is active
ACT_LED2	M.2 Activity	Green Blinking: M.2 is active
HB_LED1	CPLD Initialization	Green Blinking: CPLD initialized
PWR_LED1	Motherboard Power	Solid green after pressing PWRBTN1
LED1	EROT Detected	Yellow Solid: EROT is detected
LED2	EROT Not Detected	Red Solid: EROT is not detected
LED3	Normal Power Detected	Before pressing PWRBTN1: Green Blinking After pressing PWRBTN1: Green Solid
LED4	Standby Power Detected	Before pressing PWRBTN1: Orange Solid After pressing PWRBTN1: Orange Off
UID_LED1	UID Activity	Blinks blue after pressing UIDBTN1
Connector	Description	
BT1	Onboard Battery	
CPU1-1, CPU1-2	CPU1 Mirror Mezz Connectors	
CPU2-1, CPU2-2	CPU2 Mirror Mezz Connectors	
FAN1-FAN9	System Cooling Fans	
J48	Debug Dongle Only	
JFP1	Front Control Panel Header	
JL1	Chassis Intrusion Header	
JM2A/JM2B	M.2 PCIe Interfaces	
JSB1	IPMI Board Sideband Signal SlimSAS Connector	
JSB2	Power Supply SMBus I2C Header	
JPWR1-JPWR5	12 V 8-pin CPU Core Power Supply Connector	
JPWR6	AOM-GP101-IPMI Power Connector	
JPWR7-JPWR8	2-pin power connectors for standby power	
JTPM1	TPM (Trusted Platform Module)/Port 80	
PWRBINT1	Power Button	
UIDBTN1	UID Button	

**Note:** Jumpers, connectors, switches, and LED indicators that are not described in the preceding tables are for manufacturing testing purposes only, and are not covered in this manual.

## Grace CPU Superchip

- Two Grace chips with attached LPDDR5x memory on a mezzanine module
- 900 GB/s NVLink Chip-to-Chip on the module
- No off-the-module NVLink support

Grace CPU Superchip Overview	
<b>Core Count</b>	144 Arm Neoverse V2 Cores with 4 x128b SVE2
<b>L1 Cache</b>	64 KB i-cache + 64 KB d-cache
<b>L2 Cache</b>	1 MB per core
<b>L3 Cache</b>	234 MB
<b>LPDDR5x Size</b>	240 GB, 480 GB, and 960GB on-module memory options
<b>Memory Bandwidth</b>	Up to 1 TB/s
<b>NVIDIA MLink-C2C Bandwidth</b>	900 GB/s
<b>PCIe Links</b>	Up to eight PCIe Gen5 x16 option to bifurcate
<b>Module Thermal Design Power (TDP)</b>	500 W TDP with memory
<b>Form Factor</b>	Superchip module
<b>Thermal Solution</b>	Air cooled or liquid cooled

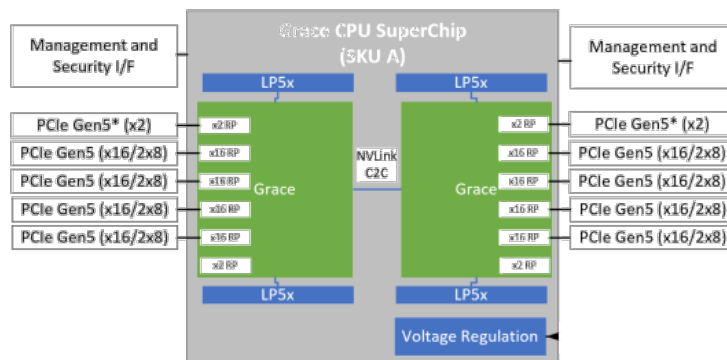



# Chapter 2

## Server Installation

This chapter provides advice and instructions for mounting your system in a server rack. If your system is not already fully integrated with processors, system memory, etc., refer to [Chapter 3](#) for details on installing those specific components.

Read the precautions and considerations noted in this chapter and in [Appendix A](#).

### 2.1 Unpacking the System

Inspect the box in which the system was shipped, and note if it was damaged. If any equipment appears damaged, file a damage claim with the carrier who delivered it.

The box should include the rackmount hardware needed to install the server into the rack.

### 2.2 Preparing for Setup

Please read this section in its entirety before you begin the installation.

#### Choosing a Setup Location

Decide on a suitable location for the rack unit that will hold the server.

- The system requires a grounded AC power outlet nearby.
- It should be a clean, dust-free area that is well ventilated. Avoid areas where heat, electrical noise, and electromagnetic fields are generated.
- Leave enough clearance in front of the rack, approximately 25 inches, to allow the front door to open completely, and approximately 30 inches of clearance in back of the rack to allow sufficient space for airflow and access when servicing.
- This product should be installed only in a Restricted Access Location, such as a dedicated equipment room or service closet.
- This product is not suitable for use with visual display workplace devices according to §2 of the German Ordinance for Work with Visual Display Units.

#### Rack Precautions

- Ensure that the leveling jacks on the bottom of the rack are extended to the floor so that the full weight of the rack rests on them.

- In single rack installations, stabilizers should be attached to the rack. In multiple rack installations, the racks should be coupled together.
- Always make sure the rack is stable before extending a server or other component from the rack.
- You should extend only one server or component at a time - extending two or more simultaneously may cause the rack to become unstable.

## **Server Precautions**

- Review the electrical and general safety precautions in [Appendix A](#).
- Determine the placement of each component in the rack before you install the rails.
- Install the heaviest server components at the bottom of the rack first and then work your way up.
- Use a regulating uninterruptible power supply (UPS) to protect the server from power surges and voltage spikes and to keep your system operating in case of a power failure.
- Allow any drives and power supply modules to cool before touching them.
- When not servicing, always keep the front door of the rack and all covers and panels on the servers closed to maintain proper cooling.

## **Rack Mounting Considerations**

### ***Ambient Operating Temperature***

If installed in a closed or multi-unit rack assembly, the ambient operating temperature of the rack environment may be greater than the room's ambient temperature. Therefore, consideration should be given to installing the equipment in an environment compatible with the manufacturer's maximum rated ambient temperature (TMRA).

### ***Airflow***

Equipment should be mounted into a rack so that the amount of airflow required for safe operation is not compromised.

### ***Mechanical Loading***

Equipment should be mounted into a rack so that a hazardous condition does not arise due to uneven mechanical loading.

### ***Circuit Overloading***

Consideration should be given to the connection of the equipment to the power supply circuitry and the effect that any possible overloading of circuits might have on overcurrent protection and power supply wiring. Appropriate consideration of equipment nameplate ratings should be used when addressing this concern.

### ***Reliable Ground***

A reliable ground must be maintained at all times. To ensure this, the rack itself should be grounded. Particular attention should be given to power supply connections other than the direct connections to the branch circuit (i.e. the use of power strips, etc.).



To prevent bodily injury when mounting or servicing this unit in a rack, you must take special precautions to ensure that the system remains stable. The following guidelines are provided to ensure your safety:

- This unit should be mounted at the bottom of the rack if it is the only unit in the rack.
- When mounting this unit in a partially filled rack, load the rack from the bottom to the top with the heaviest component at the bottom of the rack.
- If the rack is provided with stabilizing devices, install the stabilizers before mounting or servicing the unit in the rack.

## **Particulate and Gaseous Contamination Limits**

Data centers should meet the following requirements to maintain proper air quality.

### ***Particulate Contamination Specifications***

All sources of dust inside data centers should be reduced or eliminated. Dust having a deliquescent relative humidity of less than the maximum allowable relative humidity should be filtered out.

The cleanliness of data centers must adhere to ISO Standard 14644-1 Class 8 (ISO 2015) to be within 95% of the levels specified below:

- Each cubic meter of air should contain no more than 3,520,000 particles that are equal to or greater than 0.5  $\mu\text{m}$  in diameter.
- Each cubic meter of air should contain no more than 832,000 particles that are equal to or greater than 1  $\mu\text{m}$  in diameter.
- Each cubic meter of air should contain no more than 29,300 particles that are equal to or greater than 5  $\mu\text{m}$  in diameter.

This level of cleanliness can generally be achieved by an appropriate filtration scheme, as outlined below:

- The room air should be continuously filtered with MERV 8 filters, as recommended by AHRI Standard 1360 (2017).
- The air entering the data center should be filtered with MERV 11 to MERV 13 filters.

### ***Gaseous Contamination Specifications***

The total gaseous contamination, i.e., copper and silver corrosion rates, should not exceed ANSI/ISA Standard 71.04-2013, severity level G1 (mild) as described below:

- A copper reactivity rate of less than 300  $\text{\AA}/\text{month}$ .
- A silver reactivity rate of less than 200  $\text{\AA}/\text{month}$ .

## 2.3 Installing the System into a Rack

This section provides information on installing the GP201 chassis into a rack unit with the quick-release rails provided. There are a variety of rack units on the market, which may mean the assembly procedure will differ slightly. You should also refer to the installation instructions that came with the rack unit you are using.

**Note:** This rail will fit a rack between 26.5" and 36.4" deep.

### Separating the Sections of the Rack Rails

The chassis package includes two rail assemblies in the rack mounting kit. Each assembly consists of three sections: An inner rail that secures directly to the chassis, an outer rail that secures to the rack, and a middle rail that slides in the outer rail. These assemblies are specifically designed for the left and right side of the chassis.

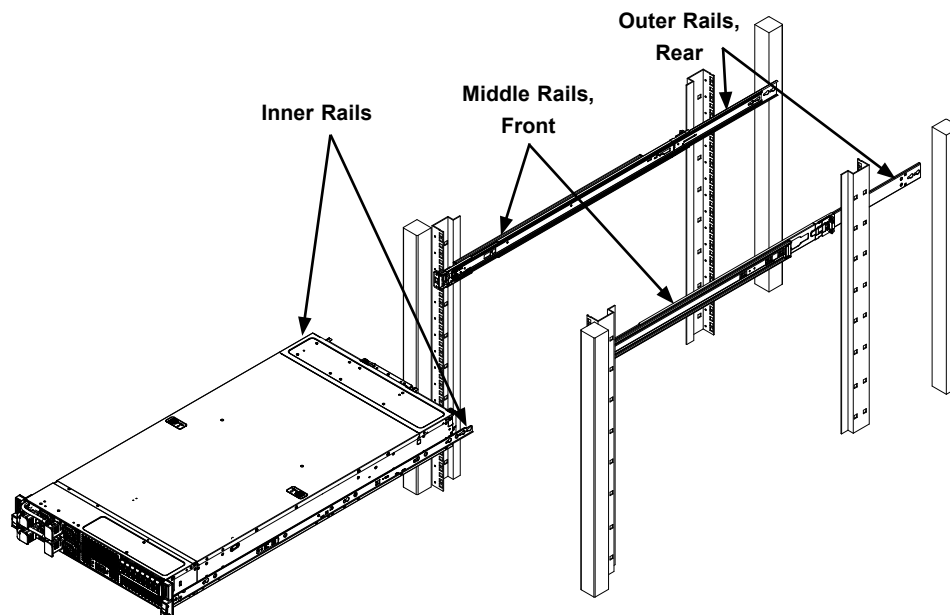

**Figure 2-1. Identifying the Inner Rails, Middle Rails and Outer Rails**

**Note:** Figures are for illustrative purposes only. Your actual chassis may differ. Always install servers into racks from the bottom up.



Slide rail mounted equipment is not to be used as a shelf or a work space.



**Warning:** Do not pick up the server with the front handles. They are designed to pull the system from a rack only.

## Releasing the Inner Rail

It is necessary to release the inner rail from the middle and outer rails before installing the inner rail on the chassis.

### *Releasing the Inner Rail from the Middle and Outer Rails*

1. Lift the front latch on the inner rail and pull the inner rail out of the middle rail, and the middle rail out of the outer rail until the rails are fully extended.
2. Press down the locking lever on the inside of the inner rail to release the inner rail. Continue to pull the inner rail out of the middle rail.

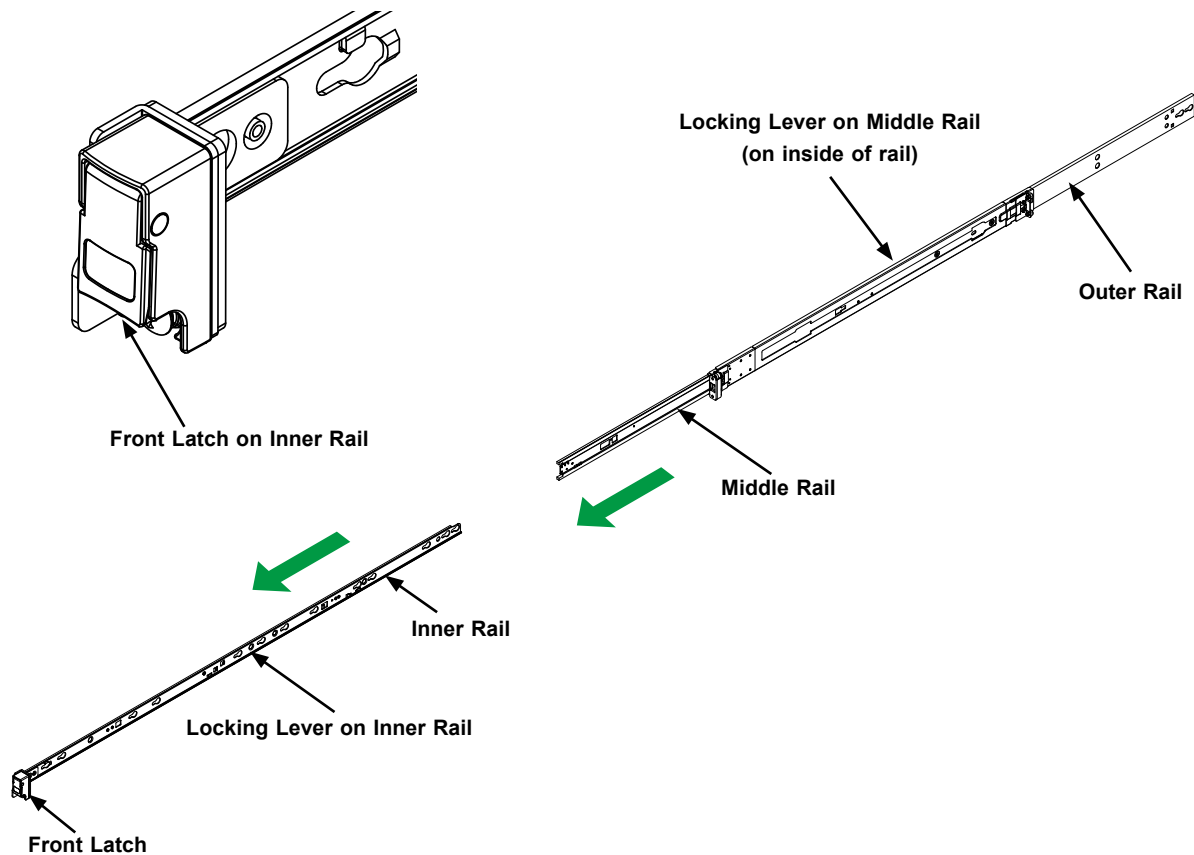

Figure 2-2. Extending the Rails and Releasing the Inner Rail



**Warning:** Stability hazard. The rack stabilizing mechanism must be in place, or the rack must be bolted to the floor before you slide the unit out for servicing. Failure to stabilize the rack can cause the rack to tip over.

## Installing the Inner Rails on the Chassis

### *Installing the Inner Rails*

1. Confirm that the left and right inner rails have been correctly identified.
2. Place the inner rail firmly against the side of the chassis, aligning the pins on the side of the chassis with the slotted thru holes in the inner rail.
3. Slide the inner rail toward the rear of the chassis until the pins are at the end of the narrow slot, which secures the inner rail to the chassis. An optional screw may be added for extra security.
4. Repeat for the other inner rail.

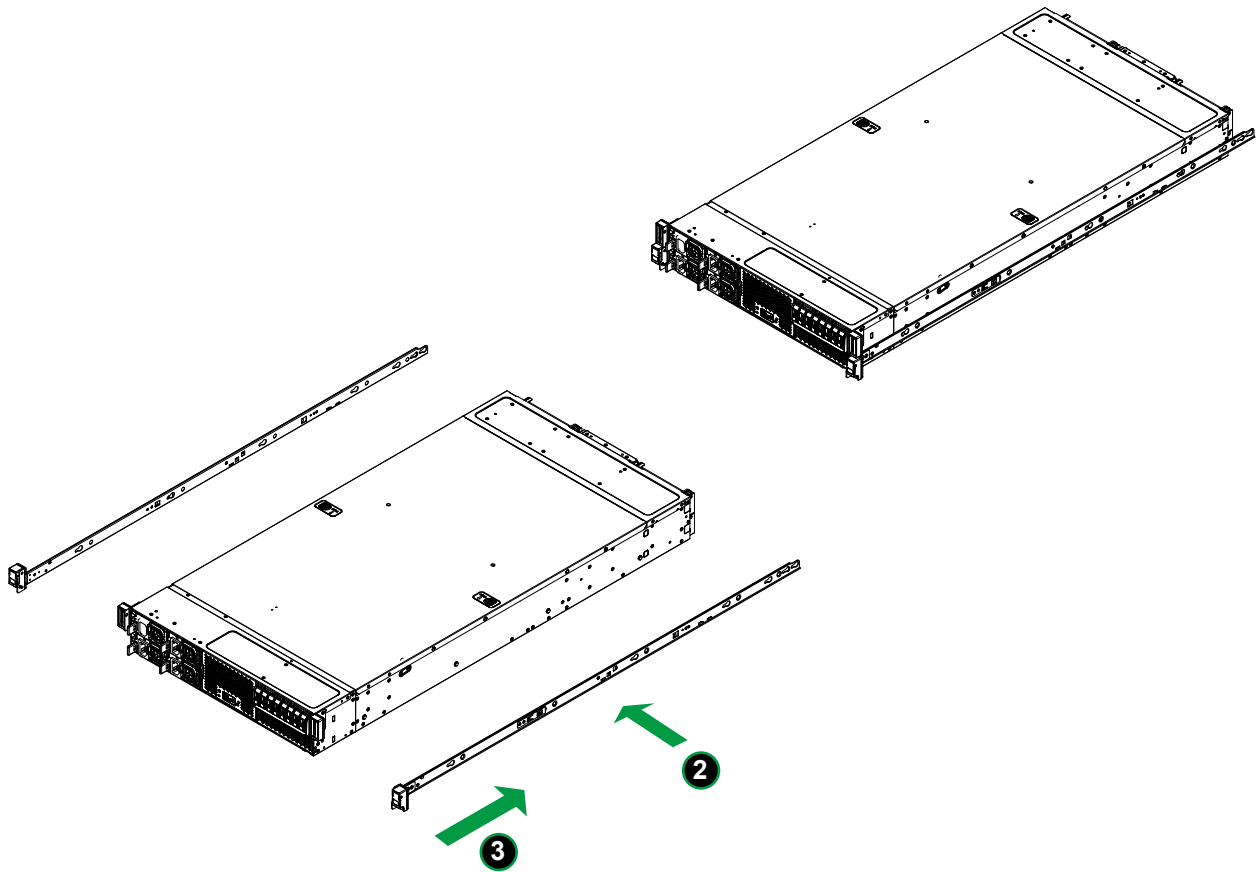
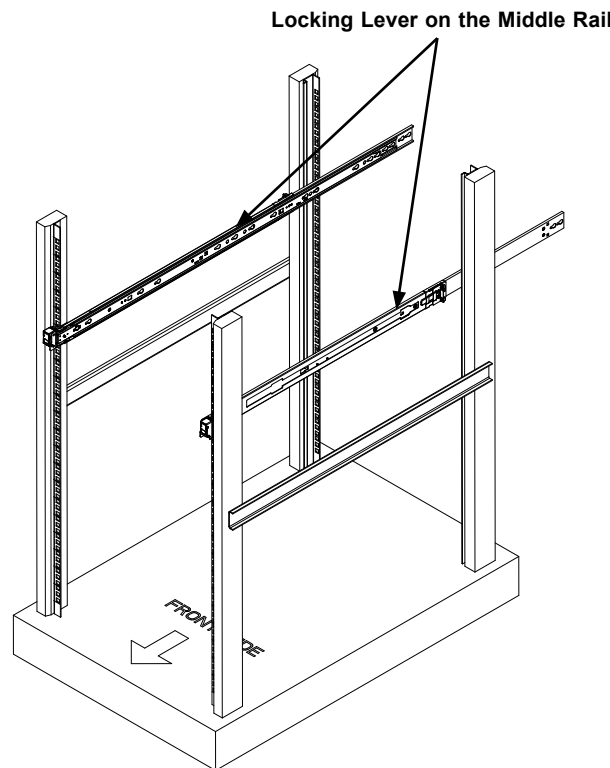

Figure 2-3. Installing the Inner Rails

## Installing the Outer Rails on the Rack

### *Installing the Outer Rails*

1. Confirm that the left and right outer rails have been correctly identified.
2. Release the small locking lever on the inside of the middle rail and push the middle rail back into the outer rail.
3. Insert the pins at the front of the outer rail into the square holes on the front of the rack. Push until the latch snaps into place.
4. The outer rail is actually two pieces that slide to lengthen. Pull out the rear of the outer rail, adjusting the length until the square pin assembly passes, then fits against the back of the rear post. Be careful to keep the rail level.
5. Insert the pins at the rear of the outer rail into the square holes on the rear of the rack. Push until the latch snaps into place.
6. Repeat for the other outer rail.



**Figure 2-4. Installing the Outer Rails**

**Note:** Figures are for illustrative purposes only. Your actual chassis may differ. Always install servers into racks from the bottom up.

## Installing into the Rack

After the rails are installed on the chassis and on the rack, the server can be installed in the rack. It is heavy and requires two to three people to lift.

### *Installing the Chassis into a Rack*

1. Pull both middle rails out the front of the outer rail until each clicks to a stop.
2. Align the inner rails on the chassis with the front of the middle rails.
3. Slide the inner rails on the chassis into the middle rails, keeping the pressure even on both sides. When partially in, the locking levers will stop further progress.
4. Press down the locking levers on the inside of the inner rails and push the chassis all the way into the rear of the rack. The front latches will click into place.

The chassis is now mounted in the rack. It can be pulled partially out for service by lifting both front latches.

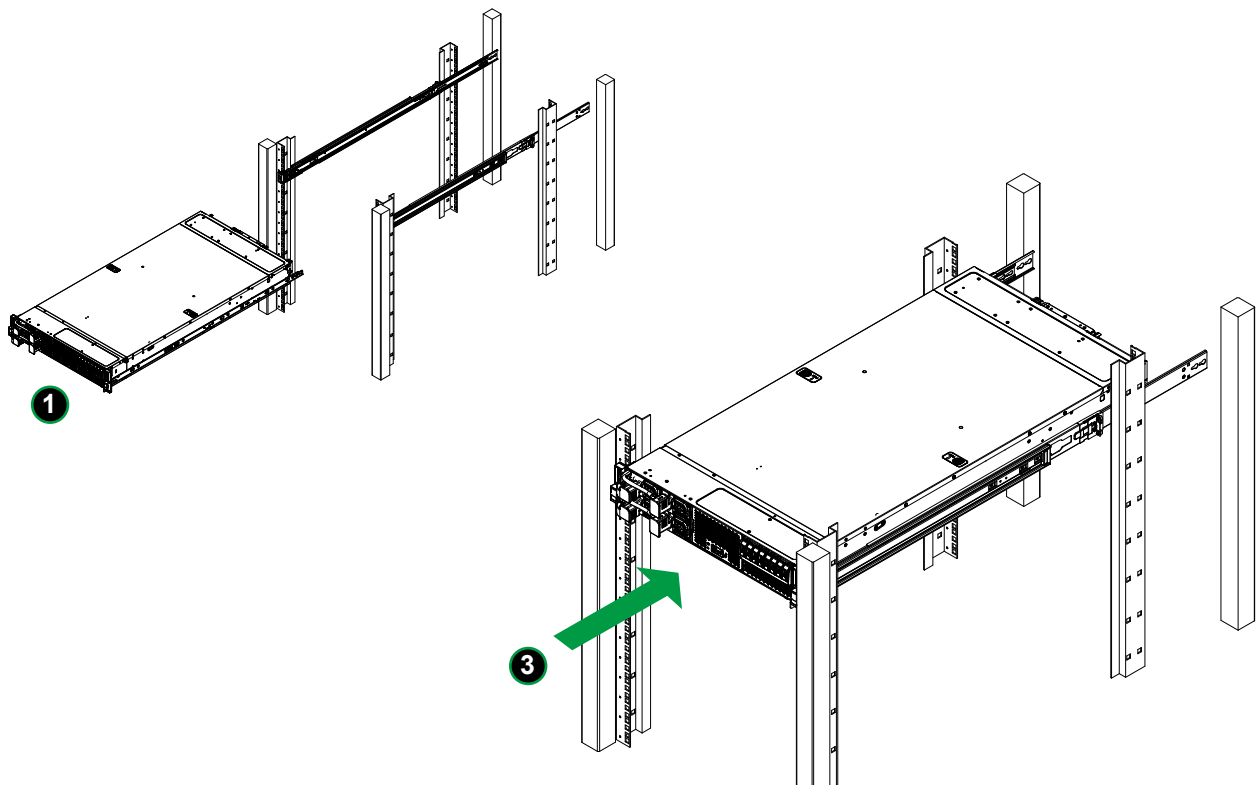

**Figure 2-5. Installing the Chassis into the Rack**

**Note:** Figures are for illustrative purposes only. Your actual chassis may differ. Always install servers into racks from the bottom up.

## Removing the Chassis from the Rack

**Caution:** The chassis is heavy and requires two to three people to lift it out.

### *Removing the Chassis*

1. Lift the right and left front latches which are just below the LED control panels on the front edges of the chassis.
2. Pull the chassis forward until it clicks to a stop.
3. Press down the locking lever on the inside of the inner rail (Figure 2-2) to release the chassis. Continue to pull the chassis out of the middle rails.

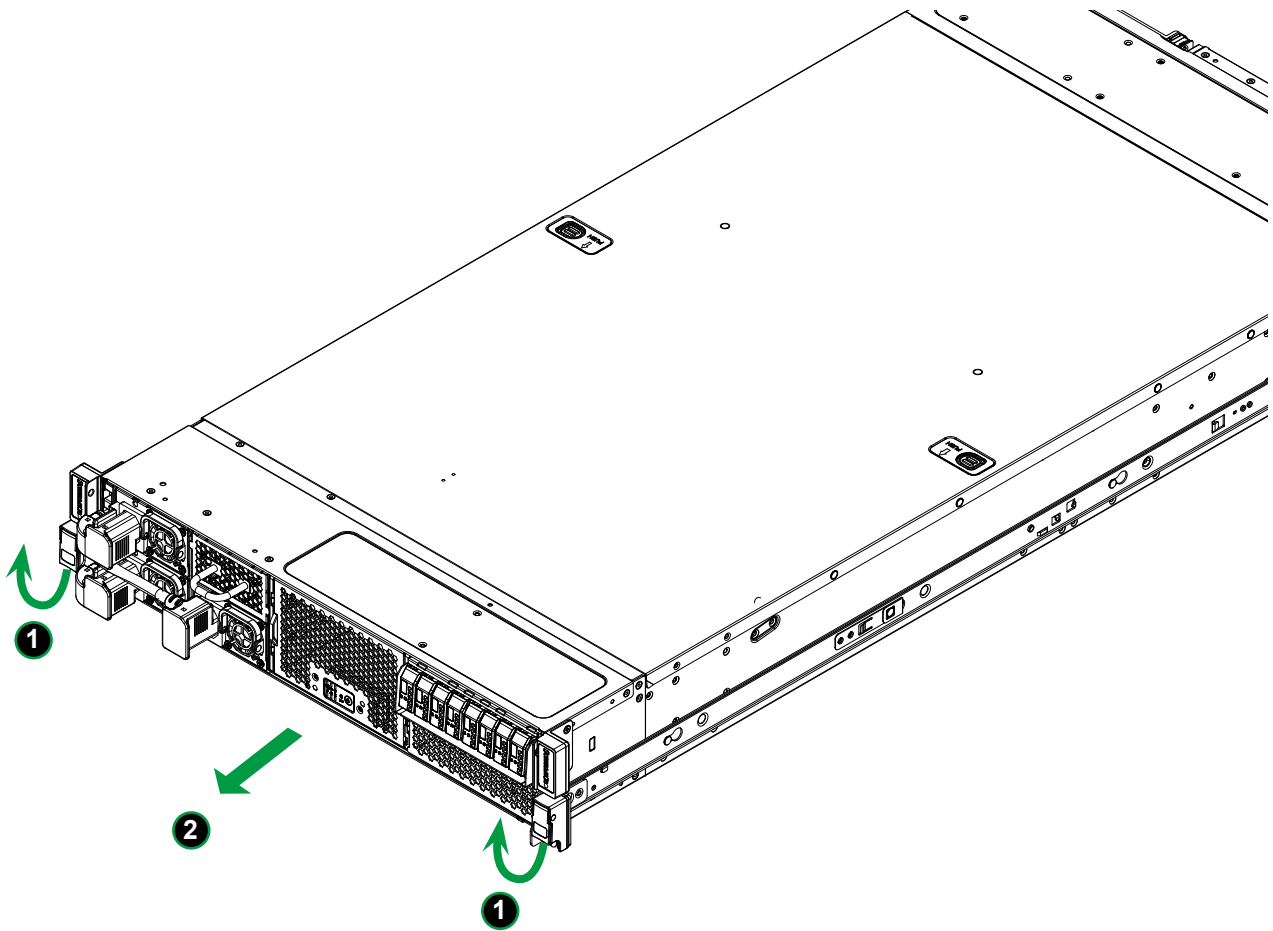

Figure 2-6. Removing the Chassis from the Rack

## Removing the Outer Rails from the Rack

In the uncommon event that it is necessary to remove the outer rails from the rack, follow these instructions. The chassis must be out of the rack.

### *Releasing the Outer Rails*

1. On the front of the outer rail, slide the small plastic safety slider (red in drawing) up and hold it while pushing the plastic release button (green in drawing) just below it.
2. While holding the release button in, pull the outer rail forward to disengage the pins and the front of the rail from the rack.
3. Support the front of the outer and middle rail assembly while releasing the rear.
4. Remove the outer rail from the rear of the rack in the same way as the front. Slide the safety slider up and push and hold the release button, then pull the rear pins out of the rack and remove the rail.

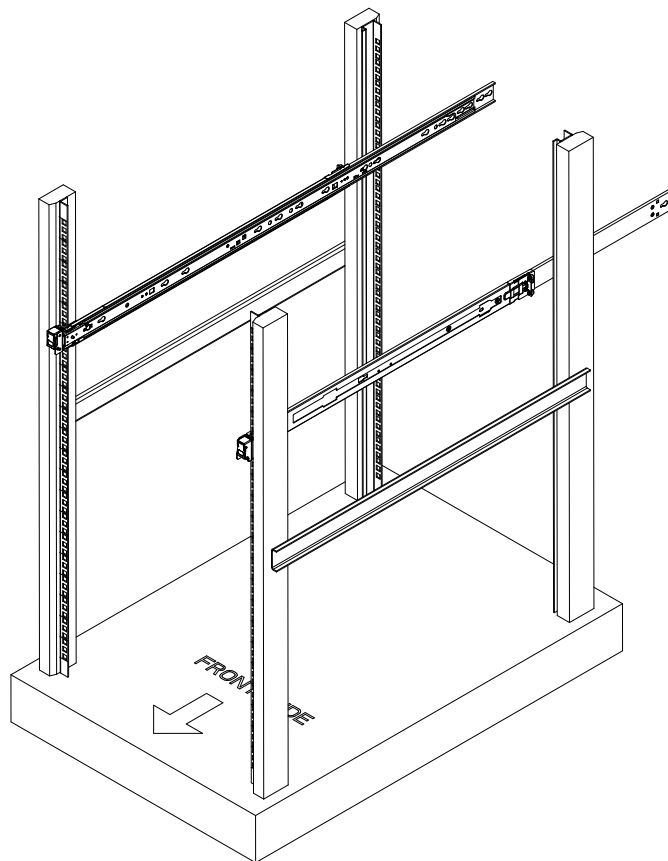

Figure 2-7. Removing the Outer Rails

## Chapter 3

# Maintenance and Component Installation

This chapter provides instructions on installing and replacing main system components. To prevent compatibility issues, only use components that match the specifications and/or part numbers given.

Installation or replacement of most components require that power first be removed from the system. Please follow the procedures given in each section.

**Caution:** Electrostatic Discharge (ESD) can damage electronic components. To prevent such damage to printed circuit boards (PCBs), it is important to use a grounded wrist strap, handle all PCBs by their edges and keep them in anti-static bags when not in use.

### 3.1 Removing Power

Use the following procedure to ensure that power has been removed from the system. This step is necessary when removing or installing non hot-swap components or when replacing a non-redundant power supply.

1. Use the operating system to power down the system.
2. After the system has completely shut-down, disconnect the AC power cord(s) from the power strip or outlet. (If your system has more than one power supply, remove the AC power cords from all power supply modules.)
3. Disconnect the power cord(s) from the power supply module(s).

## 3.2 Accessing the System

The chassis features a removable top cover for access to the internal components. When performing service on components inside the system, remove the system from the rack and place it on a work bench or desk. Do not service with the system extended from the rack.

### *Removing the Top Cover*

1. Check whether optional screws are used on the side of the cover. If so, remove them.
2. Press the release buttons and slide the cover toward the front and off.

**Caution:** Except for short periods of time, do not operate the server without the cover in place. The chassis cover must be in place to allow for proper airflow and to prevent overheating.

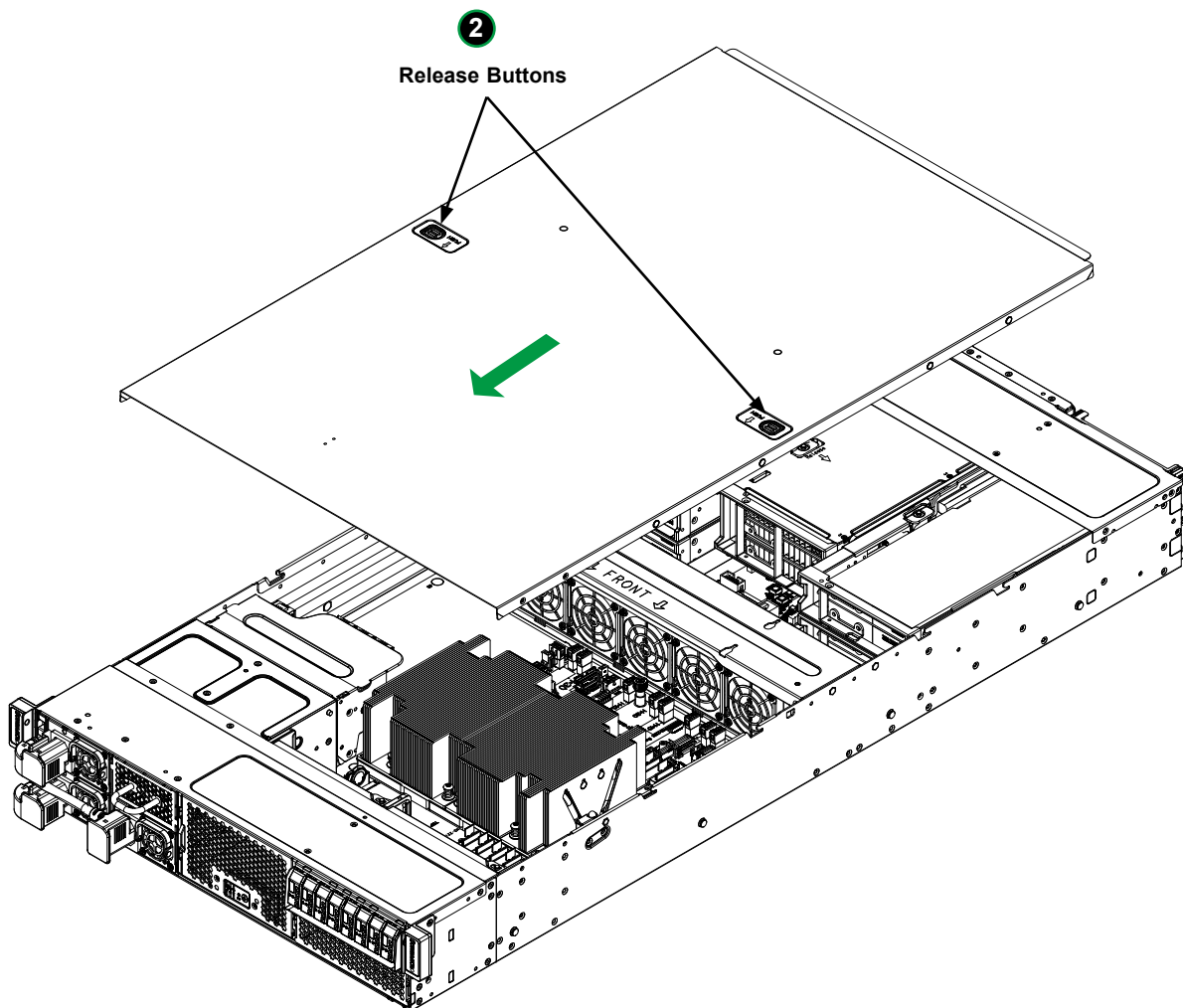

Figure 3-1. Removing the System Cover

### 3.3 Processor and Heatsink Installation

**Important:**

- For the Superchip and heatsink installation you need to use a T20 torque driver.
- Always connect the power cord last, and always remove it before adding, removing or changing any hardware components.
- If you buy a Superchip separately, make sure that you use an NVIDIA-certified multi-directional heatsink only.
- Make sure to install the motherboard into the chassis before you install the heatsink.
- Refer to the Supermicro website for updates on the Superchip support.
- When installing the heatsink, ensure a torque driver set to the correct force is used for each screw.
- Processors and heatsinks must be installed by the manufacturer.

### ***Installing the Superchip onto the Motherboard***

1. Align the Superchip with its guide pins to the holes circled in red on the motherboard.

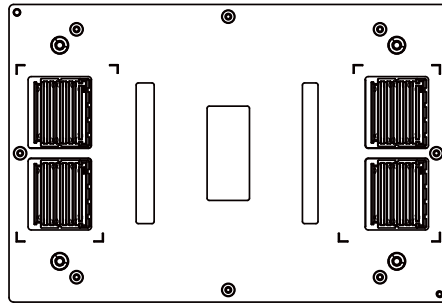

**Superchip Bottom View**

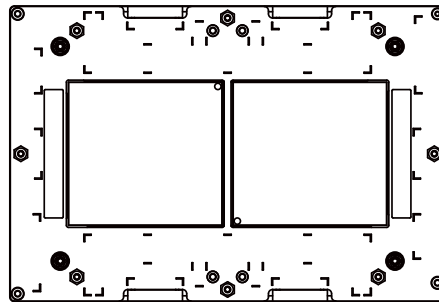

**Superchip Top View**

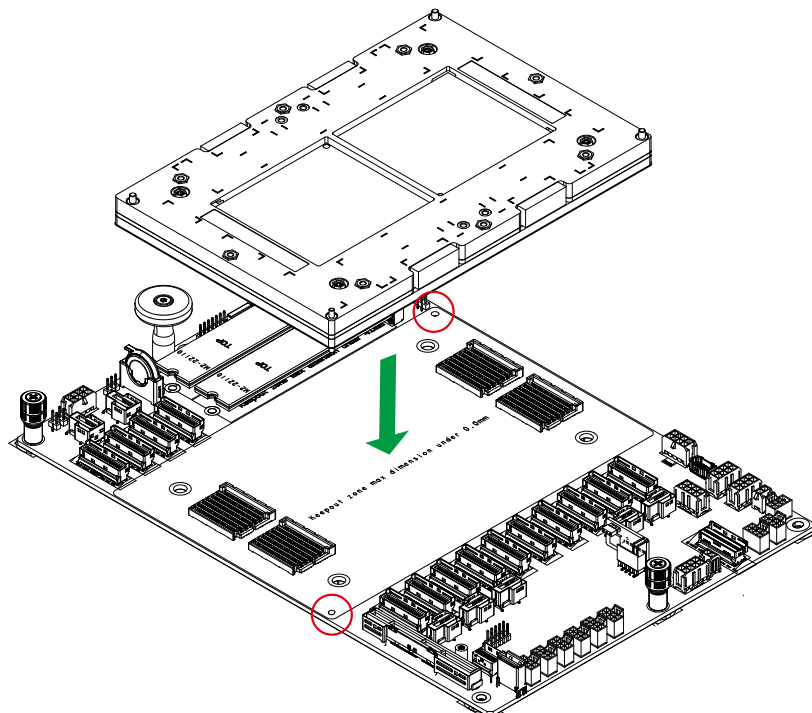

2. Before the springs underneath the Superchip are compressed, check the alignment of the guide pins and the holes on the motherboard again.

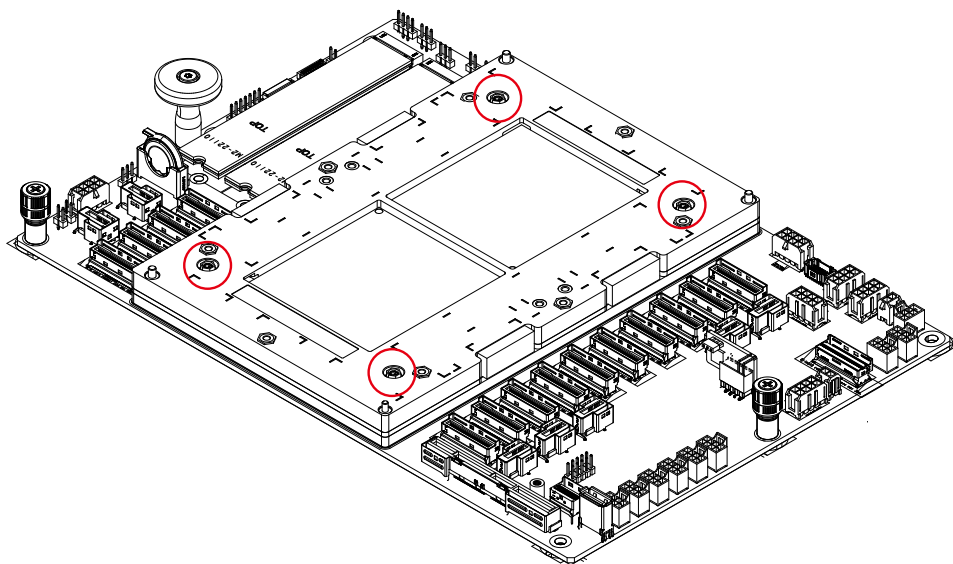

3. Fasten the four screws using a torque of 9.5 +/- 4% in-lbf to complete the Superchip installation.

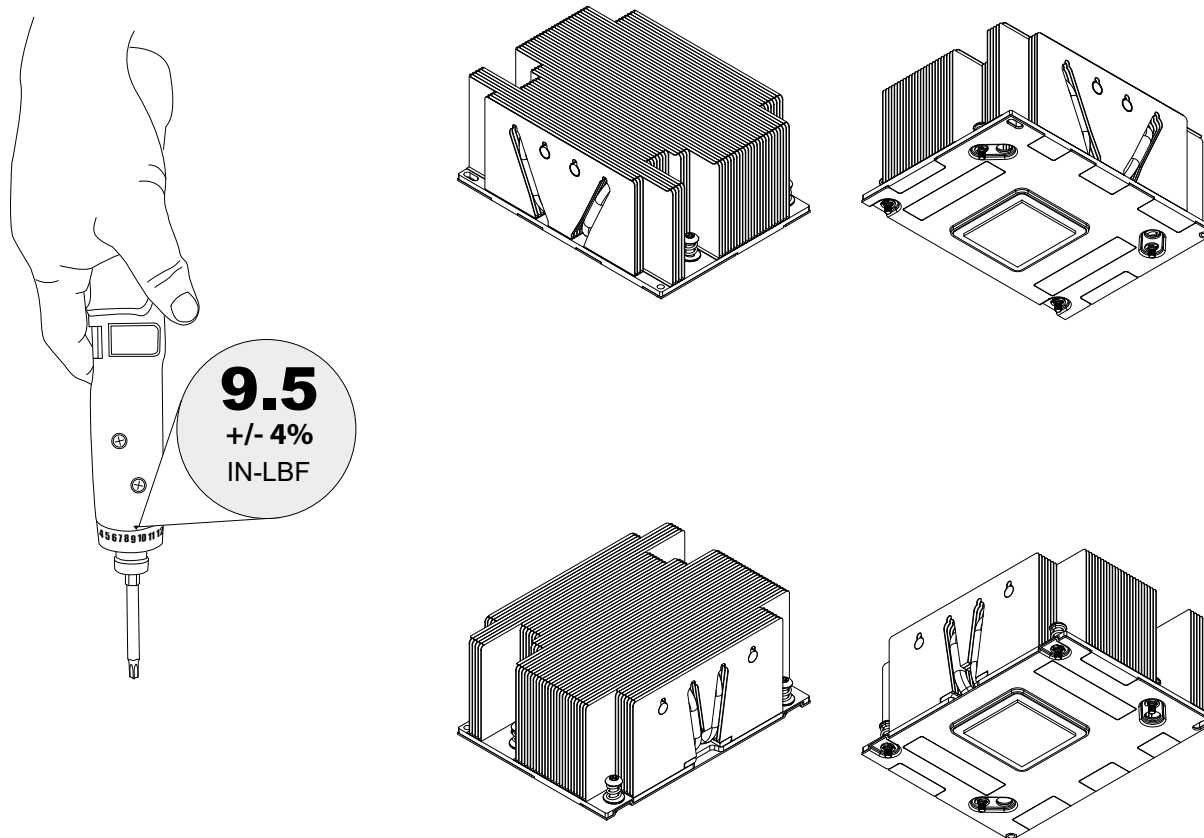

4. Peel off the thermal pad protector underneath each heatsink.

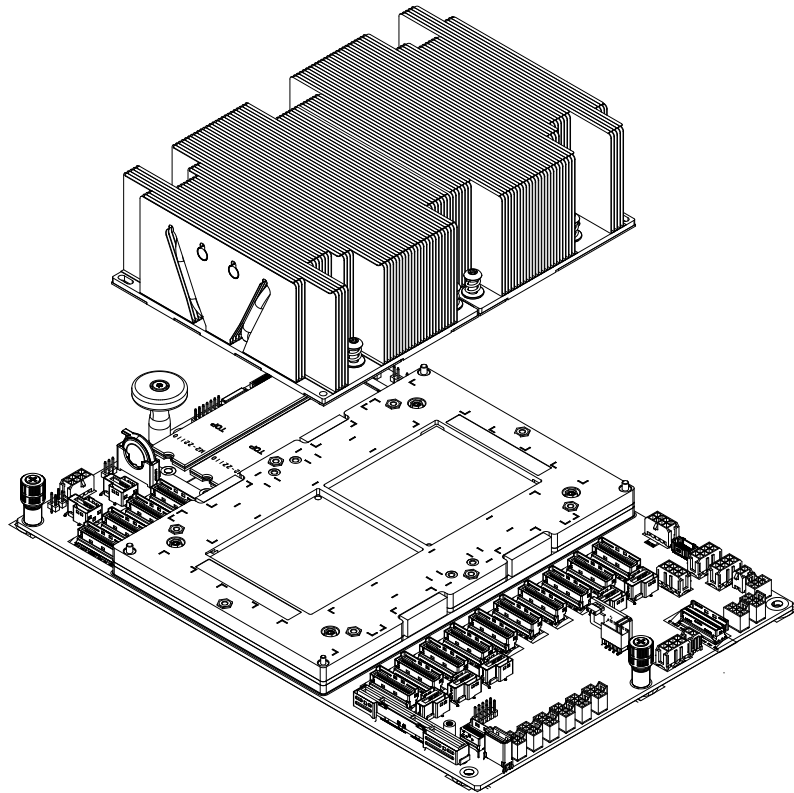

5. Place the heatsinks on top of the Superchip.

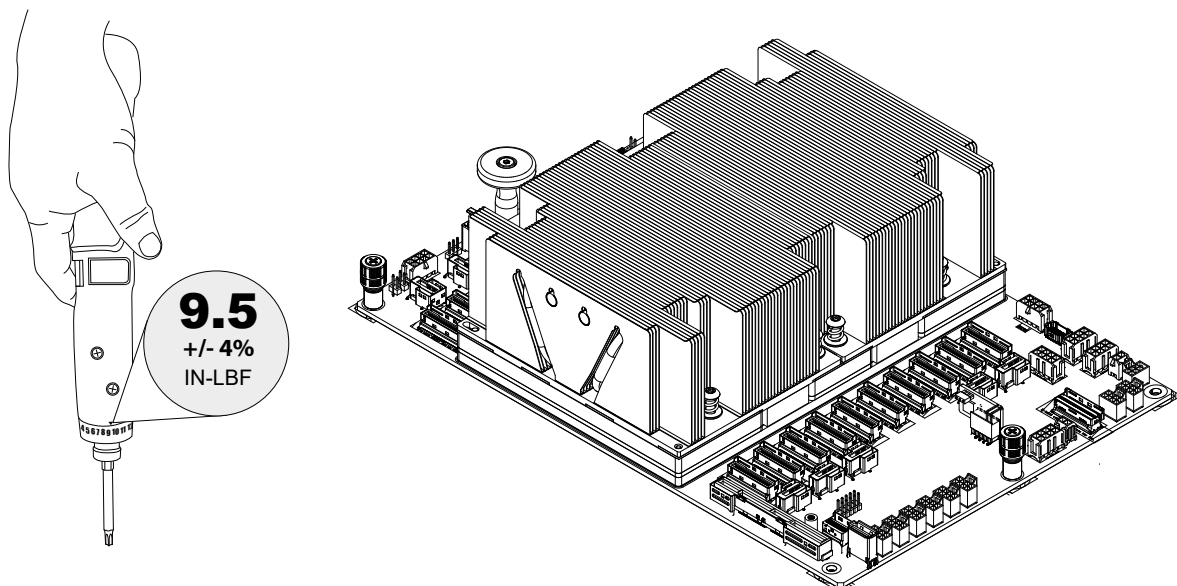

6. Using a torque of 9.5 +/- 4% in-lbf, secure the heatsinks onto the Superchip with four screws.

### ***Un-installing the Superchip and Heatsinks***

1. Remove the heatsinks attached to the top of the Superchip by reversing the installation procedure.
2. Clean the thermal grease left by the heatsink on the Superchip top to limit the risk of it contaminating the Mirror Mezz connectors.
3. Remove the screws from the Superchip.
4. Lift the Superchip off from the motherboard.

## **3.4 Memory**

The G1SMH supports up to 240/480/960 GB of LPDDR5 ECC with 1 TB/s throughput. The memory is embedded on the Superchip and no installation is required.

## 3.5 Motherboard Battery

The motherboard uses non-volatile memory to retain system information when system power is removed. This memory is powered by a lithium battery residing on the motherboard.

### *Replacing the Battery*

Begin by [removing power](#) from the system.

1. Push aside the small clamp that covers the edge of the battery. When the battery is released, lift it out of the holder.
2. To insert a new battery, slide one edge under the lip of the holder with the positive (+) side facing up. Then push the other side down until the clamp snaps over it.

**Note:** Handle used batteries carefully. Do not damage the battery in any way; a damaged battery may release hazardous materials into the environment. Do not discard a used battery in the garbage or a public landfill. Please comply with the regulations set up by your local hazardous waste management agency to dispose of your used battery properly.

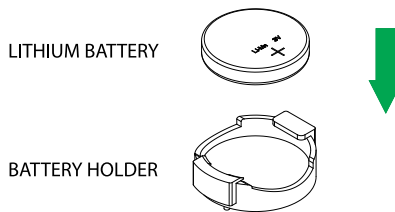

**Figure 3-2. Installing the Onboard Battery**



**CAUTION:** There is a danger of explosion if the onboard battery is installed upside down (which reverses its polarities). This battery must be replaced only with the same or an equivalent type recommended by the manufacturer (BR2032).

## 3.6 Storage Drives

The system supports eight E1.S solid state drives (SSDs) that are 9.5 mm or 15 mm. Eight additional drives can be ordered. Two M.2 SSDs are installed by the manufacturer.

NVMe drives are supported using optional parts that are sold separately. Refer to the optional parts list for more details.

**Note:** Enterprise-level storage modules are recommended for use in Supermicro servers. For compatible storage drives, see the [ARS-221GL-SR](#) product page.

### Module Carrier

The modules are mounted in a carrier to simplify their installation and removal from the chassis. Individual E1.S SSD modules may be removed and installed without removing this carrier, much like a regular hard disk drive. The carrier also helps promote proper airflow through the drive bays. Each E1.S SSD module has two LED indicators. In the event that the carrier needs to be removed from the chassis, please follow the instructions below.

#### *Removing Drive Carriers from the Chassis*

1. To access the E1.S modules, open the chassis cover.
2. Slide the release button located on the side rear of the carrier (see illustration).
3. Pull the carrier out of the chassis.



Figure 3-3. Storage Drive Logical Drive Numbers

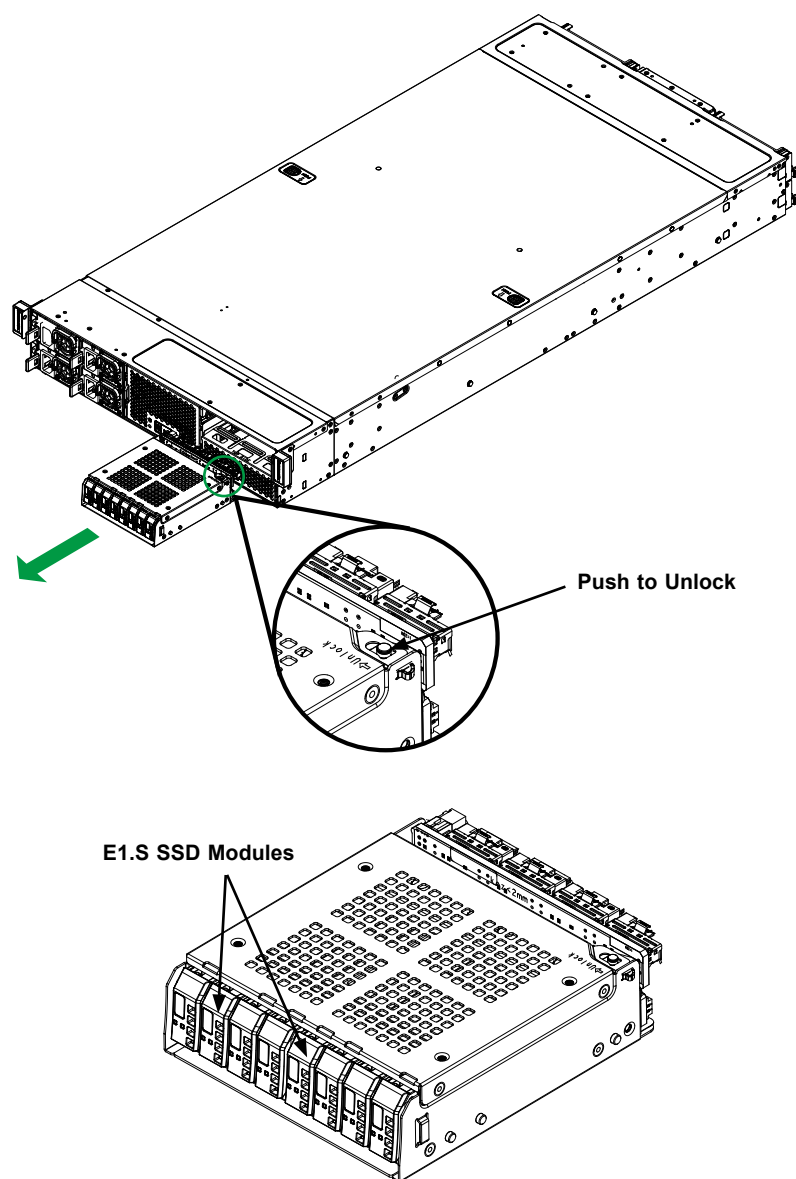

Figure 3-4. E1.S SSD Module Assembly

## Checking the Temperature of an NVMe Drive

There are two ways to check using the BMC Dashboard.

### Checking a Drive

- **BMC Dashboard > Server Health > NVMe SSD** – Shows the temperatures of all NVMe drives.
- **BMC Dashboard > Server Health > Sensor Reading > NVME\_SSD** – Shows the single highest temperature among all the NVMe drives.

## Hot-Swap for NVMe Drives

Supermicro servers support NVMe surprise hot-swap. For even better data security, NVMe orderly hot-swap is recommended. NVMe drives can be ejected and replaced remotely using the BMC Dashboard.

### *Ejecting a Drive*

1. **BMC Dashboard > Server Health > NVMe SSD**
2. Select Device, Group and Slot, and click **Eject**. After ejecting, the drive Status LED indicator turns green.
3. Remove the drive.

Note that Device and Group are categorized by the CPLD design architecture.

Slot is the slot number on which the NVMe drives are mounted.

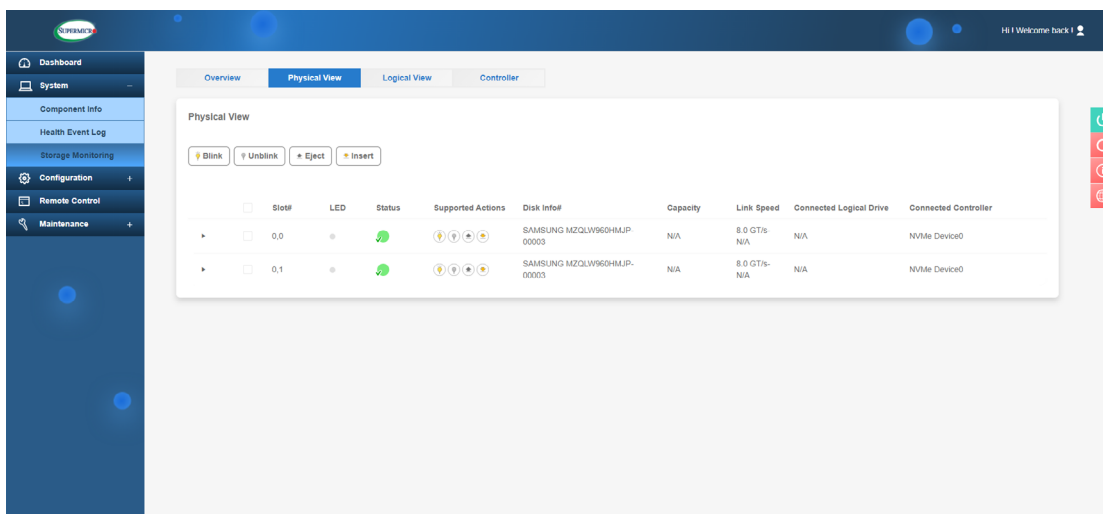

**Figure 3-5. BMC Dashboard Screenshot**

### *Replacing the Drive*

1. Insert the replacement drive.
2. **BMC Dashboard > Server Health > NVMe SSD**
3. Select Device, Group and slot and click **Insert**. The drive Status LED indicator flashes red, then turns off. The Activity LED turns blue.

## 3.7 System Cooling

### Fans

The chassis contains six 60-mm high-performance counter-rotating fans. Fan speed is controlled by the BMC depending on the system temperature. If a fan fails, the remaining fans will ramp up to full speed. The system will continue to run with a failed fan, although it may shut down if the heat gets too great. Replace any failed fan at your earliest convenience with the same model. Failed fans can be identified through the BMC.

**Note:** The fans are not hot-swappable and the system needs to be turned off before replacing.

### Changing a System Fan

1. If necessary, open the chassis while the power is running to determine which fan requires changing. (Never run the server for an extended period of time with the chassis open.)
2. Remove power from the system and unplug the AC power cords from the power supplies.
3. Remove the fan bracket from the top of the fans. Lift the failed fan from the chassis and pull it completely out of the chassis. There are no screws to remove.
4. Place the new fan into the vacant space in the housing while making sure the arrows on the top of the fan (indicating air direction) point in the same direction as the arrows on the other fans.
5. Reconnect the AC power cords and boot up the system. The fan will automatically begin running at the correct speed.

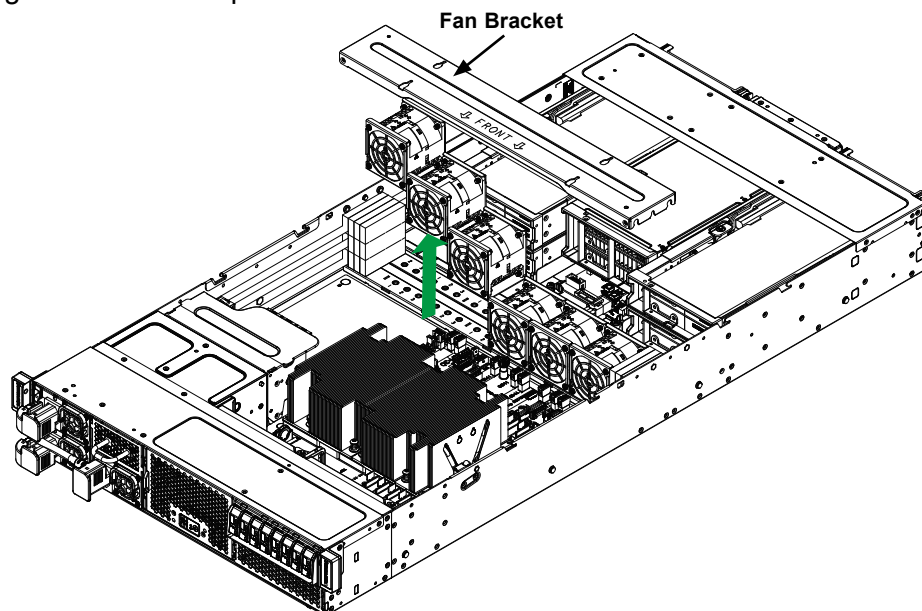

Figure 3-6. Replacing a Fan

## 3.8 Power Supply

The chassis features redundant power supplies. The power modules can be changed without powering down the system. Replace a failed power module with the same model. New units can be ordered directly from Supermicro or authorized distributors.

These power supplies are auto-switching capable. This feature enables them to automatically sense the input voltage and operate at a 100-120 v or 180-240 v.

### Power Supply LEDs

On the front of the power supply module, an LED displays the status.

- **Solid Green:** When illuminated, indicates that the power supply is on.
- **Blinking Green:** When blinking, indicates that the power supply is plugged in and turned off by the system.
- **Blinking Amber:** When blinking, indicates that the power supply has a warning condition and continues to operate.
- **Solid Amber:** When illuminated, indicates that the power supply is plugged in, and is in an abnormal state. The system might need service. Please contact Supermicro technical support.

Power Supply: PWS-2K09F-1R	
2000 W redundant Titanium level power supply	
<b>Dimension</b>	73.5 x 40 x 185 mm (W x H x L)
<b>AC Input</b>	1000 W: 100-127 Vac / 50-60 Hz 1800 W: 200-220 Vac / 50-60 Hz 1980 W: 220-230 Vac / 50-60 Hz 2000 W: 220-240 Vac / 50-60 Hz (for UL only) 2000 W: 230-240 Vac / 50-60 Hz 2000 W: 230-240 Vdc / 50-60 Hz (for CQC only)
<b>+12 V</b>	Max: 83 A / Min: 0 A (100 Vac-127 Vac) Max: 150 A / Min: 0 A (200 Vac-220 Vac) Max: 165 A / Min: 0 A (220 Vac-230 Vac) Max: 166 A / Min: 0 A (230 Vac-240 Vac)
<b>12 VSB</b>	Max: 3.5 A / Min: 0 A
<b>Output Type</b>	Backplanes (gold finger)

### ***Replacing a Power Supply***

1. Unplug the AC cord from the module to be replaced.
2. Push the release tab on the front of the power supply as illustrated.
3. Pull the power supply out using the handle provided.
4. Replace the failed power module with the same model.
5. Push the new power supply module into the power bay until it clicks.
6. Plug the AC power cord back into the module.

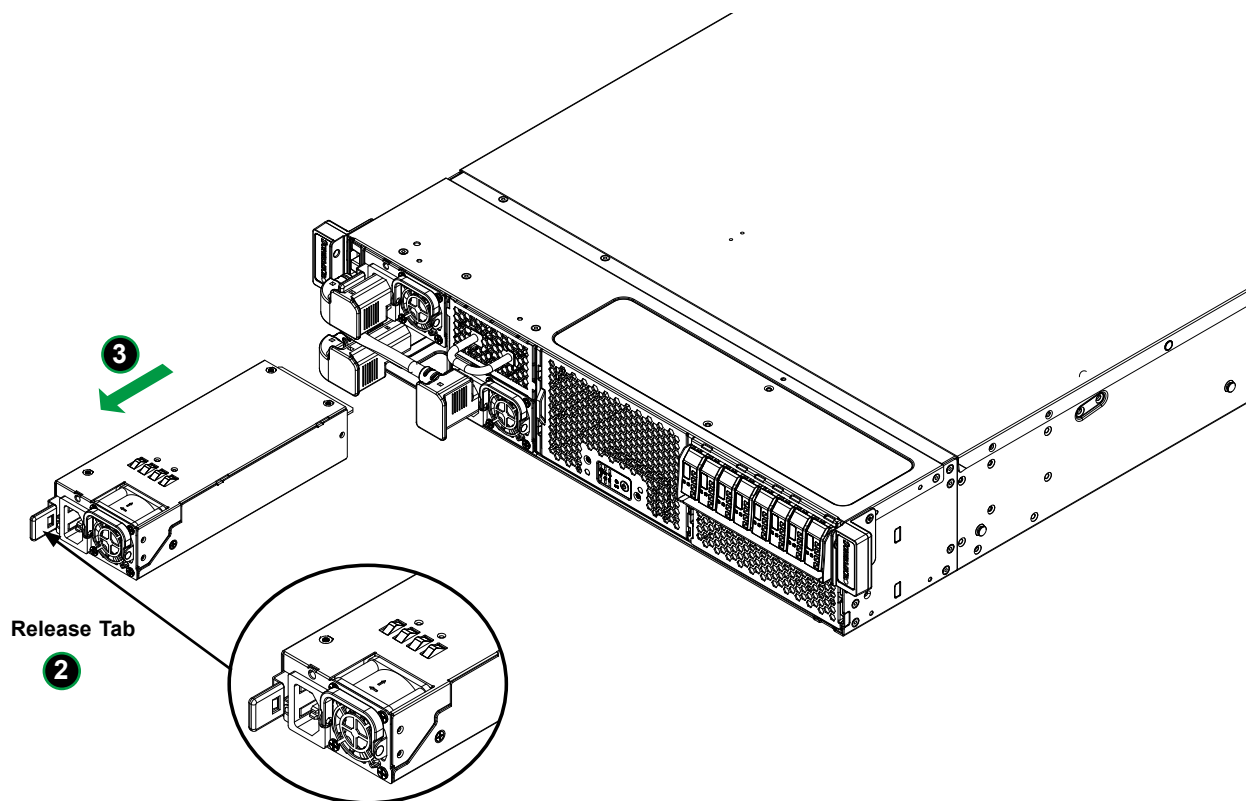

**Figure 3-8. Installing a Power Supply Module**

### 3.9 Installing PCIe Cards/GPU

The system provides seven PCIe expansion slots that each supports four double-width PCIe cards or GPUs and three single-width PCIe cards. PCIe cards and GPUs must be installed by the manufacturer.

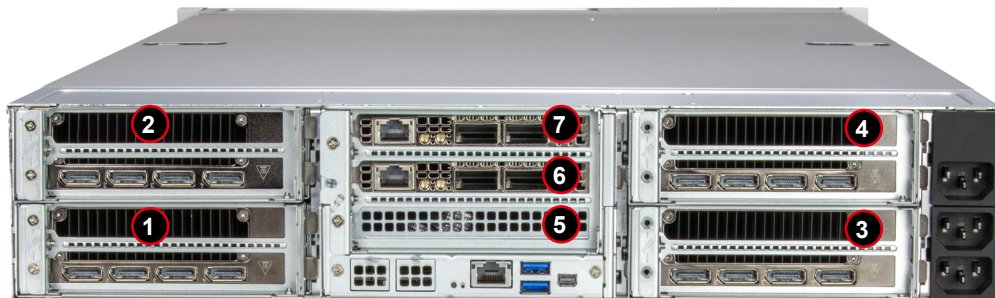

Figure 3-9. GPU or PCIe Bays

#### *Installing an Expansion Card*

1. Power down the system and remove both covers as described earlier in this section.
2. On the back of the chassis, pull the module towards the rear, there are no screws to remove.
3. Unscrew and remove the PCIe slot covers from the module.
4. Secure the PCIe card and bracket into the module's PCIe slot using the screw previously set aside.
5. Replace the PCIe assembly back into the chassis.
6. Replace the top covers and power up the system.

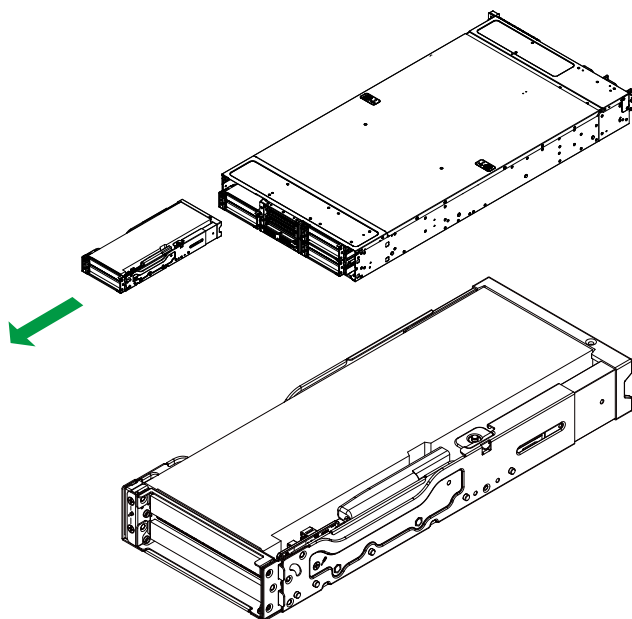

Figure 3-10. Removing the PCIe Slot Shield

# Chapter 4

## Motherboard Connections

This section describes the connections on the motherboard and provides pinout definitions. Note that depending on how the system is configured, not all connections are required. The LEDs on the motherboard are also described here. A motherboard layout indicating component locations may be found in [Chapter 1](#). More detail can be found in the [Motherboard Manual](#). Please review the Safety Precautions in [Appendix A](#) before installing or removing components.

### 4.1 Power Connections

#### 12 V 8-pin Main Power Supply Connector (JPWR1-JPWR4)

JPWR1-4 is an 8-pin ATX power input to provide primary power to the motherboard. Refer to the table below for pin definitions.

12 V 8-pin Power Connector Pin Definitions			
Pin#	Definition	Pin#	Definition
1	Ground	5	+12 V
2	Ground	6	+12 V
3	Ground	7	+12 V
4	Ground	8	+12 V

#### 12 V 2-pin Main Power Supply Connector (JPWR7)

JPWR7 is a 2-pin ATX power input to provide primary power to the motherboard. Refer to the table below for pin definitions.

12 V 2-pin Connector Pin Definitions			
Pin#	Definition	Pin#	Definition
1	Ground	2	+12 V

#### 12 V 8-pin Backplane Power Supply Connector (JPWR5)

JPWR5 is an 8-pin ATX power input to provide power to the backplane. Refer to the table below for pin definitions.

12 V 8-pin Power Connector Pin Definitions			
Pin#	Definition	Pin#	Definition
1	Ground	5	+12 V
2	Ground	6	+12 V
3	Ground	7	+12 V
4	Ground	8	+12 V

### 12 V 8-pin IO Board Power Supply Connector (JPWR6)

JPWR6 is an 8-pin ATX power input to provide power to the I/O board. Refer to the table below for pin definitions.

12 V 8-pin Power Connector Pin Definitions			
Pin#	Definition	Pin#	Definition
1	Ground	5	+12 V
2	Ground	6	+12 V
3	Ground	7	+12 V
4	Ground	8	+12 V

### 12 V 20-pin Main Power Supply Sideband Connector (JSB2)

JPWR8 is a 20-pin ATX power input to provide power to the backplane. Refer to the table below for pin definitions.

12 V 8-pin Power Connector Pin Definitions			
Pin#	Definition	Pin#	Definition
1	PSU1_PRSENT	11	N.A.
2	PSU2_PRSENT	12	SMB_DATA
3	PSU3_PRSENT	13	N.A.
4	PSU4_PRSENT	14	SMB_SCL
5	PSU1_PWROK	15	N.A.
6	PSU2_PWROK	16	Ground
7	PSU3_PWROK	17	N.A.
8	PSU4_PWROK	18	PSU_12V_SENSE
9	PSU_PWRON	19	N.A.
10	SMB_ALERT	20	PSU_12V_SENSE_RTN

### TPM/Port 80 Header

A Trusted Platform Module (TPM)/Port 80 header is located at JTPM1 to provide TPM support and Port 80 connection. Use this header to enhance system performance and data security. Refer to the table below for pin definitions. Please go to the following link for more information on the TPM: <http://www.supermicro.com/manuals/other/TPM.pdf>.

Trusted Platform Module Header Pin Definitions			
Pin#	Definition	Pin#	Definition
1	+3.3 V	6	GND
2	SPI_CS#	7	SPI_MOSI
3	RESET#	8	N.A.
4	SPI_MOSI	9	+3.3V_STBY
5	SPI_CLK	10	SPI_IRQ#

## Expansion Slots

The motherboard can support seven expansion slots via a PCIe Gen 5 riser card. The table below describes each slot's type and speed.

Expansion Slots	
Name	Description
LWIO	Left-hand riser card slot supports PCIe 5.0 x16
RWIO	Right-hand riser card slot supports PCIe 5.0 x16
AIOM1	AIOM (Advanced I/O Module) supports PCIe 5.0 x16 with NCSI
AIOM2	AIOM (Advanced I/O Module) supports PCIe 5.0 x16

## Onboard Battery (BT1)

The onboard back up battery is located at BT1. The onboard battery provides backup power to the on-chip CMOS, which stores the BIOS setup information. It also provides power to the Real Time Clock (RTC) to keep it running.

## Chassis Intrusion (JL1)

A Chassis Intrusion header is located at JL1 on the motherboard. Attach the appropriate cable from the chassis to the header to inform you when the chassis has been opened.

Chassis Intrusion Pin Definitions	
Pins	Definition
1	Intrusion Input
2	Ground

## 4.2 Headers and Connectors

### Power SMB Header (PWRI2C)

Power System Management Bus (I<sup>2</sup>C) header monitors power supply, fan and system temperatures. See the table below for pin definitions.

Power SMB Header Pin Definitions	
Pin#	Definition
1	Clock
2	Data
3	Alert
4	Ground
5	+3.3 V

## Front Control Panel

JFP1 contains header pins for various buttons and indicators that are normally located on a control panel at the front of the chassis. These connectors are designed specifically for use with Supermicro chassis. See the figure below for the location of JFP1.

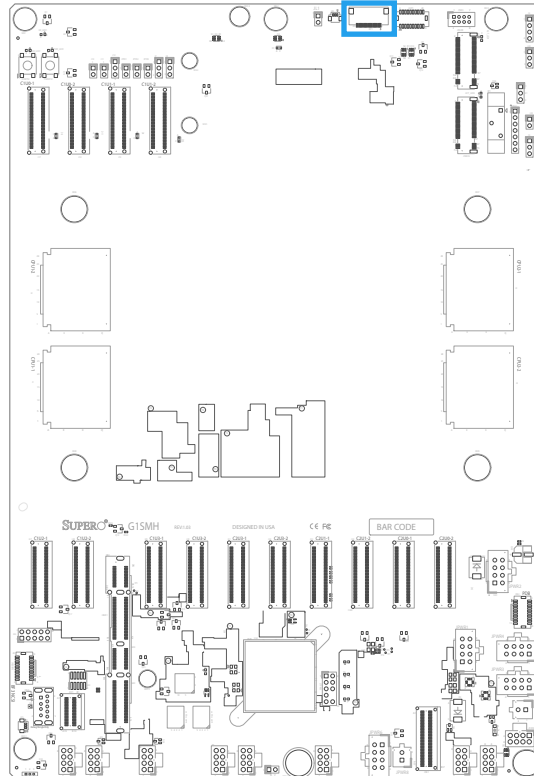

### JFP1

1	○	Power Button
2	○	UID Reset Switch
3	○	UID LED
4	○	Power Fail LED
5	○	N/A
6	○	N/A
7	○	Drive Activity LED
8	○	Standby Power LED
9	○	Normal Power LED
10	○	N/A
11	○	Ground
12	○	N/A
13	○	N/A
14	○	N/A
15	○	N/A
16	○	N/A
17	○	N/A
18	○	N/A
19	○	N/A
20	○	N/A

Figure 4-1. JFP1 Pin Definitions

## Front Control Panel Pin Definitions

### Power LED

The Power LED connection is located on pins 8 and 9 of JFP1. Refer to the table below for pin definitions.

Power LED Pin Definitions (JF1)	
Pin#	Definition
8	Standby Power LED-
9	Normal Power LED-

### Drive Activity LED

The Drive Activity LED connection is located on pin 7 of JFP1. Attach a drive LED cable here to display disk activity detected on the motherboard's built-in disk controllers. See the table below for pin definitions.

Drive Activity LED Pin Definitions (JF1)	
Pin#	Definition
7	Drive Activity LED

### Power Fail LED

The Power Fail LED connection is located on pin 4 of JFP1. Refer to the table below for pin definitions.

Power Fail LED Pin Definitions (JFP1)	
Pin#	Definition
4	Power Fail LED-

## UID LED

The UID LED is on pin 3 of JFP1. Connect the front panel UID LED to this header to indicate when the rear UID switch is turned on. Refer to the table below for pin definitions.

UID LED Pin Definitions (JFP1)	
Pin#	Definition
3	UID LED-

## UID Reset Button

The UID Reset Button connection is located on pins 2 and 11 of JFP1. Attach the hardware UID reset switch from the computer case to this header to reset the system. Refer to the table below for pin definitions.

UID Reset Button Pin Definitions (JFP1)	
Pin#	Definition
2	UID Reset Switch
11	Ground

## Power Button

The Power Button connection is located on pins 1 and 11 of JFP1. Momentarily contacting both pins will power on/off the system. This button can also be configured to function as a suspend button. To turn off the power in the suspend mode, press the button for at least 4 seconds. Refer to the table below for pin definitions.

Power Button Pin Definitions (JFP1)	
Pin#	Definition
1	Power Button
11	Ground

## 4.3 LED Indicators

### UID LED (UID\_LED1)

The UID LED is located next to two buttons at one of the corners of the motherboard. One of the buttons is the UIDBTN1 button. Press this button and the LED will blink blue to show that the UID is active. Press the UIDBTN1 button for one second and the LED will turn solid blue. Use this UID LED to 'mark' the system, so the motherboard can be easily identified. See the table below for more information.

UID LED States		
Color	State	Definition
None	Off	UID Off
Blue	Solid On	Unit Identified by Local Site
Blue	Slow Blinking	Unit Identified by Remote Site
Blue	Slow Blinking	System Recovery

### CPLD Initialization LED (HB\_LED1)

The CPLD Initialization LED is located next to two buttons at one of the corners of the motherboard. When the the LED is blinking green it indicates that the CPLD has been initialized. See the table below for more information.

CPLD Initialization LED States		
Color	State	Definition
None	Off	CPLD Uninitialized
Green	Blinking	CPLD Initialization OK

### Motherboard Power LED (PWR\_LED1)

A motherboard power LED is located next to two buttons at one of the corners of the motherboard. Press the PWRBTN1 and the LED will be solid green. See the table below for more information.

Motherboard Power LED State		
Color	State	Definition
Green	Solid On	BMC is not ready
Green	Blinking	BMC Normal
Green	Fast Blinking	BMC: Initializing

### M.2 Activity LEDs

ACT\_LED1 and ACT\_LED2 are onboard M.2 LEDs. When these LEDs are blinking green, the M.2 SSD is active.

M.2 Activity LEDs		
LED Color	State	Definition
None	Off	M.2 Inactive
Green	Blinking	M.2 Active

### EROT Detected LEDs (LED1 and LED2)

The EROT Detected OK LED (LED1) and the EROT Detected Fail LED (LED2) shows the status of the Root-of-Trust (RoT). LED1 is solid yellow if the RoT is in a good state. LED2 is solid red if there is an error. See the tables below for more information.

Root-of-Trust LED1 State		
Color	State	Definition
Yellow	Solid On	Root-of-Trust is OK

Root-of-Trust LED2 State		
Color	State	Definition
Red	Solid On	Error detected

### Normal Power Detected LED (LED3)

The Normal Power Detected LED indicates the motherboard is on normal power. Before pressing PWRBTN1, the LED blinks green. After pressing PWRBTN1, the LED is solid green.

Normal Power Detected LED State		
Color	State	Definition
Green	Blinking	Normal Power not detected
Green	Solid	Normal Power detected

### Standby Power Detected LED (LED4)

The Standby Power Detected LED indicates the motherboard is on standby power. Before pressing PWRBTN1, the LED is solid orange. After pressing PWRBTN1, the LED is off.

BMC Heartbeat LED State		
Color	State	Definition
Orange	Solid	Standby Power detected
Orange	Off	Stanby Power not detected

## 4.4 M.2 Solid State Drive Installation

### Installing Dual M.2 SSDs

1. Disconnect power from the motherboard or system.
2. Refer to the [motherboard layout](#) and locate the M.2 dual slot (JM2A and JM2B).
3. Insert the lower M.2 sideways into the connector so that it lays flat, then follow the instructions below from ① to ③.
4. Insert the upper M.2 sideways into the connector so that it lays flat, then follow the instructions below from ④ to ⑥.

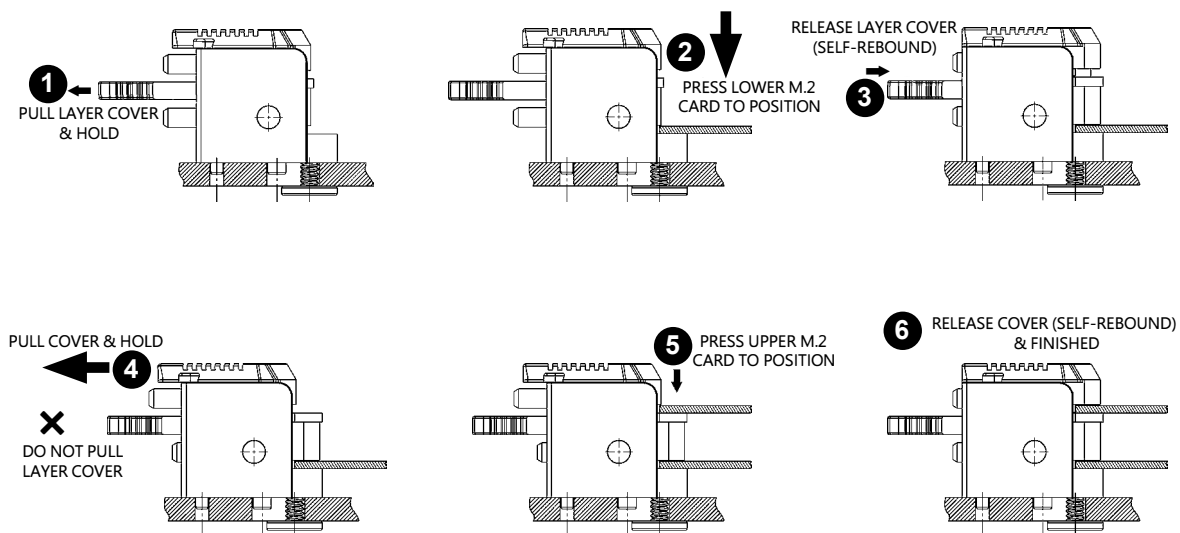

Figure 4-2. Installing Dual M.2 SSDs

### Releasing Dual M.2 SSDs

1. Follow the instructions below from ① to ⑤ to remove M.2 SSDs.

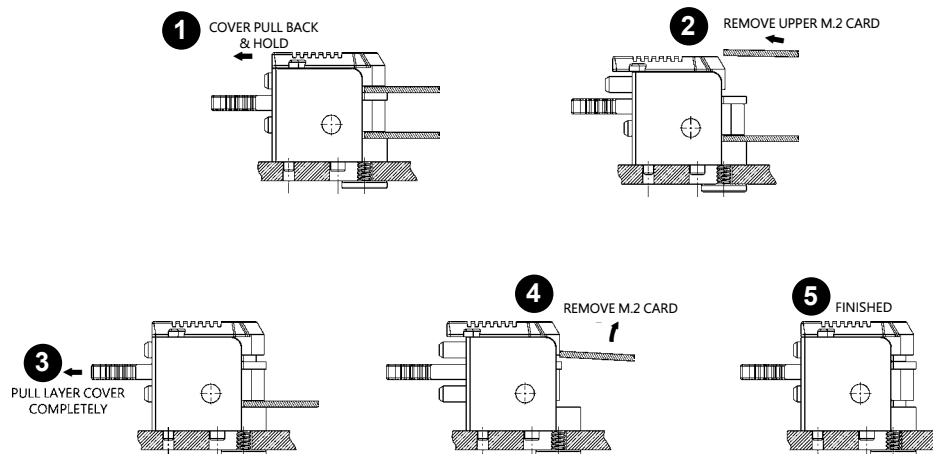

Figure 4-3. Releasing Dual M.2 SSDs

## Chapter 5

# Software

After the hardware has been installed, you can boot the Operating System (OS).

### 5.1 Ubuntu® Server 22.04 ISO Installation

**Prerequisites:** The repositories can be accessed from the internet. If you are using a proxy server, follow the instructions in the [Ubuntu Server Installation Guide](#) to ensure that the system can access the necessary URIs. Obtain the Ubuntu Server ISO for Arm® image (aarch64) and store it on your local disk. Refer to [Downloading Ubuntu Server](#) for the instructions.

#### **Booting Ubuntu Server 22.04 ISO Remotely**

1. Connect to the BMC. Open a browser in your LAN, navigate to <https://<BMC-IP-address>/>, and log in.
2. Download the ISO image to a location that can be accessed by the browser.

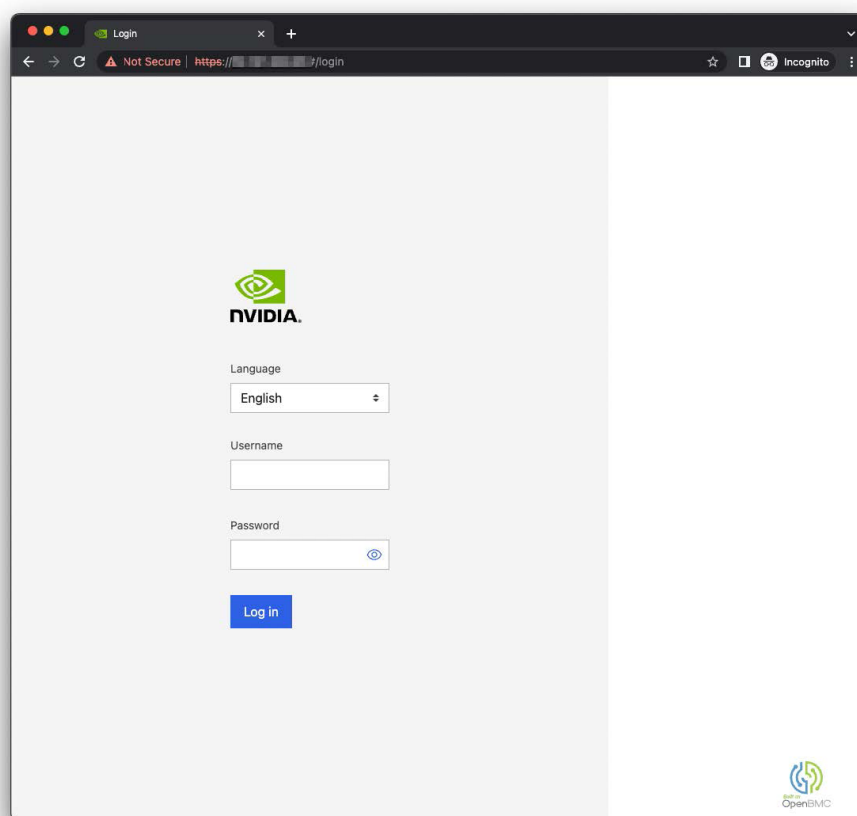

3. Set up the ISO image as virtual media.
  - a. From the left hand menu, expand **Operations**.
  - b. Select **Virtual media**.
  - c. Click **Add file**, navigate to the downloaded ISO image, and select it.
  - d. To begin serving the ISO image to the target server, click **Start**.
4. Boot from the virtual media. Typically, the default boot order does not boot the CD-ROM image. You can change this in the BIOS or as a one-time option in the boot menu.

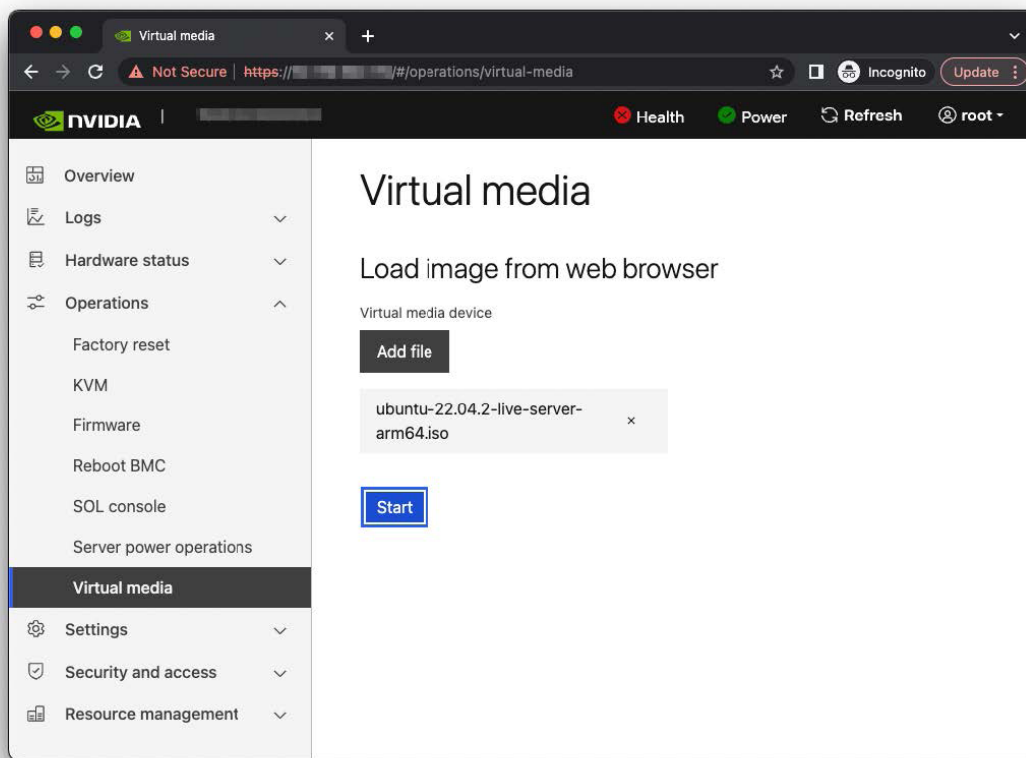

- a. Connect to the console.
  - i. From the left hand menu, expand **Operations**, and select the **SOL console**.
  - ii. Alternatively, SSH to the BMC from a terminal emulator, log in, and at the prompt, run the `obmc-console-client` command.
- b. To bring up the boot menu, press **Escape** or **F11** at the beginning of the boot process.
- c. In the boot menu, select **UEFI OpenBMC Virtual Media Device** as the boot device and press **Enter**.
- d. Follow the instructions in Installing Ubuntu Server.

```
Terminal
PROGRESS CODE: V02010004 I0
PROGRESS CODE: V02010004 I0
PROGRESS CODE: V02010004 I0
PROGRESS CODE: V02010004 I0
PROGRESS CODE: V02010004 I0
PROGRESS CODE: V02010004 I0
PROGRESS CODE: V02020000 I0
PROGRESS CODE: V02020000 I0
PROGRESS CODE: V02020000 I0
PROGRESS CODE: V02020000 I0
PROGRESS CODE: V03040002 I0
PROGRESS CODE: V03040003 I0
PROGRESS CODE: V03040002 I0
PROGRESS CODE: V03040003 I0
PROGRESS CODE: V03040002 I0
PROGRESS CODE: V03040003 I0
PROGRESS CODE: V03040002 I0
PROGRESS CODE: V03040003 I0
PROGRESS CODE: V03040002 I0
PROGRESS CODE: V03040003 I0
PROGRESS CODE: V03040002 I0
PROGRESS CODE: V03040003 I0
PROGRESS CODE: V02020000 I0
PROGRESS CODE: V02020000 I0
Server System firmware version          date _____
ESC   to enter Setup.
F11   to enter Boot Manager Menu.
Enter to continue boot.
BMC IPv4 Address: _____
** WARNING: Test Key is used. **
```

```
Terminal
Grace Hopper x4 P4496
TH500                                3.39 GHz
                                        491520 MB RAM

WARNING: Test key detected.

  Select Language          <English>          This selection will
                                        take you to the Boot
                                        Manager

> Device Manager
> Boot Manager
> Boot Maintenance Manager

Continue
Reset

^v=Move Highlight      <Enter>=Select Entry
```

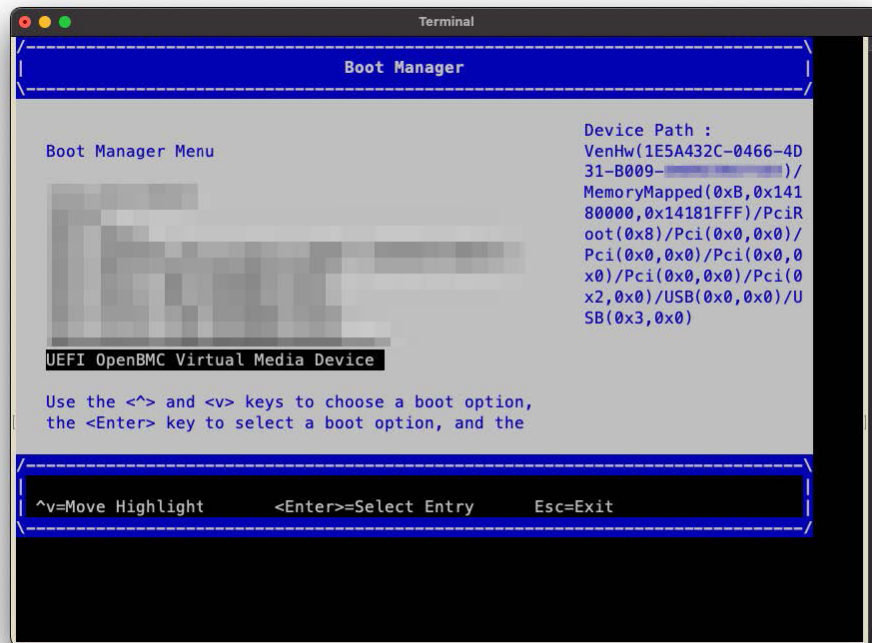

## Installing Ubuntu Server

**Prerequisites:** This section assumes you have already booted the Ubuntu ISO image.

1. After booting the ISO image, the GRUB boot menu will appear. The menu will time out after 60 seconds. If no action is taken, it will proceed with booting the default selection (**Try or Install Ubuntu Server**).

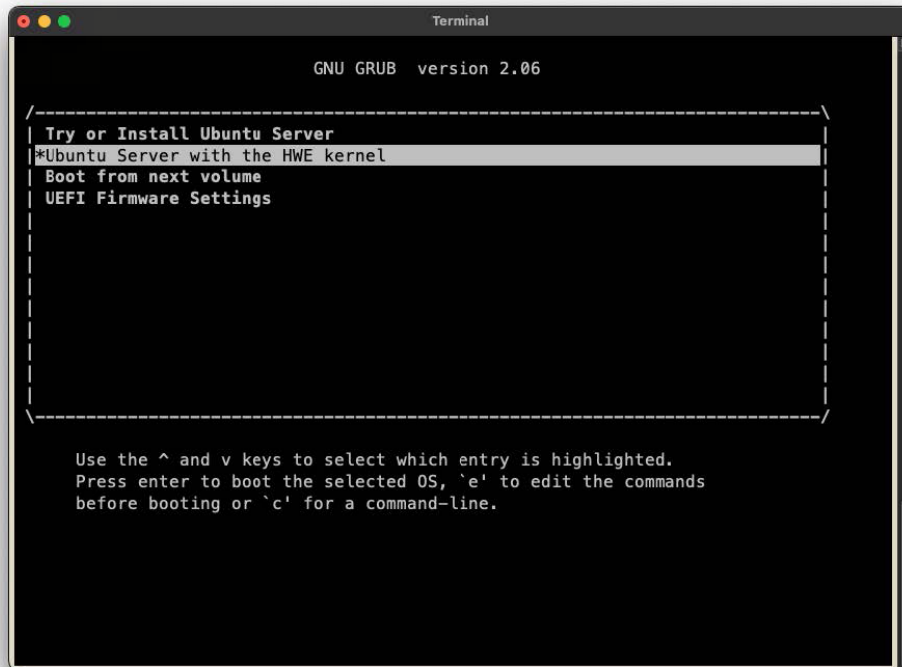

2. To automate the installation with an autoinstall configuration file, refer to Installing with Autoinstall.
3. Select **Ubuntu Server with the HWE kernel**. Refer to the Ubuntu Server Installer Operations for guidance on using the installer. The performance of the Virtual Media device on Grace systems has been known to interfere with the Ubuntu installer, and this issue can cause services and cloud-init to time out. When this is experienced, a hybrid approach to load the kernel and initial ramdisk and use the network to load the rest of the ISO is required:
  - a. Host the Ubuntu Server ISO from a web server. This can be an existing web server or a spontaneous web server.
  - b. Ensure that **Ubuntu Server with the HWE kernel** selected and press **e** from the GRUB boot menu.
  - c. Append `ip=dhcp` and `url=http://webserver:port/path/to/UbuntuServer.iso` to the list of kernel boot parameters. When the system has multiple network interfaces, you might be required to configure an interface with DHCP. This can be accomplished by specifying `ip=:::interface_name:::dhcp:::` instead of `ip=dhcp`, and this format can also be used to configure the interface with a static IP address configuration. Refer to the `nfsroot` documentation for more information about how to use this kernel boot parameter.

- d. To boot, click **Ctrl+X** or press **F10**. The kernel will display output messages to the console after it begins to boot.
  - e. Stop the Virtual Media device from the BMC web browser console. The kernel will load the Ubuntu Server ISO from the network and start the installer.
4. Follow the installer prompts to configure the manual installation.
  5. Select the text-based installer mode and update the installer if necessary.

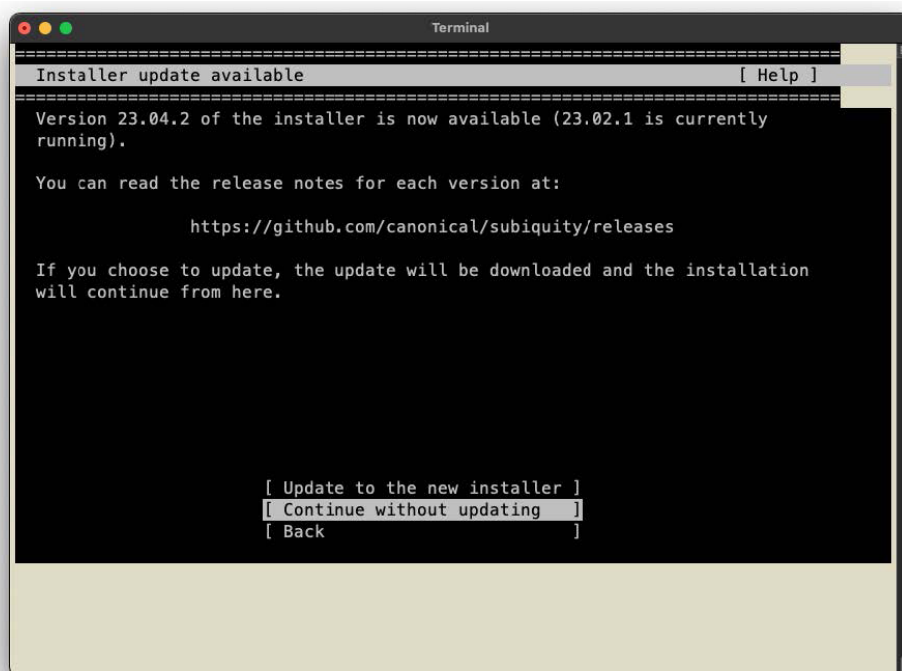

6. Select the **Keyboard** configuration.

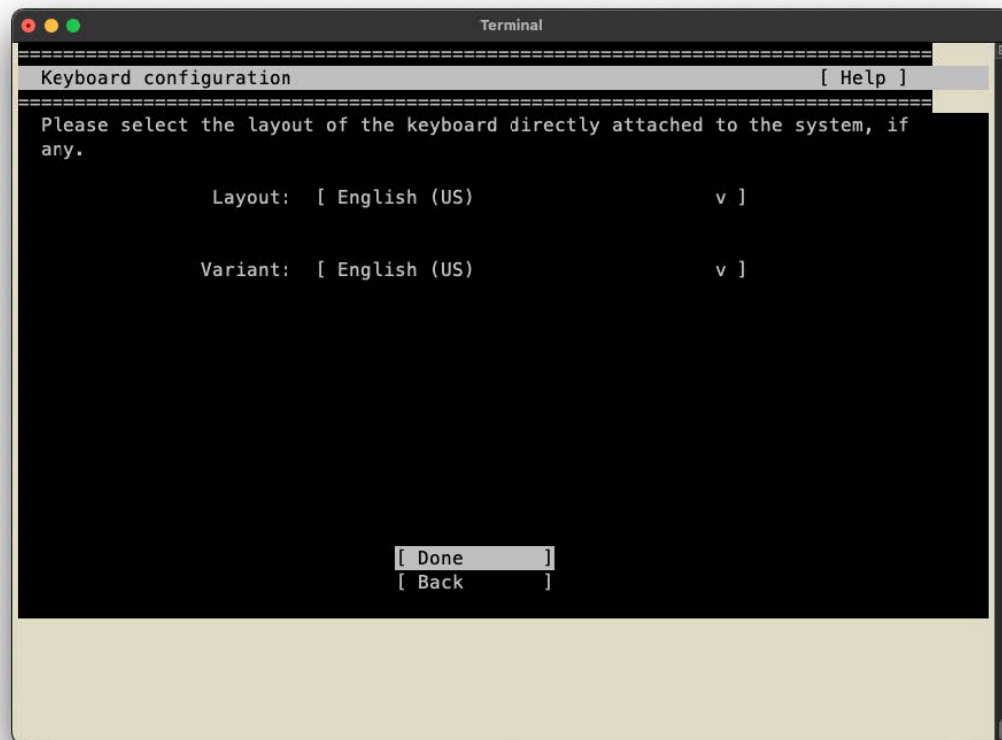

7. Select the base for the installation.

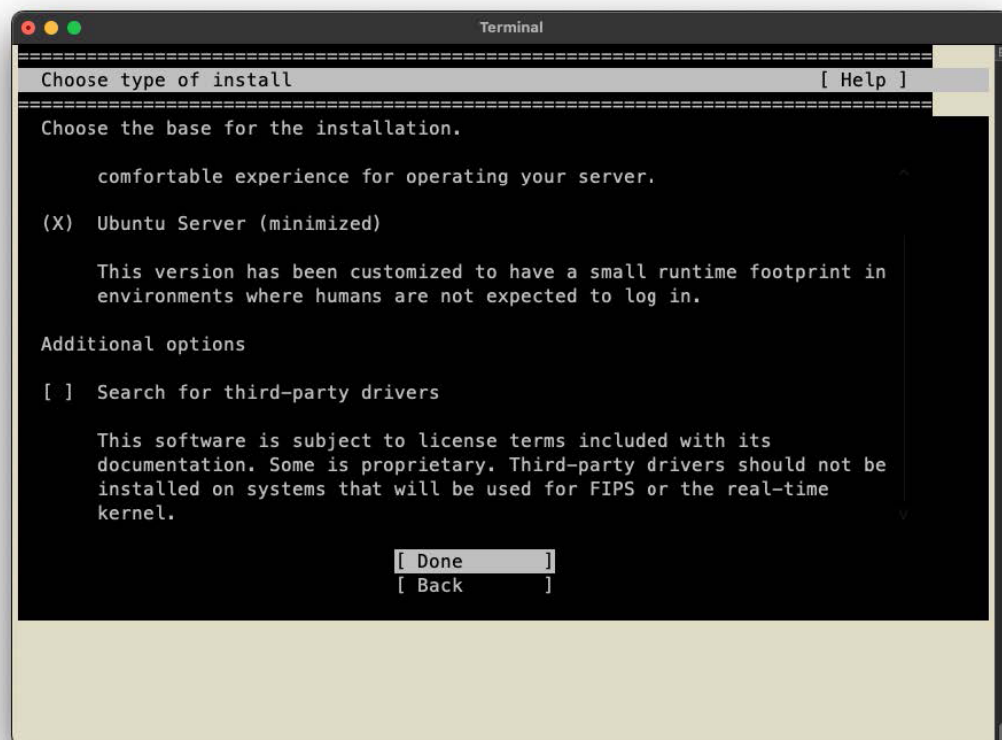

8. Configure the network connections, proxy settings, and Ubuntu archive mirror.

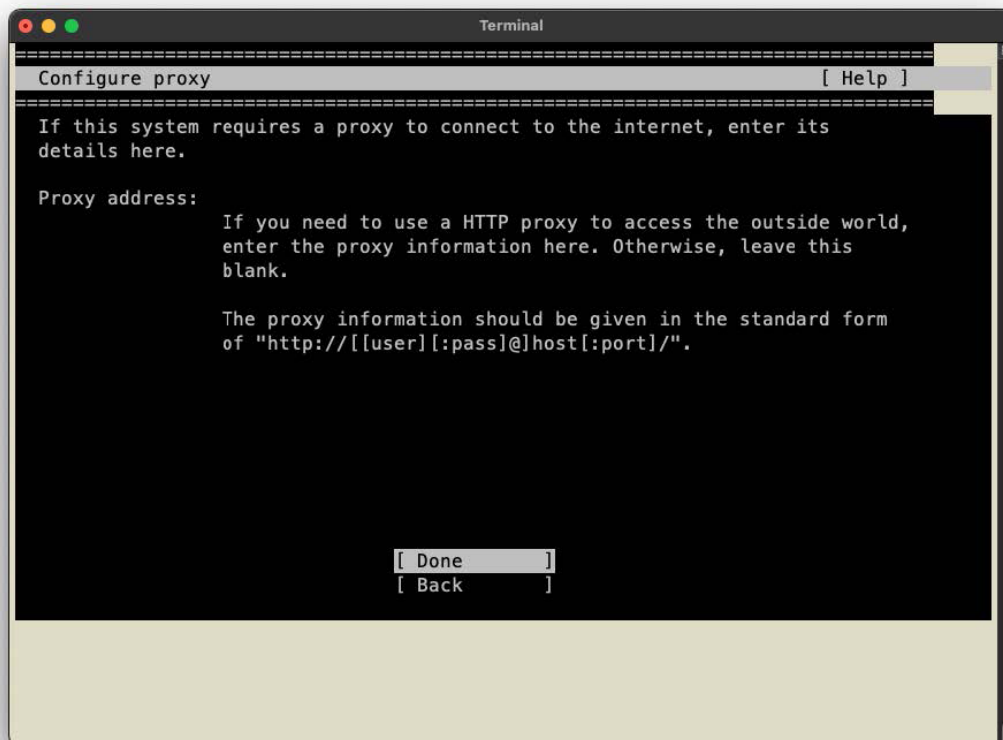
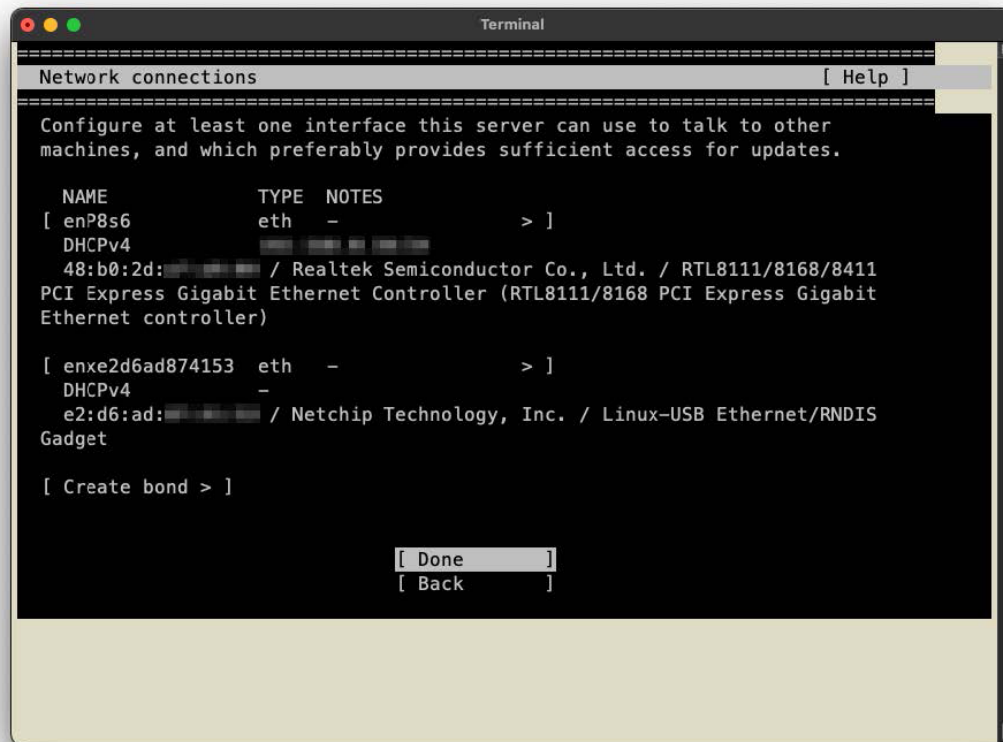

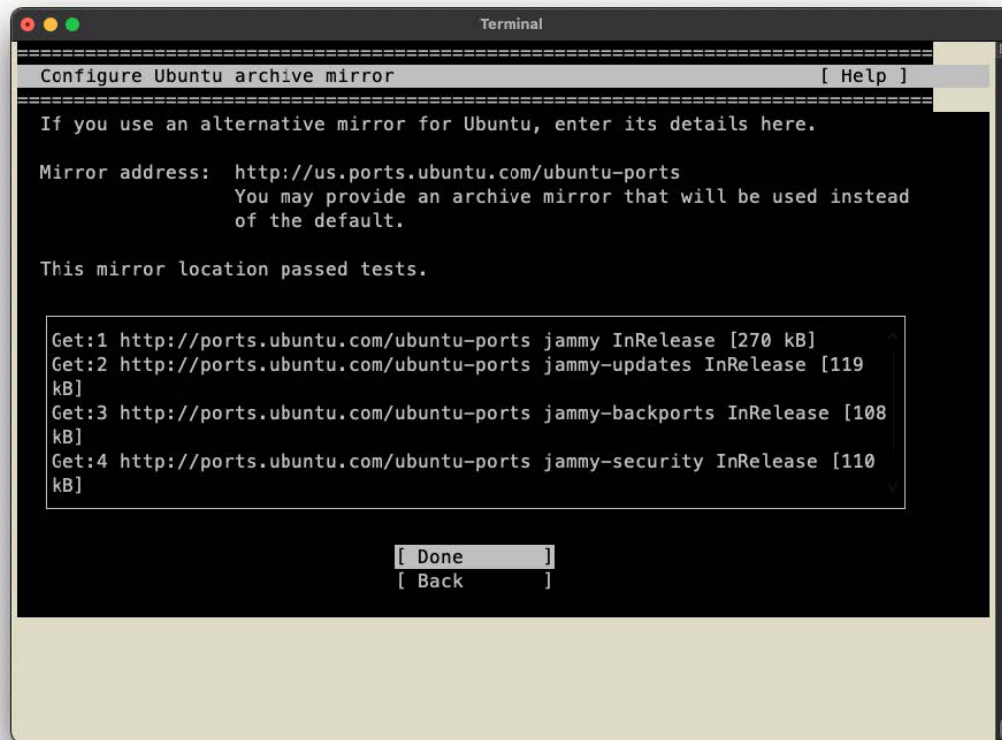

9. Select a storage configuration and confirm the destructive action.

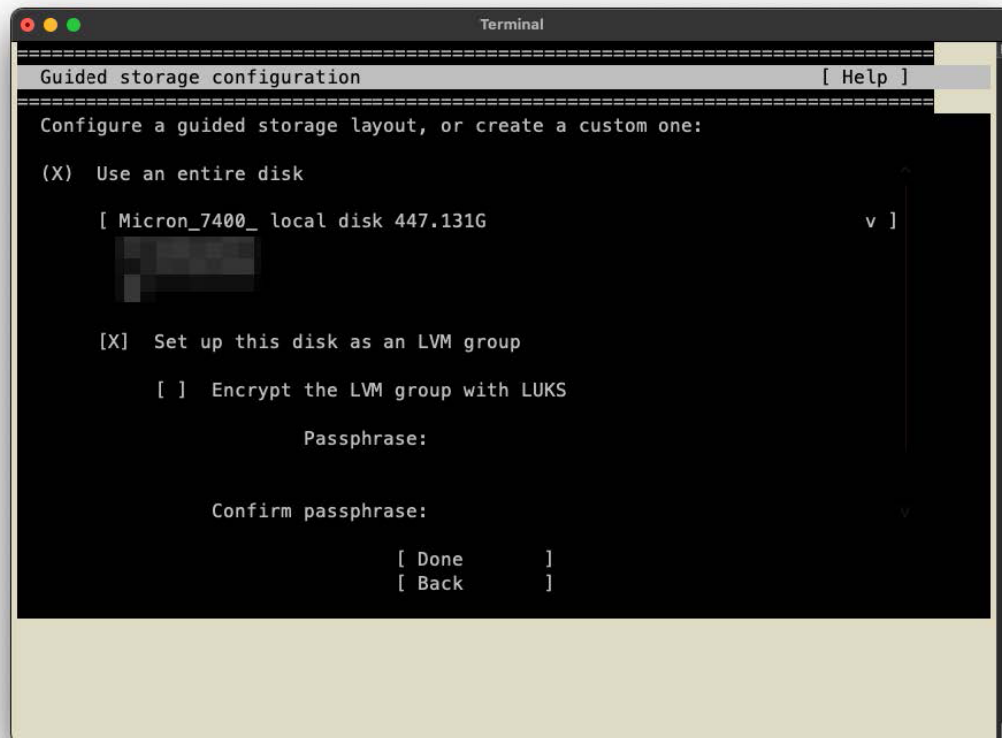



```
Terminal
=====
Storage configuration [ Help ]
=====
FILE SYSTEM SUMMARY

MOUNT POINT  SIZE  TYPE  DEVICE TYPE
[ /          100.000G  new ext4  new LVM logical volume  > ]
[ /boot     2.000G  new ext4  new partition of local disk > ]
[ /boot/efi 1.049G  new fat32  new partition of local disk > ]

AVAILABLE DEVICES

DEVICE                                TYPE                SIZE
[ ubuntu-vg (new)                    LVM volume group   444.078G > ]
  free space                          344.078G > ]

[ Create software RAID (md) > ]
[ Create volume group (LVM) > ]

[ Done ]
[ Reset ]
[ Back ]
```

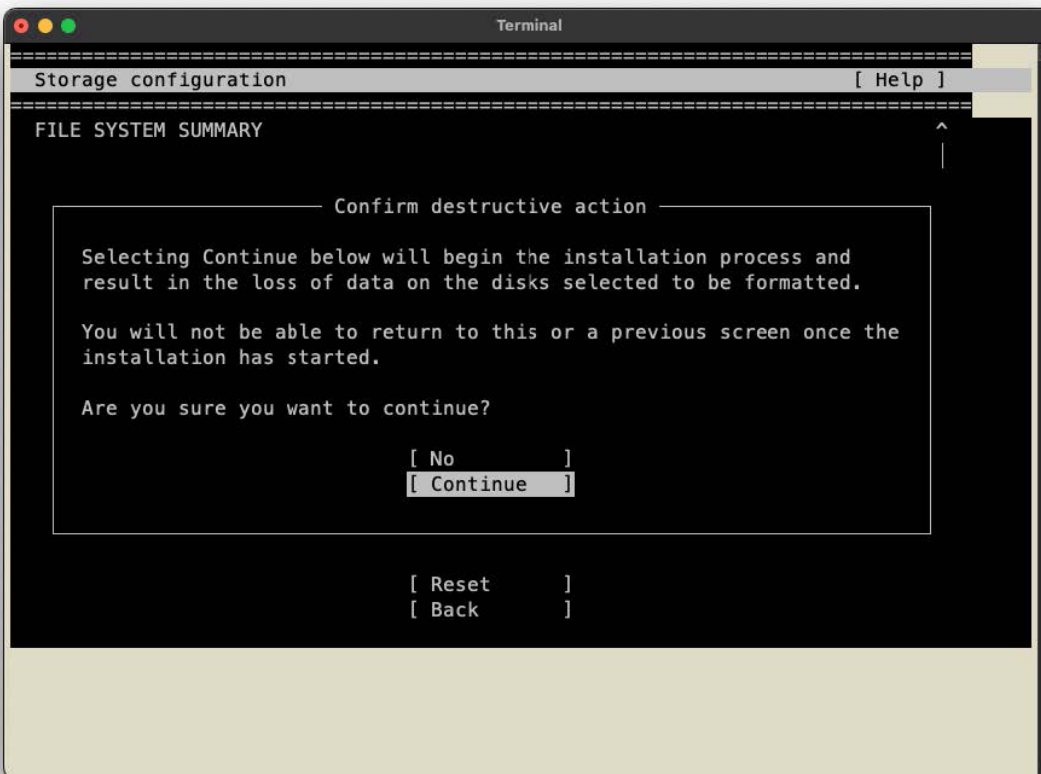

```
Terminal
=====
Storage configuration [ Help ]
=====
FILE SYSTEM SUMMARY

Confirm destructive action

Selecting Continue below will begin the installation process and
result in the loss of data on the disks selected to be formatted.

You will not be able to return to this or a previous screen once the
installation has started.

Are you sure you want to continue?

[ No ]
[ Continue ]

[ Reset ]
[ Back ]
```

10. Select the system hostname and create a username and password.

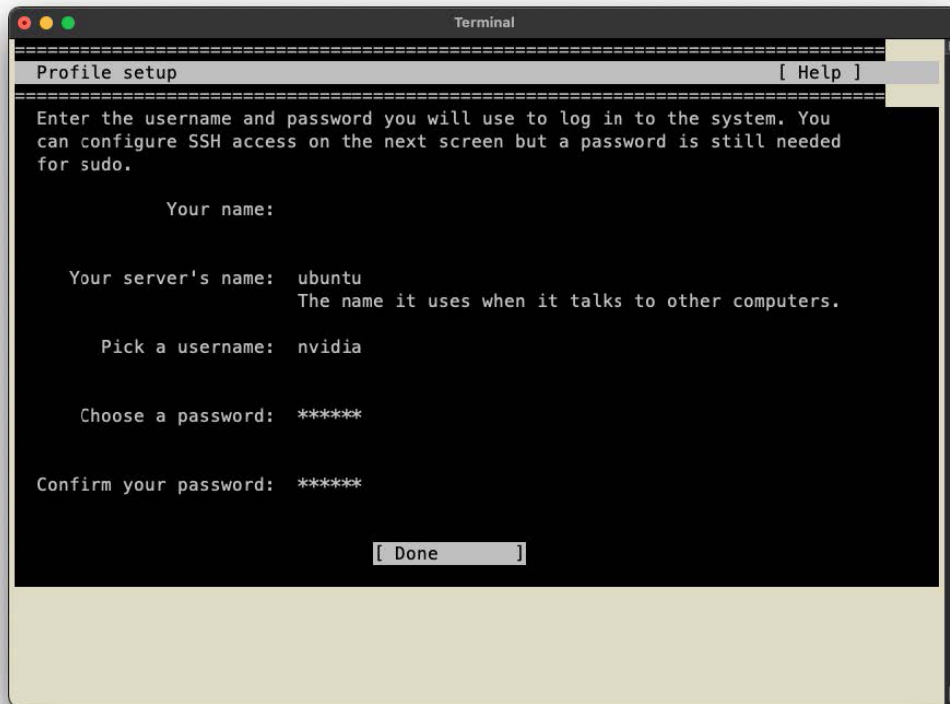

11. Select or decline Ubuntu Pro option for extended support from Canonical.

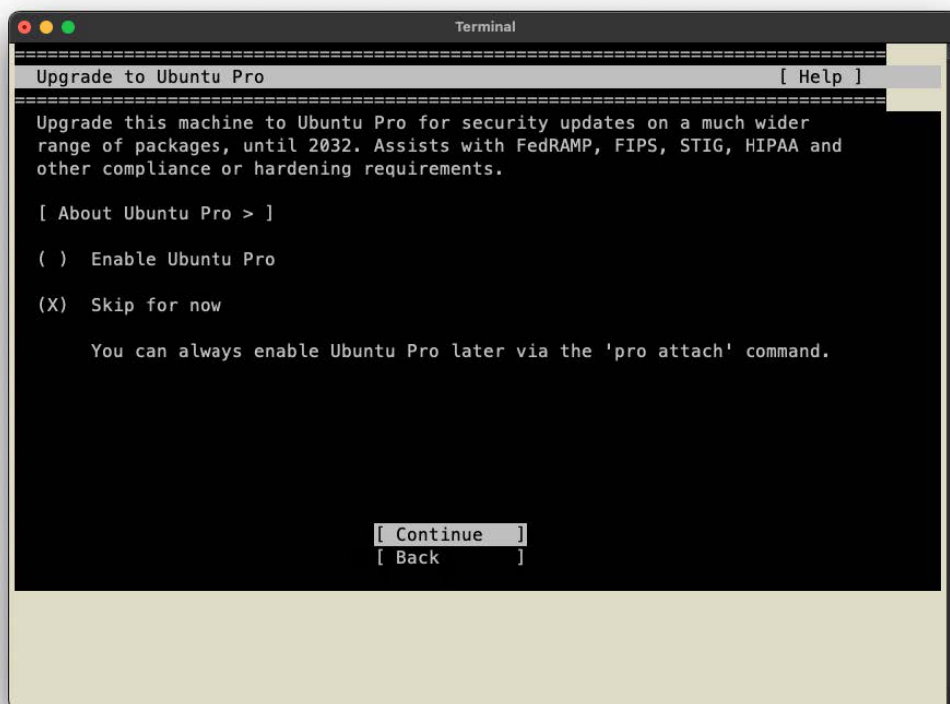

12. Select the system SSH server and settings.

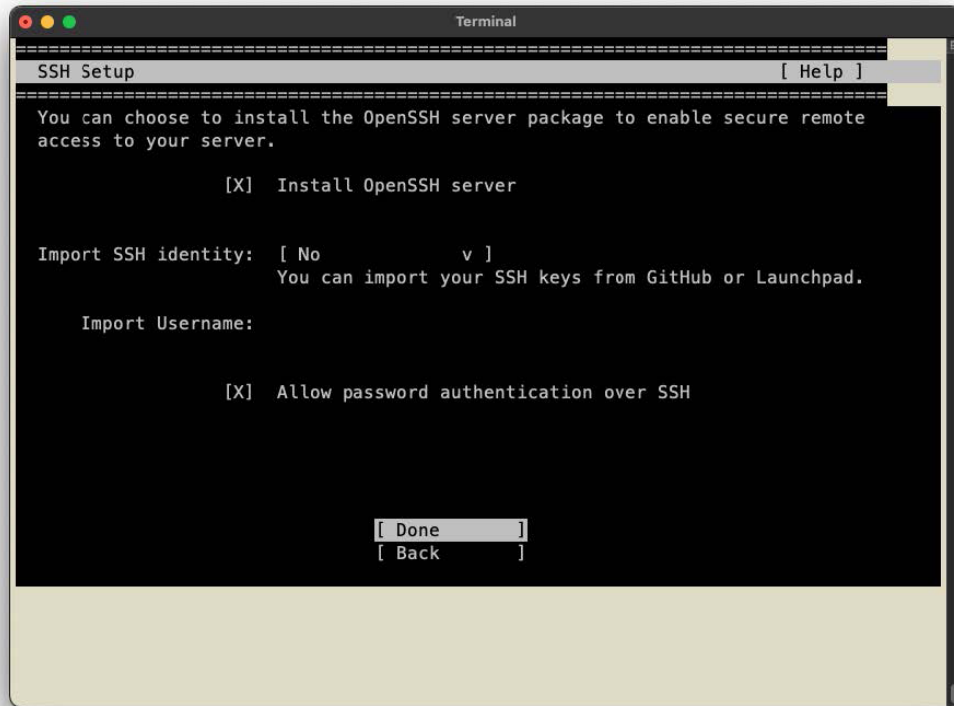

13. Select the featured Ubuntu server snaps.



- System installation begins, wait for the **Install Complete** banner and the **Reboot Now** option before proceeding to the next step.

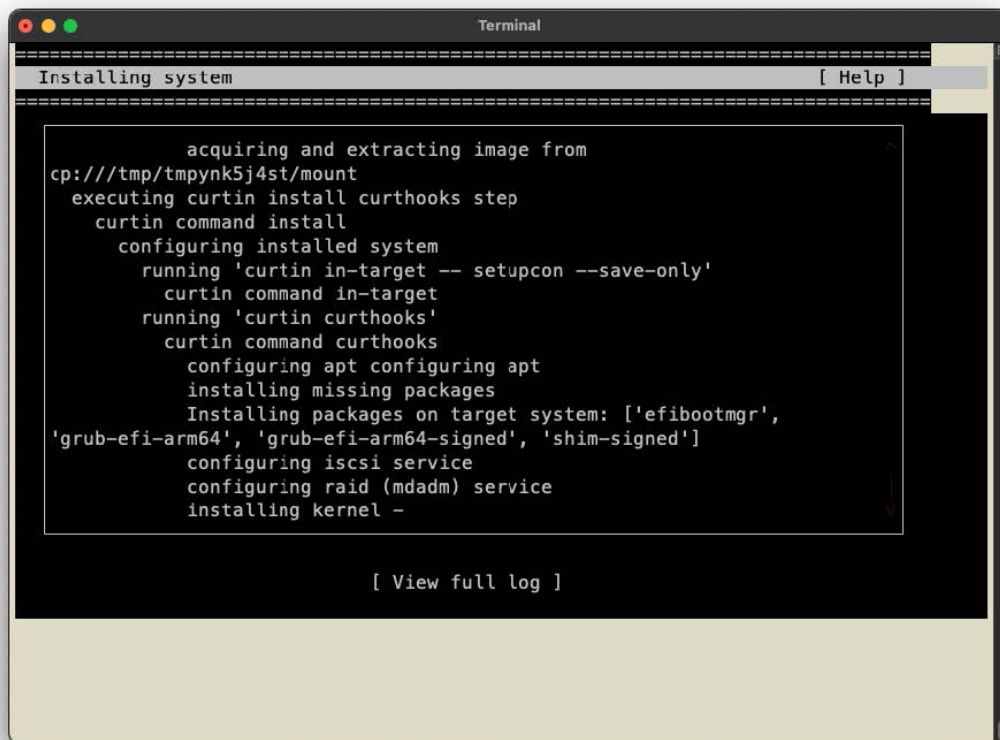

The terminal window displays the progress of system installation. The title bar reads "Installing system" and the top right corner has a "[ Help ]" button. The main content area shows a list of tasks being performed, including acquiring and extracting an image, executing curtin commands, configuring the installed system, running setupcon, installing missing packages, and configuring services like apt, iSCSI, RAID, and the kernel. A "[ View full log ]" link is visible at the bottom of the main content area.

```
acquiring and extracting image from
cp:///tmp/tmpynk5j4st/mount
executing curtin install curthooks step
curtin command install
configuring installed system
  running 'curtin in-target -- setupcon --save-only'
  curtin command in-target
  running 'curtin curthooks'
  curtin command curthooks
  configuring apt
  configuring apt
  installing missing packages
  Installing packages on target system: ['efibootmgr',
'grub-efi-arm64', 'grub-efi-arm64-signed', 'shim-signed']
  configuring iSCSI service
  configuring RAID (mdadm) service
  installing kernel -
```

[ View full log ]

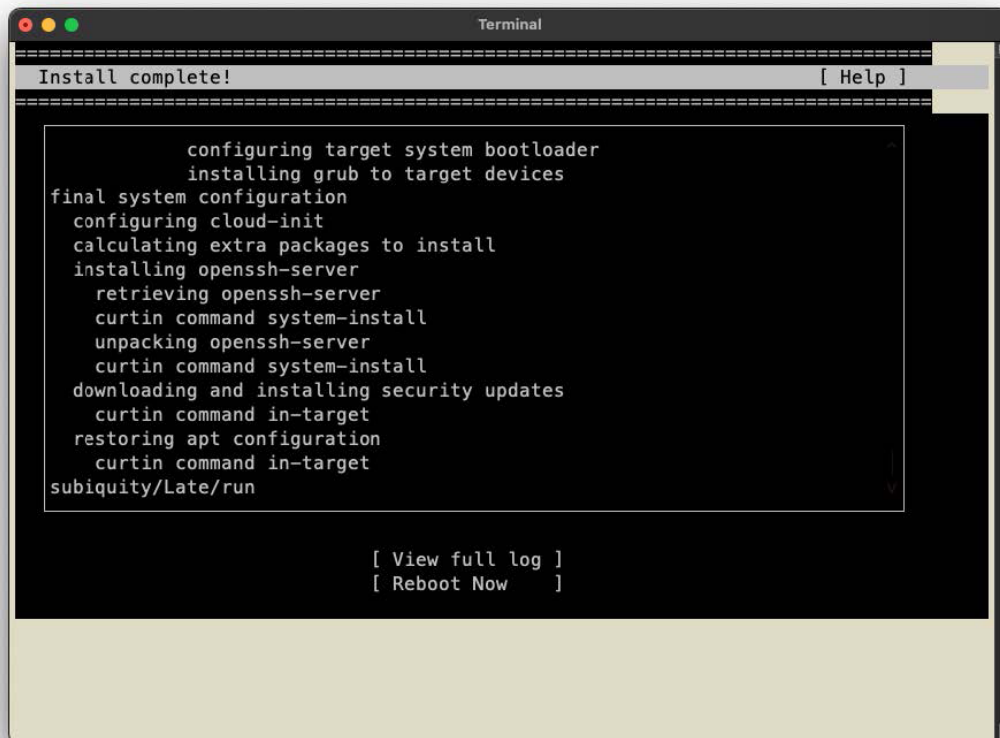

The terminal window displays the final steps of system installation. The title bar reads "Install complete!" and the top right corner has a "[ Help ]" button. The main content area shows tasks such as configuring the target system bootloader, installing GRUB, final system configuration, configuring cloud-init, calculating extra packages, installing openssh-server, downloading and installing security updates, restoring apt configuration, and running subiquity/Late/run. At the bottom of the main content area, there are two links: "[ View full log ]" and "[ Reboot Now ]".

```
configuring target system bootloader
installing grub to target devices
final system configuration
configuring cloud-init
calculating extra packages to install
installing openssh-server
  retrieving openssh-server
  curtin command system-install
  unpacking openssh-server
  curtin command system-install
downloading and installing security updates
  curtin command in-target
restoring apt configuration
  curtin command in-target
subiquity/Late/run
```

[ View full log ]  
[ Reboot Now ]

15. Once the installation has completed, **do not reboot**.
16. Use the **tab** key to navigate to the **Help** menu and press **Enter** to display the menu. From the menu, select **Enter shell**.

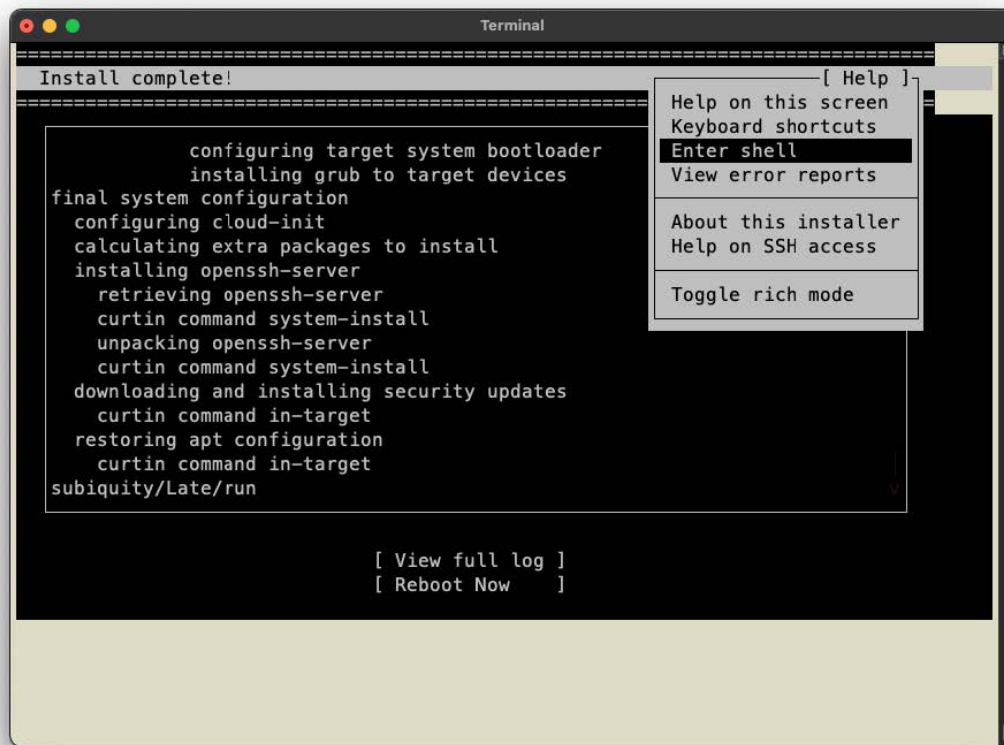

17. From the shell, to display the grub menu during boot, create

`/target/etc/default/grub.d/menu.cfg` with the following content:

```
GRUB_TIMEOUT_STYLE=menu
```

```
GRUB_TIMEOUT=5
```

```
GRUB_TERMINAL="console serial"
```

```
GRUB_CMDLINE_LINUX_DEFAULT=""
```

```
GRUB_SERIAL_COMMAND="$GRUB_SERIAL_COMMAND serial --unit=0
--speed=115200 --word==8
```

```
--parity=no --stop=1"
```

**Note:** Platform-dependent workarounds in the form of kernel boot parameters can be specified with `GRUB_CMDLINE_LINUX_DEFAULT` in this file.

18. From the shell, to update grub and install the NVIDIA optimized Ubuntu kernel variant, run the following commands:

```
mount --bind /dev /target/dev
cp /etc/resolv.conf /target/run/systemd/resolve/stub-resolv.conf
chroot /target
mount -t proc none /proc
mount -t sysfs none /sys
mount -t devpts none /dev/pts
apt update
apt install linux-nvidia-64k-hwe-22.04 -y
update-grub
exit
```

**Note:** When linux-nvidia-64k-hwe-22.04 is not available, install linux-nvidia-64k-6.2 instead.

19. Press **exit** to return from the shell to the installer.
20. From the installer, press the **tab** key to navigate to **Reboot Now**.
21. Press **Enter** to reboot the system.
22. The system will reboot.

The installation on Grace is now complete.

## 5.2 IPMI

The G1SMH supports the Intelligent Platform Management Interface (IPMI). IPMI is used to provide remote access, monitoring and management. There are several BIOS settings that are related to IPMI.

Supermicro ships standard products with a unique password for the BMC ADMIN user. This password can be found on a label on the motherboard.

For general documentation and information on IPMI, please visit our website at:

<http://www.supermicro.com/products/nfo/IPMI.cfm>.

## 5.3 BMC

For security, each system is assigned a unique default BMC password for the ADMIN user. This can be found on a sticker on the chassis and a sticker on the motherboard. The sticker also displays the BMC MAC address.



**Figure 5-3. BMC Password Label**

See Chapter 1 for the [locations](#) of the labels.

## Chapter 6

# Optional Components

This chapter describes optional system components and installation procedures.

### 6.1 Power Supply Modules

The default configuration includes three power supply modules. One more can be added

### 6.2 TPM Security Module

SPI capable TPM 2.0 with Infineon 9672 controller, horizontal form factor.

The JTPM1 header is used to connect a Trusted Platform Module (TPM). A TPM is a security device that supports encryption and authentication in storage drives. It enables the motherboard to deny access if the TPM associated with the storage drive is not installed in the system.

Details and installation procedures are at:

<http://www.supermicro.com/manuals/other/TPM.pdf>.

- AOM-TPM-9672V-O

# Chapter 7

## Troubleshooting and Support

### 7.1 Information Resources

#### Website

A great deal of information is available on the Supermicro [website](#).

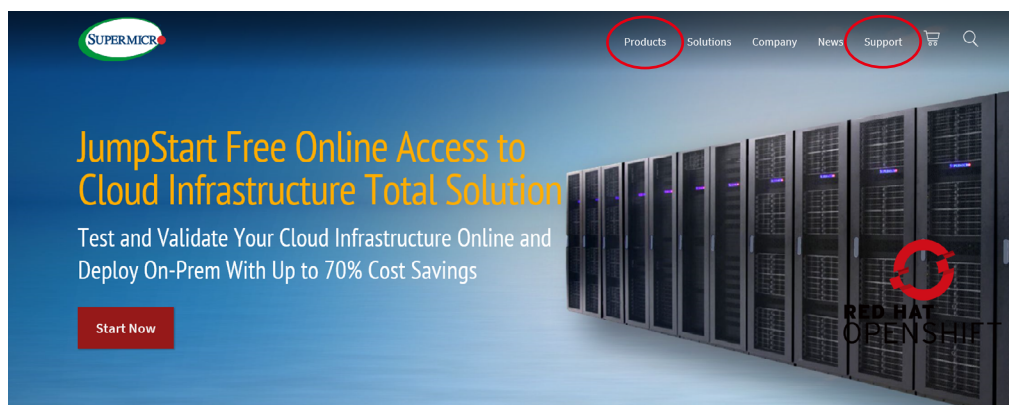

**Figure 7-1. Supermicro Website**

- Specifications for servers and other hardware are available by clicking **Products** option.
- The **Support** option offers downloads (manuals, BIOS/BMC, drivers, etc.), FAQs, RMA, warranty, and other service extensions.

#### ***Direct Links for the ARS-221GL-SR System***

[ARS-221GL-SR specifications page](#)

[G1SMH motherboard page](#) for links to the Quick Reference Guide, User Manual, validated storage drives, etc.

#### ***Direct Links for General Support and Information***

[Frequently Asked Questions](#)

[Add-on Card Descriptions](#)

[TPM User Guide](#)

[BMC User Guide](#)

For validated memory, use our [Product Resources page](#).

### Direct Links (continued)

[Product Matrices](#) page for links to tables summarizing specs for systems, motherboards, power supplies, riser cards, add-on cards, etc.

[Security Center](#) for recent security notices

[Supermicro Phone and Addresses](#)

## 7.2 Baseboard Management Controller (BMC)

The system supports the Baseboard Management Controller (BMC). BMC is used to provide remote access, monitoring, and management. There are several BIOS settings that are related to BMC.

For general documentation and information on BMC, please visit our website at: [https://www.supermicro.com/manuals/other/BMC\\_IPMI\\_X13\\_H13.pdf](https://www.supermicro.com/manuals/other/BMC_IPMI_X13_H13.pdf)

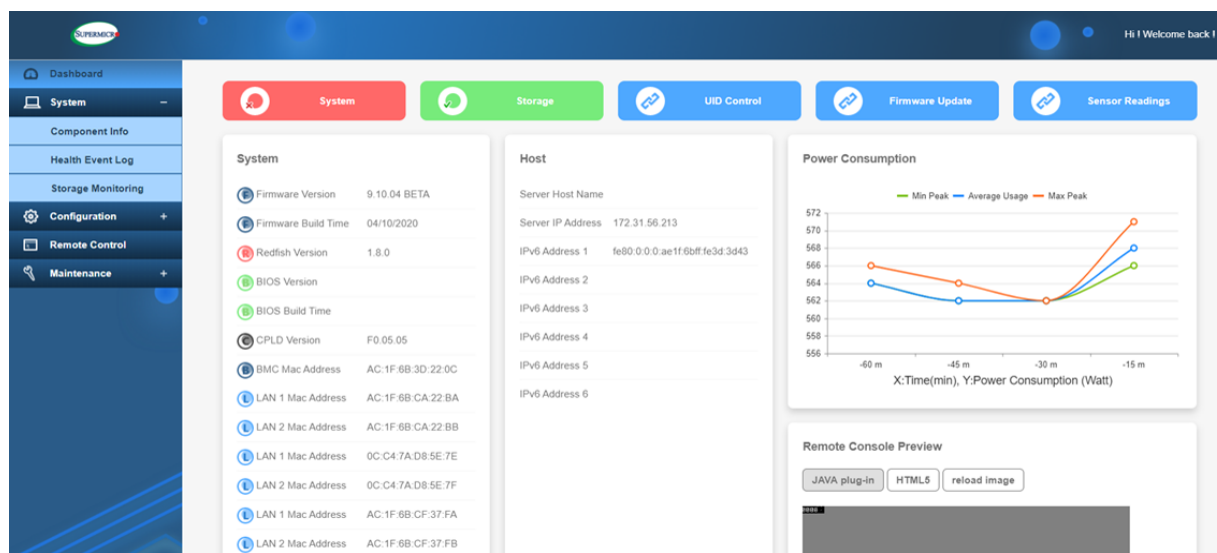

Figure 7-2. BMC Dashboard

## 7.3 Crash Dump Using the BMC Dashboard

In the event of a processor internal error (IERR) that crashes your system, you may want to provide information to support staff. You can download a crash dump of status information using the BMC Dashboard. The BMC manual is available at [https://www.supermicro.com/manuals/other/BMC\\_IPMI\\_X13\\_H13.pdf](https://www.supermicro.com/manuals/other/BMC_IPMI_X13_H13.pdf).

### Check Error Log

1. Access the BMC web interface.
2. Click the **Server Health** tab, then **Event Log** to verify an IERR error.

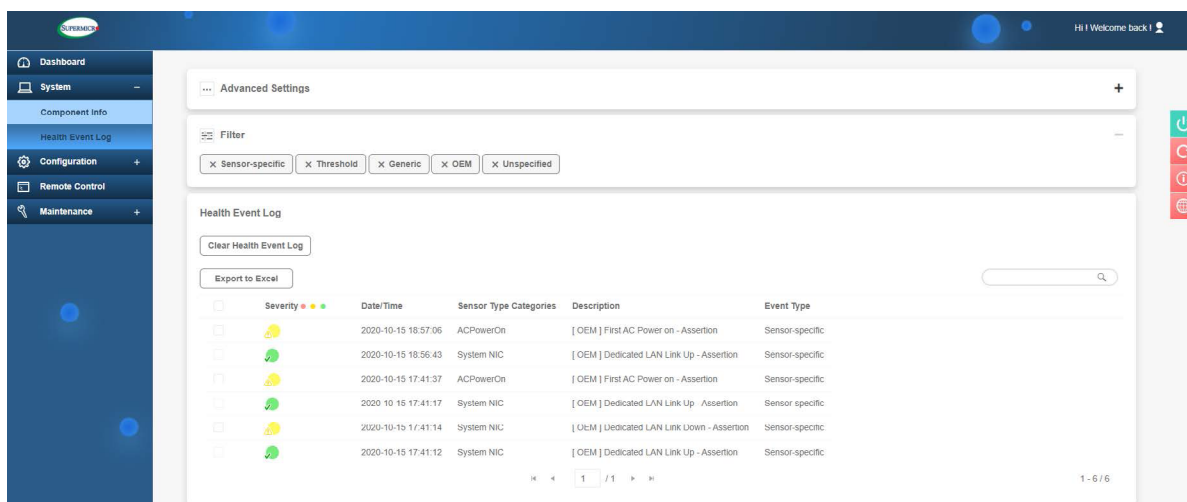

Figure 7-3. BMC Event Log

In the event of an IERR, the BMC executes a crash dump. You must download the crash dump and save it.

## 7.4 CMOS Clear

JBT1 is used to clear CMOS, which will also clear any passwords. Instead of pins, this jumper consists of contact pads to prevent accidentally clearing the contents of CMOS.

### **To Clear CMOS**

1. First power down the system and unplug the power cord(s).
2. Remove the cover of the chassis to access the motherboard and remove the battery from the motherboard.
3. Short the CMOS pads, JBT1, with a metal object such as a small screwdriver for at least four seconds.
4. Remove the screwdriver (or shorting device).
5. Replace the cover, reconnect the power cord(s), and power on the system.

**Note 1:** Clearing CMOS will also clear all passwords.

**Note 2:** Do not use the PW\_ON connector to clear CMOS.

## 7.5 BMC Reset

The BMC can be reset using the UID button.

- Reset – Press and hold the UID button. After six seconds, the LED blinks at 2 Hz. The BMC resets and the reset duration is approximately 250 ms. Then the BMC starts to boot.
- Restore factory default configuration – Hold the UID button for twelve seconds. The LED blinks at 4 Hz while defaults are configured. **Note:** All BMC settings including username and password will be removed except the FRU and network settings.

Firmware update – When the BMC firmware is being updated, the UID LED blinks at 10 Hz.

BMC Reset Options		
Event	UID LED	BMC Heartbeat LED
Reset	Blue, Blinks at 2 Hz	Green, solid
Restore Defaults	Blue, Blinks at 4 Hz	Off
Update	Blue, Blinks at 10 Hz	

## 7.6 Where to Get Replacement Components

If you need replacement parts for your system, to ensure the highest level of professional service and technical support, purchase exclusively from our Supermicro Authorized Distributors/System Integrators/Resellers. A list can be found at: <http://www.supermicro.com/>. Click the "Where to Buy" tab.

## 7.7 Reporting an Issue

### Technical Support Procedures

Before contacting Technical Support, please take the following steps. Also, please note that as a motherboard manufacturer, Supermicro also sells motherboards through its channels, so it is best to first check with your distributor or reseller for troubleshooting services. They should know of any possible problems with the specific system configuration that was sold to you.

1. Please go through the Troubleshooting Procedures and Frequently Asked Questions (FAQ) sections in this chapter or see the FAQs on our website (<http://www.supermicro.com/FAQ/index.php>) before contacting Technical Support.
2. BIOS upgrades can be downloaded from our website ([http://www.supermicro.com/ResourceApps/BIOS\\_BMC\\_Intel.html](http://www.supermicro.com/ResourceApps/BIOS_BMC_Intel.html)).
3. If you still cannot resolve the problem, include the following information when contacting Supermicro for technical support:
  - System, motherboard, and chassis model numbers and PCB revision number
  - BIOS release date/version (This can be seen on the initial display when your system first boots up.)
  - System configuration

An example of a Technical Support form is on our website at <http://www.supermicro.com/RmaForm/>. **Distributors:** For immediate assistance, please have your account number ready when placing a call to our Technical Support department. We can be reached by email at [support@supermicro.com](mailto:support@supermicro.com).

## Returning Merchandise for Service

A receipt or copy of your invoice marked with the date of purchase is required before any warranty service will be rendered. You can obtain service by calling your vendor for a Returned Merchandise Authorization (RMA) number. When returning to the manufacturer, the RMA number should be prominently displayed on the outside of the shipping carton, and mailed prepaid or hand-carried. Shipping and handling charges will be applied for all orders that must be mailed when service is complete.

For faster service, RMA authorizations may be requested online (<http://www.supermicro.com/support/rma/>).

This warranty only covers normal consumer use and does not cover damages incurred in shipping or from failure due to the alternation, misuse, abuse or improper maintenance of products.

During the warranty period, contact your distributor first for any product problems.

## Vendor Support Filing System

For issues related to Intel, use the Intel IPS filing system:

<https://www.intel.com/content/www/us/en/design/support/ips/training/welcome.html>

For issues related to Red Hat Enterprise Linux, since it is a subscription based OS, contact your account representative.

## 7.8 Feedback

Supermicro values your feedback as we strive to improve our customer experience in all facets of our business. Please email us at [techwriterteam@supermicro.com](mailto:techwriterteam@supermicro.com) to provide feedback on our manuals.

## 7.9 Contacting Supermicro

### Headquarters

Address: Super Micro Computer, Inc.  
980 Rock Ave.  
San Jose, CA 95131 U.S.A.

Tel: +1 (408) 503-8000

Fax: +1 (408) 503-8008

Email: [marketing@supermicro.com](mailto:marketing@supermicro.com) (General Information)  
[Sales-USA@supermicro.com](mailto:Sales-USA@supermicro.com) (Sales Inquiries)  
[Government\\_Sales-USA@supermicro.com](mailto:Government_Sales-USA@supermicro.com) (Gov. Sales Inquiries)  
[support@supermicro.com](mailto:support@supermicro.com) (Technical Support)  
[RMA@supermicro.com](mailto:RMA@supermicro.com) (RMA Support)  
[Webmaster@supermicro.com](mailto:Webmaster@supermicro.com) (Webmaster)

Website: [www.supermicro.com](http://www.supermicro.com)

### Europe

Address: Super Micro Computer B.V.  
Het Sterrenbeeld 28, 5215 ML  
's-Hertogenbosch, The Netherlands

Tel: +31 (0) 73-6400390

Fax: +31 (0) 73-6416525

Email: [Sales\\_Europe@supermicro.com](mailto:Sales_Europe@supermicro.com) (Sales Inquiries)  
[Support\\_Europe@supermicro.com](mailto:Support_Europe@supermicro.com) (Technical Support)  
[RMA\\_Europe@supermicro.com](mailto:RMA_Europe@supermicro.com) (RMA Support)

Website: [www.supermicro.nl](http://www.supermicro.nl)

### Asia-Pacific

Address: Super Micro Computer, Inc.  
3F, No. 150, Jian 1st Rd.  
Zhonghe Dist., New Taipei City 235  
Taiwan (R.O.C)

Tel: +886-(2) 8226-3990

Fax: +886-(2) 8226-3992

Email: [Sales-Asia@supermicro.com.tw](mailto:Sales-Asia@supermicro.com.tw) (Sales Inquiries)  
[Support@supermicro.com.tw](mailto:Support@supermicro.com.tw) (Technical Support)  
[RMA@supermicro.com.tw](mailto:RMA@supermicro.com.tw) (RMA Support)

Website: [www.supermicro.com.tw](http://www.supermicro.com.tw)

## Appendix A

# Standardized Warning Statements for AC Systems

## About Standardized Warning Statements

The following statements are industry standard warnings, provided to warn the user of situations which have the potential for bodily injury. Should you have questions or experience difficulty, contact Supermicro's Technical Support department for assistance. Only certified technicians should attempt to install or configure components.

Read this appendix in its entirety before installing or configuring components in the Supermicro chassis.

These warnings may also be found on our website at [http://www.supermicro.com/about/policies/safety\\_information.cfm](http://www.supermicro.com/about/policies/safety_information.cfm).

## Warning Definition



**Warning!** This warning symbol means danger. You are in a situation that could cause bodily injury. Before you work on any equipment, be aware of the hazards involved with electrical circuitry and be familiar with standard practices for preventing accidents.

### 警告の定義

この警告サインは危険を意味します。

人身事故につながる可能性がありますので、いずれの機器でも動作させる前に、電気回路に含まれる危険性に注意して、標準的な事故防止策に精通して下さい。

此警告符号代表危險。

您正处于可能受到严重伤害的工作环境中。在您使用设备开始工作之前，必须充分意识到触电的危险，并熟练掌握防止事故发生的标准工作程序。请根据每项警告结尾的声明号码找到此设备的安全性警告说明的翻译文本。

此警告符號代表危險。

您正處於可能身體可能會受損傷的工作環境中。在您使用任何設備之前，請注意觸電的危險，並且要熟悉預防事故發生的標準工作程序。請依照每一注意事項後的號碼找到相關的翻譯說明內容。

## Warnung

### WICHTIGE SICHERHEITSHINWEISE

Dieses Warnsymbol bedeutet Gefahr. Sie befinden sich in einer Situation, die zu Verletzungen führen kann. Machen Sie sich vor der Arbeit mit Geräten mit den Gefahren elektrischer Schaltungen und den üblichen Verfahren zur Vorbeugung vor Unfällen vertraut. Suchen Sie mit der am Ende jeder Warnung angegebenen Anweisungsnummer nach der jeweiligen Übersetzung in den übersetzten Sicherheitshinweisen, die zusammen mit diesem Gerät ausgeliefert wurden.

BEWAHREN SIE DIESE HINWEISE GUT AUF.

### INSTRUCCIONES IMPORTANTES DE SEGURIDAD

Este símbolo de aviso indica peligro. Existe riesgo para su integridad física. Antes de manipular cualquier equipo, considere los riesgos de la corriente eléctrica y familiarícese con los procedimientos estándar de prevención de accidentes. Al final de cada advertencia encontrará el número que le ayudará a encontrar el texto traducido en el apartado de traducciones que acompaña a este dispositivo.

GUARDE ESTAS INSTRUCCIONES.

### IMPORTANTES INFORMATIONS DE SÉCURITÉ

Ce symbole d'avertissement indique un danger. Vous vous trouvez dans une situation pouvant entraîner des blessures ou des dommages corporels. Avant de travailler sur un équipement, soyez conscient des dangers liés aux circuits électriques et familiarisez-vous avec les procédures couramment utilisées pour éviter les accidents. Pour prendre connaissance des traductions des avertissements figurant dans les consignes de sécurité traduites qui accompagnent cet appareil, référez-vous au numéro de l'instruction situé à la fin de chaque avertissement.

CONSERVEZ CES INFORMATIONS.

## תקנון הזהרות אזהרה

הזהרות הבאות הן אזהרות על פי תקני התעשייה, על מנת להזהיר את המשתמש מפני חבלה פיזית אפשרית. במידה ויש שאלות או היתקלות בבעיה כלשהי, יש ליצור קשר עם מחלקת תמיכה טכנית של סופרמיקרו. טכנאים מוסמכים בלבד רשאים להתקין או להגדיר את הרכיבים. יש לקרוא את הנספח במלואו לפני התקנת או הגדרת הרכיבים במארזי סופרמיקרו.

اَكْ ف حالة وُكِي اَي تتسبب ف اصابة جسدهُ هذا الزهز عُ خطر! تحذُرُ .  
 قبل اَي تعول على اَي هعدات، كي على علن بالوخاطز ال اُجوة عي الذوائر  
 الكهزبائِة  
 وكي على دراةُ بالووارسات النقاائِة لو عُ وقع اَي حادث  
 استخدم رقن الب اِي الو صُص ف هَّاةُ كل تحذُرُ للعشر تزجوتها

안전을 위한 주의사항

경고!

이 경고 기호는 위험이 있음을 알려 줍니다. 작업자의 신체에 부상을 야기 할 수 있는 상태에 있게 됩니다. 모든 장비에 대한 작업을 수행하기 전에 전기회로와 관련된 위험요소들을 확인하시고 사전에 사고를 방지할 수 있도록 표준 작업절차를 준수해 주시기 바랍니다.

해당 번역문을 찾기 위해 각 경고의 마지막 부분에 제공된 경고문 번호를 참조하십시오

## BELANGRIJKE VEILIGHEIDSINSTRUCTIES

Dit waarschuwings symbool betekent gevaar. U verkeert in een situatie die lichamelijk letsel kan veroorzaken. Voordat u aan enige apparatuur gaat werken, dient u zich bewust te zijn van de bij een elektrische installatie betrokken risico's en dient u op de hoogte te zijn van de standaard procedures om ongelukken te voorkomen. Gebruik de nummers aan het eind van elke waarschuwing om deze te herleiden naar de desbetreffende locatie.

BEWAAR DEZE INSTRUCTIES

## Installation Instructions



**Warning!** Read the installation instructions before connecting the system to the power source.

設置手順書

システムを電源に接続する前に、設置手順書をお読み下さい。

警告

将此系统连接电源前,请先阅读安装说明。

警告

將系統與電源連接前，請先閱讀安裝說明。

**Warnung**

Vor dem Anschließen des Systems an die Stromquelle die Installationsanweisungen lesen.

**¡Advertencia!**

Lea las instrucciones de instalación antes de conectar el sistema a la red de alimentación.

**Attention**

Avant de brancher le système sur la source d'alimentation, consulter les directives d'installation.

יש לקרוא את הוראות התקנה לפני חיבור המערכת למקור מתח.

اقر إرشادات التركيب قبل توصيل النظام إلى مصدر للطاقة

시스템을 전원에 연결하기 전에 설치 안내를 읽어주십시오.

**Waarschuwing**

Raadpleeg de installatie-instructies voordat u het systeem op de voedingsbron aansluit.

**Circuit Breaker**

**Warning!** This product relies on the building's installation for short-circuit (overcurrent) protection. Ensure that the protective device is rated not greater than: 250 V, 20 A.

**サーキット・ブレーカー**

この製品は、短絡(過電流)保護装置がある建物での設置を前提としています。

保護装置の定格が250 V、20 Aを超えないことを確認下さい。

**警告**

此产品的短路(过载电流)保护由建筑物的供电系统提供,确保短路保护设备的额定电流不大于250V,20A。

**警告**

此產品的短路(過載電流)保護由建築物的供電系統提供,確保短路保護設備的額定電流不大於250V,20A。

**Warnung**

Dieses Produkt ist darauf angewiesen, dass im Gebäude ein Kurzschluss- bzw. Überstromschutz installiert ist. Stellen Sie sicher, dass der Nennwert der Schutzvorrichtung nicht mehr als: 250 V, 20 A beträgt.

**¡Advertencia!**

Este equipo utiliza el sistema de protección contra cortocircuitos (o sobrecorrientes) del edificio. Asegúrese de que el dispositivo de protección no sea superior a: 250 V, 20 A.

**Attention**

Pour ce qui est de la protection contre les courts-circuits (surtension), ce produit dépend de l'installation électrique du local. Vérifiez que le courant nominal du dispositif de protection n'est pas supérieur à :250 V, 20 A.

מוצר זה מסתמך על הגנה המותקנת במבנים למניעת קצר חשמלי. יש לוודא כי המכשיר המגן מפני הקצר החשמלי הוא לא יותר מ-250VDC, 20A

هذا المنتج يعتمد على معدات الحماية مه الدوائر القصيرة التي تم تثبيتها في المبنى  
تأكد من أن تقييم الجهاز الوقائي ليس أكثر من : 20A, 250V

**경고!**

이 제품은 전원의 단락(과전류)방지에 대해서 전적으로 건물의 관련 설비에 의존합니다. 보호장치의 정격이 반드시 250V(볼트), 20A(암페어)를 초과하지 않도록 해야 합니다.

**Waarschuwing**

Dit product is afhankelijk van de kortsluitbeveiliging (overspanning) van uw elektrische installatie. Controleer of het beveiligde apparaat niet groter gedimensioneerd is dan 250V, 20A.

## Power Disconnection Warning



**Warning!** The system must be disconnected from all sources of power and the power cord removed from the power supply module(s) before accessing the chassis interior to install or remove system components (except for hot-swap components).



### 電源切断の警告

システムコンポーネントの取り付けまたは取り外しのために、シャーシ内部にアクセスするには、システムの電源はすべてのソースから切断され、電源コードは電源モジュールから取り外す必要があります。

### 警告

在你打开机箱并安装或移除内部器件前,必须将系统完全断电,并移除电源线。

### 警告

在您打開機殼安裝或移除內部元件前，必須將系統完全斷電，並移除電源線。

### Warnung

Das System muss von allen Quellen der Energie und vom Netzanschlusskabel getrennt sein, das von den Spg.Versorgungsteilmodulen entfernt wird, bevor es auf den Chassisinnenraum zurückgreift, um Systemsbestandteile anzubringen oder zu entfernen.

### ¡Advertencia!

El sistema debe ser disconnected de todas las fuentes de energía y del cable eléctrico quitado de los módulos de fuente de alimentación antes de tener acceso el interior del chasis para instalar o para quitar componentes de sistema.

### Attention

Le système doit être débranché de toutes les sources de puissance ainsi que de son cordon d'alimentation secteur avant d'accéder à l'intérieur du chassis pour installer ou enlever des composants de système.

אזהרה מפני ניתוק חשמלי

אזהרה!

יש לנתק את המערכת מכל מקורות החשמל ויש להסיר את כבל החשמלי מהספק לפני גישה לחלק הפנימי של המארז לצורך התקנת או הסרת רכיבים.

يجب فصل انظاؤ من جميع مصادر انطاقت وإزانت سهك انكهرباء من وحدة امداد انطاقت قيم

انصل إلى امناطق انداخييت نههيكم نشييج أو إزانت مكناث الجهاز

경고!

시스템에 부품들을 장착하거나 제거하기 위해서는 새시 내부에 접근하기 전에 반드시 전원 공급장치로부터 연결되어있는 모든 전원과 전기코드를 분리해주어야 합니다.

Waarschuwing

Voordat u toegang neemt tot het binnenwerk van de behuizing voor het installeren of verwijderen van systeem onderdelen, dient u alle spanningsbronnen en alle stroomkabels aangesloten op de voeding(en) van de behuizing te verwijderen

## Equipment Installation



**Warning!** Only authorized personnel and qualified service persons should be allowed to install, replace, or service this equipment.

機器の設置

トレーニングを受け認定された人だけがこの装置の設置、交換、またはサービスを許可されています。

警告

只有经过培训且具有资格的人员才能进行此设备的安装、更换和维修。

警告

只有經過受訓且具資格人員才可安裝、更換與維修此設備。

Warnung

Nur autorisiertes Personal und qualifizierte Servicetechniker dürfen dieses Gerät installieren, austauschen oder warten..

¡Advertencia!

Sólo el personal autorizado y el personal de servicio calificado deben poder instalar, reemplazar o dar servicio a este equipo.

**Attention**

Seul le personnel autorisé et le personnel de maintenance qualifié doivent être autorisés à installer, remplacer ou entretenir cet équipement..

אזהרה!

יש לאפשר רק צוות מורשה ואנשי שירות מוסמכים להתקין, להחליף או לטפל בציוד זה.

ينبغي السماح فقط للموظفين المعتمدين وأفراد الخدمة المؤهلين بتركيب هذا الجهاز أو استبداله أو صيانته.

**경고!**

승인된 직원과 자격을 갖춘 서비스 담당자만이 이 장비를 설치, 교체 또는 서비스할 수 있습니다.

**Waarschuwing**

Alleen geautoriseerd personeel en gekwalificeerd onderhoudspersoneel mag deze apparatuur installeren, vervangen of onderhouden..

**Restricted Area**

**Warning!** This unit is intended for installation in restricted access areas. A restricted access area can be accessed only through the use of a special tool, lock and key, or other means of security. (This warning does not apply to workstations).

**アクセス制限区域**

このユニットは、アクセス制限区域に設置されることを想定しています。

アクセス制限区域は、特別なツール、鍵と錠前、その他のセキュリティの手段を用いてのみ出入りが可能です。

**警告**

此部件应安装在限制进出的场所，限制进出的场所指只能通过使用特殊工具、锁和钥匙或其它安全手段进出的场所。

**警告**

此裝置僅限安裝於進出管制區域，進出管制區域係指僅能以特殊工具、鎖頭及鑰匙或其他安全方式才能進入的區域。

**Warnung**

Diese Einheit ist zur Installation in Bereichen mit beschränktem Zutritt vorgesehen. Der Zutritt zu derartigen Bereichen ist nur mit einem Spezialwerkzeug, Schloss und Schlüssel oder einer sonstigen Sicherheitsvorkehrung möglich.

**¡Advertencia!**

Esta unidad ha sido diseñada para instalación en áreas de acceso restringido. Sólo puede obtenerse acceso a una de estas áreas mediante la utilización de una herramienta especial, cerradura con llave u otro medio de seguridad.

**Attention**

Cet appareil doit être installée dans des zones d'accès réservés. L'accès à une zone d'accès réservé n'est possible qu'en utilisant un outil spécial, un mécanisme de verrouillage et une clé, ou tout autre moyen de sécurité.

אזור עם גישה מוגבלת

אזהרה!

יש להתקין את היחידה באזורים שיש בהם הגבלת גישה. הגישה ניתנת בעזרת 'כלי אבטחה בלבד' (מפתח, מנעול וכד.).

تخصيص هذه انحدة نترك بُها ف مناطق محظورة تم .

،ممكن اننصل إن منطقت محظورة فقط من خلال استخذاو أداة خاصت أو أ وس هُت أخري نلالأمما ققم ومفتاح

**경고!**

이 장치는 접근이 제한된 구역에 설치하도록 되어있습니다. 특수도구, 잠금 장치 및 키, 또는 기타 보안 수단을 통해서만 접근 제한 구역에 들어갈 수 있습니다.

**Waarschuwing**

Dit apparaat is bedoeld voor installatie in gebieden met een beperkte toegang. Toegang tot dergelijke gebieden kunnen alleen verkregen worden door gebruik te maken van speciaal gereedschap, slot en sleutel of andere veiligheidsmaatregelen.

## Battery Handling



**CAUTION:** There is risk of explosion if the battery is replaced by an incorrect type. Replace the battery only with the same or equivalent type recommended by the manufacturer. Dispose of used batteries according to the manufacturer's instructions

### 電池の取り扱い

バッテリーを間違ったタイプに交換すると爆発の危険があります。交換する電池はメーカーが推奨する型、または同等のものを使用下さい。使用済電池は製造元の指示に従って処分して下さい。

### 警告

如果更换的电池类型不正确，则存在爆炸危险。请只使用同类电池或制造商推荐的功能相当的电池更换原有电池。请按制造商的说明处理废旧电池。

### 警告

如果更換的電池類型不正確，則有爆炸危險。請使用製造商建議之相同或功能相當的電池更換原有電池。請按照製造商的說明指示處理廢棄舊電池。

### WARNUNG

Es besteht Explosionsgefahr, wenn die Batterie durch einen falschen Typ ersetzt wird. Ersetzen Sie die Batterie nur durch den gleichen oder vom Hersteller empfohlenen Batterietyp. Entsorgen Sie die benutzten Batterien nach den Anweisungen des Herstellers.

### ATTENTION

Il existe un risque d'explosion si la batterie est remplacée par un type incorrect. Ne la remplacer que par une pile de type semblable ou équivalent, recommandée par le fabricant. Jeter les piles usagées conformément aux instructions du fabricant.

### ADVERTENCIA

Existe riesgo de explosión si la batería se reemplaza por un tipo incorrecto. Reemplazar la batería exclusivamente con el mismo tipo o el equivalente recomendado por el fabricante. Desechar las baterías gastadas según las instrucciones del fabricante.

אזהרה!

קיימת סכנת פיצוץ אם הסוללה תוחלף בסוג שגוי. יש להחליף את הסוללה בסוג התואם מחברת יצרן מומלצת. סילוק הסוללות המשומשות יש לבצע לפי הוראות היצרן.

هناك خطر الانفجار إذا تم استبدال البطارية بنوع غير صحيح.  
 اسحبذال البطارية  
 فقط بنفس النوع أو ما يعادلها مما أوصت به الشركة المصنعة  
 جخلص من البطاريات المسحمة وفقا لعمليات الشركة الصانعة

경고!

배터리를 잘못된 종류로 교체하면 폭발의 위험이 있습니다. 기존 배터리와 동일하거나 제조사에서 권장하는 동등한 종류의 배터리로만 교체해야 합니다. 제조사의 안내에 따라 사용된 배터리를 처리하여 주십시오.

#### WAARSCHUWING

Er bestaat explosiegevaar als de batterij wordt vervangen door een verkeerd type. Vervang de batterij slechts met hetzelfde of een equivalent type die door de fabrikant aanbevolen wordt. Gebruikte batterijen dienen overeenkomstig fabrieksvoorschriften afgevoerd te worden.

### Redundant Power Supplies



**Warning!** This unit might have more than one power supply connection. All connections must be removed to de-energize the unit.

冗長電源装置

このユニットは複数の電源装置が接続されている場合があります。

ユニットの電源を切るためには、すべての接続を取り外さなければなりません。

警告

此部件连接的电源可能不止一个，必须将所有电源断开才能停止给该部件供电。

警告

此装置连接的电源可能不只一个，必须切断所有电源才能停止对该装置的供电。

Warnung

Dieses Gerät kann mehr als eine Stromzufuhr haben. Um sicherzustellen, dass der Einheit kein Strom zugeführt wird, müssen alle Verbindungen entfernt werden.

## ¡Advertencia!

Puede que esta unidad tenga más de una conexión para fuentes de alimentación. Para cortar por completo el suministro de energía, deben desconectarse todas las conexiones.

## Attention

Cette unité peut avoir plus d'une connexion d'alimentation. Pour supprimer toute tension et tout courant électrique de l'unité, toutes les connexions d'alimentation doivent être débranchées.

אם קיים יותר מספק אחד

אזהרה!

ליחידה יש יותר מחיבור אחד של ספק. יש להסיר את כל החיבורים על מנת לרוקן את היחידה.

قد يكون لهذا الجهاز عدة اتصالات بوحدات امداد الطاقة .

يجب إزالة كافة الاتصالات لعسل الوحدة عن الكهرباء

## 경고!

이 장치에는 한 개 이상의 전원 공급 단자가 연결되어 있을 수 있습니다. 이 장치에 전원을 차단하기 위해서는 모든 연결 단자를 제거해야만 합니다.

## Waarschuwing

Deze eenheid kan meer dan één stroomtoevoeraansluiting bevatten. Alle aansluitingen dienen verwijderd te worden om het apparaat stroomloos te maken.

## Backplane Voltage



**Warning!** Hazardous voltage or energy is present on the backplane when the system is operating. Use caution when servicing.

バックプレーンの電圧

システムの稼働中は危険な電圧または電力が、バックプレーン上にかかっています。

修理する際には注意ください。

警告

当系统正在进行时，背板上有很危险的电压或能量，进行维修时务必小心。

警告

當系統正在進行時，背板上有危險的電壓或能量，進行維修時務必小心。

Warnung

Wenn das System in Betrieb ist, treten auf der Rückwandplatine gefährliche Spannungen oder Energien auf. Vorsicht bei der Wartung.

¡Advertencia!

Cuando el sistema está en funcionamiento, el voltaje del plano trasero es peligroso. Tenga cuidado cuando lo revise.

Attention

Lorsque le système est en fonctionnement, des tensions électriques circulent sur le fond de panier. Prendre des précautions lors de la maintenance.

מתח בפנל האחורי

אזהרה!

קיימת סכנת מתח בפנל האחורי בזמן תפעול המערכת. יש להיזהר במהלך העבודה.

هناك خطر من التيار الكهربائي أو الطاقة المتجددة على اللوحة  
عندما يكون النظام يعمل كه حذرا عند خدمة هذا الجهاز

경고!

시스템이 동작 중일 때 후면판 (Backplane)에는 위험한 전압이나 에너지가 발생 합니다.  
서비스 작업 시 주의하십시오.

Waarschuwing

Een gevaarlijke spanning of energie is aanwezig op de backplane wanneer het systeem in gebruik is. Voorzichtigheid is geboden tijdens het onderhoud.

## Comply with Local and National Electrical Codes



**Warning!** Installation of the equipment must comply with local and national electrical codes.

地方および国の電気規格に準拠

機器の取り付けはその地方および国の電気規格に準拠する必要があります。

警告

设备安装必须符合本地与本国电气法规。

警告

設備安裝必須符合本地與本國電氣法規。

Warnung

Die Installation der Geräte muss den Sicherheitsstandards entsprechen.

¡Advertencia!

La instalación del equipo debe cumplir con las normas de electricidad locales y nacionales.

Attention

L'équipement doit être installé conformément aux normes électriques nationales et locales.

תיאום חוקי החשמל הארצי  
אזהרה!  
התקנת הציוד חייבת להיות תואמת לחוקי החשמל המקומיים והארציים.

تركيب المعدات الكهربائية يجب أن يمتثل للقوايه المحلية والبطية المتعلقة  
بالكهرباء

경고!

현 지역 및 국가의 전기 규정에 따라 장비를 설치해야 합니다.

Waarschuwing

Bij installatie van de apparatuur moet worden voldaan aan de lokale en nationale elektriciteitsvoorschriften.

## Product Disposal



**Warning!** Ultimate disposal of this product should be handled according to all national laws and regulations.

製品の廃棄

この製品を廃棄処分する場合、国の関係する全ての法律・条例に従い処理する必要があります。

警告

本产品的废弃处理应根据所有国家的法律和规章进行。

警告

本產品的廢棄處理應根據所有國家的法律和規章進行。

Warnung

Die Entsorgung dieses Produkts sollte gemäß allen Bestimmungen und Gesetzen des Landes erfolgen.

¡Advertencia!

Al deshacerse por completo de este producto debe seguir todas las leyes y reglamentos nacionales.

## Attention

La mise au rebut ou le recyclage de ce produit sont généralement soumis à des lois et/ou directives de respect de l'environnement. Renseignez-vous auprès de l'organisme compétent.

סילוק המוצר

אזהרה!

סילוק סופי של מוצר זה חייב להיות בהתאם להנחיות וחוקי המדינה.

التخلص النهائي من هذا المنتج ينبغي التعامل معه وفقا لجميع القوانين واللوائح الوطنية عند

## 경고!

이 제품은 해당 국가의 관련 법규 및 규정에 따라 폐기되어야 합니다.

## Waarschuwing

De uiteindelijke verwijdering van dit product dient te geschieden in overeenstemming met alle nationale wetten en reglementen.

## Fan Warning



**Warning!** Hazardous moving parts. Keep away from moving fan blades. The fans might still be turning when you remove the fan assembly from the chassis. Keep fingers, screwdrivers, and other objects away from the openings in the fan assembly's housing.

## ファンの警告

警告!回転部品に注意。運転中は回転部(羽根)に触れないでください。シャーシから冷却ファン装置を取り外した際、ファンがまだ回転している可能性があります。ファンの開口部に、指、ドライバー、およびその他のものを近づけないで下さい。

## 警告!

警告! 危險的可移動性零件。請務必與轉動的风扇叶片保持距離。當您從機架移除風扇裝置，風扇可能仍在轉動。小心不要將手指、螺絲起子和其他物品太靠近風扇

## 警告

危險的可移動性零件。請務必與轉動的风扇叶片保持距離。當您從機架移除風扇裝置，風扇可能仍在轉動。小心不要將手指、螺絲起子和其他物品太靠近風扇。

**Warnung**

Gefährlich Bewegende Teile. Von den bewegenden Lüfterblätter fern halten. Die Lüfter drehen sich u. U. noch, wenn die Lüfterbaugruppe aus dem Chassis genommen wird. Halten Sie Finger, Schraubendreher und andere Gegenstände von den Öffnungen des Lüftergehäuses entfernt.

**¡Advertencia!**

Riesgo de piezas móviles. Mantener alejado de las aspas del ventilador. Los ventiladores podran dar vuelta cuando usted quite el montaje del ventilador del chasis. Mantenga los dedos, los destornilladores y todos los objetos lejos de las aberturas del ventilador

**Attention**

Pieces mobiles dangereuses. Se tenir a l'écart des lames du ventilateur Il est possible que les ventilateurs soient toujours en rotation lorsque vous retirerez le bloc ventilateur du châssis. Prenez garde à ce que doigts, tournevis et autres objets soient éloignés du logement du bloc ventilateur.

**אזהרה!**

חלקים נעים מסוכנים. התרחק מלהבי המאוורר בפעולה כאשר מסירים את חלקי המאוורר מהמארז, יתכן והמאווררים עדיין עובדים. יש להרחיק למרחק בטוח את האצבעות וכלי עבודה שונים מהפתחים בתוך המאוורר

تحذير! أجزاء متحركة خطيرة. ابتعد عن شفرات المروحة المتحركة. من الممكن أن المراوح لا تزال تدور عند إزالة كتلة المروحة من الهيكل يجب إبقاء الأصابع ومفكات البراغي وغيرها من الأشياء بعيدا عن الفتحات في كتلة المروحة.

**경고!**

움직이는 위험한 부품. 회전하는 송풍 날개에 접근하지 마세요. 새시로부터 팬 조립품을 제거할 때 팬은 여전히 회전하고 있을 수 있습니다. 팬 조립품 외관의 열려있는 부분들로부터 손가락 및 스크류드라이버, 다른 물체들이 가까이 하지 않도록 배치해 주십시오.

**Waarschuwing**

Gevaarlijk bewegende onderdelen. Houd voldoende afstand tot de bewegende ventilatorbladen. Het is mogelijk dat de ventilator nog draait tijdens het verwijderen van het ventilatorsamenstel uit het chassis. Houd uw vingers, schroevendraaiers en eventuele andere voorwerpen uit de buurt van de openingen in de ventilatorbehuizing.

## Power Cable and AC Adapter



**Warning!** When installing the product, use the provided or designated connection cables, power cables and AC adapters. Using any other cables and adapters could cause a malfunction or a fire. Electrical Appliance and Material Safety Law prohibits the use of UL or CSA -certified cables (that have UL/CSA shown on the cord) for any other electrical devices than products designated by Supermicro only.

### 電源コードとACアダプター

製品を設置する場合、提供または指定および購入された接続ケーブル、電源コードとACアダプターを該当する地域の条例や安全基準に適合するコードサイズやプラグと共に使用下さい。他のケーブルやアダプタを使用すると故障や火災の原因になることがあります。

電気用品安全法は、ULまたはCSA認定のケーブル(UL/CSAマークがコードに表記)を Supermicro が指定する製品以外に使用することを禁止しています。

### 警告

安装此产品时,请使用本身提供的或指定的或采购的连接线,电源线和电源适配器。包含遵照当地法规和安全要求的合规的电源线尺寸和插头。使用其它线材或适配器可能会引起故障或火灾。除了Supermicro所指定的产品,电气用品和材料安全法律规定禁止使用未经UL或CSA认证的线材。(线材上会显示UL/CSA符号)。

### 警告

安裝此產品時,請使用本身提供的或指定的或採購的連接線,電源線和電源適配器。包含遵照當地法規和安全要求的合規的電源線尺寸和插頭。使用其它線材或適配器可能會引起故障或火災。除了Supermicro所指定的產品,電氣用品和材料安全法律規定禁止使用未經UL或CSA認證的線材。(線材上會顯示UL/CSA符號)。

### Warnung

Nutzen Sie beim Installieren des Produkts ausschließlich die von uns zur Verfügung gestellten Verbindungskabeln, Stromkabeln und/oder Adapter, die Ihre örtlichen Sicherheitsstandards einhalten. Der Gebrauch von anderen Kabeln und Adapter können Fehlfunktionen oder Feuer verursachen. Die Richtlinien untersagen das Nutzen von UL oder CAS zertifizierten Kabeln (mit UL/CSA gekennzeichnet), an Geräten oder Produkten die nicht mit Supermicro gekennzeichnet sind.

## ¡Advertencia!

Cuando instale el producto, utilice la conexión provista o designada o procure cables, Cables de alimentación y adaptadores de CA que cumplan con los códigos locales y los requisitos de seguridad, incluyendo el tamaño adecuado del cable y el enchufe. El uso de otros cables y adaptadores podría causar un mal funcionamiento o un incendio. La Ley de Seguridad de Aparatos Eléctricos y de Materiales prohíbe El uso de cables certificados por UL o CSA (que tienen el certificado UL / CSA en el código) para cualquier otros dispositivos eléctricos que los productos designados únicamente por Supermicro.

## Attention

Lors de l'installation du produit, utilisez les cables de connection fournis ou désigné ou achetez des cables, cables de puissance et adaptateurs respectant les normes locales et les conditions de securite y compris les tailles de cables et les prises electriques appropries. L'utilisation d'autres cables et adaptateurs peut provoquer un dysfonctionnement ou un incendie. Appareils électroménagers et la Loi sur la Sécurité Matériel interdit l'utilisation de câbles certifiés- UL ou CSA (qui ont UL ou CSA indiqué sur le code) pour tous les autres appareils électriques sauf les produits désignés par Supermicro seulement.

AC ימאתמו מילמשח מילבכ

!הרהזא

ךרוצל ומאתוה וא ושכרנ רשא AC מילמשח מילבכ, מילבכב שמתשהל שי, רצומה תא מיניקתמ רשאכ לכב שומיש . עקתהו לבכה לש הנוכח הדימ ללוכ, תוימוקמה תוחיטבה תושירדל ומאתוה רשאו, הנקתהה למשחה ירישכמב שומישה יקוחל מאתהב. ילמשח רצק וא הלקתל מורגל לולע, רחא גוסמ מאתמ וא לבכ לש דוק מהילע עיפומ רשאכ) UL-ב או CSA-ב (ב-מילמשח מילבכב שמתשהל רוסיא מייק, תוחיטבה יקוחו דבלב Supermicro י"ע מאתוה רשא רצומב קר אלא, רחא ילמשח רצומ לכ רובע UL/CSA)

תאלבאלא אארשב מץ וא אדדחמלא וא ארפוטמלא תאלויסוולא מלדחמלא מץ, אגתנמלא בייקרת דנע לכלז יפ אמב אילחמלא אמאלסלא תאלבאלמלא נילאווב מאזתלאל אמ דדרתמלא ראיטלא תאלוחמו אילברמלא קיירח וא לטע יפ בבסטטי דץ ירשא תאלוחמו תאלבאלא יא מלדחמלא. מילסלא סבאלאו ולסומלא מלחח CSA וא UL לבק נמ אדמלמלא תאלבאלא מלדחמלא אילברמלא אזהאלל אמאלסלא נונאק רלחחי Supermicro לבק נמ אדדחמלא אילמלא רייג ירשא תלדחמלא יא אמ (UL/CSA) אמאלע למחתיטלאו

### 전원 케이블 및 AC 어댑터

경고! 제품을 설치할 때 현지 코드 및 적절한 굵기의 코드와 플러그를 포함한 안전 요구 사항을 준수하여 제공되거나 지정된 연결 혹은 구매 케이블, 전원 케이블 및 AC 어댑터를 사용하십시오.

다른 케이블이나 어댑터를 사용하면 오작동이나 화재가 발생할 수 있습니다. 전기 용품 안전법은 UL 또는 CSA 인증 케이블 (코드에 UL / CSA가 표시된 케이블)을 Supermicro 가 지정한 제품 이외의 전기 장치에 사용하는 것을 금지합니다.

### Stroomkabel en AC-Adapter

Waarschuwing! Bij het aansluiten van het Product uitsluitend gebruik maken van de geleverde Kabels of een andere geschikte aan te schaffen Aansluitmethode, deze moet altijd voldoen aan de lokale voorschriften en veiligheidsnormen, inclusief de juiste kabeldikte en stekker. Het gebruik van niet geschikte Kabels en/of Adapters kan een storing of brand veroorzaken. Wetgeving voor Elektrische apparatuur en Materiaalveiligheid verbied het gebruik van UL of CSA -gecertificeerde Kabels (met UL/CSA in de code) voor elke andere toepassing dan de door Supermicro hiervoor beoogde Producten.

# Appendix B

## System Specifications

### Processors

NVIDIA Grace™ CPU Superchip via four Mirror Mezz connectors

**Note:** Refer to the motherboard specifications pages on our website for updates to supported processors.

### Chipset

System on Chip

### BIOS

256 Mb SPI AMI BIOS® SM Flash UEFI BIOS

ACPI 6.4, SMBIOS 3.5.0, Plug-and-Play (PnP), RTC (Real Time Clock) wakeup, Riser Card Auto-Detection Support

### Memory

Embedded 480 GB ECC LPDDR5 with up to 500 GB/s throughput

96 GB of HBM3 memory with up to 4 TB/s of memory bandwidth

### Storage Drives

Two M.2 NVMe SSDs

(M.2 is not recommended to be used as storage drive. It is recommended to be used as an OS boot drive.)

Eight E1.S hot-swap NVMe storage drives (Four are default, additional four are optional)

### PCI Expansion Slots

Seven PCIe 5.0 x16 slots

(four FHFL/DW for GPU bays & three single-width FHFL for I/O bays)

### Input/Output

One 1 GbE RJ45 dedicated BMC LAN port

Two USB3.0 ports

One Mini DisplayPort

### Motherboard

G1SMH; 14" (W) x 10" (L) (355.6 x 254 mm)

### Chassis

CSE-GP201TS, 2U Rackmount, 438.4 x 88 x 900 mm (17.25" x 3.46" x 35.43")

### System Cooling

Six heavy-duty counter-rotating fans with optimal fan speed control

### Power Supply

Model: PWS-2K09F-1R, three redundant (2+1) 2000 W power supplies, 80Plus Titanium level

AC Input

1000 W: 100-127 Vac / 50-60 Hz

1800 W: 200-220 Vac / 50-60 Hz

1980 W: 220-230 Vac / 50-60 Hz

2000 W: 220-240 Vac / 50-60 Hz (for UL only)

2000 W: 230-240 Vac / 50-60 Hz

2000 W: 230-240 Vdc / 50-60 Hz (for CQC only)

+12V

Max: 83 A / Min: 0 A (100 Vac-127 Vac)

Max: 150 A / Min: 0 A (200 Vac-220 Vac)

Max: 165 A / Min: 0 A (220 Vac-230 Vac)

Max: 166 A / Min: 0 A (230 Vac-240 Vac)

12V SB

Max: 3.5 A / Min: 0 A

**Operating Environment**

Operating Temperature: 10°C to 35°C (50°F to 95°F)

Non-operating Temperature: -40°C to 60°C (-40°F to 140°F)

Operating Relative Humidity: 8% to 90% (non-condensing)

Non-operating Relative Humidity: 5% to 95% (non-condensing)

**Regulatory Compliance**

FCC, ICES, CE, VCCI, RCM, UKCA, NRTL, CB

**Applied Directives, Standards**

EMC/EMI: 2014/30/EU (EMC Directive)

Electromagnetic Compatibility Regulations 2016

FCC Part 15

ICES-003

VCCI-CISPR 32

AS/NZS CISPR 32

BS/EN55032

BS/EN55035

CISPR 32

CISPR 35

BS/EN 61000-3-2

BS/EN 61000-3-3

BS/EN 61000-4-2

BS/EN 61000-4-3

BS/EN 61000-4-4

BS/EN 61000-4-5

BS/EN 61000-4-6

BS/EN 61000-4-8

BS/EN 61000-4-11

Environment:

Delegated Directive (EU) 2015/863

Directive 2011/65/EU (RoHS)

REACH Regulation EC 1907/2006

WEEE Directive 2012/19/EU

California Proposition 65

Product Safety: 2014/35/EU (LVD Directive)

UL/CSA 62368-1 (USA and Canada)

Electrical Equipment (Safety) Regulations 2016

IEC/BS/EN 62368-1

**Warning!** This product can expose you to chemicals including lead, known to the State of California to cause cancer and birth defects or other reproductive harm. For more information, go to [www.P65Warnings.ca.gov](http://www.P65Warnings.ca.gov).

**Perchlorate Warning**

California Best Management Practices Regulations for Perchlorate Materials: This Perchlorate warning applies only to products containing CR (Manganese Dioxide) Lithium coin cells. "Perchlorate Material-special handling may apply.

See "[www.dtsc.ca.gov/hazardouswaste/perchlorate](http://www.dtsc.ca.gov/hazardouswaste/perchlorate)".

**General Data Center Environmental Specifications****Particulate contamination specifications**

Air filtration: Data centers must be kept clean to Class 8 of ISO 14644-1 (ISO 2015). The air entering the data center should be filtered with a MERV 11 filter or better. The air within the data center should be continuously filtered with a MERV 8 filter or better.

Conductive dust: Air should be free of conductive dust, zinc whiskers, or other conductive particles.

Corrosive dust: Air should be free of corrosive dust.

**Gaseous\* contamination specifications**

Copper coupon corrosion rate: <300 Å/month per class G1 as defined by ANSI/ISA71.04-2013, referenced by ASHRAE TC 9.9

Silver coupon corrosion rate: <200 Å/month per class G1 as defined by ANSI/ISA71.04-2013, referenced by ASHRAE TC 9.9

\*If testing with silver or copper coupons results in values less than 200 Å/month or 300 Å/month, respectively, then operating up to 70% relative humidity (RH) is acceptable. If the testing shows corrosion levels exceed these limits, then catalyst-type pollutants are probably present and RH should be driven to 50% or lower.

この装置は、クラスA機器です。この装置を住宅環境で使用すると電波妨害を引き起こすことがあります。この場合には使用者が適切な対策を講ずるよう要求されることがあります。

VCCI – A



**Warning!** This equipment must use a Laser Class 1 optical transceiver.