



# SuperServer<sup>®</sup> ARS-211ME-FNR



USER'S MANUAL

Revision 1.0

The information in this User's Manual has been carefully reviewed and is believed to be accurate. The vendor assumes no responsibility for any inaccuracies that may be contained in this document, and makes no commitment to update or to keep current the information in this manual, or to notify any person or organization of the updates. Please Note: For the most up-to-date version of this manual, please see our website at [www.supermicro.com](http://www.supermicro.com).

Super Micro Computer, Inc. ("Supermicro") reserves the right to make changes to the product described in this manual at any time and without notice. This product, including software and documentation, is the property of Supermicro and/or its licensors, and is supplied only under a license. Any use or reproduction of this product is not allowed, except as expressly permitted by the terms of said license.

IN NO EVENT WILL Super Micro Computer, Inc. BE LIABLE FOR DIRECT, INDIRECT, SPECIAL, INCIDENTAL, SPECULATIVE OR CONSEQUENTIAL DAMAGES ARISING FROM THE USE OR INABILITY TO USE THIS PRODUCT OR DOCUMENTATION, EVEN IF ADVISED OF THE POSSIBILITY OF SUCH DAMAGES. IN PARTICULAR, SUPER MICRO COMPUTER, INC. SHALL NOT HAVE LIABILITY FOR ANY HARDWARE, SOFTWARE, OR DATA STORED OR USED WITH THE PRODUCT, INCLUDING THE COSTS OF REPAIRING, REPLACING, INTEGRATING, INSTALLING OR RECOVERING SUCH HARDWARE, SOFTWARE, OR DATA.

Any disputes arising between manufacturer and customer shall be governed by the laws of Santa Clara County in the State of California, USA. The State of California, County of Santa Clara shall be the exclusive venue for the resolution of any such disputes. Supermicro's total liability for all claims will not exceed the price paid for the hardware product.

FCC Statement: This equipment has been tested and found to comply with the limits for a Class A or Class B digital device pursuant to Part 15 of the FCC Rules. These limits are designed to provide reasonable protection against harmful interference when the equipment is operated in industrial environment for Class A device or in residential environment for Class B device. This equipment generates, uses, and can radiate radio frequency energy and, if not installed and used in accordance with the manufacturer's instruction manual, may cause harmful interference with radio communications. Operation of this equipment in a residential area is likely to cause harmful interference, in which case you will be required to correct the interference at your own expense.

California Best Management Practices Regulations for Perchlorate Materials: This Perchlorate warning applies only to products containing CR (Manganese Dioxide) Lithium coin cells. "Perchlorate Material-special handling may apply. See [www.dtsc.ca.gov/hazardouswaste/perchlorate](http://www.dtsc.ca.gov/hazardouswaste/perchlorate)".



WARNING: This product can expose you to chemicals including lead, known to the State of California to cause cancer and birth defects or other reproductive harm. For more information, go to [www.P65Warnings.ca.gov](http://www.P65Warnings.ca.gov).

The products sold by Supermicro are not intended for and will not be used in life support systems, medical equipment, nuclear facilities or systems, aircraft, aircraft devices, aircraft/emergency communication devices or other critical systems whose failure to perform be reasonably expected to result in significant injury or loss of life or catastrophic property damage. Accordingly, Supermicro disclaims any and all liability, and should buyer use or sell such products for use in such ultra-hazardous applications, it does so entirely at its own risk. Furthermore, buyer agrees to fully indemnify, defend and hold Supermicro harmless for and against any and all claims, demands, actions, litigation, and proceedings of any kind arising out of or related to such ultra-hazardous use or sale.

Manual Revision 1.0

Release Date: March 21, 2025

Unless you request and receive written permission from Super Micro Computer, Inc., you may not copy any part of this document. Information in this document is subject to change without notice. Other products and companies referred to herein are trademarks or registered trademarks of their respective companies or mark holders.

Copyright © 2025 by Super Micro Computer, Inc.  
All rights reserved.

**Printed in the United States of America**

# Preface

## About this Manual

This manual is written for professional system integrators and PC technicians. It provides information for the installation and use of the server. Installation and maintenance should be performed by certified service technicians only.

Please refer to the ARS-211ME-FNR server specifications page on our website for updates on supported memory, processors, and operating systems (<http://www.supermicro.com>).

## Notes

For your system to work properly, please follow the links below to download all necessary drivers/utilities and the user's manual for your server.

- Supermicro product manuals: <http://www.supermicro.com/support/manuals/>
- Product drivers and utilities: <https://www.supermicro.com/wdl>
- Product safety info: [http://www.supermicro.com/about/policies/safety\\_information.cfm](http://www.supermicro.com/about/policies/safety_information.cfm)

If you have any questions, please contact our support team at:  
[support@supermicro.com](mailto:support@supermicro.com)

This manual may be periodically updated without notice. Please check the Supermicro website for possible updates to the manual revision level.

## Secure Data Deletion

A secure data deletion tool designed to fully erase all data from storage devices can be found on our website: [https://www.supermicro.com/about/policies/disclaimer.cfm?url=/wdl/utility/Log9\\_Secure\\_Data\\_Deletion\\_UTILITY/](https://www.supermicro.com/about/policies/disclaimer.cfm?url=/wdl/utility/Log9_Secure_Data_Deletion_UTILITY/)

## Warnings

Special attention should be given to the following symbols used in this manual.



**Warning!** Indicates important information given to prevent equipment/property damage or personal injury.



**Warning!** Indicates high voltage may be encountered when performing a procedure.

# Contents

Contacting Supermicro.....	8
<b>Chapter 1 Introduction</b>	
1.1 Overview.....	9
1.2 System Features .....	10
Front View .....	10
Drive Carrier Indicators.....	11
Control Panel .....	12
Rear View.....	13
Power Supply Indicator.....	13
1.3 System Architecture .....	14
Main Components .....	14
System Block Diagram.....	15
1.4 Motherboard Layout .....	16
Quick Reference Table.....	17
<b>Chapter 2 Server Installation</b>	
2.1 Overview.....	19
2.2 Unpacking the System .....	19
2.3 Preparing for Setup.....	19
Choosing a Setup Location.....	19
Rack Precautions .....	20
Server Precautions.....	20
Rack Mounting Considerations .....	20
Ambient Operating Temperature.....	20
Airflow .....	20
Mechanical Loading.....	21
Circuit Overloading .....	21
Reliable Ground.....	21
2.4 Installing the Rails .....	22
Identifying the Rails .....	22
Releasing the Inner Rail.....	23
Installing the Inner Rails .....	24
Installing the Outer Rails onto the Rack.....	25

---

---

2.5	Installing the Chassis into a Rack.....	26
	Removing the Chassis from the Rack .....	27
<b>Chapter 3 Maintenance and Component Installation</b>		
3.1	Removing Power .....	28
3.2	Accessing the System.....	29
3.3	Static-Sensitive Devices.....	30
	Precautions .....	30
	Unpacking .....	30
3.4	Processor and Heatsink Installation.....	31
	The AmpereOne Processor.....	31
	Overview of the Processor Socket.....	32
	Overview of the Heatsink.....	32
	Installing the Processor.....	33
	Installing the Heatsink.....	37
3.5	Motherboard Installation.....	39
	Tools Needed .....	39
	Location of Mounting Holes .....	39
	Installing the Motherboard.....	40
3.6	Memory Support and Installation .....	41
	Memory Support.....	41
	DIMM Module Population Configuration .....	41
	General Guidelines for Optimizing Memory Performance .....	42
	DIMM Installation .....	43
	DIMM Removal .....	43
3.7	Motherboard Battery.....	44
	Battery Removal.....	44
	Proper Battery Disposal .....	44
	Battery Installation.....	44
3.8	Storage Drives.....	45
	Drive Carrier Indicators .....	45
	Installing Drives.....	46
	Installing M.2 Solid State Drives .....	48
3.9	Expansion Cards .....	49
3.10	GPUs.....	50

---

---

---

3.11 System Cooling .....	52
System Fans .....	52
Air Shrouds .....	53
3.12 Power Supply .....	54
<b><i>Chapter 4 Motherboard Connections</i></b>	
4.1 Power Connections .....	55
4.2 Headers and Connectors .....	57
Front Control Panel .....	60
4.3 Input/Output Ports .....	63
4.4 Jumpers .....	66
Explanation of Jumpers.....	66
4.5 LED Indicators.....	68
<b><i>Chapter 5 Software</i></b>	
5.1 Ubuntu OS Installation .....	69
5.2 BMC.....	69
5.3 Logging into the BMC (Baseboard Management Controller) .....	69
<b><i>Chapter 6 Troubleshooting and Support</i></b>	
6.1 Information Resources .....	70
Website .....	70
Direct Links for the ARS-211ME-FNR System .....	70
Direct Links for General Support and Information .....	70
6.2 Troubleshooting Procedures .....	71
Before Power On .....	71
No Power .....	71
No Video .....	72
System Boot Failure .....	72
Memory Errors .....	72
Losing the System's Setup Configuration.....	73
If the System Becomes Unstable.....	73
6.3 Technical Support Procedures .....	74
6.4 Frequently Asked Questions .....	75
6.5 Returning Merchandise for Service.....	76
6.6 Feedback.....	76
6.7 Contacting Supermicro.....	77

*Appendix A Standardized Warning Statements for AC Systems*

*Appendix B System Specifications*

*Appendix C BIOS Codes*

*Appendix D Updating BIOS and BMC with OpenBMC WebGUI*

## Contacting Supermicro

### Headquarters

Address: Super Micro Computer, Inc.  
980 Rock Ave.  
San Jose, CA 95131 U.S.A.

Tel: +1 (408) 503-8000

Fax: +1 (408) 503-8008

Email: [marketing@supermicro.com](mailto:marketing@supermicro.com) (General Information)  
[Sales-USA@supermicro.com](mailto:Sales-USA@supermicro.com) (Sales Inquiries)  
[Government\\_Sales-USA@supermicro.com](mailto:Government_Sales-USA@supermicro.com) (Gov. Sales Inquiries)  
[support@supermicro.com](mailto:support@supermicro.com) (Technical Support)  
[RMA@supermicro.com](mailto:RMA@supermicro.com) (RMA Support)  
[Webmaster@supermicro.com](mailto:Webmaster@supermicro.com) (Webmaster)

Website: [www.supermicro.com](http://www.supermicro.com)

### Europe

Address: Super Micro Computer B.V.  
Het Sterrenbeeld 28, 5215 ML  
's-Hertogenbosch, The Netherlands

Tel: +31 (0) 73-6400390

Fax: +31 (0) 73-6416525

Email: [Sales\\_Europe@supermicro.com](mailto:Sales_Europe@supermicro.com) (Sales Inquiries)  
[Support\\_Europe@supermicro.com](mailto:Support_Europe@supermicro.com) (Technical Support)  
[RMA\\_Europe@supermicro.com](mailto:RMA_Europe@supermicro.com) (RMA Support)

Website: [www.supermicro.nl](http://www.supermicro.nl)

### Asia-Pacific

Address: Super Micro Computer, Inc.  
3F, No. 150, Jian 1st Rd.  
Zhonghe Dist., New Taipei City 235  
Taiwan (R.O.C)

Tel: +886-(2) 8226-3990

Fax: +886-(2) 8226-3992

Email: [Sales-Asia@supermicro.com.tw](mailto:Sales-Asia@supermicro.com.tw) (Sales Inquiries)  
[Support@supermicro.com.tw](mailto:Support@supermicro.com.tw) (Technical Support)  
[RMA@supermicro.com.tw](mailto:RMA@supermicro.com.tw) (RMA Support)

Website: [www.supermicro.com.tw](http://www.supermicro.com.tw)

# Chapter 1

## Introduction

### 1.1 Overview

This chapter provides a brief outline of the functions and features of the SuperServer ARS-211ME-FNR. It is based on the R13SPD motherboard and the CSE-LB23MTS-R000NDP chassis.

The following provides an overview of the specifications and capabilities of the system.

System Overview	
<b>Motherboard</b>	R13SPD
<b>Chassis</b>	CSE-LB23MTS-R000NDP
<b>Processor Support</b>	Supports an AmpereOne® processor with up to 192 cores and a TDP of up to 400 W in an LGA5964 socket
<b>Memory</b>	Supports up to 8 TB of DDR5-5600 ECC RDIMM/3DS RDIMM with speeds of up to 5200 MT/s in 16 memory slots (1R2DPC)
<b>Drive Support</b>	Six front hot-swap 2.5" NVMe drive bays One M.2 NVMe slot (M-key 22110)
<b>Expansion Slots</b>	Two PCIe 5.0 x8 slots: one FHFL, one FHHL Two PCIe 5.0 x16 slots: one FHFL, one FHHL One PCIe 5.0 x16 LP slot One PCIe 5.0 x16 AIOM slot (OCP 3.0 compatible)
<b>I/O Ports</b>	USB: Two front USB 3.0 ports COM: One COM port (serial) Video: One VGA port LAN: One RJ45 Dedicated IPMI LAN port Two 25 Gb SFP28 Ethernet ports
<b>System Cooling</b>	Four 8-cm heavy-duty fans
<b>Power</b>	Two redundant 1600 W power supply modules, PWS-1K62A-1R
<b>Form Factor</b>	2U Rackmount, 3.5" x 17.2" x 17" (88.9 x 436.88 x 431.8 mm) (H x W x D)

**Notes:** A Quick Reference Guide can be found on the product page of the Supermicro website. The following safety models associated with the ARS-211ME-FNR have been certified as compliant with UL or CSA: LB23MDC-R16R13 and LB23M-16.

## 1.2 System Features

The following views of the system display the main features. Refer to [Appendix B](#) for additional specifications.

### Front View

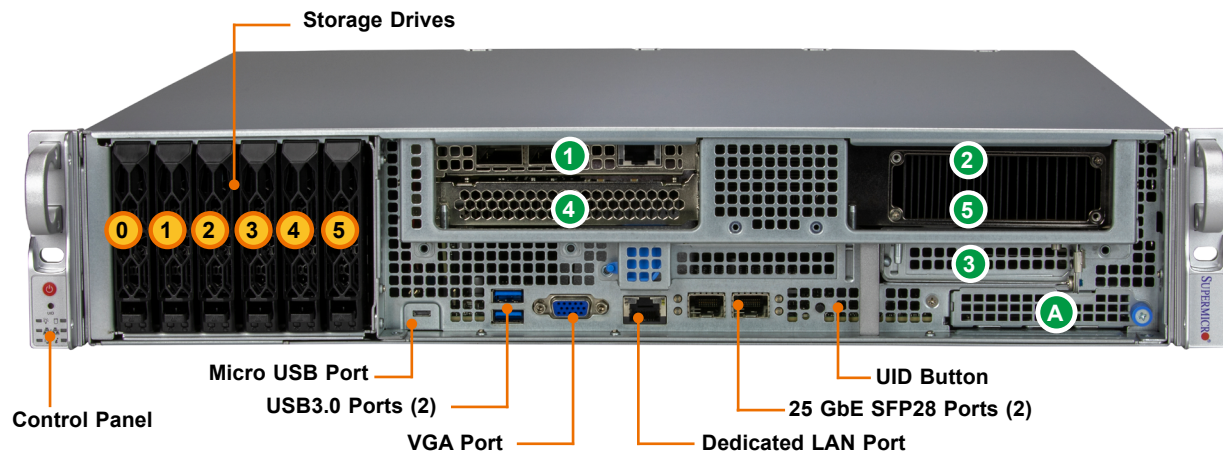

Figure 1-1. Front View

System Features: Front	
Feature	Description
0 to 5	Six front hot-swap 2.5" NVMe drive bays
Control Panel	Front control panel with LEDs and buttons (see the <a href="#">Control Panel</a> page)
USB Ports	Two front USB 3.0 ports
COM Port	One COM port (serial)
VGA	One VGA port
IPMI	One IPMI port (remote management)
LAN	One RJ45 Dedicated IPMI LAN port Two 25 Gb SFP28 Ethernet LAN ports
UID Button	One UID button

Expansion Slots	
Slot	Description
1	PCIe 5.0 x16 (FHHL)
2	PCIe 5.0 x16 DW GPU
3	PCIe 5.0 x16 (LP)
4	PCIe 5.0 x8 (FHHL)
5	PCIe 5.0 x8 (cannot be used if DW GPU installed in slot 2) (FHFL)
A	PCIe 5.0 x16 AIOM

### ***Drive Carrier Indicators***

Each drive carrier has two LED indicators: an activity indicator and a status indicator. For RAID configurations using a controller, the meaning of the status indicator is described in the table below. For OS RAID or non-RAID configurations, some LED indications are not supported, such as hot spare.

Drive Carrier LED Indicators			
	Color	Blinking Pattern	Behavior for Device
<b>Activity LED</b>	Blue	Solid On	Idle SAS drive installed
	Blue	Blinking	I/O activity
	Off		Idle SATA or no drive
<b>Status LED</b>	Red	Solid On	Failure of drive with RSTe support
	Red	Blinking at 1 Hz	Rebuild drive with RSTe support
	Red	Blinking at 4 Hz	Identify drive with RSTe support
	Red	Blinking with two blinks and one stop at 1 Hz	Hot spare for drive with RSTe support
	Red	On for five seconds, then off	Power on for drive with RSTe support

## Control Panel

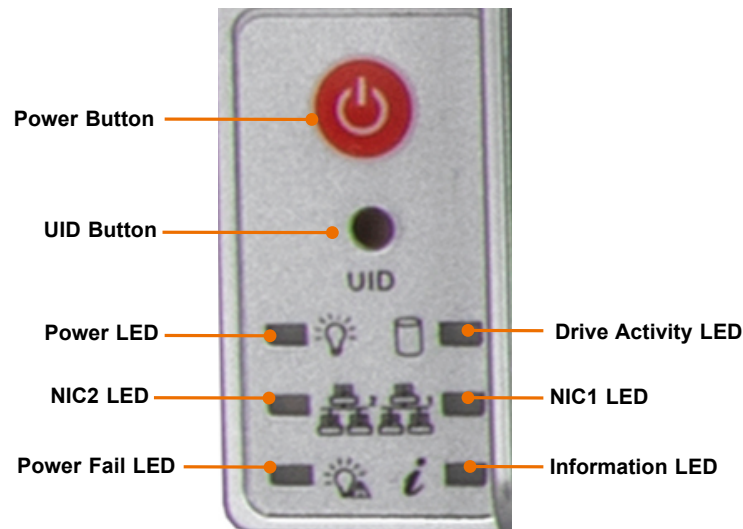

Figure 1-2. Control Panel

Control Panel Features	
Feature	Description
Power Button	The main power switch applies or removes primary power from the power supply to the server but maintains standby power.
UID LED	The unit identification (UID) LED turns on when activated by the UID button or via management software.
Power LED	Steady on – Power on Blinking at 4 Hz – Checking BIOS/BMC integrity Blinking at 4 Hz and "i" LED is blue – BIOS firmware updating Two blinks at 4 Hz, one pause 2 Hz and "i" LED blue – BMC firmware updating Blinking at 1 Hz and "i" LED red – Fault detected
NIC LEDs	Indicates network activity on LANs when flashing.
Power Fail LED	Indicates a power supply module has failed.
Drive Activity LED	Indicates network activity on storage drives when flashing.
Information LED	Alerts operator to several states, as noted in the table below.

Information LED	
Color, Status	Description
Red, solid	An overheat condition has occurred.
Red, blinking at 1 Hz	Fan failure, check for an inoperative fan.
Red, blinking at 0.25 Hz	Power failure, check for a non-operational power supply.
Blue, solid	UID has been activated locally to locate the server in a rack environment.
Blue, blinking at 1 Hz	UID has been activated using the BMC to locate the server in a rack environment.

## Rear View

The illustration below shows the features on the rear of the chassis.

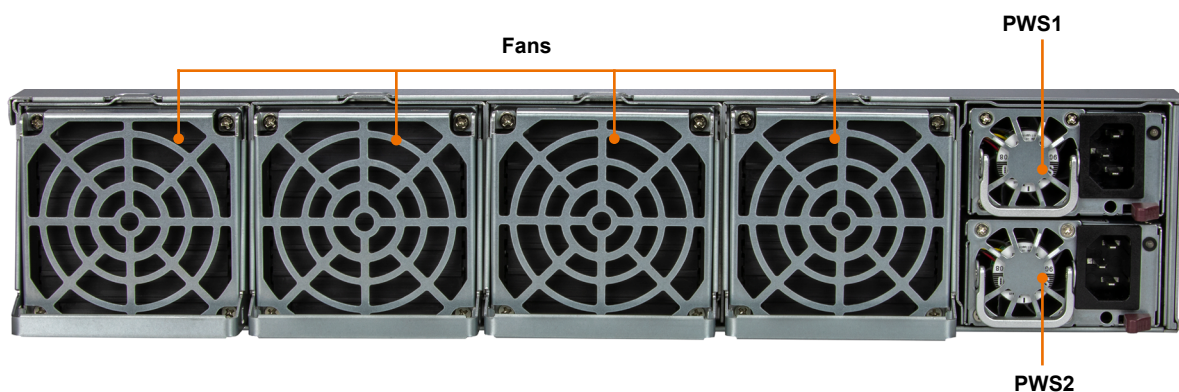

**Figure 1-3. System: Rear View**

System Features: Rear	
Feature	Description
Power Supplies	Two 1600 W Redundant (1 + 1) Titanium Level (96%) power supplies PWS1 on the top, PWS2 on the bottom
Fans	Four heavy-duty 8-cm fans

## Power Supply Indicator

LEDs on the power supplies indicate the status of the module

Power Supply Indicator	
LED Color and State	Power Supply Condition
Solid Green	Indicates that the power supply is on
Blinking Green	Indicates that the power supply is plugged in and turned off by the system
Blinking Amber	Indicates that the power supply has a warning condition and continues to operate.
Solid Amber	Indicates that the power supply is plugged in, and is in an abnormal state. The system might need service. Please contact Supermicro technical support.
Off	No AC power to modules

## 1.3 System Architecture

This figure below shows the locations of the main system components and a system block diagram.

### Main Components

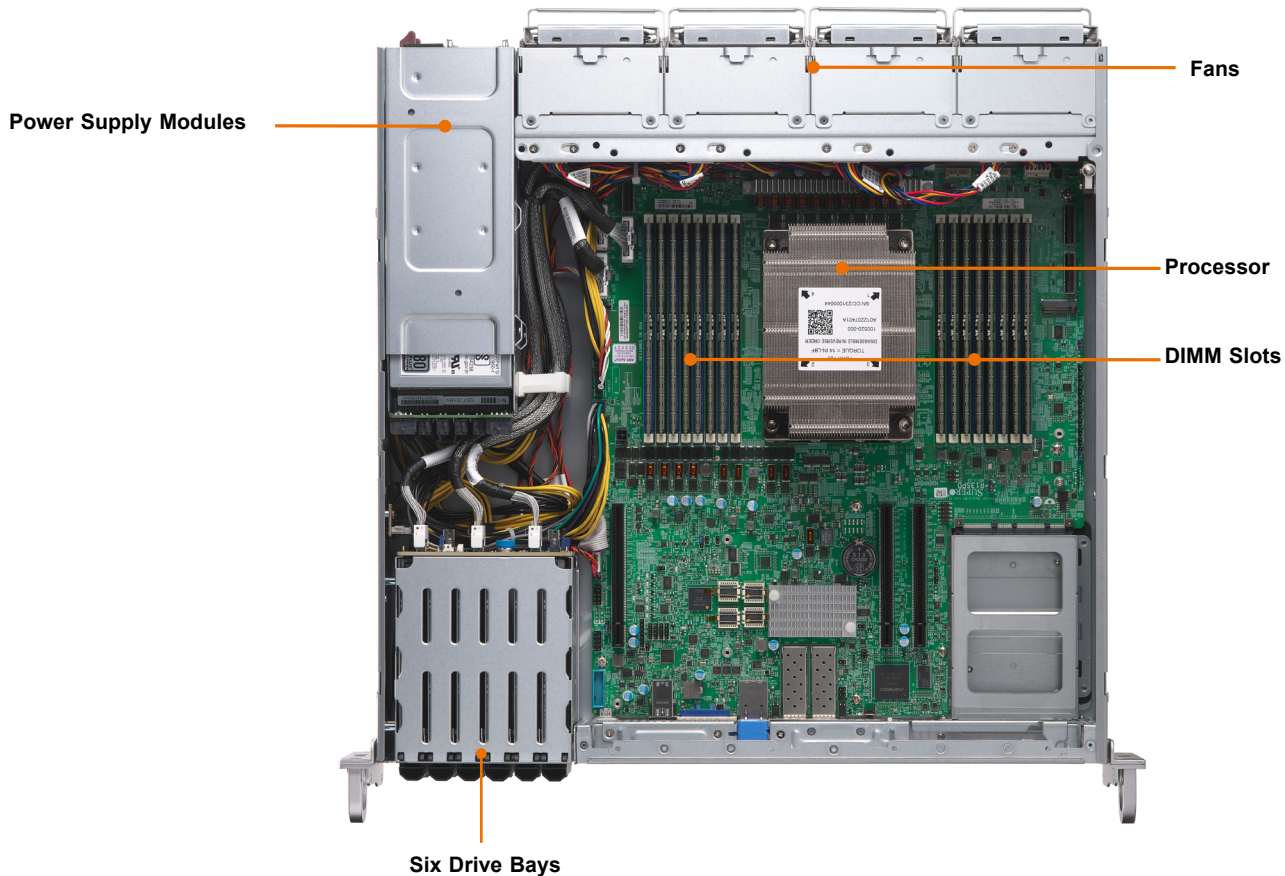

**Figure 1-4. Main Component Locations**

System Features: Top	
Feature	Description
Power Supply	PWS-1K62A-1R, two 1600 W redundant power supply modules
DIMM slots	16 DIMM slots, supports up to 8 TB of DDR5-5600 ECC RDIMM/3DS RDIMM with speeds of up to 5200 MT/s in 16 memory slots (1R2DPC)
Processor	AmpereOne processor
System Fans	Four heavy-duty 8-cm fans
PCIe	Two PCIe 5.0 x8 slots: one FHFL, one FHHL Two PCIe 5.0 x16 slots: one FHFL, one FHHL One PCIe 5.0 x16 LP slot One PCIe 5.0 x16 AIOM slot (OCP 3.0 compatible)

## System Block Diagram

The block diagram below shows the connections and relationships between the subsystems and major components of the overall system.

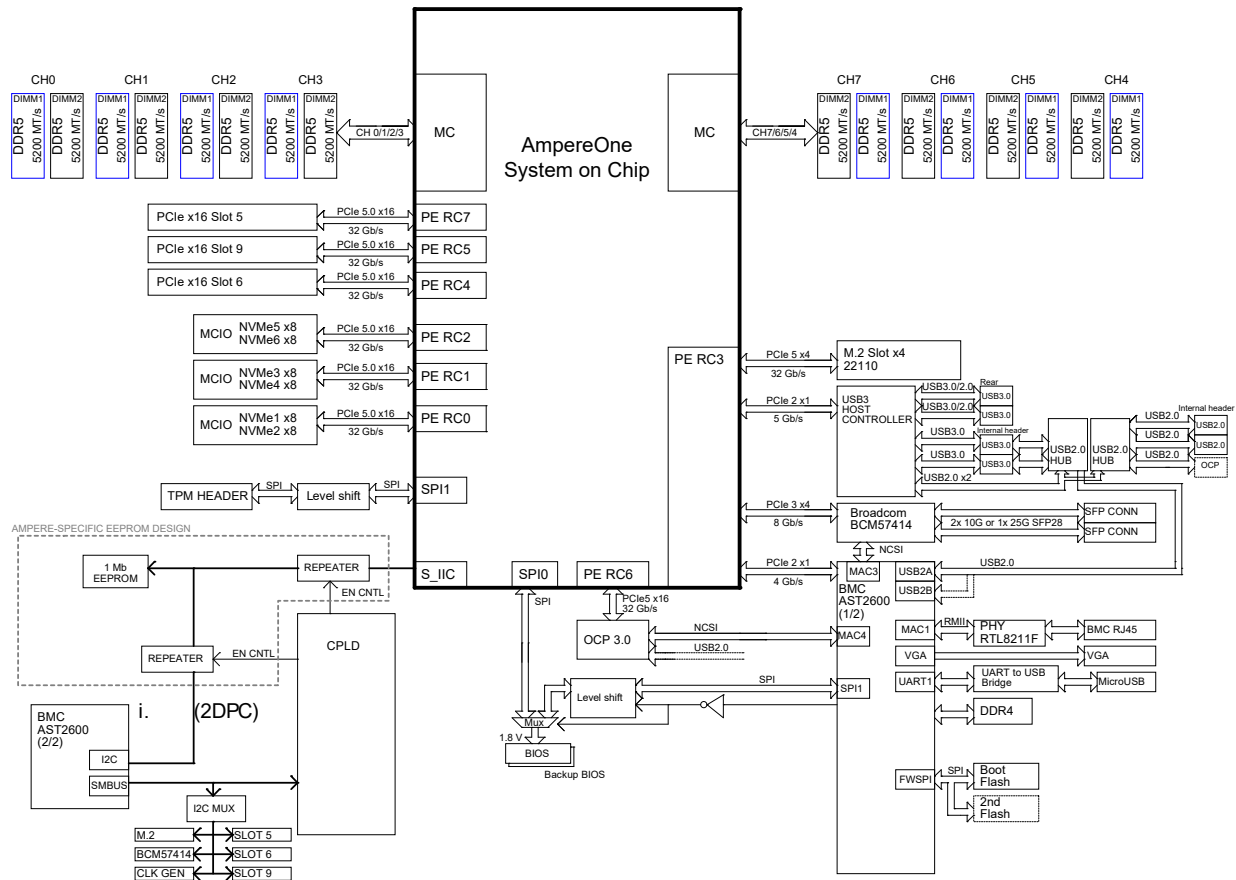

Figure 1-5. System Block Diagram

**Note:** This is a general block diagram and may not exactly represent the features on your motherboard. See the previous pages for the actual specifications of your motherboard.



## Quick Reference Table

Jumper	Description	Default Setting (*)
JONEX1	AmpereOne AC03/AmpereOne AC04 Voltage	Closed (AmpereOne AC04 CPU)
JP2	UID/Reset Button Switch	Pins 2–3 (UID)
LED	Description	Status
LE1	Unit Identifier LED	Solid Blue: Unit Identified
LE6	System Status LED	Red: Standby Green: System Power
LED_L1	SFP28 LAN Status for LAN2	Top LED Yellow: 10 G Link Top LED Green: 25 G Link Bottom LED Green: Port Activity
LED_L2	SFP28 LAN Status for LAN1	Top LED Yellow: 10 G Link Top LED Green: 25 G Link Bottom LED Green: Port Activity
LEDM2	BMC Heartbeat LED	Blinking Green: BMC Normal
Connector	Description	
BT1	Onboard CMOS Battery	
BMC_LAN	Dedicated BMC LAN Port	
COM1	COM Port through Micro-USB	
CPU AIOM	PCIe 5.0 x16 AIOM Slot for an OCP 3.0 Mezzanine Card	
FAN1 – FAN6	Processor/System Fan Headers (FAN1: Processor Fan)	
JF1	Front Control Panel Header	
JIPMB1	4-pin External I <sup>2</sup> C Header for an IPMI Card	
JL1	Chassis Intrusion Header	
JM1	M.2 M-Key PCIe 5.0 Connector (2280/22110)	
CPU SLOT5, SLOT6, SLOT9	PCIe 5.0 x16 Slots	
JPI2C1	Power Supply SMBus I <sup>2</sup> C Header	
JPWR1	Proprietary PSU 14-Pin Power Connector	
JWPR3	Proprietary PSU 8-Pin Power Connector	
JWPR11	Proprietary PSU 8-Pin Power Connector	
JPWR7	5 V/12 V Power Connector for Special Riser Card	
JTPM1	Trusted Platform Module (TPM)	
JUIDB1	Unit Identifier Button	
LAN1, LAN2	SFP28 10 G/25 G LAN Ports	
NVMe1 x8 – NVMe6 x8	PCIe 5.0 x8 MCIO Connectors for NVMe	
USB1/2 (3.0)	USB 3.0 Type-A Ports on the Rear I/O Ports	
USB3/4 (3.0)	Front-Accessible USB 3.0 Header	

**Note:** Table continues on the next page.

<b>Connector</b>	<b>Description</b>
USB5/6 (2.0)	Front-Accessible USB 2.0 Header
JVGA1	VGA Port

# Chapter 2

## Server Installation

### 2.1 Overview

This chapter provides advice and instructions for mounting your system in a server rack. If your system is not already fully integrated with processors, system memory, etc., refer to [Chapter 3](#) for details on installing those specific components.

**Caution:** Electrostatic Discharge (ESD) can damage electronic components. To prevent such damage to PCBs (printed circuit boards), it is important to use a grounded wrist strap, handle all PCBs by their edges and keep them in anti-static bags when not in use.

### 2.2 Unpacking the System

Inspect the box in which the system was shipped, and note if it was damaged in any way. If any equipment appears damaged, file a damage claim with the carrier who delivered it.

Decide on a suitable location for the rack unit that will hold the server. It should be situated in a clean, dust-free area that is well ventilated. Avoid areas where heat, electrical noise, and electromagnetic fields are generated. It will also require a grounded AC power outlet nearby. Be sure to read the precautions and considerations noted or in [Appendix A](#).

### 2.3 Preparing for Setup

The box in which the system was shipped should include the rackmount hardware needed to install it into the rack. Please read this section in its entirety before you begin the installation.

#### Choosing a Setup Location

- The system should be situated in a clean, dust-free area that is well ventilated. Avoid areas where heat, electrical noise, and electromagnetic fields are generated.
- Leave enough clearance in front of the rack so that you can open the front door completely (~25 inches) and approximately 30 inches of clearance in the back of the rack to allow sufficient space for airflow and access when servicing.
- This product should be installed only in a Restricted Access Location (dedicated equipment rooms, service closets, etc.).
- This product is not suitable for use with visual display workplace devices according to §2 of the German Ordinance for Work with Visual Display Units.

## Rack Precautions

- Ensure that the leveling jacks on the bottom of the rack are extended to the floor so that the full weight of the rack rests on them.
- In single rack installations, stabilizers should be attached to the rack. In multiple rack installations, the racks should be coupled together.
- Always make sure the rack is stable before extending a server or other component from the rack.
- Extend only one server or component at a time - extending two or more simultaneously may cause the rack to become unstable.

## Server Precautions

- Review the electrical and general safety precautions in [Appendix A](#).
- Determine the placement of each component in the rack before you install the rails.
- Install the heaviest server components at the bottom of the rack first and then work your way up.
- Use a regulating uninterruptible power supply (UPS) to protect the server from power surges and voltage spikes and to keep your system operating in case of a power failure.
- Allow any drives and power supply modules to cool before touching them.
- When not servicing, always keep the front door of the rack and all covers/panels on the servers closed to maintain proper cooling.

## Rack Mounting Considerations

### *Ambient Operating Temperature*

If installed in a closed or multi-unit rack assembly, the ambient operating temperature of the rack environment may be greater than the room's ambient temperature. Therefore, consideration should be given to installing the equipment in an environment compatible with the manufacturer's maximum rated ambient temperature (TMRA).

### *Airflow*

Equipment should be mounted into a rack so that the amount of airflow required for safe operation is not compromised.

### ***Mechanical Loading***

Equipment should be mounted into a rack so that a hazardous condition does not arise due to uneven mechanical loading.

### ***Circuit Overloading***

Consideration should be given to the connection of the equipment to the power supply circuitry and the effect that any possible overloading of circuits might have on overcurrent protection and power supply wiring. Appropriate consideration of equipment nameplate ratings should be used when addressing this concern.

### ***Reliable Ground***

A reliable ground must be maintained at all times. To ensure this, the rack itself should be grounded. Particular attention should be given to power supply connections other than the direct connections to the branch circuit (i.e. the use of power strips, etc.).

**Important:** To prevent bodily injury when mounting or servicing this unit in a rack, you must take special precautions to ensure that the system remains stable. The following guidelines are provided to ensure your safety:

- This unit should be mounted at the bottom of the rack if it is the only unit in the rack.
- When mounting this unit in a partially filled rack, load the rack from the bottom to the top with the heaviest component at the bottom of the rack.
- If the rack is provided with stabilizing devices, install the stabilizers before mounting or servicing the unit in the rack.
- Slide rail mounted equipment is not to be used as a shelf or a workspace.

**Important:** Slide rail mounted equipment is not to be used as a shelf or a workspace.

**Important:** Do not pick up the server with the front handles. They are designed to pull the system from a rack only.

## 2.4 Installing the Rails

This section provides information on installing the chassis into a rack unit with the rails provided. There are a variety of rack units on the market, which may mean that the assembly procedure will differ slightly from the instructions provided. You should also refer to the installation instructions that came with the rack unit you are using.

**Note:** This rail will fit a rack between 26.8" and 36.4" deep.

### Identifying the Rails

The chassis package includes two rail assemblies. Each assembly consists of three sections: An inner rail that secures directly to the chassis, an outer rail that secures to the rack, and a middle rail which extends from the outer rail. These assemblies are specifically designed for the left and right side of the chassis and labeled.

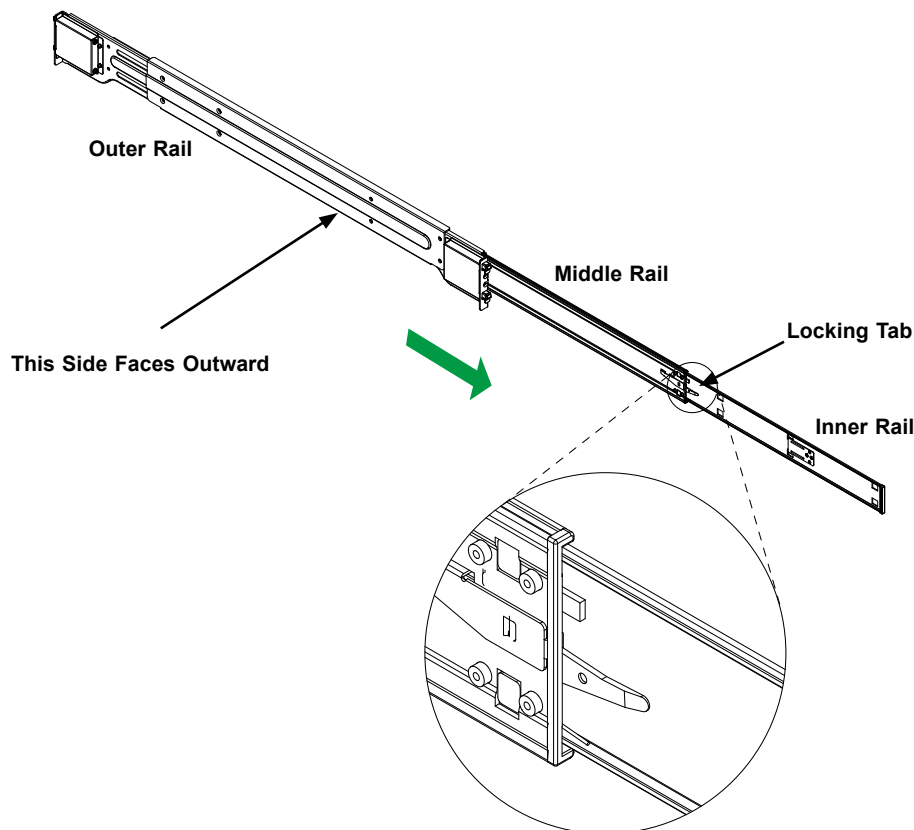

**Figure 2-1. Identifying the Outer Rail, Middle Rail, and Inner Rail (Left Rail Assembly Shown)**

**Note:** Both front chassis rails and the rack rails have a locking tab, which serves two functions. First, it locks the chassis into place when installed and pushed fully into the rack (its normal operating position). In addition, these tabs lock the chassis in place when fully extended from the rack. This prevents the chassis from coming completely out of the rack when pulled out for servicing.

## Releasing the Inner Rail

Each inner rail has a locking latch. This latch prevents the chassis from coming completely out of the rack when the chassis is pulled out for servicing.

To mount the rail onto the chassis, first release the inner rail from the outer rails.

1. Pull the inner rail out of the outer rail until it is fully extended as illustrated below.
2. Press the locking tab down to release the inner rail.
3. Pull the inner rail all the way out.

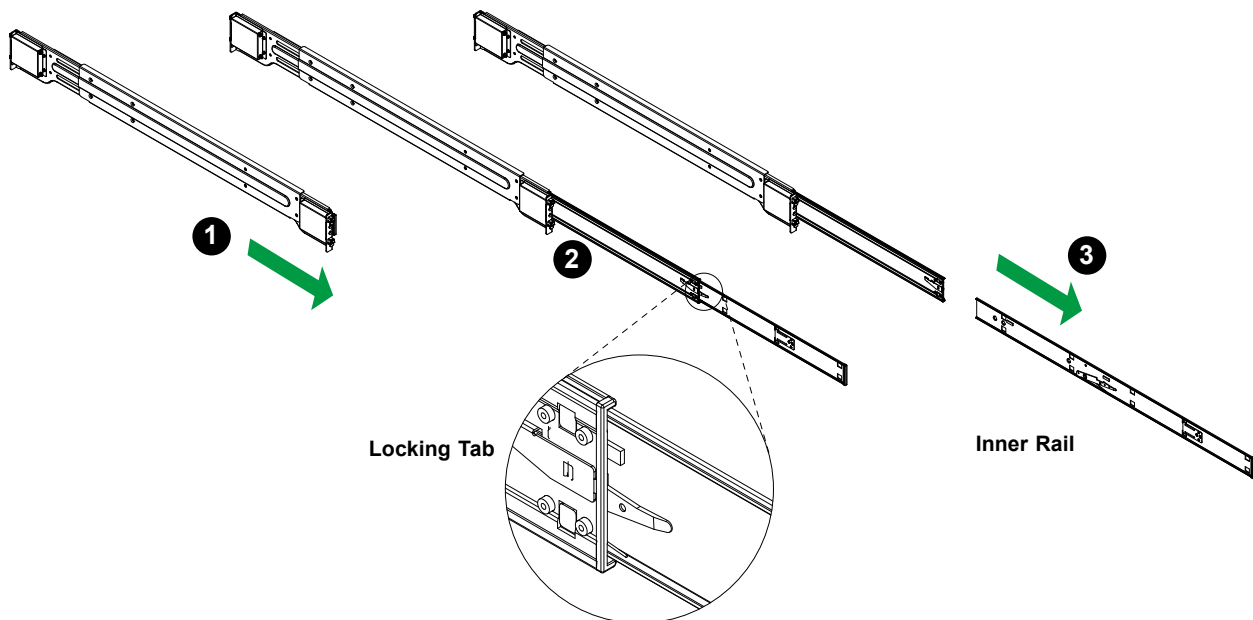

Figure 2-2. Extending and Releasing the Inner Rail

**Important:** Slide rail mounted equipment is not to be used as a shelf or a work space.

## Installing the Inner Rails

Begin the rack mounting procedure by installing the inner rails to the chassis.

1. Identify the left and right inner rails. They are labeled.
2. Place the inner rail firmly against the side of the chassis, aligning the hooks in the chassis with the inner rail's.
3. Secure the inner rail to the chassis with screws provided by the rail manufacturer.

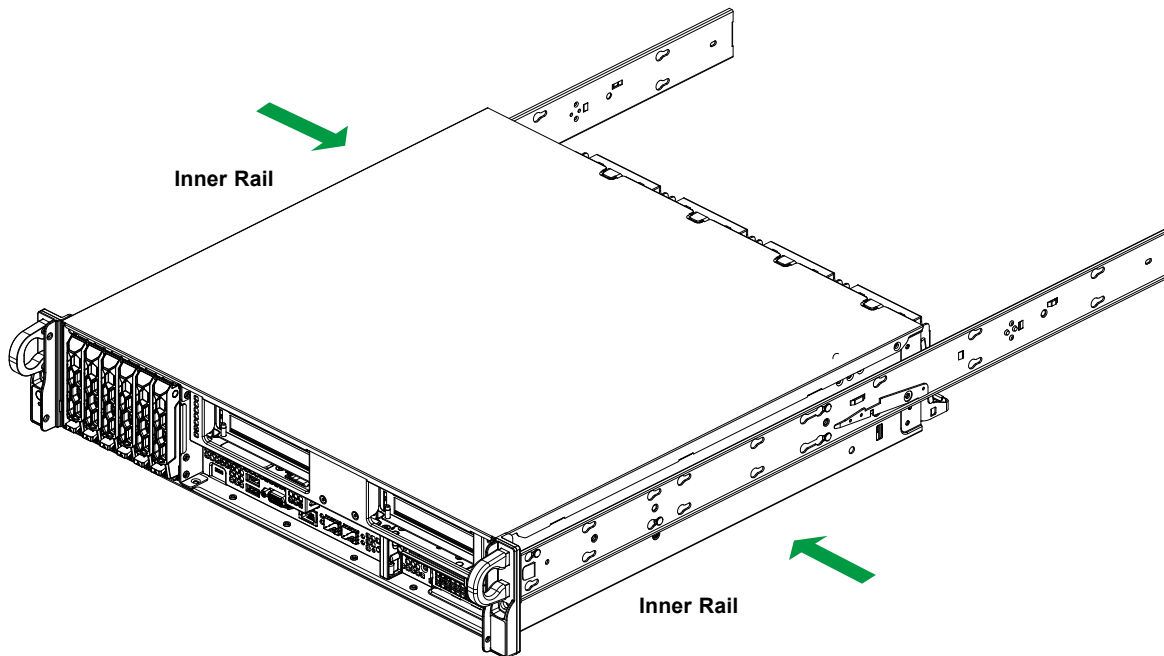

Figure 2-3. Installing the Rails

**Important:** Do not pick up the chassis with the front handles. They are designed to pull the system from a rack only.

## Installing the Outer Rails onto the Rack

1. Press upward on the locking tab at the rear end of the middle rail.
2. Push the middle rail back into the outer rail.
3. Hang the hooks on the front of the outer rail onto the square holes on the front of the rack. If desired, use screws to secure the outer rails to the rack.
4. Pull out the rear of the outer rail, adjusting the length until it just fits within the posts of the rack.
5. Hang the hooks of the rear section of the outer rail onto the square holes on the rear of the rack. Take care that the proper holes are used so the rails are level. If desired, use screws to secure the rear of the outer rail to the rear of the rack.

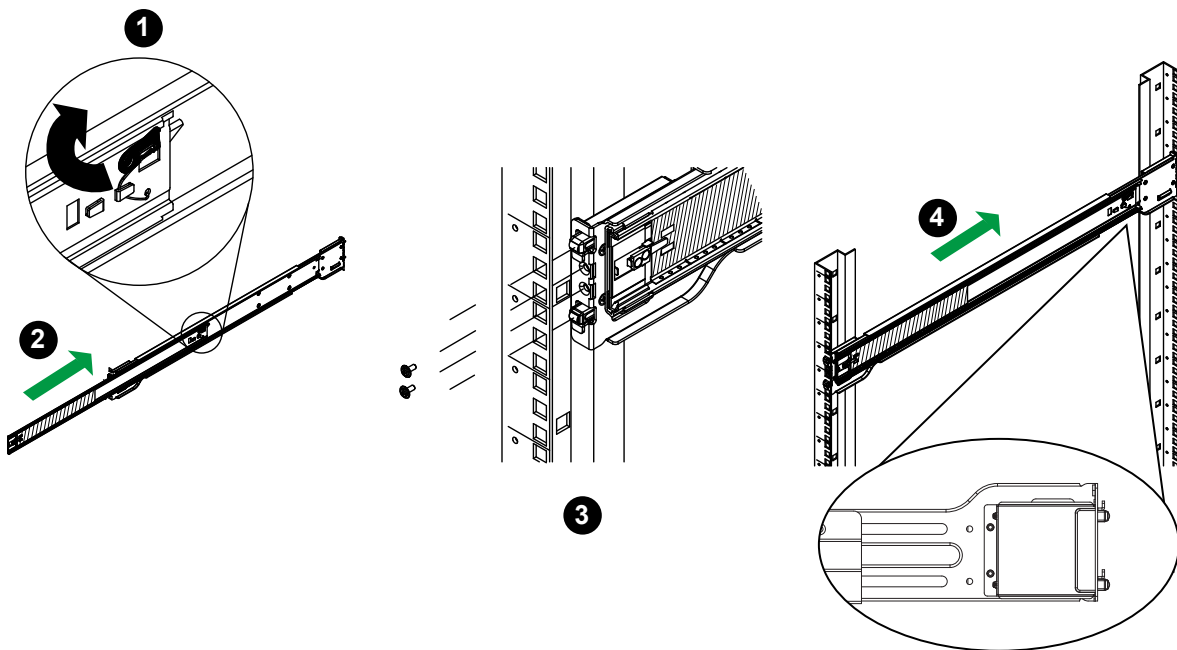
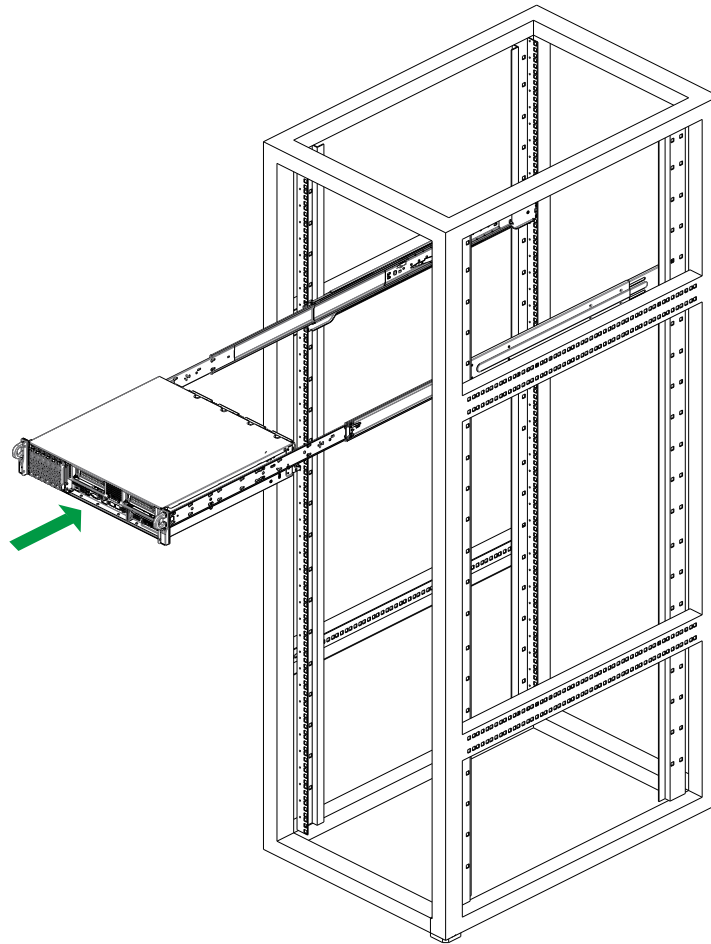

Figure 2-4. Extending and Mounting the Outer Rails

## 2.5 Installing the Chassis into a Rack

Once rails are attached to the chassis and the rack, you can install the server.

1. Pull the middle rail out of the front of the outer rail and make sure that the ball bearing shuttle is locked at the front of the middle rail.
2. Align the rear of the chassis rails with the middle rails and then push evenly on both sides of the chassis until it clicks into the fully extended position.
3. Depress the locking tabs on both sides of the chassis and push the it fully into the rack. The locking tabs should "click".
4. Optional screws may be used to hold the front of the chassis to the rack.



**Figure 2-5. Installing the Server into the Rack**

**Note:** Keep the ball bearing shuttle locked at the front of the middle rail during installation.

**Note:** Figure is for illustrative purposes only. Always install servers to the bottom of a rack first.

## Removing the Chassis from the Rack

**Caution!** It is dangerous for a single person to off-load the heavy chassis from the rack without assistance. Be sure to have sufficient assistance supporting the chassis when removing it from the rack. Use a lift.

1. Pull the chassis forward out the front of the rack until it stops.
2. Press the release latches on each of the inner rails downward simultaneously and continue to pull the chassis forward and out of the rack.

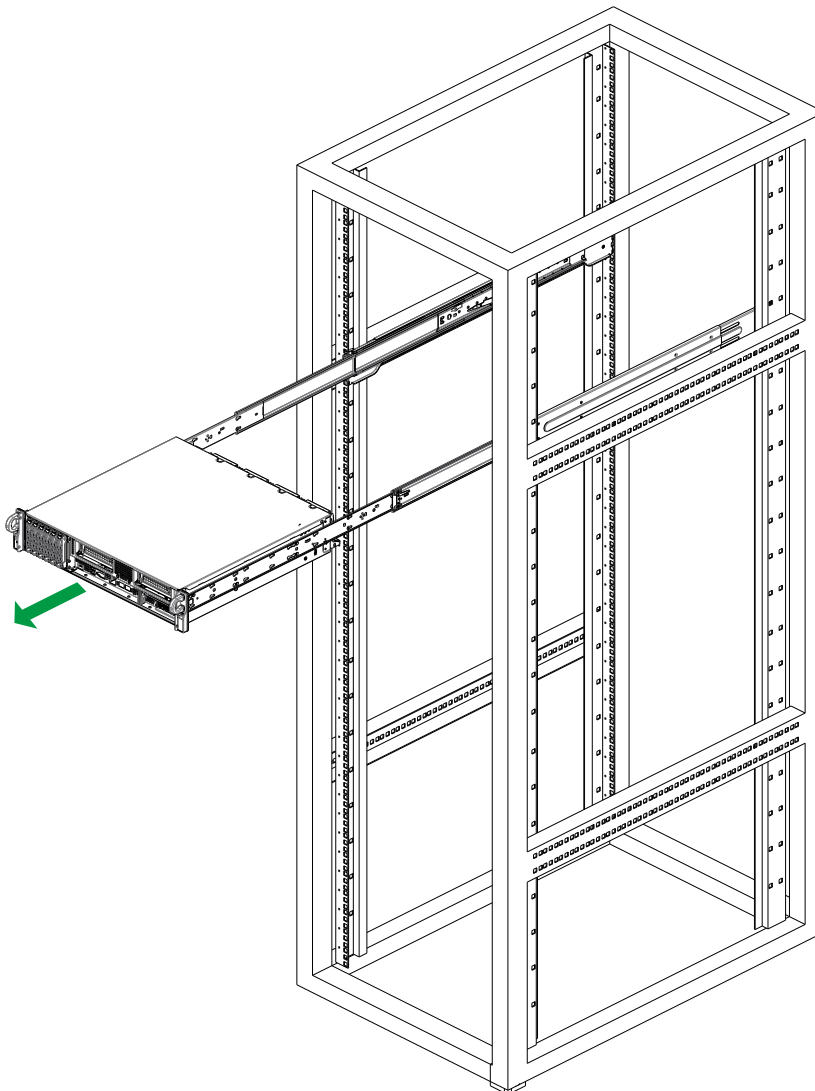

Figure 2-6. Removing the Chassis From the Rack

## Chapter 3

# Maintenance and Component Installation

This chapter provides instructions on installing and replacing main system components. To prevent compatibility issues, only use components that match the specifications and/or part numbers given.

Installation or replacement of most components requires that power first be removed from the system. Please follow the procedures given in each section.

### 3.1 Removing Power

Use the following procedure to ensure that power has been removed from the system. This step is necessary when removing or installing non-hot-swap components or when replacing a non-redundant power supply.

1. Use the operating system to power down the system.
2. After the system has completely shut-down, disconnect the AC power cord(s) from the power strip or outlet. (If your system has more than one power supply, remove the AC power cords from all power supply modules.)
3. Disconnect the power cord(s) from the power supply module(s).

## 3.2 Accessing the System

The CSE-LB23MTS-R000NDP chassis features a removable top cover, which allows easy access to the inside of the chassis.

### *Removing the Top Cover*

1. Remove the screw on each side of the chassis.
2. Slide the cover and lift it off.

**Caution:** Except for short periods of time, do not operate the server without the cover in place. The chassis cover must be in place to allow for proper airflow and to prevent overheating.

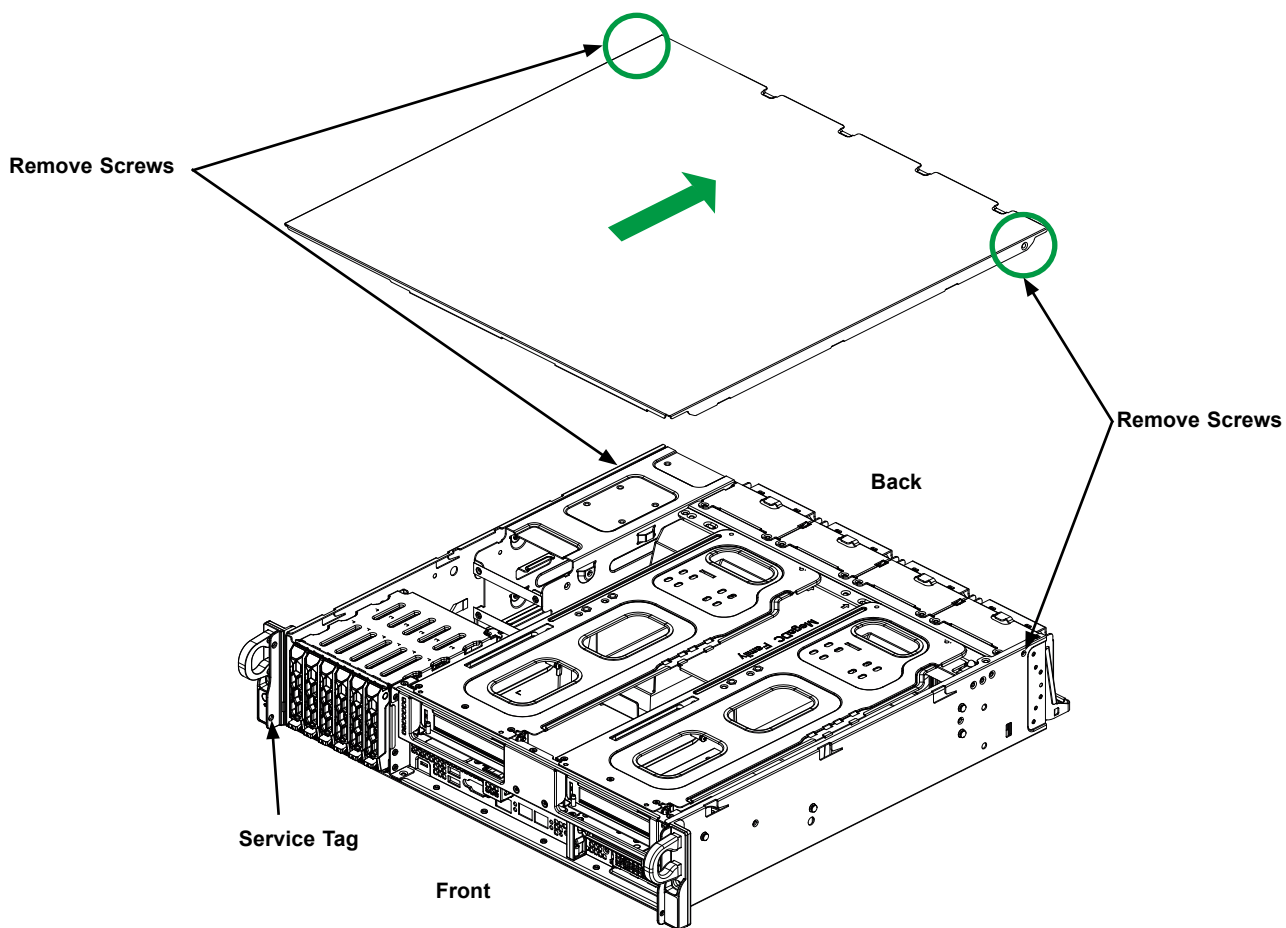

Figure 3-1. Removing the Chassis Cover

## 3.3 Static-Sensitive Devices

Electrostatic Discharge (ESD) can damage electronic components. To avoid damaging your motherboard, it is important to handle it very carefully. The following measures are generally sufficient to protect the system PCBs from ESD.

### Precautions

- Use a grounded wrist strap designed to prevent static discharge.
- Touch a grounded metal object before removing any PCB (printed circuit board) from its antistatic bag.
- Handle PCBs by their edges only; do not touch its components, peripheral chips, memory modules, or gold contacts.
- When handling chips or modules, avoid touching their pins.
- When installing the processor and heatsink, ensure a torque driver set to the correct force is used for each screw.
- Put the PCBs back into their antistatic bags when not in use.
- For grounding purposes, make sure that your computer chassis provides excellent conductivity between the power supply, the case, the mounting fasteners and the motherboard.
- Use only the correct type of onboard CMOS battery. Do not install the onboard battery upside down to avoid a possible explosion

### Unpacking

The motherboard is shipped in antistatic packaging to avoid static damage. When unpacking the motherboard, make sure that the person handling it is static protected.

## 3.4 Processor and Heatsink Installation

### Notes:

- Use ESD protection.
- Shut down the system and then unplug the AC power cord from all power supplies.
- Check that the plastic protective cover is on the CPU socket and none of the socket pins are bent. If they are, contact your retailer.
- When handling the processor, avoid touching or placing direct pressure on the LGA lands (gold contacts). Improper installation or socket misalignment can cause serious damage to the processor or socket, which may require manufacturer repairs.
- When installing the processor and heatsink, ensure a torque driver set to the correct force is used for each screw.
- Refer to the Supermicro website for updates on processor support.
- All graphics in this manual are for illustrations only. Your components may look different.

### The AmpereOne Processor

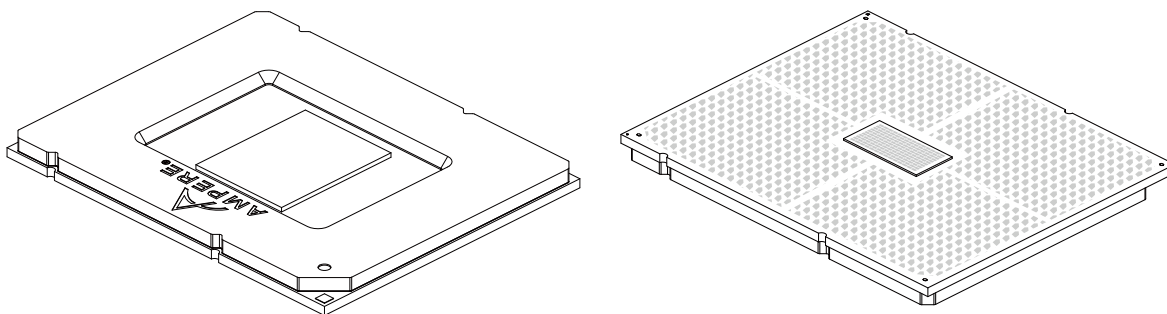

## Overview of the Processor Socket

The processor socket is protected by a plastic protective cover and pre-installed with a processor carrier.

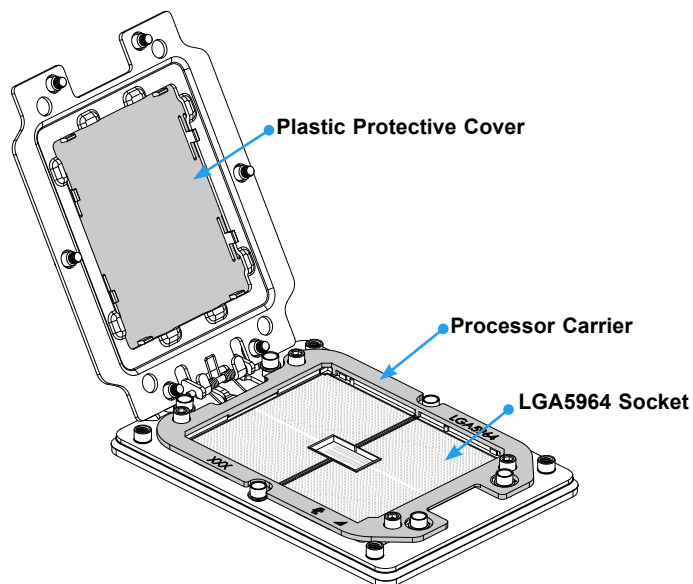

## Overview of the Heatsink

The heatsink is attached to the processor after the processor is secured in the LGA5964 socket. If this is a new heatsink, thermal grease is pre-applied.

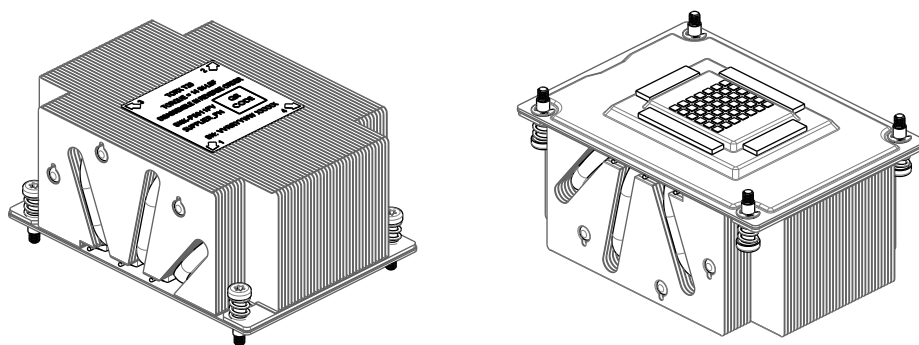

## Installing the Processor

1. Use a screwdriver with a T20 bit to unscrew the socket force frame. Unscrew counterclockwise in the sequence 6-5-4-3-2-1. The screws are numbered on the socket force frame next to each screw hole.

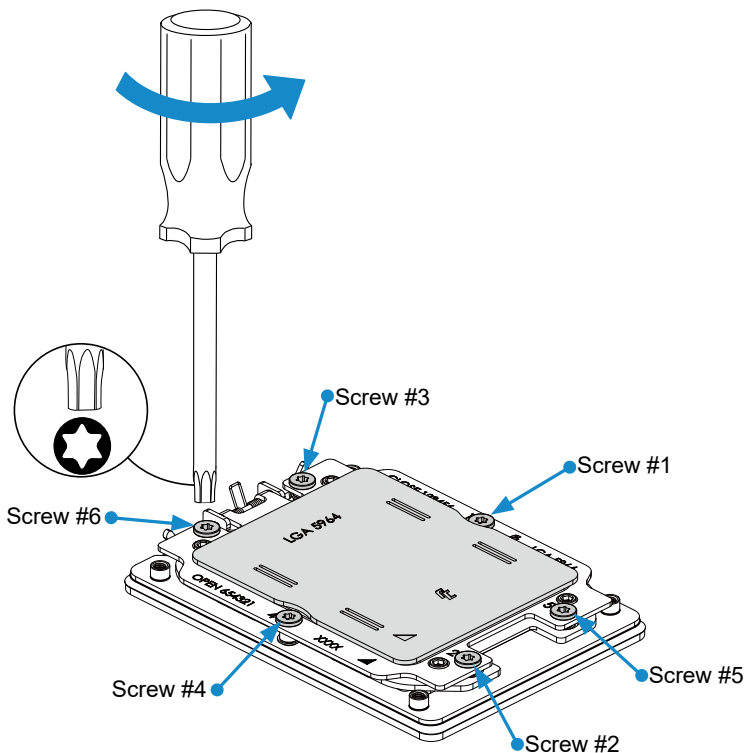

2. The socket force frame will raise up after the last screw securing it (#1) is removed. Gently allow it to lift up to its stopping position.

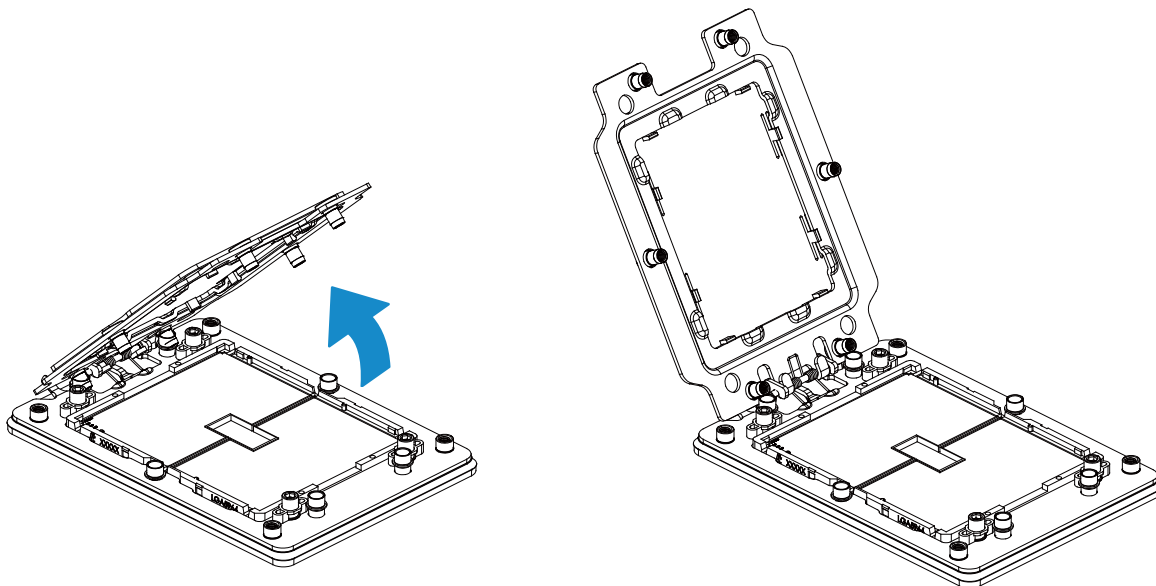

3. Turn the processor over so the gold contacts are facing up, and also turn the processor carrier over. Align pin 1 on the processor with pin 1 location on the carrier.

**Note:** The carrier (Part Number: SKT-1537H-0000-FXC) will either be shipped with the system or accompany the CPU. If the carrier is not included, please contact Supermicro.

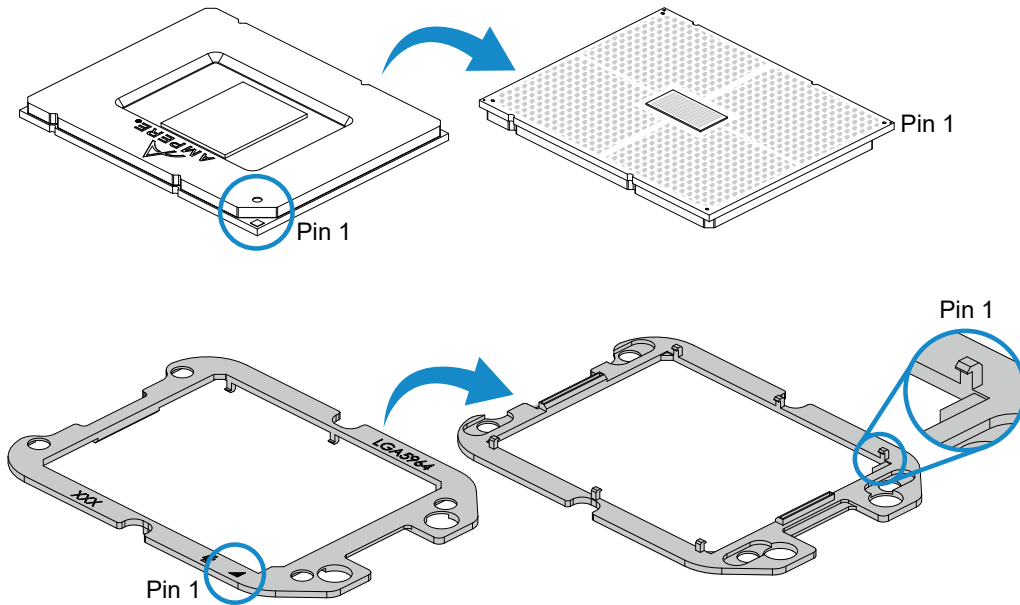

4. Place one side of the processor into the carrier, then place the other side of the processor into the carrier as shown below.

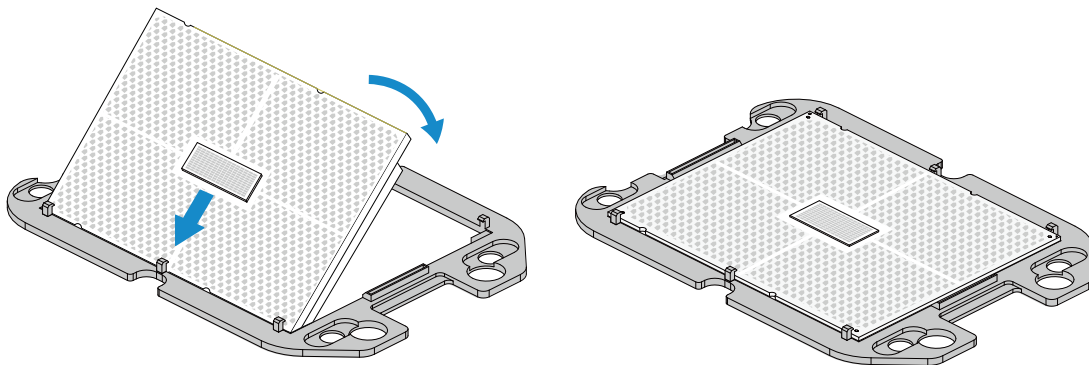

5. Turn over the processor carrier assembly with the top side facing up.

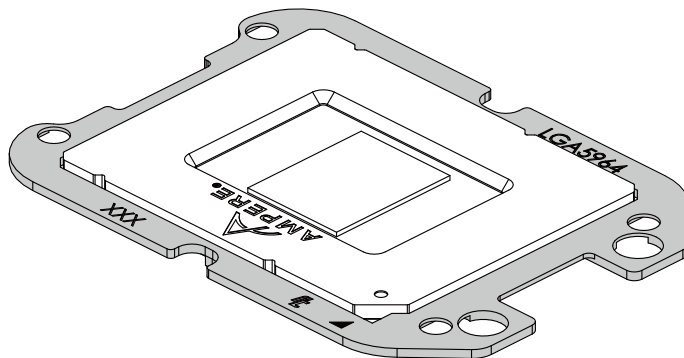

6. Align the processor pad cutout on the corner to the bottom-right corner of the socket. Also align the carrier's mounting holes with the respective screw holes on the socket.

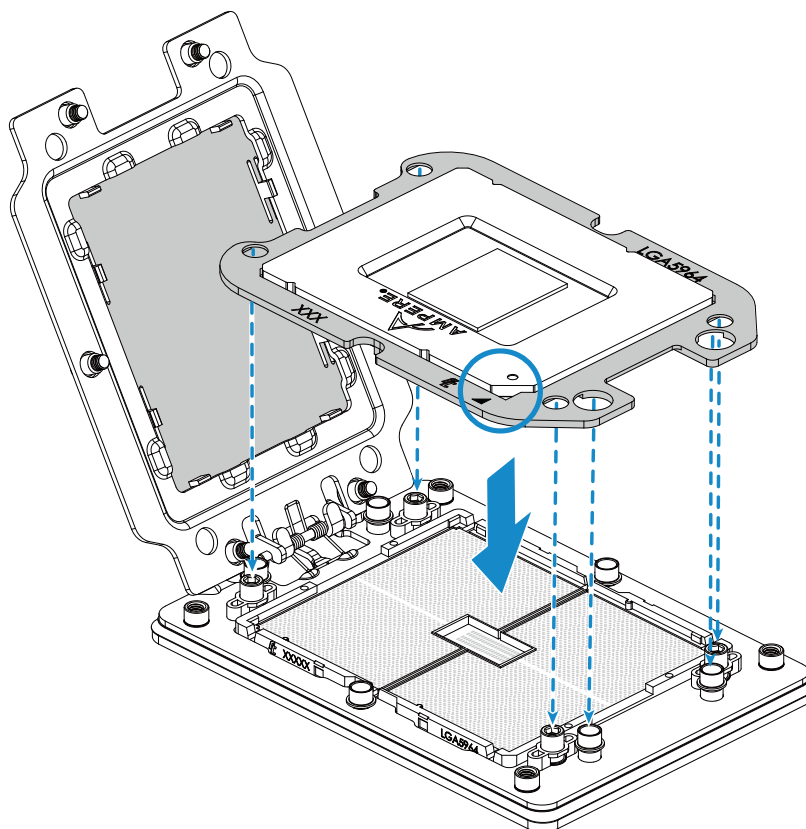

7. Remove the plastic protective cover from the socket force frame.

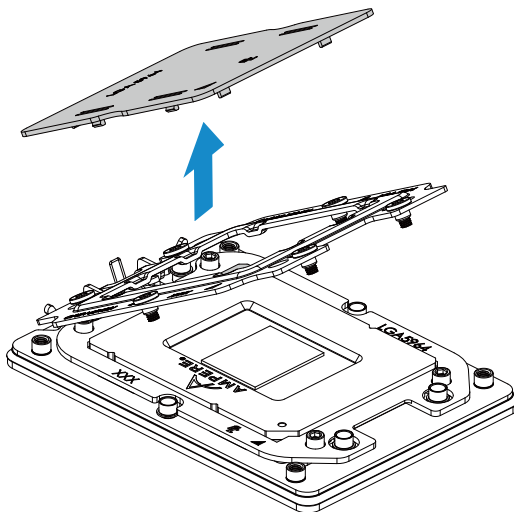

8. Using a torque driver set to a force of  $12.0 \pm 1$  in-lbf (1.242-1.469 N-m) with a T20 bit to screw in the socket force frame. Tighten the screws clockwise in the sequence 1-2-3-4-5-6. The socket force frame is spring-loaded and must be held in place.

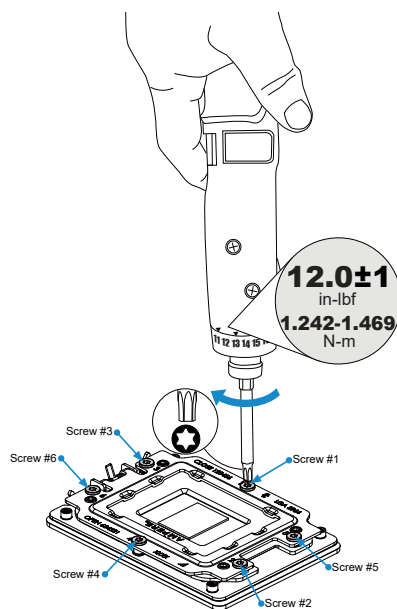

9. When finished, the socket force frame will secure the processor.

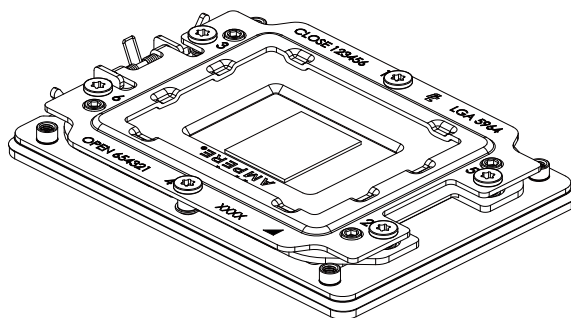

## Installing the Heatsink

1. After the processor is secure, you must install the heatsink to the socket frame. Ensure a proper amount of thermal grease is applied to the heatsink. Lower the heatsink down until the four screws on the heatsink align with the four screw holes on the socket frame.

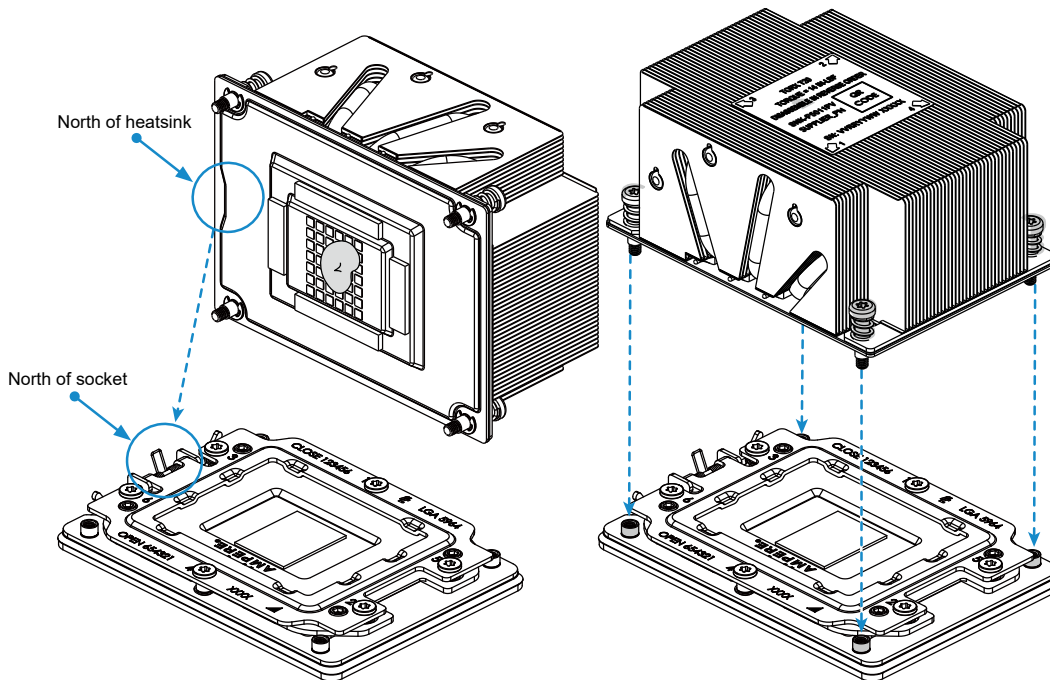

2. Using a T20 bit torque driver set to a force of 12-14 in-lbf (1.356-1.582 N-m), tighten the heatsink screws in the sequence 1-2-3-4.

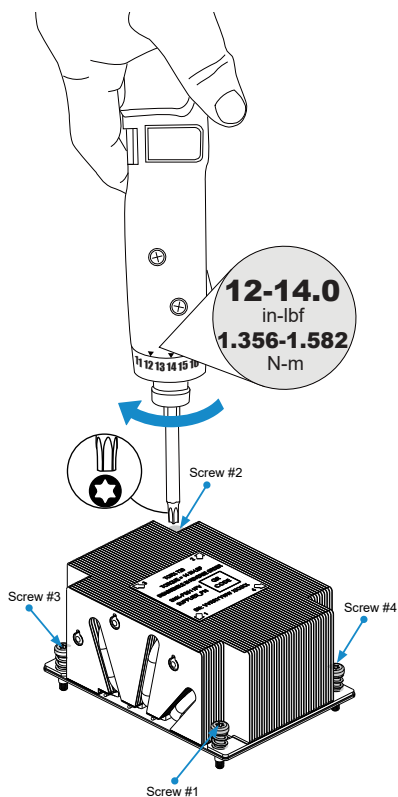



## 3.5 Motherboard Installation

All motherboards have standard mounting holes to fit different types of chassis. Make sure that the locations of all the mounting holes for both the motherboard and the chassis match. Although a chassis may have both plastic and metal mounting fasteners, metal ones are highly recommended because they ground the motherboard to the chassis. Make sure that the metal standoffs click in or are screwed in tightly.

### Tools Needed



Torque driver (1)

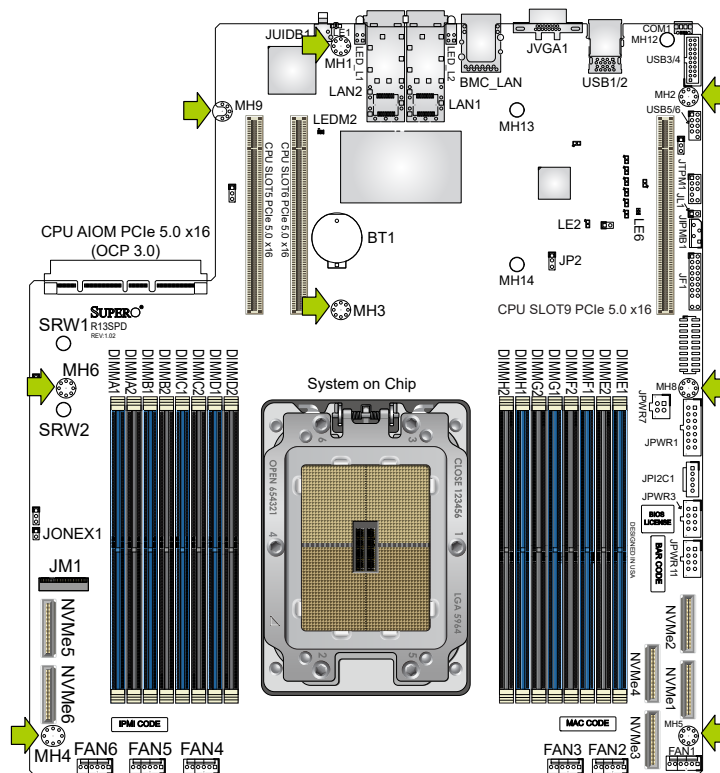

Phillips Screws (8)

Standoffs (8)  
Only if Needed

### Location of Mounting Holes

**Note 1:** Do not use a force greater than 8 in-lbf (0.904 N-m) on each mounting screw during motherboard installation. Exceeding this force may over-torque the screw, causing damage to the motherboard and screw.

**Note 2:** Some components are very close to the mounting holes. Take precautionary measures to avoid damaging these components when installing the motherboard to the chassis.

## Installing the Motherboard

1. Install the I/O shield into the back of the chassis, if applicable.

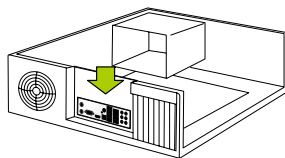

2. Locate the mounting holes on the motherboard. See the previous page for the location.

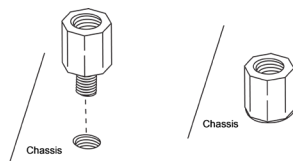

3. Locate the matching mounting holes on the chassis. Align the mounting holes on the motherboard against the mounting holes on the chassis.

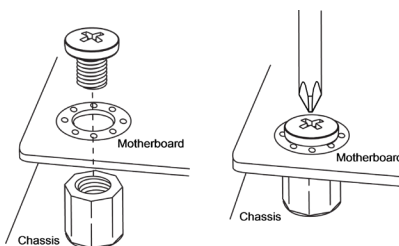

4. Install standoffs in the chassis as needed.
5. Install the motherboard into the chassis carefully to avoid damaging other motherboard components.
6. Using the Phillips screwdriver, insert a pan head #6 screw into a mounting hole on the motherboard and its matching mounting hole on the chassis.
7. Repeat Step 6 to insert #6 screws into all mounting holes.
8. Make sure that the motherboard is securely placed in the chassis.

**Note:** Images displayed in this user manual are for illustration only. Your chassis or components might look different from those shown.

## 3.6 Memory Support and Installation

**Note:** Check the Supermicro website for recommended memory modules.

**Important:** Exercise extreme care when installing or removing memory modules to prevent any possible damage.

### Memory Support

The R13SPD motherboard supports up to 8 TB of DDR5 ECC RDIMM/3DS RDIMM memory with speeds of up to up to 5200 MT/s in 16 memory slots (2DPC). Refer to the table below for the recommended DIMM population order and additional memory information.

### DIMM Module Population Configuration

For optimal memory performance, follow the table below when populating memory.

16 DIMM Slots		
Number of DIMMs	DIMMs per Channel (DPC)	Memory Population Sequence
1	1DPC	DIMMA1
2	1DPC	DIMMA1 / DIMME1
4	1DPC	DIMMA1 / DIMMB1 / DIMME1 / DIMMF1
6	1DPC	DIMMA1 / DIMMB1 / DIMMC1 / DIMME1 / DIMMF1 / DIMMG1
8	1DPC	DIMMA1 / DIMMB1 / DIMMC1 / DIMMD1 / DIMME1 / DIMMF1 / DIMMG1 / DIMMH1
16	2DPC	DIMMA1 / DIMMB1 / DIMMC1 / DIMMD1 / DIMMA2 / DIMMB2 / DIMMC2 / DIMMD2 / DIMME1 / DIMMF1 / DIMMG1 / DIMMH1 / DIMME2 / DIMMF2 / DIMMG2 / DIMMH2

## General Guidelines for Optimizing Memory Performance

- DIMM slots must be populated in the following order: DIMMA1, DIMMB1, DIMMC1, DIMMD1, DIMME1, DIMMF1, DIMMG1, DIMMH1, and then DIMMA2, DIMMB2, DIMMC2, DIMMD2, DIMME2, DIMMF2, DIMMG2, DIMMH2.
- It's recommended to use DDR5 memory of the same type, size, and speed.
- Mixed DIMM speeds can be installed. However, all DIMMs will run at the speed of the slowest DIMM.
- The motherboard will support odd-numbered modules. However, to achieve the best memory performance, a balanced memory population is recommended.

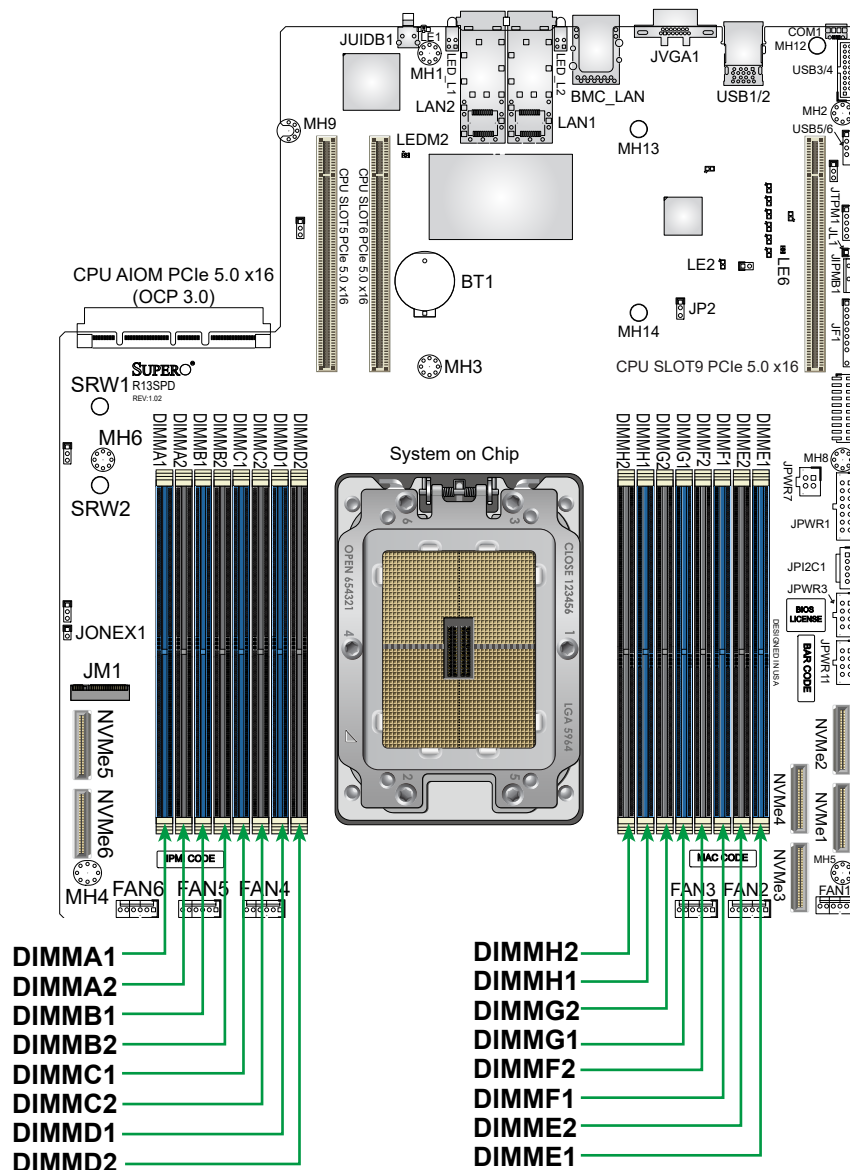

## DIMM Installation

1. Insert DIMM modules in the following order: DIMMA1, DIMMB1, DIMMC1, DIMMD1, DIMME1, DIMMF1, DIMMG1, DIMMH1, and then DIMMA2, DIMMB2, DIMMC2, DIMMD2, DIMME2, DIMMF2, DIMMG2, DIMMH2.
2. Push the release tabs outwards on both ends of the DIMM slot to unlock it.
3. Align the key of the DIMM module with the receptive point on the memory slot.
4. Align the notches on both ends of the module against the receptive points on the ends of the slot.
5. Push both ends of the module straight down into the slot until the module snaps into place.
6. Press the release tabs to the lock positions to secure the DIMM module into the slot.

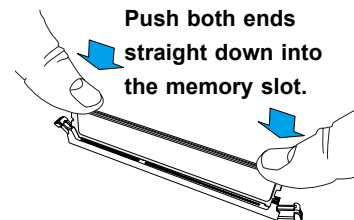
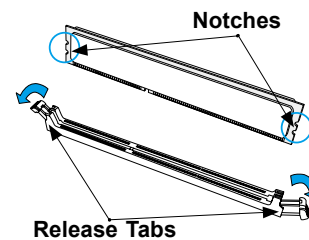
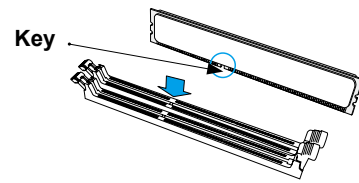
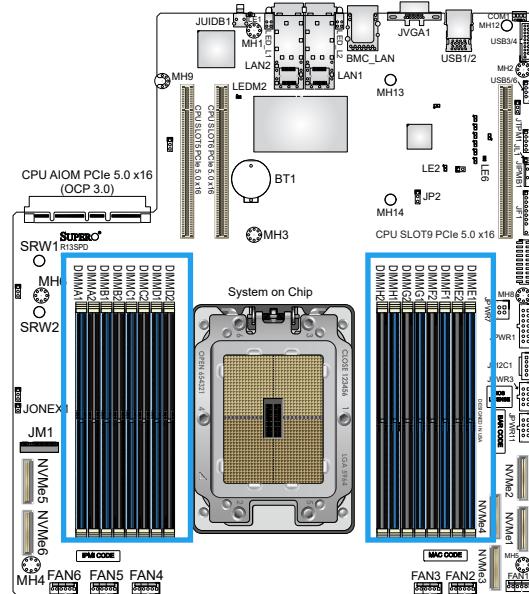

## DIMM Removal

Press both release tabs on the ends of the DIMM module to unlock it. Once the DIMM module is loosened, remove it from the memory slot.

## 3.7 Motherboard Battery

### Battery Removal

**To remove the onboard battery, follow the steps below:**

1. Power off your system and unplug your power cable.
2. Locate the onboard battery as shown below.
3. Using a tool such as a pen or a small screwdriver, push the battery lock outwards to unlock it. Once unlocked, the battery will pop out from the holder.
4. Remove the battery.

### Proper Battery Disposal

**Important:** Handle used batteries carefully. Do not damage the battery in any way; a damaged battery may release hazardous materials into the environment. Do not discard a used battery in the garbage or a public landfill. Comply with the regulations set up by your local hazardous waste management agency to dispose of your used battery properly.

### Battery Installation

**To install an onboard battery, follow the steps below:**

**Important:** When replacing a battery, be sure to only replace it with the same type.

1. Identify the battery's polarity. The positive (+) side should be facing up.
2. Insert the battery into the battery holder and push it down until you hear a click to ensure that the battery is securely locked.

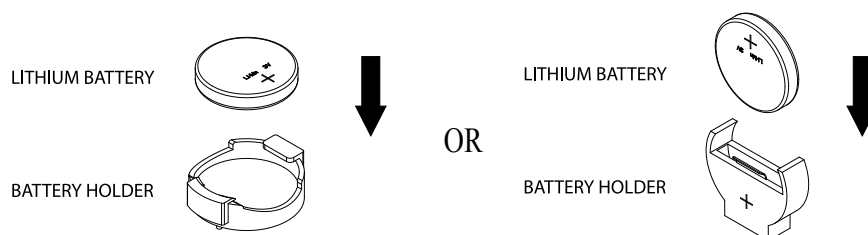

## 3.8 Storage Drives

The CSE-LB23MTS-R000NDP chassis supports up to six 2.5" storage drives in drive carriers to simplify their removal from the chassis. These carriers also help promote proper airflow.

**Note:** Enterprise level storage drives are recommended for use in Supermicro chassis and servers.



Figure 3-2. Logical Drive Numbers

### Drive Carrier Indicators

Each drive carrier has two LED indicators: an activity indicator and a status indicator. For RAID configurations using a controller, the meaning of the status indicator is described in the table below. For OS RAID or non-RAID configurations, some LED indications are not supported, such as hot spare.

Drive Carrier LED Indicators			
	Color	Blinking Pattern	Behavior for Device
Activity LED	Blue	Solid On	Idle SAS drive installed
	Blue	Blinking	I/O activity
	Off		Idle SATA or no drive
Status LED	Red	Solid On	Drive failed
	Red	Blinking at 1 Hz	Rebuilding drive
	Red	Blinking at 4 Hz	Identifying drive
	Red	Blinking with two blinks and one stop at 1 Hz	Hot spare for drive
	Red	On for five seconds, then off	Power on for drive

## Installing Drives

### *Removing Drive Carriers from the Chassis*

1. Push the release button on the drive carrier. This releases and extends the drive carrier handle.
2. Use the handle to pull the carrier out of the chassis as shown below.

**Caution:** Except for short periods of time (swapping drives), to ensure proper airflow do not operate the server with the drive carriers removed from the bays, regardless of how many drives are installed.

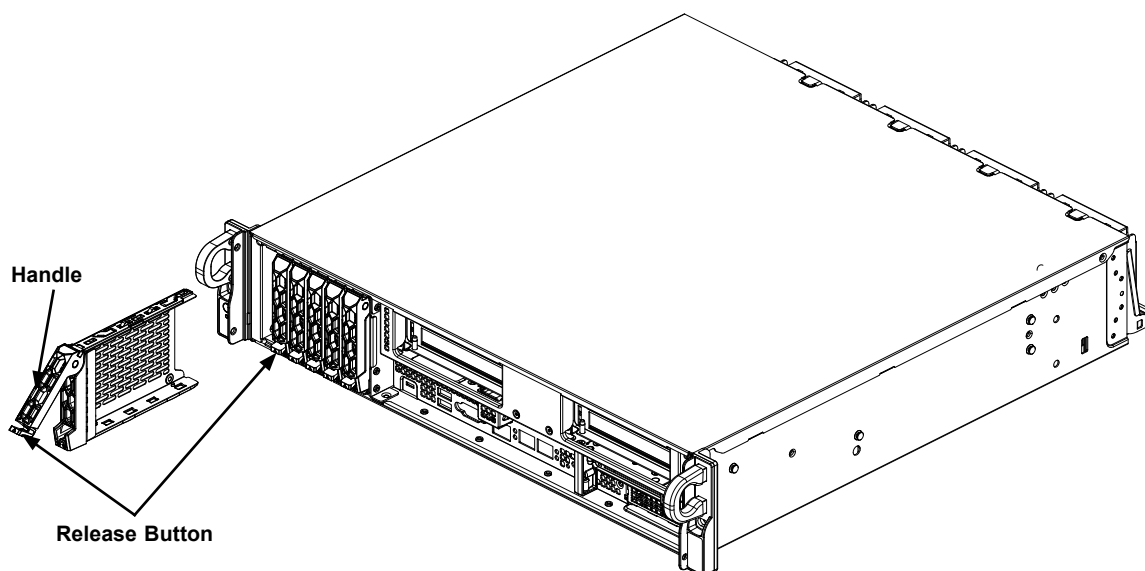

**Figure 3-3. Removing a Drive Carrier**

**Installing a Toolless 2.5" Storage Drive**

1. Place the empty storage drive carrier on a flat surface.
2. Retract the blue clips on the side of the carrier.
3. Insert a 2.5" storage drive at an angle into the carrier so that the mounting screw holes on the right side of the drive align with two stubs in the drive carrier. Insert this side into the drive carrier first, then push the other side into the drive carrier completely.
4. Push the blue clips back in to secure the drive. The drive should now be snug and secure in the drive tray. However as an option, a screw (included with the storage drive) may be installed underneath.
5. Use the open handle of the drive carrier to insert the drive carrier into the open drive bay. Secure the drive carrier into the drive bay by closing the drive carrier handle.

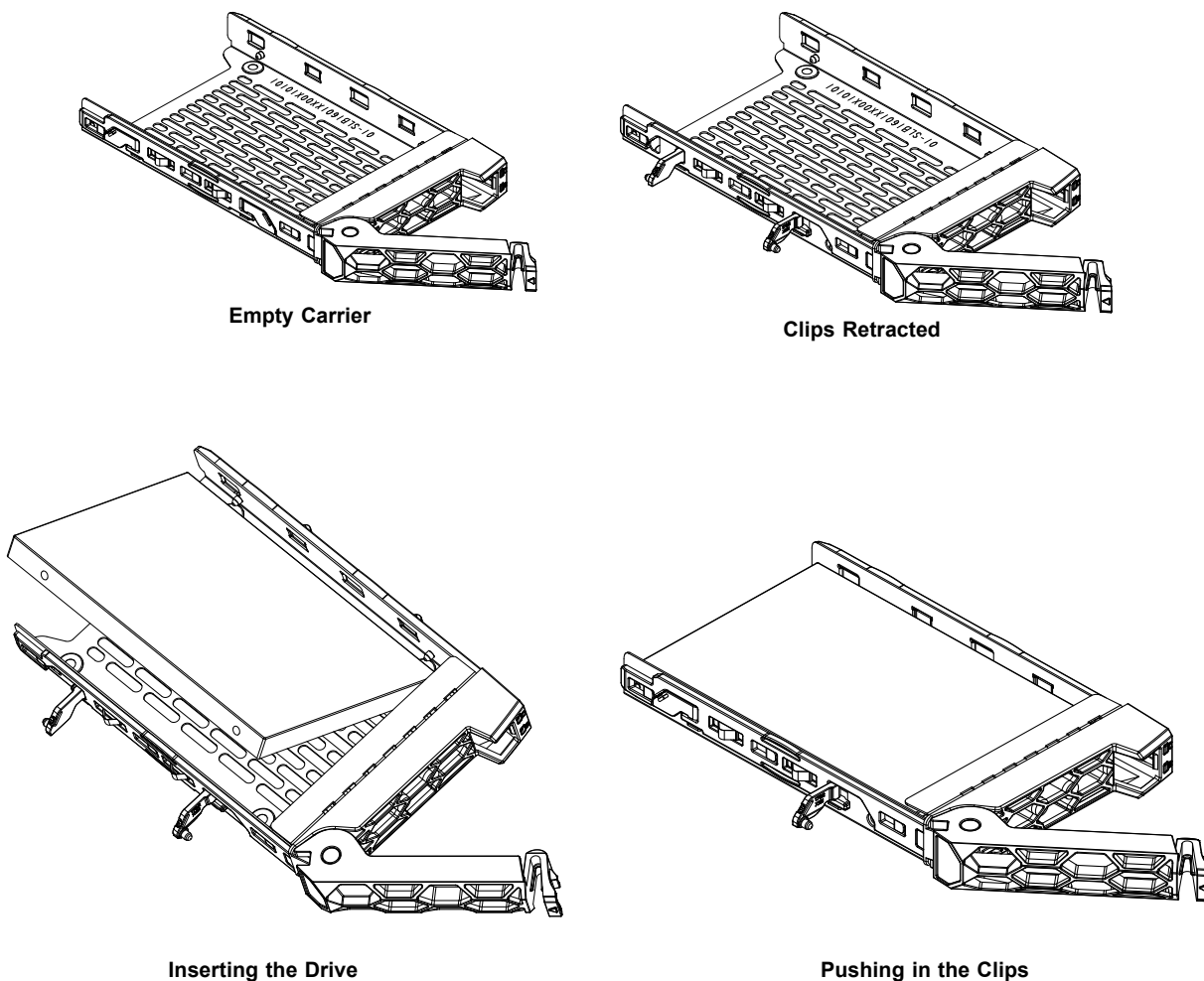
**Figure 3-4. Installing a 2.5" Storage Drive in a Carrier**

## Installing M.2 Solid State Drives

The system can accommodate one M.2 solid state drive in the 22110 form factor.

### *Installing the M.2 SSD*

**Caution:** Use industry-standard anti-static equipment, such as gloves or wrist strap, and follow precautions to avoid damage caused by ESD.

1. Pull the GPU bracket 1 out of the way.
2. For each 22x80/22x110 mm M.2 SSD, install on the standard standoff with the plastic plug.
3. Insert the SSD into the socket on the card. Then push it flat against the card and the plastic standoff.
4. Secure the SSD by firmly inserting the standoff plug.

## 3.9 Expansion Cards

The system can accommodate two low-profile and up to eight full-length, full-height PCIe cards.

### *Installing a low-profile Expansion Card*

1. Power down the system and remove the cover.
2. In the rear of the chassis, remove the blank PCIe slot assembly as shown.
3. Slide the PCIe expansion card into the PCIe slot assembly, while aligning it with the PCIe slot.
4. Replace the PCIe slot assembly with the installed expansion card onto the rear of the chassis and secure with a screw.

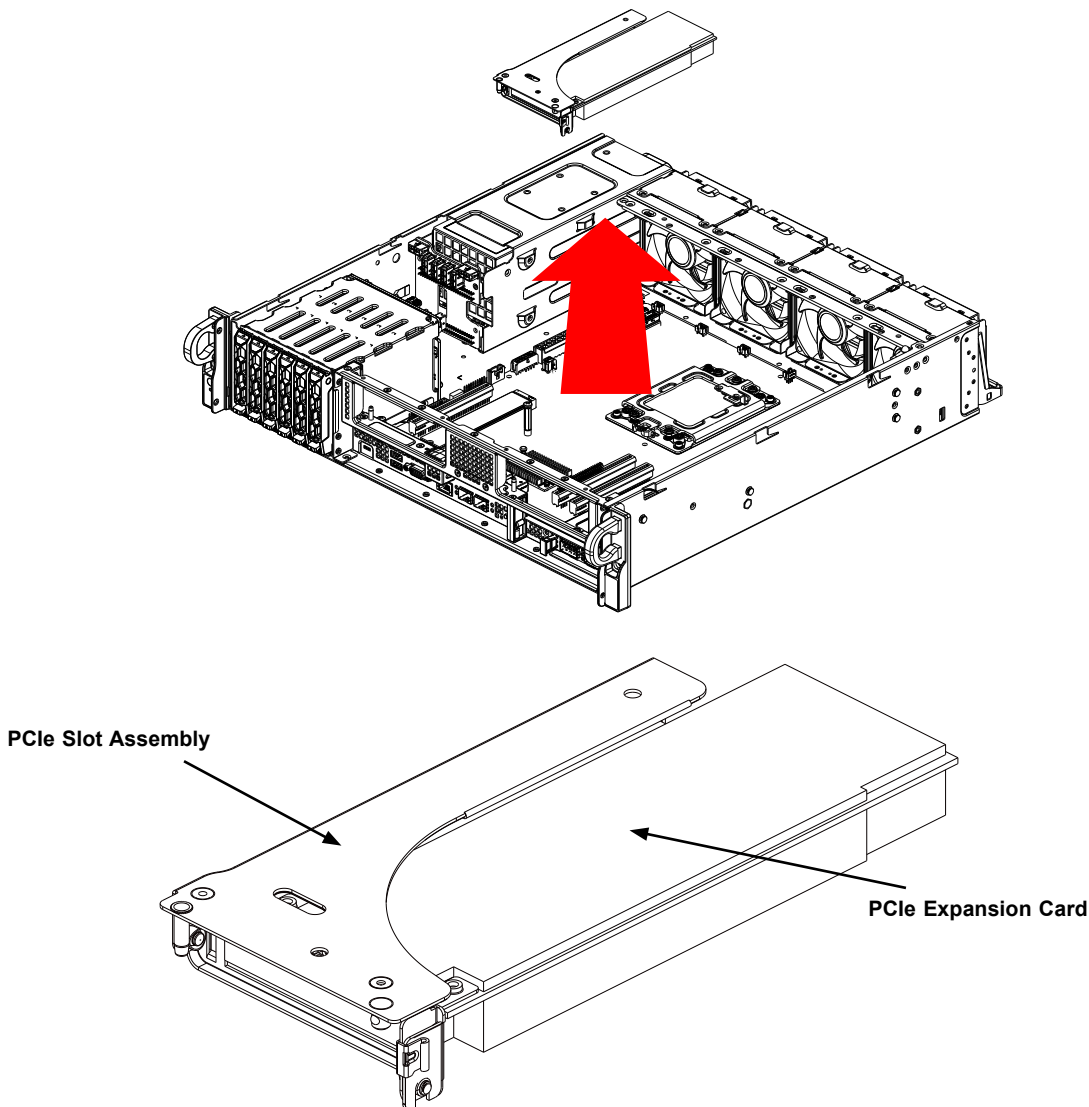

**Figure 3-5. PCIe Slot Assembly with a PCIe Expansion Card**

## 3.10 GPUs

### *Installing a GPU Expansion Card (Rear of Chassis)*

1. Power down the system and remove the cover.
2. At the rear of the chassis, remove the blank PCIe slot GPU bracket assemblies as shown.

**Note:** The DW GPU supports only bracket # 2. Ensure you retain the correct bracket for installation.

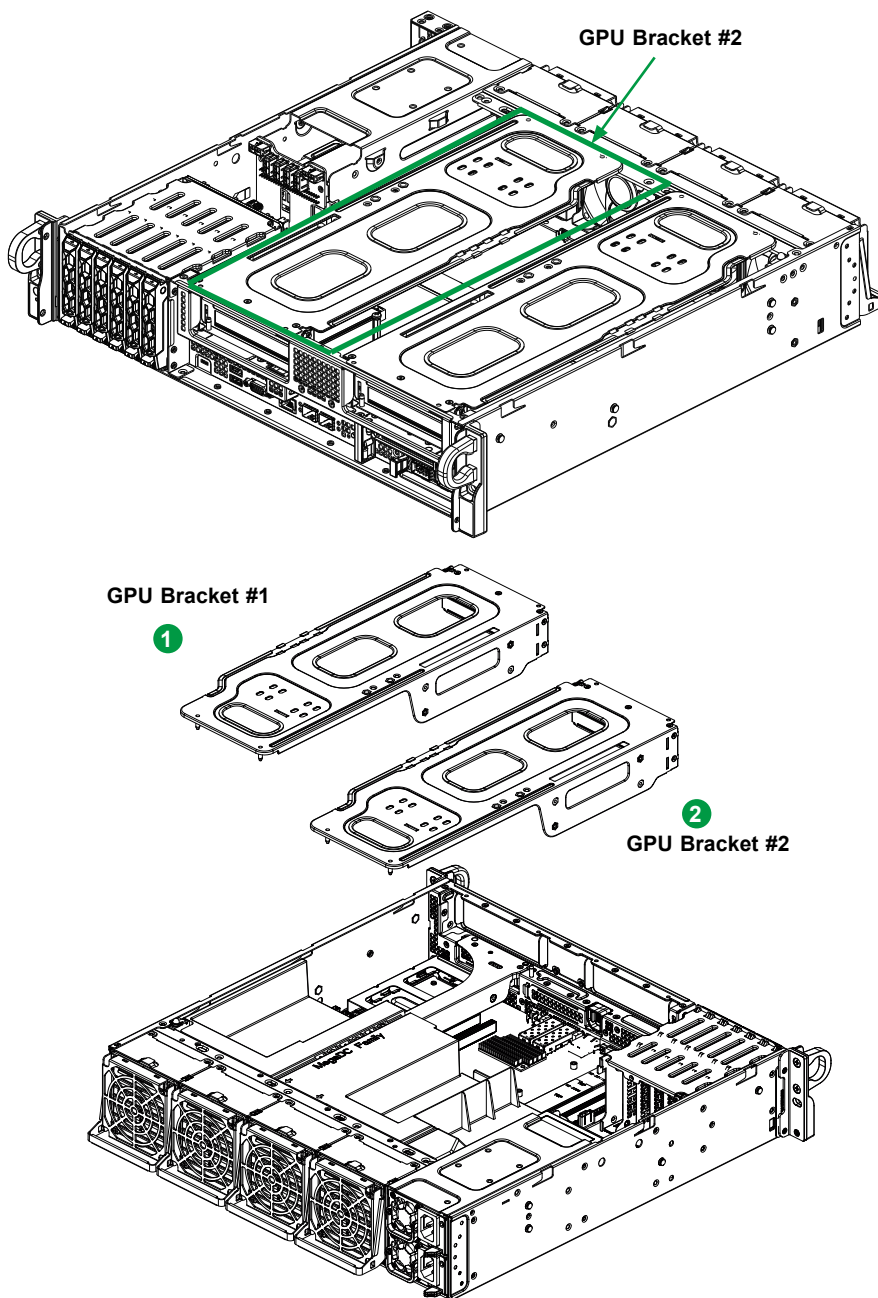
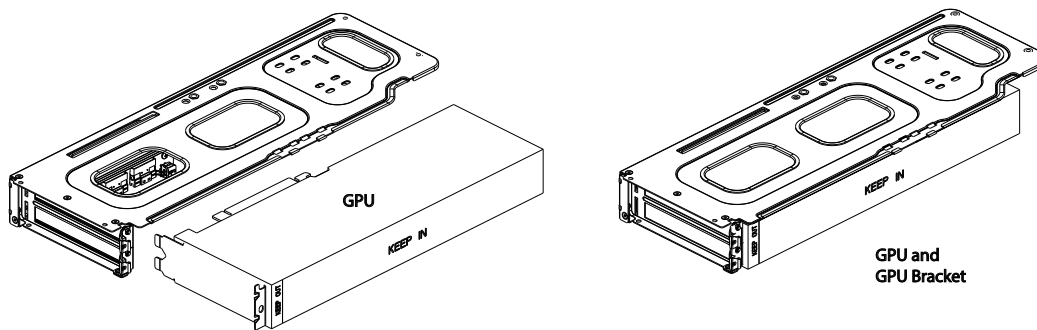
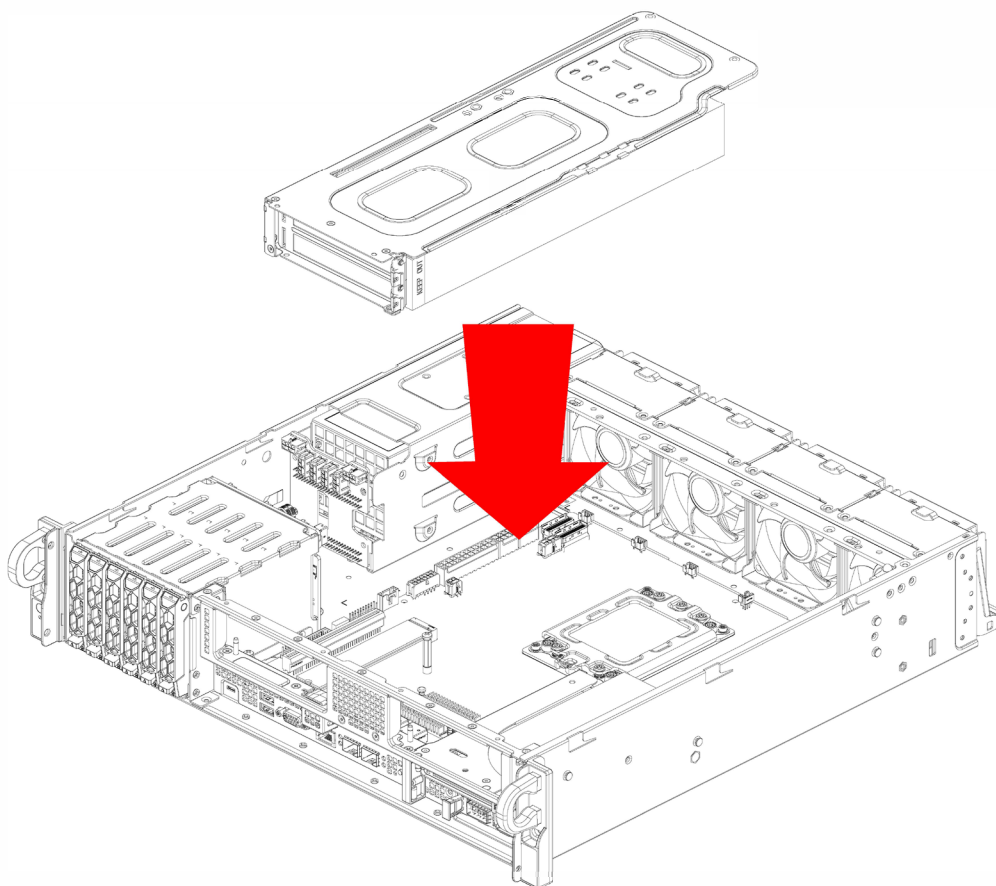

Figure 3-6. Removing the Rear PCIe/GPU Bracket Assembly

- Slide a PCIe (GPU) expansion card into the GPU bracket slot, aligning it with the PCIe slot.



- Reinstall the GPU bracket with the installed expansion card into the rear of the chassis, and secure it with a screw.



## 3.11 System Cooling

### System Fans

Four hot-swap fans provide cooling and can be replaced without powering down the system. Fan speed is controlled by a system temperature setting in IPMI. If a fan fails, the remaining fans will ramp up to full speed. The system can continue to run with a failed fan. Replace any failed fan at your earliest convenience with the same type and model.

#### *Changing a System Fan*

1. Determine which fan is failing. If possible, use IPMI. If not, remove the top and front chassis cover while the power is on, and examine the fans to determine which one has failed.
2. Pull the fan out of the chassis.
3. Place the replacement fan into the vacant space in the housing while making sure the arrows on the top of the fan (indicating air direction) point in the same direction as the arrows on the other fans.
4. Confirm that the fan is working properly before replacing the chassis cover.

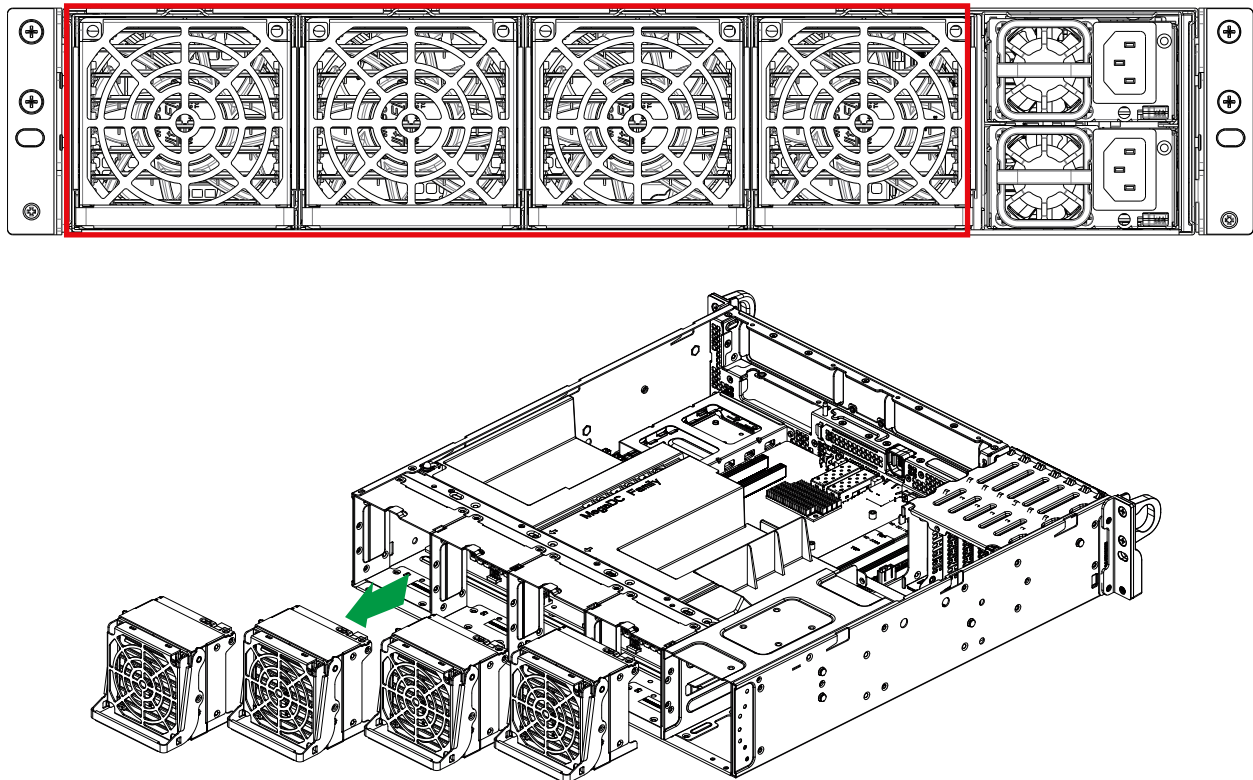

**Figure 3-7. System Fan Placement**

## Air Shrouds

An air shroud concentrates airflow to maximize fan efficiency. It covers the processors and heatsinks.

### *Installing the Air Shroud*

The air shroud fits on top of the motherboard. Align the pins and press the plastic air shroud into the chassis along the edges.

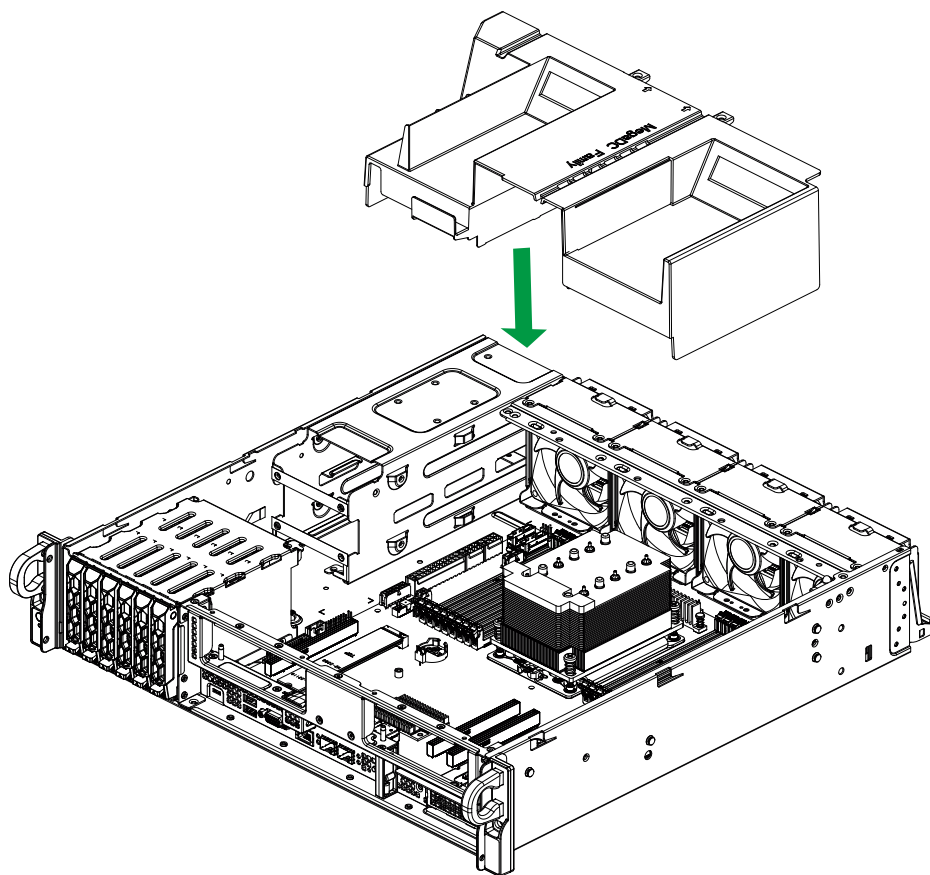

**Figure 3-8. Installing the Air Shroud**

### *Checking the Airflow*

- Make sure there are no objects obstructing the airflow in and out of the chassis.
- Make sure no wires or foreign objects obstruct airflow through the chassis. Pull all excess cabling out of the airflow path or use shorter cables.

## 3.12 Power Supply

The system features redundant power supplies. The power modules can be changed without powering down the system. New units can be ordered directly from Supermicro or authorized distributors.

These power supplies are auto-switching capable. This feature enables them to automatically sense the input voltage and operate at a 100-120 V or 180-240 V. An amber light will be illuminated on the power supply when the power is off. An illuminated green light indicates that the power supply is operating.

### ***Replacing the Power Supply***

1. Unplug the AC cord from the module to be replaced.
2. Push the release tab on the back of the power supply as illustrated.

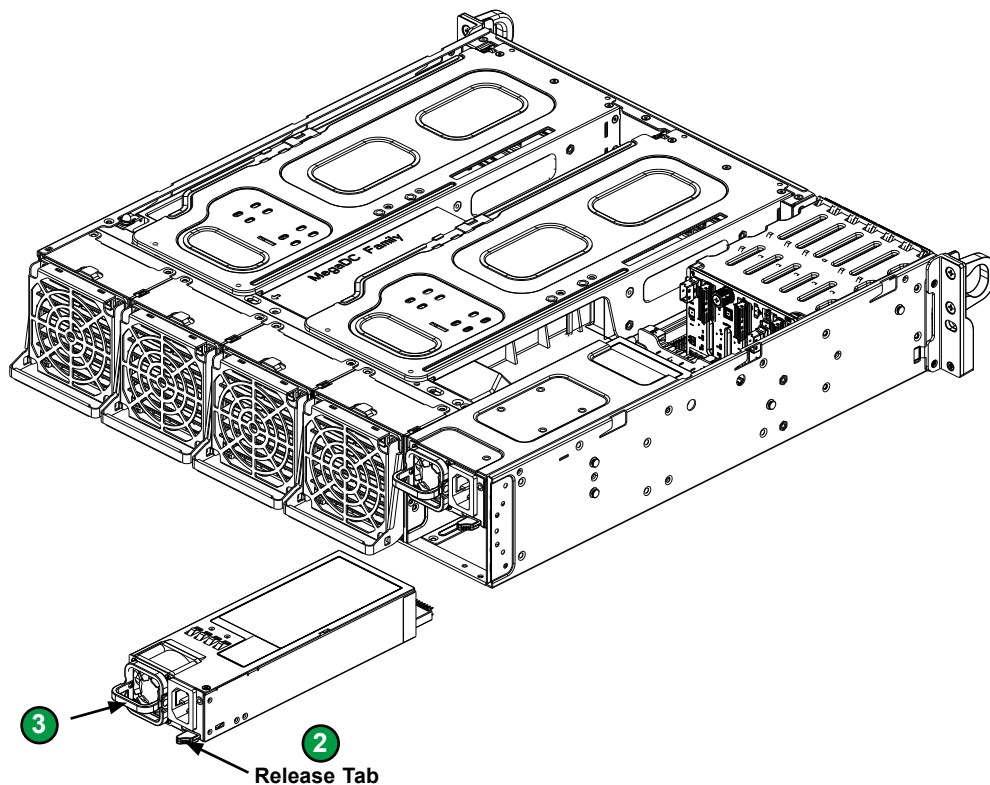

**Figure 3-9. Replacing a Power Supply Module**

3. Pull the power supply out using the handle.
4. Replace the failed power module with another of the same model.
5. Push the new power supply module into the power bay until it clicks.
6. Plug the AC power cord back into the module.

## Chapter 4

# Motherboard Connections

This section describes the connections on the motherboard and provides pinout definitions. Note that depending on how the system is configured, not all connections are required. The LEDs on the motherboard are also described here. A motherboard layout indicating component locations may be found in [Chapter 1](#). More detail can be found in the [Motherboard Manual](#). Please review the Safety Precautions in [Appendix A](#) before installing or removing components.

### 4.1 Power Connections

#### Proprietary PSU 14-Pin Power Connector

JPWR1 is a proprietary PSU 14-pin power supply connector. This power connection is required.

Proprietary PSU 14-pin Connector Pin Definitions			
Pin#	Definition	Pin#	Definition
7	PWROK	14	PS_ON_N
6	Ground	13	+12 V Standby
5	Ground	12	+12 V
4	Ground	11	+12 V
3	Ground	10	+12 V
2	Ground	9	+12 V
1	Ground	8	+12 V

### Proprietary PSU 8-Pin Power Connectors

JPWR3 and JPWR11 are proprietary 8-pin power supply connectors. These power connections are required.

Proprietary PSU 8-pin Connector Pin Definitions	
Pin#	Definition
1 – 4	Ground
5 – 8	+12 V

#### Required Connection

### Power Connector for Special Riser Card

JPWR7 is a 5 V/12 V 4-pin power connector for riser cards.

Special Riser Card Power Pin Definitions	
Pin#	Definition
1	Ground
2	Ground
3	+12 V
4	+5 V

## 4.2 Headers and Connectors

### Fan Headers

There are six 6-pin fan headers on the motherboard. Although pins 1-3 of the fan headers are backward compatible with traditional 3-pin fans, use fans with support for Pulse Width Modulation to allow the fan speeds to be automatically adjusted based on the motherboard temperature.

6-pin Fan Header Pin Definitions	
Pin#	Definition
1	Ground (Black)
2	2.5 A/+12 V (Red)
3	Tachometer
4	PWM_Control
5	2.5 A/+12 V (Red)
6	Ground (Black)

### Chassis Intrusion

A Chassis Intrusion header is located at JL1 on the motherboard. Attach the appropriate cable from the chassis to inform you of a chassis intrusion when the chassis is opened. Refer to the table below for pin definitions.

Chassis Intrusion Pin Definitions	
Pin#	Definition
1	Intrusion Input
2	Ground

#### 4-Pin BMC External I2C Header

A System Management Bus header for IPMI 2.0 is located at JIPMB1. Connect the appropriate cable here to use the IPMB I<sup>2</sup>C connection on your system. Refer to the table below for pin definitions.

External I <sup>2</sup> C Header Pin Definitions	
Pin#	Definition
1	Data
2	Ground
3	Clock
4	3V3_STBY

#### M.2 M-Key PCIe 5.0 Connector (2280/22110)

The motherboard has one M.2 slot at JM1. M.2 was formerly known as Next Generation Form Factor (NGFF) and serves to replace mini PCIe. M.2 allows for a variety of card sizes, increased functionality, and spatial efficiency. JM1 supports an M-Key PCIe 5.0 device in the 2280 and 22110 form factors.

#### PCIe 5.0 x16 AIOM Slot for an OCP 3.0 Mezzanine Card

The motherboard features one Advanced I/O Module (AIOM) PCIe 5.0 x16 slot, which can connect to an OCP 3.0 mezzanine card. Visit the Supermicro website for all available module options. Power must be unplugged prior to removing or installing an AIOM module card.

#### PCIe 5.0 x8 MCIO Connectors for NVMe

There are six Mini Cool Edge IO (MCIO) connectors located at NVMe1 – NVMe6 to support six PCIe 5.0 x8 NVMe connections. These connectors provide high-speed and low-latency connections via direct PCIe interfaces from the processor to NVMe solid state drives (SSDs). By simplifying driver/software requirements, this greatly increases SSD data-throughput performance and significantly reduces PCIe latency.

### Power Supply SMBus I2C Header

The Power System Management Bus connector (JPI2C1) monitors the power supply, fan, and system temperatures.

Power Supply SMBus Header Pin Definitions	
Pin#	Definition
1	Clock
2	Data
3	PMBUS_Alert
4	Ground
5	+3.3 V

### Trusted Platform Module (TPM)

A Trusted Platform Module (TPM) header is located at JTPM1 to provide TPM support. Use this header to enhance system performance and data security. Refer to the table below for pin definitions. Please go to the following link for more information on the TPM: <https://www.supermicro.com/manuals/other/TPM.pdf>.

Trusted Platform Module Header Pin Definitions			
Pin#	Definition	Pin#	Definition
1	+3.3 V	2	SPI_CS#
3	RESET#	4	SPI_MISO
5	SPI_CLK	6	GND
7	SPI_MOSI	8	NC
9	+3.3 V Stdby	10	SPI_IRQ#

### Universal Serial Bus (USB) Header

The motherboard has one front-accessible USB 3.0 header (USB3/4) and one front-accessible USB 2.0 header (USB5/6). The onboard headers can be used to provide front-side USB access with a cable.

Front-Accessible USB3/4 (3.0) Header Pin Definitions			
Pin#	Definition	Pin#	Definition
1	VBUS	11	IntA_P2_D+
2	IntA_P1_SSRX-	12	IntA_P2_D-
3	IntA_P1_SSRX+	13	Ground
4	Ground	14	IntA_P2_SSTX+
5	IntA_P1_SSTX-	15	IntA_P2_SSTX-
6	IntA_P1_SSTX+	16	Ground
7	Ground	17	IntA_P2_SSRX+
8	IntA_P1_D-	18	IntA_P2_SSRX-
9	IntA_P2_D+	19	VBus
10	ID		

Front-Accessible USB5/6 (2.0) Header Pin Definitions			
Pin#	Definition	Pin#	Definition
1	+5 V	2	+5 V
3	USBCON_N5	4	USBCON_N6
5	USBCON_P5	6	USBCON_P5
7	Ground	8	Ground
9	Key	10	NC

### Front Control Panel

JF1 contains header pins for various buttons and indicators that are normally located on a control panel at the front of the chassis. These connectors are designed specifically for use with Supermicro chassis. See the figure below for the descriptions of the front control panel buttons and LED indicators.

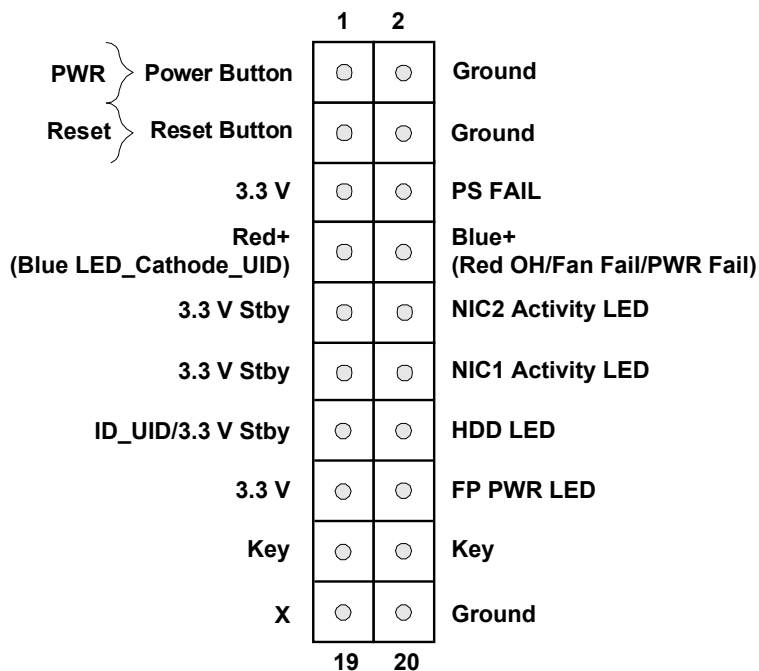

Figure 4-1. JF1 Header Pins

### Power Button

The Power Button connection is located on pins 1 and 2 of JF1. Momentarily contacting both pins will power on/off the system. Refer to the table below for pin definitions.

Power Button Pin Definitions (JF1)	
Pin#	Definition
1	Signal
2	Ground

### Reset Button

The Reset Button connection is located on pins 3 and 4 of JF1. Attach it to a hardware reset switch on the computer case to reset the system. Refer to the table below for pin definitions.

Reset Button Pin Definitions (JF1)	
Pin#	Definition
3	Reset
4	Ground

### Power Supply Fail LED

The Power Supply Fail LED connection is located on pins 5 and 6 of JF1. Refer to the table below for pin definitions.

PS Fail LED Pin Definitions (JF1)	
Pins	Definition
5	3.3 V
6	PS FAIL

### Red/Blue LED

The Red/Blue LED connection is located on pins 7 and 8 of JF1. Connect a red or blue LED across the headers to achieve the desired function. Refer to the table below for pin definitions.

Red/Blue LED Pin Definitions (JF1)	
Pins	Definition
7	Red+/Blue-
8	Blue+/Red-

**NIC1/NIC2 (LAN1/LAN2)**

The Network Interface Controller (NIC) LED connection for LAN port 1 is located on pins 11 and 12 of JF1, and LAN port 2 is on pins 9 and 10. Attach the NIC LED cables here to display network activity. Refer to the table below for pin definitions.

<b>NIC1/NIC2 LED Pin Definitions (JF1)</b>	
<b>Pins</b>	<b>Definition</b>
9	3.3 V Stby
10	NIC 2 Activity LED
11	3.3 V Stby
12	NIC 1 Activity LED

**HDD LED**

The HDD LED connection is located on pins 13 and 14 of JF1. Attach a cable to pins 13 and 14 to show storage drive activity status. Refer to the table below for pin definitions.

<b>HDD LED Pin Definitions (JF1)</b>	
<b>Pins</b>	<b>Definition</b>
13	3.3 V
14	HDD Active

**Power LED**

The Power LED connection is located on pins 15 and 16 of JF1. Refer to the table below for pin definitions.

<b>Power LED Pin Definitions (JF1)</b>	
<b>Pins</b>	<b>Definition</b>
15	3.3 V Stby
16	PWR LED

### 4.3 Input/Output Ports

See figure below for the locations and descriptions of the various I/O ports on the I/O panel of the motherboard.

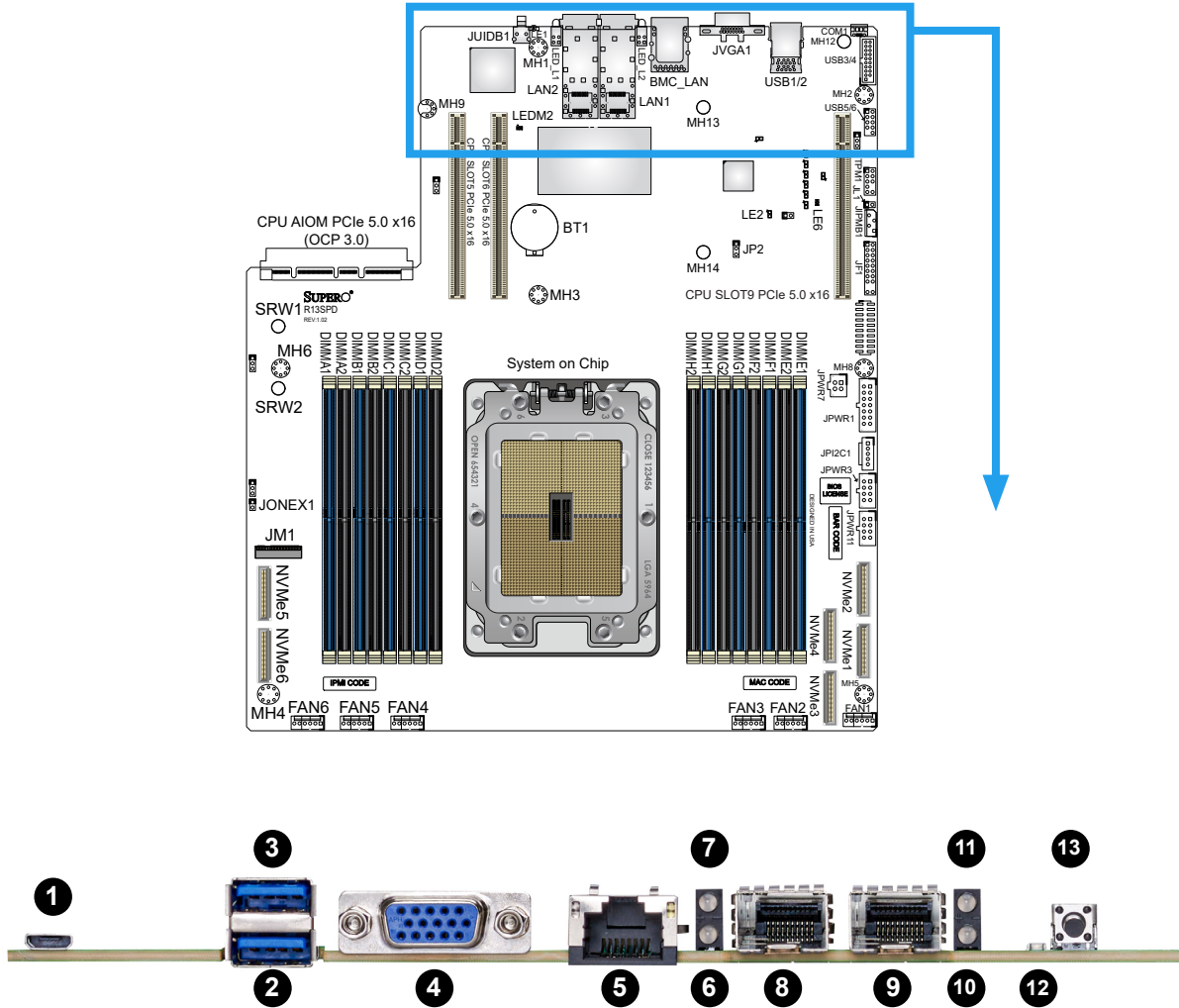

Figure 4-2. I/O Port Locations and Definitions

Rear I/O Ports					
#	Description	#	Description	#	Description
1	COM Port	6	SFP28 Traffic LED	11	SFP28 Link Speed LED
2	USB 3.0 Type-A	7	SFP28 Link Speed LED	12	UID LED
3	USB 3.0 Type-A	8	SFP28 Port	13	UID Button
4	VGA Port	9	SFP28 Port		
5	RJ45 BMC LAN Port	10	SFP28 Traffic LED		

### Dedicated BMC LAN Port

A dedicated BMC LAN port is near the VGA port on the rear I/O ports.

BMC LAN Pin Definition			
Pin#	Definition	Pin#	Definition
1	D1+	11	D4-
2	D1-	12	CT4
3	CT1	13	Yellow LED- (Activity)
4	D2+	14	Yellow LED+ (Activity)
5	D2-	15	Amber LED+ (1 GbE Link)/Green LED-
6	CT2	16	Green LED+ (100 MbE Link)/Amber LED+
7	D3+	17	CG1
8	D3-	18	CG2
9	CT3	19	CG3
10	D4-	20	CG4

### VGA Port

A video (VGA) port is included with the rear I/O ports.

### SFP28 10G/25G LAN Ports

Two SFP28 LAN ports (LAN1 and LAN2) are included with the rear I/O ports. These LAN ports are provided by the Broadcom NetXtreme-E Series BCM57414 and can function as either one 25 G port or two 10 G ports. Refer to the LED Indicator section for SFP28 LED information.

### USB 3.0 Type-A Ports on the Rear I/O Ports

There are two USB 3.0 Type-A ports (USB2/3) included with the rear I/O ports.

Rear I/O Ports USB2/3 (3.0) Pin Definitions			
Pin#	Definition	Pin#	Definition
B1	VBUS	B5	Stda_SSRX2-
B2	D2-	B6	Stda_SSRX2+
B3	D2+	B7	GND_DRAIN
B4	GND	B8	Stda_SSTX2-
		B9	Stda_SSTX2+
A1	VBUS	A5	Stda_SSRX1-
A2	D1-	A6	Stda_SSRX1+
A3	D1+	A7	GND_DRAIN
A4	GND	A8	Stda_SSTX1-
		A9	Stda_SSTX1+

### Unit Identifier Switch/UID LED Indicator

A Unit Identifier (UID) switch and an LED Indicator are located on the motherboard. The UID switch is located at UID on the I/O panel. The UID LED is located next to the UID switch. When you press the UID switch, and the UID/Reset Button Switch header at JP is set to UID Select, the UID LED will be turned on. Press the UID switch again to turn off the LED indicator. The UID Indicator provides easy identification of a system unit that may be in need of service.

**Note:** UID can also be triggered via IPMI on the motherboard. For more information on IPMI, refer to the IPMI User's Guide posted on our website at <https://www.supermicro.com/support/manuals/>.

UID Switch Pin Definitions	
Pin#	Definition
1	Ground
2	Ground
3	Button In
4	Button In

UID LED Pin Definitions	
Color	Status
Blue: On	Unit Identified

### Micro USB COM Port

The Micro USB COM port baud rate is fixed to 115200 and supports read/write. To access the Micro USB COM port, ensure the host system has a CP2102 USB-to-UART bridge driver. Attach a keyboard to the R13SPD motherboard for input. The CPU UART can output UEFI and OS to console.

## 4.4 Jumpers

### Explanation of Jumpers

To modify the operation of the motherboard, jumpers are used to choose between optional settings. Jumpers create shorts between two pins to change the function of the connector. Pin 1 is identified with a square solder pad on the printed circuit board. See the diagram below for an example of jumping pins 1 and 2. Refer to the motherboard layout page for jumper locations.

**Note:** On two-pin jumpers, "Closed" means the jumper is on and "Open" means the jumper is off the pins.

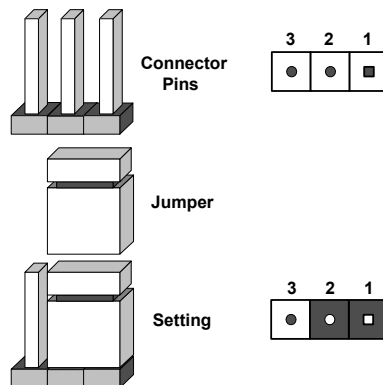

### UID/Reset Button Switch

Jumper JP2 controls the function of the UID/Reset Button. Refer to the table below for jumper settings. The default setting is UID.

UID/Reset Button Switch Jumper Settings	
Jumper Setting	Definition
Pins 1–2	Reset Button
Pins 2–3	UID Button (Default)

### AmpereOne AC03/AmpereOne AC04 Voltage

Change the setting of jumper JONEX1 to change CPU EXT\_VREF\_S0 from 0.7 V to 0.6 V to use an AmpereOne AC03/AC04 processor. The default setting is Open for 0.7 V to use an AmpereOne AC04 processor.

AmpereOne AC03/AmpereOne AC04 Voltage Jumper Settings	
Jumper Setting	Definition
Pins 1–2 Open	AmpereOne AC03
Pins 1–2 Closed	AmpereOne AC04 (Default)

## 4.5 LED Indicators

### System Status LED

LED6 is the system status LED for the motherboard. When the system is plugged into power, LED6 will indicate the status of the system.

System Status LED	
Color/State	Definition
Solid Red	Standby
Solid Green	System Power

### BMC Heartbeat LED

LEDM2 is the BMC Heartbeat LED. When the LED is blinking green, BMC is working.

BMC Heartbeat LED	
Color/State	Definition
Blinking Green	BMC Normal

### SFP28 LAN Status for LAN1

LED\_L1 is two LEDs that indicate the status of LAN2. The top LED indicates link speed and the bottom LED indicates LAN1 port activity.

SFP28 LAN Status for LAN1		
LED	Color/State	Definition
Top LED	Yellow	10G Link
Top LED	Green	25G Link
Bottom LED	Green	Port Activity

### SFP28 LAN Status for LAN2

LED\_L2 is two LEDs that indicate the status of LAN1. The top LED indicates link speed and the bottom LED indicates LAN2 port activity.

SFP28 LAN Status for LAN2		
LED	Color/State	Definition
Top LED	Yellow	10G Link
Top LED	Green	25G Link
Bottom LED	Green	Port Activity

---

---

# Chapter 5

## Software

After the hardware has been installed, you can install the Operating System (OS), configure RAID settings, and install the drivers.

### 5.1 Ubuntu OS Installation

If you will be using RAID, you must configure RAID settings before installing the RAID driver. Refer to the RAID Configuration User Guides posted on our website at [www.supermicro.com/support/manuals](http://www.supermicro.com/support/manuals).

#### *Installing the OS*

We recommend you to follow the Ubuntu installation instructions. Go to the following link for more information on the Ubuntu website: <https://ubuntu.com/server/docs/how-to>

### 5.2 BMC

The R13SPD support the Baseboard Management Controller (BMC). BMC is used to provide remote access, monitoring and management. There are several BIOS settings that are related to BMC.

For general documentation and information on BMC, please visit our website at:

<http://www.supermicro.com/products/nfo/BMC.cfm>.

### 5.3 Logging into the BMC (Baseboard Management Controller)

Supermicro ships standard products with a unique password for the BMC ROOT user. This password can be found on a label on the motherboard and the rear window.

When logging in to the BMC for the first time, please use the unique password provided by Supermicro to log in. You can change the unique password to a user name and password of your choice for subsequent logins.



**Figure 5-1. BMC Password Label**

## Chapter 6

# Troubleshooting and Support

## 6.1 Information Resources

### Website

A great deal of information is available on the Supermicro [website](#).

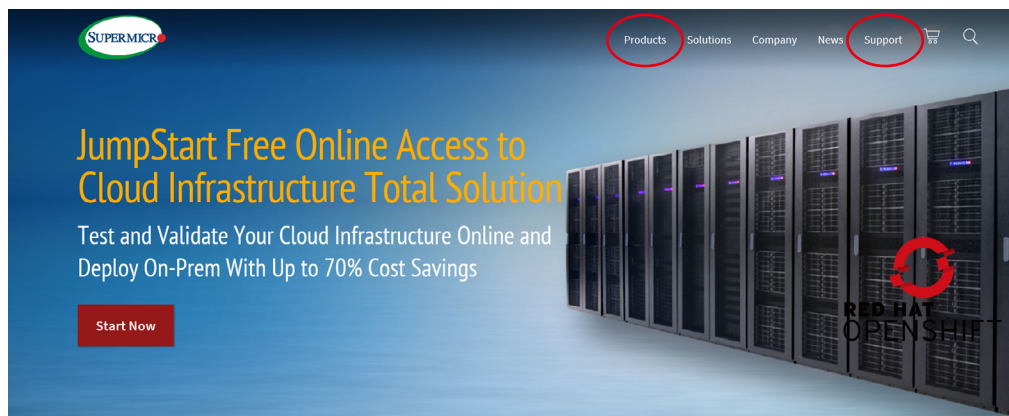

Figure 6-1. Supermicro Website

- Specifications for servers and other hardware are available by clicking **Products**.
- The **Support** option offers downloads (manuals, BIOS/BMC, drivers, etc.), FAQs, RMA, warranty, and other service extensions.

### ***Direct Links for the ARS-211ME-FNR System***

See the website specifications pages: [ARS-211ME-FNR](#), and [R13SPD](#) motherboard page for links to the Quick Reference Guide, User Manual, validated storage drives, etc.

### ***Direct Links for General Support and Information***

[Frequently Asked Questions](#)

[TPM User Guide](#)

### ***Direct Links (continued)***

For validated memory, see our [Product Resources page](#)

[Product Matrices](#) page for links to tables summarizing specs for systems, motherboards, power supplies, riser cards, add-on cards, etc.

[Security Center](#) for recent security notices

[Supermicro Phone and Addresses](#)

## **6.2 Troubleshooting Procedures**

Use the following procedures to troubleshoot your system. If you have followed all of the procedures below and still need assistance, refer to the [Technical Support Procedures](#) or [Returning Merchandise for Service](#) section(s) in this chapter. Always disconnect the AC power cables before adding, changing or installing any non hot-swap hardware components.

### **Before Power On**

1. Make sure that there are no short circuits between the motherboard and the chassis.
2. Disconnect all ribbon/wire cables from the motherboard, including those for the keyboard and mouse.
3. Remove all add-on cards.
4. Install the CPU (making sure it is fully seated) and connect the front panel connectors to the motherboard.

### **No Power**

1. Make sure that there are no short circuits between the motherboard and the chassis.
2. Make sure that the ATX power connectors are properly connected.
3. Check that the 115 V/230 V switch, if available, on the power supply is properly set.
4. Turn the power switch on and off to test the system, if applicable.
5. The battery on your motherboard may be old. Check to verify that it still supplies approximately 3 VDC. If it does not, replace it with a new one.

## No Video

1. If the power is on, but you have no video, remove all add-on cards and cables.
2. Use the speaker to determine if any beep codes are present. Refer to [Appendix A](#) for details on beep codes.
3. Remove all memory modules and turn on the system. If the alarm is on, check the specs of memory modules, reset the memory or try a different one.

## System Boot Failure

If the system does not display POST (Power-On-Self-Test) or does not respond after the power is turned on, check the following:

1. Check for any error beep from the motherboard speaker.
  - If there is no error beep, try to turn on the system without DIMM modules installed. If there is still no error beep, replace the motherboard.
  - If there are error beeps, clear the CMOS settings by unplugging the CMOS battery located at BT1 and holding the power button for at least five seconds.
2. Remove all components from the motherboard, especially the DIMM modules. Power on the system and check if the power-on LED (LED2) and the BMC Heartbeat LED (LEDM1) are on, and system fans are spinning.
3. Turn on the system with only one DIMM module installed. If the system boots, check for bad DIMM modules or slots by following the Memory Errors Troubleshooting procedure in this chapter.

## Memory Errors

When a no-memory beep code is issued by the system, check the following:

1. Make sure that the memory modules are compatible with the system and are properly installed. See [Chapter 2](#) for installation instructions. (For memory compatibility, refer to the "Tested Memory List" link on the motherboard's product page to see a list of supported memory.)
2. Check if different speeds of DIMMs have been installed. It is strongly recommended that you use the same RAM type and speed for all DIMM modules in the system.
3. Make sure that you are using the correct type of ECC RDIMM/3DS RDIMM DDR5 modules recommended by the manufacturer.

4. Check for bad DIMM modules or slots by swapping a single module among all memory slots and check the results.

## Losing the System's Setup Configuration

1. Make sure that you are using a high-quality power supply. Always replace power supplies with the exact same model that came with the system. A poor quality power supply may cause the system to lose the CMOS setup configuration.
2. The battery on your motherboard may be old. Check to verify that it still supplies approximately 3 VDC. If it does not, replace it with a new one.
3. If the above steps do not fix the setup configuration problem, contact your vendor for repairs.

## If the System Becomes Unstable

### ***A. If the system becomes unstable during or after OS installation, check the following:***

1. CPU/BIOS support: Make sure that your CPU is supported and that you have the latest BIOS installed in your system.
2. Memory support: Make sure that the memory modules are supported by testing the modules with a memory test utility.

**Note:** Click on the "Tested Memory List" link on the motherboard's product page to see a list of supported memory.

3. Storage drive support: Make sure that all storage drives work properly. Replace the failed storage drives with good ones.
4. System cooling: Check the system cooling to make sure that all heatsink fans and CPU/system fans, etc., work properly. Also check the front panel Overheat LED and make sure that it is not on.
5. Adequate power supply: Make sure that the power supply provides adequate power to the system. Make sure that all power connectors are connected. Refer to our website for more information on the minimum power requirements.
6. Proper software support: Make sure that the correct drivers are used.

***B. If the system becomes unstable before or during OS installation, check the following:***

1. Source of installation: Make sure that the devices used for installation are working properly, including boot devices such as CD/Media drive.
2. Cable connection: Check to make sure that all cables are connected and working properly.
3. Use the minimum configuration for troubleshooting: Remove all unnecessary components (starting with add-on cards first), and use the minimum configuration (but with the CPU and a memory module installed) to identify the trouble areas. Refer to the steps listed in Section A above for proper troubleshooting procedures.
4. Identifying bad components by isolating them. If necessary, remove a component in question from the chassis, and test it in isolation to make sure that it works properly. Replace a bad component with a good one.
5. Check and change one component at a time instead of changing several items at the same time. This will help isolate and identify the problem.
6. To find out if a component is good, swap this component with a new one to see if the system will work properly. If so, then the old component is bad. You can also install the component in question in another system. If the new system works, the component is good and the old system has problems.

## 6.3 Technical Support Procedures

Before contacting Technical Support, please take the following steps. Also, note that as a motherboard manufacturer, Supermicro also sells motherboards through its channels, so it is best to first check with your distributor or reseller for troubleshooting services. They should know of any possible problems with the specific system configuration that was sold to you.

1. Go through the Troubleshooting Procedures and Frequently Asked Questions (FAQ) sections in this chapter or see the FAQs on our website (<http://www.supermicro.com/FAQ/index.php>) before contacting Technical Support.
2. BIOS upgrades can be downloaded from our website ([http://www.supermicro.com/ResourceApps/BIOS\\_BMC\\_Intel.html](http://www.supermicro.com/ResourceApps/BIOS_BMC_Intel.html)).

3. If you still cannot resolve the problem, include the following information when contacting Supermicro for technical support:
  - Motherboard model and PCB revision number
  - BIOS release date/version (This can be seen on the initial display when your system first boots up.)
  - System configuration
4. An example of a Technical Support form is on our website at <http://www.supermicro.com/RmaForm/>.
5. Distributors: For immediate assistance, please have your account number ready when placing a call to our Technical Support department. We can be reached by email at [support@supermicro.com](mailto:support@supermicro.com).

## 6.4 Frequently Asked Questions

### **Question: What type of memory does my motherboard support?**

**Answer:** The R13SPD motherboard supports 8 TB of DDR5 ECC RDIMM/3DSRDIMM memory with speeds of up to up to 4800 MT/s in 16 memory slots. To enhance memory performance, do not mix memory modules of different speeds and sizes. Follow all memory installation instructions given on [Section 3.6](#) in Chapter 3.

### **Question: How do I update my BIOS?**

**Answer:** It is recommended that you do not upgrade your BIOS if you are not experiencing any problems with your system. Updated BIOS files are located on our website at [http:// www.supermicro.com/ResourceApps/BIOS\\_IPMI\\_Intel.html](http://www.supermicro.com/ResourceApps/BIOS_IPMI_Intel.html). Check our BIOS warning message and the information on how to update your BIOS on our website. Select your motherboard model and download the BIOS file to your computer. Also, check the current BIOS revision to make sure that it is newer than your BIOS before downloading. Unzip the BIOS file onto a bootable USB device. Run the batch file using the format FLASH.BAT filename.rom from your bootable USB device to flash the BIOS. Then, your system will automatically reboot.

**Warning:** Do not shut down or reset the system while updating the BIOS to prevent possible system boot failure!

**Note:** The SPI BIOS chip used on this motherboard cannot be removed. Send your motherboard back to our RMA Department at Supermicro for repair. For BIOS Recovery instructions, refer to the AMI BIOS Recovery Instructions posted at <https://www.supermicro.com/support/manuals/>.

## 6.5 Returning Merchandise for Service

A receipt or copy of your invoice marked with the date of purchase is required before any warranty service will be rendered. You can obtain service by calling your vendor for a Returned Merchandise Authorization (RMA) number. When returning the motherboard to the manufacturer, the RMA number should be prominently displayed on the outside of the shipping carton, and the shipping package is mailed prepaid or hand-carried. Shipping and handling charges will be applied for all orders that must be mailed when service is complete. For faster service, you can also request a RMA authorization online (<https://www.supermicro.com/RmaForm/>).

This warranty only covers normal consumer use and does not cover damages incurred in shipping or from failure due to the alternation, misuse, abuse or improper maintenance of products.

During the warranty period, contact your distributor first for any product problems.

## 6.6 Feedback

Supermicro values your feedback as we strive to improve our customer experience in all facets of our business. To provide feedback on our manuals, please email us at [techwriterteam@supermicro.com](mailto:techwriterteam@supermicro.com).

## 6.7 Contacting Supermicro

### Headquarters

Address: Super Micro Computer, Inc.  
980 Rock Ave.  
San Jose, CA 95131 U.S.A.

Tel: +1 (408) 503-8000

Fax: +1 (408) 503-8008

Email: [marketing@supermicro.com](mailto:marketing@supermicro.com) (General Information)  
[Sales-USA@supermicro.com](mailto:Sales-USA@supermicro.com) (Sales Inquiries)  
[Government\\_Sales-USA@supermicro.com](mailto:Government_Sales-USA@supermicro.com) (Gov. Sales Inquiries)  
[support@supermicro.com](mailto:support@supermicro.com) (Technical Support)  
[RMA@supermicro.com](mailto:RMA@supermicro.com) (RMA Support)  
[Webmaster@supermicro.com](mailto:Webmaster@supermicro.com) (Webmaster)

Website: [www.supermicro.com](http://www.supermicro.com)

### Europe

Address: Super Micro Computer B.V.  
Het Sterrenbeeld 28, 5215 ML  
's-Hertogenbosch, The Netherlands

Tel: +31 (0) 73-6400390

Fax: +31 (0) 73-6416525

Email: [Sales\\_Europe@supermicro.com](mailto:Sales_Europe@supermicro.com) (Sales Inquiries)  
[Support\\_Europe@supermicro.com](mailto:Support_Europe@supermicro.com) (Technical Support)  
[RMA\\_Europe@supermicro.com](mailto:RMA_Europe@supermicro.com) (RMA Support)

Website: [www.supermicro.nl](http://www.supermicro.nl)

### Asia-Pacific

Address: Super Micro Computer, Inc.  
3F, No. 150, Jian 1st Rd.  
Zhonghe Dist., New Taipei City 235  
Taiwan (R.O.C)

Tel: +886-(2) 8226-3990

Fax: +886-(2) 8226-3992

Email: [Sales-Asia@supermicro.com.tw](mailto:Sales-Asia@supermicro.com.tw) (Sales Inquiries)  
[Support@supermicro.com.tw](mailto:Support@supermicro.com.tw) (Technical Support)  
[RMA@supermicro.com.tw](mailto:RMA@supermicro.com.tw) (RMA Support)

Website: [www.supermicro.com.tw](http://www.supermicro.com.tw)

## Appendix A

# Standardized Warning Statements for AC Systems

### About Standardized Warning Statements

The following statements are industry standard warnings, provided to warn the user of situations which have the potential for bodily injury. Should you have questions or experience difficulty, contact Supermicro's Technical Support department for assistance. Only certified technicians should attempt to install or configure components.

Read this appendix in its entirety before installing or configuring components in the Supermicro chassis.

These warnings may also be found on our website at [http://www.supermicro.com/about/policies/safety\\_information.cfm](http://www.supermicro.com/about/policies/safety_information.cfm).

### Warning Definition



**Warning!** This warning symbol means danger. You are in a situation that could cause bodily injury. Before you work on any equipment, be aware of the hazards involved with electrical circuitry and be familiar with standard practices for preventing accidents.

#### 警告の定義

この警告サインは危険を意味します。

人身事故につながる可能性がありますので、いずれの機器でも動作させる前に、電気回路に含まれる危険性に注意して、標準的な事故防止策に精通して下さい。

此警告符号代表危險。

您正处于可能受到严重伤害的工作环境中。在您使用设备开始工作之前，必须充分意识到触电的危险，并熟练掌握防止事故发生的标准工作程序。请根据每项警告结尾的声明号码找到此设备的安全性警告说明的翻译文本。

此警告符號代表危險。

您正處於可能身體可能會受損傷的工作環境中。在您使用任何設備之前，請注意觸電的危險，並且要熟悉預防事故發生的標準工作程序。請依照每一注意事項後的號碼找到相關的翻譯說明內容。

## Warnung

### WICHTIGE SICHERHEITSHINWEISE

Dieses Warnsymbol bedeutet Gefahr. Sie befinden sich in einer Situation, die zu Verletzungen führen kann. Machen Sie sich vor der Arbeit mit Geräten mit den Gefahren elektrischer Schaltungen und den üblichen Verfahren zur Vorbeugung vor Unfällen vertraut. Suchen Sie mit der am Ende jeder Warnung angegebenen Anweisungsnummer nach der jeweiligen Übersetzung in den übersetzten Sicherheitshinweisen, die zusammen mit diesem Gerät ausgeliefert wurden.

BEWAHREN SIE DIESE HINWEISE GUT AUF.

### INSTRUCCIONES IMPORTANTES DE SEGURIDAD

Este símbolo de aviso indica peligro. Existe riesgo para su integridad física. Antes de manipular cualquier equipo, considere los riesgos de la corriente eléctrica y familiarícese con los procedimientos estándar de prevención de accidentes. Al final de cada advertencia encontrará el número que le ayudará a encontrar el texto traducido en el apartado de traducciones que acompaña a este dispositivo.

GUARDE ESTAS INSTRUCCIONES.

### IMPORTANTES INFORMATIONS DE SÉCURITÉ

Ce symbole d'avertissement indique un danger. Vous vous trouvez dans une situation pouvant entraîner des blessures ou des dommages corporels. Avant de travailler sur un équipement, soyez conscient des dangers liés aux circuits électriques et familiarisez-vous avec les procédures couramment utilisées pour éviter les accidents. Pour prendre connaissance des traductions des avertissements figurant dans les consignes de sécurité traduites qui accompagnent cet appareil, référez-vous au numéro de l'instruction situé à la fin de chaque avertissement.

CONSERVEZ CES INFORMATIONS.

## תקנון הזהרות אזהרה

הזהרות הבאות הן אזהרות על פי תקני התעשייה, על מנת להזהיר את המשתמש מפני חבלה פיזית אפשרית. במידה ויש שאלות או היתקלות בבעיה כלשהי, יש ליצור קשר עם מחלקת תמיכה טכנית של סופרמיקרו. טכנאים מוסמכים בלבד רשאים להתקין או להגדיר את הרכיבים. יש לקרוא את הנספח במלואו לפני התקנת או הגדרת הרכיבים במארזי סופרמיקרו.

اَكْ ف حالة وُكِي اَي تتسبب ف اصابة جسدهُ هذا الزهز عْ خطر! تحذُرُ .  
 قبل اَي تعول على اَي هعدات، كي على علن بالوخاطز ال اُجوة عي الذوائر  
 الكهزبائِة  
 وكي على دراةُ بالووارسات النقااِة لو عْ وقع اَي حادث  
 استخدم رقن الب اِى الو صُص ف هَّاةُ كل تحذُرُ للعشر تزجوتها

안전을 위한 주의사항

경고!

이 경고 기호는 위험이 있음을 알려 줍니다. 작업자의 신체에 부상을 야기 할 수 있는 상태에 있게 됩니다. 모든 장비에 대한 작업을 수행하기 전에 전기회로와 관련된 위험요소들을 확인하시고 사전에 사고를 방지할 수 있도록 표준 작업절차를 준수해 주시기 바랍니다.

해당 번역문을 찾기 위해 각 경고의 마지막 부분에 제공된 경고문 번호를 참조하십시오

## BELANGRIJKE VEILIGHEIDSINSTRUCTIES

Dit waarschuwings symbool betekent gevaar. U verkeert in een situatie die lichamelijk letsel kan veroorzaken. Voordat u aan enige apparatuur gaat werken, dient u zich bewust te zijn van de bij een elektrische installatie betrokken risico's en dient u op de hoogte te zijn van de standaard procedures om ongelukken te voorkomen. Gebruik de nummers aan het eind van elke waarschuwing om deze te herleiden naar de desbetreffende locatie.

BEWAAR DEZE INSTRUCTIES

## Installation Instructions



**Warning!** Read the installation instructions before connecting the system to the power source.

設置手順書

システムを電源に接続する前に、設置手順書をお読み下さい。

警告

将此系统连接电源前,请先阅读安装说明。

警告

將系統與電源連接前，請先閱讀安裝說明。

**Warnung**

Vor dem Anschließen des Systems an die Stromquelle die Installationsanweisungen lesen.

**¡Advertencia!**

Lea las instrucciones de instalación antes de conectar el sistema a la red de alimentación.

**Attention**

Avant de brancher le système sur la source d'alimentation, consulter les directives d'installation.

יש לקרוא את הוראות התקנה לפני חיבור המערכת למקור מתח.

اقرأ إرشادات التركيب قبل توصيل النظام إلى مصدر للطاقة

시스템을 전원에 연결하기 전에 설치 안내를 읽어주십시오.

**Waarschuwing**

Raadpleeg de installatie-instructies voordat u het systeem op de voedingsbron aansluit.

**Circuit Breaker**

**Warning!** This product relies on the building's installation for short-circuit (overcurrent) protection. Ensure that the protective device is rated not greater than: 250 V, 20 A.

**サーキット・ブレーカー**

この製品は、短絡(過電流)保護装置がある建物での設置を前提としています。

保護装置の定格が250 V、20 Aを超えないことを確認下さい。

**警告**

此产品的短路(过载电流)保护由建筑物的供电系统提供,确保短路保护设备的额定电流不大于250V,20A。

**警告**

此產品的短路(過載電流)保護由建築物的供電系統提供,確保短路保護設備的額定電流不大於250V,20A。

**Warnung**

Dieses Produkt ist darauf angewiesen, dass im Gebäude ein Kurzschluss- bzw. Überstromschutz installiert ist. Stellen Sie sicher, dass der Nennwert der Schutzvorrichtung nicht mehr als: 250 V, 20 A beträgt.

**¡Advertencia!**

Este equipo utiliza el sistema de protección contra cortocircuitos (o sobrecorrientes) del edificio. Asegúrese de que el dispositivo de protección no sea superior a: 250 V, 20 A.

**Attention**

Pour ce qui est de la protection contre les courts-circuits (surtension), ce produit dépend de l'installation électrique du local. Vérifiez que le courant nominal du dispositif de protection n'est pas supérieur à :250 V, 20 A.

מוצר זה מסתמך על הגנה המותקנת במבנים למניעת קצר חשמלי. יש לוודא כי המכשיר המגן מפני הקצר החשמלי הוא לא יותר מ-250VDC, 20A

هذا المنتج يعتمد على معدات الحماية مه الدوائر القصيرة التي تم تثبيتها في المبنى  
تأكد من أن تقييم الجهاز الوقائي ليس أكثر من : 20A, 250V

**경고!**

이 제품은 전원의 단락(과전류)방지에 대해서 전적으로 건물의 관련 설비에 의존합니다. 보호장치의 정격이 반드시 250V(볼트), 20A(암페어)를 초과하지 않도록 해야 합니다.

**Waarschuwing**

Dit product is afhankelijk van de kortsluitbeveiliging (overspanning) van uw elektrische installatie. Controleer of het beveiligde apparaat niet groter gedimensioneerd is dan 250V, 20A.

## Power Disconnection Warning



**Warning!** The system must be disconnected from all sources of power and the power cord removed from the power supply module(s) before accessing the chassis interior to install or remove system components (except for hot-swap components).



### 電源切断の警告

システムコンポーネントの取り付けまたは取り外しのために、シャーシ内部にアクセスするには、システムの電源はすべてのソースから切断され、電源コードは電源モジュールから取り外す必要があります。

### 警告

在你打开机箱并安装或移除内部器件前,必须将系统完全断电,并移除电源线。

### 警告

在您打開機殼安裝或移除內部元件前，必須將系統完全斷電，並移除電源線。

### Warnung

Das System muss von allen Quellen der Energie und vom Netzanschlusskabel getrennt sein, das von den Spg.Versorgungsteilmodulen entfernt wird, bevor es auf den Chassisinnenraum zurückgreift, um Systemsbestandteile anzubringen oder zu entfernen.

### ¡Advertencia!

El sistema debe ser disconnected de todas las fuentes de energía y del cable eléctrico quitado de los módulos de fuente de alimentación antes de tener acceso el interior del chasis para instalar o para quitar componentes de sistema.

### Attention

Le système doit être débranché de toutes les sources de puissance ainsi que de son cordon d'alimentation secteur avant d'accéder à l'intérieur du chasis pour installer ou enlever des composants de système.

אזהרה מפני ניתוק חשמלי

אזהרה!

יש לנתק את המערכת מכל מקורות החשמל ויש להסיר את כבל החשמלי מהספק לפני גישה לחלק הפנימי של המארז לצורך התקנת או הסרת רכיבים.

يجب فصل انظاؤ من جميع مصادر انطاقت وإزانت سهك انكهرباء من وحدة امداد انطاقت قيم

انصل إلى امناطق انداخييت نههيكم نشييج أو إزانت مكناث الجهاز

경고!

시스템에 부품들을 장착하거나 제거하기 위해서는 새시 내부에 접근하기 전에 반드시 전원 공급장치로부터 연결되어있는 모든 전원과 전기코드를 분리해주어야 합니다.

Waarschuwing

Voordat u toegang neemt tot het binnenwerk van de behuizing voor het installeren of verwijderen van systeem onderdelen, dient u alle spanningsbronnen en alle stroomkabels aangesloten op de voeding(en) van de behuizing te verwijderen

## Equipment Installation



**Warning!** Only authorized personnel and qualified service persons should be allowed to install, replace, or service this equipment.

機器の設置

トレーニングを受け認定された人だけがこの装置の設置、交換、またはサービスを許可されています。

警告

只有经过培训且具有资格的人员才能进行此设备的安装、更换和维修。

警告

只有經過受訓且具資格人員才可安裝、更換與維修此設備。

Warnung

Nur autorisiertes Personal und qualifizierte Servicetechniker dürfen dieses Gerät installieren, austauschen oder warten..

¡Advertencia!

Sólo el personal autorizado y el personal de servicio calificado deben poder instalar, reemplazar o dar servicio a este equipo.

**Attention**

Seul le personnel autorisé et le personnel de maintenance qualifié doivent être autorisés à installer, remplacer ou entretenir cet équipement..

אזהרה!

יש לאפשר רק צוות מורשה ואנשי שירות מוסמכים להתקין, להחליף או לטפל בציוד זה.

ينبغي السماح فقط للموظفين المعتمدين وأفراد الخدمة المؤهلين بتركيب هذا الجهاز أو استبداله أو صيانته.

**경고!**

승인된 직원과 자격을 갖춘 서비스 담당자만이 이 장비를 설치, 교체 또는 서비스할 수 있습니다.

**Waarschuwing**

Alleen geautoriseerd personeel en gekwalificeerd onderhoudspersoneel mag deze apparatuur installeren, vervangen of onderhouden..

**Restricted Area**

**Warning!** This unit is intended for installation in restricted access areas. A restricted access area can be accessed only through the use of a special tool, lock and key, or other means of security. (This warning does not apply to workstations).

**アクセス制限区域**

このユニットは、アクセス制限区域に設置されることを想定しています。

アクセス制限区域は、特別なツール、鍵と錠前、その他のセキュリティの手段を用いてのみ出入りが可能です。

**警告**

此部件应安装在限制进出的场所，限制进出的场所指只能通过使用特殊工具、锁和钥匙或其它安全手段进出的场所。

**警告**

此裝置僅限安裝於進出管制區域，進出管制區域係指僅能以特殊工具、鎖頭及鑰匙或其他安全方式才能進入的區域。

**Warnung**

Diese Einheit ist zur Installation in Bereichen mit beschränktem Zutritt vorgesehen. Der Zutritt zu derartigen Bereichen ist nur mit einem Spezialwerkzeug, Schloss und Schlüssel oder einer sonstigen Sicherheitsvorkehrung möglich.

**¡Advertencia!**

Esta unidad ha sido diseñada para instalación en áreas de acceso restringido. Sólo puede obtenerse acceso a una de estas áreas mediante la utilización de una herramienta especial, cerradura con llave u otro medio de seguridad.

**Attention**

Cet appareil doit être installée dans des zones d'accès réservés. L'accès à une zone d'accès réservé n'est possible qu'en utilisant un outil spécial, un mécanisme de verrouillage et une clé, ou tout autre moyen de sécurité.

אזור עם גישה מוגבלת

אזהרה!

יש להתקין את היחידה באזורים שיש בהם הגבלת גישה. הגישה ניתנת בעזרת 'כלי אבטחה בלבד' (מפתח, מנעול וכד.).

تخصيص هذه انحدة نترك بُها ف مناطق محظورة تم .  
ممكن انصلل إن منطقت محظورة فقط من خلال استخذاو أداة خاصت  
أو أ وس هُت أخري نلالأمما ققم ومفتاح

**경고!**

이 장치는 접근이 제한된 구역에 설치하도록 되어있습니다. 특수도구, 잠금 장치 및 키, 또는 기타 보안 수단을 통해서만 접근 제한 구역에 들어갈 수 있습니다.

**Waarschuwing**

Dit apparaat is bedoeld voor installatie in gebieden met een beperkte toegang. Toegang tot dergelijke gebieden kunnen alleen verkregen worden door gebruik te maken van speciaal gereedschap, slot en sleutel of andere veiligheidsmaatregelen.

## Battery Handling



**CAUTION:** There is risk of explosion if the battery is replaced by an incorrect type. Replace the battery only with the same or equivalent type recommended by the manufacturer. Dispose of used batteries according to the manufacturer's instructions

### 電池の取り扱い

バッテリーを間違ったタイプに交換すると爆発の危険があります。交換する電池はメーカーが推奨する型、または同等のものを使用下さい。使用済電池は製造元の指示に従って処分して下さい。

### 警告

如果更换的电池类型不正确，则存在爆炸危险。请只使用同类电池或制造商推荐的功能相当的电池更换原有电池。请按制造商的说明处理废旧电池。

### 警告

如果更換的電池類型不正確，則有爆炸危險。請使用製造商建議之相同或功能相當的電池更換原有電池。請按照製造商的說明指示處理廢棄舊電池。

### WARNUNG

Es besteht Explosionsgefahr, wenn die Batterie durch einen falschen Typ ersetzt wird. Ersetzen Sie die Batterie nur durch den gleichen oder vom Hersteller empfohlenen Batterietyp. Entsorgen Sie die benutzten Batterien nach den Anweisungen des Herstellers.

### ATTENTION

Il existe un risque d'explosion si la batterie est remplacée par un type incorrect. Ne la remplacer que par une pile de type semblable ou équivalent, recommandée par le fabricant. Jeter les piles usagées conformément aux instructions du fabricant.

### ADVERTENCIA

Existe riesgo de explosión si la batería se reemplaza por un tipo incorrecto. Reemplazar la batería exclusivamente con el mismo tipo o el equivalente recomendado por el fabricante. Desechar las baterías gastadas según las instrucciones del fabricante.

אזהרה!

קיימת סכנת פיצוץ אם הסוללה תוחלף בסוג שגוי. יש להחליף את הסוללה בסוג התואם מחברת יצרן מומלצת. סילוק הסוללות המשומשות יש לבצע לפי הוראות היצרן.

هناك خطر الانفجار إذا تم استبدال البطارية بنوع غير صحيح.  
 اسحبذال البطارية  
 فقط بنفس النوع أو ما يعادلها مما أوصت به الشركة المصنعة  
 جخلص من البطاريات المسحعملة وفقا لعمليات الشركة الصانعة

경고!

배터리를 잘못된 종류로 교체하면 폭발의 위험이 있습니다. 기존 배터리와 동일하거나 제조사에서 권장하는 동등한 종류의 배터리로만 교체해야 합니다. 제조사의 안내에 따라 사용된 배터리를 처리하여 주십시오.

#### WAARSCHUWING

Er bestaat explosiegevaar als de batterij wordt vervangen door een verkeerd type. Vervang de batterij slechts met hetzelfde of een equivalent type die door de fabrikant aanbevolen wordt. Gebruikte batterijen dienen overeenkomstig fabrieksvoorschriften afgevoerd te worden.

### Redundant Power Supplies



**Warning!** This unit might have more than one power supply connection. All connections must be removed to de-energize the unit.

冗長電源装置

このユニットは複数の電源装置が接続されている場合があります。

ユニットの電源を切るためには、すべての接続を取り外さなければなりません。

警告

此部件连接的电源可能不止一个，必须将所有电源断开才能停止给该部件供电。

警告

此装置连接的电源可能不只一个，必须切断所有电源才能停止对该装置的供电。

Warnung

Dieses Gerät kann mehr als eine Stromzufuhr haben. Um sicherzustellen, dass der Einheit kein Strom zugeführt wird, müssen alle Verbindungen entfernt werden.

## ¡Advertencia!

Puede que esta unidad tenga más de una conexión para fuentes de alimentación. Para cortar por completo el suministro de energía, deben desconectarse todas las conexiones.

## Attention

Cette unité peut avoir plus d'une connexion d'alimentation. Pour supprimer toute tension et tout courant électrique de l'unité, toutes les connexions d'alimentation doivent être débranchées.

אם קיים יותר מספק אחד

אזהרה!

ליחידה יש יותר מחיבור אחד של ספק. יש להסיר את כל החיבורים על מנת לרוקן את היחידה.

قد يكون لهذا الجهاز عدة اتصالات بوحدات امداد الطاقة .

يجب إزالة كافة الاتصالات لعسل الوحدة عن الكهرباء

## 경고!

이 장치에는 한 개 이상의 전원 공급 단자가 연결되어 있을 수 있습니다. 이 장치에 전원을 차단하기 위해서는 모든 연결 단자를 제거해야만 합니다.

## Waarschuwing

Deze eenheid kan meer dan één stroomtoevoeraansluiting bevatten. Alle aansluitingen dienen verwijderd te worden om het apparaat stroomloos te maken.

## Backplane Voltage



**Warning!** Hazardous voltage or energy is present on the backplane when the system is operating. Use caution when servicing.

バックプレーンの電圧

システムの稼働中は危険な電圧または電力が、バックプレーン上にかかっています。

修理する際には注意ください。

警告

当系统正在进行时，背板上有很危险的电压或能量，进行维修时务必小心。

警告

當系統正在進行時，背板上有危險的電壓或能量，進行維修時務必小心。

Warnung

Wenn das System in Betrieb ist, treten auf der Rückwandplatine gefährliche Spannungen oder Energien auf. Vorsicht bei der Wartung.

¡Advertencia!

Cuando el sistema está en funcionamiento, el voltaje del plano trasero es peligroso. Tenga cuidado cuando lo revise.

Attention

Lorsque le système est en fonctionnement, des tensions électriques circulent sur le fond de panier. Prendre des précautions lors de la maintenance.

מתח בפנל האחורי

אזהרה!

קיימת סכנת מתח בפנל האחורי בזמן תפעול המערכת. יש להיזהר במהלך העבודה.

هناك خطر من التيار الكهربائي أو الطاقة المتجددة على اللوحة  
عندما يكون النظام يعمل كه حذرا عند خدمة هذا الجهاز

경고!

시스템이 동작 중일 때 후면판 (Backplane)에는 위험한 전압이나 에너지가 발생 합니다.  
서비스 작업 시 주의하십시오.

Waarschuwing

Een gevaarlijke spanning of energie is aanwezig op de backplane wanneer het systeem in gebruik is. Voorzichtigheid is geboden tijdens het onderhoud.

## Comply with Local and National Electrical Codes



**Warning!** Installation of the equipment must comply with local and national electrical codes.

地方および国の電気規格に準拠

機器の取り付けはその地方および国の電気規格に準拠する必要があります。

警告

设备安装必须符合本地与本国电气法规。

警告

設備安裝必須符合本地與本國電氣法規。

Warnung

Die Installation der Geräte muss den Sicherheitsstandards entsprechen.

¡Advertencia!

La instalación del equipo debe cumplir con las normas de electricidad locales y nacionales.

Attention

L'équipement doit être installé conformément aux normes électriques nationales et locales.

תיאום חוקי החשמל הארצי  
אזהרה!  
התקנת הציוד חייבת להיות תואמת לחוקי החשמל המקומיים והארציים.

تركيب المعدات الكهربائية يجب أن يمتثل للقوايه المحلية والبطية المتعلقة  
بالكهرباء

경고!

현 지역 및 국가의 전기 규정에 따라 장비를 설치해야 합니다.

Waarschuwing

Bij installatie van de apparatuur moet worden voldaan aan de lokale en nationale elektriciteitsvoorschriften.

## Product Disposal



**Warning!** Ultimate disposal of this product should be handled according to all national laws and regulations.

製品の廃棄

この製品を廃棄処分する場合、国の関係する全ての法律・条例に従い処理する必要があります。

警告

本产品的废弃处理应根据所有国家的法律和规章进行。

警告

本產品的廢棄處理應根據所有國家的法律和規章進行。

Warnung

Die Entsorgung dieses Produkts sollte gemäß allen Bestimmungen und Gesetzen des Landes erfolgen.

¡Advertencia!

Al deshacerse por completo de este producto debe seguir todas las leyes y reglamentos nacionales.

## Attention

La mise au rebut ou le recyclage de ce produit sont généralement soumis à des lois et/ou directives de respect de l'environnement. Renseignez-vous auprès de l'organisme compétent.

סילוק המוצר

אזהרה!

סילוק סופי של מוצר זה חייב להיות בהתאם להנחיות וחוקי המדינה.

التخلص النهائي من هذا المنتج ينبغي التعامل معه وفقا لجميع القوانين واللوائح الوطنية عند

경고!

이 제품은 해당 국가의 관련 법규 및 규정에 따라 폐기되어야 합니다.

## Waarschuwing

De uiteindelijke verwijdering van dit product dient te geschieden in overeenstemming met alle nationale wetten en reglementen.

## Fan Warning



**Warning!** Hazardous moving parts. Keep away from moving fan blades. The fans might still be turning when you remove the fan assembly from the chassis. Keep fingers, screwdrivers, and other objects away from the openings in the fan assembly's housing.

ファンの警告

警告!回転部品に注意。運転中は回転部(羽根)に触れないでください。シャーシから冷却ファン装置を取り外した際、ファンがまだ回転している可能性があります。ファンの開口部に、指、ドライバー、およびその他のものを近づけないで下さい。

警告!

警告! 危險的可移動性零件。請務必與轉動的风扇叶片保持距離。當您從機架移除風扇裝置，風扇可能仍在轉動。小心不要將手指、螺絲起子和其他物品太靠近風扇

警告

危險的可移動性零件。請務必與轉動的风扇叶片保持距離。當您從機架移除風扇裝置，風扇可能仍在轉動。小心不要將手指、螺絲起子和其他物品太靠近風扇。

**Warnung**

Gefährlich Bewegende Teile. Von den bewegenden Lüfterblätter fern halten. Die Lüfter drehen sich u. U. noch, wenn die Lüfterbaugruppe aus dem Chassis genommen wird. Halten Sie Finger, Schraubendreher und andere Gegenstände von den Öffnungen des Lüftergehäuses entfernt.

**¡Advertencia!**

Riesgo de piezas móviles. Mantener alejado de las aspas del ventilador. Los ventiladores podran dar vuelta cuando usted quite el montaje del ventilador del chasis. Mantenga los dedos, los destornilladores y todos los objetos lejos de las aberturas del ventilador

**Attention**

Pieces mobiles dangereuses. Se tenir a l'écart des lames du ventilateur Il est possible que les ventilateurs soient toujours en rotation lorsque vous retirerez le bloc ventilateur du châssis. Prenez garde à ce que doigts, tournevis et autres objets soient éloignés du logement du bloc ventilateur.

**אזהרה!**

חלקים נעים מסוכנים. התרחק מלהבי המאוורר בפעולה כאשר מסירים את חלקי המאוורר מהמארז, יתכן והמאווררים עדיין עובדים. יש להרחיק למרחק בטוח את האצבעות וכלי עבודה שונים מהפתחים בתוך המאוורר

تحذير! أجزاء متحركة خطيرة. ابتعد عن شفرات المروحة المتحركة. من الممكن أن المراوح لا تزال تدور عند إزالة كتلة المروحة من الهيكل يجب إبقاء الأصابع ومفكات البراغي وغيرها من الأشياء بعيدا عن الفتحات في كتلة المروحة.

**경고!**

움직이는 위험한 부품. 회전하는 송풍 날개에 접근하지 마세요. 새시로부터 팬 조립품을 제거할 때 팬은 여전히 회전하고 있을 수 있습니다. 팬 조립품 외관의 열려있는 부분들로부터 손가락 및 스크류드라이버, 다른 물체들이 가까이 하지 않도록 배치해 주십시오.

**Waarschuwing**

Gevaarlijk bewegende onderdelen. Houd voldoende afstand tot de bewegende ventilatorbladen. Het is mogelijk dat de ventilator nog draait tijdens het verwijderen van het ventilatorsamenstel uit het chassis. Houd uw vingers, schroevendraaiers en eventuele andere voorwerpen uit de buurt van de openingen in de ventilatorbehuizing.

## Power Cable and AC Adapter



**Warning!** When installing the product, use the provided or designated connection cables, power cables and AC adaptors. Using any other cables and adaptors could cause a malfunction or a fire. Electrical Appliance and Material Safety Law prohibits the use of UL or CSA -certified cables (that have UL/CSA shown on the cord) for any other electrical devices than products designated by Supermicro only.

### 電源コードとACアダプター

製品を設置する場合、提供または指定および購入された接続ケーブル、電源コードとACアダプターを該当する地域の条例や安全基準に適合するコードサイズやプラグと共に使用下さい。他のケーブルやアダプタを使用すると故障や火災の原因になることがあります。

電気用品安全法は、ULまたはCSA認定のケーブル(UL/CSAマークがコードに表記)を Supermicro が指定する製品以外に使用することを禁止しています。

### 警告

安装此产品时,请使用本身提供的或指定的或采购的连接线,电源线和电源适配器。包含遵照当地法规和安全要求的合规的电源线尺寸和插头。使用其它线材或适配器可能会引起故障或火灾。除了Supermicro所指定的产品,电气用品和材料安全法律规定禁止使用未经UL或CSA认证的线材。(线材上会显示UL/CSA符号)。

### 警告

安裝此產品時,請使用本身提供的或指定的或採購的連接線,電源線和電源適配器。包含遵照當地法規和安全要求的合規的電源線尺寸和插頭。使用其它線材或適配器可能會引起故障或火災。除了Supermicro所指定的產品,電氣用品和材料安全法律規定禁止使用未經UL或CSA認證的線材。(線材上會顯示UL/CSA符號)。

### Warnung

Nutzen Sie beim Installieren des Produkts ausschließlich die von uns zur Verfügung gestellten Verbindungskabeln, Stromkabeln und/oder Adapter, die Ihre örtlichen Sicherheitsstandards einhalten. Der Gebrauch von anderen Kabeln und Adapter können Fehlfunktionen oder Feuer verursachen. Die Richtlinien untersagen das Nutzen von UL oder CAS zertifizierten Kabeln (mit UL/CSA gekennzeichnet), an Geräten oder Produkten die nicht mit Supermicro gekennzeichnet sind.

## ¡Advertencia!

Cuando instale el producto, utilice la conexión provista o designada o procure cables, Cables de alimentación y adaptadores de CA que cumplan con los códigos locales y los requisitos de seguridad, incluyendo el tamaño adecuado del cable y el enchufe. El uso de otros cables y adaptadores podría causar un mal funcionamiento o un incendio. La Ley de Seguridad de Aparatos Eléctricos y de Materiales prohíbe El uso de cables certificados por UL o CSA (que tienen el certificado UL / CSA en el código) para cualquier otros dispositivos eléctricos que los productos designados únicamente por Supermicro.

## Attention

Lors de l'installation du produit, utilisez les cables de connection fournis ou désigné ou achetez des cables, cables de puissance et adaptateurs respectant les normes locales et les conditions de securite y compris les tailles de cables et les prises electriques appropries. L'utilisation d'autres cables et adaptateurs peut provoquer un dysfonctionnement ou un incendie. Appareils électroménagers et la Loi sur la Sécurité Matériel interdit l'utilisation de câbles certifiés- UL ou CSA (qui ont UL ou CSA indiqué sur le code) pour tous les autres appareils électriques sauf les produits désignés par Supermicro seulement.

AC ימאתמו מיימשח מילבכ

!הרהזא

ךרוצל ומאתוה וא ושכרנ רשא AC מיימאתמו מיקפס, מילבכב שמתשהל שי, רצומה תא מיניקתמ רשאכ לכב שומיש . עקתהו לבכה לש הנוכח הדימ ללוכ, תוימוקמה תוחיטבה תושירדל ומאתוה רשאו, הנקתהה למשחה ירישכמב שומישה יקוחל מאתהב. ילמשח רצק וא הלקתל מורגל לולע, רחא גוסמ מאתמ וא לבכ לש דוק מהילע עיפומ רשאכ) UL-ב או CSA-ב -ב מיכמומה מילבכב שמתשהל רוסיא מייק, תוחיטבה יקוחו דבלב Supermicro י"ע מאתוה רשא רצומב קר אלא, רחא ילמשח רצומ לכ רובע (UL/CSA)

תאלבאלא אארשב מץ וא אדדחמלא וא ארפוטמלא תאליטוטלא מאדחטסאב מץ, אגתנמלא בייקרת דנע לכלז יפ אמב אילחמלא אמאלסלא תאבלטתמו נינאווקב מאזתלאלא אמ דדרתמלא ראיטלא תאלוחמו אילברמלא קיירח וא לטע יפ בבסטטי דץ ירשא תאלוחמו תאלבאלא יא מאדחטסא. מילסלא סבאלאו ולסומלא מץ ח CSA וא UL לבק נמ אדמתמלא תאלבאלא מאדחטסא תאדעמלא אילברמלא אזהאלל אמאלסלא נונאק רזחי Supermicro לבק נמ אדדחמלא אילחמלא תאגתנמלא רייג ירשא תאדעמ יא אמ (UL/CSA) אמאלע למחתיטלאו

### 전원 케이블 및 AC 어댑터

경고! 제품을 설치할 때 현지 코드 및 적절한 굵기의 코드와 플러그를 포함한 안전 요구 사항을 준수하여 제공되거나 지정된 연결 혹은 구매 케이블, 전원 케이블 및 AC 어댑터를 사용하십시오.

다른 케이블이나 어댑터를 사용하면 오작동이나 화재가 발생할 수 있습니다. 전기 용품 안전법은 UL 또는 CSA 인증 케이블 (코드에 UL / CSA가 표시된 케이블)을 Supermicro가 지정한 제품 이외의 전기 장치에 사용하는 것을 금지합니다.

### Stroomkabel en AC-Adapter

Waarschuwing! Bij het aansluiten van het Product uitsluitend gebruik maken van de geleverde Kabels of een andere geschikte aan te schaffen Aansluitmethode, deze moet altijd voldoen aan de lokale voorschriften en veiligheidsnormen, inclusief de juiste kabeldikte en stekker. Het gebruik van niet geschikte Kabels en/of Adapters kan een storing of brand veroorzaken. Wetgeving voor Elektrische apparatuur en Materiaalveiligheid verbied het gebruik van UL of CSA -gecertificeerde Kabels (met UL/CSA in de code) voor elke andere toepassing dan de door Supermicro hiervoor beoogde Producten.

# Appendix B

## System Specifications

### Processors

Supports an AmpereOne® processor with up to 192 cores and a TDP of up to 400 W in an LGA5964 socket

### BIOS

256 Mb SPI Flash BIOS

APCI, SPI dual/quad speed support, Plug and Play (PnP), Real Time Clock (RTC) Wakeup

### Memory

Supports up to 8 TB of DDR5-5600 ECC RDIMM/3DS RDIMM with speeds of up to 5200 MT/s in 16 memory slots (1R2DPC)

### Storage Drives

Six front hot-swap 2.5" NVMe drive bays

One M.2 NVMe slot (M-key 22110)

### PCI Expansion Slots

Two PCIe 5.0 x8 slots: one FHFL, one FHHL

Two PCIe 5.0 x16 slots: one FHFL, one FHHL

One PCIe 5.0 x16 LP slot

One PCIe 5.0 x16 AIOM slot (OCP 3.0 compatible)

### Input/Output

USB:

Two front USB 3.0 ports

COM:

One COM port (serial)

Video:

One VGA port

LAN:

One RJ45 Dedicated IPMI LAN port

Two 25 Gb SFP28 Ethernet ports

### Motherboard

R13SPD; 13" (W) x 12" (L) (330.2 mm x 304.8 mm)

### Chassis

CSE-LB23MTS-R000NDP, 2U Rackmount, 3.5" x 17.2" x 17" (88.9 x 436.88 x 431.8 mm) (H x W x D)

### System Cooling

Four 8-cm heavy-duty fans

### Power Supply

Model: PWS-1K62A-1R, 1600 W redundant modules, 80Plus Titanium level

AC Input

1000 W: 100-127 Vac

1000 W: 100-127 Vac / 50-60 Hz

1600 W: 200-240 Vac

1600 W: 200-240 Vac / 50-60 Hz

+12V

Max: 83 A / Min: 0 A (100 Vac-127 Vac)

Max: 133 A / Min: 0 A (200 Vac-240 Vac)

12V SB

Max: 2.1 A / Min: 0 A

**Operating Environment**

Operating Temperature: 10°C to 35°C (50°F to 95°F)

Non-operating Temperature: -40°C to 60°C (-40°F to 140° F)

Operating Relative Humidity: 8% to 90% (non-condensing)

Non-operating Relative Humidity: 5% to 95% (non-condensing)

**Regulatory Compliance**

FCC, ICES, CE, UKCA, VCCI, RCM, NRTL, CB

**Applied Directives, Standards**

EMC/EMI: 2014/30/EU (EMC Directive) CLASS A

Electromagnetic Compatibility Regulations 2016

FCC Part 15 Subpart B

ICES-003

VCCI-CISPR 32

AS/NZS CISPR 32

BS/EN 55032

BS/EN 55035

CISPR 32

CISPR 35

BS/EN 61000-3-2

BS/EN 61000-3-3

BS/EN 61000-4-2

BS/EN 61000-4-3

BS/EN 61000-4-4

BS/EN 61000-4-5

BS/EN 61000-4-6

BS/EN 61000-4-8

BS/EN 61000-4-11

Product Safety: 2014/35/EU (LVD Directive)

UL/CSA 62368-1 (USA and Canada)

Electrical Equipment (Safety) Regulations 2016

IEC/BS/EN 62368-1

Environment:

2011/65/EU (RoHS Directive)

EC 1907/2006 (REACH)

2012/19/EU (WEEE Directive)

California Proposition 65

**Warning!** This product can expose you to chemicals including lead, known to the State of California to cause cancer and birth defects or other reproductive harm. For more information, go to [www.P65Warnings.ca.gov](http://www.P65Warnings.ca.gov).

**Perchlorate Warning**

California Best Management Practices Regulations for Perchlorate Materials: This Perchlorate warning applies only to products containing CR (Manganese Dioxide) Lithium coin cells. "Perchlorate Material-special handling may apply. See [www.dtsc.ca.gov/hazardouswaste/perchlorate](http://www.dtsc.ca.gov/hazardouswaste/perchlorate)"

この装置は、クラスA機器です。この装置を住宅環境で使用すると電波妨害を引き起こすことがあります。この場合には使用者が適切な対策を講ずるよう要求されることがあります。

VCCI – A

# Appendix C

## BIOS Codes

### C.1 BIOS Error POST (Beep) Codes

During the Power-On Self-Test (POST) routines, which are performed each time the system is powered on, errors may occur.

Non-fatal errors are those which, in most cases, allow the system to continue the boot-up process. The error messages normally appear on the screen.

**Fatal errors** are those which will not allow the system to continue the boot-up procedure. If a fatal error occurs, you should consult with your system manufacturer for possible repairs.

These fatal errors are usually communicated through a series of audible beeps. The table shown below lists some common errors and their corresponding beep codes encountered by users.

BIOS Beep (POST) Codes		
Beep Code	Error Message	Description
1 beep	Refresh	Circuits have been reset (Ready to power up)
5 short, 1 long	Memory error	No memory detected in system
5 long, 2 short	Display memory read/write error	Video adapter missing or with faulty memory
1 long continuous	System OH	System overheat condition

### C.2 Additional BIOS POST Codes

The AMI BIOS supplies additional checkpoint codes, which are documented online at <https://www.supermicro.com/support/manuals/> ("AMI BIOS POST Codes User's Guide").

For information on AMI updates, refer to <http://www.ami.com/products/>.

## Appendix D

### Updating BIOS and BMC with OpenBMC WebGUI

**Important:** Do not upgrade firmware unless your system has a firmware-related issue. Flashing the wrong firmware can cause irreparable damage to the system. In no event shall Supermicro be liable for direct, indirect, special, incidental, or consequential damages arising from a firmware update. If you need to update firmware, do not shut down or reset the system while firmware is updating.

#### D.1 Overview

The OpenBMC WebGUI provides a function to update the BIOS and BMC firmware on the motherboard. Visit our website at [www.supermicro.com](http://www.supermicro.com) to download the BIOS or BMC update packages. Extract the firmware image files from the firmware update packages onto the system you will use to access the OpenBMC Web GUI. The OpenBMC Web GUI can be accessed by entering the R13SPD motherboard BMC IP address into a web browser while on the same network as the motherboard.

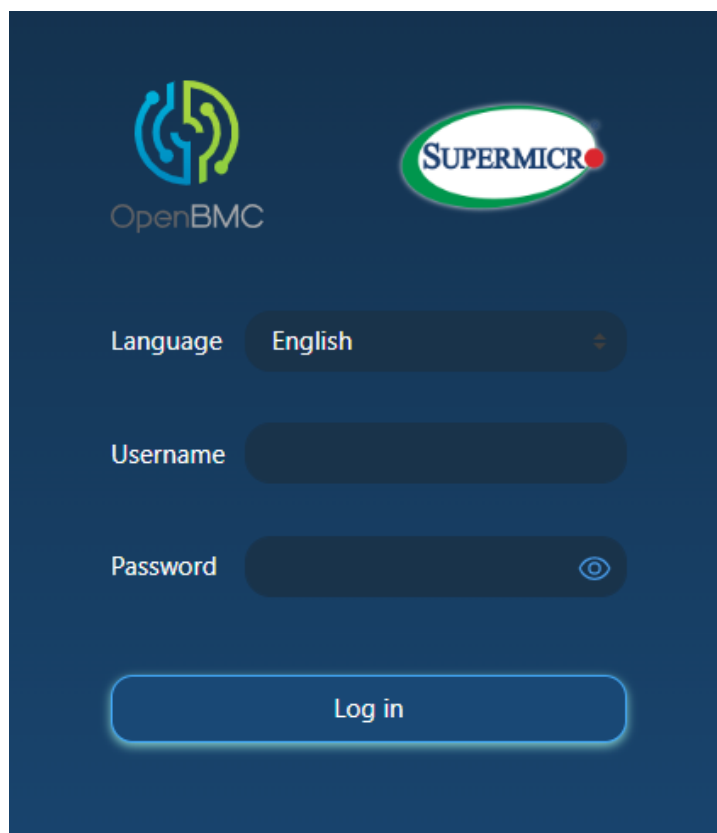

## D.2 Updating BIOS with OpenBMC WebGUI

1. From the OpenBMC Web GUI sidebar menu, enter the Operations submenu, click on Firmware, and then select BIOS.

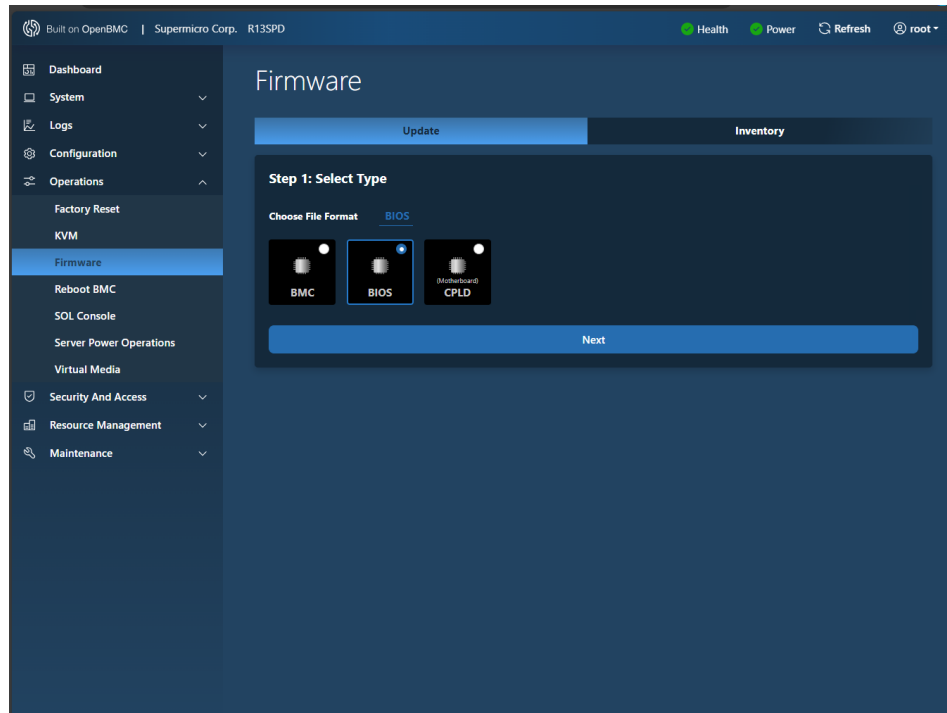

2. Click Next.

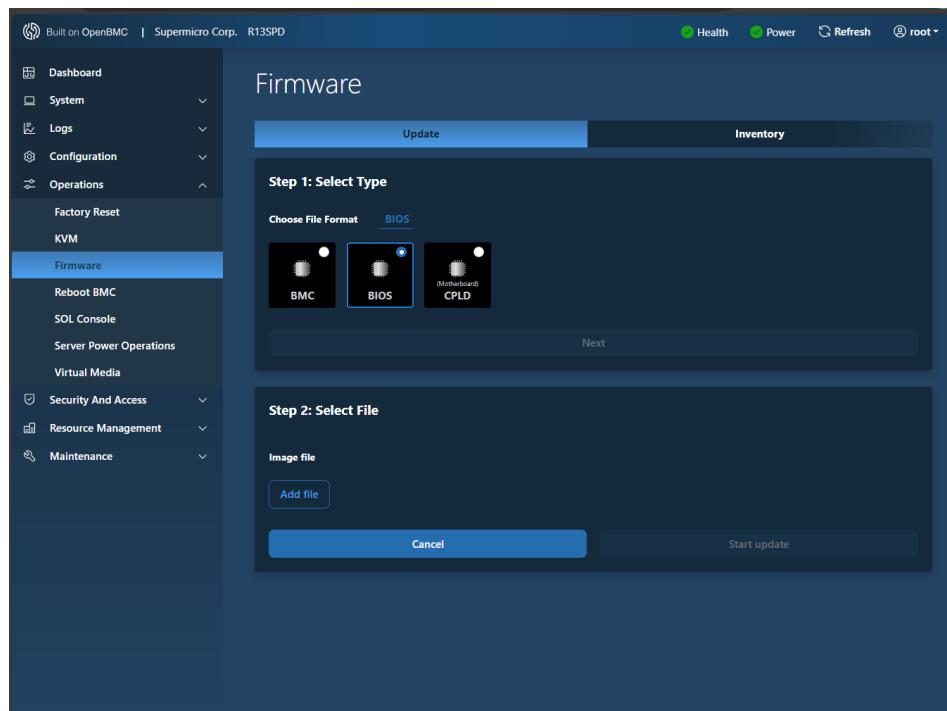

3. Click "Add File" and navigate to the BIOS image file in .tar format.

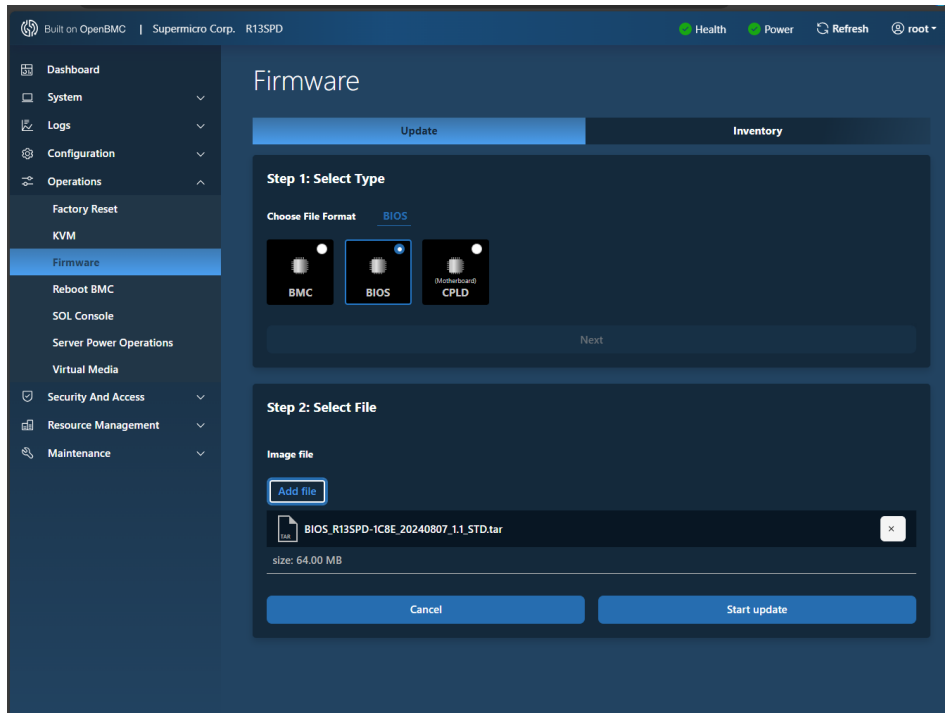

4. Click "Start Update" after selecting the BIOS image file in .tar format. Ensure that the motherboard can be safely rebooted.

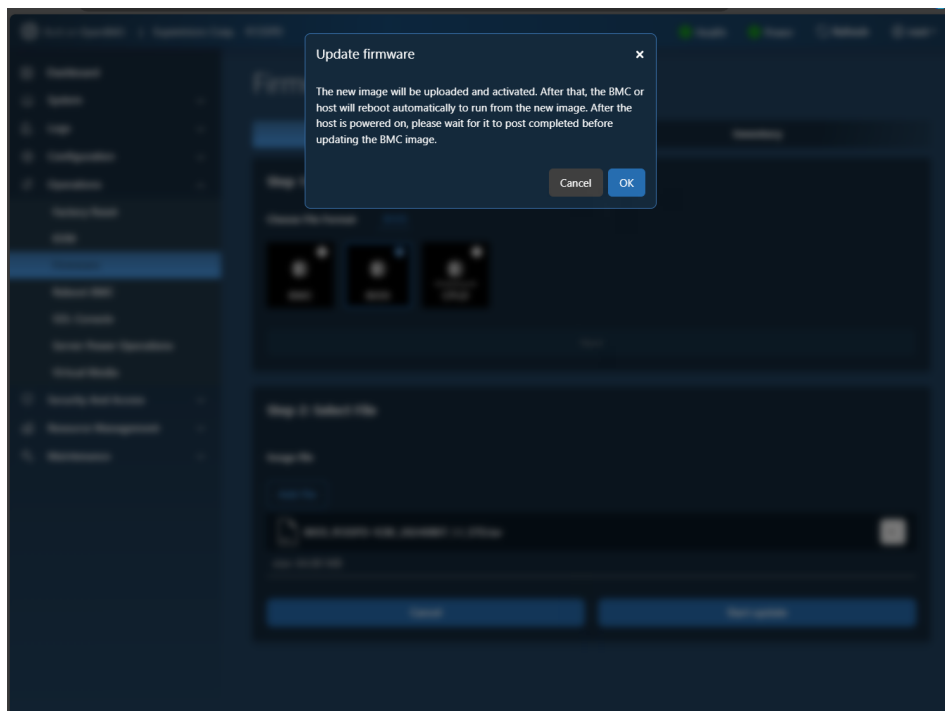

- Click OK to initiate the BIOS firmware update. Do not interrupt the BIOS update process. The BIOS update process may require several minutes. The BIOS update process will be indicated in the upper right corner.

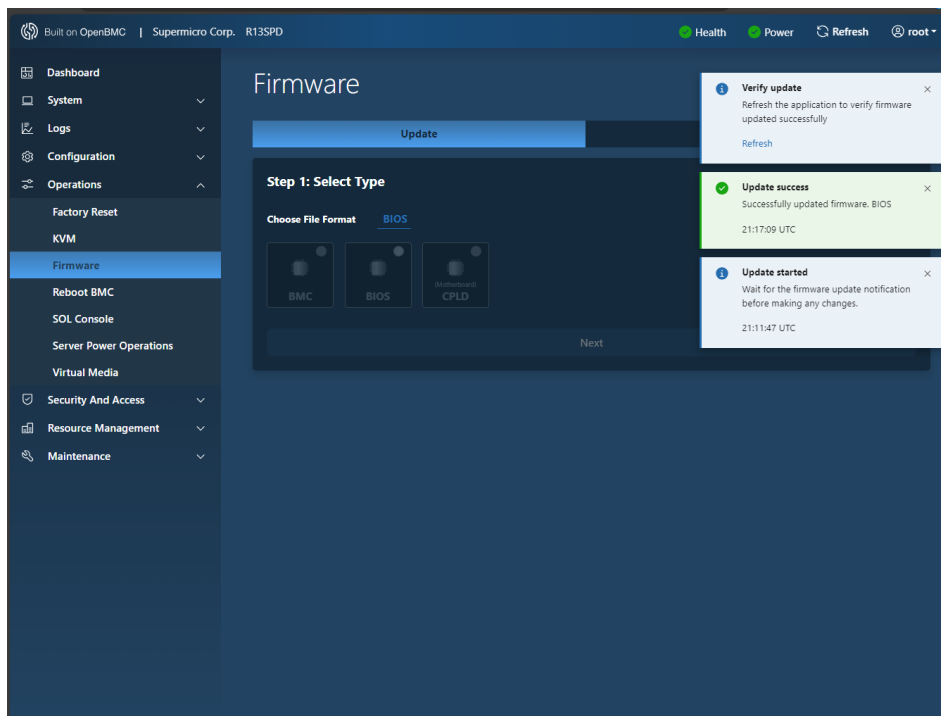

- After "Verify update" appears, use the KVM feature in the Operations submenu to enter the UEFI BIOS setup. Ensure the BIOS version and build date in the UEFI BIOS setup match the new BIOS version and build date.

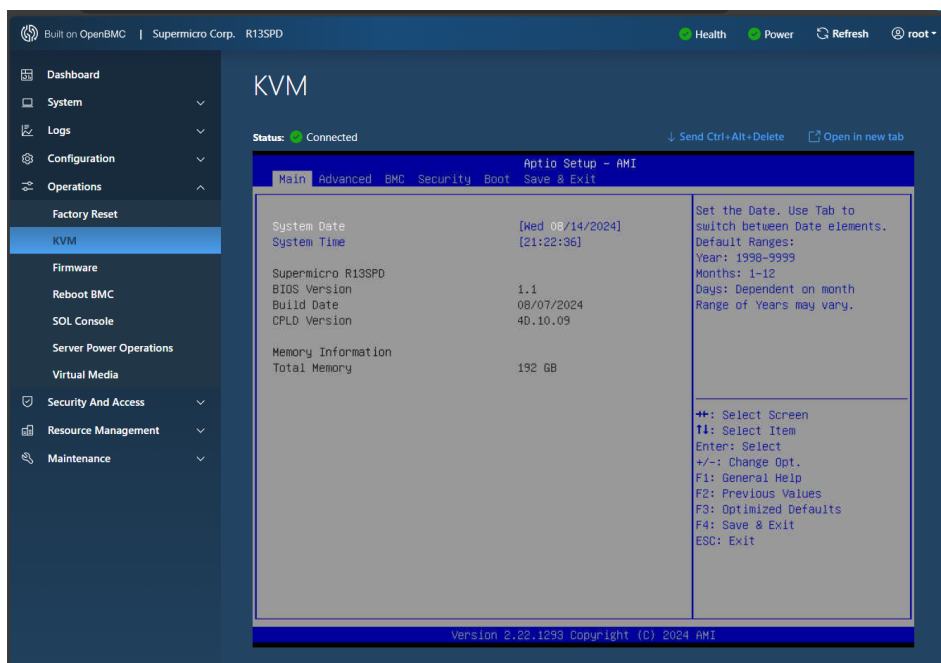

## D.3 Updating BMC with OpenBMC WebGUI

1. From the OpenBMC Web GUI sidebar menu, enter the Operations submenu, click on Firmware, and then select BMC.

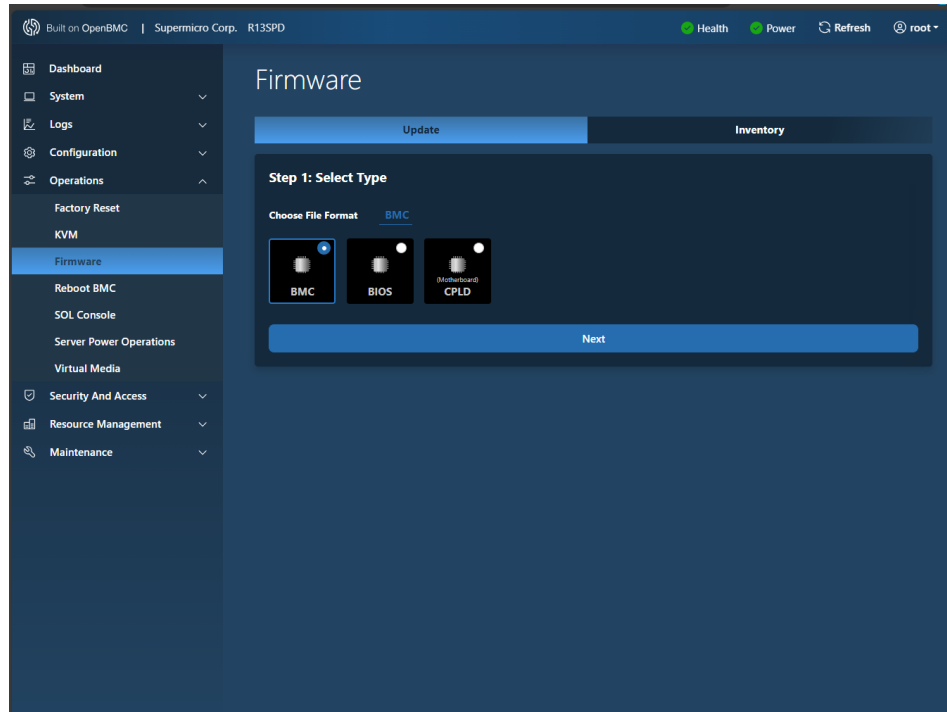

2. Click Next.

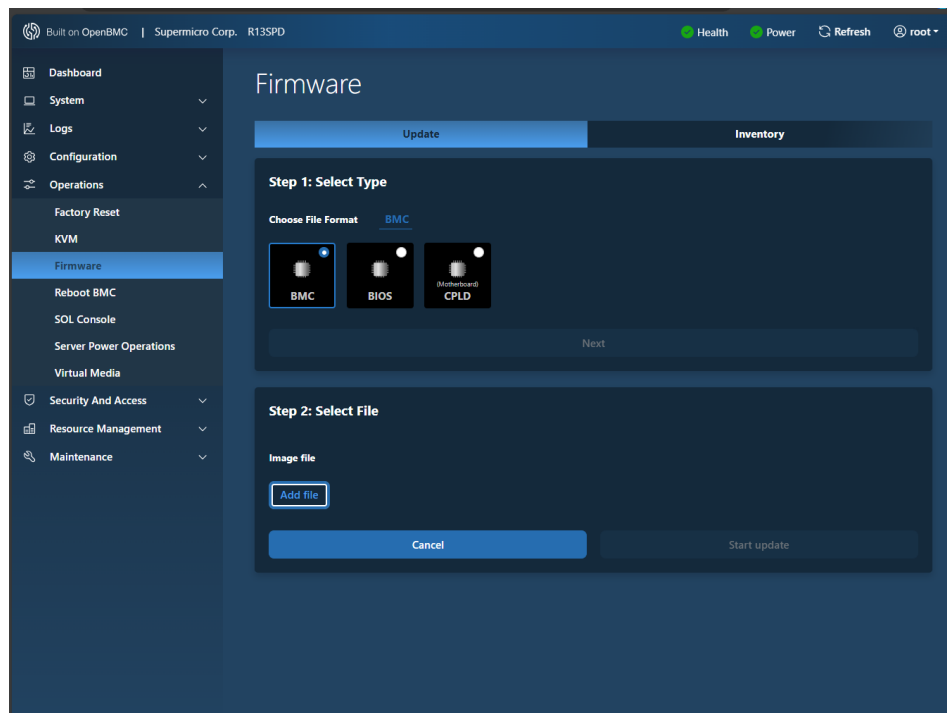

- Click "Add File" and navigate to the BMC image file in .tar format.

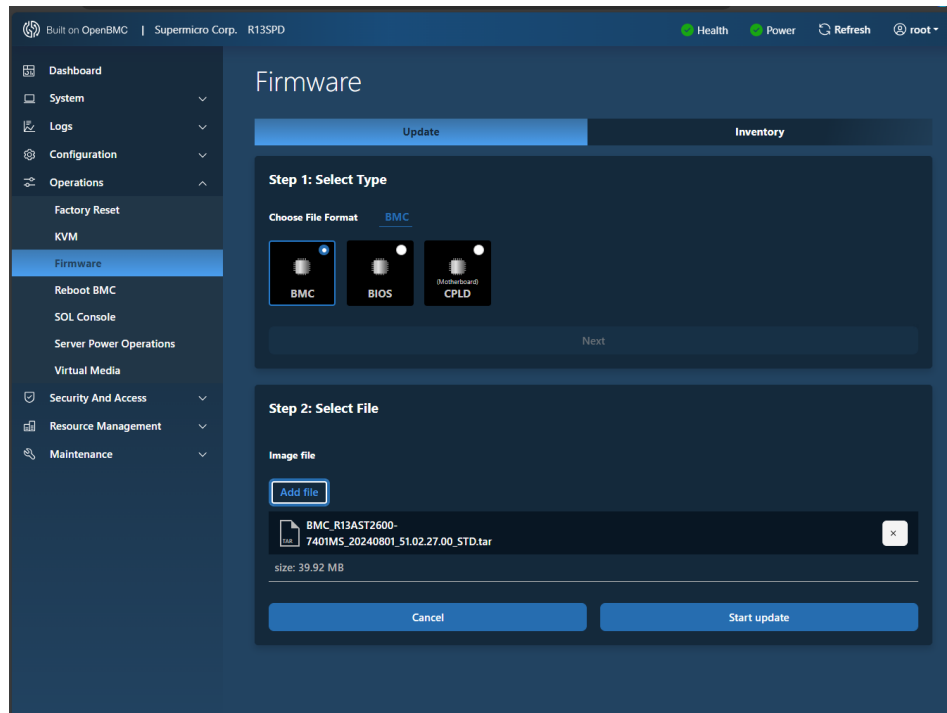

- Click "Start update" after selecting the BMC image file in .tar format. Ensure that the motherboard can be safely rebooted.

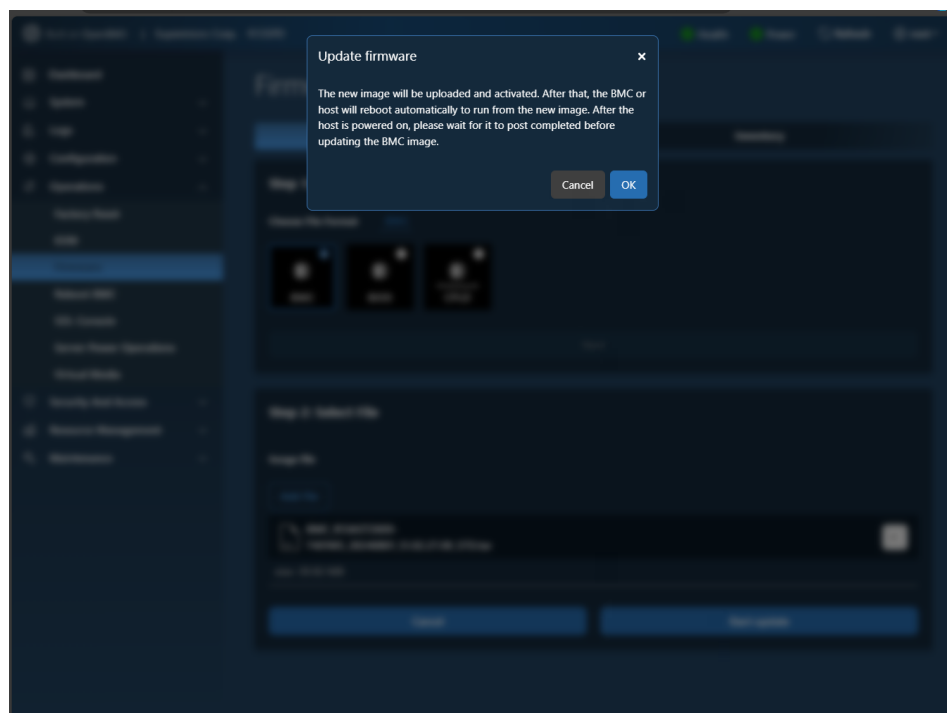

- Click OK to initiate the BMC firmware update. Do not interrupt the BMC update process, as it may take several minutes to complete. The status of the BMC update will be indicated in the upper right corner.

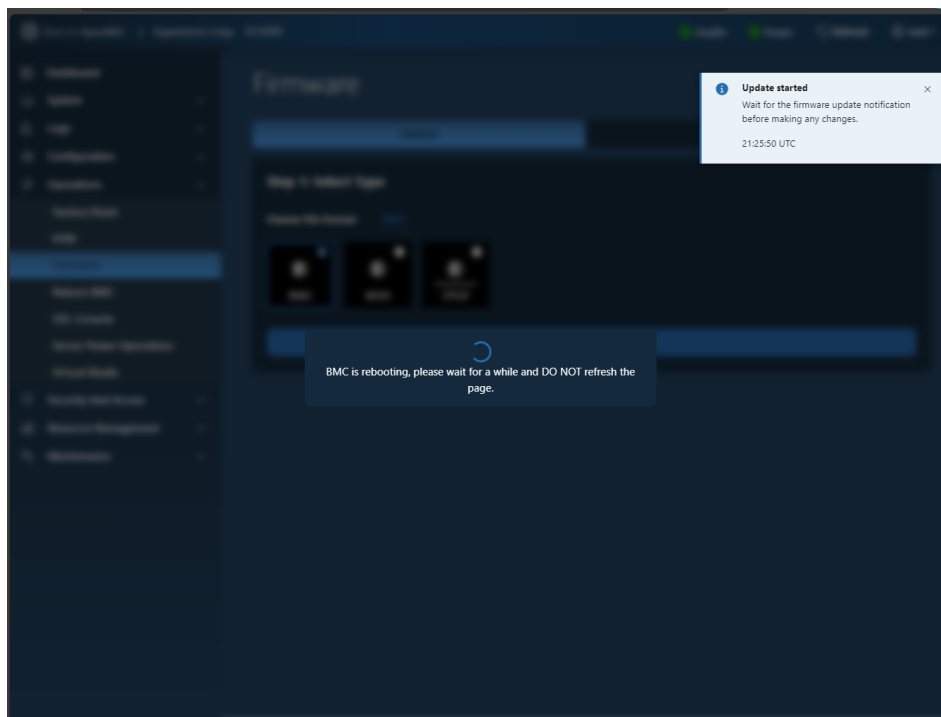

- Once "Verify Update" appears, use the KVM feature from the Operations submenu to enter the UEFI BIOS setup. Ensure the BMC revision in the UEFI BIOS setup matches the new BMC revision.

