



SuperServer[®] SYS-221GE-TNHT-LC1



USER'S MANUAL

Revision 1.0

The information in this User's Manual has been carefully reviewed and is believed to be accurate. The vendor assumes no responsibility for any inaccuracies that may be contained in this document, and makes no commitment to update or to keep current the information in this manual, or to notify any person or organization of the updates. Please Note: For the most up-to-date version of this manual, please see our website at www.supermicro.com.

Super Micro Computer, Inc. ("Supermicro") reserves the right to make changes to the product described in this manual at any time and without notice. This product, including software and documentation, is the property of Supermicro and/or its licensors, and is supplied only under a license. Any use or reproduction of this product is not allowed, except as expressly permitted by the terms of said license.

IN NO EVENT WILL Super Micro Computer, Inc. BE LIABLE FOR DIRECT, INDIRECT, SPECIAL, INCIDENTAL, SPECULATIVE OR CONSEQUENTIAL DAMAGES ARISING FROM THE USE OR INABILITY TO USE THIS PRODUCT OR DOCUMENTATION, EVEN IF ADVISED OF THE POSSIBILITY OF SUCH DAMAGES. IN PARTICULAR, SUPER MICRO COMPUTER, INC. SHALL NOT HAVE LIABILITY FOR ANY HARDWARE, SOFTWARE, OR DATA STORED OR USED WITH THE PRODUCT, INCLUDING THE COSTS OF REPAIRING, REPLACING, INTEGRATING, INSTALLING OR RECOVERING SUCH HARDWARE, SOFTWARE, OR DATA.

Any disputes arising between manufacturer and customer shall be governed by the laws of Santa Clara County in the State of California, USA. The State of California, County of Santa Clara shall be the exclusive venue for the resolution of any such disputes. Supermicro's total liability for all claims will not exceed the price paid for the hardware product.

FCC Statement: This equipment has been tested and found to comply with the limits for a Class A or Class B digital device pursuant to Part 15 of the FCC Rules. These limits are designed to provide reasonable protection against harmful interference when the equipment is operated in industrial environment for Class A device or in residential environment for Class B device. This equipment generates, uses, and can radiate radio frequency energy and, if not installed and used in accordance with the manufacturer's instruction manual, may cause harmful interference with radio communications. Operation of this equipment in a residential area is likely to cause harmful interference, in which case you will be required to correct the interference at your own expense.

California Best Management Practices Regulations for Perchlorate Materials: This Perchlorate warning applies only to products containing CR (Manganese Dioxide) Lithium coin cells. "Perchlorate Material-special handling may apply. See www.dtsc.ca.gov/hazardouswaste/perchlorate".



WARNING: This product can expose you to chemicals including lead, known to the State of California to cause cancer and birth defects or other reproductive harm. For more information, go to www.P65Warnings.ca.gov.

The products sold by Supermicro are not intended for and will not be used in life support systems, medical equipment, nuclear facilities or systems, aircraft, aircraft devices, aircraft/emergency communication devices or other critical systems whose failure to perform be reasonably expected to result in significant injury or loss of life or catastrophic property damage. Accordingly, Supermicro disclaims any and all liability, and should buyer use or sell such products for use in such ultra-hazardous applications, it does so entirely at its own risk. Furthermore, buyer agrees to fully indemnify, defend and hold Supermicro harmless for and against any and all claims, demands, actions, litigation, and proceedings of any kind arising out of or related to such ultra-hazardous use or sale.

Manual Revision 1.0

Release Date: April 30, 2025

Unless you request and receive written permission from Super Micro Computer, Inc., you may not copy any part of this document. Information in this document is subject to change without notice. Other products and companies referred to herein are trademarks or registered trademarks of their respective companies or mark holders.

Copyright © 2025 by Super Micro Computer, Inc.
All rights reserved.

Printed in the United States of America

Preface

About this Manual

This manual is written for professional system integrators and PC technicians. It provides information for the installation and use of the server. Installation and maintenance should be performed by certified service technicians only.

Please refer to the SYS-221GE-TNHT-LC1 server specifications page on our website for updates on supported memory, processors and operating systems (<http://www.supermicro.com>).

Notes

For your system to work properly, please follow the links below to download all necessary drivers/utilities and the user's manual for your server.

- Supermicro product manuals: <http://www.supermicro.com/support/manuals/>
- Product drivers and utilities: <https://www.supermicro.com/wdl>
- Product safety info: http://www.supermicro.com/about/policies/safety_information.cfm

If you have any questions, please contact our support team at:
support@supermicro.com

This manual may be periodically updated without notice. Please check the Supermicro website for possible updates to the manual revision level.

Secure Data Deletion

A secure data deletion tool designed to fully erase all data from storage devices can be found on our website: https://www.supermicro.com/about/policies/disclaimer.cfm?url=/wdl/utility/Lot9_Secure_Data_Deletion_Utility/

Warnings

Special attention should be given to the following symbols used in this manual.



Warning! Indicates important information given to prevent equipment/property damage or personal injury.



Warning! Indicates high voltage may be encountered when performing a procedure.

Contents

Chapter 1 Introduction

1.1 Overview.....	9
1.2 System Features	10
Front View	10
Control Panel.....	11
Rear View.....	12
Top View.....	13
1.3 System Architecture	15
Printed Circuit Board Locations	15
Data Plane Block Diagram	16
1.4 Motherboard Layout	20
Quick Reference Table.....	21
Motherboard Block Diagram	23
1.5 Where to Get Replacement Components	24
1.6 Returning Merchandise for Service.....	24

Chapter 2 Server Installation

2.1 Overview.....	25
2.2 Unpacking the System	25
2.3 Preparing for Setup	25
Choosing a Setup Location.....	25
Rack Precautions	26
Server Precautions.....	26
Rack Mounting Considerations	26
Ambient Operating Temperature.....	27
Airflow	27
Mechanical Loading.....	27
Circuit Overloading	27
Reliable Ground.....	27
2.4 Installing the Rails	28
Identifying Sections of the the Rails	28
Adjusting the Rail Length	28
Installing the Outer Rails onto the Rack.....	29

2.5	Installing the Chassis into a Rack	30
2.6	Removing the Chassis into a Rack.....	31
2.7	Connecting to a Coolant Distribution Unit (CDU)	32
Chapter 3 Maintenance and Component Installation		
3.1	Removing Power	33
3.2	Accessing the System.....	34
3.3	Static-Sensitive Devices.....	35
	Precautions	35
3.4	Memory Support and Installation	36
	Memory Support.....	36
	DDR5 Memory Support for the 4th Gen. Intel Xeon Scalable Processors.....	36
	DDR5 Memory Support for the 5th Gen. Intel Xeon Scalable Processors.....	36
	Memory Population for the X13DEG-R Motherboard (with 32 DIMM Slots).....	37
	DIMM Installation	40
	DIMM Removal	41
3.5	Motherboard Battery.....	42
	Battery Removal.....	42
	Proper Battery Disposal	42
	Battery Installation.....	42
3.6	M.2 SSDs	43
3.7	Storage Drives.....	44
	Drive Carriers	44
	Removing Drive Carriers.....	45
	Installing 2.5" SSDs	46
3.8	Expansion Cards	47
	Riser Cards	47
	Installing Expansion Cards	48
3.9	Graphics Processing Units.....	49
3.10	System Cooling	52
	System Fans	52
	Air Shroud	54
	Checking the Server Air Flow.....	55
	Overheating	55
3.11	Power Supply	56

Chapter 4 Motherboard Connections

4.1 Power Connections	58
4.2 Headers and Connectors	59
Front Control Panel.....	62
4.3 Jumpers.....	65
Explanation of Jumpers	65
4.4 Motherboard LED Indicators	66

Chapter 5 Software

5.1 Microsoft Windows OS Installation.....	68
5.2 Driver Installation.....	70
5.3 BMC.....	71
BMC ADMIN User Password	71

Chapter 6 Optional Components

6.1 Optional Parts List.....	72
------------------------------	----

Chapter 7 Troubleshooting and Support

7.1 Information Resources	73
Website	73
Direct Links for the SYS-221GE-TNHT-LC1 System	73
Direct Links for General Support and Information	73
7.2 Baseboard Management Controller (BMC).....	74
7.3 Troubleshooting Procedures	75
General Technique	75
No Power	75
No Video	76
System Boot Failure	76
Memory Errors	76
Losing the System Setup Configuration	76
If the System Becomes Unstable.....	76
7.4 Crash Dump Using BMC.....	78
7.5 UEFI BIOS Recovery	79
Overview	79
Recovering the UEFI BIOS Image.....	79
Recovering the Main BIOS Block with a USB Device.....	79
7.6 CMOS Clear	84

7.7 Where to Get Replacement Components85

7.8 Reporting an Issue85

 Technical Support Procedures85

 Returning Merchandise for Service.....85

 Vendor Support Filing System86

7.9 Feedback.....86

Appendix A Standardized Warning Statements for AC Systems

Appendix B System Specifications

Contacting Supermicro

Headquarters

Address: Super Micro Computer, Inc.
980 Rock Ave.
San Jose, CA 95131 U.S.A.

Tel: +1 (408) 503-8000

Fax: +1 (408) 503-8008

Email: marketing@supermicro.com (General Information)
Sales-USA@supermicro.com (Sales Inquiries)
Government_Sales-USA@supermicro.com (Gov. Sales Inquiries)
support@supermicro.com (Technical Support)
RMA@supermicro.com (RMA Support)
Webmaster@supermicro.com (Webmaster)

Website: www.supermicro.com

Europe

Address: Super Micro Computer B.V.
Het Sterrenbeeld 28, 5215 ML
's-Hertogenbosch, The Netherlands

Tel: +31 (0) 73-6400390

Fax: +31 (0) 73-6416525

Email: Sales_Europe@supermicro.com (Sales Inquiries)
Support_Europe@supermicro.com (Technical Support)
RMA_Europe@supermicro.com (RMA Support)

Website: www.supermicro.nl

Asia-Pacific

Address: Super Micro Computer, Inc.
3F, No. 150, Jian 1st Rd.
Zhonghe Dist., New Taipei City 235
Taiwan (R.O.C)

Tel: +886-(2) 8226-3990

Fax: +886-(2) 8226-3992

Email: Sales-Asia@supermicro.com.tw (Sales Inquiries)
Support@supermicro.com.tw (Technical Support)
RMA@supermicro.com.tw (RMA Support)

Website: www.supermicro.com.tw

Chapter 1

Introduction

1.1 Overview

This chapter provides a brief outline of the functions and features of the SuperServer SYS-221GE-TNHT-LC1. This is a liquid-cooled system based on the X13DEG-R motherboard and the CSE-228G2TS-R5K25P chassis.

The following provides an overview of the specifications and capabilities of the system.

System Overview	
Motherboard	X13DEG-R
Chassis	CSE-228G2TS-R5K25P
Processor Support	Supports dual 4th/5th Gen Intel Xeon Scalable/ Xeon Max Series processors (in Socket E LGA 4677) with four UPIs (20 GT/s maximum) with up to 64 cores and a Thermal Design Power (TDP) of up to 350 W
Chipset	Intel C741
Memory	Supports up to 8 TB of 3DS RDIMM/RDIMM DDR5 (288-pin) ECC memory with speeds of up to 5600 MT/s (1DPC) in 32 DIMM slots Note: Memory speed and capacity support depends on the processor.
GPU	HGX H100 4-GPU SXM5 Multi-GPU Board PCIe 5.0 x16 CPU-to-GPU Interconnect, NVIDIA NVLink with NVSwitch (up to 700 W)
Drive Support	Four hot-swap 2.5" SATA/NVMe drive bays
Expansion Slots	Four low-profile x16 PCIe 5.0 slots Two onboard M.2 slots in the 22110/2280 form factor
I/O Ports	Via the I/O board AOM-PTG-I2T: Two 10 G Ethernet LAN ports One dedicated BMC LAN port Two USB 3.0 ports One VGA port
System Cooling	Four hot-swap 80-mm, counter-rotating PWM fans; one air shroud, liquid-cooled CPU and GPU
Power	Dual 5250 W (1+1) power supplies
Form Factor	2U rackmount, (WxHxD) 17.2 x 3.5 x 32.7 in (437 x 89 x 830.3 mm)

A Quick Reference Guide can be found on the [product page](#) of the Supermicro website. The following safety models associated with the SYS-221GE-TNHT-LC1 have been certified as compliant with UL or CSA: 228GLC-R52X13, 228GLC-52, 228GLC-GPU.

1.2 System Features

The CSE-228G2TS-R5K25P is a 2U chassis that supports four hot-swappable 2.5" SATA/ NVMe drives and four hot-swappable fans at the front. Two power supplies, four expansion slots, I/O ports, and liquid-cooling ports are supported at the rear.

Front View

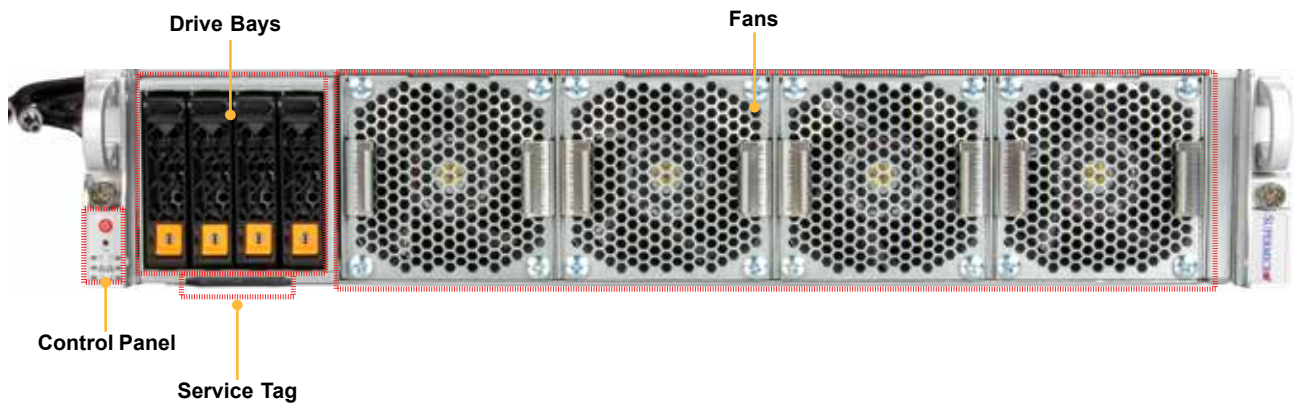

Figure 1-1. Front View

System Features: Front	
Feature	Description
Drive Bays	Four hot-swap 2.5" SATA/NVMe drive bays
Fans	Four hot-swappable system cooling fans
Control Panel	Described on the next page
Service Tag	Pull-out service tag

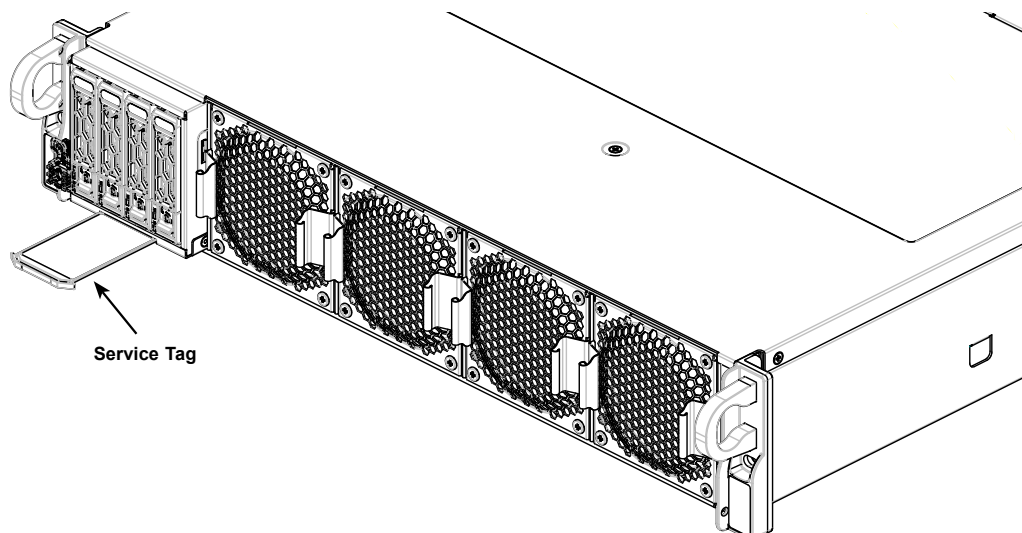

Figure 1-2. Location of Service Tag

Control Panel

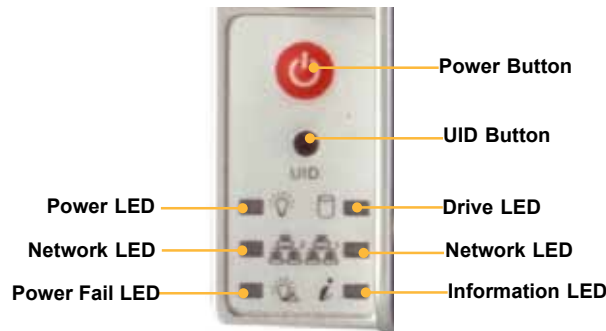

Figure 1-3. Control Panel

Control Panel Features	
Feature	Description
Power Button	The main power button applies or removes primary power from the power supply to the server but maintains standby power. To perform most maintenance tasks, unplug the rear power cables completely from the system and wait 30 seconds for capacitors to discharge.
UID Button	Use a pin to press the UID button
Power LED	Indicates power is being supplied to the system power supply units. This LED is illuminated when the system is operating normally.
Drive LED	Indicates drive activity.
Network LEDs	Indicates network activity on LAN when flashing.
Information LED	Alerts operator to several states, as noted in the table below.
Power Fail LED	Indicates a power supply module has failed.

Information LED	
Color, Status	Description
Red, solid	An overheat condition has occurred.
Red, blinking at 1 Hz	Fan failure, check for an inoperative fan.
Red, blinking at 0.25 Hz	Power failure, check for a non-operational power supply.
Red, solid, with Power LED blinking green	Fault detected
Blue and red, blinking at 10 Hz	Recovery mode
Blue, solid	UID has been activated locally to locate the server in a rack environment.
Blue, blinking at 1 Hz	UID has been activated using the BMC to locate the server in a rack environment.
Blue, blinking at 2 Hz	BMC is resetting
Blue, blinking at 4 Hz	BMC is setting factory defaults
Blue, blinking at 10 Hz with Power LED blinking green	BMC/BIOS firmware is updating

Rear View

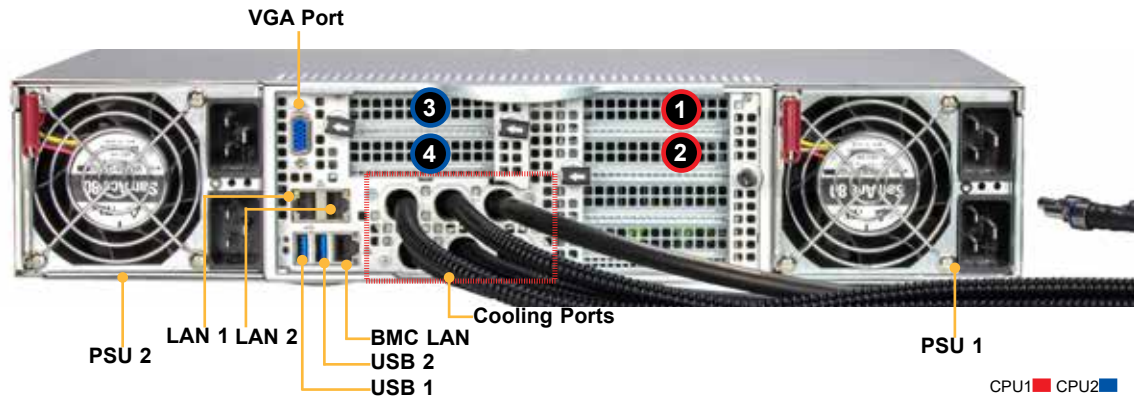

Figure 1-4. Rear View

System Features: Rear	
Feature	Description
PSU 1, PSU 2	Two hot swappable power supplies
VGA Port	Video port
LAN 1, LAN 2	Two 10 Gigabit-aggregate Ethernet LAN ports
USB 1, USB 2	Two USB 3.0 ports
BMC LAN	BMC LAN port
Cooling Ports	Liquid-cooling ports
Slots 1 and 2	Two PCIe 5.0 x16 FH, 2.5"L slots supported on first riser card by CPU1
Slots 3 and 4	Two PCIe 5.0 x16 FH, 2.5"L slots supported on second riser card by CPU2

Full-height = 4.2", Low-profile = 2.5", Full-length = 10.5", Half-length = 6.6"

Important: Only Laser Class 1 optical transceivers shall be used.

Top View

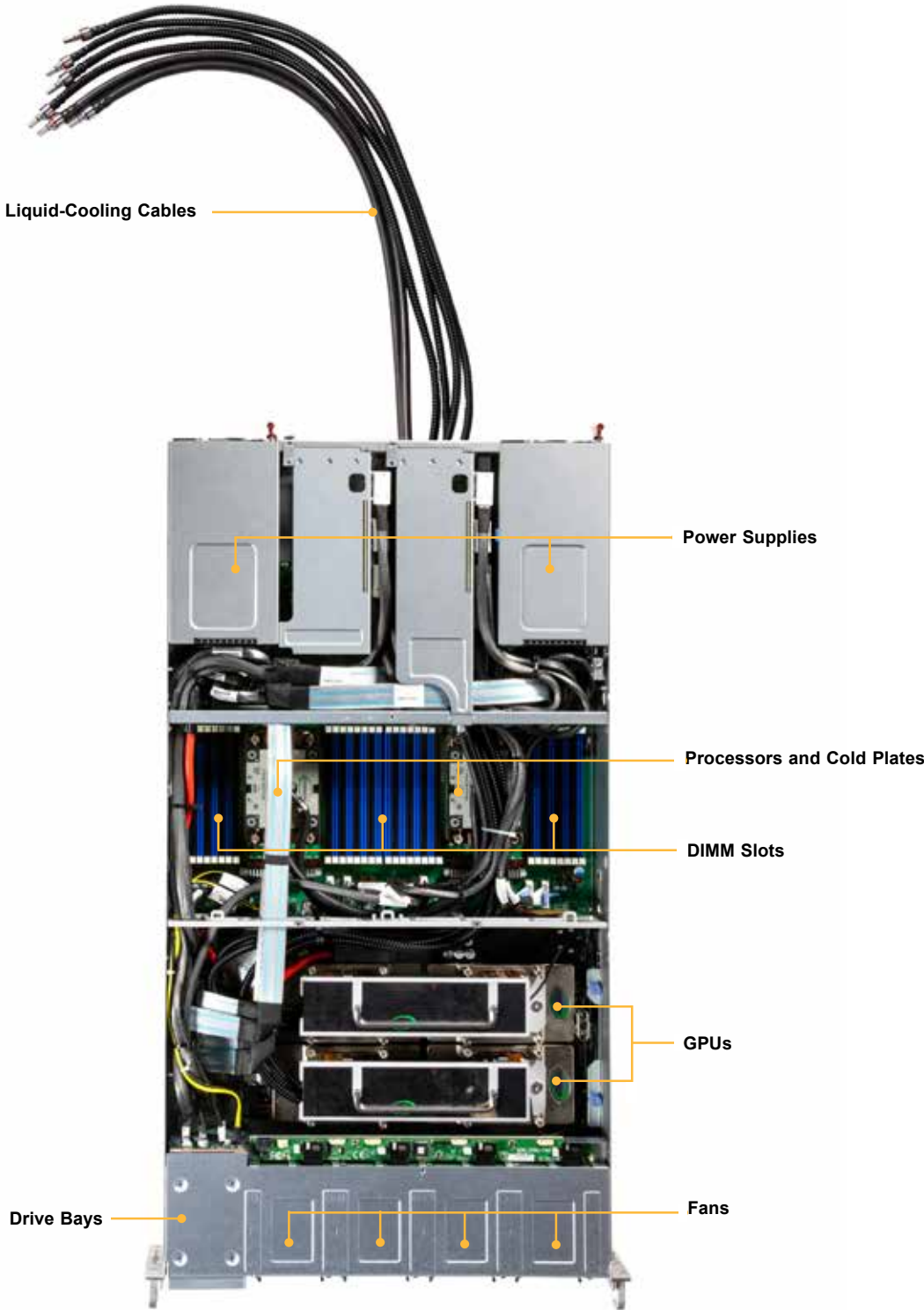

Figure 1-5. Top View

System Features: Top	
Feature	Description
Liquid-Cooling Cables	Cables from the GPU and CPU cold plates
Power Supplies	Dual 5250 W (1+1) power supplies
Processors and Cold Plates	Dual 4th/5th Gen Intel Xeon Scalable Processor
DIMM Slots	32 DIMM slots
GPUs	Four NVIDIA H100 GPUs
Fans	Four hot-swap 80-mm fans
Drive Bays	Four drive bays

1.3 System Architecture

This section covers the printed circuit board (PCB) locations.

Printed Circuit Board Locations

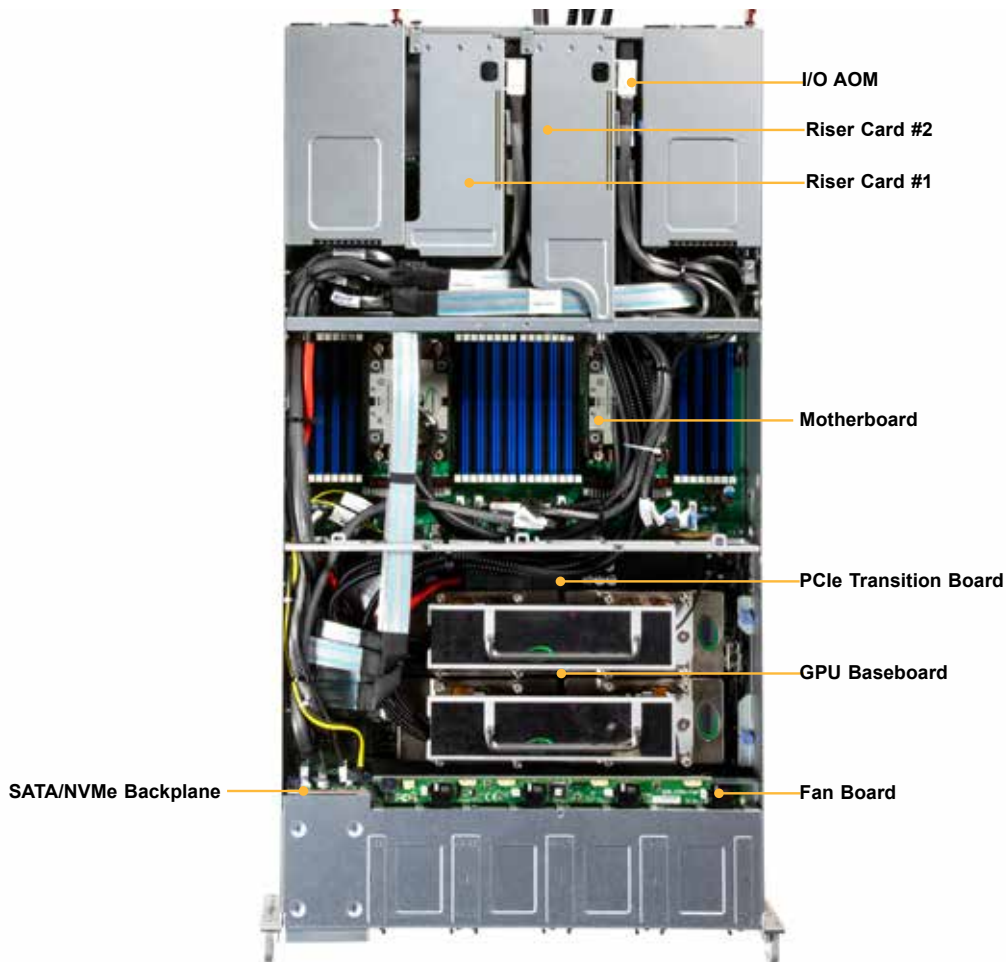

Figure 1-6. Circuit Board Locations

Printed Circuit Boards	
Feature	Description
I/O AOM	AOM connects to the motherboard and provides rear I/O ports
Two Riser Cards	Two RSC-G-66G5+ cards providing four low-profile PCIe 5.0 x16 slots
Motherboard	X13DEG-R
PCIe Transition Board	Board supports the GPU baseboard
GPU Baseboard	Nvidia's HGX H100 SXM5 baseboard with NVlink GPU-GPU interconnect and PCIe 5.0 GPU-CPU connections
Fan Board	Circuit board that connects four external fans and cables to the motherboard
SATA/NVMe Backplane	Backplane supporting four hot-swappable 2.5" SATA/NVMe drives

Data Plane Block Diagram

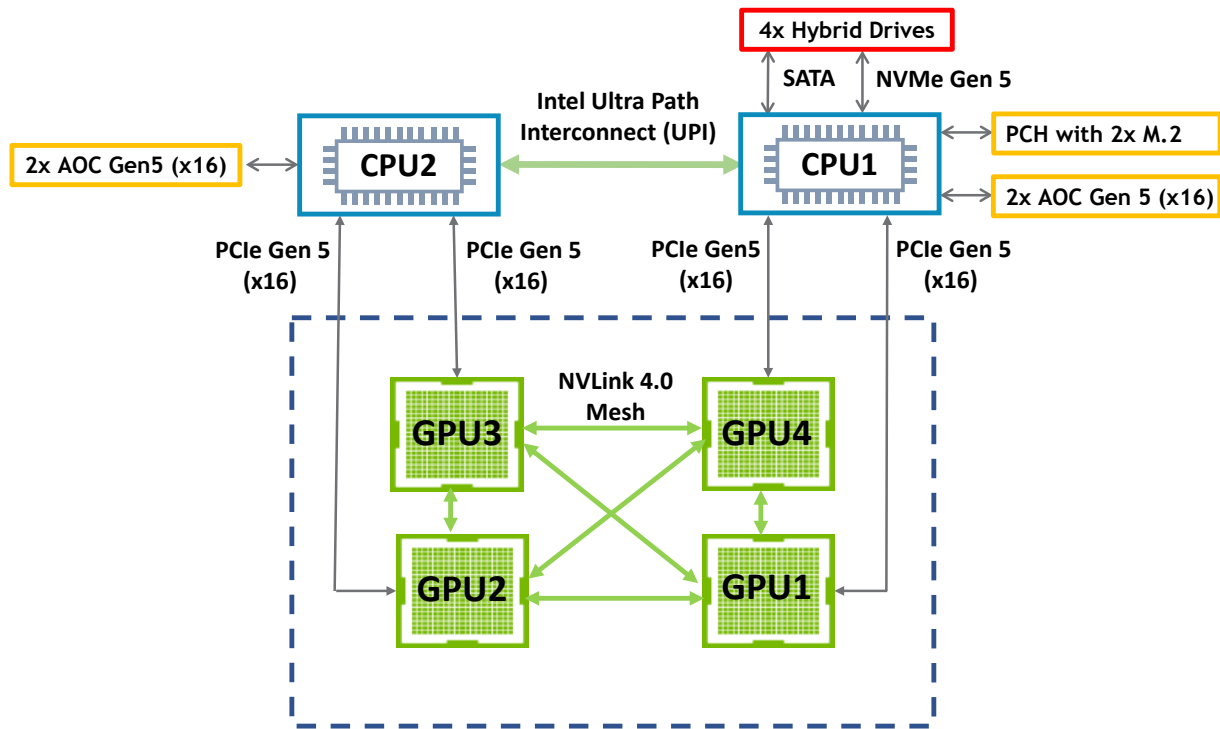

Figure 1-7. System Architecture Block Diagram: Data Plane

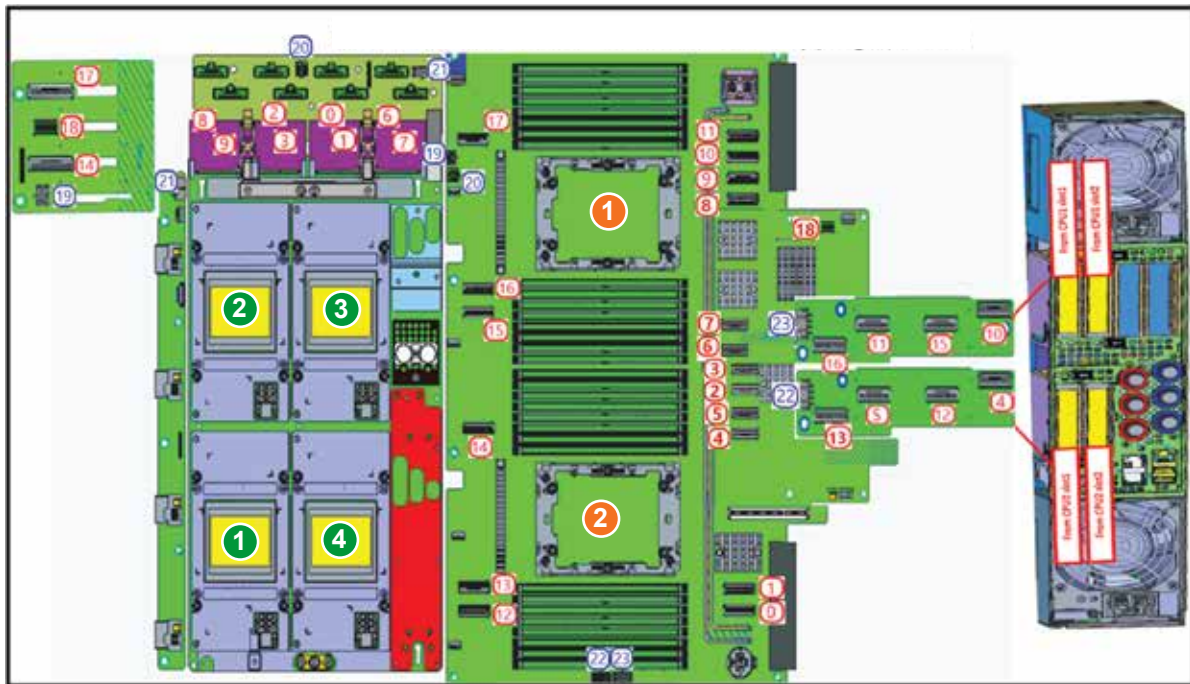

Figure 1-8. Cable Mapping Guide

Note: The GPU numbering in the figure above is based on BMC interface numbering. See the GPU mapping table for more information.

CPU Mapping Table	
Item	CPU Physical Location
1	CPU1
2	CPU2

Power Cable Mapping Table				
Cable#	Cable Part Number	Length	Description	Function
19	CBL-PWEX-1131-40	40 cm	Micro Hi	Storage Drive Backplane and Motherboard
20	CBL-PWEX-1131-30	30 cm	Micro Hi	GPU Transition Board and Motherboard
21	CBL-PWEX-1090B-30	30 cm	Micro Power	GPU Transition Board and Fan Baseboard
22	CBL-PWEX-1114-30	30 cm	Microfit	Motherboard and Riser Card 2
23	CBL-PWEX-1114-30	30 cm	Microfit	Motherboard and Riser Card 1

GPU and CPU Mapping Table			
Item	BMC Interface Numbering	GPU Physical Location	Linux OS Numbering
①	GPU1	GPU1	GPU1
②	GPU2	GPU2	GPU3
③	GPU3	GPU3	GPU2
④	GPU4	GPU4	GPU0

Data Cable Mapping Table						
Cable#	Cable P/N	Length	Lanes	MB Connector Name: Reference Designator	CPU	Function
0	CBL-MCIO-1385M5FXB1-E	80-85 cm	x8	JMCIO6A	CPU2	MCIO Connectors for GPU Transition Board
1	CBL-MCIO-1385M5FXB1-E	80-85 cm	x8	JMCIO6B	CPU2	MCIO Connectors for GPU Transition Board
2	CBL-MCIO-1371M5FXB2-E	66-71 cm	x8	JMCIO7A	CPU2	MCIO Connectors for GPU Transition Board
3	CBL-MCIO-1371M5FXB2-E	66-71 cm	x8	JMCIO7B	CPU2	MCIO Connectors for GPU Transition Board
4	CBL-MCIO-1337M5L	37 cm	x8	JMCIO8A	CPU2	MCIO Connectors for Riser Cards
5	CBL-MCIO-1330M5L	30 cm	x8	JMCIO8B	CPU2	MCIO Connectors for Riser Cards
6	CBL-MCIO-1354M5FXB3-X	48-54 cm	x8	JMCIO1A	CPU1	MCIO Connectors for GPU Transition Board
7	CBL-MCIO-1354M5FXB3-X	48-54 cm	x8	JMCIO1B	CPU1	MCIO Connectors for GPU Transition Board
8	CBL-MCIO-1357M5FXB4-X	56-57 cm	x8	JMCIO2A	CPU1	MCIO Connectors for GPU Transition Board
9	CBL-MCIO-1357M5FXB4-X	56-57 cm	x8	JMCIO2B	CPU1	MCIO Connectors for GPU Transition Board
10	CBL-MCIO-1337M5L	37 cm	x8	JMCIO3A	CPU1	MCIO Connectors for Riser Cards
11	CBL-MCIO-1337M5L	37 cm	x8	JMCIO3B	CPU1	MCIO Connectors for Riser Cards
12	CBL-MCIO-1343M5L	43 cm	x8	JMCIO10A	CPU2	MCIO Connectors for Riser Cards
13	CBL-MCIO-1337M5L	37 cm	x8	JMCIO10B	CPU2	MCIO Connectors for Riser Cards
14	CBL-MCIO-1250M5-Z	50 cm	x8	JMCIO9A	CPU2	MCIO Connectors for Storage Devices
15	CBL-MCIO-1250M5L	50 cm	x8	JMCIO5A	CPU1	MCIO Connectors for Riser Cards
16	CBL-MCIO-1343M5L	43 cm	x8	JMCIO5B	CPU1	MCIO Connectors for Riser Cards
17	CBL-MCIO-1330M5	30 cm	x8	JMCIO4A	CPU1	MCIO Connectors for Storage Devices
18	CBL-SAST-1272-100	72 cm	x4	JS1	PCH	SlimSAS LP Connector for four Intel PCH SATA 3.0 connections

Quick Reference Table

Jumper	Description	Settings
JBT1	CMOS Clear	Open (Normal)
JRU1	UID Swtich/BMC Reset/System Reset	Pins 1-2: System Reset Pins 2-3: UID Swtich/BMC Reset (Default)

LED	Description	Status
LED_UID	Unit Identifier (UID) LED	Solid Blue: Unit Identified
LEDBMC	BMC Heartbeat LED	Blinking Green: BMC Normal (Active) Solid Green: During BMC Reset or during a Cold Reboot
LEDM2A, LEDM2B	M.2 LEDs	Blinking Green: Device Working
LEDPWR	Power LED	LED On: Onboard Power On
LEDRT1_0, LEDRT1_1, LEDRT1_2	Retimer Status LED	Working Normally when LEDRT1_0 (Solid On), LEDRT1_1 (Blinking), and LEDRT1_2 (Solid On)
LEDRT2_0, LEDRT2_1, LEDRT2_2	Retimer Status LED	Working Normally when LEDRT2_0 (Solid On), LEDRT2_1 (Blinking), and LEDRT2_2 (Solid On)
LEDRT3_0, LEDRT3_1, LEDRT3_2	Retimer Status LED	Working Normally when LEDRT3_0 (Solid On), LEDRT3_1 (Blinking), and LEDRT3_2 (Solid On)
LEDRT4_0, LEDRT4_1, LEDRT4_2	Retimer Status LED	Working Normally when LEDRT4_0 (Solid On), LEDRT4_1 (Blinking), and LEDRT4_2 (Solid On)

Connector	Description
BT1	Onboard CMOS Battery
JBPN_PWR1	4-pin Power Connector to the Storage Backplane
JBRG_PWR1	4-pin Power Connector to the GPU Transition Board
JCPLD2	Complex Programmable Logic Device (CPLD) Header
JFP1	Front Control Panel Header
JGPU_PWR1	Power Connector for the GPU Module
JIPMB1	4-pin BMC External I ² C Header
JL1	Chassis Intrusion Header
JMCIO1A, JMCIO1B, JMCIO2A, JMCIO2B, JMCIO6A, JMCIO6B, JMCIO7A, JMCIO7B	PCIe 5.0 x8 MCIO Connectors for the GPU Transition Board
JMCIO3A, JMCIO3B, JMCIO5A, JMCIO5B, JMCIO8A, JMCIO8B, JMCIO10A, JMCIO10B	PCIe 5.0 x8 MCIO Connectors for Riser Cards

Connector	Description
JMCIO4A, JMCIO9A	PCIe 5.0 x8 MCIO Connectors for Storage Devices
JNCSI1	Network Controller Sideband Interface (NC-SI) Connector
JPRG1	Connector reserved for manufacturer use for onboard Complex Programmable Logic Device (CPLD) firmware programming
JPSU1, JPSU2	5.25 Kilowatt (KW) Power Supply Unit Connectors
JRK1	Intel VROC Key Header
JRSC_PWR1, JRSC_PWR2	8-pin Riser Card Power Connectors
JS1 (SATA 0-3)	SlimSAS LP PCIe x4 Connector with support of four Intel PCH SATA 3.0 connections (6 Gb/second, support RAID 0/1/5/10)
JSLOT1	AOM Riser Card Slot (with support of the AOM-PTG-I2T riser card installed to provide connections of one dedicated BMC LAN port, two USB 3.0 ports, one VGA header, one COM header, and dual 10 GbE LAN ports)
JTPM1	Trusted Platform Module/Port 80 Connector
JUSB1 (USB0)	Internal USB 3.0 Vertical Type-A Connector
LCSEN1 – LCSEN4	Leakage Sensor Board Connectors
M.2-P1, M.2-P2	PCIe 3.0 x4 NVMe M.2 Slots (with support of M-Key 2280/22110)

Motherboard Block Diagram

X13DEG-R

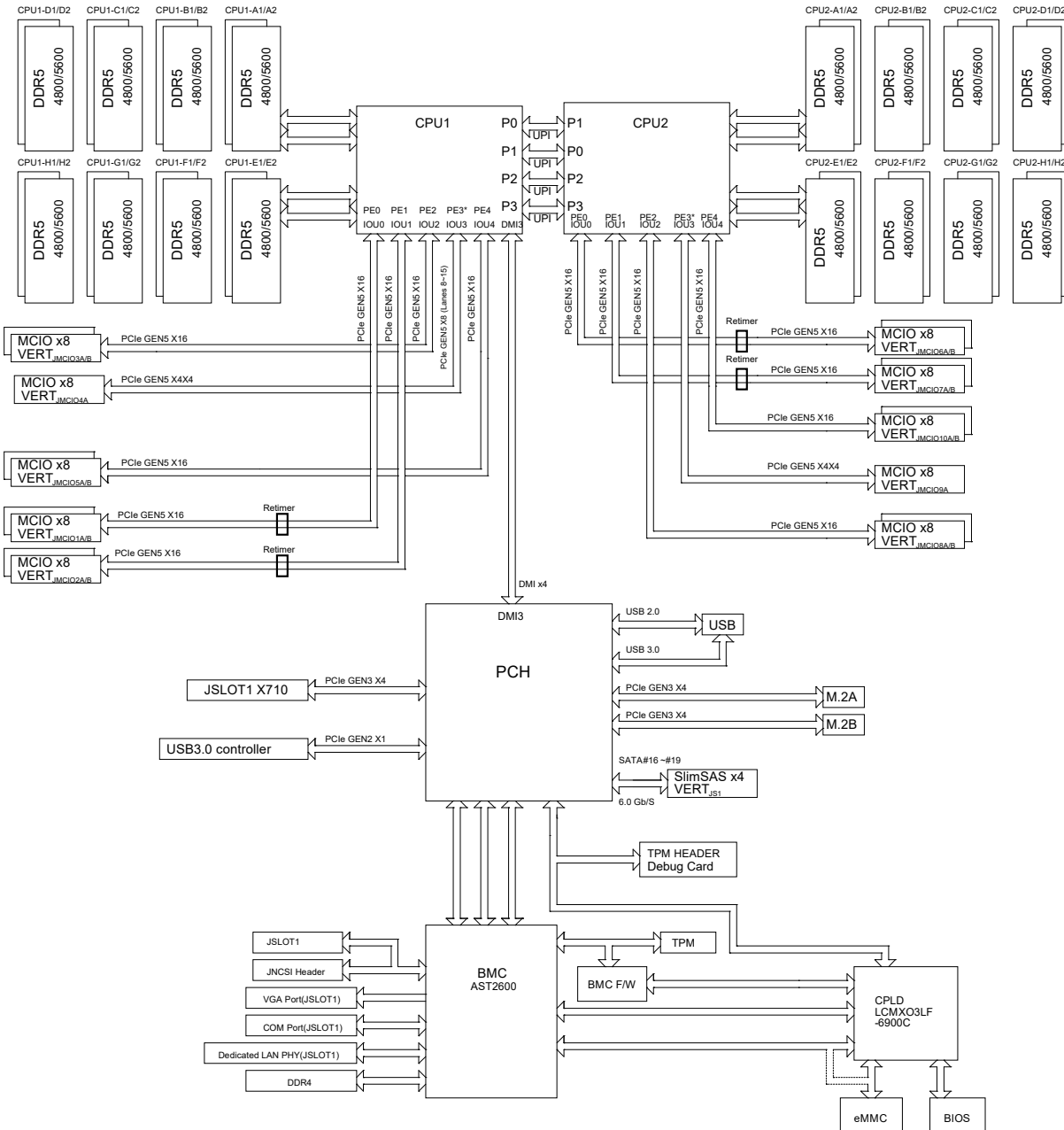

Figure 1-10. Motherboard Block Diagram

1.5 Where to Get Replacement Components

If you need replacement parts for your system, to ensure the highest level of professional service and technical support, purchase exclusively from our Supermicro Authorized Distributors/System Integrators/Resellers. A list can be found at: <http://www.supermicro.com>. Click the "Where to Buy" link.

1.6 Returning Merchandise for Service

A receipt or copy of your invoice marked with the date of purchase is required before any warranty service will be rendered. You can obtain service by calling your vendor for a Returned Merchandise Authorization (RMA) number. When returning to the manufacturer, the RMA number should be prominently displayed on the outside of the shipping carton, and mailed prepaid or hand-carried. Shipping and handling charges will be applied for all orders that must be mailed when service is complete.

For faster service, RMA authorizations may be requested online (<http://www.supermicro.com/support/rma/>).

Whenever possible, repack the chassis in the original Supermicro carton, using the original packaging material. If these are no longer available, be sure to pack the chassis securely, using packaging material to surround the chassis so that it does not shift within the carton and become damaged during shipping.

This warranty only covers normal consumer use and does not cover damages incurred in shipping or from failure due to the alteration, misuse, abuse or improper maintenance of products.

During the warranty period, contact your distributor first for any product problems.

Chapter 2

Server Installation

2.1 Overview

This chapter provides advice and instructions for mounting your system in a server rack. If your system is not already fully integrated with processors, system memory, etc., refer to [Chapter 3](#) for details on installing those specific components.

Important: Electrostatic Discharge (ESD) can damage electronic components. To prevent such damage to PCBs (printed circuit boards), it is important to use a grounded wrist strap, handle all PCBs by their edges and keep them in anti-static bags when not in use.

2.2 Unpacking the System

Inspect the box in which the system was shipped, and note if it was damaged in any way. If any equipment appears damaged, file a damage claim with the carrier who delivered it.

Decide on a suitable location for the rack unit that will hold the server. It should be situated in a clean, dust-free area that is well ventilated. Avoid areas where heat, electrical noise, and electromagnetic fields are generated. It will also require a grounded AC power outlet nearby. Be sure to read the precautions and considerations noted or in [Appendix A](#).

2.3 Preparing for Setup

The box in which the system was shipped should include the rackmount hardware needed to install it into the rack. Please read this section in its entirety before you begin the installation.

Choosing a Setup Location

- The system should be situated in a clean, dust-free area that is well ventilated. Avoid areas where heat, electrical noise, and electromagnetic fields are generated.
- Leave enough clearance in front of the rack so that you can open the front door completely (approximately 25 inches) and approximately 30 inches of clearance in the back of the rack to allow sufficient space for airflow and access when servicing.
- This product should be installed only in a Restricted Access Location (dedicated equipment rooms, service closets, etc.).

- This product is not suitable for use with visual display workplace devices according to §2 of the German Ordinance for Work with Visual Display Units.

Rack Precautions

- Ensure that the leveling jacks on the bottom of the rack are extended to the floor so that the full weight of the rack rests on them.
- In single rack installations, stabilizers should be attached to the rack. In multiple rack installations, the racks should be coupled together.
- Always make sure the rack is stable before extending a server or other component from the rack.
- You should extend only one server or component at a time - extending two or more simultaneously may cause the rack to become unstable.

Server Precautions

- Review the electrical and general safety precautions in [Appendix A](#).
- Determine the placement of each component in the rack *before* you install the rails.
- Install the heaviest server components at the bottom of the rack first and then work your way up.
- Use a regulating uninterruptible power supply (UPS) to protect the server from power surges and voltage spikes and to keep your system operating in case of a power failure.
- Allow any drives and power supply modules to cool before touching them.
- When not servicing, always keep the front door of the rack and all covers/panels on the servers closed to maintain proper cooling.

Rack Mounting Considerations



Warning! Stability hazard. The rack may tip over causing serious personal injury. Before extending the rack to the installation position, read the installation instructions. Do not put any load on the slide-rail mounted equipment in the installation position. Do not leave the slide-rail mounted equipment in the installation position.



Avertissement! Danger d'instabilité. Le rack peut basculer et provoquer des blessures corporelles graves. Avant d'étendre le rack en position d'installation, lire les instructions d'installation. Ne pas charger l'équipement monté sur rail de glissière en position d'installation. Ne pas laisser l'équipement monté sur rail de glissière en position d'installation.

Important: To prevent bodily injury when mounting or servicing this unit in a rack, you must take special precautions to ensure that the system remains stable. The following guidelines are provided to ensure your safety:

- This unit should be mounted at the bottom of the rack if it is the only unit in the rack.
- When mounting this unit in a partially filled rack, load the rack from the bottom to the top with the heaviest component at the bottom of the rack.
- If the rack is provided with stabilizing devices, install the stabilizers before mounting or servicing the unit in the rack.
- Slide rail mounted equipment is not to be used as a shelf or a work space.

Ambient Operating Temperature

If installed in a closed or multi-unit rack assembly, the ambient operating temperature of the rack environment may be greater than the room's ambient temperature. Therefore, consideration should be given to installing the equipment in an environment compatible with the manufacturer's maximum rated ambient temperature (TMRA).

Airflow

Equipment should be mounted into a rack so that the amount of airflow required for safe operation is not compromised.

Mechanical Loading

Equipment should be mounted into a rack so that a hazardous condition does not arise due to uneven mechanical loading.

Circuit Overloading

Consideration should be given to the connection of the equipment to the power supply circuitry and the effect that any possible overloading of circuits might have on overcurrent protection and power supply wiring. Appropriate consideration of equipment nameplate ratings should be used when addressing this concern.

Reliable Ground

A reliable ground must be maintained at all times. To ensure this, the rack itself should be grounded. Particular attention should be given to power supply connections other than the direct connections to the branch circuit (i.e. the use of power strips, etc.).

2.4 Installing the Rails

This section provides information on installing the chassis into a rack unit with the rails provided. There are a variety of rack units on the market, which may mean that the assembly procedure will differ slightly from the instructions provided. You should also refer to the installation instructions that came with the rack unit you are using. **Note:** This rail will fit a rack between 28" and 33.5" deep.

Identifying Sections of the the Rails

The package includes two rail assemblies. Each is specifically designed for the left or right side of the chassis, and so marked. Each rail consists of two sections: a front section which secures to the front post of the rack and a rear section which adjusts in length and secures to the rear post of the rack.

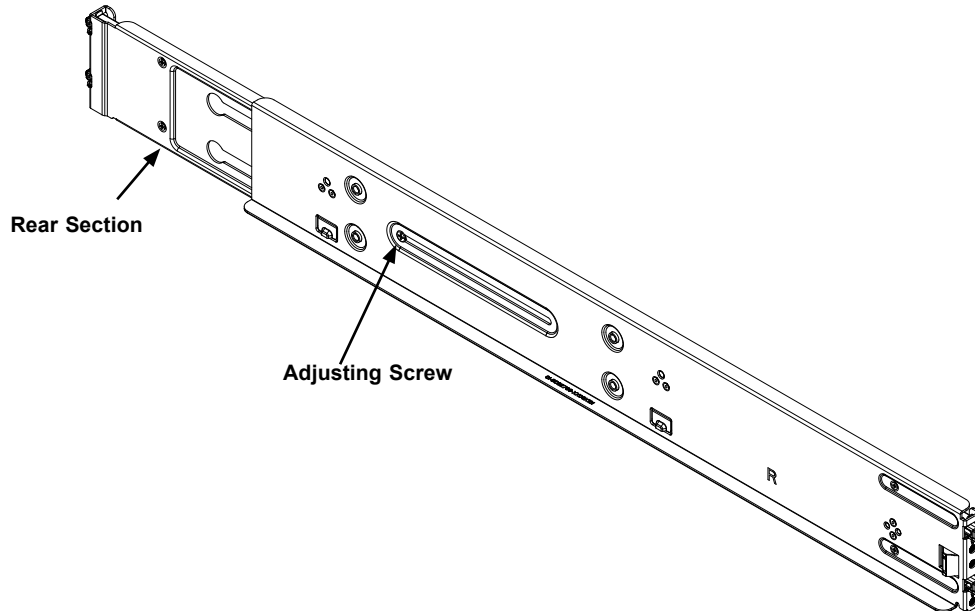

Figure 2-1. Rackmount Rail
(Right rail assembly shown)

Adjusting the Rail Length

Each rail assembly has a locking screw to adjust the length of the rail to fit the depth of your rack.

Installing the Outer Rails onto the Rack

Important: Stability hazard. The rack stabilizing mechanism must be in place, or the rack must be bolted to the floor before you slide the unit out for servicing. Failure to stabilize the rack can cause the rack to tip over.

Important: Do not pick up the server with the front handles. They are designed to pull the system from a rack only.

1. Loosen the adjusting screw to allow the rear section to slide in the front section.
2. Push the small hooks on the front section of the rail into the holes on the front post of the rack and then down, until the spring-loaded pegs snap into the rack holes. Secure the rail to the rack with screws.
3. Pull out the rear section of the outer rail, adjusting the length until it fits within the posts of the rack and align the small hooks with the appropriate holes on the rear post of the rack. Be sure the rail is level, then mount the rear section onto the rack. Secure the rail with screws.
4. Tighten the adjusting screw.

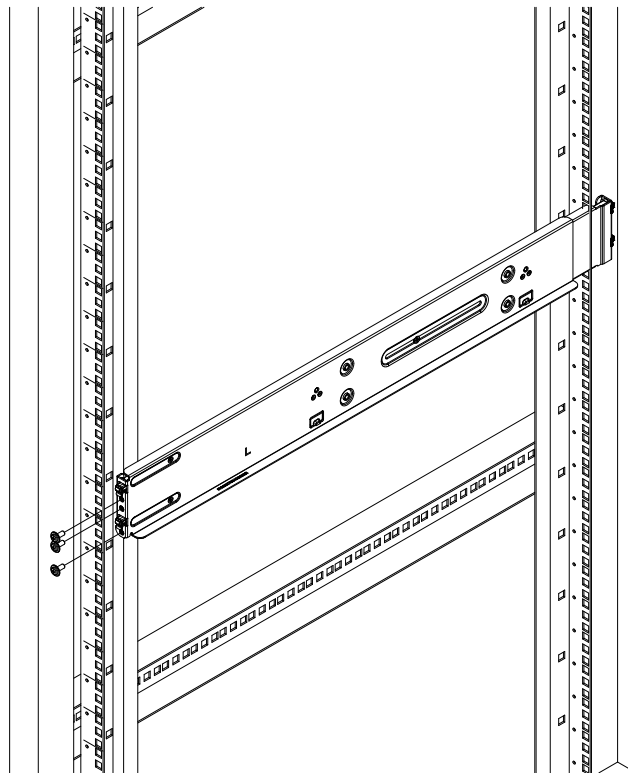

Figure 2-2. Attaching the Rail Front to the Rack
(Left Rail Shown)

Note: Figures are for illustrative purposes only. Always install servers into racks from the bottom up.

2.5 Installing the Chassis into a Rack

Once the rails are attached to the chassis and the rack, you can install the chassis. Slide the chassis into the rack so that the bottom of the chassis slides onto the bottom lip of the rails. Then use the thumbscrews on the chassis front to secure the system.

Important: Use caution when mounting or removing the system from the rack. For large systems, at least one other person should assist during installation or removal. Follow the safety recommendations printed on the rails.

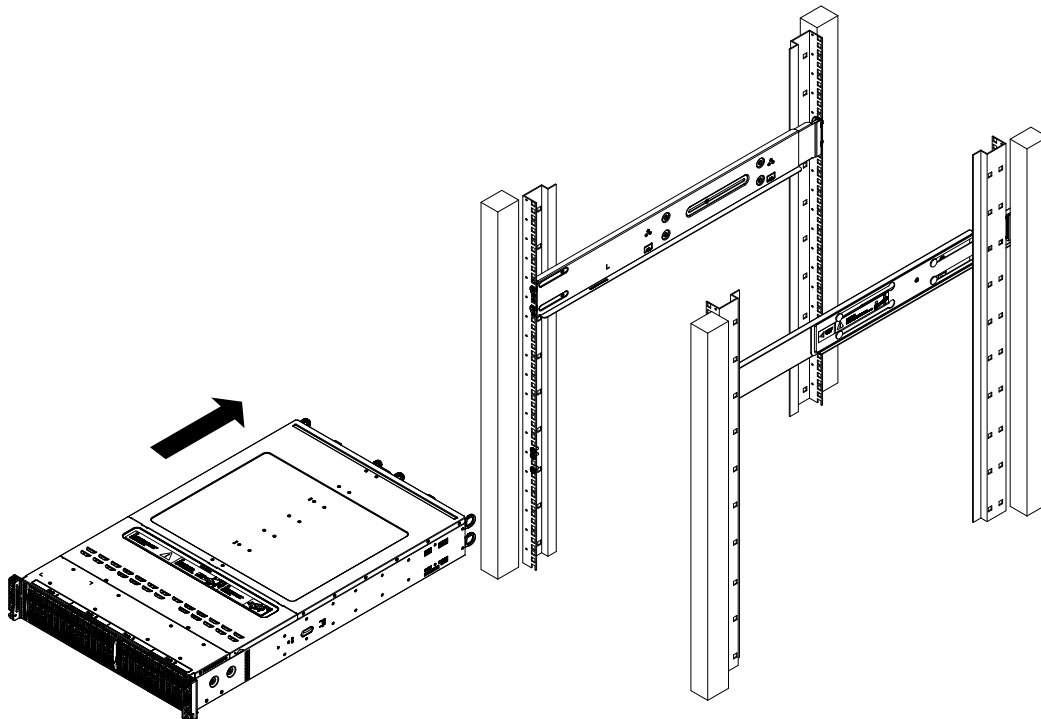

Figure 2-3. Installing the Chassis into the Rack

Note: Figures are for illustrative purposes only. Always install servers into racks from the bottom up.

2.6 Removing the Chassis into a Rack

Important: It is dangerous for a single person to off-load the heavy chassis from the rack without assistance. Be sure to have sufficient assistance supporting the chassis when removing it from the rack. Use a lift.

Loosen the thumbscrews and slide the chassis out of the rack.

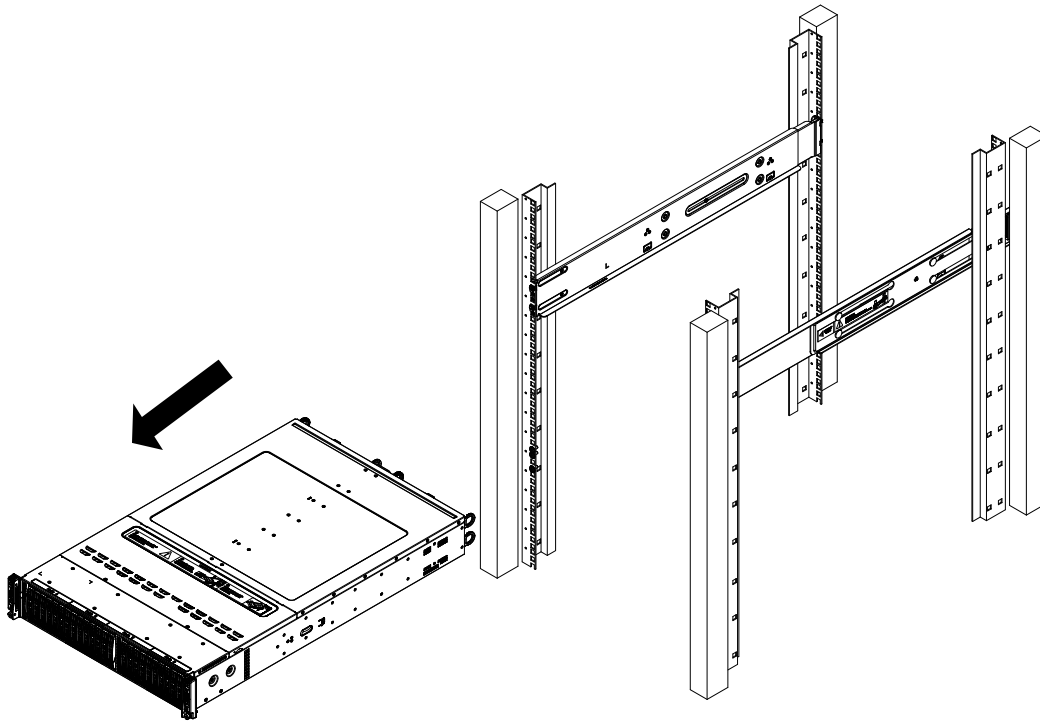

Figure 2-4. Removing the Chassis from the Rack

2.7 Connecting to a Coolant Distribution Unit (CDU)

Important: The chassis is heavy and requires two to three people to lift it.

The SYS-221GE-TNHT-LC1 server uses a liquid-cooling solution to maintain operational temperature. The coolant from the chassis is circulated out to an external Coolant Distribution Unit (CDU) using specialized pipes and tubes, where it is cooled through a cooling tower or cooling unit, and circulated back to the CDU and back to the chassis.

A brief layout of the relationship between the devices is shown below.

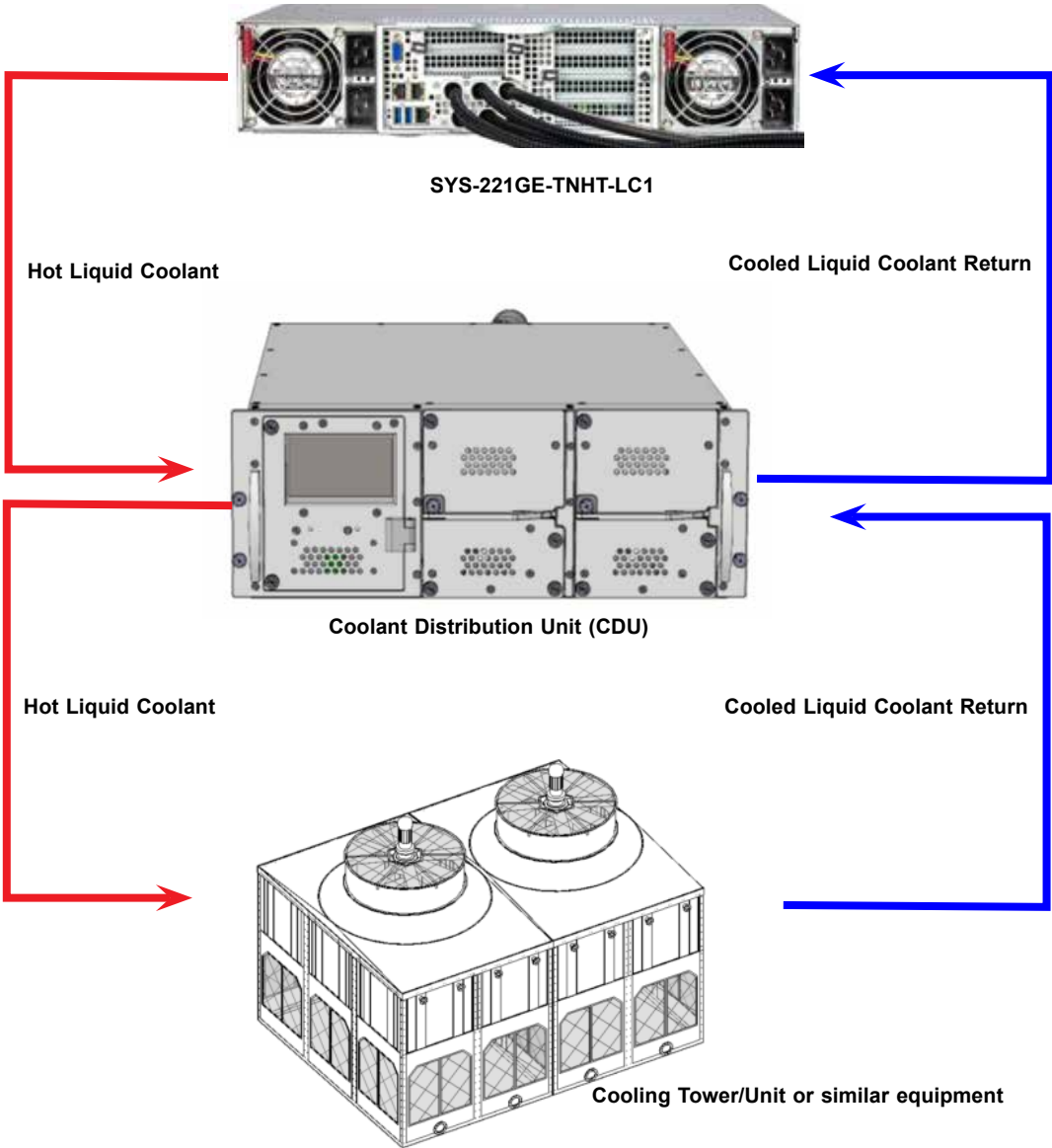

Figure 2-5. Liquid-Cooling Layout

Chapter 3

Maintenance and Component Installation

This chapter provides instructions on installing and replacing main system components. To prevent compatibility issues, only use components that match the specifications and/or part numbers given.

Installation or replacement of most components requires that power first be removed from the system. Please follow the procedures given in each section.

3.1 Removing Power

Use the following procedure to ensure that power has been removed from the system. This step is necessary when removing or installing non-hot-swap components or when replacing a non-redundant power supply.

1. Use the operating system to power down the system.
2. After the system has completely shut-down, disconnect the AC power cord(s) from the power strip or outlet. (If your system has more than one power supply, remove the AC power cords from all power supply modules.)
3. Disconnect the power cord(s) from the power supply module(s).

3.2 Accessing the System

The CSE-228G2TS-R5K25P has a removable two-piece top cover. Check that all ventilation openings in the chassis are clear and unobstructed.

Important: Except for short periods of time, do not operate the server without the cover in place. The chassis cover must be in place to allow for proper airflow and to prevent overheating.

Removing the Top Cover

1. Remove four side screws and one top screw from the front cover.
2. Remove six side screws and three top screws from the rear cover.
3. Push the rear top cover towards the rear of the unit, which will separate the two top covers. Now each top cover can be removed by lifting them up.

Important: High voltage (54 V) is present in the system.

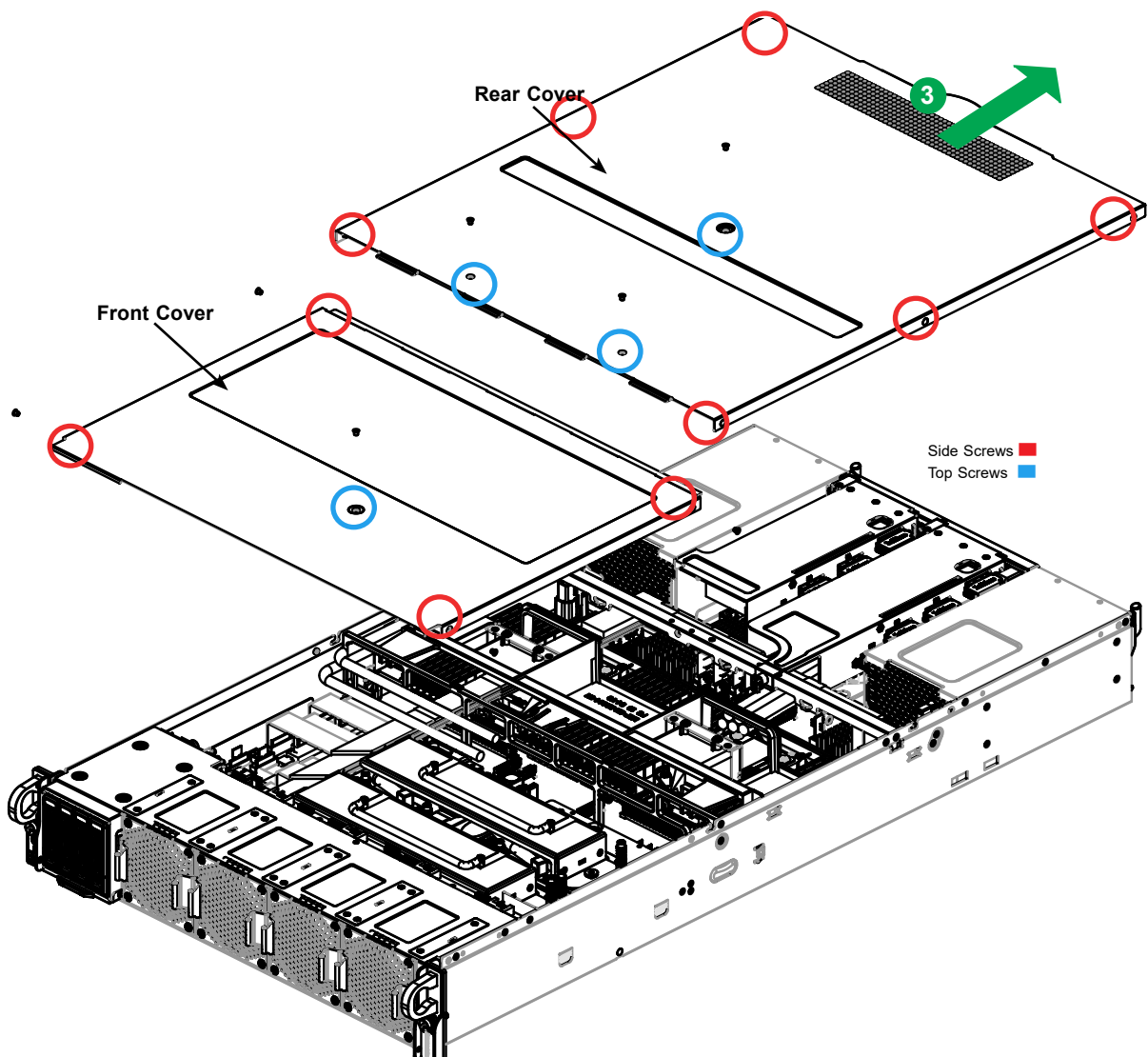

Figure 3-1. Removing the Chassis Cover

3.3 Static-Sensitive Devices

Electrostatic Discharge (ESD) can damage electronic components. To avoid damaging your motherboard, it is important to handle it very carefully. The following measures are generally sufficient to protect your equipment from ESD.

Precautions

- Use a grounded wrist strap designed to prevent static discharge.
- Touch a grounded metal object before removing the board from the antistatic bag.
- Handle the motherboard by its edges only. Do not touch its components, peripheral chips, memory modules, or gold contacts.
- When handling chips or modules, avoid touching their pins.
- Put the motherboard and peripherals back into their antistatic bags when not in use.
- For grounding purposes, make sure that your computer chassis provides excellent conductivity between the power supply, the case, the mounting fasteners, and the motherboard.
- Use only the correct type of onboard CMOS battery. Do not install the onboard battery upside down to avoid possible explosion.

3.4 Memory Support and Installation

Important: Exercise extreme care when installing or removing DIMM modules to prevent any possible damage.

Note: Check the Supermicro website for recommended memory modules.

Memory Support

This motherboard supports up to 8 TB of 3DS RDIMM/RDIMM DDR5 (288-pin) ECC memory with speeds of up to 5600 MT/s (1DPC) in 32 DIMM slots.

Note: Memory speed and capacity support depend on the processor.

DDR5 Memory Support for the 4th Gen. Intel Xeon Scalable Processors

DDR5 Memory Support for the 4th Gen. Intel Xeon Scalable Processors					
Type	Ranks Per DIMM & Data Width (Stack)	DIMM Capacity (GB)		Speed (MT/s); Voltage (V); DIMM Per Channel (DPC)	
				1DPC*	2DPC
		16 Gb (DRAM Density)		1.1 V	
RDIMM	SRx8 (RC D)	16 GB		4800	4400
	SRx4 (RC C)	32 GB			
	SRx4 (RC F) 9x4	32 GB			
	DRx8 (RC E)	32 GB			
	DRx4 (RC A)	64 GB			
	DRx4 (RC B) 9x4	64 GB			
RDIMM 3DS	(4R/8R) x4 (RC A)	2H-128 GB 4H-256 GB			
LRDIMM/LRDIMM-3DS	N/A	N/A		Not Supported	Not Supported

* 1DPC applies to 1 Socket Per Channel (SPC) or 2SPC implementation.

DDR5 Memory Support for the 5th Gen. Intel Xeon Scalable Processors

DDR5 Memory Support for the 5th Gen. Intel Xeon Scalable Processors					
Type	Ranks Per DIMM & Data Width (Stack)	DIMM Capacity (GB)		Speed (MT/s); Voltage (V); DIMM Per Channel (DPC)	
				1DPC ^{Note 1}	2DPC
		16 Gb (DRAM Density)	24 Gb (DRAM Density)	1.1 V	
RDIMM	SRx8 (RC D)	16 GB	24 GB ^{Note 2}	5600	4400
	SRx4 (RC C)	32 GB	48 GB ^{Note 2}		
	SRx4 (RC F) 9x4	32 GB	48 GB ^{Note 2}		
	DRx8 (RC E)	32 GB	48 GB ^{Note 2}		
	DRx4 (RC A)	64 GB	96 GB		
	DRx4 (RC B) 9x4	64 GB	96 GB		
RDIMM 3DS	(4R/8R) x4 (RC A)	2H-128 GB 4H-256 GB	N/A		
LRDIMM/LRDIMM-3DS	N/A	N/A	N/A	Not Supported	Not Supported

Note 1: 1DPC applies to 1 Socket Per Channel (SPC) or 2SPC implementation.
Note 2: The 24 Gb 2DPC configuration with 24 GB and 48 GB DIMMs is NOT recommended.

Memory Population for the X13DEG-R Motherboard (with 32 DIMM Slots)

DDR5 Memory Population Table for the X13DEG-R Motherboard (with 32 DIMM Slots)	
1 CPU:	Memory Population Sequence
1 CPU & 1 DIMM	P1-DIMMA1 or P1-DIMME1 or P1-DIMMB1 or P1-DIMMF1
1 CPU & 2 DIMMs	P1-DIMMA1/P1-DIMMG1 or P1-DIMMC1/P1-DIMME1
1 CPU & 4 DIMMs	P1-DIMMA1/P1-DIMMC1/P1-DIMME1/P1-DIMMG1
1 CPU & 6 DIMM	P1-DIMMA1/P1-DIMMC1/P1-DIMMD1/P1-DIMME1/P1-DIMMF1/P1-DIMMG1 or P1-DIMMA1/P1-DIMMB1/P1-DIMMC1/P1-DIMME1/P1-DIMMG1/P1-DIMMH1 or P1-DIMMB1/P1-DIMMC1/P1-DIMMD1/P1-DIMME1/P1-DIMMF1/P1-DIMMH1 or P1-DIMMA1/P1-DIMMB1/P1-DIMMD1/P1-DIMMF1/P1-DIMMG1/P1-DIMMH1
1 CPU & 8 DIMMs	P1-DIMMA1/P1-DIMMB1/P1-DIMMC1/P1-DIMMD1/P1-DIMME1/P1-DIMMF1/P1-DIMMG1/P1-DIMMH1
1 CPU & 12 DIMMs	P1-DIMMA1/P1-DIMMA2/P1-DIMMB1/P1-DIMMC1/P1-DIMMC2/P1-DIMMD1/P1-DIMME1/P1-DIMME2/P1-DIMMF1/P1-DIMMG1/P1-DIMMG2/P1-DIMMH1 or P1-DIMMA1/P1-DIMMB1/P1-DIMMB2/P1-DIMMC1/P1-DIMMD1/P1-DIMMD2/P1-DIMME1/P1-DIMMF1/P1-DIMMF2/P1-DIMMG1/P1-DIMMH1/P1-DIMMH2
1 CPU & 16 DIMMs	P1-DIMMA1/P1-DIMMA2/P1-DIMMB1/P1-DIMMB2/P1-DIMMC1/P1-DIMMC2/P1-DIMMD1/P1-DIMMD2/P1-DIMME1/P1-DIMME2/P1-DIMMF1/P1-DIMMF2/P1-DIMMG1/P1-DIMMG2/P1-DIMMH1/P1-DIMMH2
2 CPUs: (Recommended)	Memory Population Sequence
2 CPUs & 2 DIMMs	CPU1: P1-DIMMA1, CPU2: P2-DIMMA1 or CPU1: P1-DIMME1, CPU2: P2-DIMME1 or CPU1: P1-DIMMB1, CPU2: P2-DIMMB1 or CPU1: P1-DIMMF1, CPU2: P2-DIMMF1
2 CPUs & 4 DIMMs	CPU1: P1-DIMMA1/P1-DIMMG1, CPU2: P2-DIMMA1/P2-DIMMG1 or CPU1: P1-DIMMC1/P1-DIMME1, CPU2: P2-DIMMC1/P2-DIMME1
2 CPUs & 8 DIMMs	CPU1: P1-DIMMA1/P1-DIMMC1/P1-DIMME1/P1-DIMMG1 CPU2: P2-DIMMA1/P2-DIMMC1/P2-DIMME1/P2-DIMMG1
2 CPUs & 10 DIMMs	CPU1: P1-DIMMA1/P1-DIMMC1/P1-DIMMD1/P1-DIMME1/P1-DIMMF1/P1-DIMMG1 CPU2: P2-DIMMA1/P2-DIMMC1/P2-DIMME1/P2-DIMMG1
2 CPUs & 12 DIMMs	CPU1: P1-DIMMA1/P1-DIMMC1/P1-DIMMD1/P1-DIMME1/P1-DIMMF1/P1-DIMMG1 CPU2: P2-DIMMA1/P2-DIMMC1/P2-DIMMD1/P2-DIMME1/P2-DIMMF1/P2-DIMMG1 or CPU1: P1-DIMMA1/P1-DIMMB1/P1-DIMMC1/P1-DIMME1/P1-DIMMG1/P1-DIMMH1 CPU2: P2-DIMMA1/P2-DIMMB1/P2-DIMMC1/P2-DIMME1/P2-DIMMG1/P2-DIMMH1 or CPU1: P1-DIMMB1/P1-DIMMC1/P1-DIMMD1/P1-DIMME1/P1-DIMMF1/P1-DIMMH1 CPU2: P2-DIMMB1/P2-DIMMC1/P2-DIMMD1/P2-DIMME1/P2-DIMMF1/P2-DIMMH1 or CPU1: P1-DIMMA1/P1-DIMMB1/P1-DIMMD1/P1-DIMMF1/P1-DIMMG1/P1-DIMMH1 CPU2: P2-DIMMA1/P2-DIMMB1/P2-DIMMD1/P2-DIMMF1/P2-DIMMG1/P2-DIMMH1
2 CPUs & 16 DIMMs	CPU1: P1-DIMMA1/P1-DIMMB1/P1-DIMMC1/P1-DIMMD1/P1-DIMME1/P1-DIMMF1/P1-DIMMG1/P1-DIMMH1 CPU2: P2-DIMMA1/P2-DIMMB1/P2-DIMMC1/P2-DIMMD1/P2-DIMME1/P2-DIMMF1/P2-DIMMG1/P2-DIMMH1
2 CPUs & 22 DIMMs	CPU1: P1-DIMMA1/P1-DIMMA2/P1-DIMMB1/P1-DIMMB2/P1-DIMMC1/P1-DIMMC2/P1-DIMMD1/P1-DIMMD2/P1-DIMME1/P1-DIMME2/P1-DIMMF1/P1-DIMMF2/P1-DIMMG1/P1-DIMMG2/P1-DIMMH1/P1-DIMMH2 CPU2: P2-DIMMA1/P2-DIMMC1/P2-DIMMD1/P2-DIMME1/P2-DIMMF1/P2-DIMMG1
2 CPUs & 24 DIMMs	CPU1: P1-DIMMA1/P1-DIMMA2/P1-DIMMB1/P1-DIMMB2/P1-DIMMC1/P1-DIMMC2/P1-DIMMD1/P1-DIMMD2/P1-DIMME1/P1-DIMME2/P1-DIMMF1/P1-DIMMF2/P1-DIMMG1/P1-DIMMG2/P1-DIMMH1/P1-DIMMH2 CPU2: P2-DIMMA1/P2-DIMMB1/P2-DIMMC1/P2-DIMMD1/P2-DIMME1/P2-DIMMF1/P2-DIMMG1/P2-DIMMH1
2 CPUs & 32 DIMMs	CPU1: P1-DIMMA1/P1-DIMMA2/P1-DIMMB1/P1-DIMMB2/P1-DIMMC1/P1-DIMMC2/P1-DIMMD1/P1-DIMMD2/P1-DIMME1/P1-DIMME2/P1-DIMMF1/P1-DIMMF2/P1-DIMMG1/P1-DIMMG2/P1-DIMMH1/P1-DIMMH2 CPU2: P2-DIMMA1/P2-DIMMA2/P2-DIMMB1/P2-DIMMB2/P2-DIMMC1/P2-DIMMC2/P2-DIMMD1/P2-DIMMD2/P2-DIMME1/P2-DIMME2/P2-DIMMF1/P2-DIMMF2/P2-DIMMG1/P2-DIMMG2/P2-DIMMH1/P2-DIMMH2

Note: The memory configuration is recommended by Supermicro for optimal memory performance. Please use this configuration to maximize your memory performance.

DDR5 Memory Population Table for the X13DEG-R Motherboard (with the Intel Xeon Max Series and 16 DIMM Slots)									Intel Xeon Max Series Partitioning Modes					
	P1/P2- DIMMH1	P1/P2- DIMMG1	P1/P2- DIMMF1	P1/P2- DIMME1	P1/P2- DIMMA1	P1/P2- DIMMB1	P1/P2- DIMMC1	P1/P2- DIMMD1	SNC2	SNC4 (DDR+ HBM)	Hemi (DDR only)	Quad (HBM)	Quad (DDR)	All2All (DDR only)
Xeon Max Only										V		V		
Xeon Max & 1 DIMM					DDR5							V		V
Xeon Max & 1 DIMM				DDR5								V		V
Xeon Max & 2 DIMMs		DDR5			DDR5							V		V
Xeon Max & 2 DIMMs				DDR5			DDR5					V		V
Xeon Max & 4 DIMMs		DDR5		DDR5	DDR5		DDR5			V		V	V	
Xeon Max & 8 DIMMs	DDR5	DDR5	DDR5	DDR5	DDR5	DDR5	DDR5	DDR5		V		V	V	

* SNC: Sub NUMA Cluster

Notes: For the memory support on the Intel Xeon Max Series, which is with the high bandwidth memory (HBM), please note the following:

1. CPU Only Mode: This mode is supported when the Intel Xeon Max Series is installed with no DDR memory module. The feature of "Total Memory" on the Main screen of the BIOS Setup utility displays the HBM size.
2. Cache Mode: This mode is supported when the Intel Xeon Max Series is installed with the DDR memory module(s). The processor will be configured in the Two-Level Memory mode (2LM), which is the default setting. The feature of "Total Memory" on the Main screen of the BIOS Setup utility displays the size of DDR memory module(s) installed in your system.
3. Flat Mode: This mode supports the One-Level Memory mode (1LM). Please go to the BIOS Setup utility (Advanced > Chipset Configuration > North Bridge > Memory Configuration) to set "Volatile Memory Mode" to 1LM. The feature of "Total Memory" on the Main screen of the BIOS Setup utility displays the result of adding the HBM size to the DDR size.
4. The total DDR size must be at least two times of the HBM size for each CPU socket.

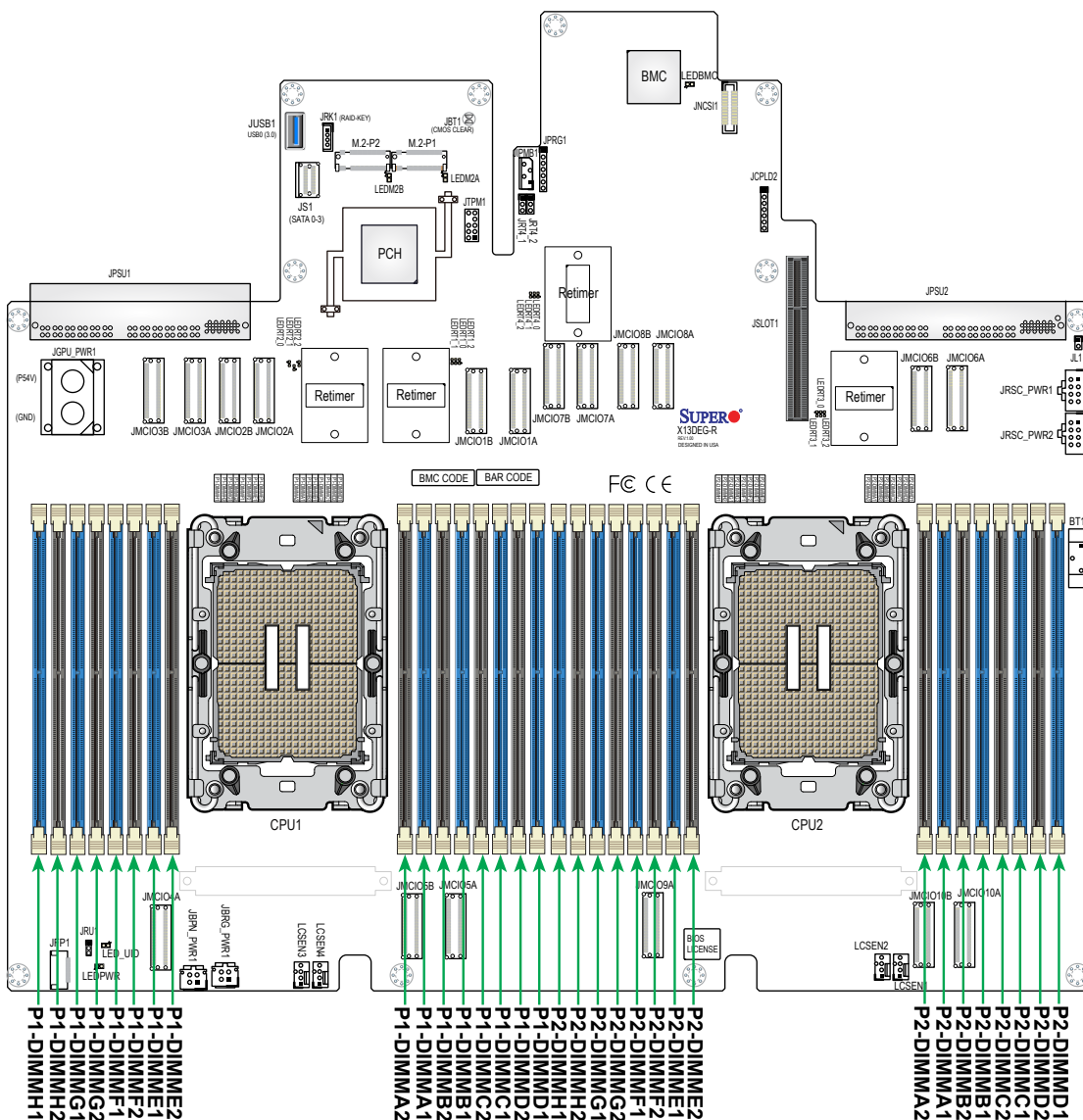

Figure 3-2. DIMM Numbering

Note: All P1 slots are supported by CPU1 and all P2 slots are supported by CPU2.

DIMM Installation

Important: Do not use excessive force when pressing the release tabs on the ends of the DIMM socket to avoid causing any damage to the memory module or the DIMM socket. Handle memory modules with care. Carefully follow all the instructions given in ["Static Sensitive Devices"](#) to avoid ESD-related damages done to your memory modules or components.

Note: The DDR5 DIMM modules are **NOT** hot-swappable so be sure to disconnect power for a minimum of 20 seconds before inserting or removing them.

1. Insert the desired number of DIMMs into the memory slots based on the recommended DIMM population tables in the previous section. Locate DIMM memory slots on the motherboard as shown on the right.

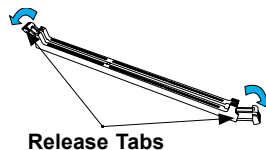

2. Push the release tabs outwards on both ends of the DIMM slot to unlock it.

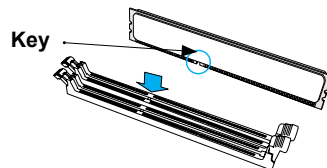

3. Align the key of the memory module with the DIMM socket key on the memory slot.

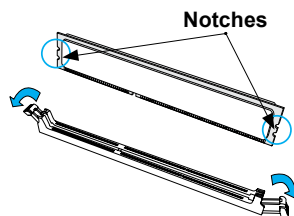

4. Align the notches on both ends of the module against the latches on the ends of the slot.
5. Push both ends of the module straight down into the slot until the module snaps into place.
6. Press the release tabs to the lock positions to secure the memory module into the slot.

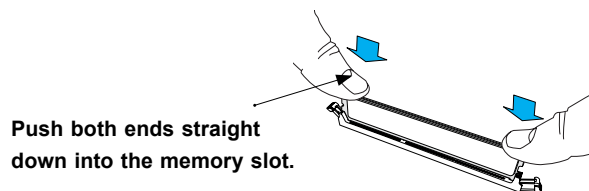

DIMM Removal

Press both release tabs on the ends of the memory module to unlock it. Once the memory module has been loosened, remove it from the memory slot.

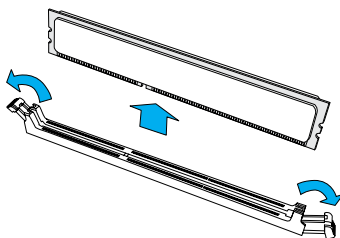

3.5 Motherboard Battery

The motherboard uses non-volatile memory to retain system information when system power is removed. This memory is powered by a lithium battery residing on the motherboard.

Battery Removal

To remove the onboard battery, follow the steps below:

1. Power off your system and unplug your power cable.
2. Locate the onboard battery as shown below.
3. Using a tool such as a pen or a small screwdriver, push the battery lock outwards to unlock it. Once unlocked, the battery will pop out from the holder.
4. Remove the battery.

Proper Battery Disposal

Important: Handle used batteries carefully. Do not damage the battery in any way; a damaged battery may release hazardous materials into the environment. Do not discard a used battery in the garbage or a public landfill. Please comply with the regulations set up by your local hazardous waste management agency to dispose of your used battery properly.

Battery Installation

To install an onboard battery, follow steps 1 and 2 above and continue below:

Important: When replacing a battery, be sure to only replace it with the same type.

1. Identify the battery's polarity. The positive (+) side should be facing up.
2. Insert the battery into the battery holder and push it down until you hear a click to ensure that the battery is securely locked.

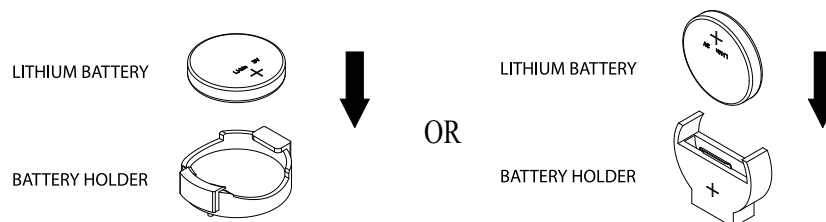

Figure 3-3. Installing the Onboard Battery

3.6 M.2 SSDs

The X13DEG-R motherboard has two PCIe 3.0 M.2 slots (M.2-P1, M.2-P2).

Installing M.2 Drives

1. Remove power from the system and then remove the top cover as described in Sections 3.1 and 3.2.
2. Refer to its layout image in the [Motherboard manual](#) and locate the M.2 slot. Insert the plastic clip into the hole against the M.2 slot on the motherboard.
3. Turn the plastic clip by 90° degrees.
4. Insert the M.2 sideways into the connector so that it lays flat, then secure it to the motherboard with the plastic clip.
5. Repeat as necessary for more M.2 drives.
6. Finish by replacing the cover and restoring power to the system.

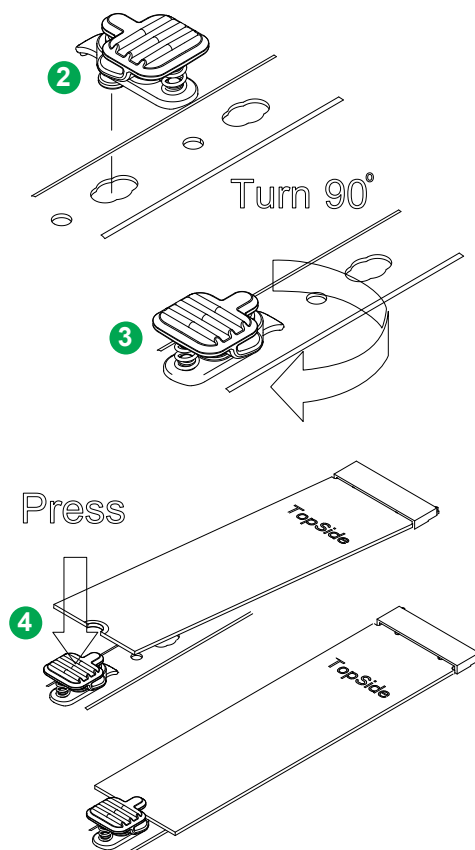

Figure 3-4. Installing an M.2 SSD

3.7 Storage Drives

The CSE-228G2TS-R5K25P chassis supports up to four 2.5" storage drives in drive carriers to simplify their removal from the chassis. These carriers also help promote proper airflow. Note that only SSDs are supported, spindle-type HDDs are not.

All four drive carriers reside in a storage module that has Slim-SAS connectors at the rear where the data cables attach to the motherboard. A rear power connector is also used to provide input power to the module backplane from the motherboard.

Drive Carriers

Each drive carrier has two LED indicators: an activity indicator and a status indicator. For RAID configurations using a controller, the meaning of the status indicator is described in the table below. For OS RAID or non-RAID configurations, some LED indications are not supported, such as hot spare.

Drive Carrier LED Indicator			
	Color	Blinking Pattern	Behavior for Device
Activity LED	Blue	Solid On	SAS/NVMe drive installed
	Blue	Blinking	I/O activity
Status LED	Red	Solid On	Failure of drive with RSTe support
	Red	Blinking at 1 Hz	Rebuild drive with RSTe support
	Red	Blinking with two blinks and one stop at 1 Hz	Hot spare for drive with RSTe support (not supported in VMD mode)
	Red	On for five seconds, then off	Power on for drive with RSTe support
	Red	Blinking at 4 Hz	Identify drive with RSTe support

Note: Enterprise level drives are recommended for use in Supermicro chassis and servers. For information on recommended drives, see the Supermicro website, <http://www.supermicro.com/products/info/files/storage/SBB-HDDCompList.pdf>.

Removing Drive Carriers

Important: Except for short periods of time (swapping drives), do not operate the server with the drive carriers removed from the bays, regardless of how many drives are installed. This is to ensure proper airflow.

Removing Drive Carriers from the Chassis

1. Push the release button on the drive carrier. This releases and extends the drive carrier handle. If the release button does not release it, the handle may be locked: use a flat-head screwdriver to unlock the release.
2. Use the handle to pull the carrier out of the chassis as shown below.

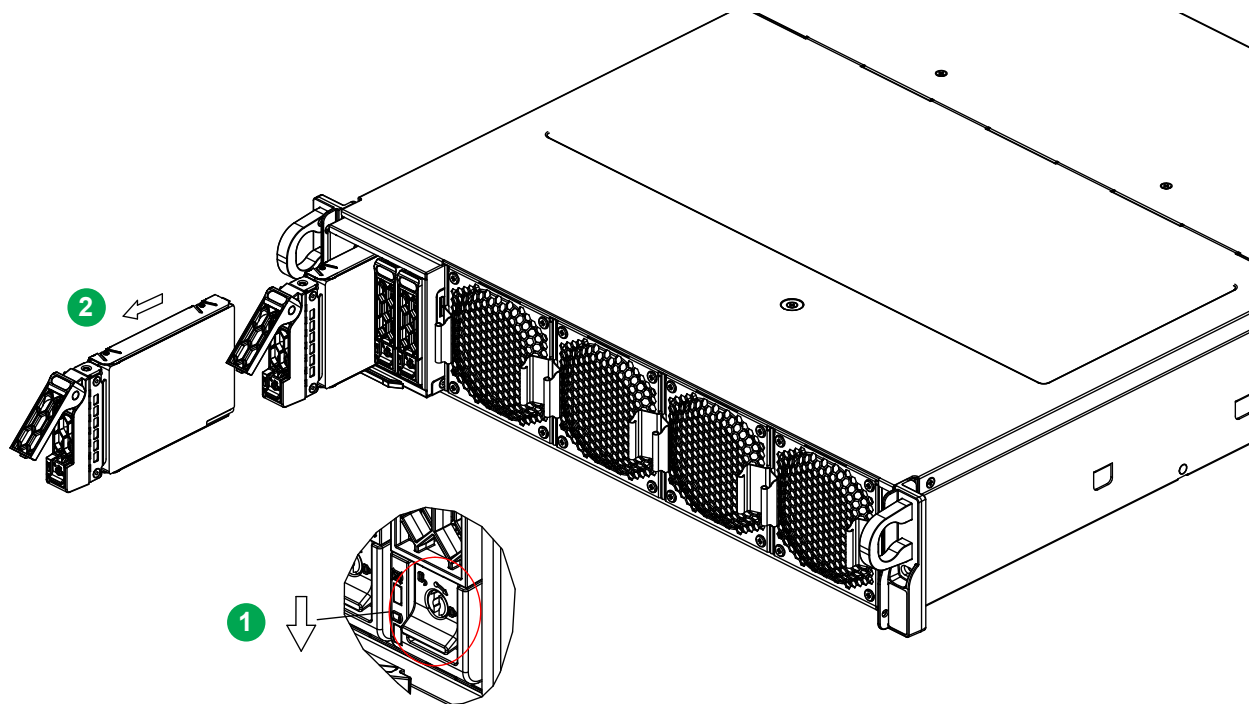

Figure 3-5. Removing a Drive Carrier

Installing 2.5" SSDs

Installing a 2.5" SSD

1. Place the hard drive carrier on a flat surface.
2. Orient the drive with the connector facing the bottom rear of the carrier. The drive can be inserted from above into the clips until a "click" is heard.
3. Use the open handle of the drive carrier to insert the carrier into the open drive bay.
4. Secure the drive carrier into the drive bay by closing the drive carrier handle.

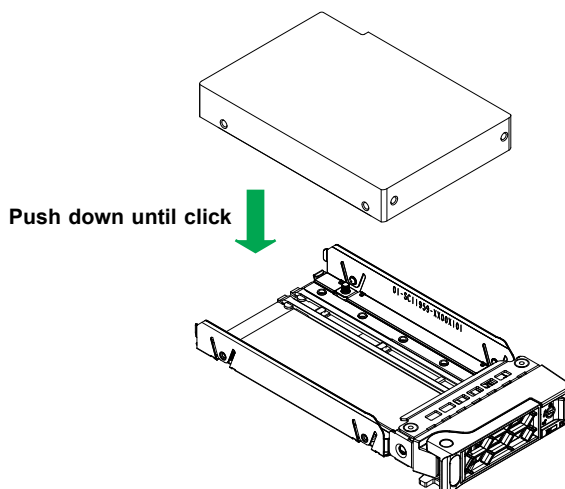

Figure 3-6. Installing a 2.5" SSD

Removing a 2.5" SSD

1. After removing the carrier from the system, push up from the bottom of the drive to remove it from the carrier.
2. Replace with a new drive and insert the carrier back into the open drive bay.

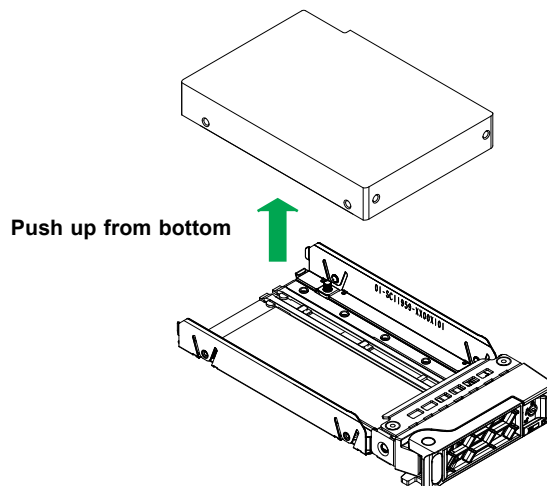

Figure 3-7. Removing a 2.5" SSD

3.8 Expansion Cards

The SYS-221GE-TNHT-LC1 includes two riser cards to support the use of expansion (add-on) cards.

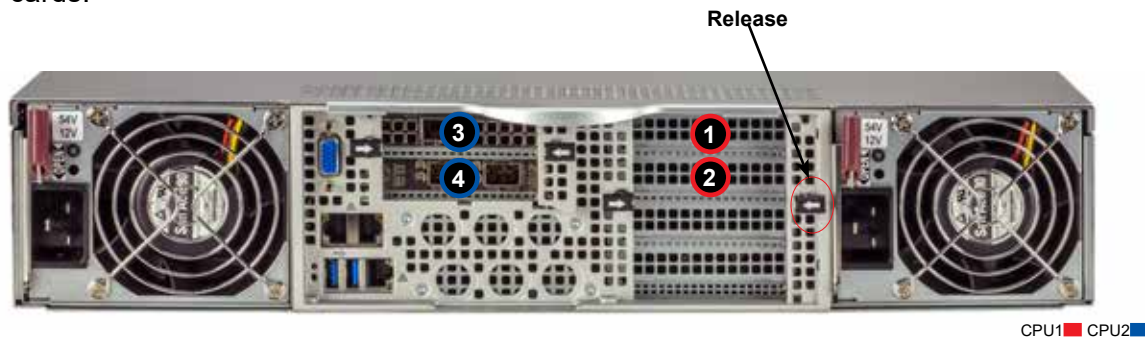

Figure 3-8. Expansion Card Chassis Slots

Riser Cards

This system includes two riser cards that provides PCIe capabilities.

Expansion Slot Locations		
Slot Location (# above)	Riser Card	Description (all PCIe 5.0)
Slots 1-2	RSC-G-66G5+ #1	x16 FH, 2.5"L (CPU1)
Slots 3-4	RSC-G-66G5+ #2	x16 FH, 2.5"L (CPU2)

Full-height = 4.2", Low-profile = 2.5", Full-length = 10.5", Half-length = 6.6"

Installing Expansion Cards

The system supports four low-profile PCIe Gen 5 x16 slots. Expansion cards are recommended to be serviced by Supermicro due to the optimized density of the 2U form factor.

Important: Due to the weight of the system, this should not be attempted in the rack. The system needs to be placed on a flat ESD-safe surface with ample support.

Installing an Expansion Card

1. Power down the system, remove power cables and wait 30 seconds then remove the top cover.
2. Begin by removing the riser assemblies.
3. At the rear of the chassis, remove the PCI riser by unlatching the riser release (see Figure 3-8 for locations). There are two releases at the rear and one at the crossbar.
4. Once the riser releases are extended to the open position, lift the riser assembly vertically. Be careful not to damage the power or data cables attached to the assemblies. If more room is needed the cables can be detached, however, it is important to note the cable numbers and their mated connectors. Please see the cable mapping guide in Chapter 1.
5. Install and secure the expansion cards into the PCI riser.
6. Return and lock the PCI riser back into the back of the chassis and lock the two releases at the rear and one at the crossbar.

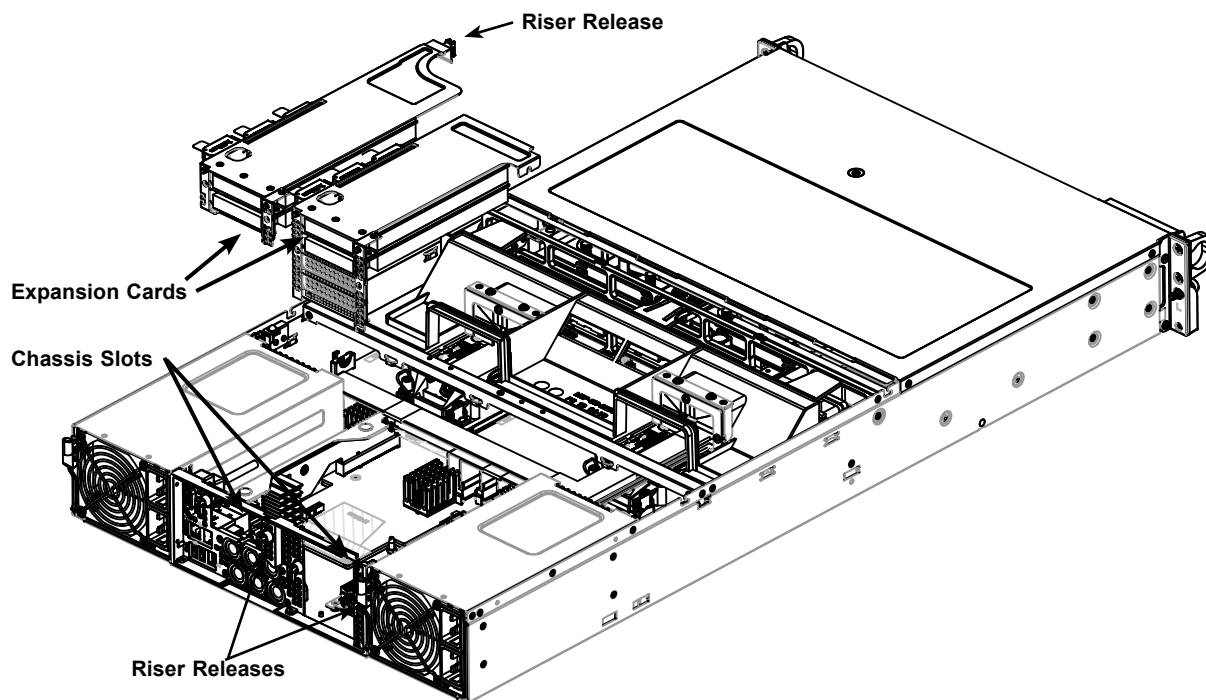

Figure 3-9. Installing Expansion Cards

3.9 Graphics Processing Units

Individual GPU and GPU baseboards are recommended to be serviced by Supermicro due to the optimized density of the 2U form factor.

Prior to submitting an RMA for GPUs, Nvidia requires that their Field Diagnostic tool is first run to isolate hardware failures and obtain a log file for review. Check with Supermicro Technical Services for more details. In addition, more details can be found in Nvidia reference document Baseboard Field Diagnostics Software Guide DU-09163-001.

Replacing GPU Baseboard Module

1. Run Nvidia's Field Diagnostic tool to isolate failures and obtain a log file for review.
2. Remove the GPU cold plate on the GPU baseboard so that it is lighter and easier to handle.
3. Disconnect the GPU baseboard module's 54 V power cable by extending the red colored finger release of the Radsok/Surlok cable (cable #27 as illustrated in Chapter 1) and pulling up. Use a small plastic tool or Velcro loop to gain access to the finger release if needed.
4. Unscrew the GPU baseboard latch and T-handle screws using a T10 torx head driver
5. Release the "bail latch", which will separate the GPU baseboard from the PCIe transition board assembly. The baseboard should then be loose.
6. Hold the "T" handle with one hand while lifting the bail latch at the other end of the baseboard.
7. Lift the GPU baseboard vertically and at a slight angle to remove the GPU baseboard. Be careful not to scratch the GPU baseboard or your hands on the chassis metal edges.

For installation reverse the above steps.

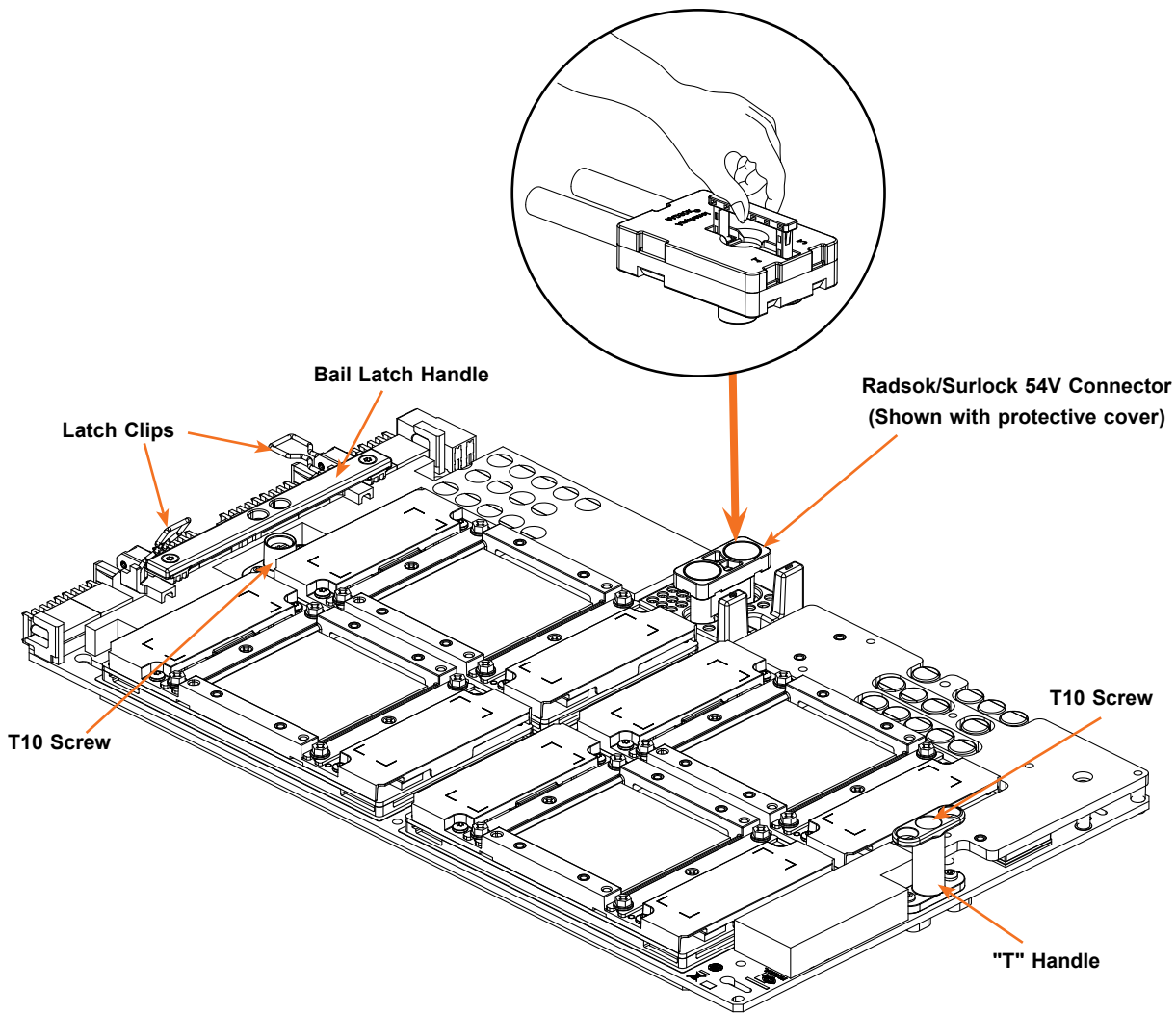

Figure 3-10. Replacing GPU Baseboard Module

Replacing Individual GPUs

Prior to submitting an RMA for GPUs, Nvidia requires that their Field Diagnostic tool is first run to isolate hardware failures and obtain a log file for review. Check with Supermicro Technical Services for more details. In addition, more details can be found in Nvidia reference document Baseboard Field Diagnostics Software Guide DU-09163-001. Use these tools to determine the failed GPU and locate using the Cable Mapping Guide Figure and GPU Mapping Table. Be sure to identify the failed GPU correctly and if any questions reach out to Supermicro Technical Service team to help.

Note: GPU cold plate and individual GPU SXM5 replacement is recommended to be done by a qualified Supermicro service technician. Always ensure that new cold plates are used. Qualified cold plates include thermal interface material (TIM) with specified dimension and thickness.

1. Prior to assembly, ensure the GPU devices have no thermal material or grease. Also check that the cold plates are new and have unused thermal interface material (TIM) present.
2. Gently place the GPU cold plate over the GPU baseboard's SXM5 socket while keeping the GPU cold plate steady and level.
3. Line up the screws to the socket screw holes underneath.
4. Use a Philips-head screwdriver to screw down screws in this order: 1,2,3,4. Ensure a torque force between 3 to 4 lbf-in is used. The use of a torque screwdriver with torque setting feature is recommended.
5. To remove the individual GPU SXM5 module, please follow "Nvidia H100 SXM5/GPU Module: Removal and Installation Instruction" in Nvidia document #1055915.

For installation reverse the above steps.

Note: Immediately after installing or before removing the GPU cold plate, heat it to 60 °C for an hour.

3.10 System Cooling

System Fans

Four hot-swap fans provide cooling. They can be replaced without powering down the system. However, failed fans should be replaced quickly to maintain proper system airflow.

Fan speed is controlled by a system temperature setting in the BMC interface. If a fan fails, the remaining fans will ramp up to full speed. The system can continue to run with a failed fan. Replace any failed fan at your earliest convenience with the same type and model.

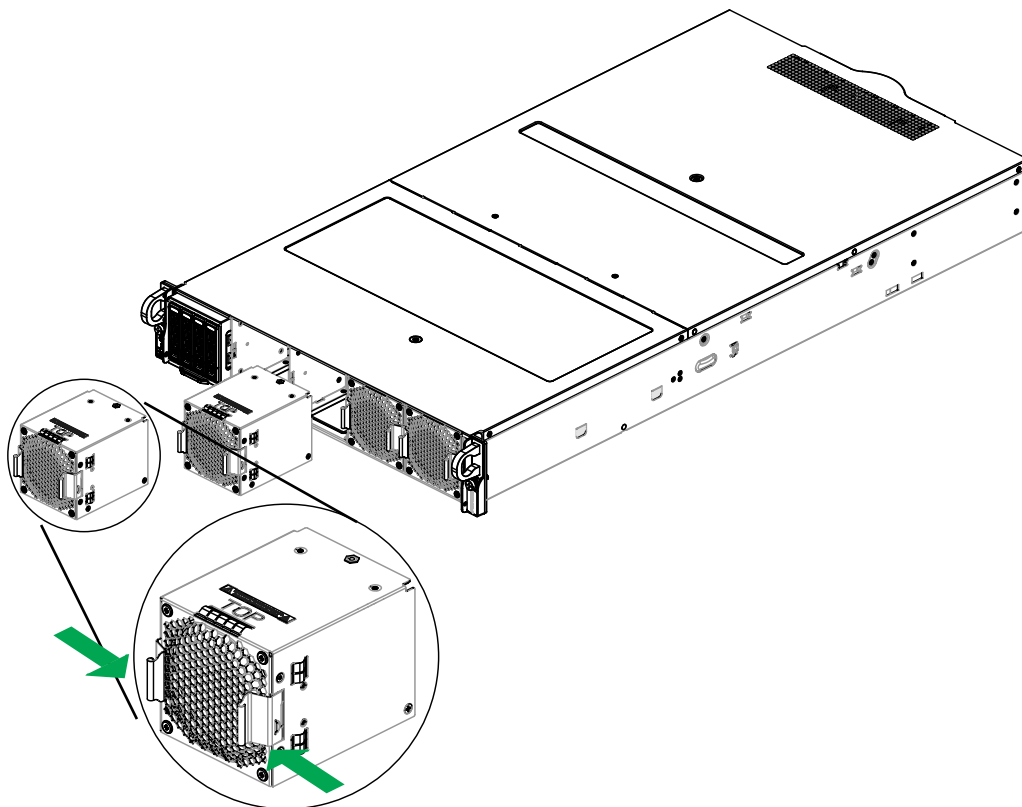

Figure 3-11. Removing System Fans

Note: For system fan operation the following hardware is required: GPU baseboard module, PCIe transition board, fan board, motherboard, PSUs, and cabling.

Changing a System Fan

1. Determine which fan is failing. If possible, use the BMC interface. If not, while the power is on, examine the fans to determine which one has failed.
2. Remove the failed fan from the chassis by squeezing together the two tabs on either side then pulling it out from the chassis.

3. Replace the fan with a new one, making sure it is within specifications.
4. Push the fan into the housing until it is secure and running.
5. Confirm that the fan is working properly.
6. Check the routing of the cables.

Air Shroud

The SYS-221GE-TNHT-LC1 is a complete system and does not require air shroud installation. However, in case air shrouds need to be installed, follow the procedure below.

Installing the Air Shrouds

1. Remove power from the system.
2. Remove the system from the rack, place it on a stable surface, and remove the top cover.
3. Ensure the CPU, CPU cold plates, and configured DIMMs are installed
4. Gently place the air shroud over the CPU cold plate with the front snap locations lining up with metal chassis middle crossbar. Be careful that the air shroud legs at either end do not interfere with any motherboard components such as DIMMs. Guide the air shroud around cable bundles as necessary.
5. Replace the cover, place back in the rack, and power on the system.

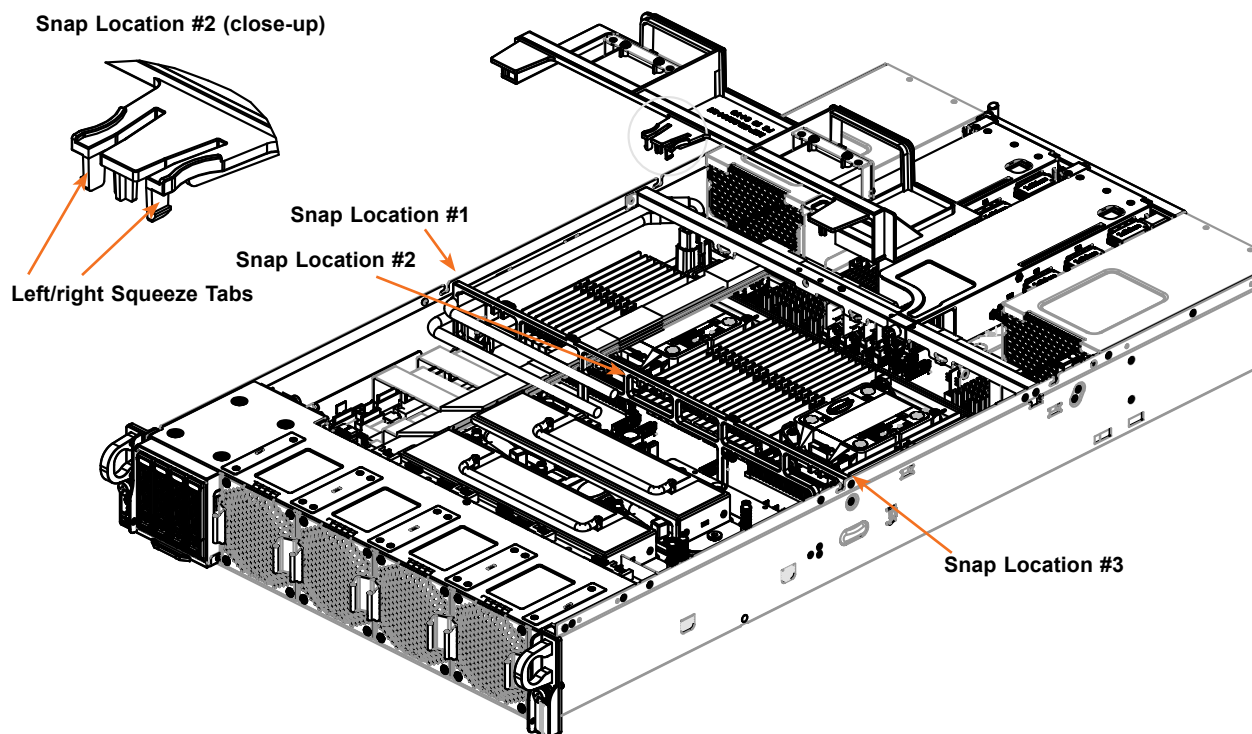

Figure 3-12. Installing the Air Shrouds

Checking the Server Air Flow

- Make sure there are no objects to obstruct airflow in and out of the server.
- If you are using a front bezel, make sure the bezel filter is replaced periodically.
- Do not operate the server without drives or drive trays in the drive bays.
- Use only recommended server parts.
- Make sure no wires or foreign objects obstruct air flow through the chassis. Pull all excess cabling out of the airflow path or use shorter cables.

The control panel LEDs display system heat status. See “Control Panel” in Chapter 1 for details.

Overheating

There are several possible responses if the system overheats.

Overheat Temperature Setting

Some backplanes allow the overheat temperature to be set at 45, 50, or 55 by changing a jumper setting. For more information, consult the backplane user manual at www.supermicro.com. (Click Support, then the Manuals link.)

Responses

If the server overheats:

1. Use the LEDs to determine the nature of the overheating condition.
2. Confirm that the chassis covers are installed properly.
3. Make sure all fans are present and operating normally.

3.11 Power Supply

The chassis features dual or fully redundant power supplies. In redundant mode, single power modules can be changed without powering down the system. New units can be ordered directly from Supermicro or authorized distributors.

These power supplies are auto-switching capable. This feature enables them to automatically sense the input voltage and operate at a 100-120 V or 180-240 V (For high-power or fully configured systems 180-240 V service is required). An amber light will be illuminated on the power supply when the power is off. An illuminated green light indicates that the power supply is operating.

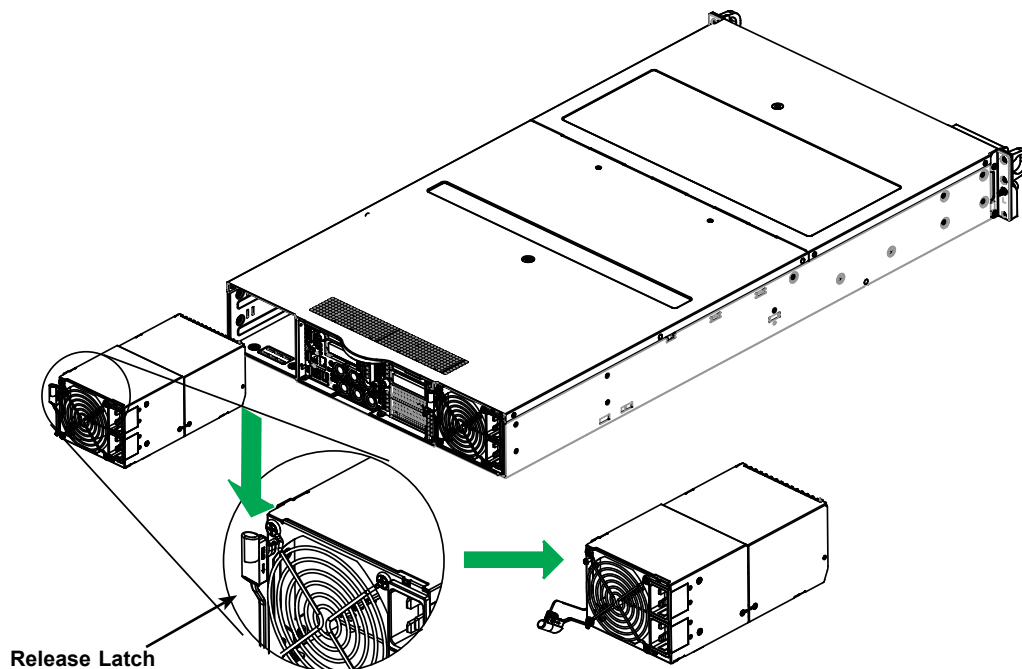

Figure 3-13. Removing the Power Supply

Replacing the Power Supply

1. Unplug the AC cord from the module to be replaced.
2. Push the release latch on the back of the power supply down (see above figure).
3. Pull the power supply out using the latch once released.
4. Replace the failed power module with the same model.
5. Push the new power supply module into the power bay until it clicks.
6. Plug the AC power cord back into the module.

Power Supply Indicators		
Power Supply Condition	Green LED	Amber LED
No AC Power to Power Supply	OFF	OFF
Power Supply critical events causing a shutdown/ failure/ OCP/ OVP/ Fan Fail/ OTP/ UVP	OFF	ON
Power Supply Warning Events Where the power supply continues to operate; High temperature; Over voltage; under voltage, etc.	OFF	1 Hz Blinking
AC present only 12VSB ON (PS OFF)	1 Hz Blinking	OFF
Output ON and OK	ON	OFF
AC cord unplugged and in redundant mode	OFF	ON

Chapter 4

Motherboard Connections

This section describes the connections on the motherboard and provides pinout definitions. Note that depending on how the system is configured, not all connections are required. The LEDs on the motherboard are also described here. A motherboard layout indicating component locations may be found in [Chapter 1](#). More detail can be found in the [Motherboard Manual](#).

Please review the Safety Precautions in [Appendix A](#) before installing or removing components.

4.1 Power Connections

Power Connectors

Two power supply connectors, located at JPSU1/JPSU2 (5.25 KW), provide main power to your system. Also, connect the power connector (JGPU_PWR1) to your GPU module. The two 8-pin power connectors (JRSC_PWR1, JRSC_PWR2) are for the riser cards. One 4-pin power connector (JBPN_PWR1) is for the storage backplane. The other 4-pin power connector (JBRG_PWR1) is for the GPU transition board. All these power connectors meet the ATX SSI EPS 12 V specification and must be connected to your power supply and the corresponding devices to provide adequate power to your system.

GPU Power (JGPU_PWR1) Pin Definitions	
Pin#	Definition
1	54 V
2	Ground

12 V 8-pin Riser Card Power (JRSC_PWR1, JRSC_PWR2) Pin Definitions	
Pin#	Definition
1 - 4	Ground
5 - 6	+12 V
7	+3.3 V
8	+3.3 V_STBY

4-pin Storage Backplane Power (JBPN_PWR1) Pin Definitions	
Pin#	Definition
1 - 2	Ground
3	+12 V
4	+12 V

4-pin GPU Transition Board Power (JBRG_PWR1) Pin Definitions	
Pin#	Definition
1 - 2	Ground
3 - 4	+12 V_AUX

4.2 Headers and Connectors

4-pin BMC External I²C Header

A System Management Bus header for the BMC is located at JIPMB1. Connect the appropriate cable here to use the IPMB I²C connection on your system. Refer to the layout for the location of JIPMB1.

Chassis Intrusion

A Chassis Intrusion header is located at JL1 on the motherboard. Attach the appropriate cable from the chassis to inform you when the chassis is opened. Refer to the table below for pin definitions.

Chassis Intrusion Pin Definitions	
Pin#	Definition
1	Intrusion Input
2	Ground

MCIO Connectors for GPU Transition Board

The motherboard supports eight PCIe 5.0 x8 MCIO connectors (JMCI01A/1B, JMCI02A/2B, JMCI06A/6B, JMCI07A/7B) to be connected to the GPU transition board for your system. Four retimers are also supported for these eight MCIO connectors.

MCIO Connectors for Riser Cards

The motherboard supports eight PCIe 5.0 x8 MCIO connectors (JMCI03A/3B, JMCI05A/5B, JMCI08A/8B, JMCI010A/10B) to be connected to the riser cards for your system.

MCIO Connectors for Storage Devices

The motherboard supports two PCIe 5.0 x8 MCIO connectors (JMCI04A, JMCI09A) to be connected to the storage devices for your system.

NC-SI Connector

The Network Controller Sideband Interface (NC-SI) connector is located at JNCSI1. This connector is used to connect a Network Interface Card (NIC) to the motherboard to allow the onboard BMC to communicate with a network.

TPM/Port 80 Header

The JTPM1 header is used to connect a Trusted Platform Module (TPM)/Port 80, which is available from Supermicro (optional). A TPM/Port 80 connector is a security device that supports encryption and authentication in hard drives. It allows the motherboard to deny access if the TPM, which is associated with the hard drive, is not installed in the system. See the layout below for the location of the TPM header. Please go to the following link for more information on the TPM: https://www.supermicro.com/manuals/other/AOM-TPM-9670V_9670H.pdf.

Trusted Platform Module Header Pin Definitions			
Pin#	Definition	Pin#	Definition
1	+3.3 V	2	SPI_CS#
3	RESET#	4	SPI_MISO
5	SPI_CLK	6	GND
7	SPI_MOSI	8	NC
9	+3.3 V Stdby	10	SPI_IRQ#

SATA 3.0 Connections

The motherboard has one SATA 3.0 connector (JS1), which supports four SATA connections (SATA 0-3). These SATA connections are supported by the Intel C741 chipset. Connecting a proper SATA cable to JS1 for SATA 3.0 connections.

Leakage Sensor Board Connectors

The motherboard supports four Leakage Sensor Board connectors (LCSEN1 – LCSEN4), which can be connected to the Leakage Sensor Boards. The leakage status of the liquid-cooling system is monitored by the BMC.

M.2 Slots (for NVMe Devices Only)

Two M.2 slots are located at M.2-P1 and M.2-P2 on the motherboard. These M.2 slots support PCIe 3.0 x4 M.2 NVMe devices in the 2280 and 22110 form factors. M.2 allows for a variety of card sizes, increased functionality, and spatial efficiency.

VROC RAID Key Header

An Intel VROC RAID Key header is located at JRK1 on the motherboard. Install a VROC RAID Key on JRK1 for NVMe RAID support as shown in the illustration below. Please refer to the layout below for the location of JRK1.

Note: For detailed instructions on how to configure VROC RAID settings, please refer to the VROC RAID Configuration User's Guide posted on the web page under the link: <https://www.supermicro.com/support/manuals/>.

Intel VROC Key Pin Definitions	
Pin#	Definition
1	Ground
2	3.3 V Standby
3	Ground
4	PCH RAID Key

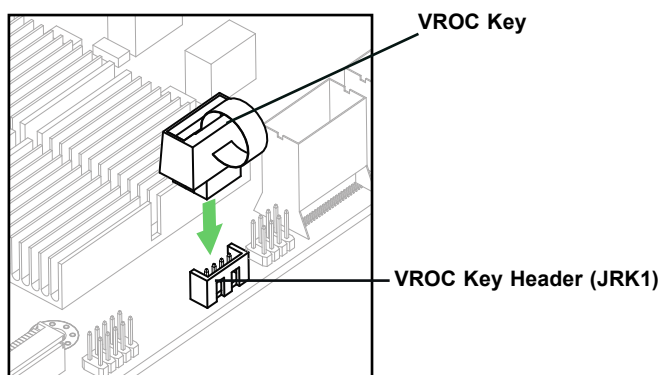

Front Control Panel

The front control panel header (JFP1) contains header pins for various buttons and LED indications with I²C support for front access. This front control panel header is designed specifically for use with Supermicro chassis. Refer to the figure below for the pin-out descriptions for JFP1.

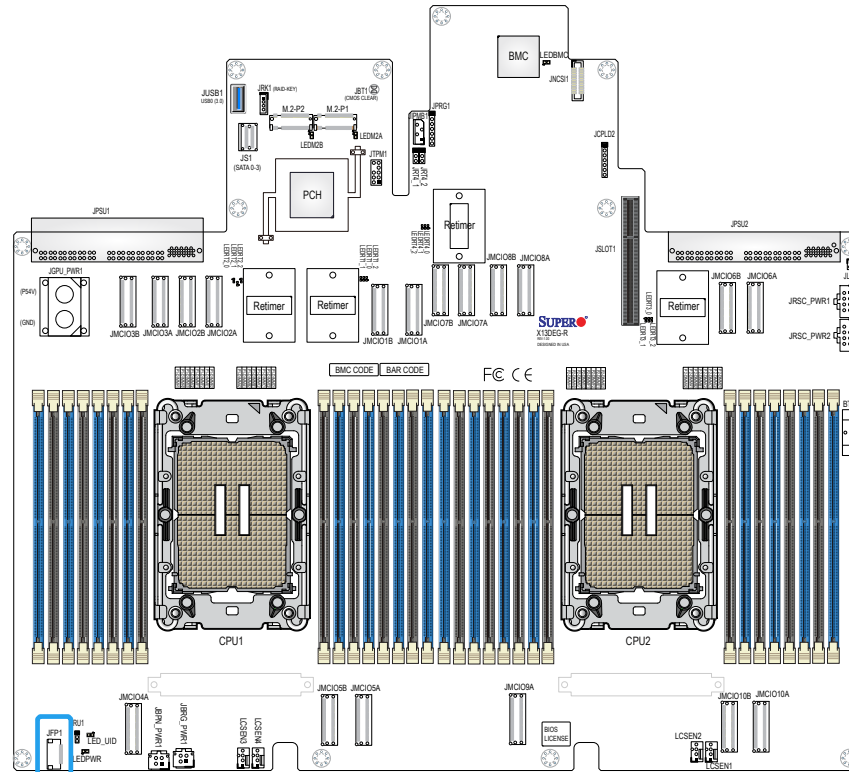

JFP1

1	○ Power Button
2	○ Reset/UID Button
3	○ UID LED_N
4	○ Fail LED_N (OH/FF/PF)
5	○ LAN-2 Activity LED
6	○ LAN-1 Activity LED (Aggregate all LAN)
7	○ HDD Activity LED
8	○ Standby LED_N
9	○ Power/RoT LED_N
10	○ P3V3_STBY
11	○ Ground
12	○ I2C Data
13	○ I2C Clock
14	○ Ground
15	○ Power Fail LED_P
16	
17	
18	
19	○ Power Fail LED_N
20	○ Ground

Figure 4-1. Control Panel Pins

Power On and BMC/BIOS Status LED Button

The Power On and BMC/BIOS Status LED button is located on pin 1 of JFP1.

Power Button LED States	
Status	Event
Green: solid on	System power on
BMC/BIOS blinking green at 4 Hz	BMC/BIOS checking
BIOS blinking green at 4 Hz	BIOS recovery/update in progress
BMC blinking green x2 (2 blinks green) at 4 Hz, 1 pause at 2 Hz (on-on-off-off)	BMC recovery/update in progress
BMC/BIOS blinking green at 1 Hz	Flash not detected or golden image checking failure

Reset Button/UID Button

The UID function is located on pin 2 of JFP1. The UID function is found in the front panel of the chassis. Setting JRU1 to pin 1-2 will configure the UID function in the front panel as a reset button.

UID LED

The unit identifier LED connection is located on pin 3 of JFP1.

Information LED (OH/FF/PF)

The Information LED (OH/Fan Fail/PWR Fail LED) connection is located on pin 4 of JFP1. The LED provides warnings of overheat, power failure, or fan failure. Refer to the table below for more information.

Information LED (OH/Fan Fail) LED States	
Status	Description
Solid red (on)	An overheat condition has occurred.
Blinking red (1 Hz)	Fan failure: check for an inoperative fan.
Blinking red (0.25 Hz)	Power failure: check for a non-operational power supply
Blinking red (10 Hz) (FP red LED)	CPLD recovery mode error(s)
Solid blue	Local UID is activated. Use this function to locate a unit in a rack mount environment that might be in need of service.
Blinking blue (1 Hz)	Remote UID is on. Use this function to identify a unit from a remote location that might be in need of service.
BIOS/BMC blinking blue (10 Hz)	BIOS/BMC: recovery and/or update in progress
Red Info LED blinking (10 Hz) and MB UID LED blue blinking (10 Hz)	CPLD: recovery and/or update in progress

NIC1/NIC2 (LAN1/LAN2)

The NIC (Network Interface Controller) LED connections for LAN port 1 is located on pin 6 of JFP1, and LAN port 2 is on pin 5. Refer to the table below for more information.

LAN1/LAN2 LED LED States	
Color	State
NIC 2: Blinking green	LAN 2: Active
NIC 1: Blinking green	LAN 1: Active

Drive Activity LED

The drive activity LED connection is located on pin 7 of JFP1. When this LED is blinking green, it indicates the drive is active. Refer to the table below for more information.

Drive LED LED State	
Color	State
Blinking Green	Drive Active

FP Power LED

The Front Panel Power LED connection is located on pin 9 of JFP1.

Power Fail LED

The Power Fail LED connection is located on pin 15 and pin 19 of JFP1. When this LED turns solid red, it indicates a power failure.

4.3 Jumpers

Explanation of Jumpers

To modify the operation of the motherboard, jumpers are used to choose between optional settings. Jumpers create shorts between two pins to change the function associated with it. Pin 1 is identified with a square solder pad on the printed circuit board. See the motherboard layout page for jumper locations.

Note 1: On a two-pin jumper, "Closed" means the jumper is on both pins and "Open" indicates the jumper is either on only one pin or has been completely removed.

Note 2: Unplug the power cord from all power supplies before adjusting jumper settings.

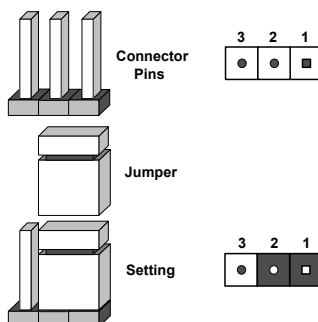

Figure 4-2. Jumpering Connector Pins

CMOS Clear

JBT1 is used to clear CMOS, which will also clear any passwords. Instead of pins, this jumper consists of contact pads to prevent accidentally clearing the contents of CMOS.

To Clear CMOS

1. First power down the system and unplug the power cord(s).
2. Remove the cover of the chassis to access the motherboard.
3. Remove the onboard battery from the motherboard.
4. Short the CMOS pads with a metal object such as a small screwdriver for at least four seconds.
5. Remove the screwdriver (or shorting device).
6. Re-install the motherboard battery.
7. Replace the cover, reconnect the power cord(s) and power on the system.

Notes: Clearing CMOS will also clear all passwords.

Do not use the PW_ON connector to clear CMOS.



JBT1 contact pads

UID Function/BMC Reset and System Reset

JRU1 is used in conjunction with Pin 2 of Front Control Panel (JFP1) to function as a System Reset button or a UID Function/BMC Reset button. To configure Pin 2 of JFP1 for front UID Function and BMC Reset use in a chassis that supports front UID connection, close Pins 2 and 3 of JRU1. To set Pin 2 of JFP1 for System Reset support, close Pins 1 and 2 of JRU1.

Front UID Function/BMC Reset and System Reset (JRU1) Jumper Settings	
Jumper Setting	Description
Pins 1-2	Pin 2 of JFP1: used for system reset support
Pins 2-3	Pin 2 of JFP1: used for front UID function and BMC reset support (Default)

4.4 Motherboard LED Indicators

Unit ID LED

The rear UID LED indicator is located at UID_LED. This UID indicator provides easy identification of a system that may need service.

UID LED LED Indicator	
LED Color	Definition
Blue: On	System Identified

BMC Heartbeat LED

A BMC Heartbeat LED is located at LEDBMC on the motherboard. When LEDBMC is blinking green, the BMC is functioning normally. Refer to the layout below for the location of LEDBMC.

BMC Heartbeat LED Indicator	
LED Color	Definition
Green: Blinking	BMC Normal

M.2 LED Indicators

Two M.2 LED indicators are located at LEDM2A and LEDM2B on the motherboard. When LEDM2A is blinking, M.2-P1 functions normally; while LEDM2B is blinking, M.2-P2 functions properly. Refer to the layout below for locations of LEDM2A and LEDM2B.

M.2 LED Indicators		
LED#	LED Color	State
LEDM2A	Green: Blinking	M.2-P1: M.2 device working properly
LEDM2B	Green: Blinking	M.2-P2: M.2 device working properly

Onboard Power LED

The Onboard Power LED is located at LEDPWR on the motherboard. When this LED is on, the system power is on. Be sure to turn off the system power and unplug the power cords before removing or installing components. Refer to the table below for more information.

Onboard Power LED Indicator	
LED Color	Definition
Off	System Power Off (power cable not connected)
Green	System Power On

Retimer Status LED Indicators

This motherboard supports four retimers for JMCIO1A/JMCIO1B, JMCIO2A/JMCIO2B, JMCIO6A/JMCIO6B, and JMCIO7A/JMCIO7B. The retimers can re-drive the PCIe signals from these MCIO connectors to the external GPU devices to help improve the quality of signals.

Retimer LED Indicators		
LED#	LED Status	State
LEDRT1_0	Solid On	Retimer (for JMCIO1A and JMCIO1B) working normally
LEDRT1_1	Blinking	
LEDRT1_2	Solid On	
LEDRT2_0	Solid On	Retimer (for JMCIO2A and JMCIO2B) working normally
LEDRT2_1	Blinking	
LEDRT2_2	Solid On	
LEDRT3_0	Solid On	Retimer (for JMCIO6A and JMCIO6B) working normally
LEDRT3_1	Blinking	
LEDRT3_2	Solid On	
LEDRT4_0	Solid On	Retimer (for JMCIO7A and JMCIO7B) working normally
LEDRT4_1	Blinking	
LEDRT4_2	Solid On	

Chapter 5

Software

After the hardware has been installed, you can install the Operating System (OS), configure RAID settings and install the drivers.

5.1 Microsoft Windows OS Installation

If you will be using RAID, you must configure RAID settings before installing the Windows OS and the RAID driver. Refer to the RAID Configuration User Guides posted on our website at www.supernmicro.com/support/manuals.

Installing the OS

1. Create a method to access the MS Windows installation ISO file. That might be USB flash or media drive, or the BMC KVM console.
2. Retrieve the proper RST/RSTe driver. Go to the Supermicro web page for your motherboard and click on "Download the Latest Drivers and Utilities", select the proper driver, and copy it to a USB flash drive.
3. Boot from a bootable device with Windows OS installation. You can see a bootable device list by pressing **F11** during the system startup.

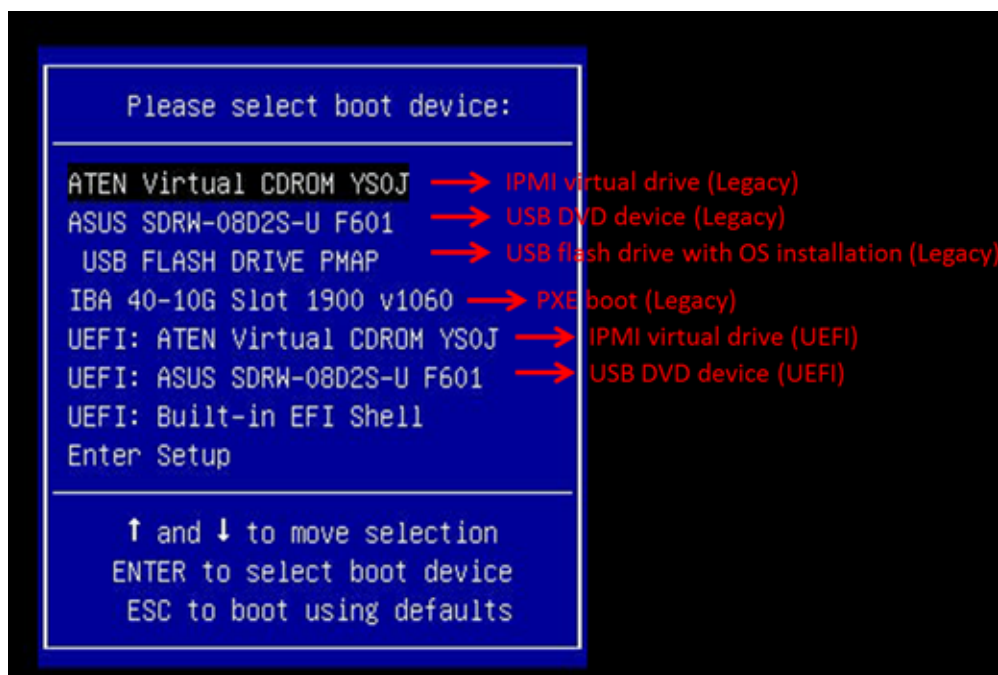

Figure 5-1. Select Boot Device

4. During Windows Setup, continue to the dialog where you select the drives on which to install Windows. If the disk you want to use is not listed, click on “Load driver” link at the bottom left corner.

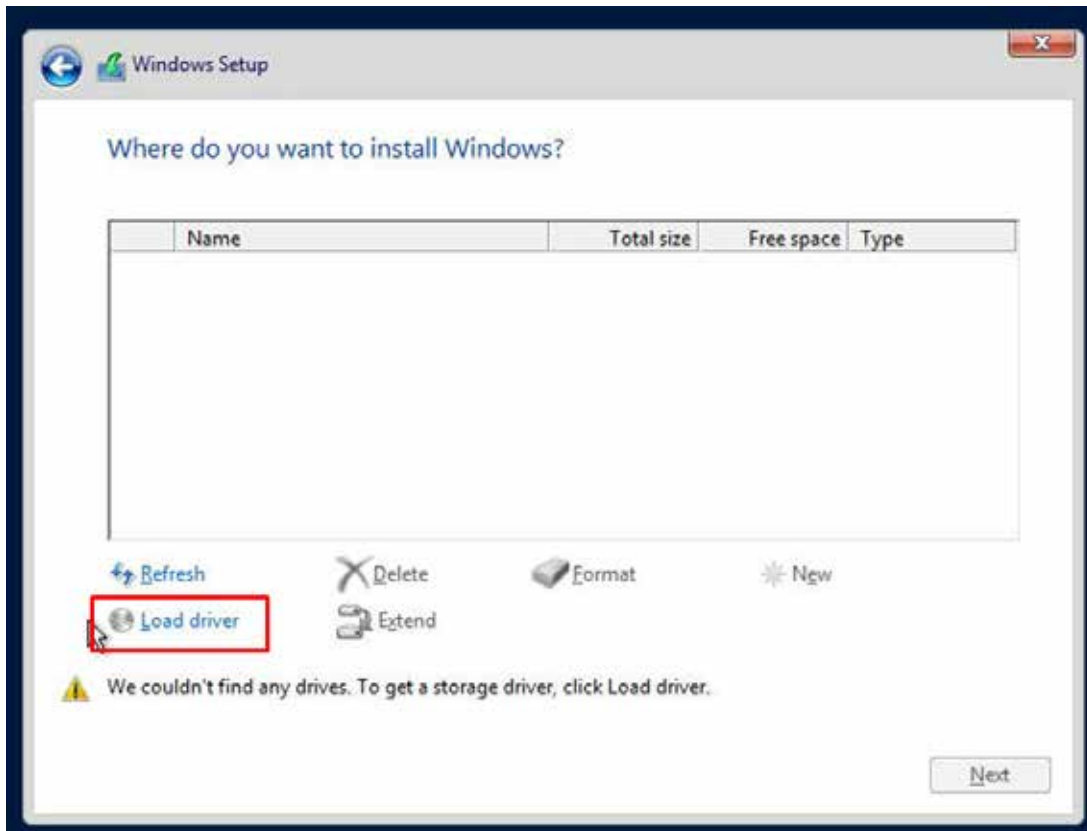

Figure 5-2. Load Driver Link

To load the driver, browse the USB flash drive for the proper driver files.

- For RAID, choose the SATA/sSATA RAID driver indicated then choose the storage drive on which you want to install it.
 - For non-RAID, choose the SATA/sSATA AHCI driver indicated then choose the storage drive on which you want to install it.
5. Once all devices are specified, continue with the installation.
 6. After the Windows OS installation has completed, the system will automatically reboot multiple times.

5.2 Driver Installation

The Supermicro website contains drivers and utilities for your system at <https://www.supermicro.com/wdl/driver>. Some of these must be installed, such as the chipset driver.

After accessing the website, go into the CDR_Images (in the parent directory of the above link) and locate the ISO file for your motherboard. Download this file to a USB flash or media drive. (You may also use a utility to extract the ISO file if preferred.)

Another option is to go to the Supermicro website at <http://www.supermicro.com/products/>. Find the product page for your motherboard, and "Download the Latest Drivers and Utilities".

Insert the flash drive or disk and the screenshot shown below should appear.

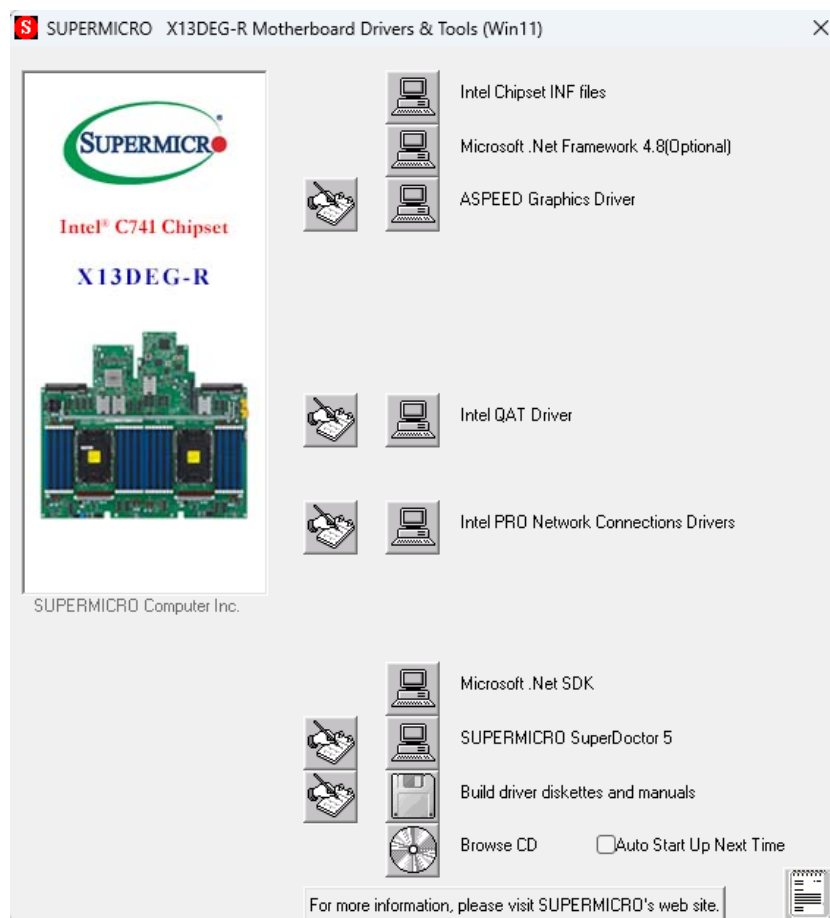

Figure 5-3. Driver & Tool Installation Screen

Note: Click the icons showing a hand writing on paper to view the readme files for each item. Click the computer icons to the right of these items to install each item (from top to the bottom) one at a time. **After installing each item, you must re-boot the system before moving on to the next item on the list.** The bottom icon with a CD on it allows you to view the entire contents.

5.3 BMC

The motherboard provides remote access, monitoring and management through the baseboard management controller (BMC) and other management controllers distributed among different system modules. There are several BIOS settings that are related to BMC. For general documentation and information on BMC, visit our website at:

www.supermicro.com/en/solutions/management-software/bmc-resources

BMC ADMIN User Password

For security, each system is assigned a unique default BMC password for the ADMIN user. This can be found on a sticker on the chassis and a sticker on the motherboard. The sticker also displays the BMC MAC address.



Figure 5-4. BMC Password Label

See [Chapter 1](#) for the location of the label.

Chapter 6

Optional Components

Refer to the [product page](#) for the latest information about optional system components.

6.1 Optional Parts List

Optional Parts List		
Description	Part Number	Quantity
M.2 Passive Heatsink (2280 and 22110 Form Factor)	SNK-C0156L	0
M.2 Passive Heatsink (2280 Form Factor)	SNK-C0160L	0
Nvidia SXM: HGX H100 4-GPU (80GB)	GPU-NVHGX-H100-48	0
2.5" Drive Tray	MCP-220-00187-0B	0

Chapter 7

Troubleshooting and Support

7.1 Information Resources

Website

A great deal of information is available on the Supermicro website, supermicro.com.



Figure 7-1. Supermicro Website

- Specifications for servers and other hardware are available by clicking the the **Products** option.

Direct Links for the SYS-221GE-TNHT-LC1 System

[SYS-221GE-TNHT-LC1](#) specifications page

X13DEG-R [motherboard page](#) for links to the Quick Reference Guide, User Manual, validated storage drives, etc.

Direct Links for General Support and Information

[Frequently Asked Questions](#)

[Add-on card descriptions](#)

[TPM User Guide](#)

[BMC User Guide](#)

[SuperDoctor5 Large Deployment Guide](#)

For validated memory, use our [Product Resources page](#)

[Product Matrices](#) page for links to tables summarizing specs for systems, motherboards, power supplies, riser cards, add-on cards, etc.

Direct Links (continued)

[Security Center](#) for recent security notices

[Supernano Phone and Addresses](#)

7.2 Baseboard Management Controller (BMC)

The system supports the Baseboard Management Controller (BMC). BMC is used to provide remote access, monitoring and management. There are several BIOS settings that are related to BMC.

For general documentation and information on BMC, please visit our website at: https://www.supernano.com/manuals/other/BMC_IPMI_X13_H13.pdf.

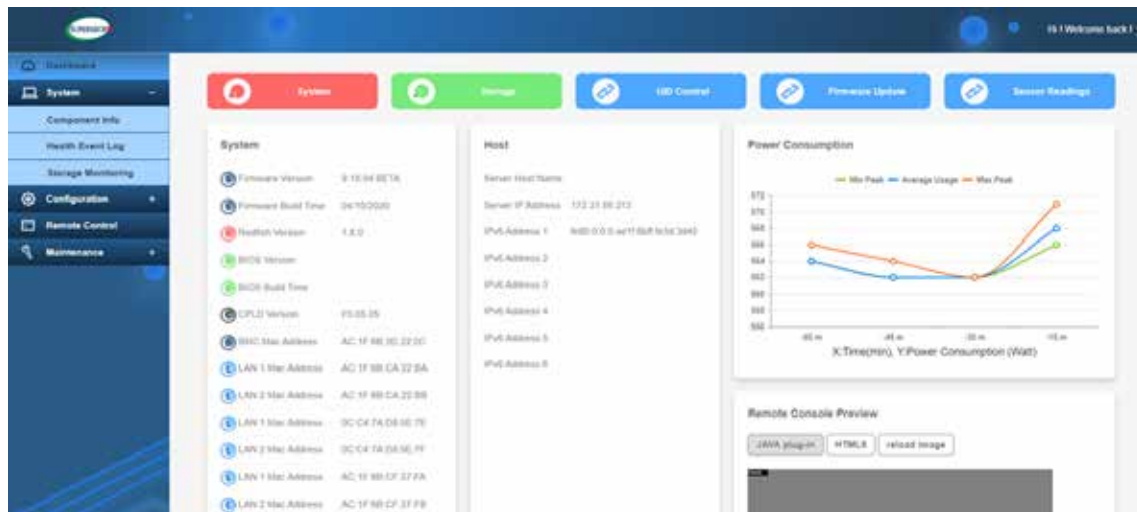

Figure 7-2. BMC Dashboard

7.3 Troubleshooting Procedures

Use the following procedures to troubleshoot your system. If you have followed all of the procedures below and still need assistance, refer to the [Technical Support Procedures](#) or [Returning Merchandise for Service](#) sections in this chapter. [Power down](#) the system before changing any non hot-swap hardware components.

General Technique

If you experience unstable operation or get no boot response, try:

1. With power off, remove all but one DIMM and other added components, such as add-on cards, from the motherboard. Make sure the motherboard is not shorted to the chassis.
2. Set all jumpers to their default positions.
3. Power up. If the system boots, check for memory errors and add-on card problems.

No Power

- Check that the power LED on the motherboard is on.

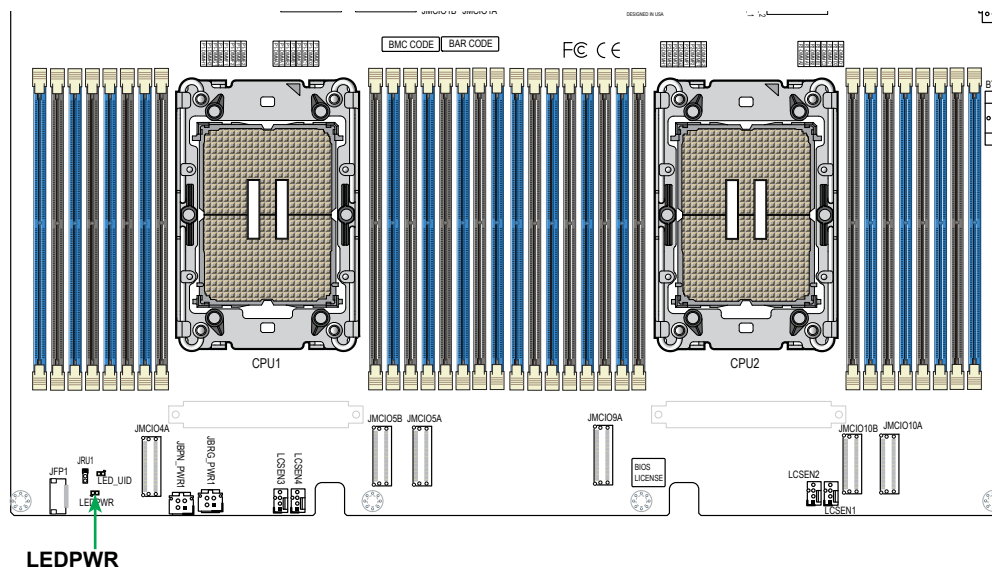

Figure 7-3. Location of the Motherboard Power LED

- Make sure that the power connector is connected to the power supply.
- Check that the motherboard battery still supplies approximately 3 VDC. If it does not, replace it.
- Check that the system input voltage is 100-120 V or 180-240 V.
- Turn the power switch on and off to test the system

No Video

If the power is on but you have no video, remove all add-on cards and cables.

System Boot Failure

If the system does not display Power-On-Self-Test (POST) or does not respond after the power is turned on, try the following:

- Turn on the system with only one DIMM module installed. If the system boots, check for bad DIMM modules or slots by following the Memory Errors Troubleshooting procedure below.

Memory Errors

- Make sure that the DIMM modules are properly and fully installed.
- Confirm that you are using the correct memory. Also, it is recommended that you use the same memory type and speed for all DIMMs in the system. See Section 3.5 for memory details.
- Check for bad DIMM modules or slots by swapping modules between slots and noting the results.

Losing the System Setup Configuration

- Use a high quality power supply. A poor quality power supply may cause the system to lose the CMOS setup information.
- Check that the motherboard battery still supplies approximately 3 VDC. If it does not, replace it.

If the above steps do not fix the setup configuration problem, contact your vendor for repairs.

If the System Becomes Unstable

If the system becomes unstable during or after OS installation, check the following:

- CPU/BIOS support: Make sure that your CPU is supported and that you have the latest BIOS installed in your system.
- Memory: Make sure that the memory modules are supported. Refer to the product page on our website at www.supermicro.com. Test the modules using **memtest86** or a similar utility.
- Storage drives: Make sure that all drives work properly. Replace if necessary.

- System cooling: Check that all system fans work properly. Check the hardware monitoring settings in the BMC to make sure that the CPU and system temperatures are within the normal range. Also check the Control panel Overheat LED.
- Adequate power supply: Make sure that the power supply provides adequate power to the system. Make sure that all power connectors are connected. Refer to the Supermicro website for the minimum power requirements.
- Proper software support: Make sure that the correct drivers are used.

If the system becomes unstable before or during OS installation, check the following:

- Source of installation: Make sure that the devices used for installation are working properly, including boot devices.
- Cable connection: Check to make sure that all cables are connected and working properly.
- Use the minimum configuration for troubleshooting: Remove all unnecessary components (starting with add-on cards first), and use the minimum configuration (but with a CPU and a memory module installed) to identify the trouble areas.
- Identify a bad component by isolating it. Check and change one component at a time.
 - Remove a component in question from the chassis, and test it in isolation. Replace it if necessary.
 - Or swap in a new component for the suspect one.
 - Or install the possibly defective component into a known good system. If the new system works, the component is likely not the cause or the problem.

7.4 Crash Dump Using BMC

In the event of a processor internal error (IERR) that crashes your system, you may want to provide information to support staff. You can download a crash dump of status information using BMC. The BMC manual is available at <https://www.supermicro.com/en/solutions/management-software/bmc-resources>.

Check BMC Error Log

1. Access the BMC web interface.

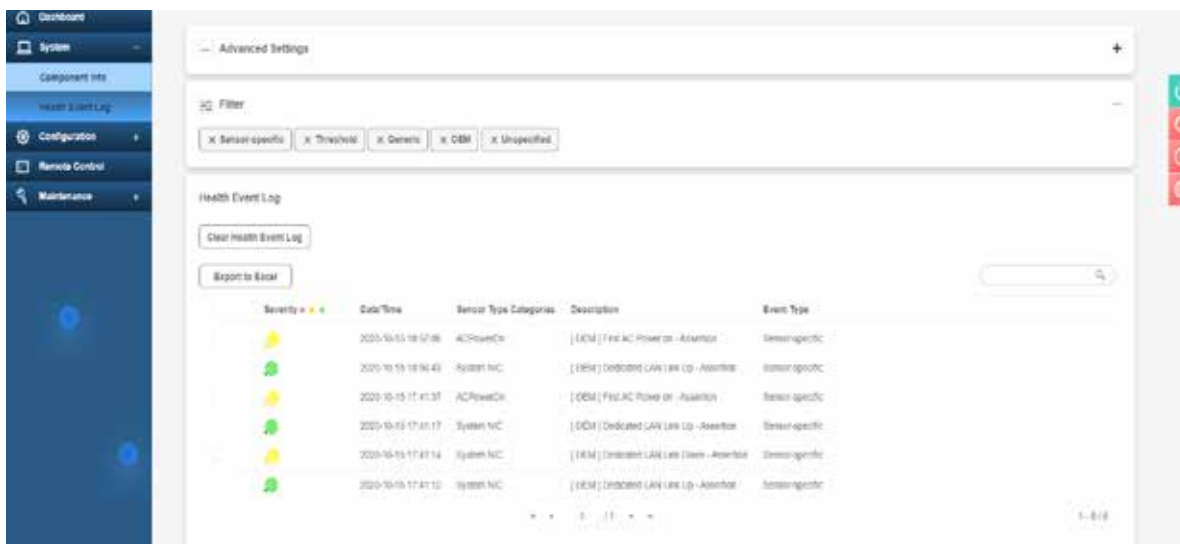

Figure 7-4. BMC Event Log

2. Click the **Server Health** tab, then **Event Log** to verify an IERR error.

In the event of an IERR, the BMC executes a crash dump. You must download the crash dump and save it.

7.5 UEFI BIOS Recovery

Warning: Do not upgrade the BIOS unless your system has a BIOS-related issue. Flashing the wrong BIOS can cause irreparable damage to the system. In no event shall Supermicro be liable for direct, indirect, special, incidental, or consequential damages arising from a BIOS update. If you do update the BIOS, do not shut down or reset the system while the BIOS is updating to avoid possible boot failure.

Overview

The Unified Extensible Firmware Interface (UEFI) provides a software-based interface between the operating system and the platform firmware in the pre-boot environment. The UEFI specification supports an architecture-independent mechanism that will allow the UEFI OS loader stored in an add-on card to boot the system. The UEFI offers clean, hands-off management to a computer during system boot.

Recovering the UEFI BIOS Image

A UEFI BIOS flash chip consists of a recovery BIOS block and a main BIOS block (a main BIOS image). The recovery block contains critical BIOS codes, including memory detection and recovery codes for the user to flash a healthy BIOS image if the original main BIOS image is corrupted. When the system power is turned on, the recovery block codes execute first. Once this process is complete, the main BIOS code will continue with system initialization and the remaining POST (Power-On Self-Test) routines.

Note 1: Follow the BIOS recovery instructions below for BIOS recovery when the main BIOS block crashes.

Note 2: When the BIOS recovery block crashes, you will need to follow the procedures to make a Returned Merchandise Authorization (RMA) request. Also, you may use the Supermicro Update Manager (SUM) Out-of-Band (https://www.supermicro.com.tw/products/nfo/SMS_SUM.cfm) to reflash the BIOS.

Recovering the Main BIOS Block with a USB Device

This feature allows the user to recover the main BIOS image using a USB-attached device without additional utilities used. A USB flash device such as a USB Flash Drive, or a USB CD/DVD ROM/RW device can be used for this purpose. However, a USB Hard Disk drive cannot be used for BIOS recovery at this time.

The file system supported by the recovery block is FAT (including FAT12, FAT16, and FAT32) which is installed on a bootable or non-bootable USB-attached device. However, the BIOS might need several minutes to locate the SUPER.ROM file if the media size becomes too large due to the huge volumes of folders and files stored in the device.

To perform UEFI BIOS recovery using a USB-attached device, follow the instructions below.

1. Using a different machine, copy the "Super.ROM" binary image file into the Root "\\" directory of a USB device or a writable CD/DVD.

Note 1: If you cannot locate the "Super.ROM" file in your drive disk, visit our website at www.supermicro.com to download the BIOS package. Extract the BIOS binary image into a USB flash device and rename it "Super.ROM" for the BIOS recovery use.

Note 2: Before recovering the main BIOS image, confirm that the "Super.ROM" binary image file you download is the same version or a close version meant for your motherboard.

2. Insert the USB device that contains the new BIOS image ("Super.ROM") into your USB drive and reset the system when the following screen appears.
3. After locating the healthy BIOS binary image, the system will enter the BIOS Recovery menu as shown below.



Note: At this point, you may decide if you want to start the BIOS recovery. If you decide to proceed with BIOS recovery, follow the procedures below.



4. When the screen as shown above displays, use the arrow keys to select the item "Proceed with flash update" and press the <Enter> key. You will see the BIOS recovery progress as shown in the screen below.

Note: *Do not interrupt the BIOS flashing process until it has completed.*

5. After the BIOS recovery process is complete, press any key to reboot the system.
6. Using a different system, extract the BIOS package into a USB flash drive.

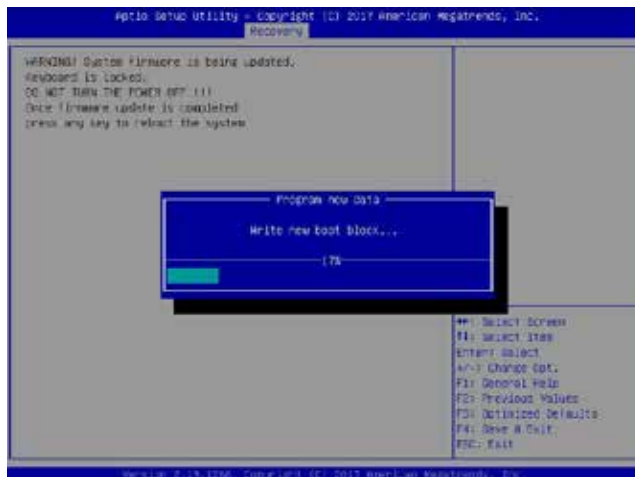

7. Press continuously during system boot to enter the BIOS Setup utility. From the top of the tool bar, select Boot to enter the submenu. From the submenu list, select Boot



Option #1 as shown below. Then, set Boot Option #1 to [UEFI AP:UEFI: Built-in EFI Shell]. Press <F4> to save the settings and exit the BIOS Setup utility.

8. When the UEFI Shell prompt appears, type fs# to change the device directory path. Go to the directory that contains the BIOS package you extracted earlier from Step 6. Enter flash.nsh BIOSname.### at the prompt to start the BIOS update process.

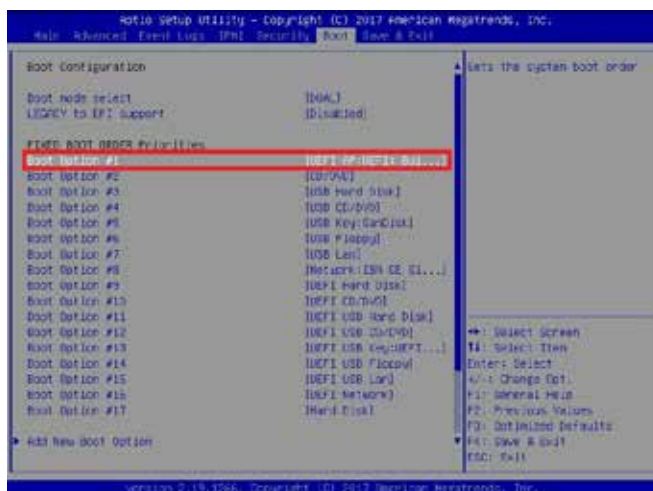

Note: *Do not interrupt this process* until the BIOS flashing is complete.

```

UEFI Interactive Shell v0.1
OK >
UEFI v0.10 (American Megatrends, Inc.)>
Press <Esc>
F0: #13a6c11d00f812b0c11
P:\EFI\AMIBOOT\FLASHUPDATE\ASB\ASB1.DOS\MSR_6427M132_6400_642
CR0000
B: #13a6c11d00f812b0c11
P:\EFI\AMIBOOT\FLASHUPDATE\ASB\ASB1.DOS\
Press <Esc> in 3 seconds to skip start-up, or any other key to continue.
Shell #0>
F0: #13a6c11d00f812b0c11
P:\EFI\AMIBOOT\FLASHUPDATE\ASB\ASB1.DOS\
P:\EFI\AMIBOOT\FLASHUPDATE\ASB\ASB1.DOS\

```

9. The screen above indicates that the BIOS update process is complete. When you see the screen above, unplug the AC power cable from the power supply, clear CMOS, and plug

```

Done.
[ Access Chip Part 0x ]
[ Read ]
Index out: 0x13
Done.
*****
*
* Program BIOS and MC (including PCH) regions...
*****
[
  BIOS Firmware Update (F01174_V0-02-02-120)
  Copyright (C)2012 American Megatrends, Inc. All Rights Reserved.
]
CPUID = 0062
Reading flash ..... done
- MC Data Size checking ..... ok
- PCH checksums ..... ok
- Check Redundant ..... OK
Erasing boot block ..... done
Updating boot block ..... done
Verifying boot block ..... done
Erasing main block ..... done
Erasing main block ..... done

```

the AC power cable in the power supply again to power on the system.

10. Press continuously to enter the BIOS Setup utility.

```

Verifying MB Flash ..... Done
- Update success for PCH
- Update success for CPU
- Successful Update Recovery Loader to EPROM
- Successful Update PCH
- Successful Update PCH
- Successful Update MC, FWH and I/O
- Successful Update FWH and I/O
- MC Update Image update success
WARNING: System must power-off to have the changes take effect!
Flashing PCH:\EFI\AMIBOOT\FLASHUPDATE\ASB\ASB1.DOS\
Done
Flashing PCH:\EFI\AMIBOOT\FLASHUPDATE\ASB\ASB1.DOS\
Transfer done
Done
*****
*
* Please ignore this "Shell" prompt read from F0 - Delkey timer!
* Warning message time to 0. This has started flashing process.
*****
Deleting .....
Delete successful.
Flashing .....

```

11. Press <F3> to load the default settings.
12. After loading the default settings, press <F4> to save the settings and exit the BIOS Setup utility.

7.6 CMOS Clear

JBT1 is used to clear CMOS, which will also clear any passwords. Instead of pins, this jumper consists of contact pads to prevent accidentally clearing the contents of CMOS.

To Clear CMOS

1. First [power down](#) the system completely.
2. Remove the [chassis cover](#) to access the motherboard.
3. [Remove the onboard battery](#) from the motherboard.
4. Short the CMOS pads with a metal object such as a small screwdriver for at least four seconds.
5. Remove the screwdriver or shorting device.
6. Re-install the battery.
7. Replace the cover, reconnect the power cords and power on the system.

Notes: Clearing CMOS will also clear all passwords.

Do not use the PW_ON connector to clear CMOS.



JBT1 contact pads

7.7 Where to Get Replacement Components

If you need replacement parts for your system, to ensure the highest level of professional service and technical support, purchase exclusively from our Supermicro Authorized Distributors/System Integrators/Resellers. A list can be found at: <http://www.supermicro.com>. Click the "Where to Buy" tab.

7.8 Reporting an Issue

Technical Support Procedures

Before contacting Technical Support, please take the following steps. If your system was purchased through a distributor or reseller, please contact them for troubleshooting services. They have the best knowledge of your specific system configuration.

1. Please review the [Troubleshooting Procedures](#) in this manual and [Frequently Asked Questions](#) on our website before contacting Technical Support.
2. BIOS upgrades can be downloaded from our website. **Note:** Not all BIOS can be flashed depending on the modifications to the boot block code.
3. If you still cannot resolve the problem, include the following information when contacting us for technical support:
 - System, motherboard, and chassis model numbers and PCB revision number
 - BIOS release date/version (this can be seen on the initial display when your system first boots up)
 - System configuration

An example of a Technical Support form is posted on our [website](#). Distributors: For immediate assistance, please have your account number ready when contacting our technical support department by email.

Returning Merchandise for Service

A receipt or copy of your invoice marked with the date of purchase is required before any warranty service will be rendered. You can obtain service by calling your vendor for a Returned Merchandise Authorization (RMA) number. When returning to the manufacturer, the RMA number should be prominently displayed on the outside of the shipping carton, and mailed prepaid or hand-carried. Shipping and handling charges will be applied for all orders that must be mailed when service is complete.

For faster service, RMA authorizations may be requested online (<http://www.supermicro.com/support/rma/>).

Whenever possible, repack the chassis in the original Supermicro carton, using the original packaging material. If these are no longer available, be sure to pack the chassis securely, using packaging material to surround the chassis so that it does not shift within the carton and become damaged during shipping.

This warranty only covers normal consumer use and does not cover damages incurred in shipping or from failure due to the alteration, misuse, abuse or improper maintenance of products.

During the warranty period, contact your distributor first for any product problems.

Vendor Support Filing System

For issues related to Intel, use the Intel IPS filing system:

<https://www.intel.com/content/www/us/en/design/support/ips/training/welcome.html>

For issues related to Red Hat Enterprise Linux, since it is a subscription based OS, contact your account representative.

7.9 Feedback

Supermicro values your feedback as we strive to improve our customer experience in all facets of our business. Please email us at techwriterteam@supermicro.com to provide feedback on our manuals.

Appendix A

Standardized Warning Statements for AC Systems

About Standardized Warning Statements

The following statements are industry standard warnings, provided to warn the user of situations which have the potential for bodily injury. Should you have questions or experience difficulty, contact Supermicro's Technical Support department for assistance. Only certified technicians should attempt to install or configure components.

Read this appendix in its entirety before installing or configuring components in the Supermicro chassis.

These warnings may also be found on our website at http://www.supermicro.com/about/policies/safety_information.cfm.

Warning Definition



Warning! This warning symbol means danger. You are in a situation that could cause bodily injury. Before you work on any equipment, be aware of the hazards involved with electrical circuitry and be familiar with standard practices for preventing accidents.

警告の定義

この警告サインは危険を意味します。

人身事故につながる可能性がありますので、いずれの機器でも動作させる前に、電気回路に含まれる危険性に注意して、標準的な事故防止策に精通して下さい。

此警告符号代表危險。

您正处于可能受到严重伤害的工作环境中。在您使用设备开始工作之前，必须充分意识到触电的危险，并熟练掌握防止事故发生的标准工作程序。请根据每项警告结尾的声明号码找到此设备的安全性警告说明的翻译文本。

此警告符號代表危險。

您正處於可能身體可能會受損傷的工作環境中。在您使用任何設備之前，請注意觸電的危險，並且要熟悉預防事故發生的標準工作程序。請依照每一注意事項後的號碼找到相關的翻譯說明內容。

Warnung

WICHTIGE SICHERHEITSHINWEISE

Dieses Warnsymbol bedeutet Gefahr. Sie befinden sich in einer Situation, die zu Verletzungen führen kann. Machen Sie sich vor der Arbeit mit Geräten mit den Gefahren elektrischer Schaltungen und den üblichen Verfahren zur Vorbeugung vor Unfällen vertraut. Suchen Sie mit der am Ende jeder Warnung angegebenen Anweisungsnummer nach der jeweiligen Übersetzung in den übersetzten Sicherheitshinweisen, die zusammen mit diesem Gerät ausgeliefert wurden.

BEWAHREN SIE DIESE HINWEISE GUT AUF.

INSTRUCCIONES IMPORTANTES DE SEGURIDAD

Este símbolo de aviso indica peligro. Existe riesgo para su integridad física. Antes de manipular cualquier equipo, considere los riesgos de la corriente eléctrica y familiarícese con los procedimientos estándar de prevención de accidentes. Al final de cada advertencia encontrará el número que le ayudará a encontrar el texto traducido en el apartado de traducciones que acompaña a este dispositivo.

GUARDE ESTAS INSTRUCCIONES.

IMPORTANTES INFORMATIONS DE SÉCURITÉ

Ce symbole d'avertissement indique un danger. Vous vous trouvez dans une situation pouvant entraîner des blessures ou des dommages corporels. Avant de travailler sur un équipement, soyez conscient des dangers liés aux circuits électriques et familiarisez-vous avec les procédures couramment utilisées pour éviter les accidents. Pour prendre connaissance des traductions des avertissements figurant dans les consignes de sécurité traduites qui accompagnent cet appareil, référez-vous au numéro de l'instruction situé à la fin de chaque avertissement.

CONSERVEZ CES INFORMATIONS.

תקנון הזהרות אזהרה

הזהרות הבאות הן אזהרות על פי תקני התעשייה, על מנת להזהיר את המשתמש מפני חבלה פיזית אפשרית. במידה ויש שאלות או היתקלות בבעיה כלשהי, יש ליצור קשר עם מחלקת תמיכה טכנית של סופרמיקרו. טכנאים מוסמכים בלבד רשאים להתקין או להגדיר את הרכיבים. יש לקרוא את הנספח במלואו לפני התקנת או הגדרת הרכיבים במארזי סופרמיקרו.

اَكْ ف حالة وُكِي اَي تتسبب ف اصابة جسدهُ هذا الزهز عْ خطر! تحذُرُ .
 قبل اَي تعول على اَي هعدات، كي على علن بالوخاطز ال اُجوة عي الذوائر
 الكهزبائِة
 وكي على دراةُ بالووارسات النقااِة لو عْ وقع اَي حادث
 استخدم رقن الب اِى الو صُص ف هاةُ كل تحذُرُ للعشر تزجوتها

안전을 위한 주의사항

경고!

이 경고 기호는 위험이 있음을 알려 줍니다. 작업자의 신체에 부상을 야기 할 수 있는 상태에 있게 됩니다. 모든 장비에 대한 작업을 수행하기 전에 전기회로와 관련된 위험요소들을 확인하시고 사전에 사고를 방지할 수 있도록 표준 작업절차를 준수해 주시기 바랍니다.

해당 번역문을 찾기 위해 각 경고의 마지막 부분에 제공된 경고문 번호를 참조하십시오

BELANGRIJKE VEILIGHEIDSINSTRUCTIES

Dit waarschuwings symbool betekent gevaar. U verkeert in een situatie die lichamelijk letsel kan veroorzaken. Voordat u aan enige apparatuur gaat werken, dient u zich bewust te zijn van de bij een elektrische installatie betrokken risico's en dient u op de hoogte te zijn van de standaard procedures om ongelukken te voorkomen. Gebruik de nummers aan het eind van elke waarschuwing om deze te herleiden naar de desbetreffende locatie.

BEWAAR DEZE INSTRUCTIES

Installation Instructions



Warning! Read the installation instructions before connecting the system to the power source.

設置手順書

システムを電源に接続する前に、設置手順書をお読み下さい。

警告

将此系统连接电源前,请先阅读安装说明。

警告

將系統與電源連接前，請先閱讀安裝說明。

Warnung

Vor dem Anschließen des Systems an die Stromquelle die Installationsanweisungen lesen.

¡Advertencia!

Lea las instrucciones de instalación antes de conectar el sistema a la red de alimentación.

Attention

Avant de brancher le système sur la source d'alimentation, consulter les directives d'installation.

יש לקרוא את הוראות התקנה לפני חיבור המערכת למקור מתח.

اقرأ إرشادات التركيب قبل توصيل النظام إلى مصدر للطاقة

시스템을 전원에 연결하기 전에 설치 안내를 읽어주십시오.

Waarschuwing

Raadpleeg de installatie-instructies voordat u het systeem op de voedingsbron aansluit.

Circuit Breaker

Warning! This product relies on the building's installation for short-circuit (overcurrent) protection. Ensure that the protective device is rated not greater than: 250 V, 20 A.

サーキット・ブレーカー

この製品は、短絡(過電流)保護装置がある建物での設置を前提としています。

保護装置の定格が250 V、20 Aを超えないことを確認下さい。

警告

此产品的短路(过载电流)保护由建筑物的供电系统提供,确保短路保护设备的额定电流不大于250V,20A。

警告

此產品的短路(過載電流)保護由建築物的供電系統提供,確保短路保護設備的額定電流不大於250V,20A。

Warnung

Dieses Produkt ist darauf angewiesen, dass im Gebäude ein Kurzschluss- bzw. Überstromschutz installiert ist. Stellen Sie sicher, dass der Nennwert der Schutzvorrichtung nicht mehr als: 250 V, 20 A beträgt.

¡Advertencia!

Este equipo utiliza el sistema de protección contra cortocircuitos (o sobrecorrientes) del edificio. Asegúrese de que el dispositivo de protección no sea superior a: 250 V, 20 A.

Attention

Pour ce qui est de la protection contre les courts-circuits (surtension), ce produit dépend de l'installation électrique du local. Vérifiez que le courant nominal du dispositif de protection n'est pas supérieur à :250 V, 20 A.

מוצר זה מסתמך על הגנה המותקנת במבנים למניעת קצר חשמלי. יש לוודא כי המכשיר המגן מפני הקצר החשמלי הוא לא יותר מ-250VDC, 20A

هذا المنتج يعتمد على معدات الحماية من الدوائر القصيرة التي تم تثبيتها في المبنى
تأكد من أن تقييم الجهاز الوقائي ليس أكثر من : 20A, 250V

경고!

이 제품은 전원의 단락(과전류)방지에 대해서 전적으로 건물의 관련 설비에 의존합니다. 보호장치의 정격이 반드시 250V(볼트), 20A(암페어)를 초과하지 않도록 해야 합니다.

Waarschuwing

Dit product is afhankelijk van de kortsluitbeveiliging (overspanning) van uw elektrische installatie. Controleer of het beveiligde apparaat niet groter gedimensioneerd is dan 250V, 20A.

Power Disconnection Warning



Warning! The system must be disconnected from all sources of power and the power cord removed from the power supply module(s) before accessing the chassis interior to install or remove system components (except for hot-swap components).



電源切断の警告

システムコンポーネントの取り付けまたは取り外しのために、シャーシ内部にアクセスするには、システムの電源はすべてのソースから切断され、電源コードは電源モジュールから取り外す必要があります。

警告

在你打开机箱并安装或移除内部器件前,必须将系统完全断电,并移除电源线。

警告

在您打開機殼安裝或移除內部元件前，必須將系統完全斷電，並移除電源線。

Warnung

Das System muss von allen Quellen der Energie und vom Netzanschlusskabel getrennt sein, das von den Spg.Versorgungsteilmodulen entfernt wird, bevor es auf den Chassisinnenraum zurückgreift, um Systemsbestandteile anzubringen oder zu entfernen.

¡Advertencia!

El sistema debe ser disconnected de todas las fuentes de energía y del cable eléctrico quitado de los módulos de fuente de alimentación antes de tener acceso el interior del chasis para instalar o para quitar componentes de sistema.

Attention

Le système doit être débranché de toutes les sources de puissance ainsi que de son cordon d'alimentation secteur avant d'accéder à l'intérieur du chasis pour installer ou enlever des composants de système.

אזהרה מפני ניתוק חשמלי

אזהרה!

יש לנתק את המערכת מכל מקורות החשמל ויש להסיר את כבל החשמלי מהספק לפני גישה לחלק הפנימי של המארז לצורך התקנת או הסרת רכיבים.

يجب فصل انظاؤ من جميع مصادر انطاقت وإزانت سهك انكهرباء من وحدة امداد انطاقت قيم

انصل إلى امناطق انداخييت نههيكم نشييج أو إزانت مكناث الجهاز

경고!

시스템에 부품들을 장착하거나 제거하기 위해서는 새시 내부에 접근하기 전에 반드시 전원 공급장치로부터 연결되어있는 모든 전원과 전기코드를 분리해주어야 합니다.

Waarschuwing

Voordat u toegang neemt tot het binnenwerk van de behuizing voor het installeren of verwijderen van systeem onderdelen, dient u alle spanningsbronnen en alle stroomkabels aangesloten op de voeding(en) van de behuizing te verwijderen

Equipment Installation



Warning! Only authorized personnel and qualified service persons should be allowed to install, replace, or service this equipment.

機器の設置

トレーニングを受け認定された人だけがこの装置の設置、交換、またはサービスを許可されています。

警告

只有经过培训且具有资格的人员才能进行此设备的安装、更换和维修。

警告

只有經過受訓且具資格人員才可安裝、更換與維修此設備。

Warnung

Nur autorisiertes Personal und qualifizierte Servicetechniker dürfen dieses Gerät installieren, austauschen oder warten..

¡Advertencia!

Sólo el personal autorizado y el personal de servicio calificado deben poder instalar, reemplazar o dar servicio a este equipo.

Attention

Seul le personnel autorisé et le personnel de maintenance qualifié doivent être autorisés à installer, remplacer ou entretenir cet équipement..

אזהרה!

יש לאפשר רק צוות מורשה ואנשי שירות מוסמכים להתקין, להחליף או לטפל בציוד זה.

ينبغي السماح فقط للموظفين المعتمدين وأفراد الخدمة المؤهلين بتركيب هذا الجهاز أو استبداله أو صيانته.

경고!

승인된 직원과 자격을 갖춘 서비스 담당자만이 이 장비를 설치, 교체 또는 서비스할 수 있습니다.

Waarschuwing

Alleen geautoriseerd personeel en gekwalificeerd onderhoudspersoneel mag deze apparatuur installeren, vervangen of onderhouden..

Restricted Area

Warning! This unit is intended for installation in restricted access areas. A restricted access area can be accessed only through the use of a special tool, lock and key, or other means of security. (This warning does not apply to workstations).

アクセス制限区域

このユニットは、アクセス制限区域に設置されることを想定しています。

アクセス制限区域は、特別なツール、鍵と錠前、その他のセキュリティの手段を用いてのみ出入りが可能です。

警告

此部件应安装在限制进出的场所，限制进出的场所指只能通过使用特殊工具、锁和钥匙或其它安全手段进出的场所。

警告

此裝置僅限安裝於進出管制區域，進出管制區域係指僅能以特殊工具、鎖頭及鑰匙或其他安全方式才能進入的區域。

Warnung

Diese Einheit ist zur Installation in Bereichen mit beschränktem Zutritt vorgesehen. Der Zutritt zu derartigen Bereichen ist nur mit einem Spezialwerkzeug, Schloss und Schlüssel oder einer sonstigen Sicherheitsvorkehrung möglich.

¡Advertencia!

Esta unidad ha sido diseñada para instalación en áreas de acceso restringido. Sólo puede obtenerse acceso a una de estas áreas mediante la utilización de una herramienta especial, cerradura con llave u otro medio de seguridad.

Attention

Cet appareil doit être installée dans des zones d'accès réservés. L'accès à une zone d'accès réservé n'est possible qu'en utilisant un outil spécial, un mécanisme de verrouillage et une clé, ou tout autre moyen de sécurité.

אזור עם גישה מוגבלת

אזהרה!

יש להתקין את היחידה באזורים שיש בהם הגבלת גישה. הגישה ניתנת בעזרת 'כלי אבטחה בלבד' (מפתח, מנעול וכד.).

تخصيص هذه انحدة نترك بها ف مناطق محظورة تم .

،ممكن اننصل إن منطقت محظورة فقط من خلال استخداو أداة خاصت أو أ وس هُت أخري نلالأمما ققم ومفتاح

경고!

이 장치는 접근이 제한된 구역에 설치하도록 되어있습니다. 특수도구, 잠금 장치 및 키, 또는 기타 보안 수단을 통해서만 접근 제한 구역에 들어갈 수 있습니다.

Waarschuwing

Dit apparaat is bedoeld voor installatie in gebieden met een beperkte toegang. Toegang tot dergelijke gebieden kunnen alleen verkregen worden door gebruik te maken van speciaal gereedschap, slot en sleutel of andere veiligheidsmaatregelen.

Battery Handling



CAUTION: There is risk of explosion if the battery is replaced by an incorrect type. Replace the battery only with the same or equivalent type recommended by the manufacturer. Dispose of used batteries according to the manufacturer's instructions

電池の取り扱い

バッテリーを間違ったタイプに交換すると爆発の危険があります。交換する電池はメーカーが推奨する型、または同等のものを使用下さい。使用済電池は製造元の指示に従って処分して下さい。

警告

如果更换的电池类型不正确，则存在爆炸危险。请只使用同类电池或制造商推荐的功能相当的电池更换原有电池。请按制造商的说明处理废旧电池。

警告

如果更換的電池類型不正確，則有爆炸危險。請使用製造商建議之相同或功能相當的電池更換原有電池。請按照製造商的說明指示處理廢棄舊電池。

WARNUNG

Es besteht Explosionsgefahr, wenn die Batterie durch einen falschen Typ ersetzt wird. Ersetzen Sie die Batterie nur durch den gleichen oder vom Hersteller empfohlenen Batterietyp. Entsorgen Sie die benutzten Batterien nach den Anweisungen des Herstellers.

ATTENTION

Il existe un risque d'explosion si la batterie est remplacée par un type incorrect. Ne la remplacer que par une pile de type semblable ou équivalent, recommandée par le fabricant. Jeter les piles usagées conformément aux instructions du fabricant.

ADVERTENCIA

Existe riesgo de explosión si la batería se reemplaza por un tipo incorrecto. Reemplazar la batería exclusivamente con el mismo tipo o el equivalente recomendado por el fabricante. Desechar las baterías gastadas según las instrucciones del fabricante.

אזהרה!

קיימת סכנת פיצוץ אם הסוללה תוחלף בסוג שגוי. יש להחליף את הסוללה בסוג התואם מחברת יצרן מומלצת. סילוק הסוללות המשומשות יש לבצע לפי הוראות היצרן.

هناك خطر الانفجار إذا تم استبدال البطارية بنوع غير صحيح.
 اسحبذال البطارية
 فقط بنفس النوع أو ما يعادلها مما أوصت به الشركة المصنعة
 جخلص من البطاريات المسحمة وفقا لعمليات الشركة الصانعة

경고!

배터리를 잘못된 종류로 교체하면 폭발의 위험이 있습니다. 기존 배터리와 동일하거나 제조사에서 권장하는 동등한 종류의 배터리로만 교체해야 합니다. 제조사의 안내에 따라 사용된 배터리를 처리하여 주십시오.

WAARSCHUWING

Er bestaat explosiegevaar als de batterij wordt vervangen door een verkeerd type. Vervang de batterij slechts met hetzelfde of een equivalent type die door de fabrikant aanbevolen wordt. Gebruikte batterijen dienen overeenkomstig fabrieksvoorschriften afgevoerd te worden.

Redundant Power Supplies



Warning! This unit might have more than one power supply connection. All connections must be removed to de-energize the unit.

冗長電源装置

このユニットは複数の電源装置が接続されている場合があります。

ユニットの電源を切るためには、すべての接続を取り外さなければなりません。

警告

此部件连接的电源可能不止一个，必须将所有电源断开才能停止给该部件供电。

警告

此装置连接的电源可能不只一个，必须切断所有电源才能停止对该装置的供电。

Warnung

Dieses Gerät kann mehr als eine Stromzufuhr haben. Um sicherzustellen, dass der Einheit kein Strom zugeführt wird, müssen alle Verbindungen entfernt werden.

¡Advertencia!

Puede que esta unidad tenga más de una conexión para fuentes de alimentación. Para cortar por completo el suministro de energía, deben desconectarse todas las conexiones.

Attention

Cette unité peut avoir plus d'une connexion d'alimentation. Pour supprimer toute tension et tout courant électrique de l'unité, toutes les connexions d'alimentation doivent être débranchées.

אם קיים יותר מספק אחד

אזהרה!

ליחידה יש יותר מחיבור אחד של ספק. יש להסיר את כל החיבורים על מנת לרוקן את היחידה.

قد يكون لهذا الجهاز عدة اتصالات بوحدات امداد الطاقة .
يجب إزالة كافة الاتصالات لعسل الوحدة عن الكهرباء

경고!

이 장치에는 한 개 이상의 전원 공급 단자가 연결되어 있을 수 있습니다. 이 장치에 전원을 차단하기 위해서는 모든 연결 단자를 제거해야만 합니다.

Waarschuwing

Deze eenheid kan meer dan één stroomtoevoeraansluiting bevatten. Alle aansluitingen dienen verwijderd te worden om het apparaat stroomloos te maken.

Backplane Voltage



Warning! Hazardous voltage or energy is present on the backplane when the system is operating. Use caution when servicing.

バックプレーンの電圧

システムの稼働中は危険な電圧または電力が、バックプレーン上にかかっています。

修理する際には注意ください。

警告

当系统正在进行时，背板上有很危险的电压或能量，进行维修时务必小心。

警告

當系統正在進行時，背板上危險的電壓或能量，進行維修時務必小心。

Warnung

Wenn das System in Betrieb ist, treten auf der Rückwandplatine gefährliche Spannungen oder Energien auf. Vorsicht bei der Wartung.

¡Advertencia!

Cuando el sistema está en funcionamiento, el voltaje del plano trasero es peligroso. Tenga cuidado cuando lo revise.

Attention

Lorsque le système est en fonctionnement, des tensions électriques circulent sur le fond de panier. Prendre des précautions lors de la maintenance.

מתח בפנל האחורי

אזהרה!

קיימת סכנת מתח בפנל האחורי בזמן תפעול המערכת. יש להיזהר במהלך

העבודה.

هناك خطر من التيار الكهربائي أو الطاقة المتجددة على اللوحة
عندما يكون النظام يعمل كه حذرا عند خدمة هذا الجهاز

경고!

시스템이 동작 중일 때 후면판 (Backplane)에는 위험한 전압이나 에너지가 발생 합니다.
서비스 작업 시 주의하십시오.

Waarschuwing

Een gevaarlijke spanning of energie is aanwezig op de backplane wanneer het systeem in gebruik is. Voorzichtigheid is geboden tijdens het onderhoud.

Comply with Local and National Electrical Codes



Warning! Installation of the equipment must comply with local and national electrical codes.

地方および国の電気規格に準拠

機器の取り付けはその地方および国の電気規格に準拠する必要があります。

警告

设备安装必须符合本地与本国电气法规。

警告

設備安裝必須符合本地與本國電氣法規。

Warnung

Die Installation der Geräte muss den Sicherheitsstandards entsprechen.

¡Advertencia!

La instalación del equipo debe cumplir con las normas de electricidad locales y nacionales.

Attention

L'équipement doit être installé conformément aux normes électriques nationales et locales.

תיאום חוקי החשמל הארצי
אזהרה!
התקנת הציוד חייבת להיות תואמת לחוקי החשמל המקומיים והארציים.

تركيب المعدات الكهربائية يجب أن يمتثل للقوايه المحلية والبطية المتعلقة
بالكهرباء

경고!

현 지역 및 국가의 전기 규정에 따라 장비를 설치해야 합니다.

Waarschuwing

Bij installatie van de apparatuur moet worden voldaan aan de lokale en nationale elektriciteitsvoorschriften.

Product Disposal



Warning! Ultimate disposal of this product should be handled according to all national laws and regulations.

製品の廃棄

この製品を廃棄処分する場合、国の関係する全ての法律・条例に従い処理する必要があります。

警告

本产品的废弃处理应根据所有国家的法律和规章进行。

警告

本產品的廢棄處理應根據所有國家的法律和規章進行。

Warnung

Die Entsorgung dieses Produkts sollte gemäß allen Bestimmungen und Gesetzen des Landes erfolgen.

¡Advertencia!

Al deshacerse por completo de este producto debe seguir todas las leyes y reglamentos nacionales.

Attention

La mise au rebut ou le recyclage de ce produit sont généralement soumis à des lois et/ou directives de respect de l'environnement. Renseignez-vous auprès de l'organisme compétent.

סילוק המוצר

אזהרה!

סילוק סופי של מוצר זה חייב להיות בהתאם להנחיות וחוקי המדינה.

التخلص النهائي من هذا المنتج ينبغي التعامل معه وفقا لجميع القوانين واللوائح الوطنية عند

경고!

이 제품은 해당 국가의 관련 법규 및 규정에 따라 폐기되어야 합니다.

Waarschuwing

De uiteindelijke verwijdering van dit product dient te geschieden in overeenstemming met alle nationale wetten en reglementen.

Fan Warning



Warning! Hazardous moving parts. Keep away from moving fan blades. The fans might still be turning when you remove the fan assembly from the chassis. Keep fingers, screwdrivers, and other objects away from the openings in the fan assembly's housing.

ファンの警告

警告!回転部品に注意。運転中は回転部(羽根)に触れないでください。シャーシから冷却ファン装置を取り外した際、ファンがまだ回転している可能性があります。ファンの開口部に、指、ドライバー、およびその他のものを近づけないで下さい。

警告!

警告! 危险的可移动性零件。请务必与转动的风扇叶片保持距离。当您从机架移除风扇装置，风扇可能仍在转动。小心不要将手指、螺丝起子和其他物品太靠近风扇

警告

危险的可移动性零件。请务必与转动的风扇叶片保持距离。当您从机架移除风扇装置，风扇可能仍在转动。小心不要将手指、螺丝起子和其他物品太靠近风扇。

Warnung

Gefährlich Bewegende Teile. Von den bewegenden Lüfterblätter fern halten. Die Lüfter drehen sich u. U. noch, wenn die Lüfterbaugruppe aus dem Chassis genommen wird. Halten Sie Finger, Schraubendreher und andere Gegenstände von den Öffnungen des Lüftergehäuses entfernt.

¡Advertencia!

Riesgo de piezas móviles. Mantener alejado de las aspas del ventilador. Los ventiladores podran dar vuelta cuando usted quite el montaje del ventilador del chasis. Mantenga los dedos, los destornilladores y todos los objetos lejos de las aberturas del ventilador

Attention

Pieces mobiles dangereuses. Se tenir a l'écart des lames du ventilateur Il est possible que les ventilateurs soient toujours en rotation lorsque vous retirerez le bloc ventilateur du châssis. Prenez garde à ce que doigts, tournevis et autres objets soient éloignés du logement du bloc ventilateur.

אזהרה!

חלקים נעים מסוכנים. התרחק מלהבי המאוורר בפעולה כאשר מסירים את חלקי המאוורר מהמארז, יתכן והמאווררים עדיין עובדים. יש להרחיק למרחק בטוח את האצבעות וכלי עבודה שונים מהפתחים בתוך המאוורר

تحذير! أجزاء متحركة خطيرة. ابتعد عن شفرات المروحة المتحركة. من الممكن أن المراوح لا تزال تدور عند إزالة كتلة المروحة من الهيكل يجب إبقاء الأصابع ومفكات البراغي وغيرها من الأشياء بعيدا عن الفتحات في كتلة المروحة

경고!

움직이는 위험한 부품. 회전하는 송풍 날개에 접근하지 마세요. 새시로부터 팬 조립품을 제거할 때 팬은 여전히 회전하고 있을 수 있습니다. 팬 조립품 외관의 열려있는 부분들로부터 손가락 및 스크류드라이버, 다른 물체들이 가까이 하지 않도록 배치해 주십시오.

Waarschuwing

Gevaarlijk bewegende onderdelen. Houd voldoende afstand tot de bewegende ventilatorbladen. Het is mogelijk dat de ventilator nog draait tijdens het verwijderen van het ventilatorsamenstel uit het chassis. Houd uw vingers, schroevendraaiers en eventuele andere voorwerpen uit de buurt van de openingen in de ventilatorbehuizing.

Power Cable and AC Adapter



Warning! When installing the product, use the provided or designated connection cables, power cables and AC adaptors. Using any other cables and adaptors could cause a malfunction or a fire. Electrical Appliance and Material Safety Law prohibits the use of UL or CSA -certified cables (that have UL/CSA shown on the cord) for any other electrical devices than products designated by Supermicro only.

電源コードとACアダプター

製品を設置する場合、提供または指定および購入された接続ケーブル、電源コードとACアダプターを該当する地域の条例や安全基準に適合するコードサイズやプラグと共に使用下さい。他のケーブルやアダプタを使用すると故障や火災の原因になることがあります。

電気用品安全法は、ULまたはCSA認定のケーブル(UL/CSAマークがコードに表記)を Supermicro が指定する製品以外に使用することを禁止しています。

警告

安装此产品时,请使用本身提供的或指定的或采购的连接线,电源线和电源适配器。包含遵照当地法规和安全要求的合规的电源线尺寸和插头。使用其它线材或适配器可能会引起故障或火灾。除了Supermicro所指定的产品,电气用品和材料安全法律规定禁止使用未经UL或CSA认证的线材。(线材上会显示UL/CSA符号)。

警告

安裝此產品時,請使用本身提供的或指定的或採購的連接線,電源線和電源適配器。包含遵照當地法規和安全要求的合規的電源線尺寸和插頭。使用其它線材或適配器可能會引起故障或火災。除了Supermicro所指定的產品,電氣用品和材料安全法律規定禁止使用未經UL或CSA認證的線材。(線材上會顯示UL/CSA符號)。

Warnung

Nutzen Sie beim Installieren des Produkts ausschließlich die von uns zur Verfügung gestellten Verbindungskabeln, Stromkabeln und/oder Adapter, die Ihre örtlichen Sicherheitsstandards einhalten. Der Gebrauch von anderen Kabeln und Adapter können Fehlfunktionen oder Feuer verursachen. Die Richtlinien untersagen das Nutzen von UL oder CAS zertifizierten Kabeln (mit UL/CSA gekennzeichnet), an Geräten oder Produkten die nicht mit Supermicro gekennzeichnet sind.

¡Advertencia!

Cuando instale el producto, utilice la conexión provista o designada o procure cables, Cables de alimentación y adaptadores de CA que cumplan con los códigos locales y los requisitos de seguridad, incluyendo el tamaño adecuado del cable y el enchufe. El uso de otros cables y adaptadores podría causar un mal funcionamiento o un incendio. La Ley de Seguridad de Aparatos Eléctricos y de Materiales prohíbe El uso de cables certificados por UL o CSA (que tienen el certificado UL / CSA en el código) para cualquier otros dispositivos eléctricos que los productos designados únicamente por Supermicro.

Attention

Lors de l'installation du produit, utilisez les cables de connection fournis ou désigné ou achetez des cables, cables de puissance et adaptateurs respectant les normes locales et les conditions de securite y compris les tailles de cables et les prises electriques appropriées. L'utilisation d'autres cables et adaptateurs peut provoquer un dysfonctionnement ou un incendie. Appareils électroménagers et la Loi sur la Sécurité Matériel interdit l'utilisation de câbles certifiés- UL ou CSA (qui ont UL ou CSA indiqué sur le code) pour tous les autres appareils électriques sauf les produits désignés par Supermicro seulement.

AC ימאתמו מילמשח מילבכ

!הרהזא

ךרוצל ומאתוה וא ושכרנ רשא AC מילמשח מילבכ, מילבכב שמתשהל שי, רצומה תא מיניקתמ רשאכ לכב שומיש . עקתהו לבכה לש הנוכח הדימ ללוכ, תוימוקמה תוחיטבה תושירדל ומאתוה רשאו, הנקתהה למשחה ירישכמב שומישה יקוחל מאתהב. ילמשח רצק וא הלקתל מורגל לולע, רחא גוסמ מאתמ וא לבכ לש דוק מהילע עיפומ רשאכ) UL-ב או CSA-ב -ב מיכמומה מילבכב שמתשהל רוסיא מייק, תוחיטבה יקוחו דבלב Supermicro י"ע מאתוה רשא רצומב קר אלא, רחא ילמשח רצומ לכ רובע (UL/CSA)

תאלבאלא אארשב מץ וא אדדחמלא וא ארפוטמלא תאלויסוטלא מאדחטסאב מץ, אגתנמלא בייקרת דנע לכלז יפ אמב אילחמלא אלאסלא תאבלטתמו נינאווקב מאזתלאלא אג דדרתמלא ראיטלא תאלוחמו אילברמלא קיירח וא לטע יפ בבסטטי דץ ירשא תאלוחמו תאלבאלא יא מאדחטסא. מילסלא סבאלאו ולסומלא מץ ח. CSA וא UL לבק נמ אדמטעמלא תאלבאלא מאדחטסא תאדעמלא אילברמלא אזהאלל אלאסלא נונאק רזחיי Supermicro לבק נמ אדדחמלא אילחמלא תאגתנמלא רייג ירשא תאדעמ יא אג (UL/CSA) אלאע למחתי יתלאו

전원 케이블 및 AC 어댑터

경고! 제품을 설치할 때 현지 코드 및 적절한 굵기의 코드와 플러그를 포함한 안전 요구 사항을 준수하여 제공되거나 지정된 연결 혹은 구매 케이블, 전원 케이블 및 AC 어댑터를 사용하십시오.

다른 케이블이나 어댑터를 사용하면 오작동이나 화재가 발생할 수 있습니다. 전기 용품 안전법은 UL 또는 CSA 인증 케이블 (코드에 UL / CSA가 표시된 케이블)을 Supermicro가 지정한 제품 이외의 전기 장치에 사용하는 것을 금지합니다.

Stroomkabel en AC-Adapter

Waarschuwing! Bij het aansluiten van het Product uitsluitend gebruik maken van de geleverde Kabels of een andere geschikte aan te schaffen Aansluitmethode, deze moet altijd voldoen aan de lokale voorschriften en veiligheidsnormen, inclusief de juiste kabeldikte en stekker. Het gebruik van niet geschikte Kabels en/of Adapters kan een storing of brand veroorzaken. Wetgeving voor Elektrische apparatuur en Materiaalveiligheid verbied het gebruik van UL of CSA -gecertificeerde Kabels (met UL/CSA in de code) voor elke andere toepassing dan de door Supermicro hiervoor beoogde Producten.

Appendix B

System Specifications

Processors

Supports dual 4th/5th Gen. Intel Xeon Scalable (in Socket E LGA 4677) with four UPIs (20 GT/s max.) with up to 64 cores and a Thermal Design Power (TDP) of up to 385 W

Chipset

Intel C741

BIOS

256 Mb AMI BIOS® SPI Flash BIOS

ACPI 6.0, Plug and Play (PnP), BIOS rescue hot-key, riser card auto detection support, and SMBIOS 3.0 or later

Memory

Supports up to 8 TB of 3DS RDIMM/RDIMM DDR5 (288-pin) ECC memory with speeds of up to 5600 MT/s (1DPC) in 32 DIMM slots

Note: Memory speed and capacity support depends on the processor.

GPU Support

HGX H100 4-GPU SXM5 Multi-GPU Board PCIe 5.0 x16 CPU-to-GPU Interconnect, NVIDIA NVLink with NVSwitch (up to 700 W)

Storage Drives

Four hot-swap 2.5" bays (SATA/NVMe Hybrid or SAS with optional HBA, SSDs only)

PCI Expansion Slots

Four low-profile x16 PCIe 5.0 slots

Two onboard M.2 slots in the 22110/2280 form factor

Input/Output

Via the I/O board AOM-PTG-I2T:

- Two 10 G Ethernet LAN ports
- One dedicated BMC LAN port
- Two USB ports
- One VGA port

Motherboard

X13DEG-R

Chassis

CSE-228G2TS-R5K25P; 2U rackmount, (WxHxD) 17.2 x 3.5 x 32.7 in (437 x 89 x 830.3 mm)

System Cooling

Four hot-swap 80-mm, counter-rotating PWM fans; one air shroud, liquid-cooled CPU and GPU

Power Supply

SYS-221GE-TNHT-LC1: PWS-5K25G-2R, two 5250 W (1+1) Titanium Level efficiency power supplies (80 Plus)

AC Input:

- 2880 W: 200-207 Vac, 16-15.7 A, 50-60 Hz
- 3000 W: 207.1-240 Vac, 16-14.5 A, 50-60 Hz
- 3000 W: 240 Vdc, 15 A

DC Output:

- +54 V, 45 A
- +12 V, 91.66 A
- +12 Vsb, 3 A

+12 V:

- Max: 91.66 A / Min: 0 A (200-240 Vdc)

12 Vsb:

- Max: 3 A / Min: 0 A

Operating Environment

Operating Temperature: 10° to 35° C (50° to 95° F)

Non-operating Temperature: -40° to 60° C (-40° to 140° F)

Operating Relative Humidity: 8% to 90% (non-condensing)

Non-operating Relative Humidity: 5% to 95% (non-condensing)

Regulatory Compliance

FCC, ICES, CE, VCCI, RCM, UKCA, NRTL, CB

Applied Directives, Standards

EMC/EMI: 2014/30/EU (EMC Directive)

Electromagnetic Compatibility Regulations 2016

FCC Part 15 Subpart B

ICES-003

VCCI-CISPR 32

AS/NZS CISPR 32

BS/EN 55032

BS/EN 55035

CISPR 32

BS/EN 61000-3-2

BS/EN 61000-3-3

BS/EN 61000-4-2

BS/EN 61000-4-3

BS/EN 61000-4-4

BS/EN 61000-4-5

BS/EN 61000-4-6

BS/EN 61000-4-8

BS/EN 61000-4-11

Environment:

Delegated Directive (EU) 2015/863

Directive 2011/65/EU (RoHS)

REACH Regulation EC 1907/2006

WEEE Directive 2012/19/EU

California Proposition 65

Product Safety: 2014/35/EU (LVD Directive)

UL/CSA 62368-1 (USA and Canada)

Electromagnetic Equipment (Safety) Regulations 2016

IEC/BS/EN 62368-1

Perchlorate Warning

California Best Management Practices Regulations for Perchlorate Materials: This Perchlorate warning applies only to products containing CR (Manganese Dioxide) Lithium coin cells. "Perchlorate Material-special handling may apply. See www.dtsc.ca.gov/hazardouswaste/perchlorate"

この装置は、クラスA機器です。この装置を住宅環境で使用すると電波妨害を引き起こすことがあります。この場合には使用者が適切な対策を講ずるよう要求されることがあります。

VCCI — A