

SUPERO[®]

SUPER STORAGE SYSTEM

6027R-E1CR12N

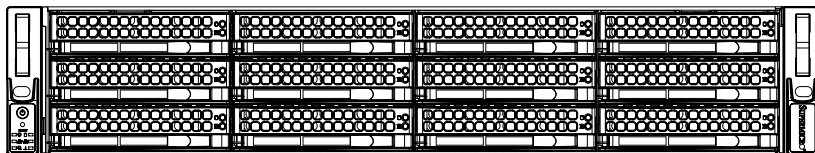

USER'S MANUAL

1.0a

The information in this User's Manual has been carefully reviewed and is believed to be accurate. The vendor assumes no responsibility for any inaccuracies that may be contained in this document, makes no commitment to update or to keep current the information in this manual, or to notify any person or organization of the updates. **Please Note: For the most up-to-date version of this manual, please see our web site at www.supermicro.com.**

Super Micro Computer, Inc. ("Supermicro") reserves the right to make changes to the product described in this manual at any time and without notice. This product, including software and documentation, is the property of Supermicro and/or its licensors, and is supplied only under a license. Any use or reproduction of this product is not allowed, except as expressly permitted by the terms of said license.

IN NO EVENT WILL SUPERMICRO BE LIABLE FOR DIRECT, INDIRECT, SPECIAL, INCIDENTAL, SPECULATIVE OR CONSEQUENTIAL DAMAGES ARISING FROM THE USE OR INABILITY TO USE THIS PRODUCT OR DOCUMENTATION, EVEN IF ADVISED OF THE POSSIBILITY OF SUCH DAMAGES. IN PARTICULAR, SUPERMICRO SHALL NOT HAVE LIABILITY FOR ANY HARDWARE, SOFTWARE, OR DATA STORED OR USED WITH THE PRODUCT, INCLUDING THE COSTS OF REPAIRING, REPLACING, INTEGRATING, INSTALLING OR RECOVERING SUCH HARDWARE, SOFTWARE, OR DATA.

Any disputes arising between manufacturer and customer shall be governed by the laws of Santa Clara County in the State of California, USA. The State of California, County of Santa Clara shall be the exclusive venue for the resolution of any such disputes. Super Micro's total liability for all claims will not exceed the price paid for the hardware product.

FCC Statement: This equipment has been tested and found to comply with the limits for a Class A digital device pursuant to Part 15 of the FCC Rules. These limits are designed to provide reasonable protection against harmful interference when the equipment is operated in a commercial environment. This equipment generates, uses, and can radiate radio frequency energy and, if not installed and used in accordance with the manufacturer's instruction manual, may cause harmful interference with radio communications. Operation of this equipment in a residential area is likely to cause harmful interference, in which case you will be required to correct the interference at your own expense.

California Best Management Practices Regulations for Perchlorate Materials: This Perchlorate warning applies only to products containing CR (Manganese Dioxide) Lithium coin cells. "Perchlorate Material-special handling may apply. See www.dtsc.ca.gov/hazardouswaste/perchlorate"

WARNING: Handling of lead solder materials used in this product may expose you to lead, a chemical known to the State of California to cause birth defects and other reproductive harm.

Manual Revision 1.0a
Release Date: February 22, 2016

Unless you request and receive written permission from Super Micro Computer, Inc., you may not copy any part of this document.

Information in this document is subject to change without notice. Other products and companies referred to herein are trademarks or registered trademarks of their respective companies or mark holders.

Copyright © 2016 by Super Micro Computer, Inc.
All rights reserved.
Printed in the United States of America

Preface

About This Manual

This manual is written for professional system integrators and PC technicians. It provides information for the installation and use of the 6027R-E1CR12N. Installation and maintenance should be performed by experienced technicians only.

The 6027R-E1CR12N is a high-end storage system based on the SC826BE1C-R920LP 2U rackmountable chassis and the X9DRi-LN4F+ dual processor serverboard.

Manual Organization

Chapter 1: Introduction

The first chapter provides a checklist of the main components included with the system and describes the main features of the X9DRi-LN4F+ serverboard and the SC826BE1C-R920LP chassis.

Chapter 2: Server Installation

This chapter describes the steps necessary to install the 6027R-E1CR12N into a rack and check out the server configuration prior to powering up the system. If your server was ordered without processor and memory components, this chapter will refer you to the appropriate sections of the manual for their installation.

Chapter 3: System Interface

Refer here for details on the system interface, which includes the functions and information provided by the control panel on the chassis as well as other LEDs located throughout the system.

Chapter 4: Standardized Safety Warnings

You should thoroughly familiarize yourself with this chapter for a general overview of safety precautions that should be followed when installing and servicing the 6027R-E1CR12N.

Chapter 5: Advanced Serverboard Setup

Chapter 5 provides detailed information on the X9DRI-LN4F+ serverboard, including the locations and functions of connections, headers and jumpers. Refer to this chapter when adding or removing processors or main memory and when reconfiguring the serverboard.

Chapter 6: Advanced Chassis Setup

Refer to Chapter 6 for detailed information on the SC826BE1C-R920LP chassis. You should follow the procedures given in this chapter when installing, removing or reconfiguring SATA or peripheral drives and when replacing system power supply units and cooling fans.

Chapter 7: BIOS

The BIOS chapter includes an introduction to BIOS and provides detailed information on running the CMOS Setup Utility.

Appendix A: BIOS Error Beep Codes**Appendix B: System Specifications****Notes**

Table of Contents

Chapter 1 Introduction

| | | |
|-----|-------------------------------|-----|
| 1-1 | Overview | 1-1 |
| 1-2 | Serverboard Features | 1-2 |
| | Processors | 1-2 |
| | Memory | 1-2 |
| | SAS | 1-2 |
| | Serial ATA | 1-2 |
| | PCI Expansion Slots | 1-2 |
| | Rear I/O Ports | 1-3 |
| 1-3 | Server Chassis Features | 1-3 |
| | System Power | 1-3 |
| | Hard Drive Subsystem | 1-3 |
| | Front Control Panel | 1-3 |
| | Cooling System | 1-3 |
| 1-4 | Contacting Supermicro | 1-6 |

Chapter 2 Server Installation

| | | |
|-----|---|-----|
| 2-1 | Overview | 2-1 |
| 2-2 | Unpacking the System | 2-1 |
| 2-3 | Preparing for Setup | 2-1 |
| | Choosing a Setup Location | 2-1 |
| 2-4 | Warnings and Precautions | 2-2 |
| | Rack Precautions | 2-2 |
| | Server Precautions | 2-2 |
| | Rack Mounting Considerations | 2-3 |
| 2-5 | Installing the System into a Rack | 2-4 |
| | Separating the Sections of the Rack Rails | 2-4 |
| | Installing the Inner Rail Extension | 2-4 |
| | Outer Rack Rails | 2-6 |

Chapter 3 System Interface

| | | |
|-----|-----------------------------|-----|
| 3-1 | Overview | 3-1 |
| 3-2 | Control Panel Buttons | 3-1 |
| | Reset | 3-1 |
| | Power | 3-1 |
| 3-3 | Control Panel LEDs | 3-2 |
| | Power Fail | 3-2 |
| | Overheat/Fan Fail: | 3-2 |

| | | |
|-----|--------------------------|-----|
| | NIC1 | 3-2 |
| | NIC2 | 3-2 |
| | HDD | 3-3 |
| | Power | 3-3 |
| 3-4 | Drive Carrier LEDs | 3-3 |

Chapter 4 Standardized Warning Statements for AC Systems

| | | |
|-----|---|------|
| 4-1 | About Standardized Warning Statements | 4-1 |
| | Warning Definition | 4-1 |
| | Installation Instructions | 4-4 |
| | Circuit Breaker | 4-5 |
| | Power Disconnection Warning | 4-6 |
| | Equipment Installation | 4-8 |
| | Restricted Area | 4-9 |
| | Battery Handling | 4-10 |
| | Redundant Power Supplies | 4-12 |
| | Backplane Voltage | 4-13 |
| | Comply with Local and National Electrical Codes | 4-14 |
| | Product Disposal | 4-15 |
| | Hot Swap Fan Warning | 4-16 |
| | Power Cable and AC Adapter | 4-18 |

Chapter 5 Advanced Serverboard Setup

| | | |
|-----|---|------|
| 5-1 | Handling the Serverboard | 5-1 |
| | Precautions | 5-1 |
| | Unpacking | 5-2 |
| 5-2 | Connecting Cables | 5-2 |
| | Connecting Data Cables | 5-2 |
| | Connecting Power Cables | 5-2 |
| | Connecting the Control Panel | 5-2 |
| 5-3 | Rear I/O Ports | 5-3 |
| 5-4 | Installing the Processor and Heatsink | 5-4 |
| | Installing an LGA2011 Processor | 5-4 |
| | Installing a Passive CPU Heatsink | 5-7 |
| | Removing the Heatsink | 5-8 |
| 5-5 | Installing Memory | 5-9 |
| | Memory Support | 5-9 |
| | DIMM Installation | 5-9 |
| 5-6 | Adding PCI Add-On Cards | 5-14 |
| 5-7 | Serverboard Details | 5-15 |

| | | |
|------|----------------------------------|------|
| | X9DRI-LN4F+ Quick Reference..... | 5-16 |
| 5-8 | Connector Definitions | 5-18 |
| 5-9 | Jumper Settings | 5-25 |
| 5-10 | Onboard Indicators..... | 5-29 |
| 5-11 | SATA Ports | 5-30 |
| 5-12 | Installing Software..... | 5-31 |
| | SuperDoctor III | 5-32 |

Chapter 6 Advanced Chassis Setup

| | | |
|-----|--|------|
| 6-1 | Static-Sensitive Devices..... | 6-1 |
| | Precautions | 6-1 |
| | Unpacking | 6-1 |
| 6-2 | Control Panel | 6-2 |
| 6-3 | Accessing the Inside of the Chassis..... | 6-2 |
| 6-4 | System Fans | 6-3 |
| | System Fan Failure..... | 6-3 |
| | Replacing System Fans | 6-4 |
| 6-5 | Air Shroud | 6-5 |
| 6-6 | Drive Bay Installation/Removal | 6-6 |
| | Accessing the Drive Bays | 6-6 |
| | SAS/SATA Drive Installation..... | 6-6 |
| | Hard Drive Backplane | 6-8 |
| 6-7 | Power Supply..... | 6-9 |
| | Power Supply Failure..... | 6-9 |
| | Removing/Replacing the Power Supply..... | 6-9 |
| 6-8 | Attaching a JBOD Expansion Chassis..... | 6-11 |

Chapter 7 BIOS

| | | |
|-----|------------------------------------|------|
| 7-1 | Introduction..... | 7-1 |
| 7-2 | Main Setup..... | 7-2 |
| 7-3 | Advanced Setup Configurations..... | 7-3 |
| 7-4 | Event Logs | 7-23 |
| 7-5 | IPMI..... | 7-26 |
| 7-6 | Boot..... | 7-28 |
| 7-7 | Security..... | 7-29 |
| 7-8 | Save & Exit | 7-30 |

Appendix A BIOS Error Beep Codes

Appendix B System Specifications

Chapter 1

Introduction

1-1 Overview

The 6027R-E1CR12N is a high-end storage system comprised of two main subsystems: the SC826BE1C-R920LP 2U/rack mount chassis and the X9DRi-LN4F+ dual processor serverboard. Please refer to our web site for information on operating systems that have been certified for use with the system (www.supermicro.com).

In addition to the serverboard and chassis, various hardware components have been included with the 6027R-E1CR12N, as listed below:

- Two passive CPU heatsinks (SNK-P0048P)
- Three 8-cm system fans (FAN-0126L4)
- One air shroud (MCP-310-29001-0N)
- SATA Accessories
 - One SATA backplane (BPN-SAS3-826EL1)
 - Twelve drive carriers (MCP-220-00075-OB)
- Hardware RAID Controller (AOC-S3108L-H8IR)
- JBOD Expansion Port (AOM-SAS3-8I8E-LP)
- One rackmount kit (MCP-290-00053-0N)

Note: For your system to work properly, please follow the links below to download all necessary drivers/utilities and the user's manual for your server.

- Supermicro product manuals: <http://www.supermicro.com/support/manuals/>
- Product drivers and utilities: <ftp://ftp.supermicro.com>
- Product safety info: http://www.supermicro.com/about/policies/safety_information.cfm

1-2 Serverboard Features

The 6027R-E1CR12N is built around the X9DRi-LN4F+, a dual processor serverboard based on the Intel C600 chipset and designed to provide maximum performance. Below are the main features of the X9DRi-LN4F+. (See Figure 1-1 for a block diagram of the chipset).

Processors

The X9DRi-LN4F+ supports single or dual Intel® Xeon E5-2600 Series processors. Please refer to the serverboard description pages on our web site for a complete listing of supported processors (www.supermicro.com).

Memory

The X9DRi-LN4F+ has 24 DIMM slots that can support up to 1.5 TB of LRDIMM (Load Reduced DIMM), 768 GB of RDIMM (Registered DIMMs) or 128 GB of UDIMM (Unbuffered DIMMs) ECC/Non-ECC DDR3-1866/1600/1333/1066/800 SDRAM. See Chapter 5 for details.

SAS

An LSI 3108 controller card is included in the system to support 240 SAS3/SATA3 hard drives. (RAID 0, 1, 5, 6, 10, 50 and 60 supported). The SAS/SATA drives are hot-swappable units.

Serial ATA

A SATA controller is also integrated into the chipset to provide two SATA 3 (6/Gbps) and four SATA 2 (3 Gbps) ports, which are RAID 0, 1, 5 and 10 supported. The SATA drives are hot-swappable units. RAID 5 supported with Windows OS only).

Note: The operating system you use must have RAID support to enable the hot-swap capability and RAID function of the SATA drives.

PCI Expansion Slots

The X9DRi-LN4F+ has four PCI-E 3.0 x16 slots, one PCI-E 3.0 x8 slot and one PCI-E 3.0 x4 (in a x8) slot. The default configuration includes an add-on card (AOC) populating Slot #1 (PCI-E 3.0 x 16 slot) and a port plate with a JBOD expansion port occupying slot #2 (PCI-E 3.0 x4).

Rear I/O Ports

The color-coded I/O ports include one COM port, a VGA port, four USB 2.0 ports (additional USB headers are included on the serverboard), four gigabit Ethernet ports and two external MiniSAS JBOD expansion port. A dedicated IPMI LAN port is also included.

1-3 Server Chassis Features

The SC826BE1C-R920LP is an 2U form factor chassis designed to be used in a storage configuration. The following is a general outline of the main features of the SC826BE1C-R920LP chassis.

System Power

The SC826BE1C-R920LP features a redundant, hot-plug 920W power supply composed of two separate power modules. This power redundancy feature allows you to replace a failed power supply without shutting down the system.

Hard Drive Subsystem

The SC826BE1C-R920LP chassis was designed to support 12 hot-swap SATA hard drives. An optional, internal fixed drive mounting bracket (MCP-220-82611-0N) may be added to support two 2.5" SATA drives.

Front Control Panel

The control panel on the SC826BE1C-R920LP provides you with system monitoring and control. LEDs indicate system power, HDD activity, network activity, system overheat and power supply failure. A main power button and a system reset button are also included.

Cooling System

The SC826BE1C-R920LP chassis includes three 8-cm hot-plug system cooling fans located in the middle section of the chassis. An air shroud channels the airflow from the system fans to efficiently cool the processor area of the system. Each power supply module also includes a cooling fan.

**Figure 1-1. Intel C600 Chipset:
System Block Diagram**

Note: This is a general block diagram. Please see Chapter 5 for details.

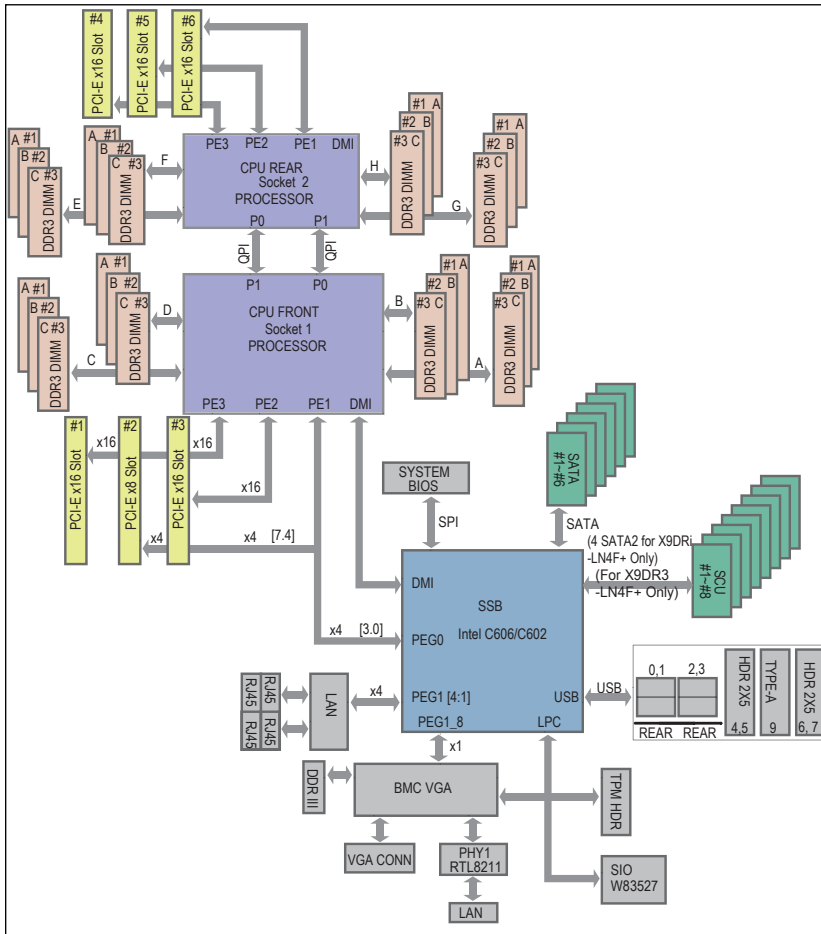
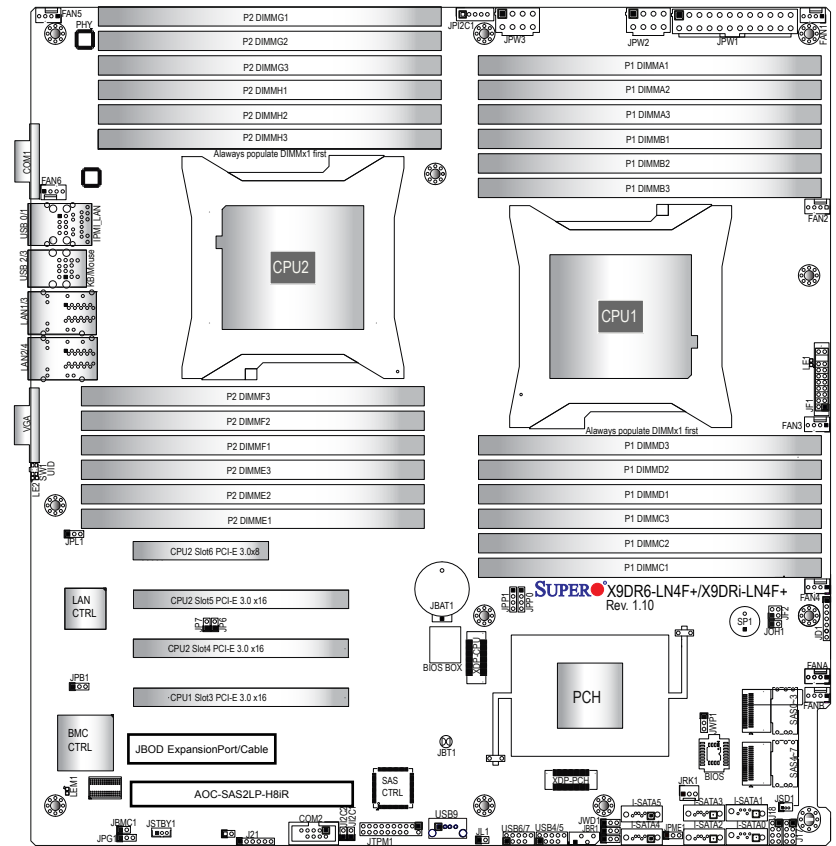

Figure 1-2. X9DRi-LN4F+ Serverboard



Note: The SSG-6027R-E1CR12N comes pre-installed with a Hardware RAID controller installed in PCI-E slot 1 and a JBOD expansion port installed in PCI-E slot 2. Serverboard SAS components shown in the figure above are not included on the X9DRi-LN4F+

1-4 Contacting Supermicro

Headquarters

Address: Super Micro Computer, Inc.
980 Rock Ave.
San Jose, CA 95131 U.S.A.

Tel: +1 (408) 503-8000

Fax: +1 (408) 503-8008

Email: marketing@supermicro.com (General Information)
support@supermicro.com (Technical Support)

Website: www.supermicro.com

Europe

Address: Super Micro Computer B.V.
Het Sterrenbeeld 28, 5215 ML
's-Hertogenbosch, The Netherlands

Tel: +31 (0) 73-6400390

Fax: +31 (0) 73-6416525

Email: sales@supermicro.nl (General Information)
support@supermicro.nl (Technical Support)
rma@supermicro.nl (Customer Support)

Website: www.supermicro.nl

Asia-Pacific

Address: Super Micro Computer, Inc.
3F, No. 150, Jian 1st Rd.
Zhonghe Dist., New Taipei City 235
Taiwan (R.O.C)

Tel: +886-(2) 8226-3990

Fax: +886-(2) 8226-3992

Email: support@supermicro.com.tw

Website: www.supermicro.com.tw

Chapter 2

Server Installation

2-1 Overview

This chapter provides a quick setup checklist to get your 6027R-E1CR12N up and running. Following these steps in the order given should enable you to have the system operational within a minimum amount of time. This quick setup assumes that your system has come to you with the processors and memory preinstalled. If your system is not already fully integrated with a serverboard, processors, system memory etc., please turn to the chapter or section noted in each step for details on installing specific components.

2-2 Unpacking the System

You should inspect the box the 6027R-E1CR12N was shipped in and note if it was damaged in any way. If the server itself shows damage you should file a damage claim with the carrier who delivered it.

Decide on a suitable location for the rack unit that will hold the 6027R-E1CR12N. It should be situated in a clean, dust-free area that is well ventilated. Avoid areas where heat, electrical noise and electromagnetic fields are generated. You will also need it placed near a grounded power outlet. Read the Rack and Server Precautions in the next section.

2-3 Preparing for Setup

The box the 6027R-E1CR12N was shipped in should include two sets of rail assemblies, two rail mounting brackets and the mounting screws you will need to install the system into the rack. Follow the steps in the order given to complete the installation process in a minimum amount of time. Please read this section in its entirety before you begin the installation procedure outlined in the sections that follow.

Choosing a Setup Location

- Leave enough clearance in front of the rack to enable you to open the front door completely (~25 inches) and approximately 30 inches of clearance in the back of the rack to allow for sufficient airflow and ease in servicing.

- This product is for installation only in a Restricted Access Location (dedicated equipment rooms, service closets and the like).
- This product is not suitable for use with visual display work place devices according to §2 of the the German Ordinance for Work with Visual Display Units.

2-4 Warnings and Precautions

Rack Precautions

- Ensure that the leveling jacks on the bottom of the rack are fully extended to the floor with the full weight of the rack resting on them.
- In single rack installation, stabilizers should be attached to the rack. In multiple rack installations, the racks should be coupled together.
- Always make sure the rack is stable before extending a component from the rack.
- You should extend only one component at a time - extending two or more simultaneously may cause the rack to become unstable.

Server Precautions

- Review the electrical and general safety precautions in Chapter 4.
- Determine the placement of each component in the rack *before* you install the rails.
- Install the heaviest server components on the bottom of the rack first, and then work up.
- Use a regulating uninterruptible power supply (UPS) to protect the server from power surges, voltage spikes and to keep your system operating in case of a power failure.
- Allow any hot plug drives and power supply modules to cool before touching them.
- Always keep the rack's front door and all panels and components on the servers closed when not servicing to maintain proper cooling.

Rack Mounting Considerations

Ambient Operating Temperature

If installed in a closed or multi-unit rack assembly, the ambient operating temperature of the rack environment may be greater than the ambient temperature of the room. Therefore, consideration should be given to installing the equipment in an environment compatible with the manufacturer's maximum rated ambient temperature (T_{mra}).

Reduced Airflow

Equipment should be mounted into a rack so that the amount of airflow required for safe operation is not compromised.

Mechanical Loading

Equipment should be mounted into a rack so that a hazardous condition does not arise due to uneven mechanical loading.

Circuit Overloading

Consideration should be given to the connection of the equipment to the power supply circuitry and the effect that any possible overloading of circuits might have on overcurrent protection and power supply wiring. Appropriate consideration of equipment nameplate ratings should be used when addressing this concern.

Reliable Ground

A reliable ground must be maintained at all times. To ensure this, the rack itself should be grounded. Particular attention should be given to power supply connections other than the direct connections to the branch circuit (i.e. the use of power strips, etc.).



Warning! To prevent bodily injury when mounting or servicing this unit in a rack, you must take special precautions to ensure that the system remains stable. The following guidelines are provided to ensure your safety:

- This unit should be mounted at the bottom of the rack if it is the only unit in the rack.
- When mounting this unit in a partially filled rack, load the rack from the bottom to the top with the heaviest component at the bottom of the rack.
- If the rack is provided with stabilizing devices, install the stabilizers before mounting or servicing the unit in the rack.

2-5 Installing the System into a Rack

This section provides information on installing the SC826 chassis into a rack unit with the quick-release rails provided. There are a variety of rack units on the market, which may mean the assembly procedure will differ slightly. You should also refer to the installation instructions that came with the rack unit you are using.

Separating the Sections of the Rack Rails

The chassis package includes two rail assemblies in the rack mounting kit. Each assembly consists of two sections: an inner fixed chassis rail that secures directly to the server chassis and an outer fixed rack rail that secures directly to the rack itself.

Installing the Inner Rail Extension

The SC826 chassis includes a set of inner rails in two sections: inner rails and inner rail extensions. The inner rails are pre-attached to the chassis, and do not interfere with normal use of the chassis if you decide not to use a server rack. The inner rail extension is attached to the inner rail to mount the chassis in the rack.

Installing the Inner Rails

1. Place the inner rail extensions on the side of the chassis aligning the hooks of the chassis with the rail extension holes. Make sure the extension faces "outward" just like the pre-attached inner rail.
2. Slide the extension toward the front of the chassis.
3. Secure the chassis with 2 screws as illustrated. Repeat steps for the other inner rail extension.



Warning: do not pick up the server with the front handles. They are designed to pull the system from a rack only.

Figure 2-1. Separating the Rack Rails

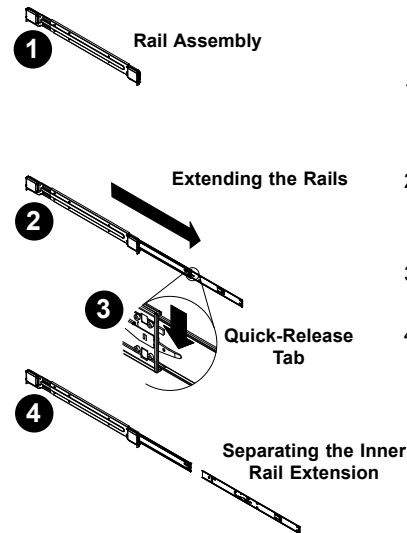

Separating the Inner and Outer Rails

1. Locate the rail assembly in the chassis packaging.
2. Extend the rail assembly by pulling it outward.
3. Press the quick-release tab.
4. Separate the inner rail extension from the outer rail assembly.



Slide rail mounted equipment is not to be used as a shelf or a work space.



Stability hazard. The rack stabilizing mechanism must be in place, or the rack must be bolted to the floor before you slide the unit out for servicing. Failure to stabilize the rack can cause the rack to tip over.

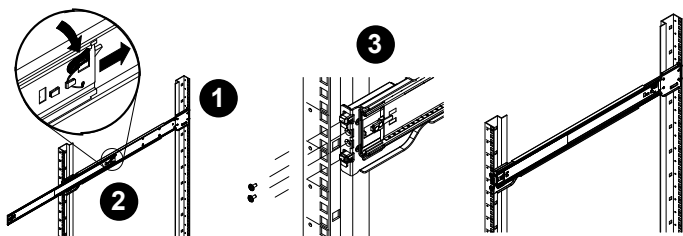

Figure 2-2. Assembling the Outer Rails

Outer Rack Rails

Outer rails attach to the rack and hold the chassis in place. The outer rails for the SC826 chassis extend between 30 inches and 33 inches.

Installing the Outer Rails to the Rack

1. Secure the back end of the outer rail to the rack, using the screws provided.
2. Press the button where the two outer rails are joined to retract the smaller outer rail.
3. Hang the hooks of the rails onto the rack holes and if desired, use screws to secure the front of the outer rail onto the rack.
4. Repeat steps 1-3 for the remaining outer rail.

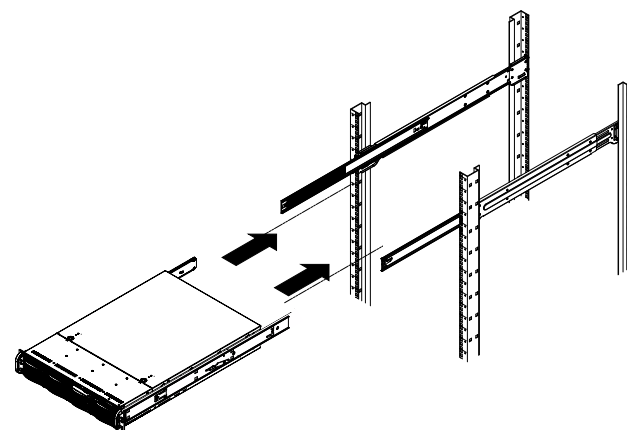

Figure 2-3. Installing the Rack Rails

Installing the Chassis into a Rack

1. Extend the outer rails as illustrated above.
2. Align the inner rails of the chassis with the outer rails on the rack.
3. Slide the inner rails into the outer rails, keeping the pressure even on both sides. When the chassis has been pushed completely into the rack, it should click into the locked position.
4. Optional screws may be used to secure the to hold the front of the chassis to the rack.

Note: The figure above is for illustration purposes only. Always install servers to the bottom of the rack first.

Notes

Chapter 3

System Interface

3-1 Overview

There are several LEDs on the control panel as well as others on the drive carriers to keep you constantly informed of the overall status of the system as well as the activity and health of specific components. There are also two buttons on the chassis control panel.

3-2 Control Panel Buttons

There are two buttons located on the front of the chassis: a reset button and a power on/off button.

RESET



Reset

Use the reset button to reboot the system.



Power

This is the main power button, which is used to apply or turn off the main system power. Turning off system power with this button removes the main power but keeps standby power supplied to the system.

3-3 Control Panel LEDs

The control panel located on the front of the chassis has several LEDs. These LEDs provide you with critical information related to different parts of the system. This section explains what each LED indicates when illuminated and any corrective action you may need to take.



Power Fail

Indicates a power supply module has failed. The second power supply module will take the load and keep the system running but the failed module will need to be replaced. Refer to Chapter 6 for details on replacing the power supply. This LED should be off when the system is operating normally.



Overheat/Fan Fail:

When this LED flashes, it indicates a fan failure. When on continuously it indicates an overheat condition, which may be caused by cables obstructing the airflow in the system or the ambient room temperature being too warm. Check the routing of the cables and make sure all fans are present and operating normally. You should also check to make sure that the chassis covers are installed. Finally, verify that the heatsinks are installed properly (see Chapter 5). This LED will remain flashing or on as long as the indicated condition exists.



NIC1

Indicates network activity on the LAN1 port when flashing.



NIC2

Indicates network activity on the LAN2 port when flashing.



HDD

On the 6027R-E1CR12N, this LED indicates hard drive activity when flashing.



Power

Indicates power is being supplied to the system's power supply units. This LED should normally be illuminated when the system is operating.

3-4 Drive Carrier LEDs

Each drive carrier has two LEDs:

SATA Drives

- **Green:** When illuminated, the green LED on the drive carrier indicates drive activity. A connection to the SAS/SATA backplane enables this LED to blink on and off when that particular drive is being accessed. Please refer to Chapter 6 for instructions on replacing failed hard drives.
- **Red:** When this LED flashes it indicates the drive is rebuilding. When solid on it indicates a drive failure. If a drive fails, you should be notified by your system management software. Please refer to Chapter 6 for instructions on replacing failed drives.

Notes

Chapter 4

Standardized Warning Statements for AC Systems

4-1 About Standardized Warning Statements

The following statements are industry standard warnings, provided to warn the user of situations which have the potential for bodily injury. Should you have questions or experience difficulty, contact Supermicro's Technical Support department for assistance. Only certified technicians should attempt to install or configure components.

Read this appendix in its entirety before installing or configuring components in the Supermicro chassis.

These warnings may also be found on our web site at http://www.supermicro.com/about/policies/safety_information.cfm.

Warning Definition



Warning!

This warning symbol means danger. You are in a situation that could cause bodily injury. Before you work on any equipment, be aware of the hazards involved with electrical circuitry and be familiar with standard practices for preventing accidents.

警告の定義

この警告サインは危険を意味します。

人身事故につながる可能性がありますので、いずれの機器でも動作させる前に、電気回路に含まれる危険性に注意して、標準的な事故防止策に精通して下さい。

此警告符号代表危險。

您正處於可能受到嚴重傷害的工作環境中。在您使用設備開始工作之前，必須充分意識到觸電的危險，並熟練掌握防止事故發生的標準工作程序。請根據每項警告結尾的聲明號碼找到此設備的安全性警告說明的翻譯文本。

此警告符號代表危險。

您正處於可能身體可能會受損傷的工作環境中。在您使用任何設備之前，請注意觸電的危險，並且要熟悉預防事故發生的標準工作程序。請依照每一注意事項後的號碼找到相關的翻譯說明內容。

Warnung**WICHTIGE SICHERHEITSHINWEISE**

Dieses Warnsymbol bedeutet Gefahr. Sie befinden sich in einer Situation, die zu Verletzungen führen kann. Machen Sie sich vor der Arbeit mit Geräten mit den Gefahren elektrischer Schaltungen und den üblichen Verfahren zur Vorbeugung vor Unfällen vertraut. Suchen Sie mit der am Ende jeder Warnung angegebenen Anweisungsnummer nach der jeweiligen Übersetzung in den übersetzten Sicherheitshinweisen, die zusammen mit diesem Gerät ausgeliefert wurden.

BEWAHREN SIE DIESE HINWEISE GUT AUF.

INSTRUCCIONES IMPORTANTES DE SEGURIDAD

Este símbolo de aviso indica peligro. Existe riesgo para su integridad física. Antes de manipular cualquier equipo, considere los riesgos de la corriente eléctrica y familiarícese con los procedimientos estándar de prevención de accidentes. Al final de cada advertencia encontrará el número que le ayudará a encontrar el texto traducido en el apartado de traducciones que acompaña a este dispositivo.

GUARDE ESTAS INSTRUCCIONES.

IMPORTANTES INFORMATIONS DE SÉCURITÉ

Ce symbole d'avertissement indique un danger. Vous vous trouvez dans une situation pouvant entraîner des blessures ou des dommages corporels. Avant de travailler sur un équipement, soyez conscient des dangers liés aux circuits électriques et familiarisez-vous avec les procédures couramment utilisées pour éviter les accidents. Pour prendre connaissance des traductions des avertissements figurant dans les consignes de sécurité traduites qui accompagnent cet appareil, référez-vous au numéro de l'instruction situé à la fin de chaque avertissement.

CONSERVEZ CES INFORMATIONS.

תקנון הצהרות אזהרה

הצהרות הבאות הן אזהרות על פי תקני התעשייה, על מנת להזהיר את המשתמש מפני חבלה פיזית אפשרית. במידה ויש שאלות או היתקלות בבעיה כלשהי, יש ליצור קשר עם מחלקת תמיכה טכנית של סופרמיקרו. טכנאים מוסמכים בלבד רשאים להתקין או להגדיר את הרכיבים.

יש לקרוא את הנספח במלואו לפני התקנת או הגדרת הרכיבים במאזי סופרמיקרו.

تحذير! هذا الرمز يعني خطر انك في حالة يمكن أن تتسبب في اصابة جسدية .
قبل أن تعمل على أي معدات، كن على علم بالمخاطر الناجمة عن الدوائر
الكهربائية

وكن على دراية بالممارسات الوقائية لمنع وقوع أي حوادث
استخدم رقم البيان المنصوص في نهاية كل تحذير للعثور ترجمتها

안전을 위한 주의사항

경고!

이 경고 기호는 위험이 있음을 알려 줍니다. 작업자의 신체에 부상을 야기 할 수 있는 상태에 있게 됩니다. 모든 장비에 대한 작업을 수행하기 전에 전기회로와 관련된 위험요소들을 확인하시고 사전에 사고를 방지할 수 있도록 표준 작업절차를 준수해 주시기 바랍니다.

해당 번역문을 찾기 위해 각 경고의 마지막 부분에 제공된 경고문 번호를 참조하십시오

BELANGRIJKE VEILIGHEIDSINSTRUCTIES

Dit waarschuwings symbool betekent gevaar. U verkeert in een situatie die lichamelijk letsel kan veroorzaken. Voordat u aan enige apparatuur gaat werken, dient u zich bewust te zijn van de bij een elektrische installatie betrokken risico's en dient u op de hoogte te zijn van de standaard procedures om ongelukken te voorkomen. Gebruik de nummers aan het eind van elke waarschuwing om deze te herleiden naar de desbetreffende locatie.

BEWAAR DEZE INSTRUCTIES

Installation Instructions



Warning!

Read the installation instructions before connecting the system to the power source.

設置手順書

システムを電源に接続する前に、設置手順書をお読み下さい。

警告

将此系统连接电源前，请先阅读安装说明。

警告

將系統與電源連接前，請先閱讀安裝說明。

Warnung

Vor dem Anschließen des Systems an die Stromquelle die Installationsanweisungen lesen.

¡Advertencia!

Lea las instrucciones de instalación antes de conectar el sistema a la red de alimentación.

Attention

Avant de brancher le système sur la source d'alimentation, consulter les directives d'installation.

יש לקרוא את הוראות התקנה לפני חיבור המערכת למקור מתח.

اقر إرشادات التركيب قبل توصيل النظام إلى مصدر للطاقة

시스템을 전원에 연결하기 전에 설치 안내를 읽어주시시오.

Waarschuwing

Raadpleeg de installatie-instructies voordat u het systeem op de voedingsbron aansluit.

Circuit Breaker



Warning!

This product relies on the building's installation for short-circuit (overcurrent) protection. Ensure that the protective device is rated not greater than: 250 V, 20 A.

サーキット・ブレーカー

この製品は、短絡(過電流)保護装置がある建物での設置を前提としています。
保護装置の定格が250 V、20 Aを超えないことを確認下さい。

警告

此产品的短路(过载电流)保护由建筑物的供电系统提供，确保短路保护设备的额定电流不大于250V,20A。

警告

此產品的短路(過載電流)保護由建築物的供電系統提供，確保短路保護設備的額定電流不大於250V,20A。

Warnung

Dieses Produkt ist darauf angewiesen, dass im Gebäude ein Kurzschluss- bzw. Überstromschutz installiert ist. Stellen Sie sicher, dass der Nennwert der Schutzvorrichtung nicht mehr als: 250 V, 20 A beträgt.

¡Advertencia!

Este equipo utiliza el sistema de protección contra cortocircuitos (o sobrecorrientes) del edificio. Asegúrese de que el dispositivo de protección no sea superior a: 250 V, 20 A.

Attention

Pour ce qui est de la protection contre les courts-circuits (surtension), ce produit dépend de l'installation électrique du local. Vérifiez que le courant nominal du dispositif de protection n'est pas supérieur à :250 V, 20 A.

מוצר זה מסתמך על הגנה המותקנת במבנים למניעת קצר חשמלי. יש לוודא כי המכשיר המגן מפני הקצר החשמלי הוא לא יותר מ-250 V, 20 A.

هذا المنتج يعتمد على معدات الحماية من الدوائر القصيرة التي تم تثبيتها في
المبنى
تأكد من أن تقييم الجهاز الوقائي ليس أكثر من: 20A, 250V

경고!

이 제품은 전원의 단락(과전류)방지에 대해서 전적으로 건물의 관련 설비에 의존합니다. 보호장치의 정격이 반드시 250V(볼트), 20A(암페어)를 초과하지 않도록 해야 합니다.

Waarschuwing

Dit product is afhankelijk van de kortsluitbeveiliging (overspanning) van uw elektrische installatie. Controleer of het beveiligde apparaat niet groter gedimensioneerd is dan 220V, 20A.

Power Disconnection Warning



Warning!

The system must be disconnected from all sources of power and the power cord removed from the power supply module(s) before accessing the chassis interior to install or remove system components.

電源切斷の警告

システムコンポーネントの取り付けまたは取り外しのために、シャーシ内部にアクセスするには、

システムの電源はすべてのソースから切斷され、電源コードは電源モジュールから取り外す必要があります。

警告

在你打开机箱并安装或移除内部器件前，必须将系统完全断电，并移除电源线。

警告

在您打開機殼安裝或移除內部元件前，必須將系統完全斷電，並移除電源線。

Warnung

Das System muss von allen Quellen der Energie und vom Netzanschlusskabel getrennt sein, das von den Spg.Versorgungsteilmodulen entfernt wird, bevor es auf den Chassisinnenraum zurückgreift, um Systemsbestandteile anzubringen oder zu entfernen.

¡Advertencia!

El sistema debe ser disconnected de todas las fuentes de energía y del cable eléctrico quitado de los módulos de fuente de alimentación antes de tener acceso el interior del chasis para instalar o para quitar componentes de sistema.

Attention

Le système doit être débranché de toutes les sources de puissance ainsi que de son cordon d'alimentation secteur avant d'accéder à l'intérieur du chasis pour installer ou enlever des composants de système.

אזהרה מפני ניתוק חשמלי

אזהרה!

יש לנתק את המערכת מכל מקורות החשמל ויש להסיר את כבל החשמלי מהספק לפני גישה לחלק הפנימי של המארז לצורך התקנת או הסרת רכיבים.

يجب فصل النظام من جميع مصادر الطاقة وإزالة سلك الكهرباء من وحدة امداد الطاقة قبل الوصول إلى المناطق الداخلية للهيكल لتثبيت أو إزالة مكونات الجهاز

경고!

시스템에 부품들을 장착하거나 제거하기 위해서는 새시 내부에 접근하기 전에 반드시 전원 공급장치로부터 연결되어있는 모든 전원과 전기코드를 분리해 주어야 합니다.

Waarschuwing

Voordat u toegang neemt tot het binnenwerk van de behuizing voor het installeren of verwijderen van systeem onderdelen, dient u alle spanningsbronnen en alle stroomkabels aangesloten op de voeding(en) van de behuizing te verwijderen

Equipment Installation



Warning!

Only trained and qualified personnel should be allowed to install, replace, or service this equipment.

機器の設置

トレーニングを受け認定された人だけがこの装置の設置、交換、またはサービスを許可されています。

警告

只有经过培训且具有资格的人员才能进行此设备的安装、更换和维修。

警告

只有經過受訓且具資格人員才可安裝、更換與維修此設備。

Warnung

Das Installieren, Ersetzen oder Bedienen dieser Ausrüstung sollte nur geschultem, qualifiziertem Personal gestattet werden.

¡Advertencia!

Solamente el personal calificado debe instalar, reemplazar o utilizar este equipo.

Attention

Il est vivement recommandé de confier l'installation, le remplacement et la maintenance de ces équipements à des personnels qualifiés et expérimentés.

אזהרה!

צוות מוסמך בלבד רשאי להתקין, להחליף את הציוד או לתת שירות עבור הציוד.

يجب أن يسمح فقط للموظفين المؤهلين والمدربين لتثبيت واستبدال أو خدمة هذا الجهاز

경고!

훈련을 받고 공인된 기술자만이 이 장비의 설치, 교체 또는 서비스를 수행할 수 있습니다.

Waarschuwing

Deze apparatuur mag alleen worden geïnstalleerd, vervangen of hersteld door geschoold en gekwalificeerd personeel.

Restricted Area



Warning!

This unit is intended for installation in restricted access areas. A restricted access area can be accessed only through the use of a special tool, lock and key, or other means of security. (This warning does not apply to workstations).

アクセス制限区域

このユニットは、アクセス制限区域に設置されることを想定しています。

アクセス制限区域は、特別なツール、鍵と錠前、その他のセキュリティの手段を用いてのみ出入りが可能です。

警告

此部件应安装在限制进出的场所，限制进出的场所指只能通过使用特殊工具、锁和钥匙或其它安全手段进出的场所。

警告

此裝置僅限安裝於進出管制區域，進出管制區域係指僅能以特殊工具、鎖頭及鑰匙或其他安全方式才能進入的區域。

Warnung

Diese Einheit ist zur Installation in Bereichen mit beschränktem Zutritt vorgesehen. Der Zutritt zu derartigen Bereichen ist nur mit einem Spezialwerkzeug, Schloss und Schlüssel oder einer sonstigen Sicherheitsvorkehrung möglich.

¡Advertencia!

Esta unidad ha sido diseñada para instalación en áreas de acceso restringido. Sólo puede obtenerse acceso a una de estas áreas mediante la utilización de una herramienta especial, cerradura con llave u otro medio de seguridad.

Attention

Cet appareil doit être installée dans des zones d'accès réservés. L'accès à une zone d'accès réservé n'est possible qu'en utilisant un outil spécial, un mécanisme de verrouillage et une clé, ou tout autre moyen de sécurité.

אזור עם גישה מוגבלת**אזהרה!**

יש להתקין את היחידה באזורים שיש בהם הגבלת גישה. הגישה ניתנת בעזרת כלי אבטחה בלבד (מפתח, מנעול וכד').

تم تخصيص هذه الوحدة لتركيبها في مناطق محظورة .
يمكن الوصول إلى منطقة محظورة فقط من خلال استخدام أداة خاصة،
قفل ومفتاح أو أي وسيلة أخرى للأمان

경고!

이 장치는 접근이 제한된 구역에 설치하도록 되어 있습니다. 특수도구, 잠금 장치 및 키, 또는 기타 보안 수단을 통해서만 접근 제한 구역에 들어갈 수 있습니다.

Waarschuwing

Dit apparaat is bedoeld voor installatie in gebieden met een beperkte toegang. Toegang tot dergelijke gebieden kunnen alleen verkregen worden door gebruik te maken van speciaal gereedschap, slot en sleutel of andere veiligheidsmaatregelen.

Battery Handling**Warning!**

There is the danger of explosion if the battery is replaced incorrectly. Replace the battery only with the same or equivalent type recommended by the manufacturer. Dispose of used batteries according to the manufacturer's instructions

電池の取り扱い

電池交換が正しく行われなかった場合、破裂の危険性があります。交換する電池はメーカーが推奨する型、または同等のものを使用下さい。使用済電池は製造元の指示に従って処分して下さい。

警告

電池更換不當會有爆炸危險。請只使用同類電池或製造商推薦的功能相當的電池更換原有電池。請按製造商的說明處理廢舊電池。

警告

電池更換不當會有爆炸危險。請使用製造商建議之相同或功能相當的電池更換原有電池。請按照製造商的說明指示處理廢棄舊電池。

Warnung

Bei Einsetzen einer falschen Batterie besteht Explosionsgefahr. Ersetzen Sie die Batterie nur durch den gleichen oder vom Hersteller empfohlenen Batterietyp. Entsorgen Sie die benutzten Batterien nach den Anweisungen des Herstellers.

Attention

Danger d'explosion si la pile n'est pas remplacée correctement. Ne la remplacer que par une pile de type semblable ou équivalent, recommandée par le fabricant. Jeter les piles usagées conformément aux instructions du fabricant.

¡Advertencia!

Existe peligro de explosión si la batería se reemplaza de manera incorrecta. Reemplazar la batería exclusivamente con el mismo tipo o el equivalente recomendado por el fabricante. Desechar las baterías gastadas según las instrucciones del fabricante.

אזהרה!

קיימת סכנת פיצוץ של הסוללה במידה והוחלפה בדרך לא תקינה. יש להחליף את הסוללה בסוג התואם מחברת יצרן מומלצת.

סילוק הסוללות המשומשות יש לבצע לפי הוראות היצרן.

هناك خطر من انفجار في حالة استبدال البطارية بطريقة غير صحيحة فعليك استبدال البطارية فقط بنفس النوع أو ما يعادلها كما أوصت به الشركة المصنعة تخلص من البطاريات المستعملة وفقا لتعليمات الشركة الصانعة

경고!

배터리가 올바르게 교체되지 않으면 폭발의 위험이 있습니다. 기존 배터리와 동일하거나 제조사에서 권장하는 동등한 종류의 배터리로만 교체해야 합니다. 제조사의 안내에 따라 사용된 배터리를 처리하여 주십시오.

Waarschuwing

Er is ontploffingsgevaar indien de batterij verkeerd vervangen wordt. Vervang de batterij slechts met hetzelfde of een equivalent type die door de fabrikant aanbevolen wordt. Gebruikte batterijen dienen overeenkomstig fabrieksvoorschriften afgevoerd te worden.

Redundant Power Supplies



Warning!

This unit might have more than one power supply connection. All connections must be removed to de-energize the unit.

冗長電源装置

このユニットは複数の電源装置が接続されている場合があります。
ユニットの電源を切るためには、すべての接続を取り外さなければなりません。

警告

此部件连接的电源可能不止一个，必须将所有电源断开才能停止给该部件供电。

警告

此裝置連接的電源可能不只一個，必須切斷所有電源才能停止對該裝置的供電。

Warnung

Dieses Gerät kann mehr als eine Stromzufuhr haben. Um sicherzustellen, dass der Einheit kein Strom zugeführt wird, müssen alle Verbindungen entfernt werden.

¡Advertencia!

Puede que esta unidad tenga más de una conexión para fuentes de alimentación. Para cortar por completo el suministro de energía, deben desconectarse todas las conexiones.

Attention

Cette unité peut avoir plus d'une connexion d'alimentation. Pour supprimer toute tension et tout courant électrique de l'unité, toutes les connexions d'alimentation doivent être débranchées.

אם קיים יותר מספק אחד

אזהרה!

ליחידה יש יותר מחיבור אחד של ספק. יש להסיר את כל החיבורים על מנת לרוקן את היחידה.

قد يكون لهذا الجهاز عدة اتصالات بوحدات امداد الطاقة.
يجب إزالة كافة الاتصالات لعزل الوحدة عن الكهرباء

경고!

이 장치에는 한 개 이상의 전원 공급 단자가 연결되어 있을 수 있습니다. 이 장치에 전원을 차단하기 위해서는 모든 연결 단자를 제거해야만 합니다.

Waarschuwing

Deze eenheid kan meer dan één stroomtoevoeraansluiting bevatten. Alle aansluitingen dienen verwijderd te worden om het apparaat stroomloos te maken.

Backplane Voltage



Warning!

Hazardous voltage or energy is present on the backplane when the system is operating. Use caution when servicing.

バックプレーンの電圧

システムの稼働中は危険な電圧または電力が、バックプレーン上にかかっています。
修理するにはご注意ください。

警告

当系统正在进行时，背板上有很危险的电压或能量，进行维修时务必小心。

警告

當系統正在進行時，背板上有危險的電壓或能量，進行維修時務必小心。

Warnung

Wenn das System in Betrieb ist, treten auf der Rückwandplatine gefährliche Spannungen oder Energien auf. Vorsicht bei der Wartung.

¡Advertencia!

Quando el sistema está en funcionamiento, el voltaje del plano trasero es peligroso. Tenga cuidado cuando lo revise.

Attention

Lorsque le système est en fonctionnement, des tensions électriques circulent sur le fond de panier. Prendre des précautions lors de la maintenance.

מתח בפנל האחורי

אזהרה!

קיימת סכנת מתח בפנל האחורי בזמן תפעול המערכת. יש להיזהר במהלך העבודה.

هناك خطر من التيار الكهربائي أو الطاقة الموجودة على اللوحة عندما يكون النظام يعمل كن حذرا عند خدمة هذا الجهاز

경고!

시스템이 동작 중일 때 후면판 (Backplane)에는 위험한 전압이나 에너지가 발생 합니다. 서비스 작업 시 주의하십시오.

Waarschuwing

Een gevaarlijke spanning of energie is aanwezig op de backplane wanneer het systeem in gebruik is. Voorzichtigheid is geboden tijdens het onderhoud.

Comply with Local and National Electrical Codes**Warning!**

Installation of the equipment must comply with local and national electrical codes.

地方および国の電気規格に準拠

機器の取り付けはその地方および国の電気規格に準拠する必要があります。

警告

设备安装必须符合本地与本国电气法规。

警告

設備安裝必須符合本地與本國電氣法規。

Warnung

Die Installation der Geräte muss den Sicherheitsstandards entsprechen.

¡Advertencia!

La instalación del equipo debe cumplir con las normas de electricidad locales y nacionales. Attention

L'équipement doit être installé conformément aux normes électriques nationales et locales.

תאום חוקי החשמל הארצי

אזהרה!

התקנת הציוד חייבת להיות תואמת לחוקי החשמל המקומיים והארציים.

تركيب المعدات الكهربائية يجب أن يمتثل للقوانين المحلية والوطنية المتعلقة بالكهرباء

경고!

현 지역 및 국가의 전기 규정에 따라 장비를 설치해야 합니다.

Waarschuwing

Bij installatie van de apparatuur moet worden voldaan aan de lokale en nationale elektriciteitsvoorschriften.

Product Disposal**Warning!**

Ultimate disposal of this product should be handled according to all national laws and regulations.

製品の廃棄

この製品を廃棄処分する場合、国の関係する全ての法律・条例に従い処理する必要があります。

警告

本产品的废弃处理应根据所有国家的法律和规章进行。

警告

本產品的廢棄處理應根據所有國家的法律和規章進行。

Warnung

Die Entsorgung dieses Produkts sollte gemäß allen Bestimmungen und Gesetzen des Landes erfolgen.

¡Advertencia!

Al deshacerse por completo de este producto debe seguir todas las leyes y reglamentos nacionales.

Attention

La mise au rebut ou le recyclage de ce produit sont généralement soumis à des lois et/ou directives de respect de l'environnement. Renseignez-vous auprès de l'organisme compétent.

סילוק המוצר**אזהרה!**

סילוק סופי של מוצר זה חייב להיות בהתאם להנחיות וחוקי המדינה.

عند التخلص النهائي من هذا المنتج ينبغي التعامل معه وفقا لجميع القوانين واللوائح الوطنية

경고!

이 제품은 해당 국가의 관련 법규 및 규정에 따라 폐기되어야 합니다.

Waarschuwing

De uiteindelijke verwijdering van dit product dient te geschieden in overeenstemming met alle nationale wetten en reglementen.

Hot Swap Fan Warning**Warning!**

The fans might still be turning when you remove the fan assembly from the chassis. Keep fingers, screwdrivers, and other objects away from the openings in the fan assembly's housing.

ファン・ホットスワップの警告

シャーシから冷却ファン装置を取り外した際、ファンがまだ回転している可能性があります。ファンの開口部に、指、ドライバー、およびその他のものを近づけないで下さい。

警告

当您从机架移除风扇装置，风扇可能仍在转动。小心不要将手指、螺丝起子和其他物品太靠近风扇

警告

當您從機架移除風扇裝置，風扇可能仍在轉動。小心不要將手指、螺絲起子和其他物品太靠近風扇。

Warnung

Die Lüfter drehen sich u. U. noch, wenn die Lüfterbaugruppe aus dem Chassis genommen wird. Halten Sie Finger, Schraubendreher und andere Gegenstände von den Öffnungen des Lüftergehäuses entfernt.

¡Advertencia!

Los ventiladores podran dar vuelta cuando usted quite el montaje del ventilador del chasis. Mantenga los dedos, los destornilladores y todos los objetos lejos de las aberturas del ventilador

Attention

Il est possible que les ventilateurs soient toujours en rotation lorsque vous retirerez le bloc ventilateur du châssis. Prenez garde à ce que doigts, tournevis et autres objets soient éloignés du logement du bloc ventilateur.

אזהרה!

כאשר מסירים את חלקי המאוורר מהמארז, יתכן והמאווררים עדיין עובדים. יש להרחיק למרחק בטוח את האצבעות וכלי עבודה שונים מהפתחים בתוך המאוורר

من الممكن أن المراوح لا تزال تدور عند إزالة كتلة المروحة من الهيكل يجب إبقاء الأصابع ومفكات البراغي وغيرها من الأشياء بعيدا عن الفتحات في كتلة المروحة.

경고!

새시로부터 팬 조립품을 제거할 때 팬은 여전히 회전하고 있을 수 있습니다. 팬 조립품 외관의 열려있는 부분들로부터 손가락 및 스크류드라이버, 다른 물체들이 가까이 하지 않도록 배치해 주십시오.

Waarschuwing

Het is mogelijk dat de ventilator nog draait tijdens het verwijderen van het ventilatorsamenstel uit het chassis. Houd uw vingers, schroevendraaiers en eventuele andere voorwerpen uit de buurt van de openingen in de ventilatorbehuizing.

Power Cable and AC Adapter



Warning!

When installing the product, use the provided or designated connection cables, power cables and AC adaptors. Using any other cables and adaptors could cause a malfunction or a fire. Electrical Appliance and Material Safety Law prohibits the use of UL or CSA -certified cables (that have UL/CSA shown on the code) for any other electrical devices than products designated by Supermicro only.

電源コードとACアダプター

製品を設置する場合、提供または指定された接続ケーブル、電源コードとACアダプターを使用下さい。他のケーブルやアダプタを使用すると故障や火災の原因になることがあります。電気用品安全法は、ULまたはCSA認定のケーブル(UL/CSEマークがコードに表記)を Supermicroが指定する製品以外に使用することを禁止しています。

警告

安装此产品时,请使用本身提供的或指定的连接线,电源线和电源适配器.使用其它线材或适配器可能会引起故障或火灾。除了Supermicro所指定的产品,电气用品和材料安全法律规定禁止使用未经UL或CSA认证的线材。(线材上会显示UL/CSA符号)。

警告

安裝此產品時,請使用本身提供的或指定的連接線,電源線和電源適配器.使用其它線材或適配器可能會引起故障或火災。除了Supermicro所指定的產品,電氣用品和材料安全法律規定禁止使用未經UL或CSA認證的線材。(線材上會顯示UL/CSA符號)。

Warnung

Bei der Installation des Produkts, die zur Verfügung gestellten oder benannt Anschlusskabel, Stromkabel und Netzteile. Verwendung anderer Kabel und Adapter kann zu einer Fehlfunktion oder ein Brand entstehen. Elektrische Geräte und Material Safety Law verbietet die Verwendung von UL-oder CSA-zertifizierte Kabel, UL oder CSA auf der Code für alle anderen elektrischen Geräte als Produkte von Supermicro nur bezeichnet gezeigt haben.

¡Advertencia!

Al instalar el producto, utilice los cables de conexión previstos o designados, los cables y adaptadores de CA. La utilización de otros cables y adaptadores podría ocasionar un mal funcionamiento o un incendio. Aparatos Eléctricos y la Ley de Seguridad del Material prohíbe el uso de UL o CSA cables certificados que tienen UL o CSA se muestra en el código de otros dispositivos eléctricos que los productos designados por Supermicro solamente.

Attention

Lors de l'installation du produit, utilisez les bables de connection fournis ou désigné. L'utilisation d'autres cables et adaptateurs peut provoquer un dysfonctionnement ou un incendie. Appareils électroménagers et de loi sur la sécurité Matériel interdit l'utilisation de UL ou CSA câbles certifiés qui ont UL ou CSA indiqué sur le code pour tous les autres appareils électriques que les produits désignés par Supermicro seulement.

חשמליים ומתאמי AC

אזהרה!

כאשר מתקינים את המוצר, יש להשתמש בכבלים, ספקים ומתאמים AC אשר נועדו וסופקו לשם כך. שימוש בכל כבל או מתאם אחר יכול לגרום לתקלה או קצר חשמלי. על פי חוקי שימוש במכשירי חשמל וחוקי בטיחות, קיים איסור להשתמש בכבלים המוסמכים ב- UL או ב- CSA (כשאר מופיע עליהם קוד של UL/CSA) עבור כל מוצר חשמלי אחר שלא צויין על ידי סופרמיקרו בלבד.

عند تركيب الجهاز يجب استخدام كابلات التوصيل، والكابلات الكهربائية ومحولات التيار المتردد

التي . أن استخدام أي كابلات ومحولات أخرى يتسبب في حدوث عطل أو حريق. تم توفيرها لك مع المنتج

الأجهزة الكهربائية ومواد قانون السلامة يحظر استخدام الكابلات UL أو CSA معتمدة من قبل

لأي أجهزة كهربائية أخرى غير المنتجات المعينة من قبل Supermicro (التي تحمل علامة UL/CSA)

경고!

제품을 설치할 때에는 제공되거나 지정된 연결케이블과 전원케이블, AC어댑터를 사용해야 합니다. 그 밖의 다른 케이블들이나 어댑터들은 고장 또는 화재의 원인이 될 수 있습니다. 전기용품안전법 (Electrical Appliance and Material Safety Law)은 슈퍼마이크로에서 지정한 제품들 외에는 그 밖의 다른 전기 장치들을 위한 UL 또는 CSA에서 인증한 케이블(전선 위에 UL/CSA가 표시)들의 사용을 금지합니다.

Waarschuwing

Bij het installeren van het product, gebruik de meegeleverde of aangewezen kabels, stroomkabels en adapters. Het gebruik van andere kabels en adapters kan leiden tot een storing of een brand. Elektrisch apparaat en veiligheidsinformatiebladen wet verbiedt het gebruik van UL of CSA gecertificeerde kabels die UL of CSA die op de code voor andere elektrische apparaten dan de producten die door Supermicro alleen.

Chapter 5

Advanced Serverboard Setup

This chapter covers the steps required to install the X9DRI-LN4F+ serverboard into the chassis, connect the data and power cables and install add-on cards. All serverboard jumpers and connections are also described. A layout and quick reference chart are included in this chapter for your reference. Remember to completely close the chassis when you have finished working with the serverboard to better cool and protect the system.

5-1 Handling the Serverboard

Electrostatic Discharge (ESD) can damage electronic components. To prevent damage to any printed circuit boards (PCBs), it is important to handle them very carefully (see previous chapter). To prevent the serverboard from bending, keep one hand under the center of the board to support it when handling. The following measures are generally sufficient to protect your equipment from electric static discharge.

Precautions

- Use a grounded wrist strap designed to prevent Electrostatic Discharge (ESD).
- Touch a grounded metal object before removing any board from its antistatic bag.
- Handle a board by its edges only; do not touch its components, peripheral chips, memory modules or gold contacts.
- When handling chips or modules, avoid touching their pins.
- Put the serverboard, add-on cards and peripherals back into their antistatic bags when not in use.
- For grounding purposes, make sure your computer chassis provides excellent conductivity between the power supply, the case, the mounting fasteners and the serverboard.

Unpacking

The serverboard is shipped in antistatic packaging to avoid electrical static discharge. When unpacking the board, make sure the person handling it is static protected.

5-2 Connecting Cables

Several cables need to be connected to the serverboard. These include the data cables for the peripherals and control panel and the power cables.

Connecting Data Cables

The cables used to transfer data from the peripheral devices have been carefully routed to prevent them from blocking the flow of cooling air that moves through the system from front to back. If you need to disconnect any of these cables, you should take care to keep them routed as they were originally after reconnecting them (make sure the red wires connect to the pin 1 locations). The following data cables (with their locations noted) should be connected. (See the layout on page 5-10 for connector locations.)

- SATA drive data cables (I-SATA0 ~ I-SATA5)
- Control Panel cable (JF1)
- USB cable for front side access (USB4/5)

Important! Make sure the the cables do not come into contact with the fans.

Connecting Power Cables

The X9DRI-LN4F+ has a 24-pin primary power supply connector (JPW1) for connection to the ATX power supply. In addition, there are two 8-pin 12V processor power connectors (JPW2 and JPW3) that must be connected to your power supply. See Section 5-9 for power connector pin definitions.

Connecting the Control Panel

JF1 contains header pins for various front control panel connectors. See Figure 5-1 for the pin locations of the various front control panel buttons and LED indicators.

All JF1 wires have been bundled into a single cable to simplify this connection. Make sure the red wire plugs into pin 1 as marked on the board. The other end connects to the Control Panel PCB board, located just behind the system status LEDs on the chassis. See Chapter 5 for details and pin descriptions.

Figure 5-1. Control Panel Header Pins

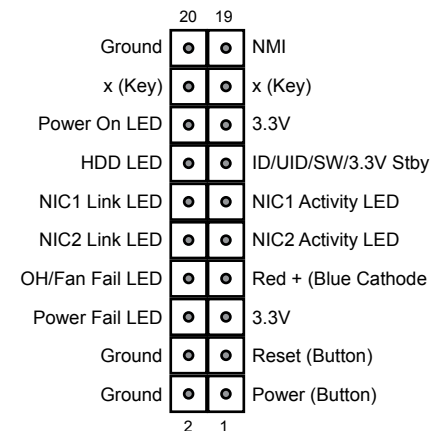

5-3 Rear I/O Ports

See Figure 5-2 below for the colors and locations of the various I/O ports.

Figure 5-2. Rear I/O Ports

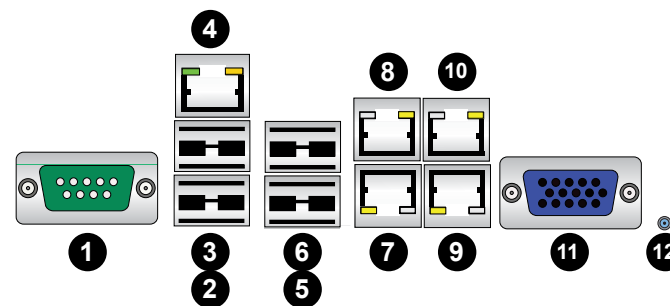

| Rear I/O Ports | | | |
|----------------|--------------------|----|------------|
| 1 | COM Port 1 | 7 | LAN Port 1 |
| 2 | USB Port 0 | 8 | LAN Port 2 |
| 3 | USB Port 1 | 9 | LAN Port 3 |
| 4 | Dedicated IPMI LAN | 10 | LAN Port 4 |
| 5 | USB Port 2 | 11 | VGA Port |
| 6 | USB Port 3 | 12 | UID Switch |

5-4 Installing the Processor and Heatsink

Caution: When handling the processor package, avoid placing direct pressure on the label area of the fan.

Notes:

- Always connect the power cord last and always remove it before adding, removing or changing any hardware components. Make sure that you install the processor into the CPU socket before you install the CPU heatsink.
- If you buy a CPU separately, make sure that you use an Intel-certified multi-directional heatsink only.
- Make sure to install the serverboard into the chassis before you install the CPU heatsinks.
- When receiving a serverboard without a processor pre-installed, make sure that the plastic CPU socket cap is in place and none of the socket pins are bent; otherwise, contact your retailer immediately.
- Refer to the Supermicro web site for updates on CPU support.

Installing an LGA2011 Processor

1. There are two levers on the LGA2011 socket. First press and release the load lever labeled 'Open 1st'.
2. Press the second load lever labeled 'Close 1st' to release the load plate from its locked position.

Press down on the lever labeled 'Close 1st'

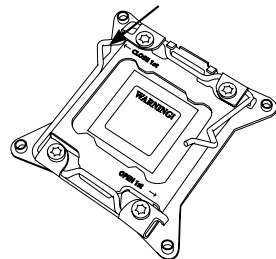

Pull lever away from the socket

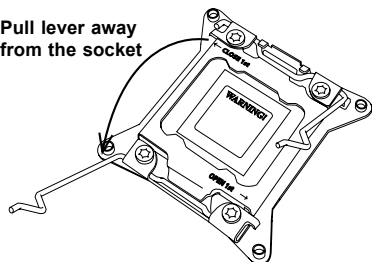

3. With the lever labeled 'Close 1st' fully retracted, gently push down on the 'Open 1st' lever to open the load plate. Lift the load plate to open it completely.
4. Using your thumb and the index finger, remove the 'WARNING' plastic cap from the socket.
5. Use your thumb and index finger to hold the CPU by its edges. Align the CPU keys, which are semi-circle cutouts, against the socket keys.
6. Once they are aligned, carefully lower the CPU straight down into the socket. (Do not drop the CPU on the socket. Do not move the CPU horizontally or vertically and do not rub the CPU against any pins of the socket, which may damage the CPU or the socket.)

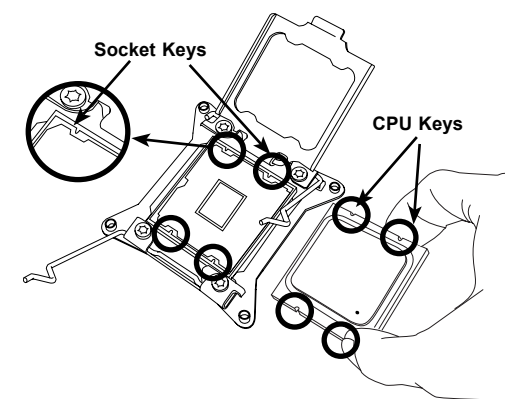
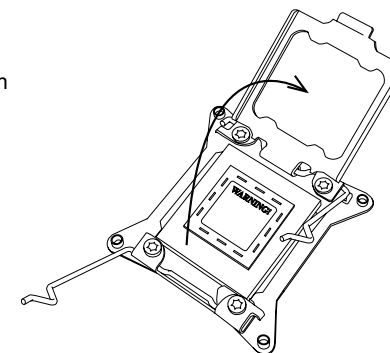
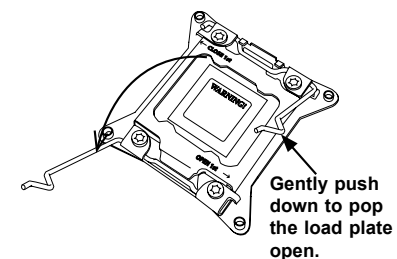

Caution: You can only install the CPU to the socket in one direction. Make sure that the CPU is properly inserted into the socket before closing the load plate. If it doesn't close properly, do not force it as it may damage your CPU. Instead, open the load plate again and double-check that the CPU is aligned properly.

7. With the CPU in the socket, inspect the four corners of the CPU to make sure that they are flush with the socket.
8. Close the load plate. Lock the lever labeled 'Close 1st', then lock the lever labeled 'Open 1st'. Use your thumb to gently push the load levers down until the lever locks.

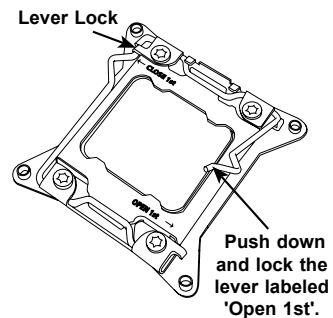
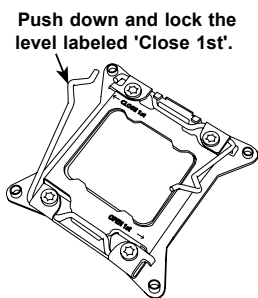
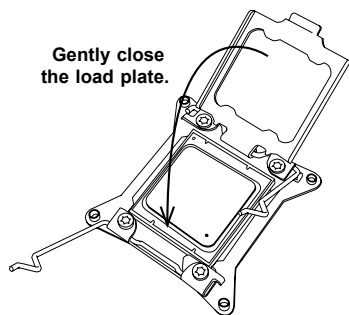

Installing a Passive CPU Heatsink

1. Do not apply any thermal grease to the heatsink or the CPU die -- the required amount has already been applied.
2. Place the heatsink on top of the CPU so that the four mounting holes are aligned with those on the Serverboard's and the Heatsink Bracket underneath.
3. Screw in two diagonal screws (i.e., the #1 and the #2 screws) until just snug (-do not over-tighten the screws to avoid possible damage to the CPU.)
4. Finish the installation by fully tightening all four screws.

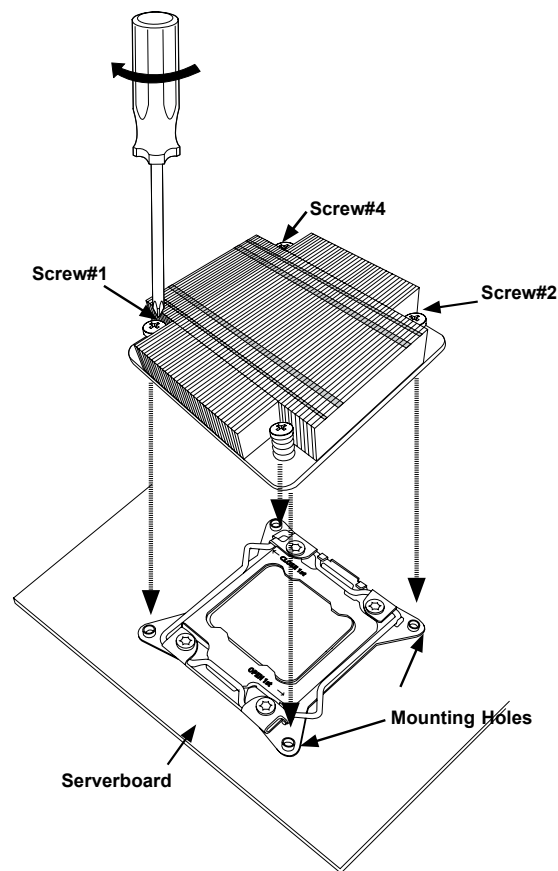

Removing the Heatsink

Caution: We do not recommend that the CPU or the heatsink be removed. However, if you do need to uninstall the heatsink, please follow the instructions below to uninstall the heatsink to prevent damage done to the CPU or the CPU socket.

1. Unscrew the heatsink screws from the serverboard in the sequence as shown in the illustration below.
2. Gently wriggle the heatsink to loosen it from the CPU. (Do not use excessive force when wriggling the heatsink!)
3. Once the heatsink is loosened, remove it from the CPU.
4. Remove the used thermal grease and clean the surface of the CPU and the heatsink. Reapply the proper amount of thermal grease on the surface before reinstalling the heatsink. (Do not reuse old thermal grease!)

Loosen screws in sequence as shown.

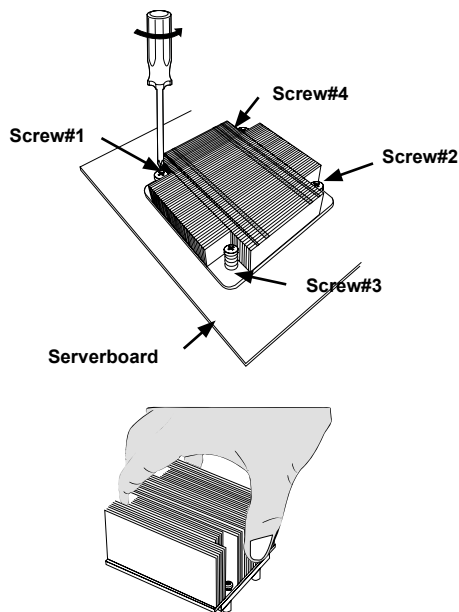

5-5 Installing Memory

Caution: Exercise extreme care when installing or removing DIMM modules to prevent any possible damage.

Memory Support

The X9DRi-LN4F+ supports up to 1.5 TB of LRDIMM (Load Reduced DIMM), 768 GB of RDIMM (Registered DIMMs) or 128 GB of UDIMM (Unbuffered DIMMs) ECC/Non-ECC DDR3-1866/1600/1333/1066/800 SDRAM. For best performance, install pairs of memory modules of the same type and speed. Please refer to our website for any updates to supported memory. All channels will run at the fastest common frequency.

DIMM Installation

Installing Memory Modules

1. Insert the desired number of DIMMs into the memory slots starting with P1-DIMMA1. See the Memory Installation Tables on the following pages.
2. Insert each DIMM module vertically into its slot. Pay attention to the notch along the bottom of the module to avoid installing incorrectly (see Figure 5-3).
3. Use your thumbs to gently press down on both ends of the DIMM module until it snaps into place in the slot. Repeat for all modules.
4. Press the release tabs to the locked positions to secure the DIMM module into the slot.

Figure 5-3. DIMM Installation

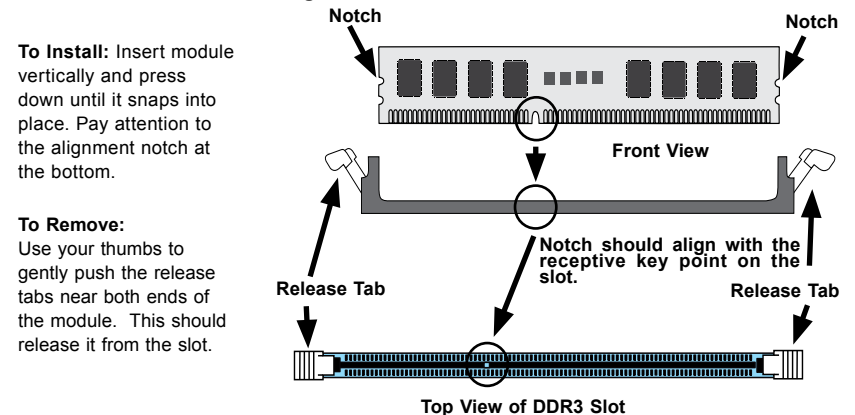

| Processor and Memory Module Population | |
|--|---|
| Number of CPUs+DIMMs | CPU and Memory Population Configuration Table |
| 1 CPU & 2 DIMMs | CPU1 P1-DIMMA1/P1-DIMMB1 |
| 1 CPU & 4 DIMMs | CPU1 P1-DIMMA1/P1-DIMMB1, P1-DIMMC1/P1-DIMMD1 |
| 1 CPU & 5-8 DIMMs | CPU1 P1-DIMMA1/P1-DIMMB1, P1-DIMMC1/P1-DIMMD1, P1-DIMMA2/P1-DIMMB2, P1-DIMMC2/P1-DIMMD2 |
| 1 CPU & 9-12 DIMMs | CPU1 P1-DIMMA1/P1-DIMMB1, P1-DIMMC1/P1-DIMMD1, P1-DIMMA2/P1-DIMMB2, P1-DIMMC2/P1-DIMMD2, P1-DIMMA3/P1-DIMMB3, P1-DIMMC3/P1-DIMMD3 |
| 2 CPUs & 4 DIMMs | CPU1 + CPU2 P1-DIMMA1/P1-DIMMB1, P2-DIMME1/P2-DIMMF1 |
| 2 CPUs & 6 DIMMs | CPU1 + CPU2 P1-DIMMA1/P1-DIMMB1, P2-DIMME1/P2-DIMMF1, P1-DIMMC1/P1-DIMMD1 |
| 2 CPUs & 8 DIMMs | CPU1 + CPU2 P1-DIMMA1/P1-DIMMB1, P2-DIMME1/P2-DIMMF1, P1-DIMMC1/P1-DIMMD1, P2-DIMMG1/P2-DIMMH1 |
| 2 CPUs & 9-12 DIMMs | CPU1/CPU2 P1-DIMMA1/P1-DIMMB1, P2-DIMME1/P2-DIMMF1, P1-DIMMC1/P1-DIMMD1, P2-DIMMG1/P2-DIMMH1, P1-DIMMA2/P1-DIMMB2, P2-DIMME2/P2-DIMMF2 |
| 2 CPUs & 13 DIMMs-24 DIMMs | CPU1/CPU2 P1-DIMMA1/P1-DIMMB1, P2-DIMME1/P2-DIMMF1, P1-DIMMC1/P1-DIMMD1, P2-DIMMG1/P2-DIMMH1, P1-DIMMA2/P1-DIMMB2, P2-DIMME2/P2-DIMMF2, P1-DIMMC2/P1-DIMMD2, P2-DIMMG2/P2-DIMMH2, P1-DIMMA3/P1-DIMMB3, P2-DIMME3/P2-DIMMF3, P1-DIMMC3/P1-DIMMD3, P2-DIMMG3/P2-DIMMH3 |

Note: 1866 MHz memory support is dependent on Intel E5-2600v2 CPUs. For Intel E5-2600(v2) processor support, BIOS version 3.0 or above is required.

Populating UDIMM (ECC/Non-ECC) Memory Modules

| Intel E5-2600(v2) Series Processor UDIMM Memory Support | | | | | | | | | | | |
|---|--|-----|-----|---|------------------------|------------|------------------|---------------------|------------------------|------------|------------------|
| Ranks Per DIMM & Data Width | Memory Capacity Per DIMM (See the Note below) | | | Speed (MT/s) and Voltage Validated by Slot per Channel (SPC) and DIMM Per Channel (DPC) | | | | | | | |
| | | | | 2 Slots Per Channel | | | | 3 Slots Per Channel | | | |
| | | | | 1DPC | | 2DPC | | 1DPC | | 2DPC | |
| | | | | 1.35V | 1.5V | 1.35V | 1.5V | 1.35V | 1.5V | 1.35V | 1.5V |
| SRx8 Non-ECC | 1GB | 2GB | 4GB | NA | 1066, 1333, 1600, 1866 | NA | 1066, 1333, 1600 | N/A | 1066, 1333, 1600, 1866 | N/A | 1066, 1333, 1600 |
| DRx8 Non-ECC | 2GB | 4GB | 8GB | NA | 1066, 1333, 1600, 1866 | NA | 1066, 1333, 1600 | N/A | 1066, 1333, 1600, 1866 | N/A | 1066, 1333, 1600 |
| SRx16 Non-ECC | 512MB | 1GB | 2GB | NA | 1066, 1333, 1600, 1866 | NA | 1066, 1333, 1600 | N/A | 1066, 1333, 1600, 1866 | N/A | 1066, 1333, 1600 |
| SRx8 ECC | 1GB | 2GB | 4GB | 1066, 1333 | 1066, 1600, 1866 | 1066, 1333 | 1066, 1600 | 1066, 1333 | 1066, 1333, 1600, 1866 | 1066, 1333 | 1066, 1333, 1600 |
| DRx8 ECC | 2GB | 4GB | 8GB | 1066, 1333 | 1066, 1600, 1866 | 1066, 1333 | 1066, 1600 | 1066, 1333 | 1066, 1333, 1600, 1866 | 1066, 1333 | 1066, 1333, 1600 |

Note: For detailed information on memory support and updates, please refer to the SMC Recommended Memory List posted on our website at <http://www.supermicro.com/support/resources/mem.cfm>.

Populating RDIMM (ECC) Memory Modules

| Intel E5-2600(v2) Series Processor RDIMM Memory Support | | | | | | | | | | | | | |
|---|--|------|------|---|------------------------|------------|------------|---------------------|------------------------|------------|------------------|-------|-----------|
| Ranks Per DIMM & Data Width | Memory Capacity Per DIMM (See the Note Below) | | | Speed (MT/s) and Voltage Validated by Slot per Channel (SPC) and DIMM Per Channel (DPC) | | | | | | | | | |
| | | | | 2 Slots Per Channel | | | | 3 Slots Per Channel | | | | | |
| | | | | 1DPC | | 2DPC | | 1 DPC | | 2DPC | | 3DPC | |
| | | | | 1.35V | 1.5V | 1.35V | 1.5V | 1.35V | 1.5V | 1.35V | 1.5V | 1.35V | 1.5V |
| SRx8 | 1GB | 2GB | 4GB | 1066, 1333 | 1066, 1333, 1600, 1866 | 1066, 1333 | 1066, 1600 | 1066, 1333 | 1066, 1333, 1600, 1866 | 1066, 1333 | 1066, 1333, 1600 | 800 | 800, 1066 |
| DRx8 | 2GB | 4GB | 8GB | 1066, 1333 | 1066, 1333, 1600, 1866 | 1066, 1333 | 1066, 1600 | 1066, 1333 | 1066, 1333, 1600, 1866 | 1066, 1333 | 1066, 1333, 1600 | 800 | 800, 1066 |
| SRx4 | 2GB | 4GB | 8GB | 1066, 1333 | 1066, 1333, 1600, 1866 | 1066, 1333 | 1066, 1600 | 1066, 1333 | 1066, 1333, 1600, 1866 | 1066, 1333 | 1066, 1333, 1600 | 800 | 800, 1066 |
| DRx4 | 4GB | 8GB | 16GB | 1066, 1333 | 1066, 1333, 1600, 1866 | 1066, 1333 | 1066, 1600 | 1066, 1333 | 1066, 1333, 1600, 1866 | 1066, 1333 | 1066, 1333, 1600 | 800 | 800, 1066 |
| QRx4 | 8GB | 16GB | 32GB | 800 | 800, 1066 | 800 | 800 | 800 | 800, 1066 | 800 | 800 | N/A | N/A |
| QRx8 | 4GB | 8GB | 16GB | 800 | 800, 1066 | 800 | 800 | 800 | 800, 1066 | 800 | 800 | N/A | N/A |

Note: For detailed information on memory support and updates, please refer to the SMC Recommended Memory List posted on our website at <http://www.supermicro.com/support/resources/mem.cfm>.

Populating UDIMM (ECC/Non-ECC) Memory Modules

| Intel E5-2600 Series Processor UDIMM Memory Support | | | | | | | | | | | |
|---|--|------|-------|---|------------|------|------------|---------------------|------------------|------------|------------|
| Ranks Per DIMM & Data Width | Memory Capacity Per DIMM (See the Note below) | | | Speed (MT/s) and Voltage Validated by Slot per Channel (SPC) and DIMM Per Channel (DPC) | | | | | | | |
| | | | | 2 Slots Per Channel | | | | 3 Slots Per Channel | | | |
| | 1DPC | | 2DPC | | 1DPC | | 2DPC | | | | |
| | 1.35V | 1.5V | 1.35V | 1.5V | 1.35V | 1.5V | 1.35V | 1.5V | 1.35V | 1.5V | |
| SRx8 Non-ECC | 1GB | 2GB | 4GB | NA | 1066, 1333 | NA | 1066, 1333 | N/A | 1066, 1333 | N/A | 1066, 1333 |
| DRx8 Non-ECC | 2GB | 4GB | 8GB | NA | 1066, 1333 | NA | 1066, 1333 | N/A | 1066, 1333 | N/A | 1066, 1333 |
| SRx16 Non-ECC | 512MB | 1GB | 2GB | NA | 1066, 1333 | NA | 1066, 1333 | N/A | 1066, 1333 | N/A | 1066, 1333 |
| SRx8 ECC | 1GB | 2GB | 4GB | 1066, 1333 | 1066, 1333 | 1066 | 1066, 1333 | 1066 | 1066, 1333, 1333 | 1066, 1333 | 1066, 1333 |
| DRx8 ECC | 2GB | 4GB | 8GB | 1066, 1333 | 1066, 1333 | 1066 | 1066, 1333 | 1066 | 1066, 1333, 1333 | 1066, 1333 | 1066, 1333 |

Note: For detailed information on memory support and updates, please refer to the SMC Recommended Memory List posted on our website at <http://www.supermicro.com/support/resources/mem.cfm>.

Populating RDIMM (ECC) Memory Modules

| Intel E5-2600 Series Processor RDIMM Memory Support | | | | | | | | | | | | | |
|---|--|------|-------|---|------------------|------------|------------------|---------------------|------------------|------------------|-----|-----------|-----|
| Ranks Per DIMM & Data Width | Memory Capacity Per DIMM (See the Note Below) | | | Speed (MT/s) and Voltage Validated by Slot per Channel (SPC) and DIMM Per Channel (DPC) | | | | | | | | | |
| | | | | 2 Slots Per Channel | | | | 3 Slots Per Channel | | | | | |
| | 1DPC | | 2DPC | | 1 DPC | | 2DPC | | 3DPC | | | | |
| | 1.35V | 1.5V | 1.35V | 1.5V | 1.35V | 1.5V | 1.35V | 1.5V | 1.35V | 1.5V | | | |
| SRx8 | 1GB | 2GB | 4GB | 1066, 1333 | 1066, 1333, 1600 | 1066, 1333 | 1066, 1333, 1600 | 1066, 1333 | 1066, 1333, 1600 | 1066, 1333, 1600 | N/A | 800, 1066 | |
| DRx8 | 2GB | 4GB | 8GB | 1066, 1333 | 1066, 1333, 1600 | 1066, 1333 | 1066, 1333, 1600 | 1066, 1333 | 1066, 1333, 1600 | 1066, 1333, 1600 | N/A | 800, 1066 | |
| SRx4 | 2GB | 4GB | 8GB | 1066, 1333 | 1066, 1333, 1600 | 1066, 1333 | 1066, 1333, 1600 | 1066, 1333 | 1066, 1333, 1600 | 1066, 1333, 1600 | N/A | 800, 1066 | |
| DRx4 | 4GB | 8GB | 16GB | 1066, 1333 | 1066, 1333, 1600 | 1066, 1333 | 1066, 1333, 1600 | 1066, 1333 | 1066, 1333, 1600 | 1066, 1333, 1600 | N/A | 800, 1066 | |
| QRx4 | 8GB | 16GB | 32GB | 800 | 1066 | 800 | 800 | 800 | 1066 | 800 | 800 | N/A | N/A |
| QRx8 | 4GB | 8GB | 16GB | 800 | 1066 | 800 | 800 | 800 | 1066 | 800 | 800 | N/A | N/A |

Note: For detailed information on memory support and updates, please refer to the SMC Recommended Memory List posted on our website at <http://www.supermicro.com/support/resources/mem.cfm>.

Populating LRDIMM (ECC) Memory Modules

| Intel E5-2600(v2) Series Processor LRDIMM Memory Support | | | | | | | | | | | |
|--|--|------|---|------------------|------------------|---------------------|------------------|------------------|------------------|------------------|------------------|
| Ranks Per DIMM & Data Width | Memory Capacity Per DIMM (See the Note Below) | | Speed (MT/s) and Voltage Validated by Slot per Channel (SPC) and DIMM Per Channel (DPC) | | | | | | | | |
| | | | 2 Slots Per Channel | | | 3 Slots Per Channel | | | | | |
| | 1DPC | | 2DPC | | 1DPC | | 2DPC | | 3DPC | | |
| | 1.35V | 1.5V | 1.35V | 1.5V | 1.35V | 1.5V | 1.35V | 1.5V | 1.35V | 1.5V | |
| QRx4 (DDP) | 16GB | 32GB | 1066, 1333, 1600 | 1066, 1333, 1866 | 1066, 1333, 1600 | 1066, 1333, 1600 | 1066, 1333, 1600 | 1066, 1333, 1600 | 1066, 1333, 1866 | 1066, 1333, 1600 | 1066, 1333, 1600 |
| 8Rx4 (QDP) | 32GB | 64GB | 1066 | 1066 | 1066 | 1066 | 1066 | 1066 | 1066 | 1066 | 1066 |

Note: For detailed information on memory support and updates, please refer to the SMC Recommended Memory List posted on our website at <http://www.supermicro.com/support/resources/mem.cfm>.

Intel E5-2600 Series Processor LRDIMM Memory Support

| Intel E5-2600 Series Processor LRDIMM Memory Support | | | | | | | | | | | |
|--|--|------|---|------------|-------|---------------------|-------|------------|-------|------------|------|
| Ranks Per DIMM & Data Width | Memory Capacity Per DIMM (See the Note Below) | | Speed (MT/s) and Voltage Validated by Slot per Channel (SPC) and DIMM Per Channel (DPC) | | | | | | | | |
| | | | 2 Slots Per Channel | | | 3 Slots Per Channel | | | | | |
| | 1DPC | | 2DPC | | 1DPC | | 2DPC | | 3DPC | | |
| | 1.35V | 1.5V | 1.35V | 1.5V | 1.35V | 1.5V | 1.35V | 1.5V | 1.35V | 1.5V | |
| QRx4 (DDP) | 16GB | 32GB | 1066 | 1066, 1333 | 1066 | 1066, 1333 | 1066 | 1066, 1333 | 1066 | 1066, 1333 | 1066 |
| QRx8 (QDP) | 8GB | 16GB | 1066 | 1066, 1333 | 1066 | 1066, 1333 | 1066 | 1066, 1333 | 1066 | 1066, 1333 | 1066 |

Note: For detailed information on memory support and updates, please refer to the SMC Recommended Memory List posted on our website at <http://www.supermicro.com/support/resources/mem.cfm>.

Notes and Restrictions

- For the memory modules to work properly, please install DIMMs of the same type, speed and operating frequency. Mixing of RDIMMs, UDIMMs and LRDIMMs is not allowed. Do not install both ECC and Non-ECC memory modules together.
- Using DDR3 DIMMs with different operating frequencies is not allowed. All channels in a system will run at the lowest common frequency.

5-6 Adding PCI Add-On Cards

The 6027R-E1CR12N can accommodate up to seven low-profile PCI add-on cards.

Installing an Add-on Card

1. Begin by removing the shield for the PCI slot you wish to populate.
2. Fully seat the card into the slot, pushing down with your thumbs evenly on both sides of the card.
3. Finish by using a screw to secure the top of the card shield to the chassis. The PCI slot shields protect the serverboard and its components from EMI and aid in proper ventilation, so make sure there is always a shield covering each unused slot.

5-7 Serverboard Details

Figure 5-4. X9DRi-LN4F+ Layout

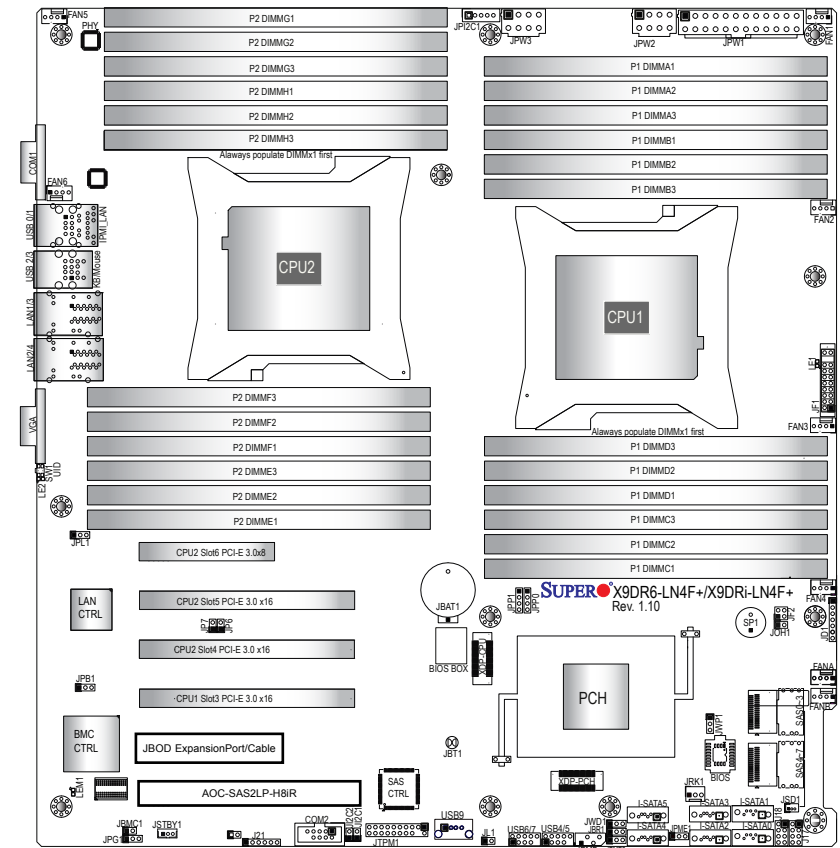

Notes

Jumpers not indicated are for test purposes only and should not have their settings changed.

The SSG-6027R-E1CR12N comes pre-installed with a Hardware RAID controller installed in PCI-E slot 1 and a JBOD expansion port installed in PCI-E slot 2. Serverboard SAS components shown in the figure above are not included on the X9DRi-LN4F+.

Please note that the PCI slots are enabled with the processors. "CPU2 Slot 4" indicates that the second CPU must be installed to the CPU2 socket to enable this PCI slot.

X9DRi-LN4F+ Quick Reference

| Jumper | Description | Default Setting |
|-------------------------------------|------------------------------|-----------------------|
| JBT1 | Clear CMOS | See Section 5-9 |
| J ² C1/J ² C2 | SMB to PCI-E Slots | Pins 2-3 (Normal) |
| JP6 | XDP (Extended Debug Port) | Open (Disabled) |
| JPB1 | BMC Enable/Disable | Pins 1-2 (Enabled) |
| JPG1 | VGA Enable/Disable | Pins 1-2 (Enabled) |
| JPL1 | GLAN1/GLAN2 Enable/Disable | Pins 1-2 (Enabled) |
| JPME1 | ME Recovery | Pins 2-3 (Normal) |
| JPME2 | Manufacture Mode Select | Pins 2-3 (Normal) |
| JPP0 | JTAG Scan | Pins 2-3 (CPU 1 only) |
| JPP1 | JTAG Scan | Pins 2-3 (CPU 2 only) |
| JWD | Watch Dog | Pins 1-2 (Reset) |
| JWP1 | Write Protect Enable/Disable | Pins 1-2 (Enabled) |

| Connector | Description |
|---------------------|---|
| COM1/COM2 | Backplane COM Port1/Front Accessible COM2 Header |
| FAN1~6, FANA, B | CPU/System Fan Headers |
| IPMB | 4-pin External BMC I ² C Header (for an IPMI Card) |
| I-SATA 0~5 | Intel SB SATA Connectors 0~5 |
| J17/J18 | Serial-Link General_Purpose IO Headers (T-SGPIO 1/2) |
| JBAT1 | Onboard Battery (See Chpt. 4 for Used Battery Disposal) |
| JD1 | Speaker/Power LED Indicator |
| JF1 | Front Panel Control Header |
| JPI ² C1 | System Management SMBbus I ² C Header |
| JITP0 | XDP CPU |
| JL1 | Chassis Intrusion |
| JOH1 | Overheat/Fan Fail LED |
| JPI ² C1 | Power Supply SMBbus I ² C Header |
| JPW1 | ATX 24-Pin Power Connector |
| JPW2/JPW3 | 12V 8-Pin Power Connectors |
| JSD1 | SATA DOM (Device On Module) Power Connector |
| JSTBY1 | Standby Header |
| JTPM1 | TPM (Trusted Platform Module)/Port 80 |
| LAN1/3, LAN2/4 | G-bit Ethernet Ports 1/3, 2/4 |

| | |
|------------------|---|
| (IPMI) LAN | IPMI_Dedicated LAN |
| SP1 | Onboard Buzzer (Internal Speaker) |
| USB 0/1 | Back Panel USB 0/1 |
| USB 2/3 | Back Panel USB 2/3 |
| USB 4/5, USB 6/7 | Front Panel Accessible USB Connections 4/5, 6/7 |
| USB 9 | Front Panel Type A USB 6, USB 7 Ports |
| UID Switch | UID (Unit Identifier) Switch |
| VGA | Backpanel VGA Port |

| LED | Description | State |
|------|-------------------|---|
| LE1 | Standby PWR LED | Solid Green (Standby Power On) |
| LE2 | UID LED | Blue: On (Windows OS), Blinking (Linux) |
| LEM1 | BMC Heartbeat LED | Blinking Green (Normal) |

5-8 Connector Definitions

Power Connectors

A 24-pin main power supply connector (JPW1) and two 8-pin CPU power connectors (JPW2/3) must be connected to the power supply. These power connectors meet the SSI EPS 12V specification. See the table on the right for pin definitions.

Warning: To provide adequate power supply to the serverboard, be sure to connect JPW1 and both JPW2 and JPW3 to the power supply. Failure to do so will void the manufacturer warranty on your power supply and serverboard.

| ATX Power 24-pin Connector Pin Definitions | | | |
|--|------------|-------|------------|
| Pin# | Definition | Pin # | Definition |
| 13 | +3.3V | 1 | +3.3V |
| 14 | -12V | 2 | +3.3V |
| 15 | COM | 3 | COM |
| 16 | PS_ON | 4 | +5V |
| 17 | COM | 5 | COM |
| 18 | COM | 6 | +5V |
| 19 | COM | 7 | COM |
| 20 | Res (NC) | 8 | PWR_OK |
| 21 | +5V | 9 | 5VSB |
| 22 | +5V | 10 | +12V |
| 23 | +5V | 11 | +12V |
| 24 | COM | 12 | +3.3V |

Secondary Power Connector

JPW2 and JPW3 must also be connected to the power supply. See the table on the right for pin definitions.

| +12V 8-pin Power Pin Definitions | |
|----------------------------------|------------|
| Pins | Definition |
| 1 - 4 | Ground |
| 5 - 8 | +12V |

Required Connection

Power Button

The Power On connection is on pins 1 and 2 of JF1. These should be connected to the chassis power button. See the table on the right for pin definitions.

| Power Button Pin Definitions (JF1) | |
|------------------------------------|--------------|
| Pin# | Definition |
| 1 | Power Signal |
| 2 | Ground |

Reset Button

The Reset Button connection is located on pins 3 and 4 of JF1 and attaches to the reset switch on the computer chassis. See the table on the right for pin definitions.

| Reset Button Pin Definitions (JF1) | |
|------------------------------------|------------|
| Pin# | Definition |
| 3 | Reset |
| 4 | Ground |

Power Fail LED

The Power Fail LED connection is located on pins 5 and 6 of JF1. Refer to the table on the right for pin definitions.

| PWR Fail LED Pin Definitions (JF1) | |
|------------------------------------|------------|
| Pin# | Definition |
| 5 | Vcc |
| 6 | Ground |

Overheat/Fan Fail LED (OH)

Connect an LED to the OH connection on pins 7 and 8 of JF1 to provide advanced warning of chassis overheating. Refer to the table on the right for pin definitions.

| OH/Fan Fail LED Pin Definitions (JF1) | | OH/Fan Fail Indicator Status | |
|---------------------------------------|------------|------------------------------|------------|
| Pin# | Definition | State | Definition |
| 7 | Vcc | Off | Normal |
| 8 | Ground | On | Overheat |
| | | Flash-ing | Fan Fail |

NIC2 (JLAN2) LED

The LED connections for JLAN2 are on pins 9 and 10 of JF1. Attach an LED cable to display network activity. See the table on the right for pin definitions.

| NIC2 LED Pin Definitions (JF1) | |
|--------------------------------|------------|
| Pin# | Definition |
| 9 | Vcc |
| 10 | Ground |

NIC1 (JLAN1) LED

The LED connections for JLAN1 are on pins 11 and 12 of JF1. Attach an LED cable to display network activity. See the table on the right for pin definitions.

| NIC1 LED Pin Definitions (JF1) | |
|--------------------------------|------------|
| Pin# | Definition |
| 11 | Vcc |
| 12 | Ground |

HDD LED

The HDD LED connection is located on pins 13 and 14 of JF1. This LED is used to display all IDE/SAS/SATA activity. See the table on the right for pin definitions.

| HDD LED Pin Definitions (JF1) | |
|-------------------------------|------------|
| Pin# | Definition |
| 13 | Vcc |
| 14 | HD Active |

Power On LED

The Power On LED connector is located on pins 15 and 16 of JF1 (use JLED for a 3-pin connector). This connection is used to provide LED indication of power being supplied to the system. See the table on the right for pin definitions.

| Power LED Pin Definitions (JF1) | |
|------------------------------------|------------|
| Pin# | Definition |
| 15 | 5V Stby |
| 16 | Control |

NMI Button

The non-maskable interrupt button header is located on pins 19 and 20 of JF1. Refer to the table on the right for pin definitions.

| NMI Button Pin Definitions (JF1) | |
|-------------------------------------|------------|
| Pin# | Definition |
| 19 | Control |
| 20 | Ground |

Fan Headers

There are eight fan headers on the serverboard, all of which are 4-pin fans. Pins 1-3 of the fan headers are backward compatible with the traditional 3-pin fans. (Fan speed control is supported with 4-pin fans only.) See the table on the right for pin definitions. The onboard fan speeds are controlled by Thermal Management (via Hardware Monitoring) under the Advanced Section in the BIOS.

| Fan Header Pin Definitions (FAN1-8) | |
|---|----------------|
| Pin# | Definition |
| 1 | Ground (Black) |
| 2 | +12V (Red) |
| 3 | Tachometer |
| 4 | PWR Modulation |

ATX PS/2 Keyboard and PS/2 Mouse Ports

The ATX PS/2 keyboard and the PS/2 mouse are located beside the USB0/1 ports. The mouse port is above the keyboard port. See the table on the right for pin definitions.

| PS/2 Keyboard and Mouse Port Pin Definitions | |
|--|------------|
| Pin# | Definition |
| 1 | Data |
| 2 | NC |
| 3 | Ground |
| 4 | VCC |
| 5 | Clock |
| 6 | NC |

Chassis Intrusion

The Chassis Intrusion header is designated JL1. Attach an appropriate cable from the chassis to inform you of a chassis intrusion when the chassis is opened.

| Chassis Intrusion Pin Definitions | |
|--------------------------------------|-----------------|
| Pin# | Definition |
| 1 | Intrusion Input |
| 2 | Ground |

Ethernet Ports

Four Ethernet ports are located on the I/O backplane. A dedicated IPMI LAN port is also included to provide KVM support for IPMI 2.0. These ports accept RJ45 type cables. Please refer to Section 5-11 for LAN LED information.



Internal Speaker

The internal speaker, located at SP1, can be used to provide audible indications for various beep codes. See the table on the right for pin definitions..

| Internal Buzzer (SP1) Pin Definition | | |
|---|-------------|---------------|
| Pin# | Definitions | |
| Pin 1 | Pos. (+) | Beep In |
| Pin 2 | Neg. (-) | Alarm Speaker |

Power LED/Speaker

On the JD1 header, pins 1-3 are for a power LED and pins 4-7 are for the speaker. Close pins 4-7 with a jumper to use an external speaker. If you wish to use the onboard speaker, please close pins 6-7. See the table on the right for speaker pin definitions.

| PWR LED Connector Pin Definitions | |
|--------------------------------------|-------------|
| Pin Setting | Definition |
| Pin 1 | Anode (+) |
| Pin2 | Cathode (-) |
| Pin3 | NA |

| Speaker Connector Pin Settings | |
|-----------------------------------|------------------|
| Pin Setting | Definition |
| Pins 4-7 | External Speaker |
| Pins 6-7 | Internal Speaker |

Overheat/Fan Fail LED

The JOH1 header is used to connect an LED indicator to provide warnings of chassis overheating and fan failure. This LED will blink when a fan failure occurs. Refer to the table on the right for pin definitions.

| OH/Fan Fail LED Status | |
|---------------------------|----------|
| State | Message |
| Solid | Overheat |
| Blinking | Fan Fail |

Serial Ports

Two serial ports are included on the serverboard. COM1 is a backpanel port and COM2 is a header located near the PCI-E slot 1. See the table on the right for pin definitions.

| Serial Port Pin Definitions (COM1/COM2) | | | |
|---|------------|-------|------------|
| Pin # | Definition | Pin # | Definition |
| 1 | DCD | 6 | DSR |
| 2 | RXD | 7 | RTS |
| 3 | TXD | 8 | CTS |
| 4 | DTR | 9 | RI |
| 5 | Ground | 10 | NC |

Universal Serial Bus (USB)

There are four Universal Serial Bus ports located on the I/O panel. In addition, there is one Type A port and two headers located on the serverboard. The headers can be used to provide front side USB access (cables not included). See the table on the right for pin definitions.

| Back Panel USB (USB 0/1/2/3) | | Type A USB Ports (USB9) | |
|------------------------------|-------------|-------------------------|------------|
| Pin# | Definitions | Pin# | Definition |
| 1 | +5V | 1 | Vcc |
| 2 | PO- | 2 | Data- |
| 3 | PO+ | 3 | Data+ |
| 4 | Ground | 4 | Ground |
| 5 | N/A | 5 | NA |

| USB Header Pin Definitions | | | |
|----------------------------|------------|--------|------------|
| USB4/6 | | USB5/7 | |
| Pin # | Definition | Pin # | Definition |
| 1 | +5V | 1 | +5V |
| 2 | PO- | 2 | PO- |
| 3 | PO+ | 3 | PO+ |
| 4 | Ground | 4 | Ground |
| 5 | N/A | 5 | Key |

SGPIO Headers

The SGPIO (Serial General Purpose Input/Output) headers are used to communicate with the enclosure management chip on the backplane. See the table on the right for pin definitions.

| SGPIO Header Pin Definitions | | | |
|------------------------------|------------|-----|------------|
| Pin# | Definition | Pin | Definition |
| 1 | NC | 2 | NC |
| 3 | Ground | 4 | DATA Out |
| 5 | Load | 6 | Ground |
| 7 | Clock | 8 | NC |

NC = No Connection

Overheat LED/Fan Fail (JOH1)

The JOH1 header is used to connect an LED to provide warning of chassis overheating or fan failure. This LED will blink to indicate a fan failure. Refer to the tables on right for LED status and pin definitions.

| OH/Fan Fail LED States | | Overheat LED Pin Definitions | |
|------------------------|----------|------------------------------|------------|
| State | Message | Pin# | Definition |
| Solid | Overheat | 1 | 5vDC |
| Blinking | Fan Fail | 2 | OH Active |

IPMB

A System Management Bus header for IPMI 2.0 is located at IPMB. Connect the appropriate cable here to use the IPMB I²C connection on your system.

| IPMB Header Pin Definitions | |
|-----------------------------|---------------|
| Pin# | Definition |
| 1 | Data |
| 2 | Ground |
| 3 | Clock |
| 4 | No Connection |

IPMB I²C Header

An SMB header for the IPMI (Intelligent Platform Management Interface) slot is designated J5. Connect the appropriate cable here to utilize this management feature on your system.

| IPMB Connector Pin Definitions | |
|--------------------------------|---------------|
| Pin# | Definition |
| 1 | Data |
| 2 | Ground |
| 3 | Clock |
| 4 | No Connection |

DOM Power Connector

A power connector for SATA DOM (Disk_On_Module) devices is located at JSD1. Connect an appropriate cable here to provide power support for your DOM devices.

| DOM PWR Pin Definitions | |
|-------------------------|------------|
| Pin# | Definition |
| 1 | +5V |
| 2 | Ground |
| 3 | Ground |

Power Supply SMBus I²C Header

The power System Management Bus header at JPI²C1 is used to monitor the status of the power supply, fan and system temperature. See the table on the right for pin definitions.

| PWR SMBus Header Pin Definitions | |
|----------------------------------|------------|
| Pin# | Definition |
| 1 | Clock |
| 2 | Data |
| 3 | PWR Fail |
| 4 | Ground |
| 5 | +3.3V |

Unit Identifier Switch

The UID Switch is located next to the LAN 2/4 ports on the backplane. The Rear UID LED (LE2) is located next to the UID switch. The control panel UID LED connection is on pins 7/8 of JF1. Connect a cable to pin 8 on JF1 for Front Panel UID LED indication. When you press the UID switch, both the rear UID LED and control panel UID LED indicators will be turned on. Press the UID switch again to turn off both LED Indicators. These indicators provide easy identification of a system unit that may be in need of service.

| UID Switch | |
|------------|------------|
| Pin# | Definition |
| 1 | Ground |
| 2 | Ground |
| 3 | Button In |
| 4 | Ground |

| UID LED (LE2) Status | | |
|----------------------|------------|-----------------|
| Color/State | OS | Status |
| Blue: On | Windows OS | Unit Identified |
| Blue: Blinking | Linux OS | Unit Identified |

Note: UID can also be triggered via IPMI. For more information on IPMI, please refer to the IPMI User's Guide posted on our Website @<http://www.supermicro.com>.

Power SMB (I²C) Connector

Power System Management Bus (I²C) Connector (JPI²C1) monitors power supply, fan and system temperatures. See the table on the right for pin definitions.

| PWR SMB Pin Definitions | |
|-------------------------|------------|
| Pin# | Definition |
| 1 | Clock |
| 2 | Data |
| 3 | PWR Fail |
| 4 | Ground |
| 5 | +3.3V |

TPM Header/Port 80

A Trusted Platform Module/Port 80 header is located at JTPM1 to provide TPM support and a Port 80 connection. Use this header to enhance system performance and data security. See the table on the right for pin definitions.

| TPM/Port 80 Header Pin Definitions | | | |
|------------------------------------|------------|-------|-------------|
| Pin # | Definition | Pin # | Definition |
| 1 | LCLK | 2 | GND |
| 3 | LFRAME# | 4 | <(KEY)> |
| 5 | LRESET# | 6 | +5V (X) |
| 7 | LAD 3 | 8 | LAD 2 |
| 9 | +3.3V | 10 | LAD1 |
| 11 | LAD0 | 12 | GND |
| 13 | SMB_CLK4 | 14 | SMB_DAT4 |
| 15 | +3V_DUAL | 16 | SERIRQ |
| 17 | GND | 18 | CLKRUN# (X) |
| 19 | LPCPD# | 20 | LDRQ# (X) |

5-9 Jumper Settings

Explanation of Jumpers

To modify the operation of the serverboard, jumpers can be used to choose between optional settings. Jumpers create shorts between two pins to change the function of the connector. Pin 1 is identified with a square solder pad on the printed circuit board. See the serverboard layout pages for jumper locations.

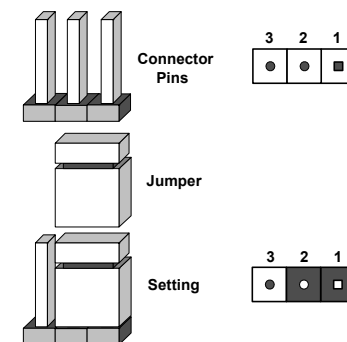

Note: On a two-pin jumper, "Closed" means the jumper is on both pins and "Open" means the jumper is either on only one pin or completely removed.

CMOS Clear

JBT1 is used to clear CMOS (which will also clear any passwords). Instead of pins, this jumper consists of contact pads to prevent accidentally clearing the contents of CMOS.

To clear CMOS,

1. First power down the system and unplug the power cord(s).
2. With the power disconnected, short the CMOS pads with a metal object such as a small screwdriver.
3. Remove the screwdriver (or shorting device).
4. Reconnect the power cord(s) and power on the system.

Note: Do not use the PW_ON connector to clear CMOS.

VGA Enable/Disable

JPG1 allows you to enable or disable the VGA port. The default position is on pins 1 and 2 to enable VGA. See the table on the right for jumper settings.

| VGA Enable/Disable Jumper Settings | |
|------------------------------------|------------|
| Jumper Setting | Definition |
| Pins 1-2 | Enabled |
| Pins 2-3 | Disabled |

GLAN Enable/Disable

JPL1 enables or disables the GLAN ports on the serverboard. See the table on the right for jumper settings. The default setting is Enabled.

| GLAN Enable Jumper Settings | |
|-----------------------------|------------|
| Jumper Setting | Definition |
| Pins 1-2 | Enabled |
| Pins 2-3 | Disabled |

I²C Bus to PCI-Exp. Slots

Jumpers JI²C1 and JI²C2 allow you to connect the System Management Bus (I²C) to the PCI-Express slots. The default setting is pins 2-3 (Disabled.) Both jumpers must be set to the same setting. See the table on the right for jumper settings.

| I ² C to PCI-E Slots Jumper Settings | |
|---|------------|
| Jumper Setting | Definition |
| Pins 1-2 | Enabled |
| Pins 2-3 | Disabled |

Write_Protect Enable

Close pins 1/2 of JWP1 to enable write protect support via software-control. Enabling this jumper will enhance system security and data integrity. See the table on the right for jumper settings.

| Write_Protect (JWP1) Jumper Settings | |
|--------------------------------------|--|
| Jumper Setting | Definition |
| Open | Write Protect Disabled |
| Pins 1-2 | Write Protect via Software Control (Default) |
| Pins 2-3 | Write Protect Enabled |

BMC Enable

Jumper JPB1 allows you to enable the embedded the Winbond WPC-M450R BMC (Baseboard Management) Controller to provide IPMI 2.0/ KVM support on the serverboard. See the table on the right for jumper settings.

| BMC Enable Jumper Settings | |
|----------------------------|------------|
| Jumper Setting | Definition |
| Pins 1-2 | BMC Enable |
| Pins 2-3 | Normal |

Manufacturer's Mode

Jumper JPME2 allows the user to flash the system firmware from a host server in order to modify system settings. Close this jumper to bypass SPI flash security, and force ME into recovery mode in order to use recovery jumpers. See the table on the right for jumper settings. .

| ME Mode Select Jumper Settings | |
|--------------------------------|---------------------|
| Jumper Setting | Definition |
| Pins 1-2 | Manufacturer's Mode |
| Pins 2-3 | Normal |

ME Recovery

Close Jumper JPME1 to use ME Firmware Recovery mode, which will limit system activities to support essential functions only. There will be no power use restrictions. In single operational mode, online upgrade will be available via the Recovery mode. See the table on the right for jumper settings.

| ME Recovery Jumper Settings | |
|-----------------------------|-------------|
| Jumper Setting | Definition |
| Closed | ME Recovery |
| Open | Normal |

XDP Clock Enable

Close Jumper JP6 to enable XDP (Extended Debug Port) support, which will increase system debug resources and extend JTAG by using two separate clock domain scan chains for system scan optimization. If this jumper is set to "Off", CPU1 clock domain chain will be used in system scanning. See the table on the right for jumper settings.

| XDP Clock Enable Jumper Settings | |
|----------------------------------|--|
| Jumper Setting | Definition |
| Closed | Enabled (Two separate clock scan chains used in system scan) |
| Open | Disabled (CUP1 Clock Scan Chain is used in system scan) |

Watch Dog Enable/Disable

Jumper JWD controls the Watch Dog function. Watch Dog is a system monitor that can reboot the system when a software application hangs. Jumping pins 1-2 will cause WD to reset the system if an application hangs. Jumping pins 2-3 will generate a non-maskable interrupt signal for the application that hangs. See the table on the right for jumper settings. Watch Dog must also be enabled in BIOS.

| Watch Dog Jumper Settings | |
|---------------------------|------------|
| Jumper Setting | Definition |
| Pins 1-2 | Reset |
| Pins 2-3 | NMI |
| Open | Disabled |

Note: When enabled, the user needs to write their own application software in order to disable the Watch Dog Timer.

JTAG Scan

The JTAG scan jumpers (JPP0/JPP1) allow the user to configure JTAG scan settings for system debugging. See the tables on the right for jumper settings.

| JTAG Scan (JPP0) Jumper Settings | |
|----------------------------------|-----------------------------|
| Jumper Setting | Definition |
| Pins 1-2, 3-4 | including CPU2 in JTAG Scan |
| Pins 2-3 | JTAG Scan: CPU1 only |

| JTAG Scan (JPP1) Jumper Settings | |
|----------------------------------|-----------------------------|
| Jumper Setting | Definition |
| Pins 1-2, 3-4 | including CPU1 in JTAG Scan |
| Pins 2-3 | JTAG Scan: CPU2 only |

5-10 Onboard Indicators

LAN LEDs

The Ethernet ports (located beside the VGA port) have two LEDs. On each port, the yellow LED flashes to indicate activity while the other LED may be green, amber or off to indicate the speed of the connection. See the table on the right for the functions associated with the connection speed LED.



| JLAN1/2 LED (Connection Speed Indicator) | |
|--|---------------|
| LED Color | Definition |
| Off | NC or 10 Mbps |
| Green | 100 Mbps |
| Amber | 1 Gbps |

IPMI Dedicated LAN LEDs

An additional IPMI Dedicated LAN is also located on the I/O backplane. The amber LED on the right indicates activity, while the green LED on the left indicates the speed of the connection. See the table at right for more information.

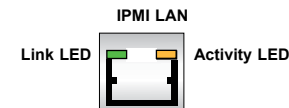

| IPMI LAN Link LED (Left) & Activity LED (Right) | | |
|---|-----------------|------------|
| LED | Status | Definition |
| Link (Left) | Green: Solid | 100 Mbps |
| Activity (Right) | Amber: Blinking | Active |

Onboard Power LED (LE1)

An Onboard Power LED is located at LE1. This LED Indicator is lit when the system is on. Be sure to unplug the power cable before removing or adding any components. See the table on the right for more details.

| Onboard PWR LED Indicator | |
|---------------------------|--------------------------------------|
| LED Color | Status |
| Off | System Off (PWR cable not connected) |
| Green | System On |
| Green: Flashing Quickly | ACPI S1 State |
| Green: Flashing Slowly | ACPI S3 (STR) State |

Rear UID LED

The rear UID LED is designated LE2. This LED is used in conjunction with the rear UID switch to provide easy identification of a system.

| UID LED Status | | |
|----------------|------------|-----------------|
| Color/State | OS | Status |
| Blue: On | Windows OS | Unit Identified |
| Blue: Blinking | Linux OS | Unit Identified |

BMC Heartbeat LED

A BMC Heartbeat LED is located at LEM1 on the serverboard. When blinking, BMC is functioning normally.

| BMC Heartbeat LED | |
|-------------------|-----------------------|
| LED | Definition |
| D1 | Blinking: BMC: Normal |

5-11 SATA Ports

Serial ATA Ports

There are six Serial ATA Ports (I-SATA0~I-SATA 5) located on the serverboard, including four SATA2 ports and two SATA3 ports. These ports provide serial-link signal connections, which are faster than Parallel ATA. See the table on the right for pin definitions.

| SATA Port Pin Definitions | | | |
|---------------------------|------------|-----|------------|
| Pin# | Definition | Pin | Definition |
| 1 | Ground | 2 | TXP |
| 3 | TXN | 4 | Ground |
| 5 | RXN | 6 | RXP |
| 7 | Ground | | |

Note: For more information on SATA HostRAID configuration, please refer to the Intel SATA HostRAID User's Guide posted on our Website @ <http://www.supermicro.com>..

5-12 Installing Software

After the hardware has been installed, you should first install the operating system and then the drivers. The necessary drivers are all included on the Supermicro CDs that came packaged with your serverboard.



Driver/Tool Installation Display Screen

Note: Click the icons showing a hand writing on paper to view the readme files for each item. Click the computer icons to the right of these items to install each item (from top to the bottom) one at a time. **After installing each item, you must re-boot the system before moving on to the next item on the list.** The bottom icon with a CD on it allows you to view the entire contents of the CD.

SuperDoctor III

The SuperDoctor® III program is a web-based management tool that supports remote management capability. It includes Remote and Local Management tools. The local management is called SD III Client. The SuperDoctor III program included on the CD-ROM that came with your serverboard allows you to monitor the environment and operations of your system. SuperDoctor III displays crucial system information such as CPU temperature, system voltages and fan status. See the Figure below for a display of the SuperDoctor III interface.

Note: The default User Name and Password for SuperDoctor III is ADMIN / ADMIN.

Note: When SuperDoctor is first installed, it adopts the temperature threshold settings that have been set in BIOS. Any subsequent changes to these thresholds must be made within SuperDoctor, as the SuperDoctor settings override the BIOS settings. To set the BIOS temperature threshold settings again, you would first need to uninstall SuperDoctor.

Supero Doctor III Interface Display Screen (Health Information)



Supero Doctor III Interface Display Screen (Remote Control)



Note: The SuperDoctor III program and User's Manual can be downloaded from the Supermicro web site at <http://www.supermicro.com/products/accessories/software/SuperDoctorIII.cfm>.

For Linux, we recommend using SuperDoctor II.

Notes

Chapter 6

Advanced Chassis Setup

This chapter covers the steps required to install components and perform maintenance on the SC826BE1C-R920LPB chassis. For component installation, follow the steps in the order given to eliminate the most common problems encountered. If some steps are unnecessary, skip ahead to the step that follows.

Tools Required: The only tool you will need to install components and perform maintenance is a Philips screwdriver.

6-1 Static-Sensitive Devices

Electrostatic discharge (ESD) can damage electronic components. To prevent damage to any printed circuit boards (PCBs), it is important to handle them very carefully. The following measures are generally sufficient to protect your equipment from ESD damage.

Precautions

- Use a grounded wrist strap designed to prevent static discharge.
- Touch a grounded metal object before removing any board from its antistatic bag.
- Handle a board by its edges only; do not touch its components, peripheral chips, memory modules or gold contacts.
- When handling chips or modules, avoid touching their pins.
- Put the serverboard, add-on cards and peripherals back into their antistatic bags when not in use.
- For grounding purposes, make sure your computer chassis provides excellent conductivity between the power supply, the case, the mounting fasteners and the serverboard.

Unpacking

The serverboard is shipped in antistatic packaging to avoid static damage. When unpacking the board, make sure the person handling it is static protected.

Figure 6-1. Front and Rear Chassis Views

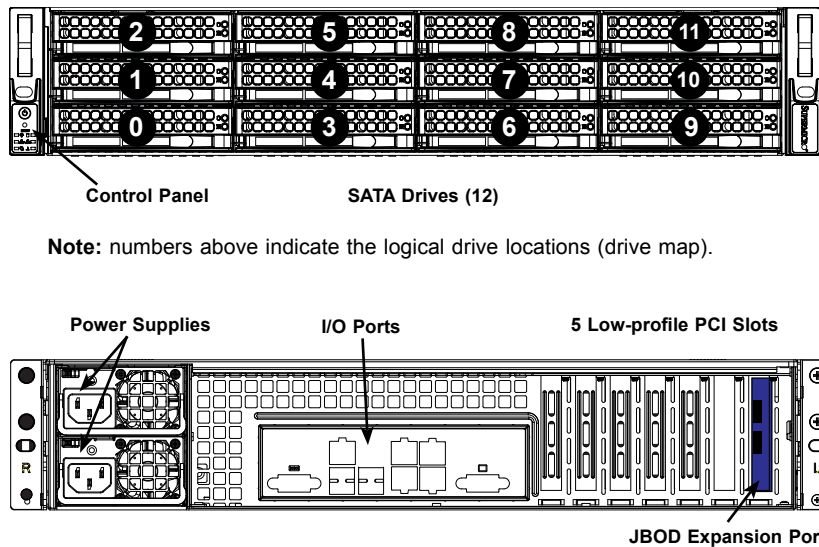

6-2 Control Panel

The control panel (located on the front of the chassis) must be connected to the JF1 connector on the serverboard to provide you with system status indications. A ribbon cable has bundled these wires together to simplify the connection. Connect the cable from JF1 on the serverboard to the Control Panel PCB (printed circuit board). Make sure the red wire plugs into pin 1 on both connectors. Pull all excess cabling out of the airflow path. The LEDs inform you of system status.

See Chapter 3 for details on the LEDs and the control panel buttons. Details on JF1 can be found in Chapter 5.

6-3 Accessing the Inside of the Chassis

Some maintenance will require accessing the inside of the server.

Removing the Chassis Cover (Figure 6-2)

1. Remove the two screws from the sides of the chassis cover.
2. Press both release tabs at the same time to unlock the cover.
3. Slide the cover toward the rear of the chassis.
4. Lift the cover off the chassis.

Figure 6-2. Removing the Chassis Cover

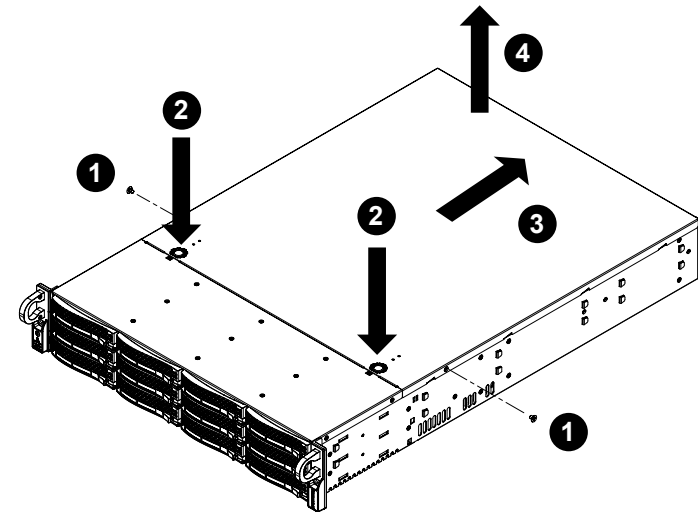

6-4 System Fans

Three 8-cm hot-swap fans provide the cooling for the system. It is very important that the chassis top cover is properly installed and making a good seal in order for the cooling air to circulate properly through the chassis and cool the components.

System Fan Failure

Fan speed is controlled by system temperature via IPMI. If a fan fails, the remaining fans will ramp up to full speed and the overheat/fan fail LED on the control panel will turn on. Replace any failed fan at your earliest convenience with the same type and model (the system can continue to run with a failed fan). Remove the top chassis cover while the system is still running to determine which of the fans has failed.

Caution: Except for short periods of time, do not operate the server without the chassis cover in place. The cover must be in place to allow proper airflow and prevent overheating.

Replacing System Fans

1. If necessary, open the chassis while the power is running to determine which fan requires changing. (Never run the server for an extended period of time with the chassis open.)
2. Press the fan release tab to lift the failed fan from the chassis and pull it completely from the chassis.
3. Place the new fan into the vacant space in the housing, while making sure the arrows on the top of the fan (indicating air direction) point in the same direction as the arrows on the other fans.
4. Power up the system and check that the fan is working properly before replacing the chassis cover.

Figure 6-3. Replacing System Cooling Fans

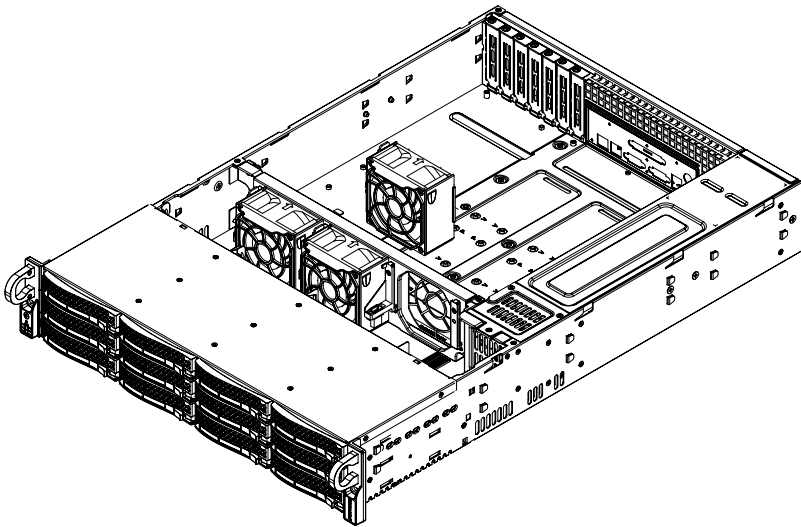

6-5 Air Shroud

Air shrouds concentrate airflow to maximize fan efficiency. The SC826 chassis air shroud does not require screws to set up.

Installing the Air Shroud

1. Lay the chassis on a flat, stable surface and remove the chassis cover.
2. If necessary, move any cables that interfere with the air shroud placement.
3. Place the air shroud in the chassis. The air shroud fits just behind the two fans closest to the power supply. Slide the air shroud into the grooves just behind the fan rack.
4. If necessary, the perforated tabs on either side of the air shroud may be removed to ensure a proper fit.

Figure 6-4. Replacing the Air Shroud

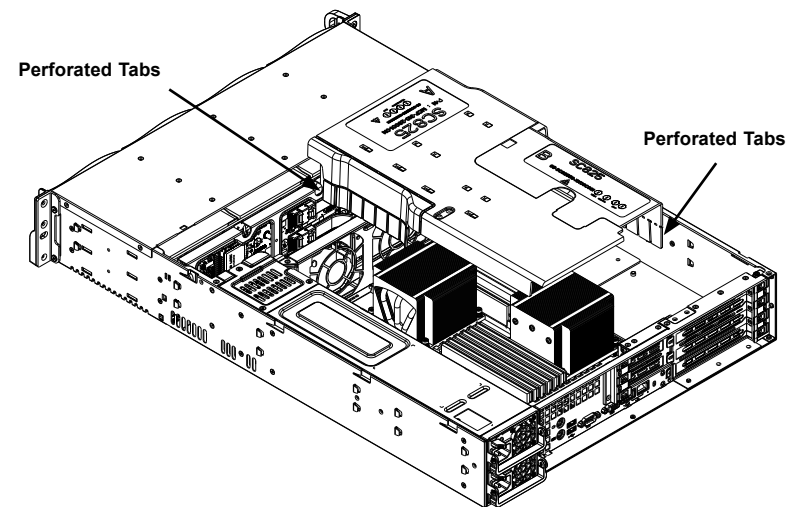

6-6 Drive Bay Installation/Removal

Accessing the Drive Bays

You do not need to access the inside of the chassis or remove power to replace or swap hard drives. Proceed to the next step for instructions.

Note: Refer to the following ftp site for setup guidelines: <ftp://ftp.supermicro.com/driver/SAS/LSI/LSI_SAS_EmbMRAID_SWUG.pdf> and Supermicro's web site for additional information <<http://www.supermicro.com/support/manuals/>>.

SAS/SATA Drive Installation

These drives are mounted in carriers to simplify their installation and removal from the chassis. The carriers also help promote proper airflow for the drives. For this reason, even empty carriers without hard drives installed must remain in the chassis.

Removing a Drive Carrier

1. Push the release button located beside the drive's LEDs.
2. Swing the handle fully out and use it to pull the drive carrier straight out (see Figure 6-5).

Mounting a Drive in a Drive Carrier

1. To add a new hard drive, install the drive into the carrier with the printed circuit board side facing down so that the mounting holes align with those in the carrier.
2. Secure the drive to the carrier with four screws, as shown in Figure 6-5.

Caution: Enterprise level hard disk drives are recommended for use in Supermicro chassis and servers. For information on recommended HDDs, visit the Supermicro website at <http://www.supermicro.com/products/nfo/storage.cfm>

Figure 6-5. Removing a Hard Drive Carrier

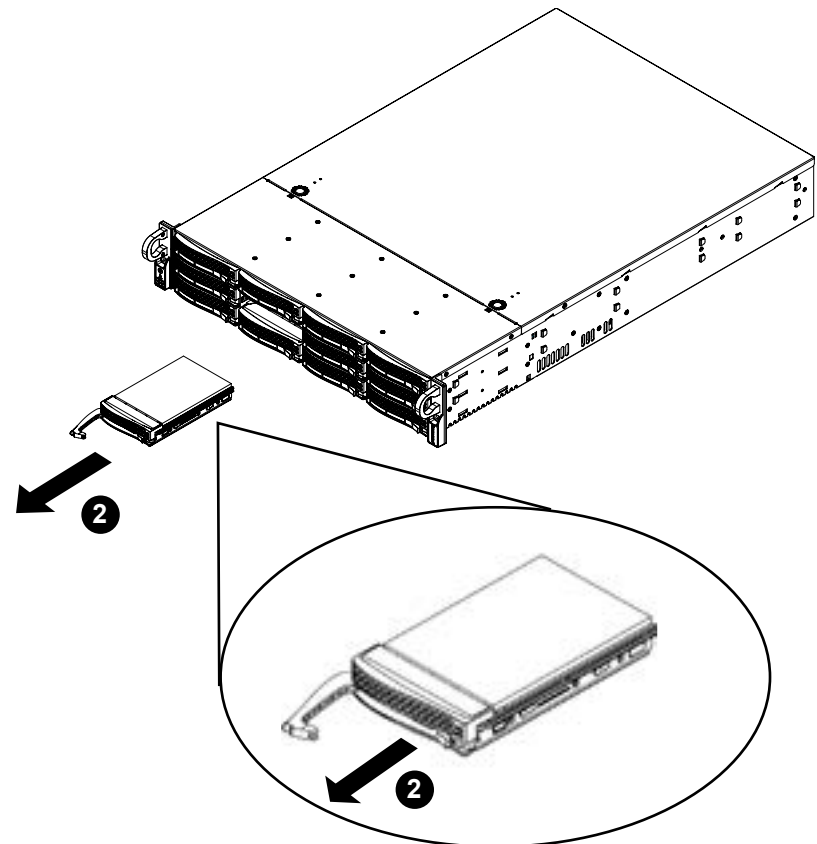

Caution: Regardless of how many hard drives are installed, all drive carriers must remain in the drive bays to maintain proper airflow.

Figure 6-6. Mounting a Drive in a Carrier

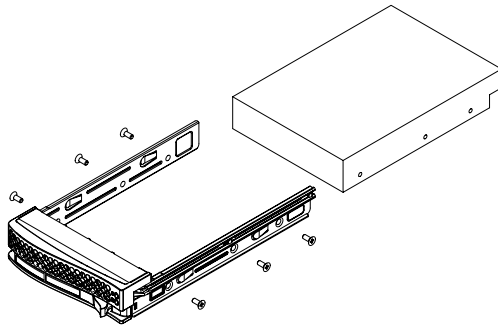

Hard Drive Backplane

The hard drives plug into a backplane that provides power, drive ID and bus termination. The supplied RAID controller provides hot-swap capability with SAS/SATA drive state indication. The backplane is already preconfigured, so no jumper or switch configurations are required.

Figure 6-7. Backplane

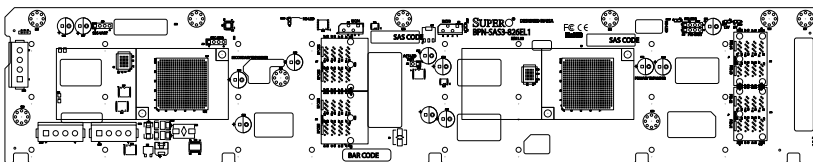

Caution: Use care when working around the backplane. Do not touch the backplane with any metal objects and make sure no ribbon cables touch the backplane or obstruct the holes, which aid in proper airflow.

6-7 Power Supply

The 6027R-E1CR12N has a 920 watt redundant, hot-plug power supply consisting of two power modules. Each power supply module has an auto-switching capability, which enables it to automatically sense and operate at a 100V - 240V input voltage.

Power Supply Failure

An amber light will be illuminated on the power supply when the power is off. An illuminated green light indicates that the power supply is operating. If either of the two power supply modules fail, the other module will take the full load and allow the system to continue operation without interruption. The Power Fail LED on the front control panel will illuminate and remain on until the failed unit has been replaced.

Replacement units can be ordered directly from Supermicro. The power supply units have a hot-swap capability, meaning you can replace the failed unit without powering down the system.

Removing/Replacing the Power Supply

You do not need to shut down the system to replace a power supply unit. The backup power supply module will keep the system up and running while you replace the failed hot-swap unit. Replace with the same model (see part number in the Appendix), which can be ordered directly from Supermicro.

Removing the Power Supply (Figure 6-8)

1. First unplug the AC power cord from the failed power supply module.
2. Depress the locking tab on the power supply module.
3. Use the handle to pull it straight out with the rounded handle.

Installing a New Power Supply

1. Replace the failed hot-swap unit with another identical power supply unit.
2. Push the new power supply unit into the power bay until you hear a click.
3. Secure the locking tab on the unit.
4. Finish by plugging the AC power cord back into the unit.

Figure 6-8. Removing the Power Supply

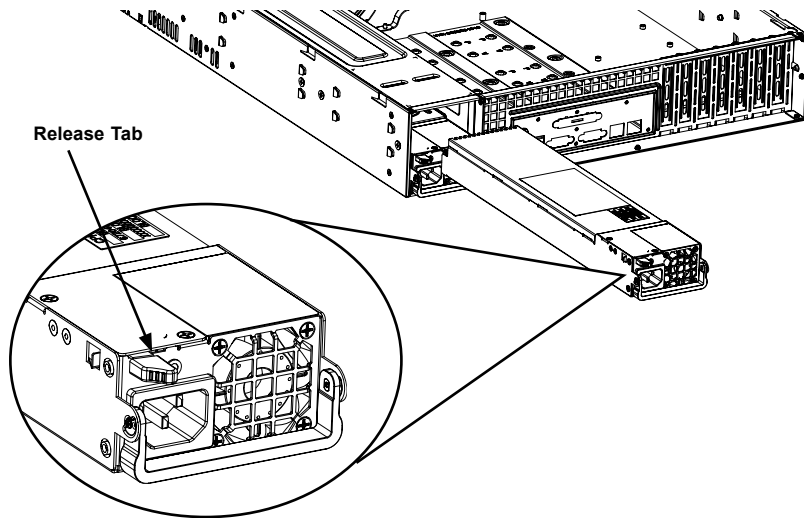

6-8 Attaching a JBOD Expansion Chassis

The SSG-6027R-E1CR12N features a dual JBOD expansion port. The JBOD attachment will vary depending on the specific JBOD chassis that is being connected. The JBOD image below is provided for illustrative purposes only; port location and routing specifications are subject to change. Please follow the instructions provided with the JBOD.

Figure 6-9. JBOD Expansion Ports

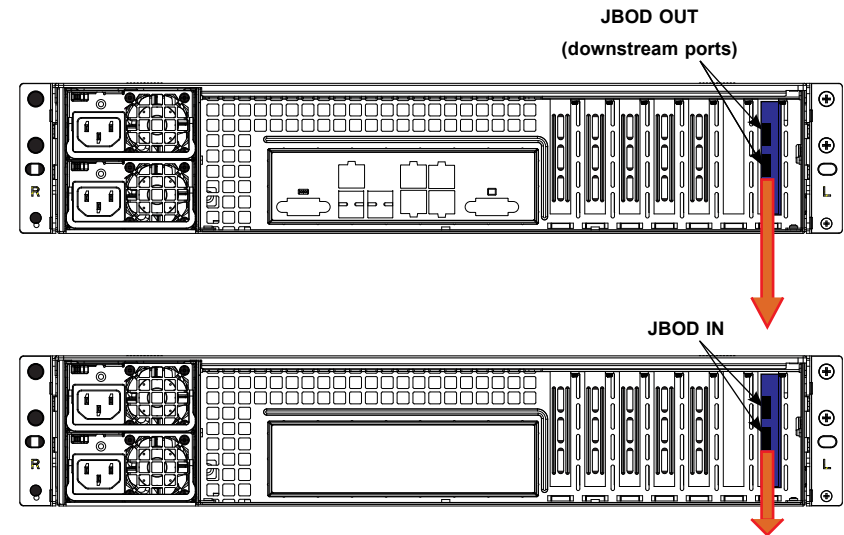

Notes

Chapter 7

BIOS

7-1 Introduction

This chapter describes the AMI BIOS Setup utility for the X9DR6-LN4F+/X9DRi-LN4F+. It also provides the instructions on how to navigate the AMI BIOS Setup utility screens. The AMI ROM BIOS is stored in a Flash EEPROM and can be easily updated.

Starting BIOS Setup Utility

To enter the AMI BIOS Setup utility screens, press the <F2> key while the system is booting up.

In most cases, the <F2> key is used to invoke the AMI BIOS setup screen. There are a few cases when other keys are used, such as <F8>, <F9>, etc.

Each main BIOS menu option is described in this manual. The Main BIOS setup menu screen has two main frames. The left frame displays all the options that can be configured. Grayed-out options cannot be configured. Options in blue can be configured by the user. The right frame displays the key legend. Above the key legend is an area reserved for a text message. When an option is selected in the left frame, it is highlighted in white. Often a text message will accompany it.

The AMI BIOS has default text messages built in. The manufacturer retains the option to include, omit, or change any of these text messages.

The AMI BIOS Setup utility uses a key-based navigation system called "hot keys." Most of the AMI BIOS setup utility "hot keys" can be used at any time during setup navigation. These keys include <F1>, <F10>, <Enter>, <ESC>, arrow keys, etc.

Options printed in **Bold** are default settings.

How To Change the Configuration Data

The configuration data that determines the system parameters may be changed by entering the AMI BIOS Setup utility. This Setup utility can be accessed by pressing <F2> at the appropriate time during system boot.

Note: For AMI UEFI BIOS Recovery, please refer to the UEFI BIOS Recovery User Guide posted @<http://www.supermicro.com/support/manuals/>.

Starting the Setup Utility

Normally, the only visible Power-On Self-Test (POST) routine is the memory test. As the memory is being tested, press the <F2> key to enter the main menu of the AMI BIOS Setup utility. From the main menu, you can access the other setup screens. An AMI BIOS identification string is displayed at the left bottom corner of the screen below the copyright message.



Warning! Do not upgrade the BIOS unless your system has a BIOS-related issue. Flashing the wrong BIOS can cause irreparable damage to the system. In no event shall the manufacturer be liable for direct, indirect, special, incidental, or consequential damage arising from a BIOS update. If you have to update the BIOS, do not shut down or reset the system while the BIOS is being updated to avoid possible boot failure.

7-2 Main Setup

When you first enter the AMI BIOS Setup utility, you will enter the Main setup screen. You can always return to the Main setup screen by selecting the Main tab on the top of the screen. The Main BIOS Setup screen is shown below.



The AMI BIOS main menu displays the following information:

System Date

This item displays the system date.

System Time

This item displays the system Time.

Supermicro X9DR6-LN4+

SMC Version

This item displays the SMC version of the BIOS ROM used in this system.

SMC Build Date

This item displays the date that the BIOS Setup utility was built.

Memory Information

Total Memory

This displays the amount of memory that is available in the system.

7-3 Advanced Setup Configurations

Use the arrow keys to select Boot Setup and press <Enter> to access the following submenu items.



► Boot Features

Quiet Boot

This feature allows the user to select bootup screen display between POST messages and the OEM logo. Select Disabled to display the POST messages. Select Enabled to display the OEM logo instead of the normal POST messages. The options are **Enabled** and **Disabled**.

AddOn ROM Display Mode

Use this item to set the display mode for the Option ROM. Select Keep Current to use the current AddOn ROM Display setting. Select Force BIOS to use the Option ROM display mode set by the system BIOS. The options are **Force BIOS** and Keep Current.

Bootup Num-Lock

Use this feature to set the Power-on state for the Numlock key. The options are Off and **On**.

Wait For 'F1' If Error

Select Enabled to force the system to wait until the 'F1' key is pressed if an error occurs. The options are Disabled and **Enabled**.

Interrupt 19 Capture

Interrupt 19 is the software interrupt that handles the boot disk function. When this item is set to Enabled, the ROM BIOS of the host adaptors will "capture" Interrupt 19 at bootup and allow the drives that are attached to these host adaptors to function as bootable disks. If this item is set to Disabled, the ROM BIOS of the host adaptors will not capture Interrupt 19, and the drives attached to these adaptors will not function as bootable devices. The options are **Enabled** and Disabled.

Power Configuration**Watch Dog Function**

If enabled, the Watch Dog timer will allow the system to reboot when it is inactive for more than 5 minutes. The options are Enabled and **Disabled**.

Power Button Function

If this feature is set to Instant_Off, the system will power off immediately as soon as the user presses the power button. If this feature is set to 4_Second_Override, the system will power off when the user presses the power button for 4 seconds or longer. The options are **Instant_Off** and 4_Second_Override.

Restore on AC Power Loss

Use this feature to set the power state after a power outage. Select Power-Off for the system power to remain off after a power loss. Select Power-On for the system power to be turned on after a power loss. Select Last State to allow the system to resume its last state before a power loss. The options are Power-On, Power-Off and **Last State**.

CPU Configuration

This submenu displays the information of the CPU as detected by the BIOS. It also allows the user to configuration CPU settings.

►Socket 0 CPU Information

This submenu displays the following information regarding the CPU installed in Socket 0.

- Type of CPU
- CPU Signature
- Microcode Patch
- CPU Stepping
- Maximum CPU Speed
- Minimum CPU Speed
- Processor Cores
- Intel HT (Hyper-Threading) Technology
- Intel VT-x Technology
- Intel SMX Technology
- L1 Data Cache
- L1 Code Cache
- L2 Cache
- L3 Cache

Socket 1

This item displays if a CPU is installed in Socket 1.

CPU Speed

This item displays the speed of the CPU installed in Socket 0.

64-bit

This item indicates if the CPU installed in Socket 0 supports 64-bit technology.

Clock Spread Spectrum

Select Enable to enable Clock Spectrum support, which will allow the BIOS to monitor and attempt to reduce the level of Electromagnetic Interference caused by the components whenever needed. The options are **Disabled** and **Enabled**.

Hyper-threading

Select Enabled to support Intel Hyper-threading Technology to enhance CPU performance. The options are **Enabled** and **Disabled**.

Active Processor Cores

Set to Enabled to use a processor's second core and above. (Please refer to Intel's website for more information.) The options are **All**, **1** and **2**.

Limit CPUID Maximum

This feature allows the user to set the maximum CPU ID value. Enable this function to boot the legacy operating systems that cannot support processors with extended CPUID functions. The options are **Enabled** and **Disabled** (for the Windows OS).

Execute-Disable Bit Capability (Available if supported by the OS & the CPU)

Select Enabled to enable the Execute Disable Bit which will allow the processor to designate areas in the system memory where an application code can execute and where it cannot, thus preventing a worm or a virus from flooding illegal codes to overwhelm the processor or damage the system during an attack. The default is **Enabled**. (Refer to Intel and Microsoft Web sites for more information.)

Intel® AES-NI

Select Enable to use the Intel Advanced Encryption Standard (AES) New Instructions (NI) to ensure data security. The options are **Enabled** and **Disabled**.

Hardware Prefetcher (Available when supported by the CPU)

If set to Enabled, the hardware prefetcher will prefetch streams of data and instructions from the main memory to the L2 cache to improve CPU performance. The options are **Disabled** and **Enabled**.

Adjacent Cache Line Prefetch (Available when supported by the CPU)

The CPU prefetches the cache line for 64 bytes if this feature is set to **Disabled**. The CPU prefetches both cache lines for 128 bytes as comprised if this feature is set to **Enabled**.

L1 Data Prefetch (Available when supported by the CPU)

Select Enabled to enable Level 1 data prefetch support to enhance system performance. For DP/MP servers, enable or disable this feature for system enhancement

based on the specifications of the application running in the system at the time. The options are **Disabled** and **Enabled**.

Intel® Virtualization Technology (Available when supported by the CPU)

Select Enabled to support Intel Virtualization Technology, which will allow one platform to run multiple operating systems and applications in independent partitions, creating multiple "virtual" systems in one physical computer. The options are **Enabled** and **Disabled**.

Note: If there is any change to this setting, you will need to power off and restart the system for the change to take effect. Please refer to Intel's website for detailed information.)

► CPU Power Management Configuration

This submenu allows the user to configure the following CPU Power Management settings.

Power Technology

Select Energy Efficiency to support power-saving mode. Select Custom to customize system power settings. Select Disabled to disable power-saving settings. The options are **Disabled**, **Energy Efficiency**, and **Custom**.

EIST

EIST (Enhanced Intel SpeedStep Technology) allows the system to automatically adjust processor voltage and core frequency to reduce power consumption and heat dissipation. The options are **Disabled (GV3 Disabled)**, and **Enabled (GV3 Enabled)**. (**Note:** GV3 is Intel Speedstep support used on older platforms.) Please refer to Intel's website for detailed information.)

Turbo Mode (Available when Intel® EIST Technology is enabled)

Select Enabled to use the Turbo Mode to boost system performance. The options are **Enabled** and **Disabled**.

P-State Coordination

This feature allows the user to change the P-State (Power-Performance State) coordination type. P-State is also known as "SpeedStep" for Intel processors. Select **HW_ALL** to change the P-State coordination type for hardware components only. Select **SW_ALL** to change the P-State coordination type for all software installed in the system. Select **SW_ANY** to change the P-State coordination type for a software program in the system. The options are **HW_All**, **SW_ALL**, and **SW_ANY**.

CPU C3 Report

Select Enabled to allow the BIOS to report the CPU C3 State (ACPI C2) to the operating system. During the CPU C3 State, the CPU clock generator is turned off. The options are Enabled and **Disabled**.

CPU C6 Report

Select Enabled to allow the BIOS to report the CPU C6 State (ACPI C3) to the operating system. During the CPU C6 State, the power to all cache is turned off. The options are Enabled and **Disabled**.

CPU C7 Report

Select Enabled to allow the BIOS to report the CPU C7 State (ACPI C3) to the operating system. CPU C7 State is a processor-specific low C-State. The options are Enabled and **Disabled**.

Package C-State limit

This feature allows the user to set the limit on the C-State package register. The options are **C0**, C2, C6, and No Limit.

Factory Long Duration Power Limit

This item displays the power limit set by the manufacturer during which long duration power is maintained.

Long Duration Power Limit

This item displays the power limit set by the manufacturer during which long duration power is maintained.

Factory Long Duration Maintained

This item displays the period of time set by the manufacturer during which long duration power is maintained.

Recommended Short Duration Power

This item displays the short duration power settings recommended by the manufacturer.

Short Duration Power Limit

This item displays the time period during which short duration power is maintained.

► Chipset Configuration**► North Bridge Configuration**

This feature allows the user to configure the settings for the Intel North Bridge.

► Intergrated IO Configuration**Intel VT-d**

Select Enabled to enable Intel Virtualization Technology support for Direct I/O VT-d by reporting the I/O device assignments to the VMM (Virtual Working Memory) through the DMAR ACPI Tables. This feature offers fully-protected I/O resource sharing across Intel platforms, providing greater reliability, security and availability in networking and data-sharing. The options are **Enabled** and Disabled.

Intel I/OAT

The Intel I/OAT (I/O Acceleration Technology) significantly reduces CPU overhead by leveraging CPU architectural improvements, freeing the system resource for other tasks. The options are Disabled and **Enabled**.

DCA Support

Select Enabled to use Intel's DCA (Direct Cache Access) Technology to improve data transfer efficiency. The options are **Enabled** and Disabled.

IIO 0 PCIe Port Bifurcation Control/IIO 1 PCIe Port Bifurcation Control

This submenu allows the user to configure the following IO PCIe Port Bifurcation Control settings for IIO 0 PCIe port and IIO 1 PCIe port, which determine how to distribute the available PCI-Express lanes to the PCI-Exp. Root Ports.

IOU1-PCIe Port

This feature allows the user to set the PCI-Exp bus speed between IOU1 and PCIe port. The options are **x4x4** and x8.

Port 1A Link Speed

Select GEN1 to enable PCI-Exp Generation 1 support for Port 1A. Select GEN2 to enable PCI-Exp Generation 2 support for Port 1A. Select GEN3 to enable PCI-Exp Generation 3 support for Port 1A. The options are GEN1, **GEN2**, and GEN3.

Port 1B Link Speed

Select GEN1 to enable PCI-Exp Generation 1 support for Port 1B. Select GEN2 to enable PCI-Exp Generation 2 support for Port 1B. Select GEN3 to enable PCI-Exp Generation 3 support for Port 1B. The options are GEN1, GEN2 and **GEN3**.

Dn Tx Preset

This feature allows the user to select the preset setting for a downstream component transmitter. The options are P0 (-6.0/0.0 dB), P1 (-3.5/0.0 dB), P2 (-4.5/0.0 dB), P3 (-2.5/0.0 dB), P4 (0.0/0.0 dB), P5 (0.0/-2.0 dB), P6 (0.0/-2.5 dB), **P7 (-6.0/-3.5 dB)**, P8 (-3.5/-3.5 dB), P9 (0.0/-3.5 dB), and Auto.

Dn Rx Preset

This feature allows the user to select a preset setting for a downstream component receiver. The options are **P0 (-6.0 dB)**, P1 (-7.0 dB), P2 (-8.0 dB), P3 (-9.0 dB), P4 (-10.0 dB), P5 (-11.0 dB), P6 (-12.0 dB), and Auto.

Up Tx Preset

This feature allows the user to select the preset setting for an upstream component transmitter. The options are P0 (-6.0/0.0 dB), P1 (-3.5/0.0 dB), P2 (-4.5/0.0 dB), P3 (-2.5/0.0 dB), P4 (0.0/0.0 dB), P5 (0.0/-2.0 dB), P6 (0.0/-2.5 dB), **P7 (-6.0/-3.5 dB)**, P8 (-3.5/-3.5 dB), P9 (0.0/-3.5 dB), and Auto.

IOU2-PCIe Port

If this feature allows the user to set the bus speed between the IOU2 and the PCI-Exp port. The options are x4x4x4x4, x4x4x8, x8x4x4, **x8x8**, and x16.

Port 2A Link Speed

Select GEN1 to enable PCI-Exp Generation 1 support for Port 2A. Select GEN2 to enable PCI-Exp Generation 2 support for Port 2A. Select GEN3 to enable PCI-Exp Generation 3 support for Port 2A. The options are GEN1, GEN2, and **GEN3**.

Dn Tx Preset

This feature allows the user to select the preset setting for a downstream component transmitter. The options are P0 (-6.0/0.0 dB), P1 (-3.5/0.0 dB), P2 (-4.5/0.0 dB), P3 (-2.5/0.0 dB), P4 (0.0/0.0 dB), P5 (0.0/-2.0 dB), P6 (0.0/-2.5 dB), **P7 (-6.0/-3.5 dB)**, P8 (-3.5/-3.5 dB), P9 (0.0/-3.5 dB), and Auto.

Dn Rx Preset

This feature allows the user to select a preset setting for a downstream component receiver. The options are **P0 (-6.0 dB)**, P1 (-7.0 dB), P2 (-8.0 dB), P3 (-9.0 dB), P4 (-10.0 dB), P5 (-11.0 dB), P6 (-12.0 dB), and Auto.

Up Tx Preset

This feature allows the user to select the preset setting for an upstream component transmitter. The options are P0 (-6.0/0.0 dB), P1 (-3.5/0.0 dB), P2 (-4.5/0.0 dB), P3 (-2.5/0.0 dB), P4 (0.0/0.0 dB), P5 (0.0/-2.0 dB), P6 (0.0/-2.5 dB), **P7 (-6.0/-3.5 dB)**, P8 (-3.5/-3.5 dB), P9 (0.0/-3.5 dB), and Auto.

IOU3-PCIe Port

If this feature allows the user to set the bus speed between the IOU2 and the PCI-Exp port. The options are x4x4x4x4, x4x4x8, x8x4x4, **x8x8**, and x16.

Port 3A Link Speed

Select GEN1 to enable PCI-Exp Generation 1 support for Port 3A. Select GEN2 to enable PCI-Exp Generation 2 support for Port 3A. Select GEN3 to enable PCI-Exp Generation 3 support for Port 3A. The options are GEN1, GEN2, and **GEN3**.

Dn Tx Preset

This feature allows the user to select the preset setting for a downstream component transmitter. The options are P0 (-6.0/0.0 dB), P1 (-3.5/0.0 dB), P2 (-4.5/0.0 dB), P3 (-2.5/0.0 dB), P4 (0.0/0.0 dB), P5 (0.0/-2.0 dB), P6 (0.0/-2.5 dB), **P7 (-6.0/-3.5 dB)**, P8 (-3.5/-3.5 dB), P9 (0.0/-3.5 dB), and Auto.

Dn Rx Preset

This feature allows the user to select a preset setting for a downstream component receiver. The options are **P0 (-6.0 dB)**, P1 (-7.0 dB), P2 (-8.0 dB), P3 (-9.0 dB), P4 (-10.0 dB), P5 (-11.0 dB), P6 (-12.0 dB), and Auto.

Up Tx Preset

This feature allows the user to select the preset setting for an upstream component transmitter. The options are P0 (-6.0/0.0 dB), P1 (-3.5/0.0 dB), P2 (-4.5/0.0 dB), P3 (-2.5/0.0 dB), P4 (0.0/0.0 dB), P5 (0.0/-2.0 dB), P6 (0.0/-2.5 dB), **P7 (-6.0/-3.5 dB)**, P8 (-3.5/-3.5 dB), P9 (0.0/-3.5 dB), and Auto.

► QPI Configuration**Current QPI Link**

This item displays the current status of the QPI Link.

Current QPI Frequency

This item displays the frequency of the QPI Link.

Isoc

Select Enabled to enable Isynchronous support to meet QoS (Quality of Service) requirements. This feature is especially important for virtualization technology. The options are **Disabled** and Enabled.

QPI (Quick Path Interconnect) Link Speed Mode

Use this feature to select data transfer speed for QPI Link connections. The options are **Fast** and Slow.

QPI Link Frequency Select

Use this feature to select the desired QPI frequency. The options are **Auto**, 6.4 GT/s, 7.2 GT/s, and 8.0 GT/s.

QPI Link0s

This feature allows the user to set the QPI power state to a lower setting for QPI Link0s. The options are **Disabled** and Enabled.

QPI Link0p

This feature allows the user to set the QPI power state to a lower setting for QPI Link0p. The options are **Disabled** and Enabled.

►DIMM Configuration**Current Memory Mode**

This item displays the current memory mode.

Current Memory Speed

This item displays the current memory speed.

Mirroring

This item displays if memory mirroring is supported by the motherboard.

Sparing

This item displays if memory sparing can be supported by the motherboard.

►DIMM Information**CPU Socket 0 DIMM Information/CPU Socket 1 DIMM Information****P1/P2-DIMMA1~3, P1/P2-DIMMB1~3, P1/P2-DIMMC1~3, P1/P2-DIMMD1~3**

The status of the memory modules specified above will be displayed as detected by the BIOS.

Memory Mode

When Independent is selected, all DIMMs are available to the operating system. When Mirroring is selected, the motherboard maintains two identical copies of all data in memory for data backup. When Lockstep is selected, the motherboard uses two areas of memory to run the same set of operations in parallel. The options are **Independent**, Mirroring, and Lockstep.

DDR Speed

Use this feature to force a DDR3 memory module to run at a frequency other than what the system is specified in the specification. The options are **Auto**, Force DDR3-800, Force DDR3-1066, Force DDR3-1333, Force DDR3-1600 and Force SPD.

Channel Interleaving

This feature selects from the different channel interleaving methods. The options are **Auto**, 1 Way, 2 Way, 3, Way, and 4 Way.

Rank Interleaving

This feature allows the user to select a rank memory interleaving method. The options are **Auto**, 1 Way, 2 Way, 4, Way, and 8 Way.

Patrol Scrub

Patrol Scrubbing is a process that allows the CPU to correct correctable memory errors detected on a memory module and send the correction to the requestor (the original source). When this item is set to Enabled, the IO hub will read and write back one cache line every 16K cycles, if there is no delay caused by internal processing. By using this method, roughly 64 GB of memory behind the IO hub will be scrubbed every day. The options are **Enabled** and Disabled.

Demand Scrub

Demand Scrubbing is a process that allows the CPU to correct correctable memory errors found on a memory module. When the CPU or I/O issues a demand-read command, and the read data from memory turns out to be a correctable error, the error is corrected and sent to the requestor (the original source). Memory is updated as well. Select Enabled to use Demand Scrubbing for ECC memory correction. The options are Enabled and **Disabled**.

Data Scrambling

Select Enabled to enable data scrubbing and ensure data security and integrity. The options are **Disabled** and Enabled.

DRAM RAPL

This item allows the user to select the average power limit setting when a DRAM module is in operation. The options are Disabled, Mode 0, and **Mode 1**.

Device Tagging

Select Enabled to support device tagging. The options are **Disabled** and Enabled.

Rank Margin

Select Enabled to set the memory rank margin setting. The options are **Disabled** and Enabled.

Thermal THrottling

Throttling improves reliability and reduces power consumption in the processor via automatic voltage control during processor idle states. The options are Disabled and **CLTT** (Closed Loop Thermal Throttling).

Serial Message Debug Level

This feature allows the user to select the serial message debug level. The options are **Minimum**, Maximum, Trace, and Memory Training.

► South Bridge Configuration

This feature allows the user to configure the settings for the Intel PCH chip.

PCH Information

This feature displays the following PCH information.

Name: This item displays the name of the PCH chip.

Stepping: This item displays the status of the PCH stepping.

USB Devices: This item displays the USB devices detected by the BIOS.

All USB Devices

This feature enables all USB ports/devices. The options are Disabled and **Enabled**. (If set to Enabled, EHCI Controller 1 and Controller 2 will appear.)

EHCI Controller 1/EHCI Controller 2 (Available when All USB Devices is set to Enabled)

Select Enabled to enable Enhanced Host Controller Interface (EHCI) Controller 1/ Controller 2. The options are Disabled and **Enabled**.

Legacy USB Support (Available when USB Functions is not Disabled)

Select Enabled to support legacy USB devices. Select Auto to disable legacy support if USB devices are not present. Select Disable to have USB devices available for EFI (Extensive Firmware Interface) applications only. The settings are Disabled, **Enabled** and Auto.

Port 60/64 Emulation

Select Enabled to enable I/O port 60h/64h emulation support for the legacy USB keyboard so that it can be fully supported by the operating systems that does not recognize a USB device. The options are Disabled and **Enabled**.

EHCI Hand-Off

This item is for operating systems that do not support Enhanced Host Controller Interface (EHCI) hand-off. When enabled, EHCI ownership change will be claimed by the EHCI driver. The options are **Disabled** and Enabled.

► SATA Configuration

When this submenu is selected, the AMI BIOS automatically detects the presence of IDE or SATA devices and displays the following items.

SATA Port0~SATA Port5: The AMI BIOS displays the status of each SATA port as detected by the BIOS.

SATA Mode

Use this feature to configure SATA mode for a selected SATA port. The options are Disabled, IDE Mode, **AHCI Mode** and RAID Mode. The following are displayed depending on your selection:

IDE Mode

The following items are displayed when IDE Mode is selected:

Serial-ATA (SATA) Controller 0~1

Use this feature to activate or deactivate the SATA controller, and set the compatibility mode. The options for Controller 0 are Enhanced and **Compatible**. The default of SATA Controller 1 is **Enhanced**.

AHCI Mode

The following items are displayed when the AHCI Mode is selected.

Aggressive Link Power Management

Select Enabled to enable Aggressive Link Power Management support for Cougar Point B0 stepping and beyond. The options are **Enabled** and Disabled.

Port 0~5 Hot Plug

Select Enabled to enable hot-plug support for a particular port, which will allow the user to change a hardware component or device without shutting down the system. The options are Enabled and **Disabled**.

Staggered Spin Up

Select Enabled to enable Staggered Spin-up support to prevent excessive power consumption caused by multiple HDDs spinning-up simultaneously. The options are Enabled and **Disabled**.

RAID Mode

The following items are displayed when RAID Mode is selected:

PCH RAID CodeBase

Select Intel or LSI to specify the code base to be used for RAID support. The options are **Intel** and LSI.

Port 0~5 Hot Plug

Select Enabled to enable hot-plug support for the particular port. The options are Enabled and **Disabled**.

► SAS Configuration**OnChip SAS Oprom**

Select Enabled to support the onboard SAS Option ROM to boot up the system via a storage device. The options are Disabled and **Enabled**.

SAS Option ROM Codebase

Select Intel to use the Intel SAS controller to support onboard SAS Option ROM. Select LSI to use the LSI SAS controller to support onboard SAS Option ROM. The options are **Intel** and LSI.

Device0~Device7: The AMI BIOS will automatically detect the onboard SAS devices and display the status of each SAS device as detected.

► Thermal Configuration**Thermal Management**

Select Enabled to initialize the PCH Thermal subsystem device located at D31:F6. The options are **Enabled** and Disabled.

ME SMBus Thermal Reporting

Select Enabled to support ME SMBus (System Management Bus) reporting. The options are **Enabled** and Disabled.

PCH Temp Read

Select Enabled to allow the BIOS to read the PCH temperature. The options are **Enabled** and Disabled.

CPU Energy Read

Select Enabled to allow the BIOS to read the CPU energy status. The options are **Enabled** and Disabled.

CPU Temp Read

Select Enabled to allow the BIOS to read the CPU temperature. The options are **Enabled** and Disabled.

Alert Enable Lock

Select Enabled to lock all alert-enabling settings. The options are Enabled and **Disabled**.

► PCIe/PCI/PnP Configuration**PCI ROM Priority**

Use this feature to select the Option ROM to boot the system when there are multiple Option ROMs available in the system. The options are EFI Compatible ROM and **Legacy ROM**.

PCI Latency Timer

Use this feature to set the latency Timer of each PCI device installed on a PCI bus. Select 64 to set the PCI latency to 64 PCI clock cycles. The options are 32, **64**, 96, 128, 160, 192, 224 and 248.

Above 4G Decoding (Available if the system supports 64-bit PCI decoding)

Select Enabled to decode a PCI device that supports 64-bit in the space above 4G Address. The options are Enabled and **Disabled**.

PERR# Generation

Select Enabled to allow a PCI device to generate a PERR number for a PCI Bus Signal Error Event. The options are Enabled and **Disabled**.

SERR# Generation

Select Enabled to allow a PCI device to generate an SERR number for a PCI Bus Signal Error Event. The options are **Enabled** and Disabled.

Maximum Payload

Select Auto to allow the system BIOS to automatically set the maximum payload value for a PCI-E device to enhance system performance. The options are **Auto**, 128 Bytes, 256 Bytes, 512 Bytes, 1024 Bytes, 2048 Bytes, and 4096 Bytes.

Maximum Read Request

Select Auto to allow the system BIOS to automatically set the maximum Read Request size for a PCI-E device to enhance system performance. The options are Auto, 128 Bytes, 256 Bytes, 512 Bytes, 1024 Bytes, 2048 Bytes, and 4096 Bytes.

ASPM Support

This feature allows the user to set the Active State Power Management (ASPM) level for a PCI-E device. Select Force L0 to force all PCI-E links to operate at L0 state. Select Auto to allow the system BIOS to automatically set the ASPM level for the system. Select Disabled to disable ASPM support. The options are **Disabled**, Force L0, and Auto.

 **Warning:** Enabling ASPM support may cause some PCI-E devices to fail!

CPU1 Slot 1 PCI-E 3.0 x16 OPROM/CPU1 Slot 2 PCI-E 3.0 x4 OPROM/CPU1 Slot 3 PCI-E 3.0 x16 OPROM/CPU2 Slot 1 PCI-E 3.0 x16 OPROM/CPU2 Slot 2 PCI-E 3.0 x16 OPROM/CPU1 Slot 1 PCI-E 3.0 x8 OPROM

Select Enabled to enable Option ROM support to boot the computer using a network interface from the slots specified above. The options are **Enabled** and Disabled.

Onboard LAN Option ROM Select

Select iSCSI to use the iSCSI Option ROM to boot the computer using a network device. Select PXE (Preboot Execution Environment) to use an PXE Option ROM to boot the computer using a network device. The options are iSCSI and **PXE**.

Load Onboard LAN1 Option ROM/Load Onboard LAN2 Option ROM/ Load Onboard LAN3 Option ROM/Load Onboard LAN4 Option ROM

Select Enabled to enable the onboard LAN1 Option ROM~LAN4 Option ROM. This is to boot the computer using a network device. The default setting for LAN1

Option ROM is **Enabled**, and the default settings for LAN2 Option ROM~LAN4 Option ROM are **Disabled**.

VGA Priority

This feature allows the user to select the graphics adapter to be used as the primary boot device. The options are **Onboard VGA**, and Add-on VGA.

Network Stack

Select Enabled enable PXE (Preboot Execution Environment) or UEFI (Unified Extensible Firmware Interface) for network stack support. The options are Enabled and **Disabled**.

► Serial Port 1 Configuration/Serial Port 2 Configuration**Serial Port**

Select Enabled to enable a serial port specified by the user. The options are **Enabled** and Disabled.

Device Settings

This feature indicated if reset is required or not for a serial port specified.

Change Settings

Use this feature to set the optimal Environment_Control_Interface (PECI) setting for a serial port specified. The default setting is **Auto**, which will allow the AMI BIOS to automatically select the best setting for the PECI platform.

Device Mode

Use this feature to select the desired mode for a serial port specified. The options are **Normal** and High Speed.

► Serial Port Console Redirection

- **COM 0/COM1**

These two submenus allow the user to configure the following Console Redirection settings for a COM Port specified by the user.

Console Redirection

Select Enabled to use a COM Port selected by the user for Console Redirection. The options are **Enabled** and Disabled.

► Console Redirection Settings

This feature allows the user to specify how the host computer will exchange data with the client computer, which is the remote computer used by the user.

Terminal Type

This feature allows the user to select the target terminal emulation type for Console Redirection. Select VT100 to use the ASCII Character set. Select VT100+ to add color and function key support. Select ANSI to use the Extended ASCII Character Set. Select VT-UTF8 to use UTF8 encoding to map Unicode characters into one or more bytes. The options are **ANSI**, VT100, VT100+, and VT-UTF8.

Bits Per second

Use this feature to set the transmission speed for a serial port used in Console Redirection. Make sure that the same speed is used in the host computer and the client computer. A lower transmission speed may be required for long and busy lines. The options are 9600, 19200, 57600 and **115200** (bits per second).

Data Bits

Use this feature to set the data transmission size for Console Redirection. The options are 7 Bits and **8 Bits**.

Parity

A parity bit can be sent along with regular data bits to detect data transmission errors. Select Even if the parity bit is set to 0, and the number of 1's in data bits is even. Select Odd if the parity bit is set to 0, and the number of 1's in data bits is odd. Select None if you do not want to send a parity bit with your data bits in transmission. Select Mark to add a mark as a parity bit to be sent along with the data bits. Select Space to add a Space as a parity bit to be sent with your data bits. The options are **None**, Even, Odd, Mark and Space.

Stop Bits

A stop bit indicates the end of a serial data packet. Select 1 Stop Bit for standard serial data communication. Select 2 Stop Bits if slower devices are used. The options are **1** and 2.

Flow Control

This feature allows the user to set the flow control for Console Redirection to prevent data loss caused by buffer overflow. Send a "Stop" signal to stop sending data when the receiving buffer is full. Send a "Start" signal to start sending data when the receiving buffer is empty. The options are **None**, Hardware RTS/CTS, and Software Xon/Xoff.

VT-UTF8 Combo Key Support

Select Enabled to enable VT-UTF8 Combination Key support for ANSI/VT100 terminals. The options are **Enabled** and Disabled.

Recorder Mode

Select Enabled to capture the data displayed on a terminal and send it as text messages to a remote server. The options are **Disabled** and Enabled.

Resolution 100x31

Select Enabled for extended-terminal resolution support. The options are **Disabled** and Enabled.

Legacy OS Redirection

Use this feature to select the number of rows and columns used in Console Redirection for legacy OS support. The options are **80x24** and 80x25.

Serial Port for Out-of-Band Management/Windows Emergency Management Services (EMS)

The submenu allows the user to configure the following Console Redirection settings to support Out-of-Band Serial Port management.

► ACPI Configuration

Use this feature to configure Advanced Configuration and Power Interface (ACPI) power management settings for your system.

High Precision Event Timer

Select Enabled to activate the High Precision Event Timer (HPET) that produces periodic interrupts at a much higher frequency than a Real-time Clock (RTC) does in synchronizing multimedia streams, providing smooth playback, reducing the dependency on other timestamp calculation devices, such as an x86 RDTSC Instruction embedded in the CPU. The High Performance Event Timer is used to replace the 8254 Programmable Interval Timer. The options are **Enabled** and Disabled.

► Trusted Computing (Available when a TPM device is detected by the BIOS)

Configuration

TPM Support

Select Enabled on this item and enable the TPM jumper on the motherboard to enable TPM support to improve data integrity and network security. The options are **Enabled** and Disabled.

TPM State

Select Enabled to enable TPM security settings to improve data integrity and network security. The options are **Disabled** and Enabled.

Pending Operation: This item displays the status of a pending operation.

Current Status Information: This item displays the information regarding the current TPM status.

TPM Enable Status

This item displays the status of TPM Support to indicate if TPM is currently enabled or disabled.

TPM Active Status

This item displays the status of TPM Support to indicate if TPM is currently active or deactivated.

TPM Owner Status

This item displays the status of TPM Ownership.

►Intel TXT (LT-SX) Configuration**Intel TXT (LT-SX) Hardware Support**

This feature indicates if the following hardware components support the Intel Trusted Execution Technology.

CPU: TXT (Trusted Execution Technology) Feature

Chipset: TXT (Trusted Execution Technology) Feature

Intel TXT (LT-SX) Configuration

This feature displays the following TXT configuration setting.

TXT (LT-SX) Support: This item indicated if the Intel TXT support is enabled or disabled.

Intel TXT (LT-SX) Dependencies

This feature displays the features that need to be enabled for the Intel Trusted Execution Technology to work properly in the system.

VT-d Support: Intel Virtualization Technology with Direct I/O support

VT Support: Intel Virtualization Technology support

TPM Support: Trusted Platform support

TPM State: Trusted Platform state

►Intel ME Subsystem Configuration

This feature displays the following ME Subsystem Configuration settings.

- **ME BIOS Interface Version**
- **ME Version**

iSCSI: This item displays the following iSCSI information:

iSCSI Initiation Name: This item displays the name of the iSCSI Initiator, which is a unique name used in the world.

Main Configuration Page: This item displays the information regarding the main iSCSI Configuration page.

7-4 Event Logs

Use this feature to configure Event Log settings.



►Change SMBIOS Event Log Settings

This feature allows the user to configure SMBIOS Event settings.

Enabling/Disabling Options

SMBIOS Event Log

Select Enabled to enable SMBIOS (System Management BIOS) Event Logging during system boot. The options are **Enabled** and Disabled.

Runtime Error Logging Support

Select Enabled to support Runtime Error Logging. The options are **Enabled** and Disabled.

Memory Correctable Error Threshold

This feature allows the user to enter the threshold value for correctable memory errors. The default setting is **10**.

PCI Error Logging Support

Select Enabled to support error event logging for PCI slots. The options are **Enabled** and Disabled.

Erasing Settings

Erase Event Log

Select Enabled to erase the SMBIOS (System Management BIOS) Event Log, which is completed before a event logging is initialized upon system reboot. The options are **No** and Yes.

When Log is Full

Select Erase Immediately to immediately erase SMBIOS error event logs that exceed the limit when the SMBIOS event log is full. Select Do Nothing for the system to do nothing when the SMBIOS event log is full. The options are **Do Nothing** and Erase Immediately.

SMBIOS Event Log Standard Settings

Log System Boot Event

Select Enabled to log system boot events. The options are **Disabled** and Enabled.

MECI (Multiple Event Count Increment)

Enter the increment value for the multiple event counter. Enter a number between 1 to 255. The default setting is **1**.

METW (Multiple Event Count Time Window)

This item allows the user to decide how long (in minutes) should the multiple event counter wait before generating a new event log. Enter a number between 0 to 99. The default setting is **60**.

View SMBIOS Event Log

This item allows the user to view the event in the SMBIOS event log. Select this item and press <Enter> to view the status of an event in the log.

- Date
- Time
- Error Code
- Severity

View System Event Log

This item allows the user to view the event in the system event log. Select this item and press <Enter> to view the status of an event in the log.

- Date
- Time
- Sensor
- Type

7-5 IPMI

Use this feature to configure Intelligent Platform Management Interface (IPMI) settings.



IPMI Firmware Revision

This item indicates the IPMI firmware revision used in your system.

IPMI Status

This item indicates the status of the IPMI firmware installed in your system.

► System Event Log

Enabling/Disabling Options

SEL Components

Select Enabled for all system event logging at bootup. The options are **Enabled** and Disabled.

Erasing Settings

Erase SEL

Select Yes, On next reset to erase all system event logs upon next system reboot. Select Yes, On every reset to erase all system event logs upon each system reboot. Select No to keep all system event logs after each system reboot. The options are **No**, Yes, On next reset, and Yes, On every reset.

When SEL is Full

This feature allows the user to decide what the BIOS should do when the system event log is full. Select Erase Immediately to erase all events in the log when the system event log is full. The options are **Do Nothing** and Erase Immediately.

Customize EFI Logging Options

Log EFI Status Codes

Select Enabled to log EFI (Extensible Firmware Interface) Status Codes, Error Codes or Progress Codes. The options are **Enabled** and Disabled.

 **Note:** After making changes on a setting, be sure to reboot the system for the changes to take effect.

► BMC Network Configuration

LAN Channel 1: This feature allows the user to configure the settings for LAN1 Port.

Update IPMI LAN Configuration

This feature allows the user to decide if the BIOS should configure the IPMI setting at next system boot. The options are **No** and Yes. If the option is set to Yes, the user is allow to configure the IPMI settings at next system boot:

Configuration Address Source

This feature allows the user to select the source of the IP address for this computer. If Static is selected, you will need to know the IP address of this computer and enter it to the system manually in the field. If DHCP is selected, the BIOS will search for a DHCP (Dynamic Host Configuration Protocol) server in the network that is attached to and request the next available IP address for this computer. The options are **DHCP** and Static. The following items are assigned IP addresses automatically if DHCP is selected.

Station IP Address

This item displays the Station IP address for this computer. This should be in decimal and in dotted quad form (i.e., 192.168.10.253).

Subnet Mask

This item displays the sub-network that this computer belongs to. The value of each three-digit number separated by dots should not exceed 255.

Station Mac Address

This item displays the Station Mac address for this computer. Mac addresses are 6 two-digit hexadecimal numbers.

7-6 Boot

This submenu allows the user to configure the following boot settings for the system.



Boot Option Priorities

Boot Option #1

This item allows the user to select the first boot drive. Select a LAN device to boot the system from the network connection. Select UEFI to boot the system from the UEFI: Built-in EFI Shell. The options are **LAN Device**, UEFI: Built-in EFI Shell, and Disabled.

Boot Option #2

This item allows the user to select the first boot device. Select a LAN device to boot the system from the network connection. Select UEFI to boot the system from the UEFI: Built-in EFI Shell. The options are LAN Device, **UEFI: Built-in EFI Shell**, and Disabled.

Network Devices

► Delete Boot Options

Delete Boot Option

This item allows the user to select a boot device to delete from the boot priority list. Select UEFI: Built-in EFI Shell to delete it from the boot priority list which will prevent system boot from the UEFI Shell. The options are Select One to Delete and **UEFI: Built-in EFI Shell**.

7-7 Security

This menu allows the user to configure the following security settings for the system.



Administrator Password

Use this feature to set the Administrator Password which is required to enter the BIOS setup utility. The length of the password should be from 3-character long to 8-character long.

User Password

Use this feature to set a User Password which is required to log into the system and to enter the BIOS setup utility. The length of the password should be from 3-character long to 8-character long.

7-8 Save & Exit

This submenu allows the user to configure the Save and Exit settings for the system.



Discard Changes and Exit

Select this option to quit the BIOS Setup without making any permanent changes to the system configuration, and reboot the computer. Select Discard Changes and Exit, and press <Enter>. When the dialog box appears, asking you if you want to exit the BIOS setup without saving, click **Yes** to quit BIOS without saving the changes, or click No to quit the BIOS and save changes.

Save Changes and Reset

When you have completed the system configuration changes, select this option to save the changes and reboot the computer so that the new system configuration settings can take effect. Select Save Changes and Exit, and press <Enter>. When the dialog box appears, asking you if you want to exit the BIOS setup without saving, click **Yes** to quit BIOS without saving the changes, or click No to quit the BIOS and save changes.

Save Options

Save Changes

Select this option and press <Enter> to save all changes you've done so far and return to the AMI BIOS utility Program. When the dialog box appears, asking you if you want to save configuration, click **Yes** to save the changes, or click No to return to the BIOS without making changes.

Discard Changes

Select this feature and press <Enter> to discard all the changes and return to the BIOS setup. When the dialog box appears, asking you if you want to load previous values, click **Yes** to load the values previous saved, or click No to keep the changes you've made so far.

Restore Optimized Defaults

Select this feature and press <Enter> to load the optimized default settings that help optimize system performance. When the dialog box appears, asking you if you want to load optimized defaults, click **Yes** to load the optimized default settings, or click No to abandon optimized defaults.

Save as User Defaults

Select this feature and press <Enter> to save the current settings as the user's defaults. When the dialog box appears, asking you if you want to save values as user's defaults, click **Yes** to save the current values as user's default settings, or click No to keep the defaults previously saved as the user's defaults.

Restore User Defaults

Select this feature and press <Enter> to load the user's defaults previously saved in the system. When the dialog box appears, asking you if you want to restore user's defaults, click **Yes** to restore the user's defaults previously saved in the system, or click No to abandon the user's defaults that were previously saved.

Boot Override

This feature allows the user to enter a new setting to overwrite the original setting that was saved for the following devices:

- LAN Device
- UEFI: Built-in EFI Shell

Notes

Appendix A

BIOS Error Beep Codes

During the POST (Power-On Self-Test) routines, which are performed at each system boot, errors may occur.

Non-fatal errors are those which, in most cases, allow the system to continue to boot. The error messages normally appear on the screen.

Fatal errors will not allow the system to continue with bootup procedure. If a fatal error occurs, you should consult with your system manufacturer for possible repairs.

These fatal errors are usually communicated through a series of audible beeps. The numbers on the fatal error list correspond to the number of beeps for the corresponding error.

| BIOS Error Beep Codes | | |
|------------------------------|---------------------------------|--|
| Beep Code/LED | Error Message | Description |
| 1 beep | Refresh | Circuits have been reset. (Ready to power up) |
| 5 short beeps + 1 long beep | Memory error | No memory detected in the system |
| 5 long beeps + 2 short beeps | Display memory read/write error | Video adapter missing or with faulty memory |
| 1 continuous beep | System overheat | System overheat |

Notes

Appendix B

System Specifications

Processors

Single or dual Intel® Xeon E5-2600 Series processors

Note: Please refer to our web site for a complete listing of supported processors.

Chipset

Intel C600 chipset

BIOS

32 Mb AMI® SPI Flash ROM

Memory Capacity

Twenty-four DIMM sockets supporting up to 1.5 TB of LRDIMM (Load Reduced DIMM), 768 GB of RDIMM (Registered DIMMs) or 128 GB of UDIMM (Unbuffered DIMMs) ECC/Non-ECC DDR3-1866/1600/1333/1066/800 SDRAM

Note: see Section 5-5 for details.

Drive Bays

Twelve hot-swap drive bays to house SATA or SAS hard drives

Peripheral Drive Bays

One slim DVD-ROM drive

Expansion Slots

Four PCI-E 3.0 x16 slots, one PCI-E 3.0 x8 slot and one PCI-E 3.0 x4 (in a x8) slot

Serverboard

X9DRi-LN4F+ (Extended ATX form factor)

Dimensions: 13.68 x 13 in (347 x 330 mm)

Chassis

SC826BE1C-R920LPB (2U rackmount)

Dimensions: (WxHxD) 17.2 x 3.5 x 25.5 in. (37 x 89 x 648 mm)

Weight

Gross Weight: 52 lbs. (23.6 kg.)

System Cooling

Three 8-cm system cooling fans

System Input Requirements

AC Input Voltage: 100 - 240V AC auto-range

Rated Input Current: 10.7 - 4.2A max

Power Supply

Rated Output Power: 920W (Part# PWS-920P-1R)

Rated Output Voltages: +12V (75A), +5Vsb (4A)

Operating Environment

Operating Temperature: 10° to 35° C (50° to 95° F)

Non-operating Temperature: -40° to 60° C (-40° to 140° F)

Operating Relative Humidity: 8% to 90% (non-condensing)

Non-operating Relative Humidity: 5% to 95% (non-condensing)

Regulatory Compliance

Electromagnetic Emissions: FCC Class A, EN 55022 Class A, EN 61000-3-2/-3-3, CISPR 22 Class A

Electromagnetic Immunity: EN 55024/CISPR 24, (EN 61000-4-2, EN 61000-4-3, EN 61000-4-4, EN 61000-4-5, EN 61000-4-6, EN 61000-4-8, EN 61000-4-11)

Safety: CSA/EN/IEC/UL 60950-1 Compliant, UL or CSA Listed (USA and Canada), CE Marking (Europe)

California Best Management Practices Regulations for Perchlorate Materials:
This Perchlorate warning applies only to products containing CR (Manganese

Notes

(continued from front)

The products sold by Supermicro are not intended for and will not be used in life support systems, medical equipment, nuclear facilities or systems, aircraft, aircraft devices, aircraft/emergency communication devices or other critical systems whose failure to perform be reasonably expected to result in significant injury or loss of life or catastrophic property damage. Accordingly, Supermicro disclaims any and all liability, and should buyer use or sell such products for use in such ultra-hazardous applications, it does so entirely at its own risk. Furthermore, buyer agrees to fully indemnify, defend and hold Supermicro harmless for and against any and all claims, demands, actions, litigation, and proceedings of any kind arising out of or related to such ultra-hazardous use or sale.