

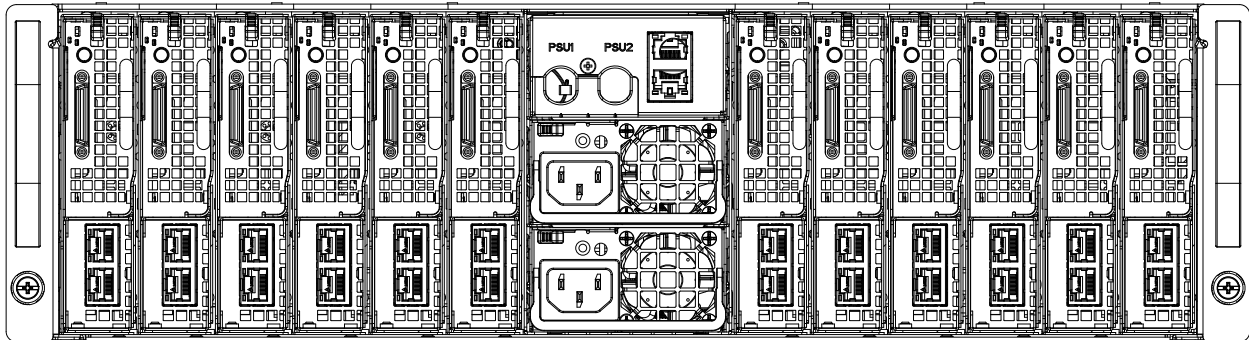

# SuperServer<sup>®</sup> 5039MC-H12TRF



USER'S MANUAL

Revision 1.0a

The information in this User's Manual has been carefully reviewed and is believed to be accurate. The vendor assumes no responsibility for any inaccuracies that may be contained in this document, and makes no commitment to update or to keep current the information in this manual, or to notify any person or organization of the updates. **Please Note: For the most up-to-date version of this manual, please see our website at [www.supermicro.com](http://www.supermicro.com).**

Super Micro Computer, Inc. ("Supermicro") reserves the right to make changes to the product described in this manual at any time and without notice. This product, including software and documentation, is the property of Supermicro and/or its licensors, and is supplied only under a license. Any use or reproduction of this product is not allowed, except as expressly permitted by the terms of said license.

IN NO EVENT WILL Super Micro Computer, Inc. BE LIABLE FOR DIRECT, INDIRECT, SPECIAL, INCIDENTAL, SPECULATIVE OR CONSEQUENTIAL DAMAGES ARISING FROM THE USE OR INABILITY TO USE THIS PRODUCT OR DOCUMENTATION, EVEN IF ADVISED OF THE POSSIBILITY OF SUCH DAMAGES. IN PARTICULAR, SUPER MICRO COMPUTER, INC. SHALL NOT HAVE LIABILITY FOR ANY HARDWARE, SOFTWARE, OR DATA STORED OR USED WITH THE PRODUCT, INCLUDING THE COSTS OF REPAIRING, REPLACING, INTEGRATING, INSTALLING OR RECOVERING SUCH HARDWARE, SOFTWARE, OR DATA.

Any disputes arising between manufacturer and customer shall be governed by the laws of Santa Clara County in the State of California, USA. The State of California, County of Santa Clara shall be the exclusive venue for the resolution of any such disputes. Supermicro's total liability for all claims will not exceed the price paid for the hardware product.

FCC Statement: This equipment has been tested and found to comply with the limits for a Class A digital device pursuant to Part 15 of the FCC Rules. These limits are designed to provide reasonable protection against harmful interference when the equipment is operated in a commercial environment. This equipment generates, uses, and can radiate radio frequency energy and, if not installed and used in accordance with the manufacturer's instruction manual, may cause harmful interference with radio communications. Operation of this equipment in a residential area is likely to cause harmful interference, in which case you will be required to correct the interference at your own expense.

California Best Management Practices Regulations for Perchlorate Materials: This Perchlorate warning applies only to products containing CR (Manganese Dioxide) Lithium coin cells. "Perchlorate Material-special handling may apply. See [www.dtsc.ca.gov/hazardouswaste/perchlorate](http://www.dtsc.ca.gov/hazardouswaste/perchlorate)".



**WARNING:** This product can expose you to chemicals including lead, known to the State of California to cause cancer and birth defects or other reproductive harm. For more information, go to [www.P65Warnings.ca.gov](http://www.P65Warnings.ca.gov).

The products sold by Supermicro are not intended for and will not be used in life support systems, medical equipment, nuclear facilities or systems, aircraft, aircraft devices, aircraft/emergency communication devices or other critical systems whose failure to perform be reasonably expected to result in significant injury or loss of life or catastrophic property damage. Accordingly, Supermicro disclaims any and all liability, and should buyer use or sell such products for use in such ultra-hazardous applications, it does so entirely at its own risk. Furthermore, buyer agrees to fully indemnify, defend and hold Supermicro harmless for and against any and all claims, demands, actions, litigation, and proceedings of any kind arising out of or related to such ultra-hazardous use or sale.

Manual Revision 1.0a

Release Date: September 26, 2024

Unless you request and receive written permission from Super Micro Computer, Inc., you may not copy any part of this document. Information in this document is subject to change without notice. Other products and companies referred to herein are trademarks or registered trademarks of their respective companies or mark holders.

Copyright © 2018 by Super Micro Computer, Inc.  
All rights reserved.

**Printed in the United States of America**

# Preface

## About this Manual

This manual is written for professional system integrators and PC technicians. It provides information for the installation and use of the SuperServer Installation and maintenance should be performed by experienced technicians only.

Please refer to the server specifications page on our website for updates on supported memory, processors and operating systems (<http://www.supermicro.com>).

## Notes

For your system to work properly, please follow the links below to download all necessary drivers/utilities and the user's manual for your server.

- Supermicro product manuals: <http://www.supermicro.com/support/manuals/>
- Product drivers and utilities: <https://www.supermicro.com/wftp/driver>
- Product safety info: [http://www.supermicro.com/about/policies/safety\\_information.cfm](http://www.supermicro.com/about/policies/safety_information.cfm)

If you have any questions, please contact our support team at:  
[support@supermicro.com](mailto:support@supermicro.com)

This manual may be periodically updated without notice. Please check the Supermicro website for possible updates to the manual revision level.

## Warnings

Special attention should be given to the following symbols used in this manual.



**Warning!** Indicates important information given to prevent equipment/property damage or personal injury.



**Warning!** Indicates high voltage may be encountered when performing a procedure.

# Contents

## **Chapter 1 Introduction**

1.1 Overview.....	8
1.2 Unpacking the System .....	8
1.3 System Features .....	9
1.4 Chassis Features .....	10
Power Button/LED.....	10
Front Features.....	11
Rear Features .....	12
1.5 Motherboard Layout .....	13
Motherboard Jumpers, Connectors, and LEDs .....	14

## **Chapter 2 Installation in a Rack**

2.1 Preparing for Setup.....	16
Choosing a Setup Location.....	16
Rack Precautions .....	16
Server Precautions.....	17
Rack Mounting Considerations .....	17
Ambient Operating Temperature.....	17
Airflow .....	17
Mechanical Loading.....	17
Circuit Overloading .....	17
Reliable Ground.....	18
2-2 Installing the Rails .....	19
2.3 Installing the Server .....	20

## **Chapter 3 Maintenance and Component Installation**

3.1 Removing Power .....	22
3.2 Accessing the System.....	23
Top Cover.....	23
Removing and Installing Motherboard Nodes.....	24
Connecting to a Node .....	25
3.3 Motherboard Components.....	26
Processor and Heatsink Installation.....	26
Memory Installation .....	30
Memory Support .....	30

---

---

DIMM Module Population Configuration.....	30
DIMM Module Population Sequence.....	31
Install Procedure.....	32
Removal Procedure.....	32
Expansion Module.....	33
Motherboard Battery.....	34
3.4 Chassis Components.....	35
Hard Drives.....	35
System Cooling.....	37
Corresponding Nodes and Fans.....	37
Replacing Fans.....	38
Air Shroud.....	39
Power Supply.....	40
<b>Chapter 4 Motherboard Connections</b>	
4.1 Node Front Panel Controls.....	41
4.2 Headers and Connectors.....	41
4.3 Ports.....	42
4.4 Jumpers.....	44
4.5 LED Indicators.....	46
<b>Chapter 5 Software</b>	
5.1 Microsoft Windows OS Installation.....	47
5.2 Driver Installation.....	49
5.3 SuperDoctor® 5.....	50
5.4 IPMI.....	51
<b>Chapter 6 BIOS</b>	
6.1 Introduction.....	52
Starting the Setup Utility.....	52
6.2 Main Menu.....	53
6.3 Advanced Setup Configurations.....	54
6.4 Event Logs.....	74
6.5 IPMI.....	76
6.6 Security.....	78
6.7 Boot.....	81
6.8 Save & Exit.....	83

***Appendix A Standardized Warning Statements for AC Systems***

A.1 About Standardized Warning Statements .....85

***Appendix B UEFI BIOS Recovery Instructions***

***Appendix C System Specifications***

## Contacting Supermicro

### Headquarters

Address: Super Micro Computer, Inc.  
980 Rock Ave.  
San Jose, CA 95131 U.S.A.

Tel: +1 (408) 503-8000

Fax: +1 (408) 503-8008

Email: [marketing@supermicro.com](mailto:marketing@supermicro.com) (General Information)  
[support@supermicro.com](mailto:support@supermicro.com) (Technical Support)

Website: [www.supermicro.com](http://www.supermicro.com)

### Europe

Address: Super Micro Computer B.V.  
Het Sterrenbeeld 28, 5215 ML  
's-Hertogenbosch, The Netherlands

Tel: +31 (0) 73-6400390

Fax: +31 (0) 73-6416525

Email: [sales@supermicro.nl](mailto:sales@supermicro.nl) (General Information)  
[support@supermicro.nl](mailto:support@supermicro.nl) (Technical Support)  
[rma@supermicro.nl](mailto:rma@supermicro.nl) (Customer Support)

Website: [www.supermicro.nl](http://www.supermicro.nl)

### Asia-Pacific

Address: Super Micro Computer, Inc.  
3F, No. 150, Jian 1st Rd.  
Zhonghe Dist., New Taipei City 235  
Taiwan (R.O.C)

Tel: +886-(2) 8226-3990

Fax: +886-(2) 8226-3992

Email: [support@supermicro.com.tw](mailto:support@supermicro.com.tw)

Website: [www.supermicro.com.tw](http://www.supermicro.com.tw)

# Chapter 1

## Introduction

### 1.1 Overview

The SuperServer 5039MC-H12TRF is a MicroCloud server system in the SC939HC-R2K04BP chassis, featuring twelve separate computing nodes each containing an X11SCE-F motherboard.

In addition to the motherboards and chassis, several included parts are listed below.

<b>Main Parts List</b>		
<b>Description</b>	<b>Part Number</b>	<b>Quantity</b>
Backplane	BPN-SAS-939HS	1
Fans	FAN-0149L4	4
CPU passive heatsink	SNK-P0047PSR	1 per node
Air shroud	MCP-310-93904-0N	1 per node
MicroLP module	AOM-CGP-I2M	1 per node
Rail kit	MCP-290-41803-0N	1 set

### 1.2 Unpacking the System

Inspect the box in which the server was shipped and note if it was damaged. If any equipment appears damaged, file a damage claim with the carrier who delivered it.

## 1.3 System Features

The following table provides you with an overview of the main features of the 5039MC-H12TRF. Refer to Appendix C for additional specifications.

<b>System Features</b>
<b>Motherboard</b>
X11SCE-F
<b>Chassis</b>
SC939HC-R2K04BP
<b>CPU</b>
Intel Xeon Processor E-2100, 8th Gen. Intel Core i3, Pentium and Celeron processors <b>Note:</b> The system does not support the redundant power feature under special circumstances when the CPUs are under Turbo mode or all CPUs consume 95W or more under stress simultaneously. The thermal throttle is normal when Intel Turbo Boost Technology is active.
<b>Socket Type</b>
LGA1151
<b>Memory</b>
Up to 128GB of unbuffered ECC Very Low Profile (VLP) DIMM with speeds of up to 2666MHz in four slots
<b>Chipset</b>
Intel C246 PCH chipset
<b>Expansion Slots</b>
One MicroLP PCI-E 3.0 x8 slot, one M.2 PCI-E 3.0 x4 slot with SATA3 support (M-Key 2280/22110), and two NVMe U.2 PCI-E x4 slots via the backplane
<b>Hard Drives</b>
Internal, two 3.5" drives or four 2.5" drives (SATA3 or NVMe)
<b>Power</b>
Dual 2000 W modules, 80+ Titanium level
<b>Cooling</b>
Four 9-cm exhaust fans; one airflow shroud per node
<b>Form Factor</b>
3U rackmount
<b>Dimensions</b>
(WxHxD) 17.5 x 5.21 x 31 in. (444.5 x 132 x 787.4 mm)

## 1.4 Chassis Features

### Power Button/LED

The main power button on each of the nodes functions as both an on/off switch and as a status LED. Pressing the button will alternately power on or remove power from the node. See the table below for the LED indications.

Power Button/LED		
LED	Description	Status
Power Button/LED	Power LED	Solid Green: Power On No Illumination: Power Off
LED1	UID LED	Solid Blue: Unit Identified
LED5	Overheat (OH)/PWR Fail (.25HZ)/ Fan Fail LED (1HZ)	Solid Red: Overheat Blinking Red: PWR Fail (.25HZ) or Fan Fail (1HZ)
LED6	BMC Heartbeat	Blinking Green: BMC Normal

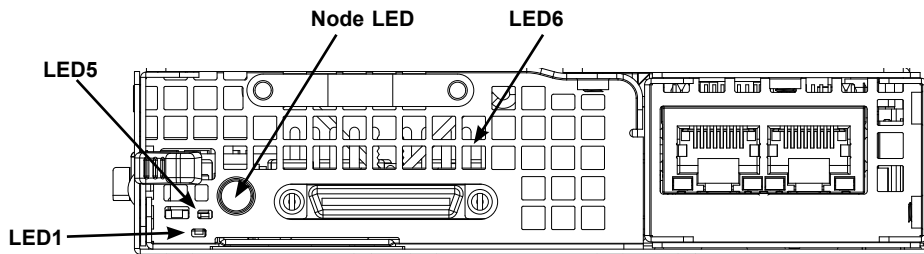

**Figure 1-1. Power Button/LED Indicator**  
(single node, front view)

## Front Features

The SC939HC-R2K04BP is a 3U chassis holding 12 discreet computing nodes. The chassis front offers access to the dual power modules. It also includes two dedicated LAN ports to provide IPMI management capabilities for all nodes.

**Note:** The IPMI connections can be used in two ways.

- Cascade: Connect one to a management device and the other to another server.
- Redundancy: For redundant IPMI management, connect each port to a different subnetwork (each to a different switch).

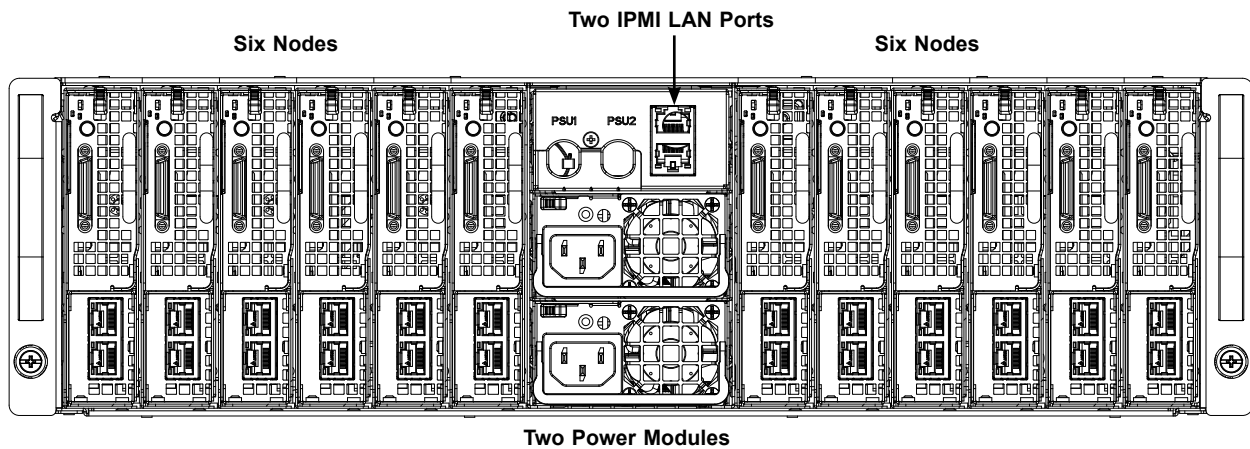

Figure 1-2. Chassis Front View

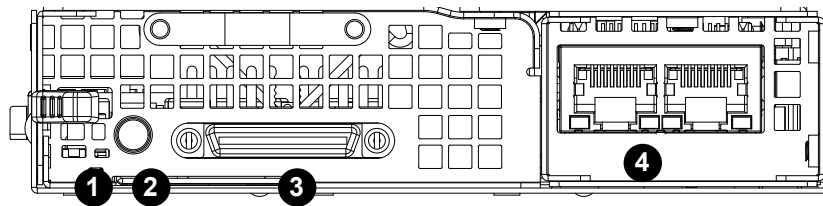
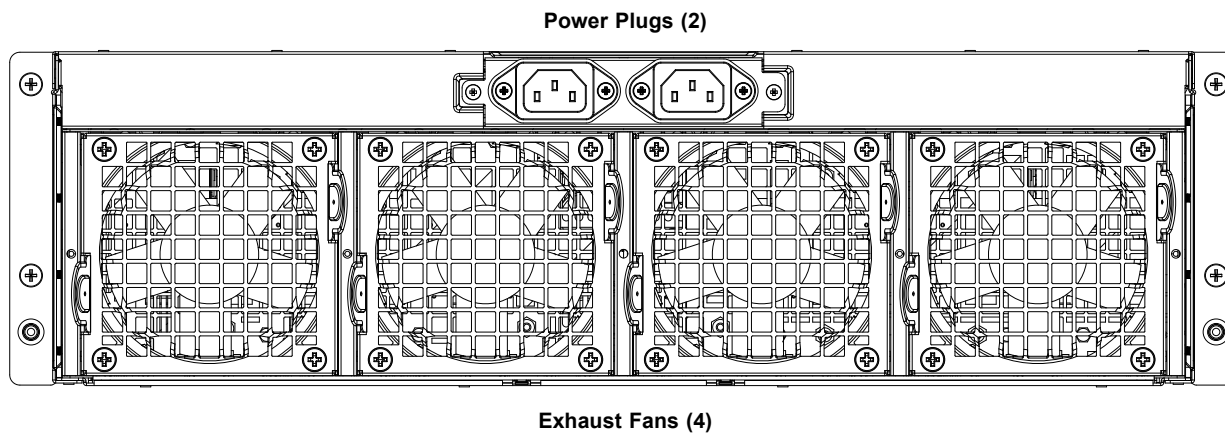

Figure 1-3. Single Node Front View

Node Features		
Item	Feature	Description
1	UID button	Unit identifier button and LED
2	Power button	Power button and LED
3	KVM port	Connect the adapter to this port to provide two USB2 ports, one COM port, and one serial port
4	LAN	Two LAN ports (provided with MicroLP expansion module) <b>Note:</b> Do not connect both dedicated IPMI ports to the same network.

## Rear Features

The illustration below shows the features included on the rear of the chassis.



**Figure 1-4. Chassis Rear View**

## 1.5 Motherboard Layout

Below is a layout of the X11SCE-F with jumper, connector, and LED locations shown. See the table on the following page for descriptions. For detailed descriptions, pinout information and jumper settings, refer to Chapter 4.

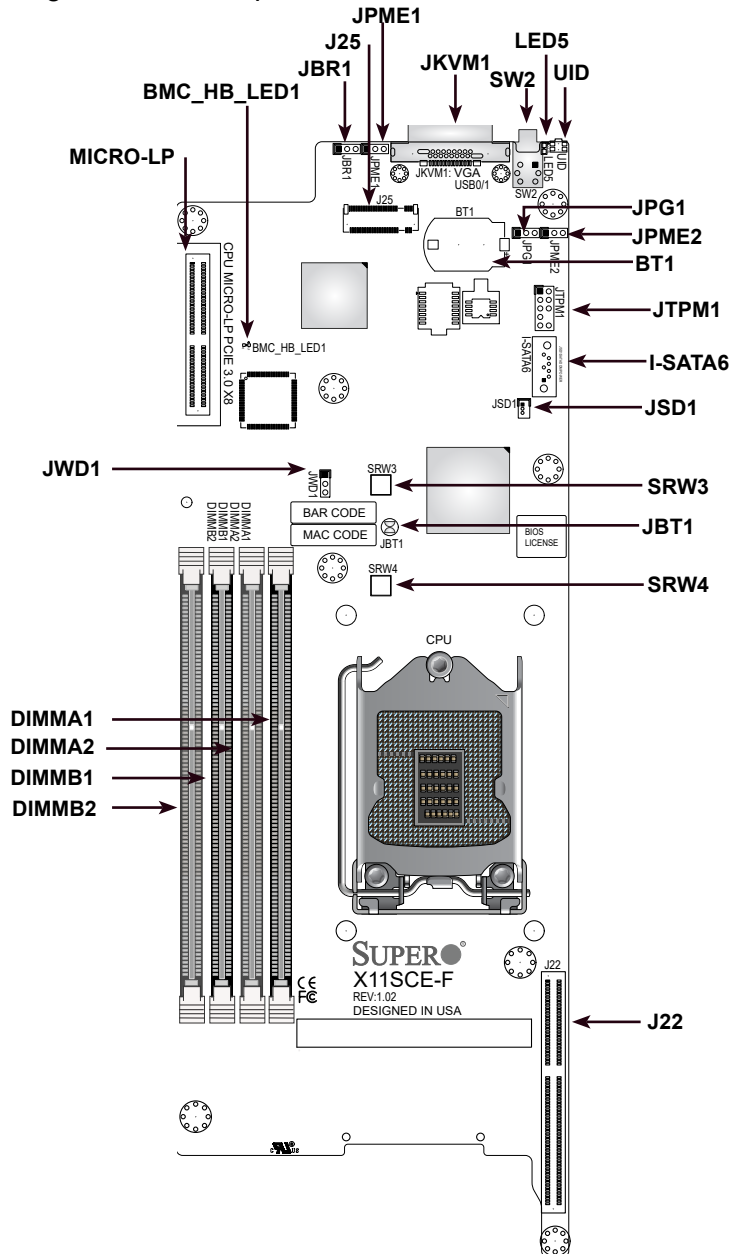

Figure 1-5. Motherboard Layout

### Notes:

- "■" indicates the location of pin 1.
- Jumpers/LED indicators not indicated are used for testing only.
- Use only the correct type of onboard CMOS battery as specified by the manufacturer. Do not install the onboard battery upside down to avoid possible explosion.

## Motherboard Jumpers, Connectors, and LEDs

Jumper	Description	Default Setting
JBT1	CMOS Clear	Open (Normal)
JPG1	VGA Enable	Pins 1-2 (Enable)
JPME1	ME Recovery	Pins 1-2 (Normal)
JPME2	Manufacturing Mode	Pins 1-2 (Normal)
JWD1	Watch Dog Timer	Pins 1-2 (Normal)

Connector	Description
BT1	Onboard CMOS battery socket
I-SATA6, I-SATA0	SATA 3.0 Ports (I-SATA6 is on the topside of the motherboard, while I-SATA0 is on the bottom) Five SATA 3.0 ports via the backplane, one SATA 3.0 port via the right angle receptor connector
J22	Connector for AOM-BPN-MC12S Backplane
J25	M.2 PCI-E 3.0 x4 slot (M-Key 2280/22110 with SATA3 support)
JKVM1	KVM Connector for VGA, 2 USB 2.0 and COM Ports
JSD1	SATA DOM Power Connector
JTPM1	Trusted Platform Module (TPM)/Port 80 connector
MICRO-LP	CPU MICRO-LP PCI-E 3.0 x8 Slot
SRW3, SRW4	M.2 Holding Screws
SW2	Power Button
UID	Unit Identifier Switch

LED	Description	Status
BMC_HB_LED1	BMC Heartbeat LED	Blinking Green: BMC normal
LED1	UID LED	Solid Blue: Unit Identified
LED5	Fan Fail/Overheat LED	Solid Red: Overheating Blinking Red: Fan Failure or Power Failure



## Chapter 2

### Installation in a Rack

This chapter provides advice and instructions for mounting your system in a rack.

#### 2.1 Preparing for Setup

The box in which the system was shipped should include the hardware needed to install it into the rack. Please note the precautions in this chapter and Appendix A.

##### Choosing a Setup Location

- The system should be situated in a clean, dust-free area that is well ventilated. Avoid areas where heat, electrical noise and electromagnetic fields are generated. It will also require a grounded AC power outlet nearby.
- Leave enough clearance in front of the rack so that you can open the front door completely (~25 inches) and approximately 30 inches of clearance in the back of the rack to allow sufficient space for airflow and access when servicing.
- This product should be installed only in a Restricted Access Location (dedicated equipment rooms, service closets, etc.).
- This product is not suitable for use with visual display workplace devices according to §2 of the German Ordinance for Work with Visual Display Units.

##### Rack Precautions

- Ensure that the leveling jacks on the bottom of the rack are extended to the floor so that the full weight of the rack rests on them.
- In single rack installations, stabilizers should be attached to the rack. In multiple rack installations, the racks should be coupled together.
- Always make sure the rack is stable before extending a server or other component from the rack.
- Extend only one server or component at a time - extending two or more simultaneously may cause the rack to become unstable.

## Server Precautions

- Review the electrical and general safety precautions in Chapter 3.
- Determine the placement of each component in the rack *before* you install the rails.
- Install the heaviest server components at the bottom of the rack first and then work your way up.
- Use a regulating uninterruptible power supply (UPS) to protect the server from power surges and voltage spikes and to keep your system operating in case of a power failure.
- Allow any drives and power supply modules to cool before touching them.
- When not servicing, always keep the front door of the rack and all covers/panels on the servers closed to maintain proper cooling.

## Rack Mounting Considerations

### ***Ambient Operating Temperature***

If installed in a closed or multi-unit rack assembly, the ambient operating temperature of the rack environment may be greater than the room's ambient temperature. Therefore, consideration should be given to installing the equipment in an environment compatible with the manufacturer's maximum rated ambient temperature ( $T_{mra}$ ).

### ***Airflow***

Equipment should be mounted into a rack so that the amount of airflow required for safe operation is not compromised.

### ***Mechanical Loading***

Equipment should be mounted into a rack so that a hazardous condition does not arise due to uneven mechanical loading.

### ***Circuit Overloading***

Consideration should be given to the connection of the equipment to the power supply circuitry and the effect that any possible overloading of circuits might have on overcurrent protection and power supply wiring. Appropriate consideration of equipment nameplate ratings should be used when addressing this concern.

### ***Reliable Ground***

A reliable ground must be maintained at all times. To ensure this, the rack itself should be grounded. Particular attention should be given to power supply connections other than the direct connections to the branch circuit (i.e. the use of power strips, etc.).



To prevent bodily injury when mounting or servicing this unit in a rack, you must take special precautions to ensure that the system remains stable. The following guidelines are provided to ensure your safety:

- This unit should be mounted at the bottom of the rack if it is the only unit in the rack.
- When mounting this unit in a partially filled rack, load the rack from the bottom to the top with the heaviest component at the bottom of the rack.
- If the rack is provided with stabilizing devices, install the stabilizers before mounting or servicing the unit in the rack.
- Slide rail mounted equipment is not to be used as a shelf or a work space.

## 2-2 Installing the Rails

Use the procedure below for installing the system to a rack.

1. Decide where you want to place the system into the rack (see "Rack Mounting Considerations" in the previous section).
2. Position the template at the front of the system to determine the locations of the screws for the chassis rails (see Figure 2-1).

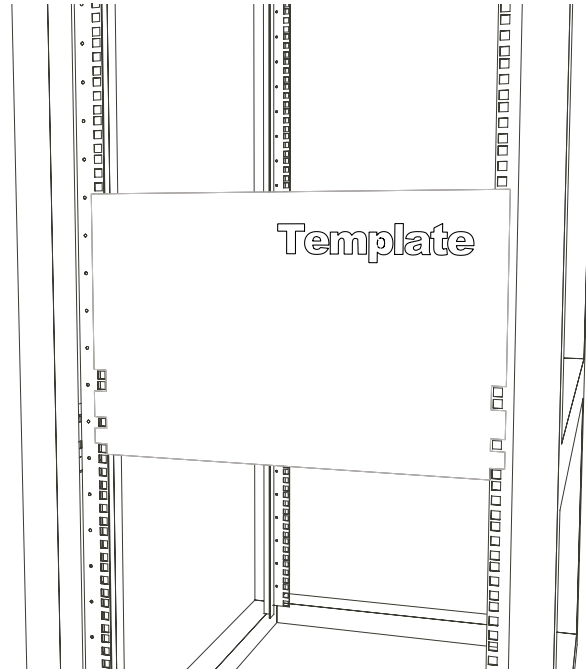

**Figure 2-1. Positioning the Template**

3. The two rail sections are screwed together to keep them immobile during shipping. Release these screws just enough to allow the rails to slide apart. Note the arrow on the rail, which indicates the end that attaches to the front of the rack.
4. Slide the rails apart far enough to match the depth of the rack. Position the rails with the template and secure the front of each to the front of the rack with two flathead screws, then secure the back of each rail to the rear of the rack with two flathead screws (see Figure 2-2). Note that the rails are left/right specific and very heavy.
5. (Optional step) Add the front left and right handles to the chassis using screws to secure each handle. Install a thumbscrew through the bottom hole of each handle.
6. With one person on either side, lift the system and slide it into the installed rails.
7. After pushing the enclosure all the way into the rack, use two round head screws on each side of the server to lock it into place.

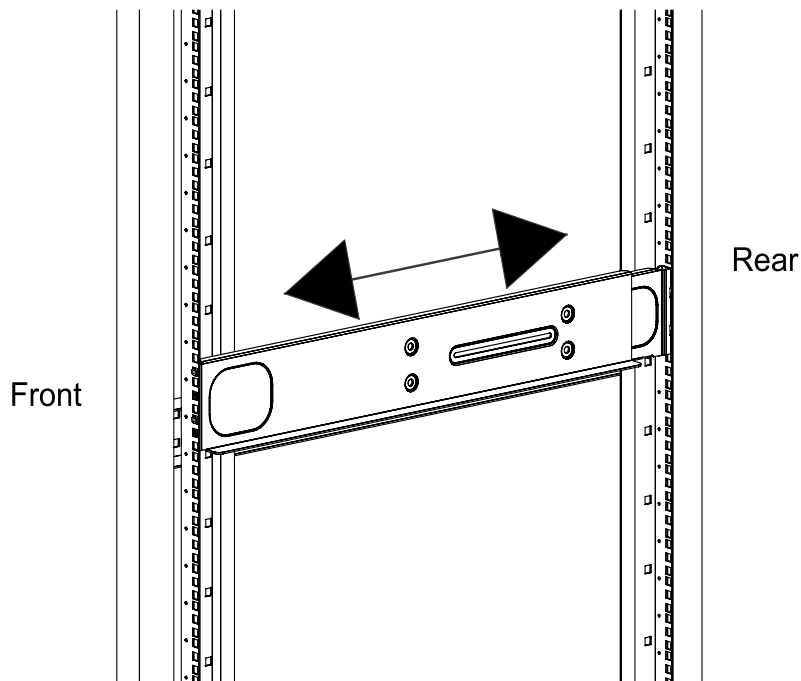

Figure 2-2. Securing the Rails to the Rack

## 2.3 Installing the Server

1. If you want to install the optional chassis handles, use screws including a thumbscrew through the bottom hole of each handle. **Note:** These handles need only be installed when mounting the system into a short rack. When mounting into a deep rack, they are unnecessary and regular screws should be used instead of thumbscrews.
2. With one person on either side, lift the system and slide it onto the installed rails.
3. After pushing the enclosure all the way into the rack, use the thumbscrew on each side of the server to lock it into place.

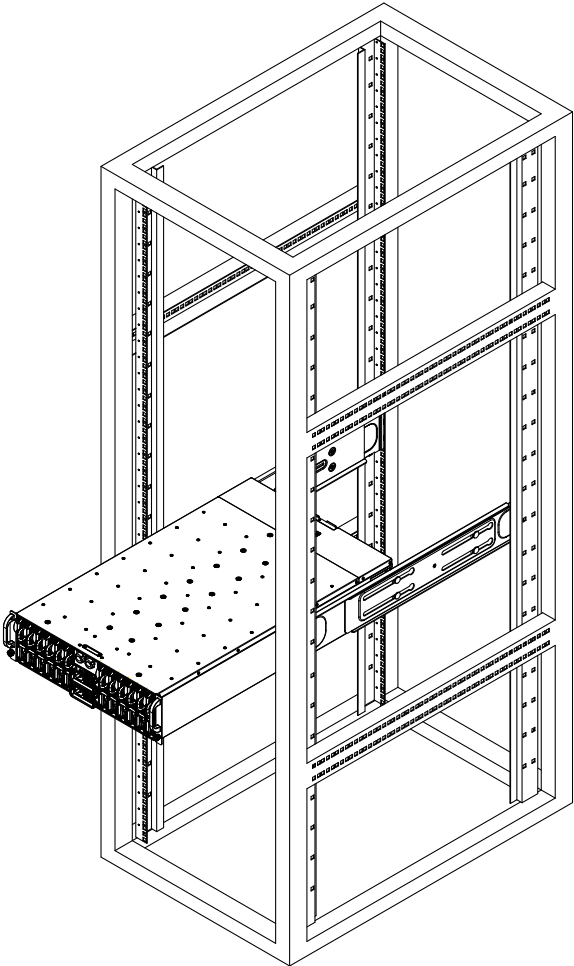

Figure 2-3. Installing the System into the Rack



Stability hazard. The rack stabilizing mechanism must be in place, or the rack must be bolted to the floor before you slide the unit out for servicing. Failure to stabilize the rack can cause the rack to tip over.

## Chapter 3

# Maintenance and Component Installation

This chapter provides instructions on installing and replacing main system components. To prevent compatibility issues, only use components that match the specifications and/or part numbers given.

Installation or replacement of most components require that power first be removed from the system. Please follow the procedures given in each section.

### 3.1 Removing Power

Use the following procedure to ensure that power has been removed from the system. This step is necessary when removing or installing non hot-swap components or when replacing a non-redundant power supply.

1. Use the operating system to power down the system.
2. After the system has completely shut-down, disconnect the AC power cord(s) from the power strip or outlet. (If your system has more than one power supply, remove the AC power cords from all power supply modules.)
3. Disconnect the power cord(s) from the power supply module(s).

## 3.2 Accessing the System

### Top Cover

A portion of the chassis top is removable to allow access to the system fans and backplane.

#### *Removing the Top Cover*

1. Remove power from the system as described in Section 3.1.
2. Remove the screws securing the cover to the chassis--four on top and two on each side. See Figure 3-1.
3. Lift the cover from the chassis.

**Caution:** Except for short periods of time, do not operate the server without the cover in place. The chassis cover must be in place to allow for proper airflow and to prevent overheating.

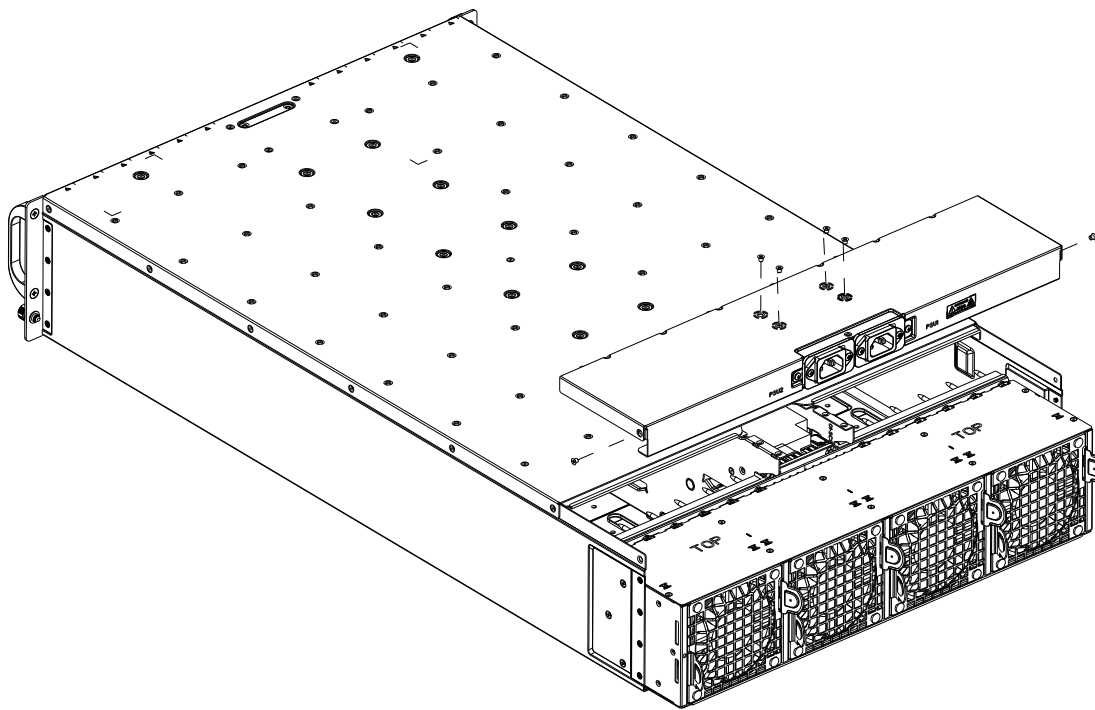
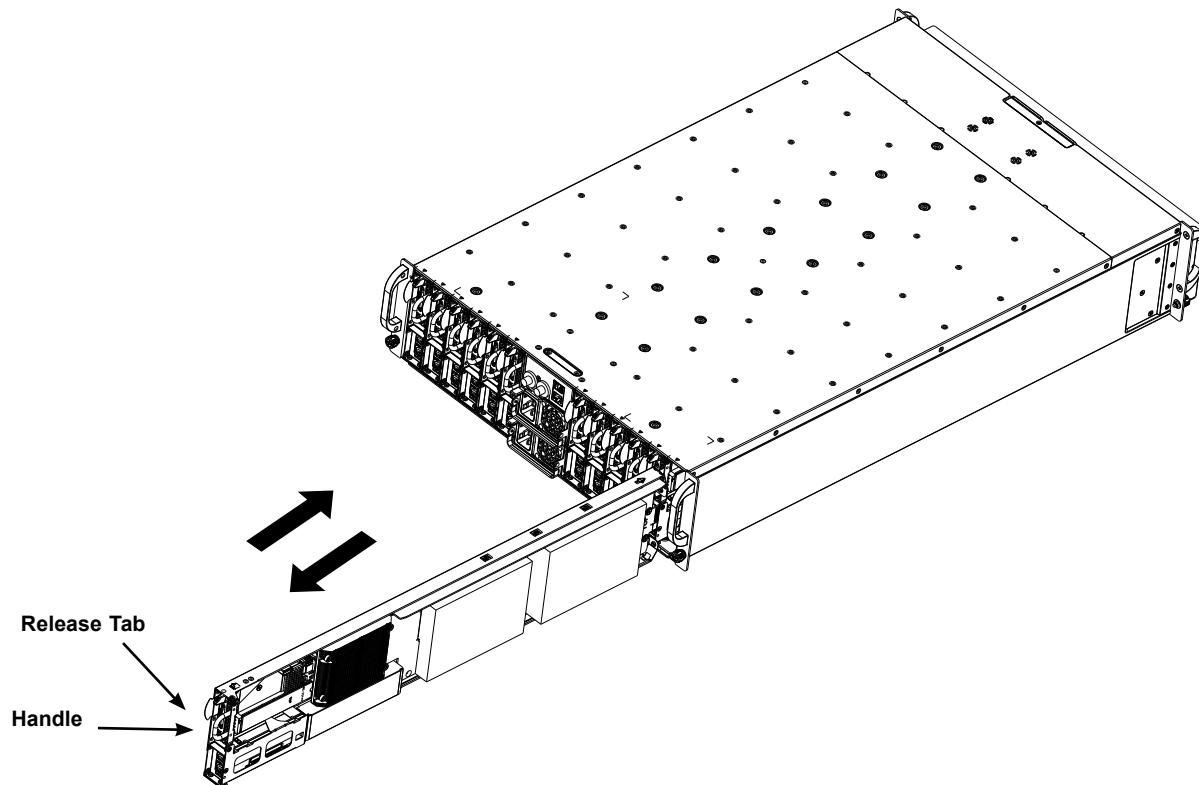

Figure 3-1. Removing the Chassis Cover

## Removing and Installing Motherboard Nodes

The system comes features twelve removable nodes. Each node contains an individual motherboard and hard drives mounted on a sled, which allows it to easily be installed and removed from the chassis.



**Figure 3-2. Removing/Installing a Node**

### ***Removing Nodes from the System***

1. Power-down the individual node by pressing that node's power button.
2. Press and hold down the release tab on the front of the node.
3. Use the node's handle to pull the node from the system.

**Caution:** Except for short periods of time while swapping nodes, do not operate the server with the node bays empty. In the unlikely event of a node failure, remove the failed node and replace it with the dummy node that was included with the system.

## Connecting to a Node

USB, COM, and serial port capabilities can be added to any node through the KVM port on the front. Plug in the adapter (dongle).

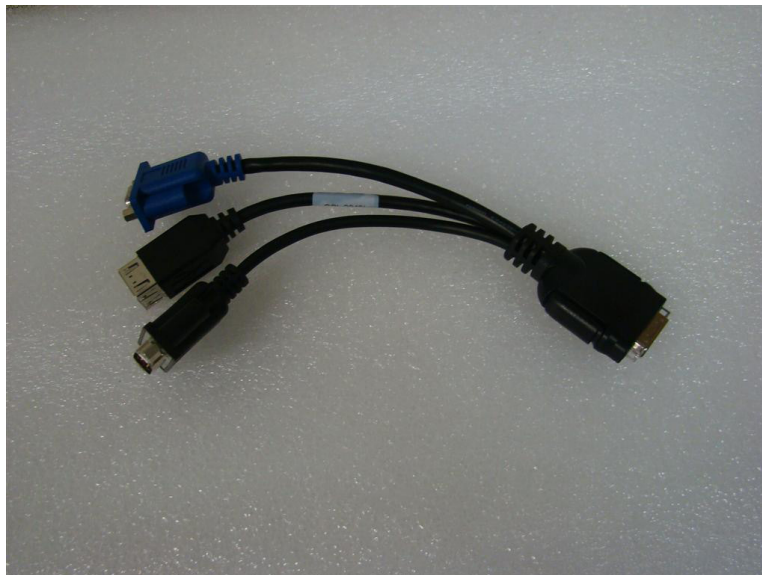

**Figure 3-3. Adapter to Provide USB, COM, and Serial Ports**

## 3.3 Motherboard Components

### Processor and Heatsink Installation

Follow the procedures in this section to install a processor (CPU) and heatsink onto the motherboard.

#### Notes:

- Be sure to use an Intel-certified multi-directional heatsink.
- When receiving a motherboard without a processor pre-installed, make sure that the plastic protective socket cover is in place and none of the socket pins are bent; otherwise, contact your retailer immediately.
- Refer to the Supermicro website for updates on CPU support.

#### Installing the Processor

1. Remove power from the system as described in Section 3.1.
2. Press the locking lever down and outward to release it, then lift it fully open. The load plate slides loose from the retaining post.

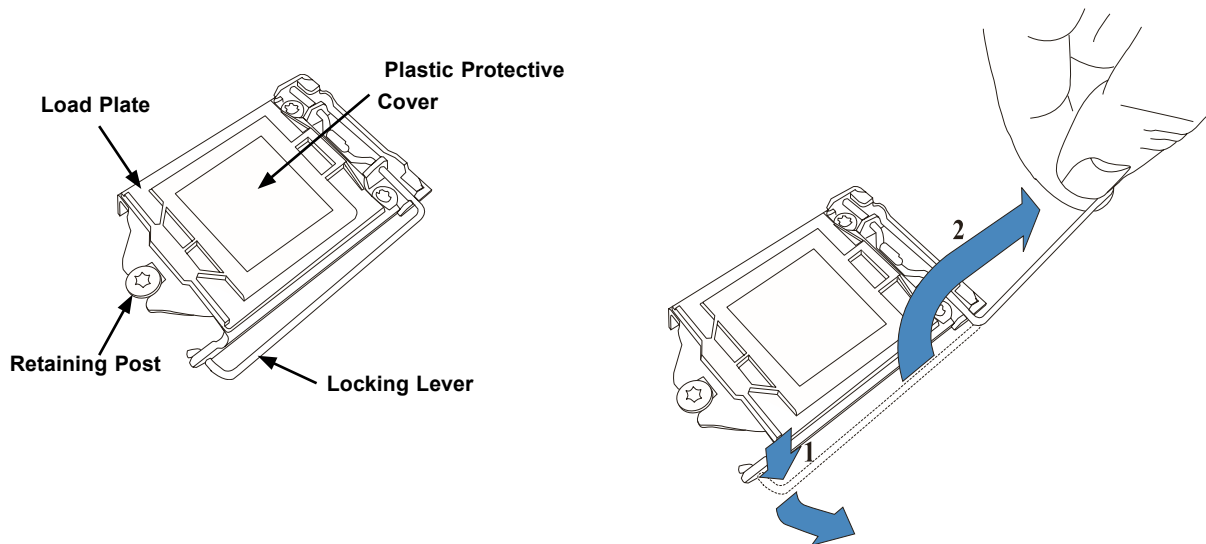
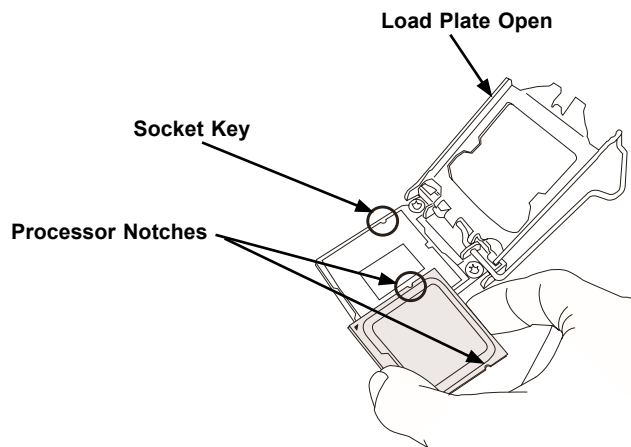

Figure 3-4. Releasing the Locking Lever

3. Lift open the load plate.



**Figure 3-5. Placing the Processor into the Socket**

4. Use your thumb and your index finger to hold the edges of the processor. Do not touch the socket contacts or the bottom of the processor. Align the notches (the semi-circle cutouts) on the processor with the socket keys.
5. Once aligned, carefully place the processor into the socket. Do not drop the processor on the socket, move or rub the processor against the socket or against any socket pins, as this may damage the components. Make sure the processor is properly aligned and seated in the socket, checking all corners.

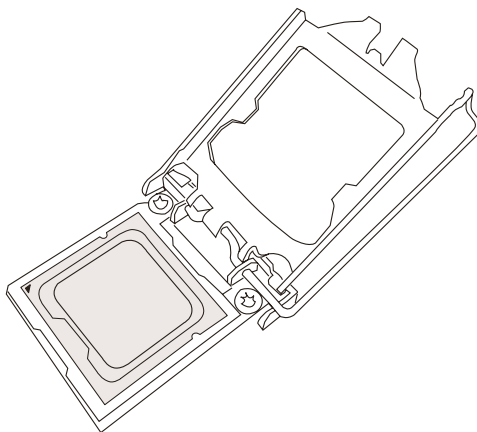

**Figure 3-6. Seating the Processor**

6. Gently close the load plate onto the processor. The plastic protective cover on the load plate will pop off. Save the cover to protect the socket if the processor is ever removed.
7. Making sure the slot in the load plate slides under the retaining post, close and latch the locking lever.

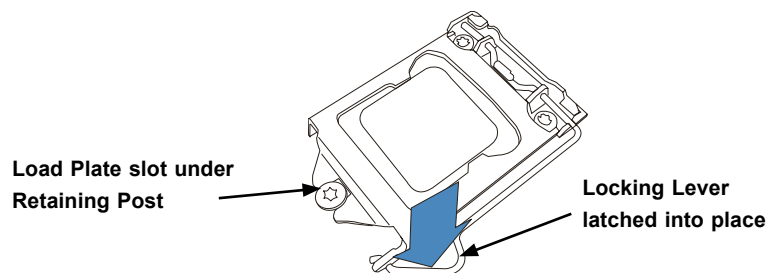

**Figure 3-7. Securing the Processor with the Socket Lever**

### ***Installing a Heatsink***

A passive type heatsink is used on the X11SCE-F motherboard.

**Note:** Do not apply any thermal grease to the heatsink or the CPU; the required amount has already been applied.

1. Place the heatsink on top of the CPU so that the four mounting holes are aligned with those on the heatsink retention mechanism.
2. Screw in two diagonal screws (i.e. the #1 and the #2 screws) until they are just snug. Do not fully tighten the screws or you may damage the CPU.
3. Add the two remaining screws then finish the installation by fully tightening all four screws (be careful not to overtighten).

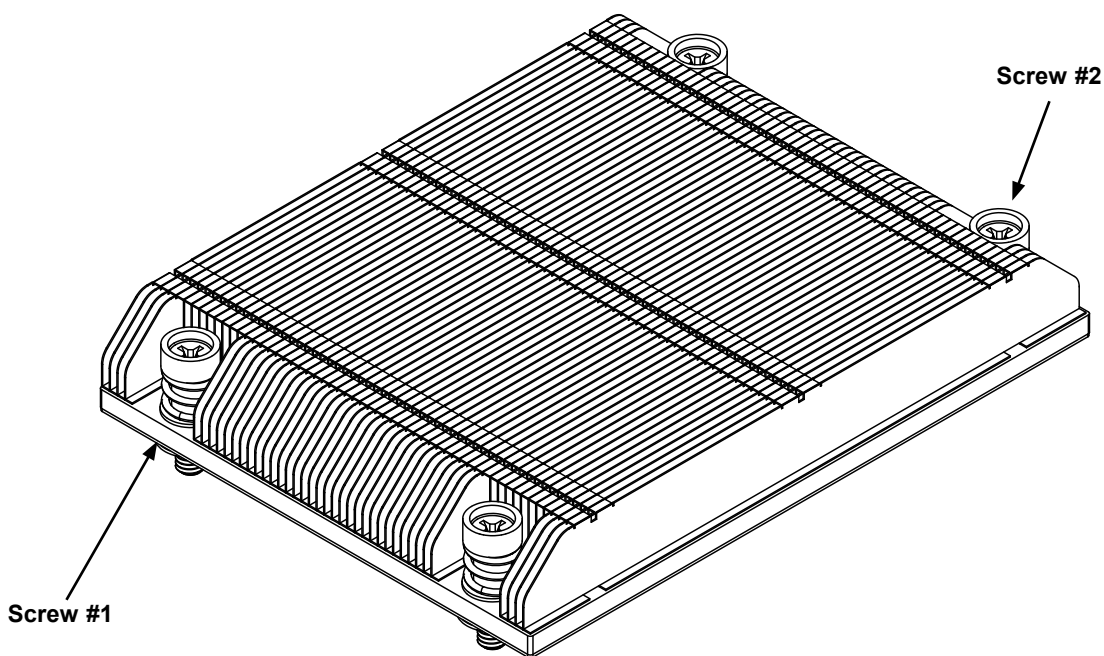

**Figure 3-8. Installing/Removing the Heatsink**

### ***Removing a Heatsink***

We do not recommend removing the heatsink. If necessary, please follow the instructions below to prevent damage to the CPU or the CPU socket.

1. Unscrew and remove the heatsink screws from the motherboard in the sequence as show in the figure above.
2. Hold and gently pivot the heatsink back and forth to loosen it from the CPU. (Do not use excessive force when dislodging the heatsink!)
3. Once the heatsink is loose, remove it from the CPU.
4. Clean the surface of the CPU and the heatsink to get rid of the old thermal grease. Reapply the proper amount of thermal grease to the surface before you re-install the heatsink.

## **Memory Installation**

### ***Memory Support***

The X11SCE-F supports up to 128GB of ECC Very Low Profile (VLP) DIMM with speeds of up to 2666MHz in four slots. Populating the DIMM slots with pairs of memory modules of the same type, speed, and size will result in interleaved memory, which improves performance.

Check the Supermicro website for possible updates to memory support.

### ***DIMM Module Population Configuration***

For optimal memory performance, follow the table below when populating memory.

<b>Recommended Population (Balanced)</b>				
<b>DIMMA1</b>	<b>DIMMB1</b>	<b>DIMMA2</b>	<b>DIMMB2</b>	<b>Total System Memory</b>
		4GB	4GB	8GB
4GB	4GB	4GB	4GB	16GB
		8GB	8GB	16GB
8GB	8GB	8GB	8GB	32GB
		16GB	16GB	32GB
16GB	16GB	16GB	16GB	64GB
		32GB	32GB	64GB
32GB	32GB	32GB	32GB	128GB

### ***DIMM Module Population Sequence***

When installing memory modules, the DIMM slots must be populated in the following order: DIMMB2, DIMMA2, then DIMMB1, DIMMA1. The blue slots must be populated first.

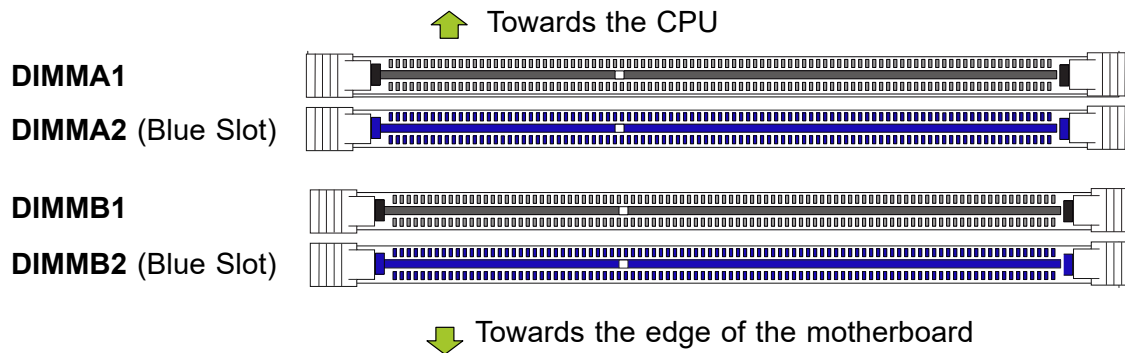

**Note:** Be sure to use memory modules of the same type and speed on the motherboard. Mixing of memory modules of different types and speeds is not allowed.

## ***Install Procedure***

### ***Installing Memory***

1. Remove power from the system as described in Section 3.1.

2. Starting with P1-DIMMA1, push the release tabs outwards on both ends of the DIMM slot to unlock it.

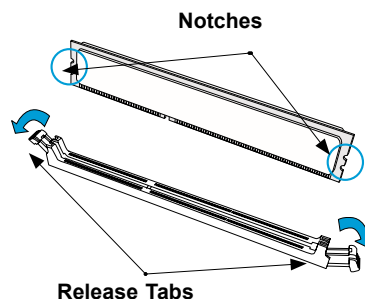

3. Align the key of the DIMM with the receptive point on the memory slot and with your thumbs on both ends of the module, press it straight down into the slot until the module snaps into place.

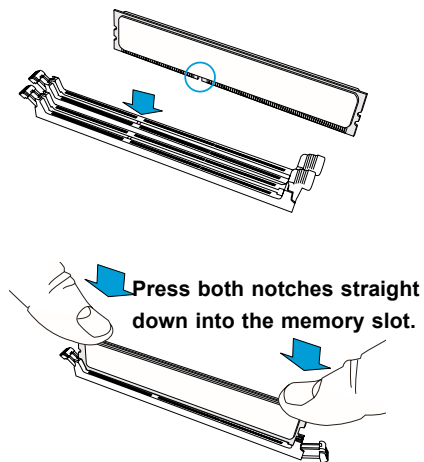

4. Press the release tabs to the locked position to secure the DIMM module into the slot.

5. Repeat the procedure for the remaining DIMM modules in the order detailed in the previous section.

**Caution:** Exercise extreme caution when installing or removing memory modules to prevent damage to the DIMMs or slots.

**Note:** Visit the product page on the Supermicro website for possible updates to memory support ([www.supermicro.com](http://www.supermicro.com)).

### ***Removal Procedure***

To remove a DIMM module, unlock the release tabs then pull the module from the slot.

## Expansion Module

Each of the twelve nodes includes a single MicroLP expansion module providing two LAN connections. Currently, there are four supported for the 5039MC-H12TRF system.

One Micro LP PCI-E 3.0 x8 slot

One M.2 PCI-E 3.0 x4 slot with SATA3 support, M-KEY 2280/22110

Two NVMe U.2 PCI-E x4 slots via the backplane

The MicroLP expansion module is inserted into a riser card and secured to two brackets as shown below. This assembly is inserted into the expansion slot on the motherboard and the rear bracket is secured to the rear of the node chassis.

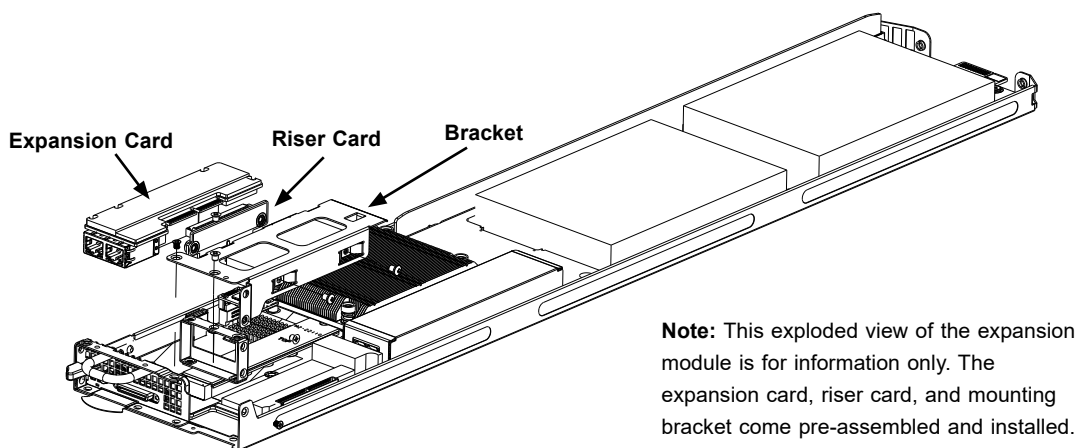

**Figure 3-9. MicroLP Expansion Module Assembly**

## Motherboard Battery

The motherboard uses non-volatile memory to retain system information when system power is removed. This memory is powered by a lithium battery residing on the motherboard.

### *Replacing the Battery*

1. Remove power from the system as described in section 3.1 and remove the node from the chassis.
2. Push aside the small clamp that covers the edge of the battery. When the battery is released, lift it out of the holder.
3. To insert a new battery, slide one edge under the lip of the holder with the positive (+) side facing up. Then push the other side down until the clamp snaps over it.

**Note:** Handle used batteries carefully. Do not damage the battery in any way; a damaged battery may release hazardous materials into the environment. Do not discard a used battery in the garbage or a public landfill. Please comply with the regulations set up by your local hazardous waste management agency to dispose of your used battery properly.

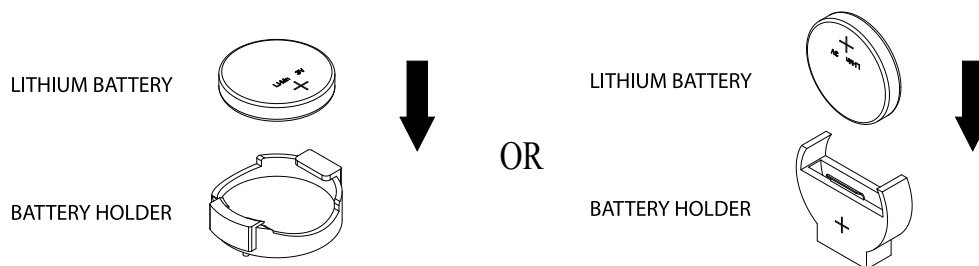

**Figure 3-10. Installing the Onboard Battery**

**Warning:** There is a danger of explosion if the onboard battery is installed upside down (which reverses its polarities). This battery must be replaced only with the same or an equivalent type recommended by the manufacturer (CR2032).

## 3.4 Chassis Components

### Hard Drives

The hard drives are installed directly to the node tray. For this reason, hard drives are not hot-swappable as the tray must be removed from the system. It supports two 3.5", four 2.5", or a combination of one 3.5" and two 2.5" hard drives in each node tray.

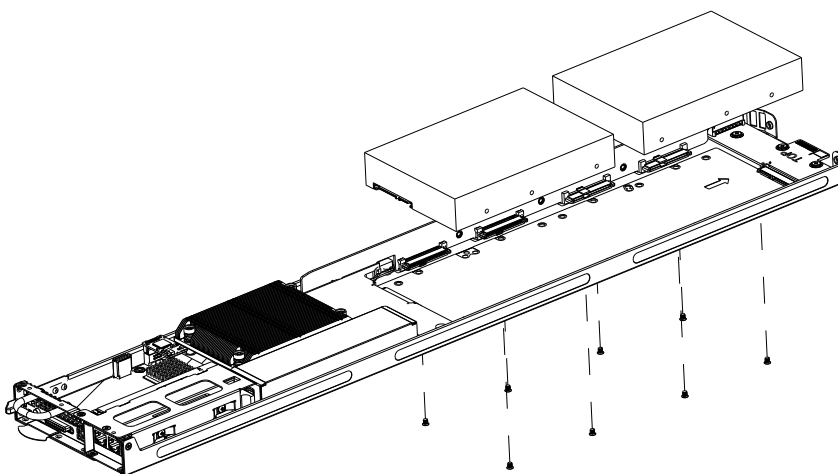
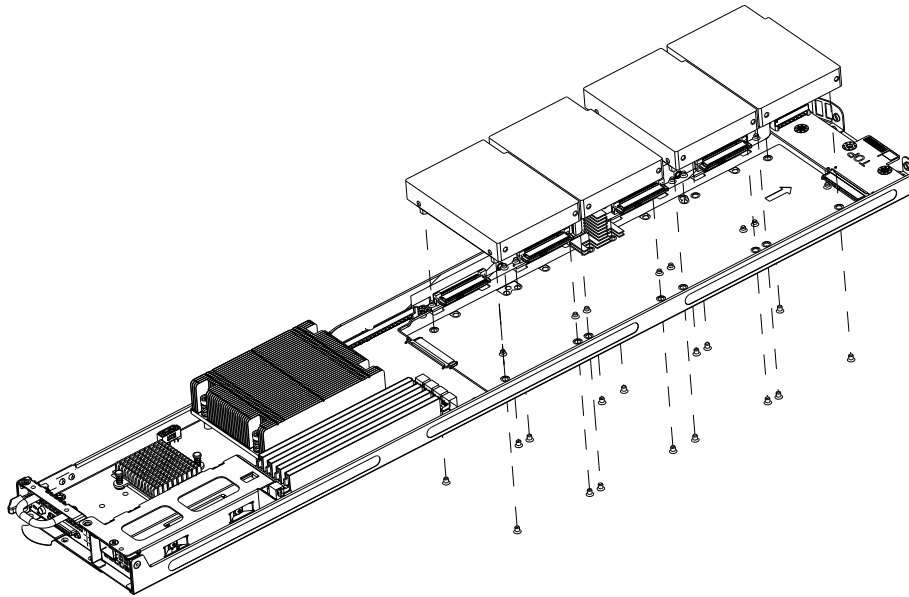

Figure 3-11.

### *Installing Hard Drives*

1. Power down the node and remove it from the chassis, following the procedure in Section 3.2.
2. Insert the hard drive with the printed circuit board side facing downward so that the mounting holes in the drive align with those in the bottom of the tray.
3. Secure the hard drive to the tray with the screws included with the drive.
4. Push the node back into the bay from which it was removed.
5. Power up the node, using the node power button.



**Figure 3-12.**

**Note:** Enterprise level hard disk drives are recommended for use in Supermicro chassis and servers. For information on recommended HDDs, visit the Supermicro Web site at <http://www.supermicro.com/products/nfo/storage.cfm>.

## System Cooling

### *Corresponding Nodes and Fans*

The 5039MC-H12TRF contains twelve individual motherboards contained in separate nodes. Three nodes each share a common fan (see figure below). By default, there is one fan zone for the entire system. This may be changed to two fan zones by opening jumper JP37 on the BPN-SAS-939HS. The figure below shows the two fan zone configuration.

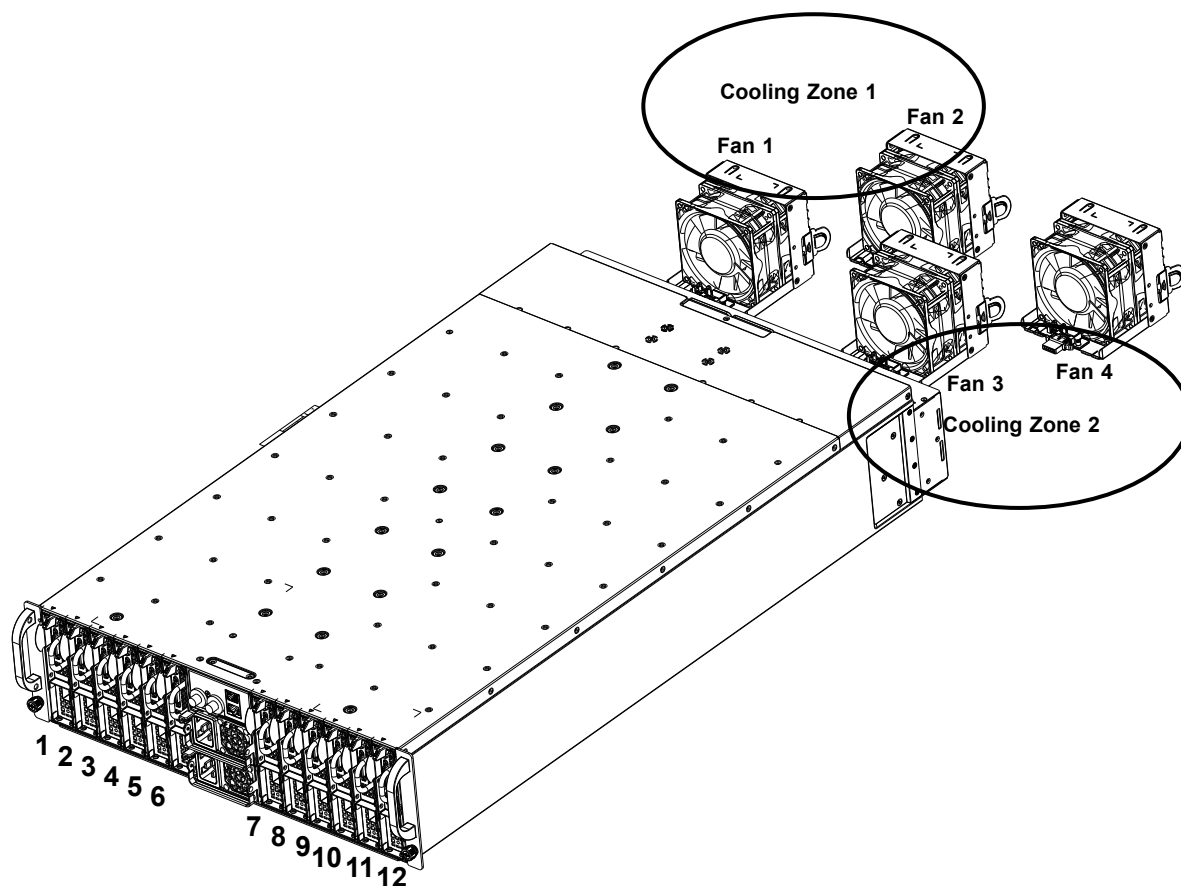

**Figure 3-13. Corresponding Nodes and Fans**

Corresponding Nodes and Fans		
Cooling Zone	Node	Fans
Zone 1	Nodes 1 through 6	Fans 1 & 2
Zone 2	Nodes 7 through 12	Fans 3 & 4

## ***Replacing Fans***

Four 9-cm fans circulate air through the chassis to lower the internal temperature. These fans are designed to be easily changed, with no tools required and no need to remove any other parts inside the chassis.

### ***Replacing a Fan***

1. Visually inspect the fans to see which one has failed.
2. Push both release tabs on the fan inward.
3. Remove the fan from the chassis. The wiring will disconnect automatically.
4. Insert a new fan into the housing, making sure that the air flow direction matches the other fans.
5. Confirm that the fan is working with the system powered on.

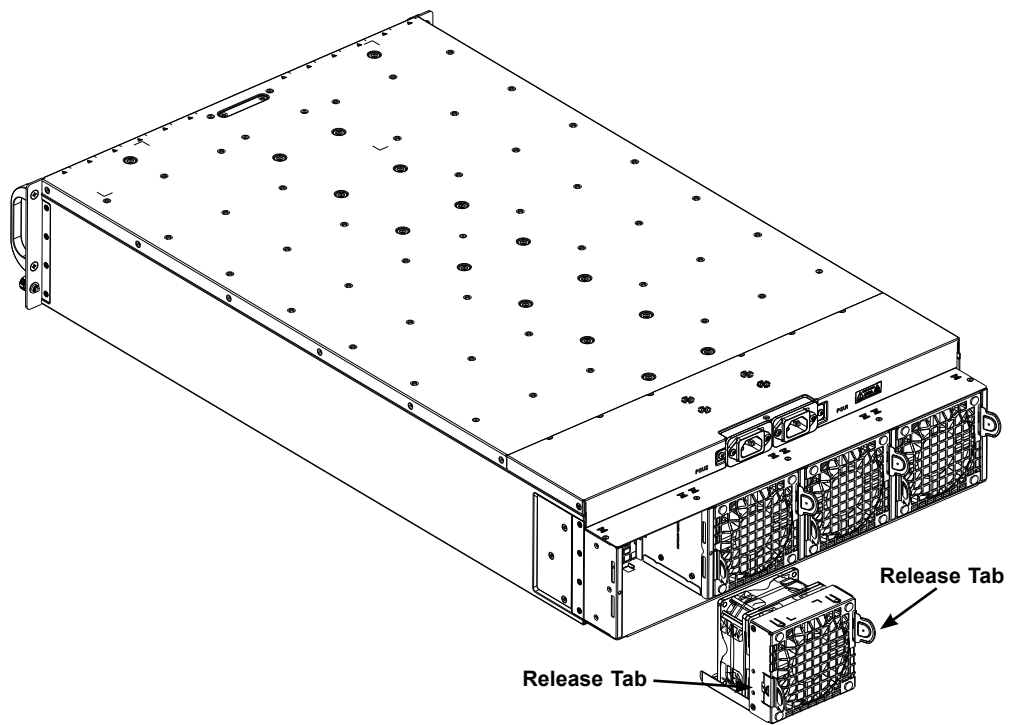

**Figure 3-14. Removing a Fan**

### ***Air Shroud***

The air shroud is used to concentrate airflow to maximize fan efficiency. The air shroud does not require screws to set up.

#### ***Installing the Air Shroud***

1. Remove the node from the chassis onto a flat, non-conductive surface.
2. If necessary, move any cables that interfere with the air shroud placement.
3. Place the air shroud in the chassis. It fits just beside the heatsink and behind the LAN add-on card.
4. Hook the shroud on DIMM latch without screws. Easily unhook to release.

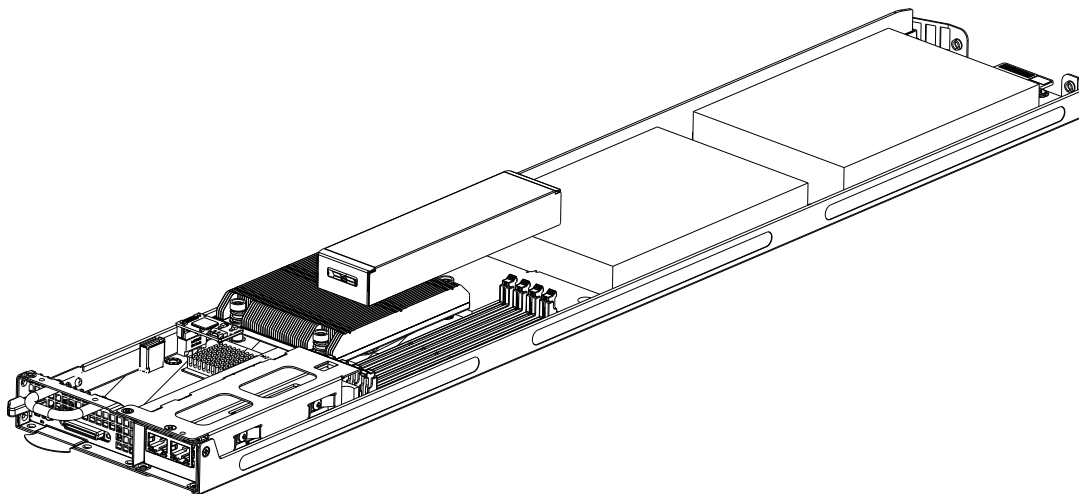

**Figure 3-15. Installing the Air Shroud**

## Power Supply

The chassis features redundant power supplies. They are hot-swappable, meaning they can be changed without powering down the system. New units can be ordered directly from Supermicro or authorized distributors.

These power supplies are auto-switching capable. This feature enables them to automatically sense the input voltage and operate at a 100-120v or 180-240v. An amber light will be illuminated on the power supply when the power is off. An illuminated green light indicates that the power supply is operating.

### *Changing the Power Supply*

1. With the system running, unplug the AC power cord that provide power to the failed module.
2. Press and hold the release tab on the front, top of the power module.
3. Grasp the handle and pull the power supply out of its bay.
4. Push the replacement power supply module into the empty bay until it clicks into the locked position.
5. Plug the AC power cord back into the power supply module.

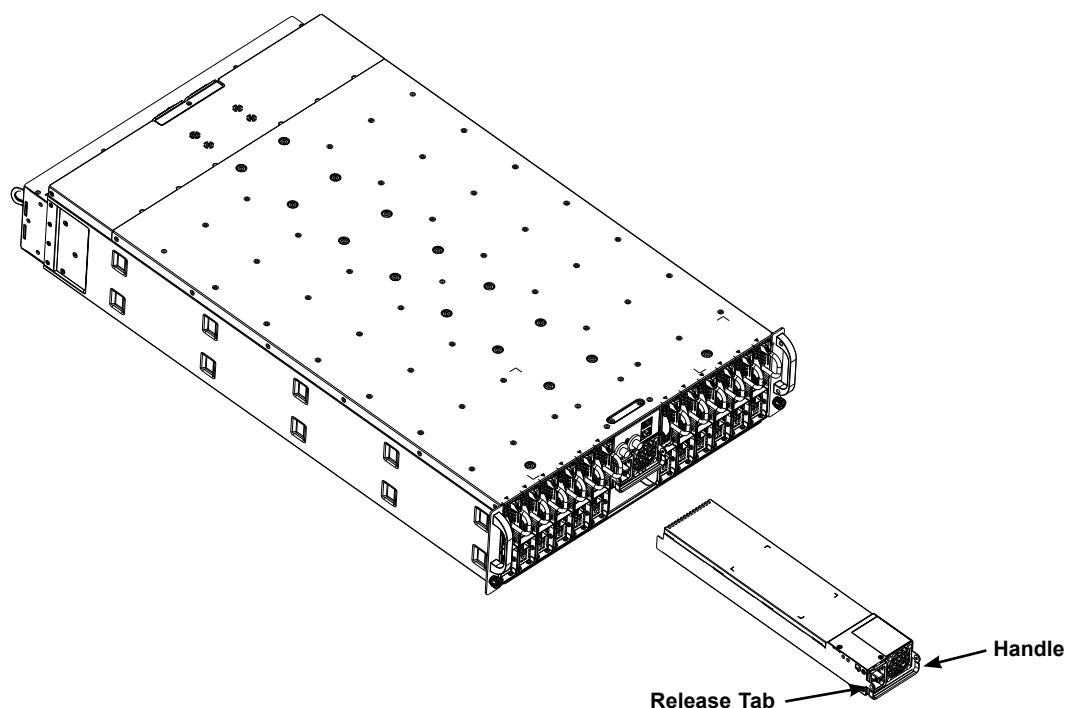

**Figure 3-16. Replacing a Power Supply Module**

# Chapter 4

## Motherboard Connections

This section describes the connections on the motherboard and provides pinout definitions. Note that depending on how the system is configured, not all connections are required. The LEDs on the motherboard are also described here. A motherboard layout indicating component locations may be found in Chapter 1.

Please review the safety precautions in Appendix B before installing or removing components.

### 4.1 Node Front Panel Controls

#### Power Button/LED

There is an On/Off button (SW2) with integrated LED on the I/O panel of each node. The function is described in Chapter 1.

#### Unit Identifier Switch/UID LED Indicator

A Unit Identifier (UID) switch and an LED Indicator are located on the motherboard. The UID switch is located at JUIDB1, which is next to the VGA port on the I/O panel. The UID LED (LED5) is located next to the UID switch. When you press the UID switch, the UID LED will be turned on. Press the UID switch again to turn off the LED indicator. The UID Indicator provides easy identification of a system unit that may be in need of service.

**Note:** UID can also be triggered using IPMI on the motherboard. For more information on IPMI, please refer to the IPMI User's Guide posted on our website at <http://www.supermicro.com>.

### 4.2 Headers and Connectors

#### TPM Header

The JTPM1 header is used to connect a Trusted Platform Module (TPM)/Port 80, which is available from a third-party vendor. A TPM/Port 80 connector is a security device that supports encryption and authentication in hard drives. It allows the motherboard to deny access if the aTPM associated with the hard drive is not installed in the system. Go to the following link for more information on the TPM: <http://www.supermicro.com/manuals/other/TPM.pdf>.

Trusted Platform Module Header Pin Definitions			
Pin#	Definition	Pin#	Definition
1	+3.3V	2	SPI_CS#
3	RESET#	4	SPI_MISO
5	SPI_CLK	6	GND
7	SPI_MOSI	8	
9	+3.3V Stby	10	SPI_IRQ#

### **KVM Connector**

The JKVM1 connector is an acronym for Keyboard, Video, and Mouse. The connector supports a set of keyboard, monitor, and mouse to control multiple computers. It also provides a VGA connection, serial port connection, and two USB 2.0 connections (USB0/1).



### **Backplane Connector**

The backplane connector at J22 provides four SATA 3.0 connections or two NVMe PCI-E 3.0 x4 connections.

## **4.3 Ports**

### **I-SATA 3.0 Ports**

The X11SCE-F has five I-SATA 3.0 ports via the backplane, one on the motherboard to support M.2 connector. These SATA ports are supported by the Intel C246 PCH chipset.

**Note 1:** I-SATA2 though I-SATA6 J22 require an Add-On Module (AOM) for hard drive connection.

**Note 2:** For more information on the SATA HostRAID configuration, please refer to the Intel SATA HostRAID user's guide posted on our website at <http://www.supermicro.com>.

### **M.2 Slots**

There is one M.2 slot at J25 which is designed for internal mounting devices and provides M Key 2280/22110 support PCI-E 3.0 x4 or SATA 3.0 SSD device.

### **Power Button**

Press the button at SW2 to power on the motherboard. This button can also power off the motherboard instantly or in four seconds. The settings for this button can be configured with the Power Button Function feature in the BIOS.

## Unit Identifier Switch/UID LED Indicator

A Unit Identifier (UID) switch and an LED indicator are located on the motherboard. The UID switch is located at UID, on the back panel. The UID LED (LED5) is located next to the UID switch. When you press the UID button, the UID LED will be turned on. Press the switch again to turn off the LED indicator. The UID Indicator provides easy identification of a system unit that may be in need of service.

**Note:** UID can also be triggered via IPMI on the motherboard. For more information on IPMI, please refer to the IPMI User's Guide posted on our website at <http://www.supermicro.com/support/manuals/>.

UID LED Pin Definitions	
Color	Status
Blue: On	Unit Identified

UID Switch Pin Definitions	
Pin#	Definition
1	Ground
2	Ground
3	Button In
4	Button In

## 4.4 Jumpers

### Explanation of Jumpers

To modify the operation of the motherboard, jumpers are used to choose between optional settings. Jumpers create shorts between two pins to change the function associated with it. Pin 1 is identified with a square solder pad on the printed circuit board. See the motherboard layout page for jumper locations.

**Note:** On a two-pin jumper, "Closed" means the jumper is on both pins and "Open" indicates the jumper is either on only one pin or has been completely removed.

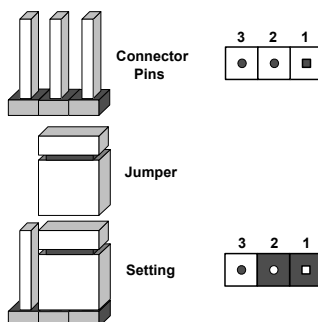

## CMOS Clear

JBT1 is used to clear CMOS, which will also clear any passwords. Instead of pins, this jumper consists of contact pads to prevent accidentally clearing the contents of CMOS.

### To Clear CMOS

1. First power down the system and unplug the power cord(s).
2. Remove the cover of the chassis to access the motherboard.
3. Remove the onboard battery from the motherboard.
4. Short the CMOS pads with a metal object such as a small screwdriver for at least four seconds.
5. Remove the screwdriver (or shorting device).
6. Replace the cover, reconnect the power cord(s) and power on the system.

**Note:** Clearing CMOS will also clear all passwords.

Do not use the PW\_ON connector to clear CMOS.



JBT1 contact pads

## Management Engine (ME) Recovery

Use jumper JPME1 to select ME Firmware Recovery mode, which will limit resource allocation for essential system operation only in order to maintain normal power operation and management. In the single operation mode, online upgrade will be available via Recovery mode. See the table below for jumper settings.

Manufacturer Mode Jumper Settings	
Jumper Setting	Definition
Pins 1-2	Normal
Pins 2-3	ME Recovery

## ME Manufacturing Mode

Close JPME2 to bypass SPI flash security and force the system to use the Manufacturing Mode, which will allow the user to flash the system firmware from a host server to modify system settings. Refer to the table below for jumper settings.

Manufacturing Mode Jumper Settings	
Jumper Setting	Definition
Pins 1-2	Normal (Default)
Pins 2-3	Manufacturing Mode

### VGA Enable/Disable

JPG1 allows you to enable or disable the VGA port using the onboard graphics controller. The default setting is Enabled.

VGA Enable/Disable Jumper Settings	
Jumper Setting	Definition
Pins 1-2	Enabled
Pins 2-3	Disabled

### Watch Dog

JWD1 controls the Watch Dog function. Watch Dog is a monitor that can reboot the system when a software application hangs. Jumping pins 1-2 will cause Watch Dog to reset the system if an application hangs. Jumping pins 2-3 will generate a non-maskable interrupt signal for the application that hangs. Watch Dog must also be enabled in BIOS.

The default setting is Reset.

**Note:** When Watch Dog is enabled, the user needs to write their own application software to disable it.

Watch Dog Jumper Settings	
Jumper Setting	Definition
Pins 1-2	Reset (Default)
Pins 2-3	NMI
Open	Disabled

## 4.5 LED Indicators

### BMC Heartbeat LED

BMC\_HB\_LED1 is the BMC heartbeat LED. When the LED is blinking green, BMC is functioning normal. Refer to the table below for more information.

BMC Heartbeat LED Indicator	
LED Color	Definition
Green: Blinking	BMC: Normal

### Overheat/Fan Fail LED

An Overheat and Fan Fail LED is located at LED5. Refer to the table below for the LED status.

Overheat/Fan Fail LED Indicator	
LED Color	Definition
Solid	Overheat
Blinking	Fan Failure or Power Failure

# Chapter 5

## Software

After the hardware has been installed, you can install the Operating System (OS), configure RAID settings, and install the drivers.

### 5.1 Microsoft Windows OS Installation

If you will be using RAID, you must configure RAID settings before installing the Windows OS and the RAID driver. Refer to the RAID Configuration User Guides posted on our website at [www.supermicro.com/support/manuals](http://www.supermicro.com/support/manuals).

#### *Installing the OS*

1. Create a method to access the MS Windows installation ISO file. That might be a DVD, perhaps using an external USB/SATA DVD drive, or a USB flash drive, or the IPMI KVM console.
2. Retrieve the proper RST/RSTe driver. Go to the Supermicro web page for your motherboard and click on "Download the Latest Drivers and Utilities", select the proper driver, and copy it to a USB flash drive.
3. Boot from a bootable device with Windows OS installation. You can see a bootable device list by pressing **F11** during the system startup.

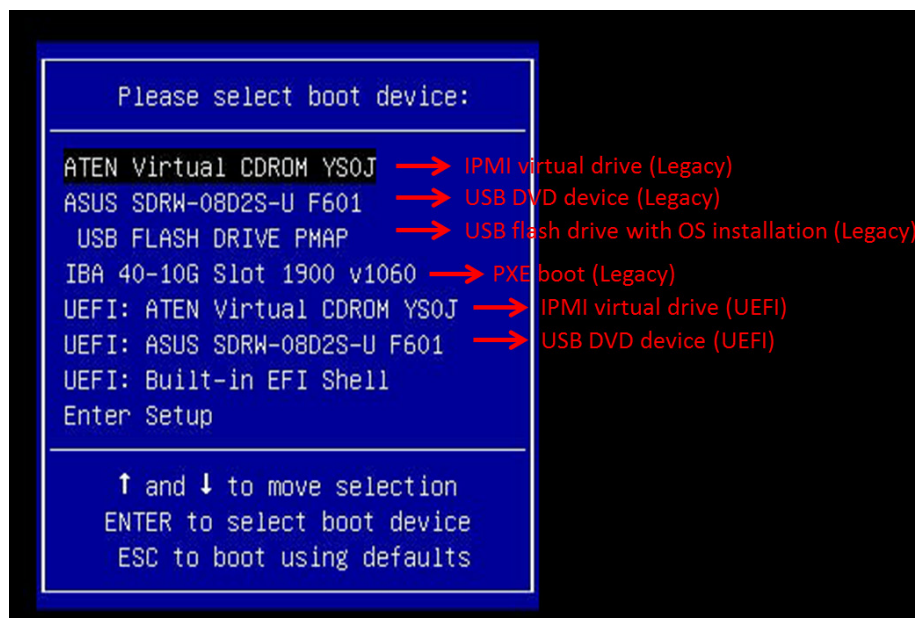

**Figure 5-1. Select Boot Device**

4. During Windows Setup, continue to the dialog where you select the drives on which to install Windows. If the disk you want to use is not listed, click on “Load driver” link at the bottom left corner.

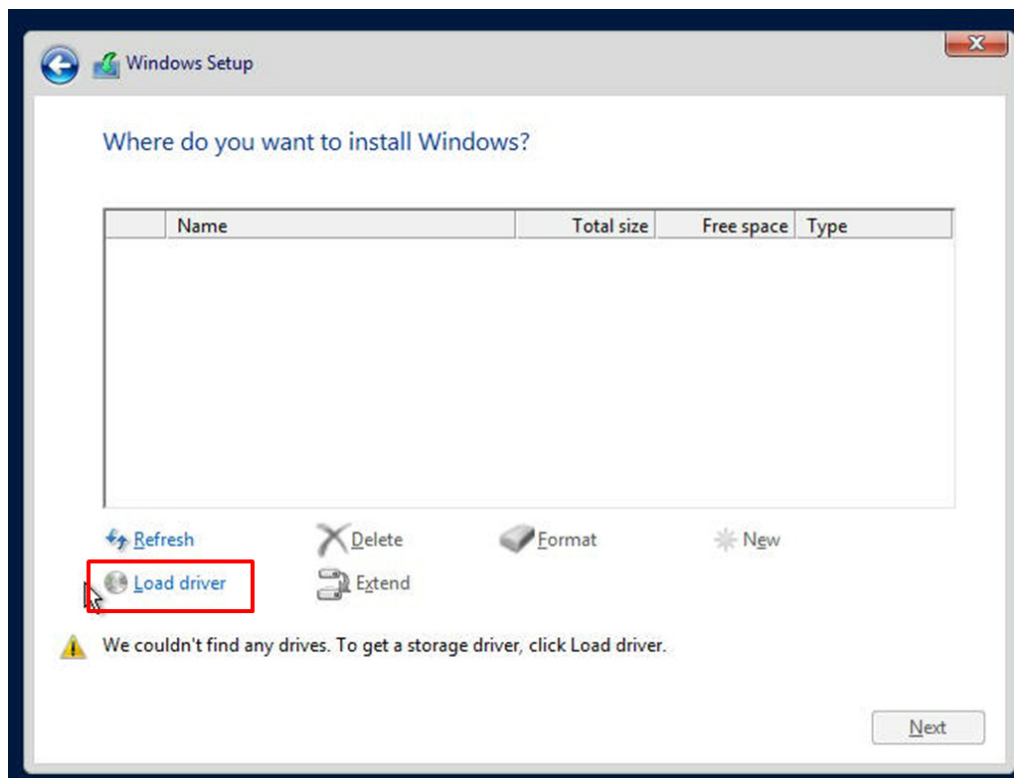

**Figure 5-2. Load Driver Link**

To load the driver, browse the USB flash drive for the proper driver files.

- For RAID, choose the SATA/sSATA RAID driver indicated then choose the storage drive on which you want to install it.
  - For non-RAID, choose the SATA/sSATA AHCI driver indicated then choose the storage drive on which you want to install it.
5. Once all devices are specified, continue with the installation.
  6. After the Windows OS installation has completed, the system will automatically reboot multiple times.

## 5.2 Driver Installation

The Supermicro FTP site contains drivers and utilities for your system at <https://www.supermicro.com/wdl/driver>. Some of these must be installed, such as the chipset driver.

After accessing the FTP site, go into the CDR\_Images directory and locate the ISO file for your motherboard. Download this file to create a DVD of the drivers and utilities it contains. (You may also use a utility to extract the ISO file if preferred.)

After creating a DVD with the ISO files, insert the disk into the DVD drive on your system and the display shown in Figure 5-1 should appear.

Another option is to go to the Supermicro website at <http://www.supermicro.com/products/>. Find the product page for your motherboard here, where you may download individual drivers and utilities to your hard drive or a USB flash drive and install from there.

**Note:** To install the Windows OS, please refer to the instructions posted on our website at <http://www.supermicro.com/support/manuals/>.

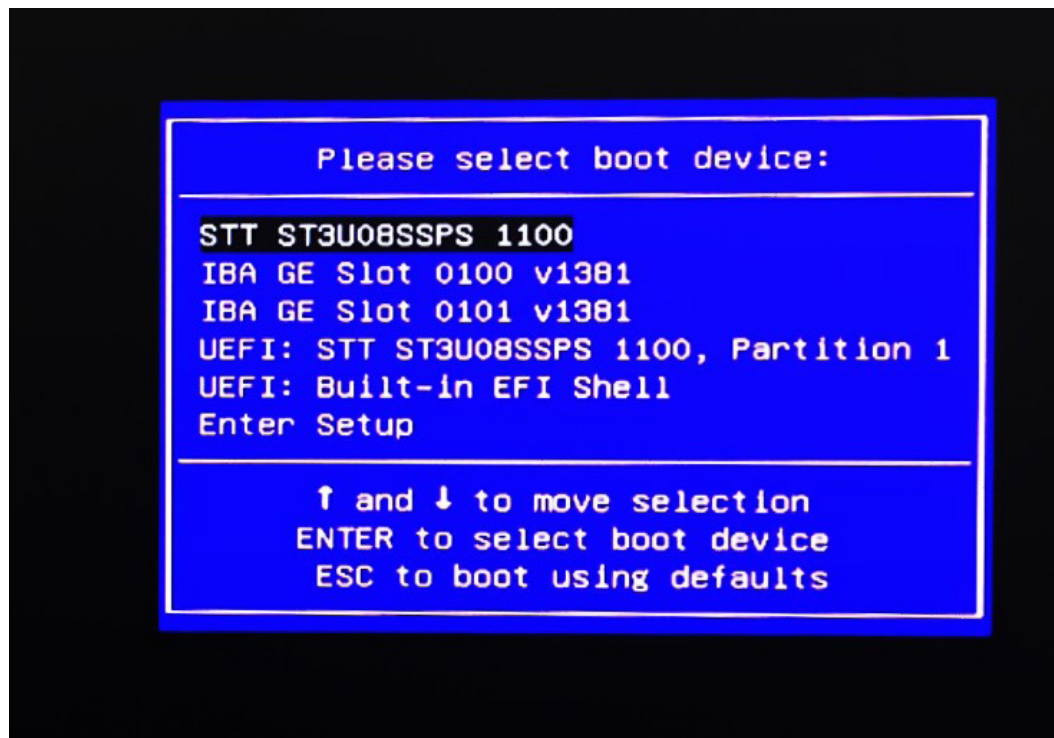

Figure 5-1. Driver & Tool Installation Screen

**Note:** Click the icons showing a hand writing on paper to view the readme files for each item. Click the computer icons to the right of these items to install each item (from top to the bottom) one at a time. **After installing each item, you must re-boot the system before moving on to the next item on the list.** The bottom icon with a CD on it allows you to view the entire contents.

## 5.3 SuperDoctor® 5

The Supermicro SuperDoctor 5 is a program that functions in a command-line or web-based interface for Windows and Linux operating systems. The program monitors such system health information as CPU temperature, system voltages, system power consumption, fan speed, and provides alerts via email or Simple Network Management Protocol (SNMP).

SuperDoctor 5 comes in local and remote management versions and can be used with Nagios to maximize your system monitoring needs. With SuperDoctor 5 Management Server (SSM Server), you can remotely control power on/off and reset chassis intrusion for multiple systems with SuperDoctor 5 or IPMI. SuperDoctor 5 Management Server monitors HTTP, FTP, and SMTP services to optimize the efficiency of your operation.

**Note:** The default User Name and Password for SuperDoctor 5 is ADMIN/ADMIN.



Figure 5-2. SuperDoctor 5 Interface Display Screen (Health Information)

## 5.4 IPMI

The X11SCE-F supports the Intelligent Platform Interface (IPMI). IPMI is used to provide remote access, monitoring, and management. There are several BIOS settings that are related to IPMI.

IPMI management capabilities for all nodes IPMI are supported when one of two dedicated LAN ports are connected (Figure 1-2). Multi node information and the system information can be displayed at the same time.

In IPMI Web GUI view, information can be displayed by clicking the "Multi Node" tab under the "Server Health" drop down menu. To access the other nodes within the same enclosure, click the IP address of the other nodes.

In IPMI CLI view, typing the command "SMCIPMITool -tp info", allows the MCU information of all 12 nodes to be displayed.

For general documentation and information on IPMI, please visit our website at: <http://www.supermicro.com/products/nfo/IPMI.cfm>.

# Chapter 6

## BIOS

### 6.1 Introduction

This chapter describes the AMIBIOS Setup utility for the X11SCE-F motherboard. The BIOS is stored in a flash chip and can be easily upgraded using a floppy disk-based program.

**Note:** Due to periodic changes to the BIOS, some settings may have been added or deleted and might not yet be recorded in this manual. Please refer to the Manual Download area of our website for any changes to BIOS that may not be reflected in this manual.

#### Starting the Setup Utility

To enter the BIOS Setup Utility, hit the <Delete> key while the system is booting-up. (In most cases, the <Delete> key is used to invoke the BIOS setup screen. There are a few cases when other keys are used, such as <F1>, <F2>, etc.) Each main BIOS menu option is described in this manual.

The Main BIOS screen has two main frames. The left frame displays all the options that can be configured. "Grayed-out" options cannot be configured. The right frame displays the key legend. Above the key legend is an area reserved for a text message. When an option is selected in the left frame, it is highlighted in white. Often a text message will accompany it. (Note that BIOS has default text messages built in. We retain the option to include, omit, or change any of these text messages.) Settings printed in **Bold** are the default values.

A " ►" indicates a submenu. Highlighting such an item and pressing the <Enter> key will open the list of settings within that submenu.

The BIOS setup utility uses a key-based navigation system called hot keys. Most of these hot keys (<F1>, <F10>, <Enter>, <ESC>, <Arrow> keys, etc.) can be used at any time during the setup navigation process.

## 6.2 Main Menu

When you first enter AMI BIOS Setup Utility, you see the Main Menu screen. You can always return to the Main Menu by selecting the Main tab on the top of the screen with the arrow keys.

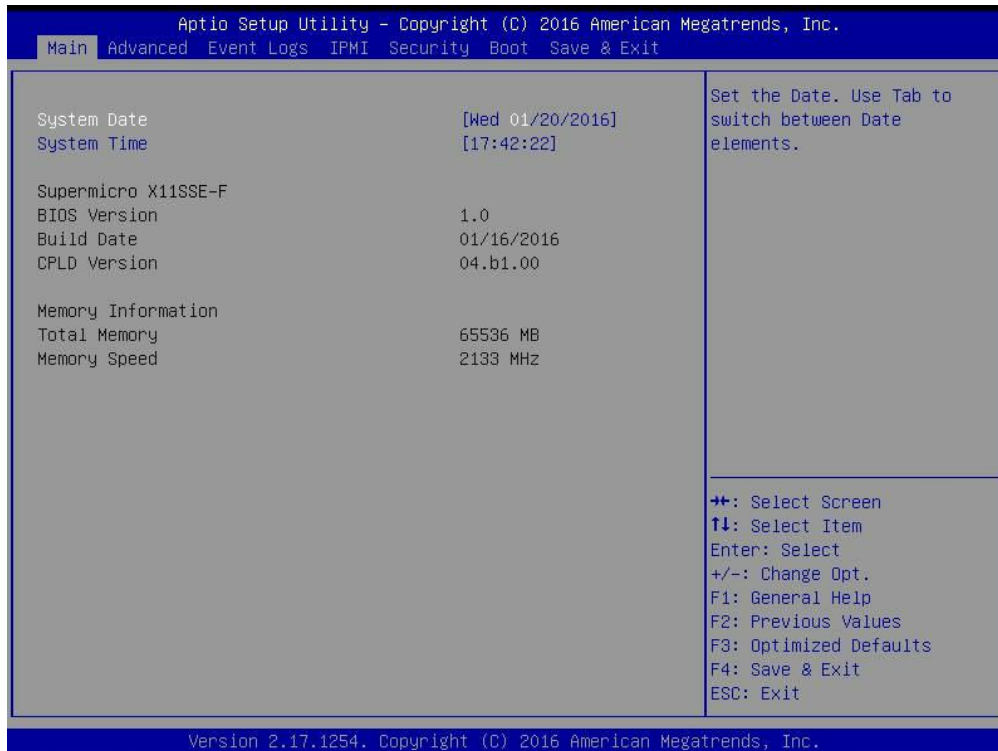

The Main Menu screen provides you with a system overview, which includes the version, built date and ID of the AMIBIOS, the type, speed and number of the processors in the system and the amount of memory installed in the system.

### System Time/System Date

You can edit this field to change the system time and date. Highlight System Time or System Date using the <Arrow> keys. Enter new values through the keyboard. Press the <Tab> key or the <Arrow> keys to move between fields. The date must be entered in DAY/MM/DD/YYYY format. The time is entered in HH:MM:SS format. Please note that time is in a 24-hour format. For example, 5:30 A.M. appears as 05:30:00 and 5:30 P.M. as 17:30:00.

### Supermicro X11SCE-F

#### BIOS Version

This item displays the version of the BIOS ROM used in the system.

#### Build Date

This item displays the date when the version of the BIOS ROM used in the system was built.

#### CPLD Version

## Memory Information

### Total Memory

This item displays the total size of memory available in the system.

### Memory Speed

This item displays the memory speed.

## 6.3 Advanced Setup Configurations

**Caution:** Take caution when changing the Advanced settings. An incorrect value, a very high DRAM frequency, or an incorrect DRAM timing setting may make the system unstable. When this occurs, revert to the default to the manufacture default settings.

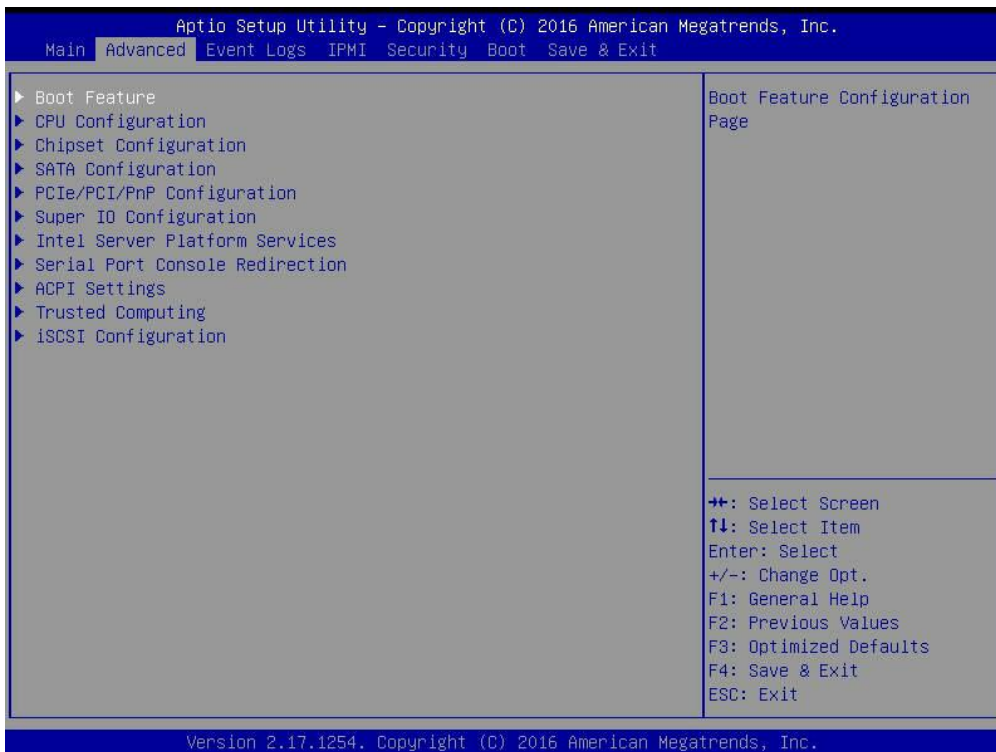

Use the arrow keys to select Boot Setup and press <Enter> to access the submenu items.

### ▶ Boot Feature

#### Quiet Boot

Use this feature to select the screen display between the POST messages and the OEM logo upon bootup. Select Disabled to display the POST messages. Select Enabled to display the OEM logo instead of the normal POST messages. The options are **Enabled** and Disabled.

**AddOn ROM Display Mode**

Use this feature to set the display mode for the Option ROM. Select Keep Current to display the current AddOn ROM setting. Select Force BIOS to use the Option ROM display set by the system BIOS. The options are **Force BIOS** and Keep Current.

**Bootup NumLock State**

Use this feature to set the Power-on state for the <Numlock> key. The options are Off and **On**.

**Wait For 'F1' If Error**

Use this feature to force the system to wait until the 'F1' key is pressed if an error occurs. The options are Disabled and **Enabled**.

**INT19 (Interrupt 19) Trap Response**

Interrupt 19 is the software interrupt that handles the boot disk function. When this item is set to Immediate, the ROM BIOS of the host adaptors will "capture" Interrupt 19 at bootup immediately and allow the drives that are attached to these host adaptors to function as bootable disks. If this item is set to Postponed, the ROM BIOS of the host adaptors will not capture Interrupt 19 immediately and allow the drives attached to these adaptors to function as bootable devices at bootup. The options are **Immediate** and Postponed.

**Re-try Boot**

If this item is enabled, the BIOS will automatically reboot the system from a specified boot device after its initial boot failure. The options are **Disabled**, Legacy Boot, and EFI Boot.

**Install Windows 7 USB Support**

Enable this feature to use the USB keyboard and mouse during the Windows 7 installation, since the native XHCI driver support is unavailable. Use a SATA optical drive as a USB drive, and USB CD/DVD drives are not supported. Disable this feature after the XHCI driver has been installed in Windows. The options are **Disabled** and Enabled.

**►Power Configuration****Watch Dog Function**

If enabled, the Watch Dog Timer will allow the system to reset or generate NMI based on jumper settings when it is expired for more than 5 minutes. The options are Enabled and **Disabled**.

**Power Button Function**

This feature controls how the system shuts down when the power button is pressed. Select 4 Seconds Override for the user to power off the system after pressing and holding the power button for 4 seconds or longer. Select Instant Off to instantly power off the system as soon as the user presses the power button. The options are 4 Seconds Override and **Instant Off**.

### **Restore on AC Power Loss**

Use this feature to set the power state after a power outage. Select Stay-Off for the system power to remain off after a power loss. Select Power-On for the system power to be turned on after a power loss. Select Last State to allow the system to resume its last power state before a power loss. The options are Power-On, Stay-Off, and **Last State**.

### **► CPU Configuration**

The following CPU information will display:

- CPU Signature
- Microcode Patch
- Max CPU Speed
- Min CPU Speed
- CPU Speed
- Processor Cores
- Hyper Threading Technology
- Intel VT-x Technology
- Intel SMX Technology
- 64-bit
- EIST Technology
- CPU C3 State
- CPU C6 State
- CPU C7 State
- L1 Data Cache
- L1 Code Cache
- L2 Cache
- L3 Cache
- L4 Cache

**Hyper-threading (Available when supported by the CPU)**

Select Enabled to support Intel Hyper-threading Technology to enhance CPU performance. The options are **Enabled** and Disabled.

**Active Processor Cores**

This feature determines how many CPU cores will be activated for each CPU. When all is selected, all cores in the CPU will be activated. (Please refer to Intel's website for more information.) The options are **All** and 1, 2, and 3.

**Intel® Virtualization Technology**

Select Enable to use Intel Virtualization Technology so that I/O device assignments will be reported directly to the VMM (Virtual Memory Management) through the DMAR ACPI Tables. This feature offers fully-protected I/O resource-sharing across the Intel platforms, providing the user with greater reliability, security and availability in networking and data-sharing. The settings are **Enabled** and Disabled.

**Hardware Prefetcher (Available when supported by the CPU)**

If set to Enabled, the hardware prefetcher will prefetch streams of data and instructions from the main memory to the L2 cache to improve CPU performance. The options are Disabled and **Enabled**.

**Adjacent Cache Line Prefetch (Available when supported by the CPU)**

The CPU prefetches the cache line for 64 bytes if this feature is set to Disabled. The CPU prefetches both cache lines for 128 bytes as comprised if this feature is set to **Enabled**.

**CPU AES**

Select Enabled to enable Intel CPU Advanced Encryption Standard (AES) Instructions for CPU to enhance data integrity. The options are **Enabled** and Disabled.

**Boot Performance Mode**

This feature allows the user to select the performance state that the BIOS will set before the operating system handoff. The options are Power Saving, **Max Non-Turbo Performance** and Turbo Performance.

**HardWare P-States (HWP)**

Use this feature to enable or disable hardware P-States support. The options are **Disabled** and Enabled.

**Intel® SpeedStep™**

Intel SpeedStep Technology allows the system to automatically adjust processor voltage and core frequency to reduce power consumption and heat dissipation. The options are Disabled and **Enabled**.

### **Turbo Mode**

Select Enabled for processor cores to run faster than the frequency specified by the manufacturer. The options are Disabled and **Enabled**.

### **Package Power Limit MSR Lock**

Select Enabled to lock the package power limit for the model specific registers. The options are **Disabled** and Enabled.

### **Power Limit 1 Override**

Select Enabled to support average power limit (PL1) override. The default setting is **Disabled**.

### **Power Limit 2 Override**

Select Enabled to support rapid power limit (PL2) override. The default setting is **Enabled**.

### **Power Limit 2**

Use this item to configure the value for Power Limit 2. The value is in milli watts and the step size is 125mW. Use the number keys on your keyboard to enter the value. Enter 0 to use the manufacture default setting. If the value is 0, the BIOS will set PL2 as 1.25\* TDP.

### **1-Core Ratio Limit Override**

This increases (multiplies) 1 clock speed in the CPU core in relation to the bus speed when one CPU core is active. Press "+" or "-" on your keyboard to change the value. Enter 0 to use the manufacture default setting.

### **2-Core Ratio Limit Override**

This increases (multiplies) 2 clock speeds in the CPU core in relation to the bus speed when two CPU cores are active. Press "+" or "-" on your keyboard to change the value. Enter 0 to use the manufacture default setting.

### **3-Core Ratio Limit Override**

This increases (multiplies) 3 clock speeds in the CPU core in relation to the bus speed when three CPU cores are active. Press "+" or "-" on your keyboard to change the value. Enter 0 to use the manufacture default setting.

### **4-Core Ratio Limit Override**

This increases (multiplies) 4 clock speeds in the CPU core in relation to the bus speed when three CPU cores are active. Press "+" or "-" on your keyboard to change the value. Enter 0 to use the manufacture default setting.

### **CPU C-States**

Use this feature to enable the C-State of the CPU. The options are Disabled and **Enabled**.

### **Enhanced C-States**

Use this feature to enable the enhanced C-State of the CPU. The options are Disabled and **Enabled**.

### **C-State Auto Demotion**

Use this feature to prevent unnecessary excursions into the C-states to improve latency. The options are Disabled, C1, C3, and **C1 and C3**.

### **C-State Un-Demotion**

This feature allows the user to enable or disable the un-demotion of C-State. The options are Disabled, C1, C3, and **C1 and C3**.

### **Package C-State Demotion**

Use this feature to enable or disable the Package C-State demotion. The options are **Disabled**, C1, C3, and C1 and C3.

### **Package C-State Un-Demotion**

Use this feature to enable or disable the Package C-State un-demotion. The options are **Disabled**, C1, C3, and C1 and C3.

### **C-State Pre-Wake**

This feature allows the user to enable or disable the C-State Pre-Wake. The options are Disabled and **Enabled**.

### **Package C-State Limit**

Use this feature to set the Package C-State limit. The options are C0/C1, C2, C3, C6, C7, C7s, C8, and **AUTO**.

## **► CPU Thermal Configuration**

### **CPU DTS**

Select Enabled for the ACPI thermal management to use the DTS SMM mechanism to obtain CPU temperature values. Select Disabled for EC to report the CPU temperature values. The options are **Disabled** and Enabled.

### **ACPI 3.0 T-States**

Select Enabled to support CPU throttling by the operating system to reduce power consumption. The options are Enabled and **Disabled**.

## **► Chipset Configuration**

**Caution:** Setting the wrong values in the following features may cause the system to malfunction.

## **► System Agent (SA) Configuration**

The following System Agent information will display:

- System Agent Bridge Name

- SA PCIe Code Version
- VT-d

### **VT-d**

Select Enabled to enable Intel Virtualization Technology support for Direct I/O VT-d by reporting the I/O device assignments to VMM through the DMAR ACPI Tables. This feature offers fully-protected I/O resource-sharing across the Intel platforms, providing the user with greater reliability, security and availability in networking and data-sharing. The options are **Enabled** and Disabled.

### **SW Guard Extensions (SGX)**

Use this feature to enable or disable the Intel Software Guard Extensions (SGX). SGX is a set of CPU instructions that increases software security. The options are Disabled, **Enabled**, and Software Controlled.

### **Select Owner EPOCH Input Type**

Use this feature to select an Intel Software Guard Extensions (SGX) EPOCH mode. Each mode has different values, which can be entered manually. The options are **No Change in Owner EPOCHs**, Change to New Random Owner EPOCHs, and Manual User Defined Owner EPOCHs.

### **PRMRR Size**

The BIOS must reserve a contiguous region of Processor Reserved Memory (PRM) in the Processor Reserved Memory Range Register (PRMRR). This feature appears if SW Guard Extensions is set to Enabled. The options are **Auto**, 32MB, 64MB, and 128MB.

## **► Graphics Configuration**

### **Internal Graphics**

Select Auto to keep an internal graphics device installed on an expansion slot supported by the CPU to be automatically enabled. The options are **Auto**, Disabled, and Enabled.

### **GTT Size**

Use this feature to set the memory size to be used by the graphics translation table (GTT). The options are 2MB, 4MB, and **8MB**.

### **Aperture Size**

Use this feature to set the Aperture size, which is the size of system memory reserved by the BIOS for graphics device use. The options are 128MB, **256MB**, 512 MB, 1024MB, 2048MB, and 4096MB.

**DVMT Pre-Allocated**

Dynamic Video Memory Technology (DVMT) allows dynamic allocation of system memory to be used for video devices to ensure best use of available system memory based on the DVMT 5.0 platform. The options are **32M**, 64M, 96M, 128M, 160M, 192M, 224M, 256M, 288M, 320M, 352M, 384M, 416M, 448M, 480M, 512M, 1024M, 1536M, 2048M, 4M, 8M, 12M, 20M, 24M, 28M, 32M/F7, 36M, 40M, 44M, 48M, 52M, 56M, and 60M. .

**DVMT Total IGFX Memory**

Use this feature to set the total memory size to be used by internal graphics devices based on the DVMT 5.0 platform. The options are 128MB, **256MB**, and MAX.

**IGFX (Graphics) Low Power Mode**

Select Enabled to use the low power mode for internal graphics devices installed in a small form factor (SFF) computer. The options are **Enabled** and Disabled.

**PM Support**

Use this item to enable the IGFX Power Management function. The options are **Enabled** and Disabled.

**PAVP Enable**

Use this feature to enable or disable the protected audio video path (PAVP). The options are Disabled or **Enabled**.

**► DMI/OPI Configuration**

The following DMI information will display:

- DMI

**DMI VC1 Control**

Use this feature to enable or disable DMI Virtual Channel 1. The options are Enabled and **Disabled**.

**DMI VCm Control**

Use this feature to enable or disable the DMI Virtual Channel map. The options are **Enabled** and Disabled.

**CPU DMI Link ASPM Control**

Use this feature to set the ASPM (Active State Power Management) state on the SA (System Agent) side of the DMI Link. The options are Disabled and **L1**.

**DMI Extended Sync Control**

Use this feature to enable or disable the DMI extended synchronization. The options are Enabled and **Disabled**.

### **DMI De-Emphasis Control**

Use this feature to configure the De-emphasis control on DMI. The options are -6dB and -3.5dB.

## **► PEG Port Configuration**

### **PEG 0:1:0**

#### **PEG0 Enable Root Port**

Use this feature to enable or disable the PCI Express Graphics (PEG) device in the port specified by the user. The options are Disabled, Enabled, and **Auto**.

#### **PEG0 Max Link Speed**

Use this item to configure the link speed of a PCI-E port specified by the user. The options are **Auto**, Gen1, Gen2, and Gen3.

#### **PEG0 Max Payload Size**

Select Auto for the system BIOS to automatically set the maximum payload value for a PCI-E device to enhance system performance. The options are **Auto**, 128 TLP and 256 TLP.

#### **PEG0 Slot Power Limit Value**

Use this feature to set the upper limit on the power supplied by the PCIE slot. Press "+" or "-" on your keyboard to change this value. The default setting is **75**.

#### **PEG0 Slot Power Limit Scale**

Use this feature to select the scale used for the slot power limit value. The options are **1.0x**, 0.1x, 0.01x, and 0.001x.

### **Program PCIe ASPM After OPROM**

PCIe ASPM, the Active State Power Management for PCI-Express slots, is a power management protocol used to manage power consumption of serial-link devices installed on PCI-Exp slots during a prolonged off-peak time. If this item is set to Enabled, PCI-E ASMP will be programmed after OPROM. If this item is set to Disabled, the PCI-E ASPM will be programmed before OPROM. The options are **Disabled** and Enabled.

## **► Memory Configuration**

The following memory information will display:

- Memory RC Version
- Memory Frequency
- Total Memory
- VDD

- DIMMA1
- DIMMA2
- DIMMB1
- DIMMB2
- Memory Timings (tCL-tRCD-tRP-tRAS)

### **Maximum Memory Frequency**

Use this feature to set the maximum memory frequency for onboard memory modules. The options are **Auto**, 1067, 1200, 1333, 1400, 1600, 1800, 1867, 2000, 2133, 2200, and 2400.

### **Max TOLUD**

This feature sets the maximum TOLUD value, which specifies the "Top of Low Usable DRAM" memory space to be used by internal graphics devices, GTT Stolen Memory, and TSEG, respectively, if these devices are enabled. The options are **Dynamic**, 1 GB, 1.25 GB, 1.5 GB, 1.75 GB, 2 GB, 2.25 GB, 2.5 GB, 2.75 GB, 3 GB, 3.25 GB, and 3.5 GB.

### **Energy Performance Gain**

Use this feature to enable or disable the energy performance gain. The options are **Disabled** and **Enabled**.

### **Memory Scrambler**

Select **Enabled** to enable memory scrambler support. The options are **Disabled** and **Enabled**.

### **Fast Boot**

Use this feature to enable or disable fast path through the memory reference code. The options are **Enabled** and **Disabled**.

### **REFRESH\_2X\_MODE**

Use this feature to select the refresh mode. The options are **Disabled**, 1-Enabled for WARM or HOT, and 2-Enabled HOT only.

### **Closed Loop Thermal Management**

Use this feature to monitor the power consumption and temperature of the system to predict a thermal trend. The options are **Disabled** and **Enabled**.

## **► PCH-IO Configuration**

The following PCH-IO information will display:

- Intel PCH RC Version

- Intel PCH SKU Name
- Intel PCH Rev ID

### **Port 61h bit-4 Emulation**

Select Enabled to enable the emulation of Port 61h bit-4 toggling in SMM (System Management Mode). The options are Disabled and **Enabled**.

### **PCIe PLL SSC**

Enable this feature to reduce EMI interference by down spreading clock 0.5%. Disable this feature to centralize the clock without spreading. The options are **Disabled** and Enabled.

## **► SATA Configuration**

When this submenu is selected, the AMI BIOS automatically detects the presence of the SATA devices that are supported by the Intel PCH chip and displays the following items:

### **SATA Controller(s)**

This item enables or disables the onboard SATA controller supported by the Intel PCH chip. The options are **Enabled** and Disabled.

### **SATA Mode Selection**

Use this item to select the mode for the installed SATA drives. The options are **AHCI** and RAID.

### **SATA Frozen**

Use this item to enable the HDD Security Frozen Mode. The options are Enabled and **Disabled**.

***\*If the item "SATA Mode Selection" is set to RAID, the following items will display:***

#### **SATA RAID Option ROM/UEFI Driver**

Select UEFI to load the EFI driver for system boot. Select Legacy to load a legacy driver for system boot. The options are **Legacy ROM** and UEFI Driver.

#### **SATA Port 0 ~ Port 5**

This item displays the information detected on the installed SATA drive on the particular SATA port.

- Model number of drive and capacity
- Software Preserve Support

#### **Port 0 ~ Port 5 Hot Plug**

This feature designates the SATA port specified for hot plugging. Set this item to Enabled for hot-plugging support, which will allow the user to replace a SATA disk drive without shutting down the system. The options are **Disabled** and Enabled.

**Port 0 ~ Port 5 Spin Up Device**

On an edge detect from 0 to 1, set this item to allow the PCH to initialize the device. The options are Enabled and **Disabled**.

**Port 0 ~ Port 5 SATA Device Type**

Use this item to specify if the SATA port specified by the user should be connected to a Solid State drive or a Hard Disk Drive. The options are **Hard Disk Drive** and Solid State Drive.

**►PCIe/PCI/PnP Configuration**

The following information will display:

- PCI Bus Driver Version
- PCI Devices Common Settings:

**PCI PERR/SERR Support**

Select Enabled to allow a PCI device to generate a PERR/SERR number for a PCI Bus Signal Error Event. The options are Enabled and **Disabled**.

**Above 4G Decoding (Available if the system supports 64-bit PCI decoding)**

Select Enabled to decode a PCI device that supports 64-bit in the space above 4G Address. The options are Enabled and **Disabled**.

**SR-IOV Support**

Use this feature to enable or disable Single Root IO Virtualization Support. The options are **Disabled** and Enabled.

**CPU MICRO-LP PCI-E 3.0 X8 OPROM**

Use this feature to select which firmware type to be loaded for the add-on card in this slot. The options are Disabled, **Legacy**, and EFI.

**Onboard Video Option ROM**

Use this item to select the Onboard Video Option ROM type. The options are Disabled, **Legacy**, and EFI.

**Network Stack**

Select Enabled to enable PXE (Preboot Execution Environment) or UEFI (Unified Extensible Firmware Interface) for network stack support. The options are **Enabled** and Disabled.

**IPv4 PXE Support**

Select Enabled to enable IPv4 PXE boot support. The options are **Enabled** and Disabled.

**IPv6 PXE Support**

Select Enabled to enable IPv6 PXE boot support. The options are Enabled and **Disabled**.

### **PXE boot wait time**

Use this option to specify the wait time to press the ESC key to abort the PXE boot. Press "+" or "-" on your keyboard to change the value. The default setting is **0**.

### **Media detect count**

Use this option to specify the number of times media will be checked. Press "+" or "-" on your keyboard to change the value. The default setting is **1**.

## **► Super IO Configuration**

The following Super IO information will display:

- Super IO Chip AST 2400

### **Super IO Chip Logical Device(s) Configuration**

#### **► Serial Port 1 Configuration**

This submenu allows the user the configure settings of Serial Port 1.

#### **Serial Port 1**

Select Enabled to enable the selected onboard serial port. The options are **Enabled** and Disabled.

#### **Logical Device Settings**

This item displays the status of a serial part specified by the user.

#### **Serial Port 1 Change Settings**

This feature specifies the base I/O port address and the Interrupt Request address of a serial port specified by the user. Select Auto to allow the BIOS to automatically assign the base I/O and IRQ address.

The options for Serial Port 1 are **Auto**, (IO=3F8h; IRQ=4;), (IO=3F8h; IRQ=3, 4, 5, 6, 7, 9, 10, 11, 12;), (IO=2F8h; IRQ=3, 4, 5, 6, 7, 9, 10, 11, 12;), (IO=3E8h; IRQ=3, 4, 5, 6, 7, 9, 10, 11, 12;), and (IO=2E8h; IRQ=3, 4, 5, 6, 7, 9, 10, 11, 12;).

#### **► Serial Port 2 (SOL)**

This submenu allows the user the configure settings of Serial Port 2.

#### **Serial Port 2 (SOL)**

Select Enabled to enable the selected onboard serial port. The options are **Enabled** and Disabled.

#### **Logical Device Settings**

This item displays the status of a serial part specified by the user.

### Serial Port 2 (SOL) Change Settings

This feature specifies the base I/O port address and the Interrupt Request address of a serial port specified by the user. Select Auto to allow the BIOS to automatically assign the base I/O and IRQ address.

The options for Serial Port 2 are **Auto**, (IO=2F8h; IRQ=3;), (IO=3F8h; IRQ=3, 4, 5, 6, 7, 9, 10, 11, 12;), (IO=2F8h; IRQ=3, 4, 5, 6, 7, 9, 10, 11, 12;), (IO=3E8h; IRQ=3, 4, 5, 6, 7, 9, 10, 11, 12;), and (IO=2E8h; IRQ=3, 4, 5, 6, 7, 9, 10, 11, 12;).

### ► Intel Server Platform Services

The following Intel Server Platform Services information will display:

- ME BIOS Interface Version
- SPS Version
- ME FW Status Value
- ME FW State
- ME FW Operation State
- ME FW Error Code
- ME NM FW Status Value
- BIOS Booting Mode
- Cores Disabled
- ME FW SKU Information
- End-of-POST Status

### ► Serial Port Console Redirection

#### COM1 Console Redirection

#### Console Redirection

Select Enabled to enable console redirection support for a serial port specified by the user. The options are Enabled and **Disabled**.

***\*If the item above set to Enabled, the following items will become available for user's configuration:***

## ►COM1 Console Redirection Settings

This feature allows the user to specify how the host computer will exchange data with the client computer, which is the remote computer used by the user.

### COM1 Terminal Type

This feature allows the user to select the target terminal emulation type for Console Redirection. Select VT100 to use the ASCII Character set. Select VT100+ to add color and function key support. Select ANSI to use the Extended ASCII Character Set. Select VT-UTF8 to use UTF8 encoding to map Unicode characters into one or more bytes. The options are VT100, **VT100+**, VT-UTF8, and ANSI.

### COM1 Bits Per second

Use this feature to set the transmission speed for a serial port used in Console Redirection. Make sure that the same speed is used in the host computer and the client computer. A lower transmission speed may be required for long and busy lines. The options are 9600, 19200, 38400, 57600 and **115200** (bits per second).

### COM1 Data Bits

Use this feature to set the data transmission size for Console Redirection. The options are 7 Bits and **8 Bits**.

### COM1 Parity

A parity bit can be sent along with regular data bits to detect data transmission errors. Select Even if the parity bit is set to 0, and the number of 1's in data bits is even. Select Odd if the parity bit is set to 0, and the number of 1's in data bits is odd. Select None if you do not want to send a parity bit with your data bits in transmission. Select Mark to add a mark as a parity bit to be sent along with the data bits. Select Space to add a Space as a parity bit to be sent with your data bits. The options are **None**, Even, Odd, Mark, and Space.

### COM1 Stop Bits

A stop bit indicates the end of a serial data packet. Select 1 Stop Bit for standard serial data communication. Select 2 Stop Bits if slower devices are used. The options are **1** and 2.

### COM1 Flow Control

Use this feature to set the flow control for Console Redirection to prevent data loss caused by buffer overflow. Send a "Stop" signal to stop sending data when the receiving buffer is full. Send a "Start" signal to start sending data when the receiving buffer is empty. The options are **None** and Hardware RTS/CTS.

### COM1 VT-UTF8 Combo Key Support

Select Enabled to enable VT-UTF8 Combination Key support for ANSI/VT100 terminals. The options are Disabled and **Enabled**.

**COM1 Recorder Mode**

Select Enabled to capture the data displayed on a terminal and send it as text messages to a remote server. The options are **Disabled** and Enabled.

**COM1 Resolution 100x31**

Select Enabled for extended-terminal resolution support. The options are Disabled and **Enabled**.

**COM1 Legacy OS Redirection Resolution**

Use this feature to select the number of rows and columns used in Console Redirection for legacy OS support. The options are 80x24 and **80x25**.

**COM1 Putty KeyPad**

This feature selects the settings for Function Keys and KeyPad used for Putty, which is a terminal emulator designed for the Windows OS. The options are **VT100**, LINUX, XTERMR6, SC0, ESCN, and VT400.

**COM1 Redirection After BIOS POST**

Use this feature to enable or disable legacy console redirection after BIOS POST. When set to Bootloader, legacy console redirection is disabled before booting the OS. When set to Always Enable, legacy console redirection remains enabled when booting the OS. The options are **Always Enable** and Bootloader.

**SOL Console Redirection**

Select Enabled to use the SOL port for Console Redirection. The options are **Enabled** and Disabled.

***\*If the item above set to Enabled, the following items will become available for user's configuration:***

**► SOL Console Redirection Settings**

Use this feature to specify how the host computer will exchange data with the client computer, which is the remote computer used by the user.

**SOL Terminal Type**

Use this feature to select the target terminal emulation type for Console Redirection. Select VT100 to use the ASCII Character set. Select VT100+ to add color and function key support. Select ANSI to use the Extended ASCII Character Set. Select VT-UTF8 to use UTF8 encoding to map Unicode characters into one or more bytes. The options are ANSI, VT100, **VT100+**, and VT-UTF8.

**SOL Bits Per second**

Use this feature to set the transmission speed for a serial port used in Console Redirection. Make sure that the same speed is used in the host computer and the client computer. A lower

transmission speed may be required for long and busy lines. The options are 9600, 19200, 38400, 57600 and **115200** (bits per second).

#### **SOL Data Bits**

Use this feature to set the data transmission size for Console Redirection. The options are 7 Bits and **8 Bits**.

#### **SOL Parity**

A parity bit can be sent along with regular data bits to detect data transmission errors. Select Even if the parity bit is set to 0, and the number of 1's in data bits is even. Select Odd if the parity bit is set to 0, and the number of 1's in data bits is odd. Select None if you do not want to send a parity bit with your data bits in transmission. Select Mark to add a mark as a parity bit to be sent along with the data bits. Select Space to add a Space as a parity bit to be sent with your data bits. The options are **None**, Even, Odd, Mark and Space.

#### **SOL Stop Bits**

A stop bit indicates the end of a serial data packet. Select 1 Stop Bit for standard serial data communication. Select 2 Stop Bits if slower devices are used. The options are **1** and 2.

#### **SOL Flow Control**

Use this feature to set the flow control for Console Redirection to prevent data loss caused by buffer overflow. Send a "Stop" signal to stop sending data when the receiving buffer is full. Send a "Start" signal to start sending data when the receiving buffer is empty. The options are **None** and Hardware RTS/CTS.

#### **SOL VT-UTF8 Combo Key Support**

Select Enabled to enable VT-UTF8 Combination Key support for ANSI/VT100 terminals. The options are Disabled and **Enabled**.

#### **SOL Recorder Mode**

Select Enabled to capture the data displayed on a terminal and send it as text messages to a remote server. The options are **Disabled** and Enabled.

#### **SOL Resolution 100x31**

Select Enabled for extended-terminal resolution support. The options are Disabled and **Enabled**.

#### **SOL Legacy OS Redirection Resolution**

Use this feature to select the number of rows and columns used in Console Redirection for legacy OS support. The options are 80x24 and **80x25**.

#### **SOL Putty KeyPad**

This feature selects Function Keys and KeyPad settings for Putty, which is a terminal emulator designed for the Windows OS. The options are **VT100**, LINUX, XTERMR6, SCO, ESCN, and VT400.

### **SOL Redirection After BIOS POST**

Use this feature to enable or disable legacy Console Redirection after BIOS POST. When set to Bootloader, legacy Console Redirection is disabled before booting the OS. When set to Always Enable, legacy Console Redirection remains enabled when booting the OS. The options are **Always Enable** and Bootloader.

### **EMS (Emergency Management Services) Console Redirection**

Select Enabled to use a COM port selected by the user for EMS Console Redirection. The options are Enabled and **Disabled**.

***\*If the item above set to Enabled, the following items will become available for user's configuration:***

### **► EMS Console Redirection Settings**

This feature allows the user to specify how the host computer will exchange data with the client computer, which is the remote computer used by the user.

#### **Out-of-Band Mgmt Port**

The feature selects a serial port in a client server to be used by the Microsoft Windows Emergency Management Services (EMS) to communicate with a remote host server. The options are **COM1** and SOL/COM2.

#### **Terminal Type**

Use this feature to select the target terminal emulation type for Console Redirection. Select VT100 to use the ASCII character set. Select VT100+ to add color and function key support. Select ANSI to use the extended ASCII character set. Select VT-UTF8 to use UTF8 encoding to map Unicode characters into one or more bytes. The options are VT100, VT100+, **VT-UTF8**, and ANSI.

#### **Bits Per Second**

This item sets the transmission speed for a serial port used in Console Redirection. Make sure that the same speed is used in the host computer and the client computer. A lower transmission speed may be required for long and busy lines. The options are 9600, 19200, 57600, and **115200** (bits per second).

#### **Flow Control**

Use this item to set the flow control for Console Redirection to prevent data loss caused by buffer overflow. Send a "Stop" signal to stop sending data when the receiving buffer is full. Send a "Start" signal to start sending data when the receiving buffer is empty. The options are **None**, Hardware RTS/CTS, and Software Xon/Xoff.

#### **Data Bits**

#### **Parity**

#### **Stop Bits**

## ►ACPI Settings

### High Precision Event Timer

Select Enabled to activate the High Performance Event Timer (HPET) that produces periodic interrupts at a much higher frequency than a Real-time Clock (RTC) does in synchronizing multimedia streams, providing smooth playback and reducing the dependency on other timestamp calculation devices, such as an x86 RDTSC Instruction embedded in the CPU. The High Performance Event Timer is used to replace the 8254 Programmable Interval Timer. The options are Disabled and **Enabled**.

### WHEA Support

Select Enabled to support the Windows Hardware Error Architecture (WHEA) platform and provide a common infrastructure for the system to handle hardware errors within the Windows OS environment to reduce system crashes and to enhance system recovery and health monitoring. The options are Disabled and **Enabled**.

## ►Trusted Computing Configuration

### Security Device Support

If this feature and the TPM jumper on the motherboard are both set to Enabled, onboard security devices will be enabled for TPM (Trusted Platform Module) support to enhance data integrity and network security. Please reboot the system for a change on this setting to take effect. The options are Disabled and **Enabled**.

***\*If the item above set to Enabled, the following items will become available for user's configuration:***

The following Platform Configuration Register information will display:

#### **Active PCR banks**

#### **Available PCR banks**

### **SHA-1 PCR Bank**

Use this item to disable or enable the SHA-1 Platform Configuration Register (PCR) bank for the installed TPM device. The options are Disabled and **Enabled**.

### **SHA256 PCR Bank**

Use this item to disable or enable the SHA256 Platform Configuration Register (PCR) bank for the installed TPM device. The options are Disabled and **Enabled**.

### **TPM State**

This feature changes the TPM State. The options are **Disabled** and Enabled. Note: The system will restart to change the TPM State.

### **Pending TPM operation**

Use this item to schedule a TPM-related operation to be performed by a security device for system data integrity. Your system will reboot to carry out a pending TPM operation. The options are **None** and TPM Clear.

### **Platform Hierarchy**

Use this item to disable or enable platform hierarchy for platform protection. The options are Disabled and **Enabled**.

### **Storage Hierarchy**

Use this item to disable or enable storage hierarchy for cryptographic protection. The options are Disabled and **Enabled**.

### **Endorsement Hierarchy**

Use this item to disable or enable endorsement hierarchy for privacy control. The options are Disabled and **Enabled**.

### **Hash Policy**

Use this item to select which hash policy to use. SHA-1 is the most secured, but it may not be supported by all operating systems. The options are **Sha-1** and Sha256.

### **Device Select**

Use this feature to select the TPM version. TPM 1.2 will restrict support to TPM 1.2 devices. TPM 2.0 will restrict support for TPM 2.0 devices. Select Auto to enable support for both versions. The default setting is **Auto**.

The following are informational status messages that indicate the current TPM State:

**TPM Enabled Status**

**TPM Active Status**

**TPM Owner Status**

### **TXT Support**

Intel TXT (Trusted Execution Technology) helps protect against software-based attacks and ensures protection, confidentiality and integrity of data stored or created on the system. Use this feature to enable or disable TXT Support. The options are **Disabled** and Enabled.

## **► iSCSI Configuration**

### **iSCSI Initiator Name**

This feature allows the user to enter the unique name of the iSCSI Initiator in IQN format. Once the name of the iSCSI Initiator is entered into the system, configure the proper settings for the following items.

- ▶ Add an Attempt
- ▶ Delete Attempts
- ▶ Change Attempt order

## 6.4 Event Logs

Use this feature to configure Event Log settings.

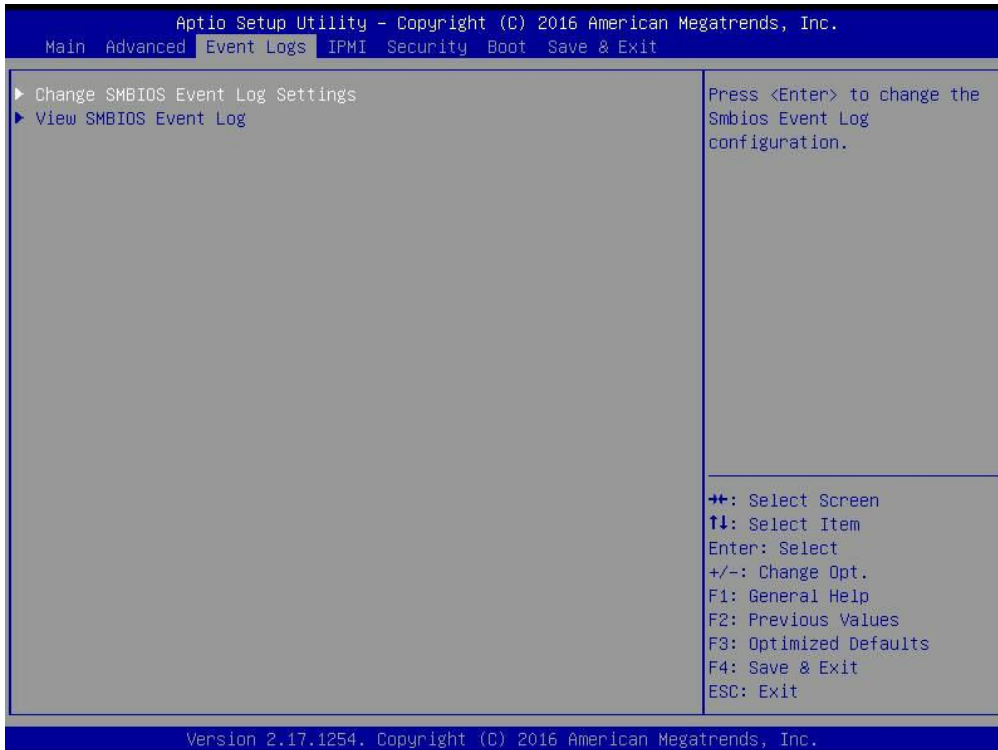

### ▶ Change SMBIOS Event Log Settings

#### Enabling/Disabling Options

##### SMBIOS Event Log

Change this item to enable or disable all features of the SMBIOS Event Logging during system boot. The options are **Enabled** and Disabled.

#### Erasing Settings

##### Erase Event Log

If No is selected, data stored in the event log will not be erased. Select Yes, Next Reset, data in the event log will be erased upon next system reboot. Select Yes, Every Reset, data in the event log will be erased upon every system reboot. The options are **No**, Yes, Next reset, and Yes, Every reset.

**When Log is Full**

Select Erase Immediately for all messages to be automatically erased from the event log when the event log memory is full. The options are **Do Nothing** and Erase Immediately.

**SMBIOS Event Long Standard Settings****Log System Boot Event**

This option toggles the System Boot Event logging to enabled or disabled. The options are **Disabled** and Enabled.

**MECI**

The Multiple Event Count Increment (MECI) counter counts the number of occurrences that a duplicate event must happen before the MECI counter is incremented. This is a numeric value. The default value is **1**.

**METW**

The Multiple Event Time Window (METW) defines number of minutes must pass between duplicate log events before MECI is incremented. This is in minutes, from 0 to 99. The default value is **60**.

**Note:** After making changes on a setting, be sure to reboot the system for the changes to take effect.

**►View SMBIOS Event Log**

This section displays the contents of the SMBIOS Event Log.

## 6.5 IPMI

Use this feature to configure Intelligent Platform Management Interface (IPMI) settings.



### BMC Firmware Revision

This item indicates the IPMI firmware revision used in your system.

### IPMI Status (Baseboard Management Controller)

This item indicates the status of the IPMI firmware installed in your system.

## ► System Event Log

### Enabling/Disabling Options

#### SEL Components

Select Enabled for all system event logging at bootup. The options are **Enabled** and Disabled.

#### Erasing Settings

##### Erase SEL

Select Yes, On next reset to erase all system event logs upon next system reboot. Select Yes, On every reset to erase all system event logs upon each system reboot. Select No to keep all system event logs after each system reboot. The options are **No**, Yes, On next reset, and Yes, On every reset.

### **When SEL is Full**

This feature allows the user to decide what the BIOS should do when the system event log is full. Select Erase Immediately to erase all events in the log when the system event log is full. The options are **Do Nothing** and Erase Immediately.

**Note:** After making changes on a setting, be sure to reboot the system for the changes to take effect.

## **►BMC Network Configuration**

### **BMC Network Configuration**

#### **IPMI LAN Selection**

This item displays the IPMI LAN setting. The default setting is **Failover**.

#### **IPMI Network Link Status**

This item displays the IPMI Network Link status. The default setting is **Shared LAN**.

#### **Update IPMI LAN Configuration**

Select Yes for the BIOS to implement all IP/MAC address changes at the next system boot. The options are **No** and Yes

#### **Configuration Address Source**

This feature allows the user to select the source of the IP address for this computer. If Static is selected, you will need to know the IP address of this computer and enter it to the system manually in the field. If DHCP is selected, the BIOS will search for a DHCP (Dynamic Host Configuration Protocol) server in the network that is attached to and request the next available IP address for this computer. The options are **DHCP** and Static. The following items are assigned IP addresses automatically if DHCP is selected.

#### **Current Configuration Address Source**

This item displays the current configuration address for this computer.

#### **Station IP Address**

This item displays the Station IP address for this computer. This should be in decimal and in dotted quad form (i.e., 192.168.10.253).

#### **Subnet Mask**

This item displays the sub-network that this computer belongs to. The value of each three-digit number separated by dots should not exceed 255.

#### **Station MAC Address**

This item displays the Station MAC address for this computer. Mac addresses are 6 two-digit hexadecimal numbers.

## Gateway IP Address

This item displays the Gateway IP address for this computer. This should be in decimal and in dotted quad form (i.e., 172.31.0.1).

## VLAN

Use this item to enable or disable the IPMI VLAN function. The options are **Disable** and **Enable**.

## 6.6 Security

This menu allows the user to configure the following security settings for the system.

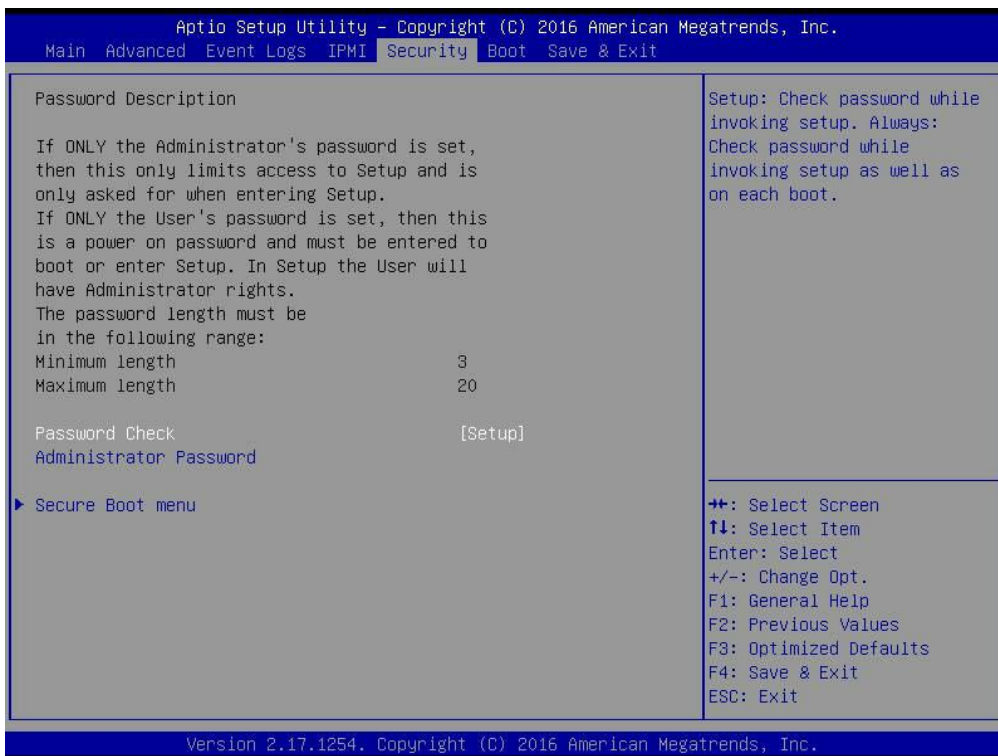

### Password Check

Select Setup for the system to check for a password at Setup. Select Always for the system to check for a password at bootup or upon entering the BIOS Setup utility. The options are **Setup** and **Always**.

### Administrator Password

Press Enter to create a new, or change an existing Administrator password.

## ► Secure Boot Menu

This section displays the contents of the following secure boot features:

- System Mode
- Secure Boot
- Vendor Keys

### Secure Boot

Use this item to enable secure boot. The options are **Disabled** and Enabled.

### Secure Boot Mode

Use this item to select the secure boot mode. The options are Standard and **Custom**.

### CSM Support

Select Enabled to support the EFI Compatibility Support Module (CSM), which provides compatibility support for traditional legacy BIOS for system boot. The options are **Enabled** and Disabled.

## ► Key Management

This submenu allows the user to configure the following Key Management settings.

### Provision Factory Default Keys

Select Enabled to install the default Secure-Boot keys set by the manufacturer. The options are **Disabled** and Enabled.

### ► Enroll All Factory Default Keys

Select Yes to install all default secure keys set by the manufacturer. The options are **Yes** and No.

### Save All Secure Boot Variables

This feature allows the user to decide if all secure boot variables should be saved.

### ► Platform Key (PK)

This feature allows the user to configure the settings of the platform keys.

### Set New Key

Select Yes to load the new platform keys (PK) from the manufacturer's defaults. Select No to load the platform keys from a file. The options are **Yes** and No.

▶ **Key Exchange Key**

**Set New Key**

Select Yes to load the KEK from the manufacturer's defaults. Select No to load the KEK from a file. The options are Yes and No.

**Append Key**

Select Yes to add the KEK from the manufacturer's defaults list to the existing KEK. Select No to load the KEK from a file. The options are Yes and No.

▶ **Authorized Signatures**

**Set New Key**

Select Yes to load the database from the manufacturer's defaults. Select No to load the DB from a file. The options are Yes and No.

**Append Key**

Select Yes to add the database from the manufacturer's defaults to the existing DB. Select No to load the DB from a file. The options are Yes and No.

▶ **Forbidden Signatures**

**Set New Key**

Select Yes to load the DBX from the manufacturer's defaults. Select No to load the DBX from a file. The options are Yes and No.

**Append Key**

Select Yes to add the DBX from the manufacturer's defaults to the existing DBX. Select No to load the DBX from a file. The options are Yes and No.

▶ **Authorized TimeStamps**

**Set New Key**

Select Yes to load the DBT from the manufacturer's defaults. Select No to load the DBT from a file. The options are Yes and No.

**Append Key**

Select Yes to add the DBT from the manufacturer's defaults list to the existing DBT. Select No to load the DBT from a file. The options are Yes and No.

## 6.7 Boot

Use this feature to configure Boot Settings.

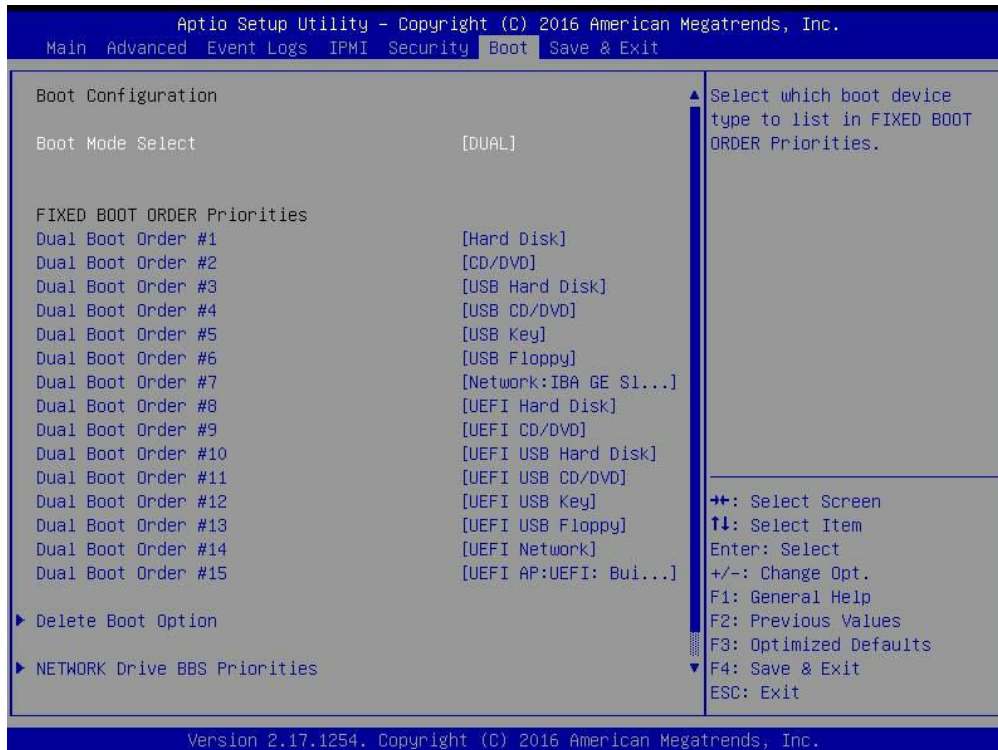

### Boot Mode Select

Use this item to select the type of device that the system is going to boot from. The options are Legacy, UEFI, and **Dual**. The default setting is Dual.

### Fixed Boot Order Priorities

This option prioritizes the order of bootable devices that the system to boot from. Press <Enter> on each entry from top to bottom to select devices.

***\*If the item above set to Legacy, UEFI/Dual the following items will be displayed:***

- Legacy/UEFI/Dual/Boot Option #1
- Legacy/UEFI/Dual/Boot Option #2
- Legacy/UEFI/Dual/Boot Option #3
- Legacy/UEFI/Dual/Boot Option #4
- Legacy/UEFI/Dual/Boot Option #5
- Legacy/UEFI/Dual/Boot Option #6
- Legacy/UEFI/Dual/Boot Option #7
- Legacy/UEFI/Dual/Boot Option #8

- Legacy/UEFI/Dual/Boot Option #9
- Legacy/UEFI/Dual/Boot Option #10
- Legacy/UEFI/Dual/Boot Option #11
- Legacy/UEFI/Dual/Boot Option #12
- Legacy/UEFI/Dual/Boot Option #13
- Legacy/UEFI/Dual/Boot Option #14
- Legacy/UEFI/Dual/Boot Option #15

► **Delete Boot Option**

Use this feature to remove a pre-defined boot device from which the system will boot during startup.

The settings are [any pre-defined boot device].

► **Hard Disk Drive BBS Priorities**

This feature allows the user to specify which hard disk drive devices are boot devices.

- Legacy Boot Order #1

► **NETWORK Drive BBS Priorities**

This feature allows the user to specify which UEFI network drive devices are boot devices.

- Legacy Boot Order #1
- Legacy Boot Order #2

► **UEFI Application Boot Priorities**

This feature allows the user to specify which UEFI devices are boot devices.

- UEFI Boot Order #1

## 6.8 Save & Exit

Select the Exit tab from the BIOS setup utility screen to enter the Exit BIOS Setup screen.

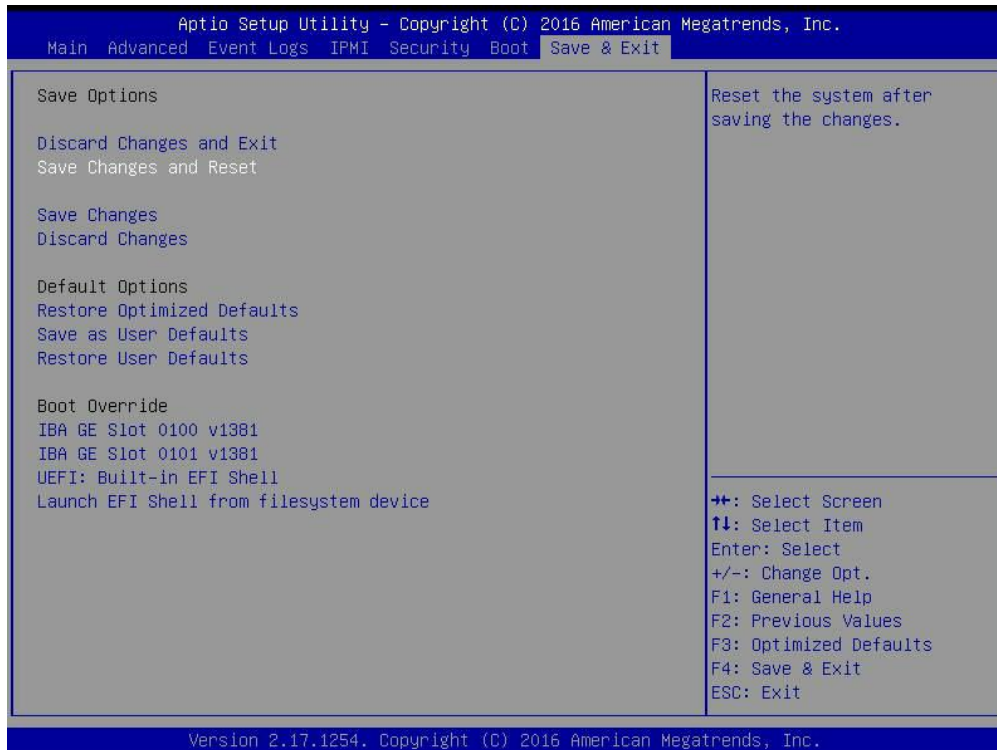

### Discard Changes and Exit

Select this option to quit the BIOS Setup without making any permanent changes to the system configuration, and reboot the computer. Select Discard Changes and Exit from the Exit menu and press <Enter>.

### Save Changes and Reset

When you have completed the system configuration changes, select this option to leave the BIOS setup utility and reboot the computer, so the new system configuration parameters can take effect. Select Save Changes and Exit from the Exit menu and press <Enter>.

### Save Changes

After completing the system configuration changes, select this option to save the changes you have made. This will not reset (reboot) the system.

### Discard Changes

Select this option and press <Enter> to discard all the changes and return to the AMI BIOS utility Program.

## **Default Options**

### **Restore Optimized Defaults**

To set this feature, select Restore Optimized Defaults from the Save & Exit menu and press <Enter>. These are factory settings designed for maximum system stability, but not for maximum performance.

### **Save As User Defaults**

To set this feature, select Save as User Defaults from the Exit menu and press <Enter>. This enables the user to save any changes to the BIOS setup for future use.

### **Restore User Defaults**

To set this feature, select Restore User Defaults from the Exit menu and press <Enter>. Use this feature to retrieve user-defined settings that were saved previously.

### **Boot Override**

Listed on this section are other boot options for the system (i.e., Built-in EFI shell). Select an option and press <Enter>. Your system will boot to the selected boot option.

## Appendix A

# Standardized Warning Statements for AC Systems

### About Standardized Warning Statements

The following statements are industry standard warnings, provided to warn the user of situations which have the potential for bodily injury. Should you have questions or experience difficulty, contact Supermicro's Technical Support department for assistance. Only certified technicians should attempt to install or configure components.

Read this appendix in its entirety before installing or configuring components in the Supermicro chassis.

These warnings may also be found on our website at [http://www.supermicro.com/about/policies/safety\\_information.cfm](http://www.supermicro.com/about/policies/safety_information.cfm).

### Warning Definition



**Warning!** This warning symbol means danger. You are in a situation that could cause bodily injury. Before you work on any equipment, be aware of the hazards involved with electrical circuitry and be familiar with standard practices for preventing accidents.

#### 警告の定義

この警告サインは危険を意味します。

人身事故につながる可能性がありますので、いずれの機器でも動作させる前に、電気回路に含まれる危険性に注意して、標準的な事故防止策に精通して下さい。

此警告符号代表危險。

您正处于可能受到严重伤害的工作环境中。在您使用设备开始工作之前，必须充分意识到触电的危险，并熟练掌握防止事故发生的标准工作程序。请根据每项警告结尾的声明号码找到此设备的安全性警告说明的翻译文本。

此警告符號代表危險。

您正處於可能身體可能會受損傷的工作環境中。在您使用任何設備之前，請注意觸電的危險，並且要熟悉預防事故發生的標準工作程序。請依照每一注意事項後的號碼找到相關的翻譯說明內容。

## Warnung

### WICHTIGE SICHERHEITSHINWEISE

Dieses Warnsymbol bedeutet Gefahr. Sie befinden sich in einer Situation, die zu Verletzungen führen kann. Machen Sie sich vor der Arbeit mit Geräten mit den Gefahren elektrischer Schaltungen und den üblichen Verfahren zur Vorbeugung vor Unfällen vertraut. Suchen Sie mit der am Ende jeder Warnung angegebenen Anweisungsnummer nach der jeweiligen Übersetzung in den übersetzten Sicherheitshinweisen, die zusammen mit diesem Gerät ausgeliefert wurden.

BEWAHREN SIE DIESE HINWEISE GUT AUF.

### INSTRUCCIONES IMPORTANTES DE SEGURIDAD

Este símbolo de aviso indica peligro. Existe riesgo para su integridad física. Antes de manipular cualquier equipo, considere los riesgos de la corriente eléctrica y familiarícese con los procedimientos estándar de prevención de accidentes. Al final de cada advertencia encontrará el número que le ayudará a encontrar el texto traducido en el apartado de traducciones que acompaña a este dispositivo.

GUARDE ESTAS INSTRUCCIONES.

### IMPORTANTES INFORMATIONS DE SÉCURITÉ

Ce symbole d'avertissement indique un danger. Vous vous trouvez dans une situation pouvant entraîner des blessures ou des dommages corporels. Avant de travailler sur un équipement, soyez conscient des dangers liés aux circuits électriques et familiarisez-vous avec les procédures couramment utilisées pour éviter les accidents. Pour prendre connaissance des traductions des avertissements figurant dans les consignes de sécurité traduites qui accompagnent cet appareil, référez-vous au numéro de l'instruction situé à la fin de chaque avertissement.

CONSERVEZ CES INFORMATIONS.

## תקנון הזהרות אזהרה

הזהרות הבאות הן אזהרות על פי תקני התעשייה, על מנת להזהיר את המשתמש מפני חבלה פיזית אפשרית. במידה ויש שאלות או היתקלות בבעיה כלשהי, יש ליצור קשר עם מחלקת תמיכה טכנית של סופרמיקרו. טכנאים מוסמכים בלבד רשאים להתקין או להגדיר את הרכיבים. יש לקרוא את הנספח במלואו לפני התקנת או הגדרת הרכיבים במארזי סופרמיקרו.

اَكْ ف حالة وُكِي اَي تتسبب ف اصابة جسدهُ هذا الزهز عُ خطر! تحذُرُ .  
 قبل اَي تعول على اَي هعدات، كي على علن بالوخاطز ال اُجوة عي الذوائر  
 الكهزبائِة  
 وكي على دراةُ بالووارسات النقاائِة لو عُ وقع اَي حادث  
 استخدم رقن الب اِي الو صُص ف هاةُ كل تحذُرُ للعشر تزجوتها

안전을 위한 주의사항

경고!

이 경고 기호는 위험이 있음을 알려 줍니다. 작업자의 신체에 부상을 야기 할 수 있는 상태에 있게 됩니다. 모든 장비에 대한 작업을 수행하기 전에 전기회로와 관련된 위험요소들을 확인하시고 사전에 사고를 방지할 수 있도록 표준 작업절차를 준수해 주시기 바랍니다.

해당 번역문을 찾기 위해 각 경고의 마지막 부분에 제공된 경고문 번호를 참조하십시오

## BELANGRIJKE VEILIGHEIDSINSTRUCTIES

Dit waarschuwings symbool betekent gevaar. U verkeert in een situatie die lichamelijk letsel kan veroorzaken. Voordat u aan enige apparatuur gaat werken, dient u zich bewust te zijn van de bij een elektrische installatie betrokken risico's en dient u op de hoogte te zijn van de standaard procedures om ongelukken te voorkomen. Gebruik de nummers aan het eind van elke waarschuwing om deze te herleiden naar de desbetreffende locatie.

## BEWAAR DEZE INSTRUCTIES

### Installation Instructions



**Warning!** Read the installation instructions before connecting the system to the power source.

設置手順書

システムを電源に接続する前に、設置手順書をお読み下さい。

警告

将此系统连接电源前,请先阅读安装说明。

警告

將系統與電源連接前，請先閱讀安裝說明。

**Warnung**

Vor dem Anschließen des Systems an die Stromquelle die Installationsanweisungen lesen.

**¡Advertencia!**

Lea las instrucciones de instalación antes de conectar el sistema a la red de alimentación.

**Attention**

Avant de brancher le système sur la source d'alimentation, consulter les directives d'installation.

יש לקרוא את הוראות התקנה לפני חיבור המערכת למקור מתח.

اقر إرشادات التركيب قبل توصيل النظام إلى مصدر للطاقة

시스템을 전원에 연결하기 전에 설치 안내를 읽어주십시오.

**Waarschuwing**

Raadpleeg de installatie-instructies voordat u het systeem op de voedingsbron aansluit.

**Circuit Breaker**

**Warning!** This product relies on the building's installation for short-circuit (overcurrent) protection. Ensure that the protective device is rated not greater than: 250 V, 20 A.

**サーキット・ブレーカー**

この製品は、短絡(過電流)保護装置がある建物での設置を前提としています。

保護装置の定格が250 V、20 Aを超えないことを確認下さい。

**警告**

此产品的短路(过载电流)保护由建筑物的供电系统提供,确保短路保护设备的额定电流不大于250V,20A。

**警告**

此產品的短路(過載電流)保護由建築物的供電系統提供,確保短路保護設備的額定電流不大於250V,20A。

**Warnung**

Dieses Produkt ist darauf angewiesen, dass im Gebäude ein Kurzschluss- bzw. Überstromschutz installiert ist. Stellen Sie sicher, dass der Nennwert der Schutzvorrichtung nicht mehr als: 250 V, 20 A beträgt.

**¡Advertencia!**

Este equipo utiliza el sistema de protección contra cortocircuitos (o sobrecorrientes) del edificio. Asegúrese de que el dispositivo de protección no sea superior a: 250 V, 20 A.

**Attention**

Pour ce qui est de la protection contre les courts-circuits (surtension), ce produit dépend de l'installation électrique du local. Vérifiez que le courant nominal du dispositif de protection n'est pas supérieur à :250 V, 20 A.

מוצר זה מסתמך על הגנה המותקנת במבנים למניעת קצר חשמלי. יש לוודא כי המכשיר המגן מפני הקצר החשמלי הוא לא יותר מ-250VDC, 20A

هذا المنتج يعتمد على معدات الحماية مه الدوائر القصيرة التي تم تثبيتها في المبنى  
تأكد من أن تقييم الجهاز الوقائي ليس أكثر من : 20A, 250V

**경고!**

이 제품은 전원의 단락(과전류)방지에 대해서 전적으로 건물의 관련 설비에 의존합니다. 보호장치의 정격이 반드시 250V(볼트), 20A(암페어)를 초과하지 않도록 해야 합니다.

**Waarschuwing**

Dit product is afhankelijk van de kortsluitbeveiliging (overspanning) van uw elektrische installatie. Controleer of het beveiligde apparaat niet groter gedimensioneerd is dan 250V, 20A.

## Power Disconnection Warning



**Warning!** The system must be disconnected from all sources of power and the power cord removed from the power supply module(s) before accessing the chassis interior to install or remove system components (except for hot-swap components).



### 電源切断の警告

システムコンポーネントの取り付けまたは取り外しのために、シャーシ内部にアクセスするには、システムの電源はすべてのソースから切断され、電源コードは電源モジュールから取り外す必要があります。

### 警告

在你打开机箱并安装或移除内部器件前,必须将系统完全断电,并移除电源线。

### 警告

在您打開機殼安裝或移除內部元件前，必須將系統完全斷電，並移除電源線。

### Warnung

Das System muss von allen Quellen der Energie und vom Netzanschlusskabel getrennt sein, das von den Spg.Versorgungsteilmodulen entfernt wird, bevor es auf den Chassisinnenraum zurückgreift, um Systemsbestandteile anzubringen oder zu entfernen.

### ¡Advertencia!

El sistema debe ser disconnected de todas las fuentes de energía y del cable eléctrico quitado de los módulos de fuente de alimentación antes de tener acceso el interior del chasis para instalar o para quitar componentes de sistema.

### Attention

Le système doit être débranché de toutes les sources de puissance ainsi que de son cordon d'alimentation secteur avant d'accéder à l'intérieur du chassis pour installer ou enlever des composants de système.

אזהרה מפני ניתוק חשמלי

אזהרה!

יש לנתק את המערכת מכל מקורות החשמל ויש להסיר את כבל החשמלי מהספק לפני גישה לחלק הפנימי של המארז לצורך התקנת או הסרת רכיבים.

يجب فصل انظاؤ من جميع مصادر انطاقت وإزانت سهك انكهرباء من وحدة امداد انطاقت قيم

انصل إلى امناطق انداخييت نههيكم نشييح أو إزانت مكنناث الجهاز

경고!

시스템에 부품들을 장착하거나 제거하기 위해서는 새시 내부에 접근하기 전에 반드시 전원 공급장치로부터 연결되어있는 모든 전원과 전기코드를 분리해주어야 합니다.

Waarschuwing

Voordat u toegang neemt tot het binnenwerk van de behuizing voor het installeren of verwijderen van systeem onderdelen, dient u alle spanningsbronnen en alle stroomkabels aangesloten op de voeding(en) van de behuizing te verwijderen

## Equipment Installation



**Warning!** Only authorized personnel and qualified service persons should be allowed to install, replace, or service this equipment.

機器の設置

トレーニングを受け認定された人だけがこの装置の設置、交換、またはサービスを許可されています。

警告

只有经过培训且具有资格的人员才能进行此设备的安装、更换和维修。

警告

只有經過受訓且具資格人員才可安裝、更換與維修此設備。

Warnung

Nur autorisiertes Personal und qualifizierte Servicetechniker dürfen dieses Gerät installieren, austauschen oder warten..

¡Advertencia!

Sólo el personal autorizado y el personal de servicio calificado deben poder instalar, reemplazar o dar servicio a este equipo.

**Attention**

Seul le personnel autorisé et le personnel de maintenance qualifié doivent être autorisés à installer, remplacer ou entretenir cet équipement..

אזהרה!

יש לאפשר רק צוות מורשה ואנשי שירות מוסמכים להתקין, להחליף או לטפל בציוד זה.

ينبغي السماح فقط للموظفين المعتمدين وأفراد الخدمة المؤهلين بتركيب هذا الجهاز أو استبداله أو صيانته.

**경고!**

승인된 직원과 자격을 갖춘 서비스 담당자만이 이 장비를 설치, 교체 또는 서비스할 수 있습니다.

**Waarschuwing**

Alleen geautoriseerd personeel en gekwalificeerd onderhoudspersoneel mag deze apparatuur installeren, vervangen of onderhouden..

**Restricted Area**

**Warning!** This unit is intended for installation in restricted access areas. A restricted access area can be accessed only through the use of a special tool, lock and key, or other means of security. (This warning does not apply to workstations).

**アクセス制限区域**

このユニットは、アクセス制限区域に設置されることを想定しています。

アクセス制限区域は、特別なツール、鍵と錠前、その他のセキュリティの手段を用いてのみ出入りが可能です。

**警告**

此部件应安装在限制进出的场所，限制进出的场所指只能通过使用特殊工具、锁和钥匙或其它安全手段进出的场所。

**警告**

此裝置僅限安裝於進出管制區域，進出管制區域係指僅能以特殊工具、鎖頭及鑰匙或其他安全方式才能進入的區域。

**Warnung**

Diese Einheit ist zur Installation in Bereichen mit beschränktem Zutritt vorgesehen. Der Zutritt zu derartigen Bereichen ist nur mit einem Spezialwerkzeug, Schloss und Schlüssel oder einer sonstigen Sicherheitsvorkehrung möglich.

**¡Advertencia!**

Esta unidad ha sido diseñada para instalación en áreas de acceso restringido. Sólo puede obtenerse acceso a una de estas áreas mediante la utilización de una herramienta especial, cerradura con llave u otro medio de seguridad.

**Attention**

Cet appareil doit être installée dans des zones d'accès réservés. L'accès à une zone d'accès réservé n'est possible qu'en utilisant un outil spécial, un mécanisme de verrouillage et une clé, ou tout autre moyen de sécurité.

אזור עם גישה מוגבלת

אזהרה!

יש להתקין את היחידה באזורים שיש בהם הגבלת גישה. הגישה ניתנת בעזרת 'כלי אבטחה בלבד' (מפתח, מנעול וכד.).

تخصيص هذه انحدة نترك بُها ف مناطق محظورة تم .  
ممكن انصلل إن منطقت محظورة فقط من خلال استخذاو أداة خاصت  
أو أ وس هُت أخري نلالأمما ققم ومفتاح

**경고!**

이 장치는 접근이 제한된 구역에 설치하도록 되어있습니다. 특수도구, 잠금 장치 및 키, 또는 기타 보안 수단을 통해서만 접근 제한 구역에 들어갈 수 있습니다.

**Waarschuwing**

Dit apparaat is bedoeld voor installatie in gebieden met een beperkte toegang. Toegang tot dergelijke gebieden kunnen alleen verkregen worden door gebruik te maken van speciaal gereedschap, slot en sleutel of andere veiligheidsmaatregelen.

## Battery Handling



**CAUTION:** There is risk of explosion if the battery is replaced by an incorrect type. Replace the battery only with the same or equivalent type recommended by the manufacturer. Dispose of used batteries according to the manufacturer's instructions

### 電池の取り扱い

バッテリーを間違ったタイプに交換すると爆発の危険があります。交換する電池はメーカーが推奨する型、または同等のものを使用下さい。使用済電池は製造元の指示に従って処分して下さい。

### 警告

如果更换的电池类型不正确，则存在爆炸危险。请只使用同类电池或制造商推荐的功能相当的电池更换原有电池。请按制造商的说明处理废旧电池。

### 警告

如果更換的電池類型不正確，則有爆炸危險。請使用製造商建議之相同或功能相當的電池更換原有電池。請按照製造商的說明指示處理廢棄舊電池。

### WARNUNG

Es besteht Explosionsgefahr, wenn die Batterie durch einen falschen Typ ersetzt wird. Ersetzen Sie die Batterie nur durch den gleichen oder vom Hersteller empfohlenen Batterietyp. Entsorgen Sie die benutzten Batterien nach den Anweisungen des Herstellers.

### ATTENTION

Il existe un risque d'explosion si la batterie est remplacée par un type incorrect. Ne la remplacer que par une pile de type semblable ou équivalent, recommandée par le fabricant. Jeter les piles usagées conformément aux instructions du fabricant.

### ADVERTENCIA

Existe riesgo de explosión si la batería se reemplaza por un tipo incorrecto. Reemplazar la batería exclusivamente con el mismo tipo o el equivalente recomendado por el fabricante. Desechar las baterías gastadas según las instrucciones del fabricante.

אזהרה!

קיימת סכנת פיצוץ אם הסוללה תוחלף בסוג שגוי. יש להחליף את הסוללה בסוג התואם מחברת יצרן מומלצת. סילוק הסוללות המשומשות יש לבצע לפי הוראות היצרן.

هناك خطر الانفجار إذا تم استبدال البطارية بنوع غير صحيح.  
 اسحبذال البطارية  
 فقط بنفس النوع أو ما يعادلها مما أوصت به الشركة المصنعة  
 جخلص من البطاريات المسحمة وفقا لعمليات الشركة الصانعة

경고!

배터리를 잘못된 종류로 교체하면 폭발의 위험이 있습니다. 기존 배터리와 동일하거나 제조사에서 권장하는 동등한 종류의 배터리로만 교체해야 합니다. 제조사의 안내에 따라 사용된 배터리를 처리하여 주십시오.

### WAARSCHUWING

Er bestaat explosiegevaar als de batterij wordt vervangen door een verkeerd type. Vervang de batterij slechts met hetzelfde of een equivalent type die door de fabrikant aanbevolen wordt. Gebruikte batterijen dienen overeenkomstig fabrieksvoorschriften afgevoerd te worden.

## Redundant Power Supplies



**Warning!** This unit might have more than one power supply connection. All connections must be removed to de-energize the unit.

冗長電源装置

このユニットは複数の電源装置が接続されている場合があります。

ユニットの電源を切るためには、すべての接続を取り外さなければなりません。

警告

此部件连接的电源可能不止一个，必须将所有电源断开才能停止给该部件供电。

警告

此装置连接的电源可能不只一个，必须切断所有电源才能停止对该装置的供电。

Warnung

Dieses Gerät kann mehr als eine Stromzufuhr haben. Um sicherzustellen, dass der Einheit kein Strom zugeführt wird, müssen alle Verbindungen entfernt werden.

## ¡Advertencia!

Puede que esta unidad tenga más de una conexión para fuentes de alimentación. Para cortar por completo el suministro de energía, deben desconectarse todas las conexiones.

## Attention

Cette unité peut avoir plus d'une connexion d'alimentation. Pour supprimer toute tension et tout courant électrique de l'unité, toutes les connexions d'alimentation doivent être débranchées.

אם קיים יותר מספק אחד

אזהרה!

ליחידה יש יותר מחיבור אחד של ספק. יש להסיר את כל החיבורים על מנת לרוקן את היחידה.

قد يكون لهذا الجهاز عدة اتصالات بوحدات امداد الطاقة .  
يجب إزالة كافة الاتصالات لعسل الوحدة عن الكهرباء

## 경고!

이 장치에는 한 개 이상의 전원 공급 단자가 연결되어 있을 수 있습니다. 이 장치에 전원을 차단하기 위해서는 모든 연결 단자를 제거해야만 합니다.

## Waarschuwing

Deze eenheid kan meer dan één stroomtoevoeraansluiting bevatten. Alle aansluitingen dienen verwijderd te worden om het apparaat stroomloos te maken.

## Backplane Voltage



**Warning!** Hazardous voltage or energy is present on the backplane when the system is operating. Use caution when servicing.

バックプレーンの電圧

システムの稼働中は危険な電圧または電力が、バックプレーン上にかかっています。

修理する際には注意ください。

警告

当系统正在进行时，背板上有很危险的电压或能量，进行维修时务必小心。

警告

當系統正在進行時，背板上有危險的電壓或能量，進行維修時務必小心。

Warnung

Wenn das System in Betrieb ist, treten auf der Rückwandplatine gefährliche Spannungen oder Energien auf. Vorsicht bei der Wartung.

¡Advertencia!

Cuando el sistema está en funcionamiento, el voltaje del plano trasero es peligroso. Tenga cuidado cuando lo revise.

Attention

Lorsque le système est en fonctionnement, des tensions électriques circulent sur le fond de panier. Prendre des précautions lors de la maintenance.

מתח בפנל האחורי

אזהרה!

קיימת סכנת מתח בפנל האחורי בזמן תפעול המערכת. יש להיזהר במהלך העבודה.

هناك خطر من التيار الكهربائي أو الطاقة المتجددة على اللوحة  
عندما يكون النظام يعمل كه حذرا عند خدمة هذا الجهاز

경고!

시스템이 동작 중일 때 후면판 (Backplane)에는 위험한 전압이나 에너지가 발생 합니다.  
서비스 작업 시 주의하십시오.

Waarschuwing

Een gevaarlijke spanning of energie is aanwezig op de backplane wanneer het systeem in gebruik is. Voorzichtigheid is geboden tijdens het onderhoud.

## Comply with Local and National Electrical Codes



**Warning!** Installation of the equipment must comply with local and national electrical codes.

地方および国の電気規格に準拠

機器の取り付けはその地方および国の電気規格に準拠する必要があります。

警告

设备安装必须符合本地与本国电气法规。

警告

設備安裝必須符合本地與本國電氣法規。

Warnung

Die Installation der Geräte muss den Sicherheitsstandards entsprechen.

¡Advertencia!

La instalación del equipo debe cumplir con las normas de electricidad locales y nacionales.

Attention

L'équipement doit être installé conformément aux normes électriques nationales et locales.

תיאום חוקי החשמל הארצי  
אזהרה!  
התקנת הציוד חייבת להיות תואמת לחוקי החשמל המקומיים והארציים.

تركيب المعدات الكهربائية يجب أن يمتثل للقوايه المحلية والبطية المتعلقة  
بالكهرباء

경고!

현 지역 및 국가의 전기 규정에 따라 장비를 설치해야 합니다.

Waarschuwing

Bij installatie van de apparatuur moet worden voldaan aan de lokale en nationale elektriciteitsvoorschriften.

## Product Disposal



**Warning!** Ultimate disposal of this product should be handled according to all national laws and regulations.

製品の廃棄

この製品を廃棄処分する場合、国の関係する全ての法律・条例に従い処理する必要があります。

警告

本产品的废弃处理应根据所有国家的法律和规章进行。

警告

本產品的廢棄處理應根據所有國家的法律和規章進行。

Warnung

Die Entsorgung dieses Produkts sollte gemäß allen Bestimmungen und Gesetzen des Landes erfolgen.

¡Advertencia!

Al deshacerse por completo de este producto debe seguir todas las leyes y reglamentos nacionales.

## Attention

La mise au rebut ou le recyclage de ce produit sont généralement soumis à des lois et/ou directives de respect de l'environnement. Renseignez-vous auprès de l'organisme compétent.

סילוק המוצר

אזהרה!

סילוק סופי של מוצר זה חייב להיות בהתאם להנחיות וחוקי המדינה.

التخلص النهائي من هذا المنتج ينبغي التعامل معه وفقا لجميع القوانين واللوائح الوطنية عند

경고!

이 제품은 해당 국가의 관련 법규 및 규정에 따라 폐기되어야 합니다.

## Waarschuwing

De uiteindelijke verwijdering van dit product dient te geschieden in overeenstemming met alle nationale wetten en reglementen.

## Fan Warning



**Warning!** Hazardous moving parts. Keep away from moving fan blades. The fans might still be turning when you remove the fan assembly from the chassis. Keep fingers, screwdrivers, and other objects away from the openings in the fan assembly's housing.

ファンの警告

警告!回転部品に注意。運転中は回転部(羽根)に触れないでください。シャーシから冷却ファン装置を取り外した際、ファンがまだ回転している可能性があります。ファンの開口部に、指、ドライバー、およびその他のものを近づけないで下さい。

警告!

警告! 危险的可移动性零件。请务必与转动的风扇叶片保持距离。当您从机架移除风扇装置，风扇可能仍在转动。小心不要将手指、螺丝起子和其他物品太靠近风扇

警告

危险的可移动性零件。请务必与转动的风扇叶片保持距离。当您从机架移除风扇装置，风扇可能仍在转动。小心不要将手指、螺丝起子和其他物品太靠近风扇。

**Warnung**

Gefährlich Bewegende Teile. Von den bewegenden Lüfterblätter fern halten. Die Lüfter drehen sich u. U. noch, wenn die Lüfterbaugruppe aus dem Chassis genommen wird. Halten Sie Finger, Schraubendreher und andere Gegenstände von den Öffnungen des Lüftergehäuses entfernt.

**¡Advertencia!**

Riesgo de piezas móviles. Mantener alejado de las aspas del ventilador. Los ventiladores podran dar vuelta cuando usted quite el montaje del ventilador del chasis. Mantenga los dedos, los destornilladores y todos los objetos lejos de las aberturas del ventilador

**Attention**

Pieces mobiles dangereuses. Se tenir a l'écart des lames du ventilateur Il est possible que les ventilateurs soient toujours en rotation lorsque vous retirerez le bloc ventilateur du châssis. Prenez garde à ce que doigts, tournevis et autres objets soient éloignés du logement du bloc ventilateur.

**אזהרה!**

חלקים נעים מסוכנים. התרחק מלהבי המאוורר בפעולה כאשר מסירים את חלקי המאוורר מהמארז, יתכן והמאווררים עדיין עובדים. יש להרחיק למרחק בטוח את האצבעות וכלי עבודה שונים מהפתחים בתוך המאוורר

تحذير! أجزاء متحركة خطيرة. ابتعد عن شفرات المروحة المتحركة. من الممكن أن المراوح لا تزال تدور عند إزالة كتلة المروحة من الهيكل يجب إبقاء الأصابع ومفكات البراغي وغيرها من الأشياء بعيدا عن الفتحات في كتلة المروحة.

**경고!**

움직이는 위험한 부품. 회전하는 송풍 날개에 접근하지 마세요. 새시로부터 팬 조립품을 제거할 때 팬은 여전히 회전하고 있을 수 있습니다. 팬 조립품 외관의 열려있는 부분들로부터 손가락 및 스크류드라이버, 다른 물체들이 가까이 하지 않도록 배치해 주십시오.

**Waarschuwing**

Gevaarlijk bewegende onderdelen. Houd voldoende afstand tot de bewegende ventilatorbladen. Het is mogelijk dat de ventilator nog draait tijdens het verwijderen van het ventilatorsamenstel uit het chassis. Houd uw vingers, schroevendraaiers en eventuele andere voorwerpen uit de buurt van de openingen in de ventilatorbehuizing.

## Power Cable and AC Adapter



**Warning!** When installing the product, use the provided or designated connection cables, power cables and AC adaptors. Using any other cables and adaptors could cause a malfunction or a fire. Electrical Appliance and Material Safety Law prohibits the use of UL or CSA -certified cables (that have UL/CSA shown on the cord) for any other electrical devices than products designated by Supermicro only.

### 電源コードとACアダプター

製品を設置する場合、提供または指定および購入された接続ケーブル、電源コードとACアダプターを該当する地域の条例や安全基準に適合するコードサイズやプラグと共に使用下さい。他のケーブルやアダプタを使用すると故障や火災の原因になることがあります。

電気用品安全法は、ULまたはCSA認定のケーブル(UL/CSAマークがコードに表記)を Supermicro が指定する製品以外に使用することを禁止しています。

### 警告

安装此产品时,请使用本身提供的或指定的或采购的连接线,电源线和电源适配器。包含遵照当地法规和安全要求的合规的电源线尺寸和插头。使用其它线材或适配器可能会引起故障或火灾。除了Supermicro所指定的产品,电气用品和材料安全法律规定禁止使用未经UL或CSA认证的线材。(线材上会显示UL/CSA符号)。

### 警告

安裝此產品時,請使用本身提供的或指定的或採購的連接線,電源線和電源適配器。包含遵照當地法規和安全要求的合規的電源線尺寸和插頭。使用其它線材或適配器可能會引起故障或火災。除了Supermicro所指定的產品,電氣用品和材料安全法律規定禁止使用未經UL或CSA認證的線材。(線材上會顯示UL/CSA符號)。

### Warnung

Nutzen Sie beim Installieren des Produkts ausschließlich die von uns zur Verfügung gestellten Verbindungskabeln, Stromkabeln und/oder Adapter, die Ihre örtlichen Sicherheitsstandards einhalten. Der Gebrauch von anderen Kabeln und Adapter können Fehlfunktionen oder Feuer verursachen. Die Richtlinien untersagen das Nutzen von UL oder CAS zertifizierten Kabeln (mit UL/CSA gekennzeichnet), an Geräten oder Produkten die nicht mit Supermicro gekennzeichnet sind.

## ¡Advertencia!

Cuando instale el producto, utilice la conexión provista o designada o procure cables, Cables de alimentación y adaptadores de CA que cumplan con los códigos locales y los requisitos de seguridad, incluyendo el tamaño adecuado del cable y el enchufe. El uso de otros cables y adaptadores podría causar un mal funcionamiento o un incendio. La Ley de Seguridad de Aparatos Eléctricos y de Materiales prohíbe El uso de cables certificados por UL o CSA (que tienen el certificado UL / CSA en el código) para cualquier otros dispositivos eléctricos que los productos designados únicamente por Supermicro.

## Attention

Lors de l'installation du produit, utilisez les cables de connection fournis ou désigné ou achetez des cables, cables de puissance et adaptateurs respectant les normes locales et les conditions de securite y compris les tailles de cables et les prises electriques appropriées. L'utilisation d'autres cables et adaptateurs peut provoquer un dysfonctionnement ou un incendie. Appareils électroménagers et la Loi sur la Sécurité Matériel interdit l'utilisation de câbles certifiés- UL ou CSA (qui ont UL ou CSA indiqué sur le code) pour tous les autres appareils électriques sauf les produits désignés par Supermicro seulement.

AC ימאתמו מילמשח מילבכ

!הרהזא

רְרוּצַל וּמֵאֵתוֹהּ וְאֵשְׁכֵרֵנּוּ רֵשֶׁא AC מֵימֵאֵתְמוּ מִיִּקְפֵס, מֵיִלְבֵכֵב שֶׁמִתְשֶׁהֶל שִׁי, רֵצוּמָה תָא מֵינִיקְתֵּם רֵשֶׁאֵכּ לֵכֵב שׁוּמִישׁ . עֵקֶתָהּ לֵבֵכָה לֵשׁ הַנּוֹכֵחַ הַדִּימ לֵלוֹכ, תּוֹיּוּמֻקְמָה תּוֹחִיטְבָה תּוֹשִׁירְדֵל וּמֵאֵתוֹהּ רֵשֶׁאוּ, הַנִּקְתָהּ לִמְשַׁחָה יִרְשַׁכְמֵב שׁוּמִישָׁה יִקּוּחַל מֵאֵתָהּב . יִלְמִשַׁח רֵצֵק וְאֵ הַלְקֵתֵל מִוִּרְגֵל לִוְלַע, רֵחָא גֹוּסֵם מֵאֵתֵם וְאֵ לֵבֵכ לֵשׁ דּוֹק מֵהִילַע עֵיפּוּם רֵשֶׁאֵכּ) UL-ב וְCSA-ב וְUL-ב מֵיִכְמִסוּמָה מֵיִלְבֵכֵב שֶׁמִתְשֶׁהֶל רוּסִיָא מֵיִיק, תּוֹחִיטְבָה יִקּוּחַ דֵּבֵלֵב Supermicro יִ"ע מֵאֵתוֹהּ רֵשֶׁא רֵצוּמֵב קֵר אֵלָא, רֵחָא יִלְמִשַׁח רֵצוּם לֵכ רוּבַע (UL/CSA)

תֵּאֲלֵבֵאֵלָא אֵרְשֵׁב מִקּ וְאֵ תִדְדַחְמָלָא וְאֵ תֵרְפוֹתֵמֵלָא תֵאֲלֵיִוִּסְוֵתֵלָא מֵאֲדַחְתֵּסֵאֵב מִקּ, גֵּתֵנְמֵלָא בֵיִקְרֵת דֵּנַע לֵכֵלִז יִיִף אֵמֵב עֵיִלְחֵמֵלָא עֵמֵלְסֵלָא תֵאֲבֵלְטֵתְמוּ נֵיִנְאוּקֵב מֵאֲזֵתֵלֵלָא עֵם דֵּדֵרְתֵמֵלָא רֵאֵיִתֵלָא תֵאֲלוּחְמוּ עֵיִוִּיִּאֵבֵרְהֵלָלָא . קֵיִרְח וְאֵ לִטַע יִיִף בֵּבֵסֵתֵיִ דִּק יִרְחָא תֵאֲלוּחְמוּ תֵאֲלֵבֵאֵכֵיִ אֵ מֵאֲדַחְתֵּסֵאֵ . מֵיִלְסֵלָא סֵבֵאֲלָאוּ לִסְוִמֵלָא מִגֵּחַ . UL וְCSA לֵבֵק נֵם תֵּדְמֵתְעֵמֵלָא תֵּאֲלֵבֵאֵלָא מֵאֲדַחְתֵּסֵאֵ תֵאֲדַעְמֵלָאוּ עֵיִוִּיִּאֵבֵרְהֵלָלָא עֵזֵהֵגֵלֵל עֵמֵלְסֵלָא נִוִּנְאֻק רֵצְחֵי Supermicro לֵבֵק נֵם תֵּדְדַחְמֵלָאוּ עֵיִנְעֵמֵלָא תֵּאֲגֵתֵנְמֵלָא רֵיִג יִרְחָא תֵּאֲדַעְמֵיִ אֵ עֵם (UL/CSA) עֵמֵלְע לִמְחֵת יִתֵּלָאוּ

### 전원 케이블 및 AC 어댑터

경고! 제품을 설치할 때 현지 코드 및 적절한 굵기의 코드와 플러그를 포함한 안전 요구 사항을 준수하여 제공되거나 지정된 연결 혹은 구매 케이블, 전원 케이블 및 AC 어댑터를 사용하십시오.

다른 케이블이나 어댑터를 사용하면 오작동이나 화재가 발생할 수 있습니다. 전기 용품 안전법은 UL 또는 CSA 인증 케이블 (코드에 UL / CSA가 표시된 케이블)을 Supermicro가 지정한 제품 이외의 전기 장치에 사용하는 것을 금지합니다.

### Stroomkabel en AC-Adapter

Waarschuwing! Bij het aansluiten van het Product uitsluitend gebruik maken van de geleverde Kabels of een andere geschikte aan te schaffen Aansluitmethode, deze moet altijd voldoen aan de lokale voorschriften en veiligheidsnormen, inclusief de juiste kabeldikte en stekker. Het gebruik van niet geschikte Kabels en/of Adapters kan een storing of brand veroorzaken. Wetgeving voor Elektrische apparatuur en Materiaalveiligheid verbied het gebruik van UL of CSA -gecertificeerde Kabels (met UL/CSA in de code) voor elke andere toepassing dan de door Supermicro hiervoor beoogde Producten.

## Appendix B

# UEFI BIOS Recovery Instructions

**Warning:** Do not upgrade the BIOS unless your system has a BIOS-related issue. Flashing the wrong BIOS can cause irreparable damage to the system. In no event shall Supermicro be liable for direct, indirect, special, incidental, or consequential damages arising from a BIOS update. If you need to update the BIOS, do not shut down or reset the system while the BIOS is updating to avoid possible boot failure.

### C.1 An Overview to the UEFI BIOS

The Unified Extensible Firmware Interface (UEFI) provides a software-based interface between the operating system and the platform firmware in the pre-boot environment. The UEFI specification supports an architecture-independent mechanism for add-on card initialization to allow the UEFI OS loader, which is stored in the add-on card, to boot the system. The UEFI offers a clean, hands-off control to a computer system at bootup.

### C.2 How to Recover the UEFI BIOS Image (-the Main BIOS Block)

A UEFI BIOS flash chip consists of a recovery BIOS block and a main BIOS block (a main BIOS image). The boot block contains critical BIOS codes, including memory detection and recovery codes for the user to flash a new BIOS image if the original main BIOS image is corrupted. When the system power is on, the boot block codes execute first. Once it is completed, the main BIOS code will continue with system initialization and bootup.

**Note:** Follow the BIOS recovery instructions below for BIOS recovery when the main BIOS boot crashes. However, when the BIOS boot block crashes, you will need to follow the procedures below for BIOS recovery.

### C.3 To Recover the Main BIOS Block Using a USB-Attached Device

This feature allows the user to recover a BIOS image using a USB-attached device without additional utilities used. A USB flash device such as a USB Flash Drive, or a USB CD/DVD ROM/RW device can be used for this purpose. However, a USB Hard Disk drive cannot be used for BIOS recovery at this time.

The file system supported by UEFI is FAT (including FAT12, FAT16, and FAT32) installed on a bootable or non-bootable USB-attached device. However, the BIOS might need several minutes to locate the SUPER.ROM file if the media size becomes too large because it contains too many folders and files.

To perform UEFI BIOS recovery using a USB-attached device, follow the instructions below.

1. Using a different machine, copy the "Super.ROM" binary image file into the disc Root "\\" Directory of a USB device or a writeable CD/DVD.

**Note:** If you cannot locate the "Super.ROM" file in your driver disk, visit our website at [www.supermicro.com](http://www.supermicro.com) to download the BIOS image into a USB flash device and rename it "Super.ROM" for BIOS recovery use.

2. Insert the USB device that contains the new BIOS image ("Super.ROM") into your USB drive and power on the system
3. While powering on the system, please keep pressing <Ctrl> and <Home> simultaneously on your keyboard *until the following screen (or a screen similar to the one below) displays.*

**Caution:** Please **stop** pressing the <Ctrl> and <Home> keys immediately when you see the screen (or a similar screen) below; otherwise, it will trigger a system reboot.

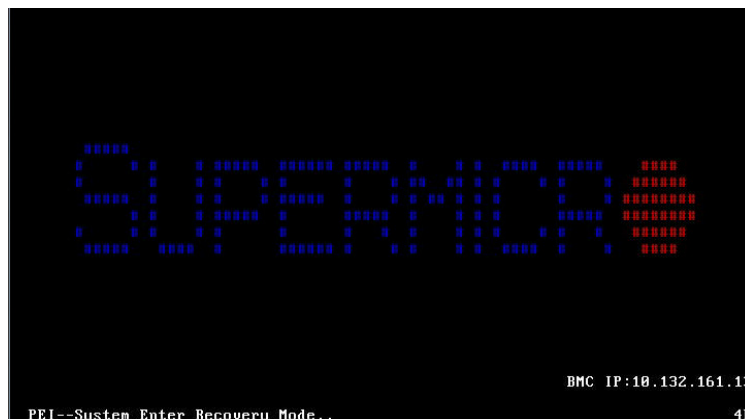

**Note:** On the other hand, if the following screen displays, please load the "Super.ROM" file to the root folder and connect this folder to the system. (You can do so by inserting a USB device that contains the new "Super.ROM" image to your machine for BIOS recovery.)



4. After locating the new BIOS binary image, the system will enter the BIOS Recovery menu as shown below.

**Note:** At this point, you may decide if you want to start with BIOS recovery. If you decide to proceed with BIOS recovery, follow the procedures below.

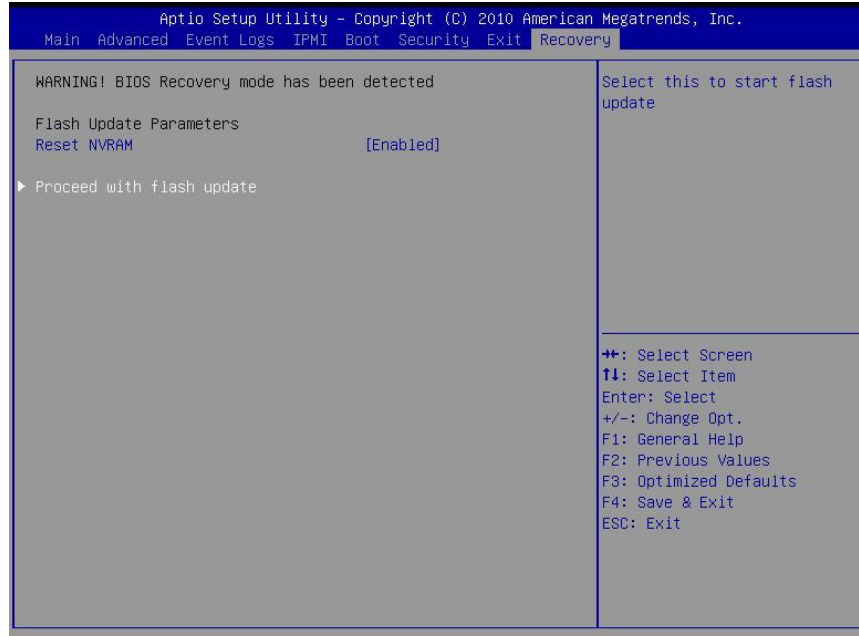

5. When the screen as shown above displays, using the arrow key, select the item "Proceed with flash update" and press the <Enter> key. You will see the progress of BIOS recovery as shown in the screen below.

**Note:** *Do not interrupt* the process of BIOS flashing until it is completed.

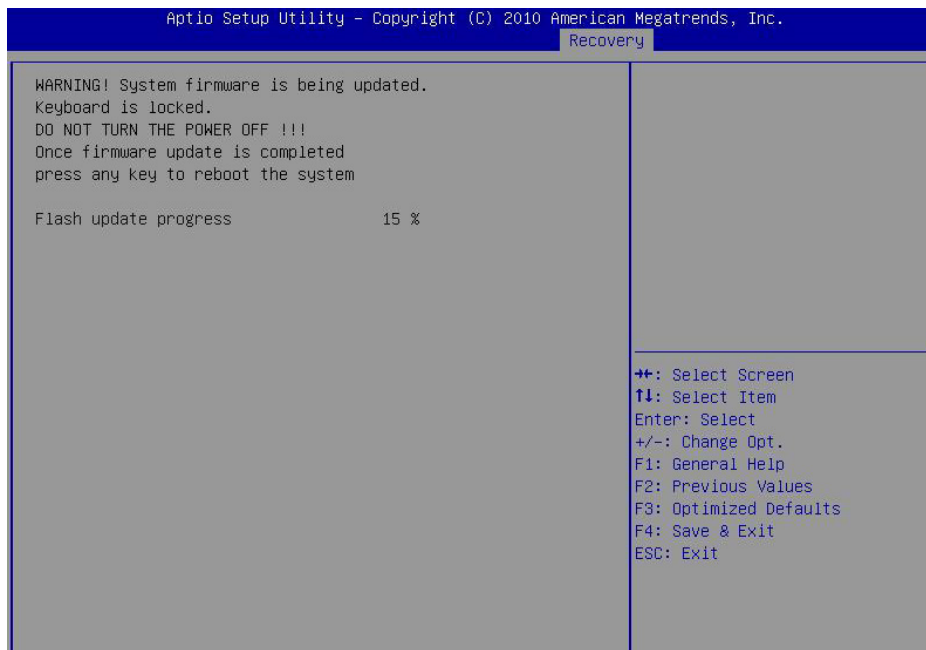

6. After the process of BIOS recovery is completed, press any key to reboot the system.

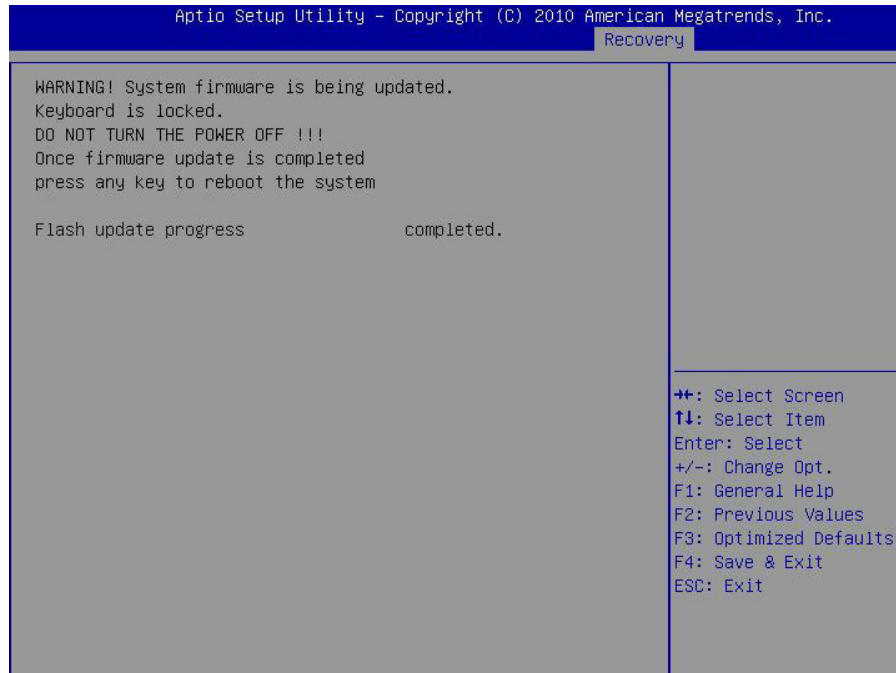

7. Using a different system, extract the BIOS package into a bootable USB flash drive.
8. When a DOS prompt appears, enter `FLASH.BAT BIOSname.###` at the prompt.  
**Note:** *Do not interrupt this process* until BIOS flashing is completed.
9. After seeing the message that BIOS update is completed, unplug the AC power cable from the power supply to clear the CMOS, and then plug the AC power cable in the power supply again to power on the system.
10. Press <Del> continuously to enter the BIOS Setup utility.
11. Press <F3> to load default settings.
12. After loading default settings, press <F4> to save the settings and exit the BIOS Setup utility.

# Appendix C

## System Specifications

### Processors

Single Intel Xeon E-2100 in an H4 LGA1151 type socket, 95W max TDP.

**Note:** The system does not support the redundant power feature under special circumstances when the CPUs are under Turbo mode or all CPUs consume 95W or more under stress simultaneously. The thermal throttle is normal when Intel Turbo Boost Technology is active.

**Note:** Please refer to the motherboard specifications pages on our website for updates to supported processors.

### Chipset

Intel PCH C246 chipset

### BIOS

128 Mb UEFI

### Memory

Four DIMM slots that can support up to 128 GB of ECC Very Low Profile (VLP) 2666 MHz

### SATA Controller

On-chip (Intel PCH C246) controller

### Drive Bays

Internal, non-hot-swap; each node supports two 3.5" SATA3 drives, or four 2.5" SATA3 drives, or two 2.5" NVMe and two 2.5" SATA3 drives, or two 2.5" NVMe and one 3.5" SATA3 drive

### PCI Expansion Slots

One Micro LP PCI-E 3.0, one M.2 PCI-E slot with SATA3 support, two NVMe U.2 PCI-E slots via the backplane

### Motherboard

X11SCE-F; (proprietary form factor)

Dimensions: 4.6" x 11.7" (11.68 x 29.72 cm)

### Chassis

SC939HC-R2K04BP; 3U rackmount,

Dimensions: (WxHxD) 17.5 x 5.21 x 31 in. (444.5 x 132 x 787.4 mm)

### Weight

Net with 3.5" HDDs: 132 lbs (59.87 kg)

Gross: 125 lbs (56.70 kg)

### System Cooling

Four 9-cm heavy duty fans with optimal cooling zone

### Power Supply

Model: PWS-2K04F-1R, 80+ level Titanium  
Total Output Power: 1000W/1800W/1980W/2000W  
AC Input Voltages: 100-127 V, 200-220 V, 220-230 V, 230-240 V, 200-240V  
Rated Input Frequency: 50-60 Hz  
Rated Output Power:  
12V  
Max: 83.3A & Min: 0A (100Vac-127Vac)  
Max: 150A & Min: 0A (200Vac-220Vac)  
Max: 165A & Min: 0A (220Vac-230Vac)  
Max: 166.7A & Min: 0A (230Vac-240Vac)  
5V SB:  
Max: 1A / Min: 0A  
Output Type:  
27 Pairs Gold Finger Connector

### Operating Environment

Operating Temperature: 10° to 35° C (50° to 95° F)  
Non-operating Temperature: -40° to 70° C (-40° to 158° F)  
Operating Relative Humidity: 8% to 90% (non-condensing)  
Non-operating Relative Humidity: 5% to 95% (non-condensing)

### Regulatory Compliance

Electromagnetic Emissions: FCC Class A, EN 55022 Class A, EN 61000-3-2/3-3, CISPR 22 Class A  
Electromagnetic Immunity: EN 55024/CISPR 24, (EN 61000-4-2, EN 61000-4-3, EN 61000-4-4, EN 61000-4-5, EN 61000-4-6, EN 61000-4-8, EN 61000-4-11)  
Environmental: Directive 2011/65/EU, Deligated Directive (EU) 2015/863, and Directive 2012/19/EU  
Safety: CSA/EN/IEC/UL 60950-1 Compliant, UL or CSA Listed (USA and Canada), CE Marking (Europe)

### Perchlorate Warning

California Best Management Practices Regulations for Perchlorate Materials: This Perchlorate warning applies only to products containing CR (Manganese Dioxide) Lithium coin cells. "Perchlorate Material-special handling may apply. See [www.dtsc.ca.gov/hazardouswaste/perchlorate](http://www.dtsc.ca.gov/hazardouswaste/perchlorate)"