

SUPERO[®]

SUPER STORAGE SYSTEM

6037R-E1R16L

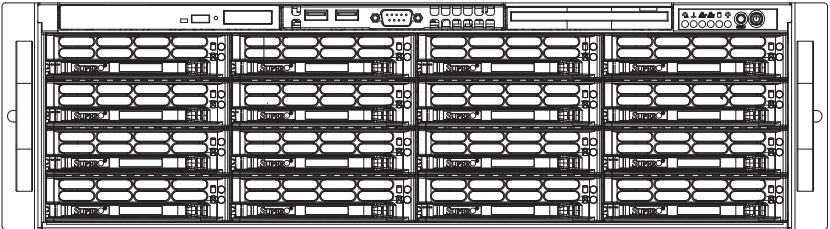

USER'S MANUAL

1.0

The information in this User's Manual has been carefully reviewed and is believed to be accurate. The vendor assumes no responsibility for any inaccuracies that may be contained in this document, makes no commitment to update or to keep current the information in this manual, or to notify any person or organization of the updates. **Please Note: For the most up-to-date version of this manual, please see our web site at www.supermicro.com.**

Super Micro Computer, Inc. ("Supermicro") reserves the right to make changes to the product described in this manual at any time and without notice. This product, including software and documentation, is the property of Supermicro and/or its licensors, and is supplied only under a license. Any use or reproduction of this product is not allowed, except as expressly permitted by the terms of said license.

IN NO EVENT WILL SUPERMICRO BE LIABLE FOR DIRECT, INDIRECT, SPECIAL, INCIDENTAL, SPECULATIVE OR CONSEQUENTIAL DAMAGES ARISING FROM THE USE OR INABILITY TO USE THIS PRODUCT OR DOCUMENTATION, EVEN IF ADVISED OF THE POSSIBILITY OF SUCH DAMAGES. IN PARTICULAR, SUPERMICRO SHALL NOT HAVE LIABILITY FOR ANY HARDWARE, SOFTWARE, OR DATA STORED OR USED WITH THE PRODUCT, INCLUDING THE COSTS OF REPAIRING, REPLACING, INTEGRATING, INSTALLING OR RECOVERING SUCH HARDWARE, SOFTWARE, OR DATA.

Any disputes arising between manufacturer and customer shall be governed by the laws of Santa Clara County in the State of California, USA. The State of California, County of Santa Clara shall be the exclusive venue for the resolution of any such disputes. Super Micro's total liability for all claims will not exceed the price paid for the hardware product.

FCC Statement: This equipment has been tested and found to comply with the limits for a Class A digital device pursuant to Part 15 of the FCC Rules. These limits are designed to provide reasonable protection against harmful interference when the equipment is operated in a commercial environment. This equipment generates, uses, and can radiate radio frequency energy and, if not installed and used in accordance with the manufacturer's instruction manual, may cause harmful interference with radio communications. Operation of this equipment in a residential area is likely to cause harmful interference, in which case you will be required to correct the interference at your own expense.

California Best Management Practices Regulations for Perchlorate Materials: This Perchlorate warning applies only to products containing CR (Manganese Dioxide) Lithium coin cells. "Perchlorate Material-special handling may apply. See www.dtsc.ca.gov/hazardouswaste/perchlorate"

WARNING: Handling of lead solder materials used in this product may expose you to lead, a chemical known to the State of California to cause birth defects and other reproductive harm.

Manual Revision 1.0
Release Date: September 26, 2012

Unless you request and receive written permission from Super Micro Computer, Inc., you may not copy any part of this document.

Information in this document is subject to change without notice. Other products and companies referred to herein are trademarks or registered trademarks of their respective companies or mark holders.

Copyright © 2012 by Super Micro Computer, Inc.
All rights reserved.

Printed in the United States of America

Preface

About This Manual

This manual is written for professional system integrators and PC technicians. It provides information for the installation and use of the 6037R-E1R16L. Installation and maintenance should be performed by experienced technicians only.

The 6037R-E1R16L is a high-end storage system based on the SC836E16-R920B 3U rackmountable chassis and the X9DRD-7LN4F-JBOD dual processor serverboard.

Manual Organization

Chapter 1: Introduction

The first chapter provides a checklist of the main components included with the system and describes the main features of the X9DRD-7LN4F-JBOD serverboard and the SC836E16-R920B chassis.

Chapter 2: Server Installation

This chapter describes the steps necessary to install the 6037R-E1R16L into a rack and check out the server configuration prior to powering up the system. If your server was ordered without processor and memory components, this chapter will refer you to the appropriate sections of the manual for their installation.

Chapter 3: System Interface

Refer here for details on the system interface, which includes the functions and information provided by the control panel on the chassis as well as other LEDs located throughout the system.

Chapter 4: System Safety

You should thoroughly familiarize yourself with this chapter for a general overview of safety precautions that should be followed when installing and servicing the 6037R-E1R16L.

Chapter 5: Advanced Serverboard Setup

Chapter 5 provides detailed information on the X9DRD-7LN4F-JBOD serverboard, including the locations and functions of connections, headers and jumpers. Refer to this chapter when adding or removing processors or main memory and when reconfiguring the serverboard.

Chapter 6: Advanced Chassis Setup

Refer to Chapter 6 for detailed information on the SC836E16-R920B chassis. You should follow the procedures given in this chapter when installing, removing or reconfiguring SATA or peripheral drives and when replacing system power supply units and cooling fans.

Chapter 7: BIOS

The BIOS chapter includes an introduction to BIOS and provides detailed information on running the CMOS Setup Utility.

Appendix A: BIOS Error Beep Codes

Appendix B: System Specifications

Notes

Table of Contents

Chapter 1 Introduction

1-1	Overview	1-1
1-2	Serverboard Features	1-2
	Processors	1-2
	Memory	1-2
	SAS	1-2
	Serial ATA	1-2
	PCI Expansion Slots	1-2
1-3	Server Chassis Features	1-3
	System Power	1-3
	Hard Drives	1-3
	Front Control Panel	1-3
	Cooling System	1-3
1-4	Contacting Supermicro	1-6

Chapter 2 Server Installation

2-1	Overview	2-1
2-2	Unpacking the System	2-1
2-3	Preparing for Setup	2-1
	Choosing a Setup Location	2-1
	Rack Precautions	2-2
	Server Precautions	2-2
	Rack Mounting Considerations	2-3
	Ambient Operating Temperature	2-3
	Reduced Airflow	2-3
	Mechanical Loading	2-3
	Circuit Overloading	2-3
	Reliable Ground	2-3
2-4	Installing the System into a Rack	2-4
	Identifying the Sections of the Rack Rails	2-4
	Installing the Chassis Rails	2-5
	Installing the Server into the Rack	2-6

Chapter 3 System Interface

3-1	Overview	3-1
3-2	Control Panel Buttons	3-1
	Reset	3-1
	Power	3-1

3-3	Control Panel LEDs	3-1
	Power Fail	3-2
	Overheat/Fan Fail	3-2
	NIC1	3-2
	NIC2	3-2
	HDD.....	3-3
	Power	3-3
3-4	Drive Carrier LEDs.....	3-3
Chapter 4 System Safety		
4-1	Electrical Safety Precautions	4-1
4-2	General Safety Precautions	4-2
4-3	ESD Precautions.....	4-3
4-4	Operating Precautions	4-4
Chapter 5 Advanced Serverboard Setup		
5-1	Handling the Serverboard	5-1
	Precautions	5-1
	Unpacking	5-2
5-2	Connecting Cables.....	5-2
	Connecting Data Cables	5-2
	Connecting Power Cables	5-2
	Connecting the Control Panel.....	5-2
5-3	Rear I/O Ports.....	5-3
5-4	Installing the Processor and Heatsink	5-4
	Installing an LGA2011 Processor.....	5-4
	Installing a Passive CPU Heatsink	5-7
	Removing the Heatsink.....	5-8
5-5	Installing Memory	5-9
	Memory Support.....	5-9
	DIMM Installation	5-9
5-6	Adding PCI Add-On Cards.....	5-14
5-7	Serverboard Details	5-15
	X9DRD-7LN4F-JBOD Quick Reference	5-16
5-8	Connector Definitions	5-18
5-9	Jumper Settings	5-25
5-10	Onboard Indicators.....	5-27
5-11	SATA Ports	5-28
5-12	Installing Software.....	5-29
	SuperDoctor III	5-30

Chapter 6 Advanced Chassis Setup

6-1	Static-Sensitive Devices.....	6-1
	Precautions	6-1
	Unpacking	6-1
6-2	Control Panel	6-2
6-3	System Fans	6-3
	System Fan Failure.....	6-3
	Replacing System Fans	6-3
	Rear Exhaust Fans	6-3
6-4	Drive Bay Installation/Removal	6-4
	Accessing the Drive Bays	6-4
	SATA Drive Installation.....	6-5
	Hard Drive Backplane	6-6
	Removing the Air Shroud.....	6-7
	DVD-ROM Installation	6-8
6-5	Power Supply	6-9
	Power Supply Failure.....	6-9
6-6	Attaching a JBOD Expansion Chassis.....	6-10

Chapter 7 BIOS

7-1	Introduction.....	7-1
	Starting BIOS Setup Utility.....	7-1
	How To Change the Configuration Data	7-2
	Starting the Setup Utility	7-2
7-2	Main Setup	7-2
7-3	Advanced Setup Configurations.....	7-4
7-4	Event Logs	7-25
7-5	IPMI.....	7-27
7-6	Boot.....	7-29
7-7	Security	7-30
7-8	Save & Exit	7-31

Appendix A BIOS Error Beep Codes**Appendix B System Specifications**

Chapter 1

Introduction

1-1 Overview

The 6037R-E1R16L is a high-end storage system comprised of two main subsystems: the SC836E16-R920B 3U/rack mount chassis and the X9DRD-7LN4F-JBOD dual processor serverboard. Please refer to our web site for information on operating systems that have been certified for use with the system (www.supermicro.com).

In addition to the serverboard and chassis, various hardware components have been included with the 6037R-E1R16L, as listed below:

- Two passive CPU heatsinks (SNK-P0048PS)
- Three 8-cm system fans (FAN-0126L4)
- Two rear exhaust fans (FAN-0125L4)
- One air shroud (MCP-310-39001-0N)
- SATA Accessories
 - One SATA backplane (BPN-SAS2-836EL1)
 - Sixteen drive carriers (MCP-220-00075-OB)
 - JBOD Expansion Port (CBL-0352L)
- One rackmount kit (MCP-290-00053-0N)
- One CD containing drivers and utilities

Note: a complete list of safety warnings is provided on the Supermicro web site at http://www.supermicro.com/about/policies/safety_information.cfm

1-2 Serverboard Features

The 6047R-E1R24L is built around the X9DRD-7LN4F-JBOD, a dual processor serverboard based on the Intel C602J chipset. Below are the main features of the X9DRD-7LN4F-JBOD. (See Figure 1-1 for a block diagram of the chipset).

Processors

The X9DRD-7LN4F-JBOD supports single or dual Intel® Xeon E5-2600 Series processors. Please refer to the serverboard description pages on our web site for a complete listing of supported processors (www.supermicro.com).

Memory

The X9DRD-7LN4F-JBOD has 16 DIMM slots that can support 512 GB of ECC DDR3 Registered memory (RDIMM) or up to 128 GB of ECC/non-ECC DDR3 Unbuffered memory (UDIMM). See Chapter 5 for details.

SAS

A SAS 2.0 controller is integrated into the serverboard providing 8x lanes of 6Gb/s SAS with basic HBA/ITMode controller functionality. The controller supports the attachment of 122 SAS or SATA devices.

Serial ATA

A SATA controller is also integrated into the chipset to provide two SATA 3 (6Gbps) and four SATA 2 (3 Gbps) ports, which are RAID 0, 1, 5 and 10 supported. The SATA drives are hot-swappable units.

PCI Expansion Slots

The X9DRD-7LN4F-JBOD has six PCI-E 3.0 x8 slots. The default configuration includes a port plate with dual JBOD expansion ports occupying slot #1 (PCI-E 3.0 x8). Note that expansion slots are controlled by the CPUs, so two CPUs need to be installed to enable all PCI expansion slots. See Chapter 5 for details.

1-3 Server Chassis Features

The following is a general outline of the main features of the SC836E16-R920B server chassis.

System Power

The SC836E16-R920B features a redundant (two separate power modules) 920W high-efficiency power supply with I²C. This power redundancy feature allows you to replace a failed power supply without shutting down the system.

Hard Drives

The SC836E16-R920B chassis was designed to support sixteen dual-channel SATA hard drives, which are hot-swappable units. 2x 2.5" rear mounted hot-swap drive bays are available as an option for use with the onboard SATA controller (MCP-220-83605-0N).

Note: The operating system you use must have RAID support to enable the hot-swap capability of the SATA drives.

Front Control Panel

The control panel on the SuperServer 6037R-E1R16L provides you with system monitoring and control. LEDs indicate system power, HDD activity, network activity, system overheat and power supply failure. A main power button and a system reset button are also included. In addition, two USB ports and a COM port have been incorporated into the front of the chassis for convenient access.

Cooling System

The SC836E16-R920B chassis includes three 8-cm hot-plug system cooling fans located in the middle section of the chassis. An air shroud channels the airflow from the system fans to efficiently cool the processors and memory. Two additional 8-cm fans are located at the back of the chassis to expel hot air from the system. Each power supply module also include a cooling fan.

**Figure 1-1. Intel C602J Chipset:
System Block Diagram**

Note: This is a general block diagram. Please see Chapter 5 for details.

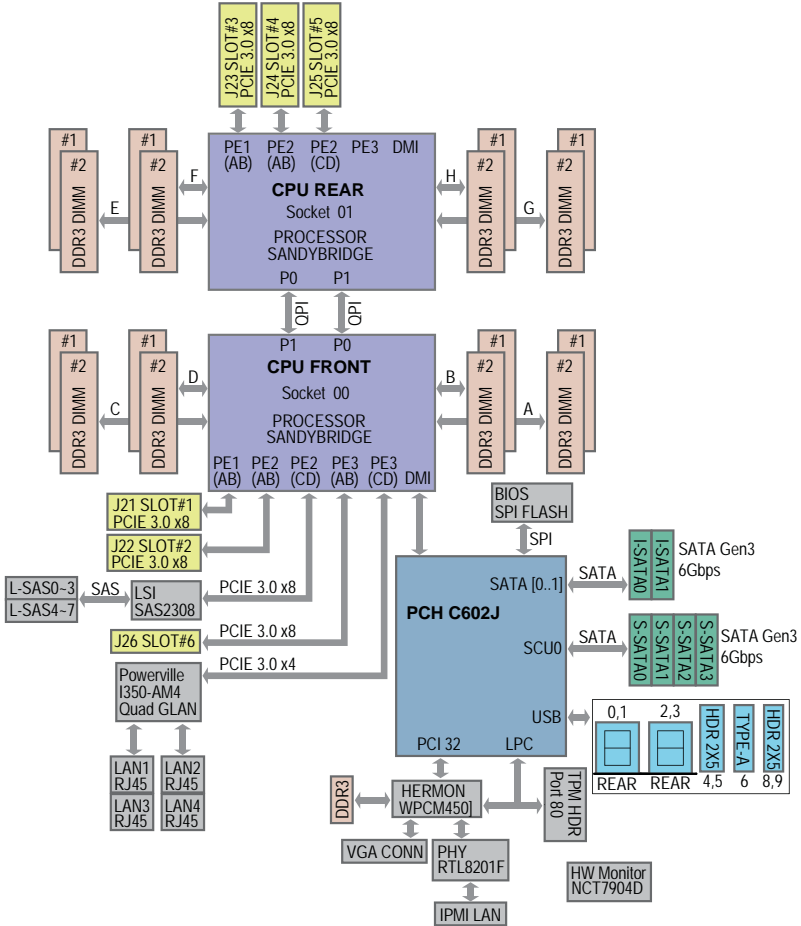
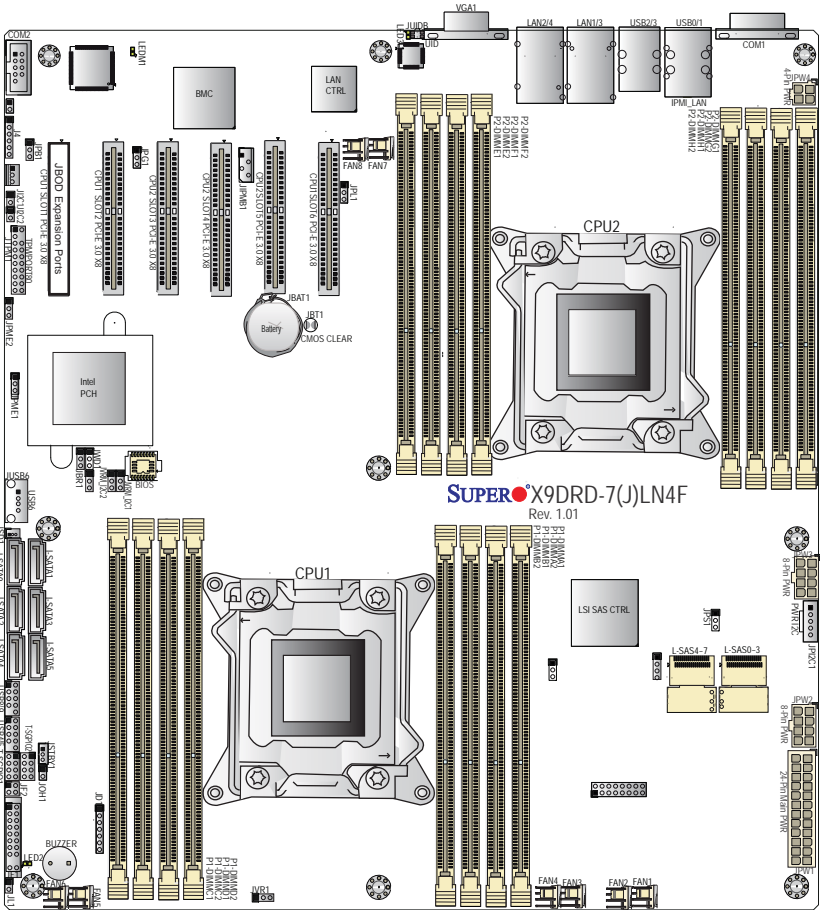

Figure 1-2. X9DRD-7LN4F-JBOD Serverboard



Note: The SSG-6047R-E1R24L comes pre-installed with a JBOD expansion port installed in PCI-E slot 1. Serverboard SAS components shown in the figure above are not included on the X9DRD-7LN4F-JBOD

1-4 Contacting Supermicro

Headquarters

Address: Super Micro Computer, Inc.
980 Rock Ave.
San Jose, CA 95131 U.S.A.

Tel: +1 (408) 503-8000

Fax: +1 (408) 503-8008

Email: marketing@supermicro.com (General Information)
support@supermicro.com (Technical Support)

Web Site: www.supermicro.com

Europe

Address: Super Micro Computer B.V.
Het Sterrenbeeld 28, 5215 ML
's-Hertogenbosch, The Netherlands

Tel: +31 (0) 73-6400390

Fax: +31 (0) 73-6416525

Email: sales@supermicro.nl (General Information)
support@supermicro.nl (Technical Support)
rma@supermicro.nl (Customer Support)

Asia-Pacific

Address: Super Micro Computer, Inc.
4F, No. 232-1, Liancheng Rd.
Chung-Ho Dist., New Taipei City 235
Taiwan

Tel: +886-(2) 8226-3990

Fax: +886-(2) 8226-3991

Web Site: www.supermicro.com.tw

Technical Support:

Email: support@supermicro.com.tw

Tel: 886-2-8228-1366, ext.132 or 139

Chapter 2

Server Installation

2-1 Overview

This chapter provides a quick setup checklist to get your SuperServer 6037R-E1R16L up and running. Following these steps in the order given should enable you to have the system operational within a minimum amount of time. This quick setup assumes that your system has come to you with the processors and memory preinstalled. If your system is not already fully integrated with a serverboard, processors, system memory etc., please turn to the chapter or section noted in each step for details on installing specific components.

2-2 Unpacking the System

You should inspect the box the SuperServer 6037R-E1R16L was shipped in and note if it was damaged in any way. If the server itself shows damage you should file a damage claim with the carrier who delivered it.

Decide on a suitable location for the rack unit that will hold the SuperServer 6037R-E1R16L. It should be situated in a clean, dust-free area that is well ventilated. Avoid areas where heat, electrical noise and electromagnetic fields are generated. You will also need it placed near a grounded power outlet. Read the Rack and Server Precautions in the next section.

2-3 Preparing for Setup

The box the SuperServer 6037R-E1R16L was shipped in should include two sets of rail assemblies, two rail mounting brackets and the mounting screws you will need to install the system into the rack. Follow the steps in the order given to complete the installation process in a minimum amount of time. Please read this section in its entirety before you begin the installation procedure outlined in the sections that follow.

Choosing a Setup Location

- Leave enough clearance in front of the rack to enable you to open the front door completely (~25 inches) and approximately 30 inches of clearance in the back of the rack to allow for sufficient airflow and ease in servicing.
 - This product is for installation only in a Restricted Access Location (dedicated equipment rooms, service closets and the like).
-

- This product is not suitable for use with visual display work place devices according to §2 of the the German Ordinance for Work with Visual Display Units.



Warnings and Precautions!



Rack Precautions

- Ensure that the leveling jacks on the bottom of the rack are fully extended to the floor with the full weight of the rack resting on them.
- In single rack installation, stabilizers should be attached to the rack. In multiple rack installations, the racks should be coupled together.
- Always make sure the rack is stable before extending a component from the rack.
- You should extend only one component at a time - extending two or more simultaneously may cause the rack to become unstable.

Server Precautions

- Review the electrical and general safety precautions in Chapter 4.
- Determine the placement of each component in the rack *before* you install the rails.
- Install the heaviest server components on the bottom of the rack first, and then work up.
- Use a regulating uninterruptible power supply (UPS) to protect the server from power surges, voltage spikes and to keep your system operating in case of a power failure.
- Allow any hot plug drives and power supply modules to cool before touching them.
- Always keep the rack's front door and all panels and components on the servers closed when not servicing to maintain proper cooling.

Rack Mounting Considerations

Ambient Operating Temperature

If installed in a closed or multi-unit rack assembly, the ambient operating temperature of the rack environment may be greater than the ambient temperature of the room. Therefore, consideration should be given to installing the equipment in an environment compatible with the manufacturer's maximum rated ambient temperature (T_{mra}).

Reduced Airflow

Equipment should be mounted into a rack so that the amount of airflow required for safe operation is not compromised.

Mechanical Loading

Equipment should be mounted into a rack so that a hazardous condition does not arise due to uneven mechanical loading.

Circuit Overloading

Consideration should be given to the connection of the equipment to the power supply circuitry and the effect that any possible overloading of circuits might have on overcurrent protection and power supply wiring. Appropriate consideration of equipment nameplate ratings should be used when addressing this concern.

Reliable Ground

A reliable ground must be maintained at all times. To ensure this, the rack itself should be grounded. Particular attention should be given to power supply connections other than the direct connections to the branch circuit (i.e. the use of power strips, etc.).

2-4 Installing the System into a Rack

This section provides information on installing the SuperServer 6037R-E1R16L into a rack unit. If the 6037R-E1R16L has already been mounted into a rack, you can skip ahead to Sections 2-5 and 2-6. There are a variety of rack units on the market, which may mean the assembly procedure will differ slightly. The following is a guideline for installing the 6037R-E1R16L into a rack with the rack rails provided. You should also refer to the installation instructions that came with the rack unit you are using.

Identifying the Sections of the Rack Rails

You should have received two rack rail assemblies with the SuperServer 6037R-E1R16L. Each of these assemblies consist of two sections: an inner chassis rail that secures to the chassis (A) and an outer rack rail that secures directly to the rack itself (B). All screws and hardware mentioned in the installation steps should be included in the hardware kit.

To remove the chassis rail (A), pull it out as far as possible - you should hear a "click" sound as a locking tab emerges from inside the rail assembly and locks the inner rail. Then depress the locking tab to pull the inner rail completely out. Do this for both the left and right side rack rail assemblies.

Figure 2-1. Identifying the Sections of the Rack Rails

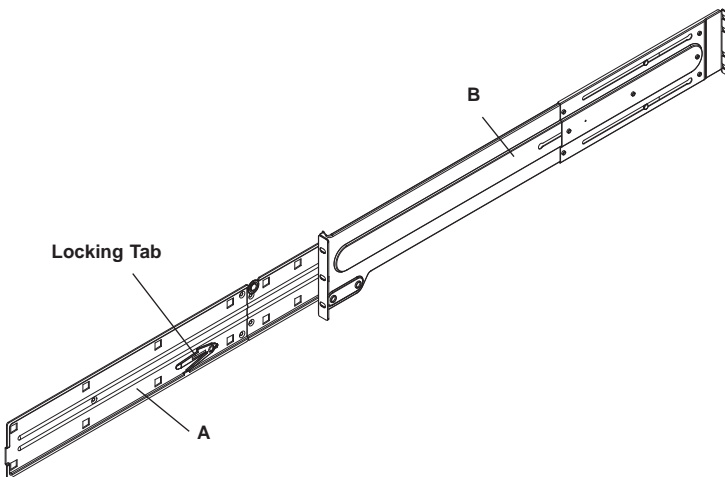

Installing the Chassis Rails

Position one of the chassis rail sections you just removed along the side of the 6037R-E1R16L. Note that the two chassis rails are left/right specific. Locate the numerous rail tabs on each side of the chassis and the corresponding holes on each of the chassis rails. Note that the holes are elongated with one end of the hole larger than the other. Align the larger end of each hole with its corresponding tab. With all holes and tabs aligned, position the rail onto the side of the chassis (see Figure 2-2). Once a rail is positioned on the chassis, pull it forward until the rail tabs lock in the small ends of the corresponding holes. Then secure the rail to the chassis with the screws included in the hardware kit. Repeat the above steps to install the other rail on the chassis.

Locking Tabs: As mentioned, both chassis rails have locking tabs, which serve to lock the server into place when installed and pushed fully into the rack (its normal position).

Figure 2-2. Installing Chassis Rails

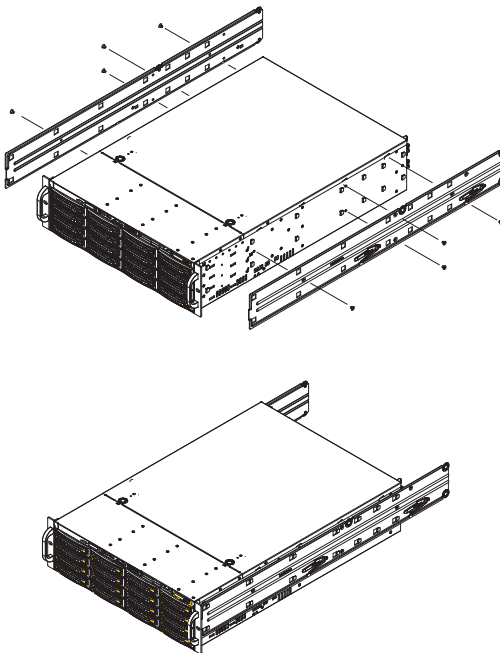

Installing the Server into the Rack

Locate the front and rear brackets that on both ends of the outer chassis rail. These brackets sit perpendicular to the rail and are used to attached the rail to the rack. Secure the front bracket to the rack with two screws and the rear bracket to the rack with four screws using the appropriate screws and washers included in the hardware kit (see Figure 2-3). You may need to adjust the rail to match the depth of the rack. Repeat the same steps to install the other outer rail to the rack.

You are now ready to install the server into the rack. Slide the chassis into the rack as shown in Figure 2-4. The chassis may not slide into the rack smoothly or easily when installed the first time. Some adjustment to the slide assemblies might be needed for easier installation.

When the server has been pushed completely into the rack, you should hear the locking tabs "click". You'll need to release the safety taps on both sides of the chassis in order to completely remove the chassis out of the rack.

Figure 2-3. Assembling the Rack Rails

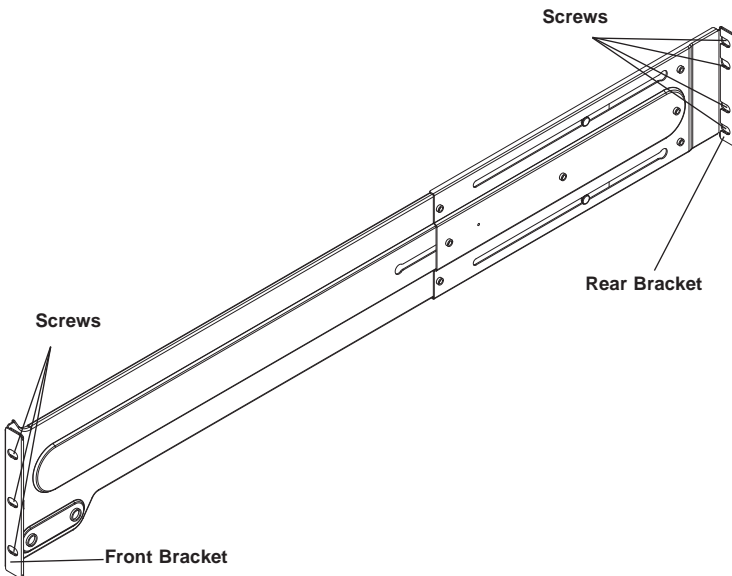
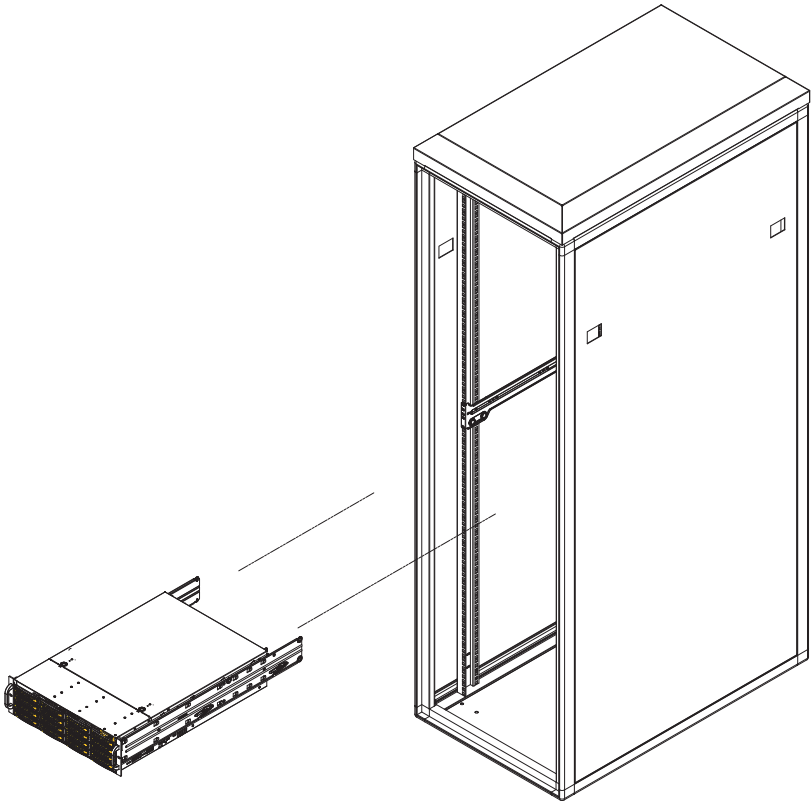

Figure 2-4. Installing the Server into a Rack



Notes

Chapter 3

System Interface

3-1 Overview

There are several LEDs on the control panel as well as others on the hard drive carriers to keep you constantly informed of the overall status of the system as well as the activity and health of specific components. There are also two buttons on the chassis control panel.

3-2 Control Panel Buttons

The two push-buttons located on the front of the chassis are (in order from left to right) a reset button and a power on/off button.

RESET



Reset

Use the reset button to reboot the system.



Power

This is the main power button, which is used to apply or turn off the main system power. Turning off system power with this button removes the main power but keeps standby power supplied to the system.

3-3 Control Panel LEDs

The control panel located on the front of the chassis has several LEDs. These LEDs provide you with critical information related to different parts of the system. This section explains what each LED indicates when illuminated and any corrective action you may need to take.



Power Fail

Indicates a power supply module has failed. The second power supply module will take the load and keep the system running but the failed module will need to be replaced. Refer to Chapter 6 for details on replacing the power supply. This LED should be off when the system is operating normally.



Overheat/Fan Fail

When this LED flashes, it indicates a fan failure. When on continuously it indicates an overheat condition, which may be caused by cables obstructing the airflow in the system or the ambient room temperature being too warm. Check the routing of the cables and make sure all fans are present and operating normally. You should also check to make sure that the chassis covers are installed. Finally, verify that the heatsinks are installed properly (see Chapter 5). This LED will remain flashing or on as long as the indicated condition exists.



NIC1

Indicates network activity on the JLAN1 port when flashing.



NIC2

Indicates network activity on the JLAN2 port when flashing.



HDD

Indicates IDE channel activity. On the SuperServer 6037R-E1R16L, this LED indicates hard and/or DVD-ROM drive activity when flashing.



Power

Indicates power is being supplied to the system's power supply units. This LED should normally be illuminated when the system is operating.

3-4 Drive Carrier LEDs

Each drive carrier has two LEDs.

- **Green:** When illuminated, the green LED on the front of the drive carrier indicates drive activity. A connection to the backplane enables this LED to blink on and off when that particular drive is being accessed.
- **Red:** The SAF-TE compliant backplane activates the red LED to indicate a drive failure. If one of the drives fail, you should be notified by your system management software. Please refer to Chapter 6 for instructions on replacing failed drives.

Notes

Chapter 4

System Safety

4-1 Electrical Safety Precautions



Basic electrical safety precautions should be followed to protect yourself from harm and the SuperServer 6037R-E1R16L from damage:

- Be aware of the locations of the power on/off switch on the chassis as well as the room's emergency power-off switch, disconnection switch or electrical outlet. If an electrical accident occurs, you can then quickly remove power from the system.
- Do not work alone when working with high voltage components.
- Power should always be disconnected from the system when removing or installing main system components, such as the serverboard, memory modules and floppy drive. When disconnecting power, you should first power down the system with the operating system first and then unplug the power cords of all the power supply units in the system.
- When working around exposed electrical circuits, another person who is familiar with the power-off controls should be nearby to switch off the power if necessary.
- Use only one hand when working with powered-on electrical equipment. This is to avoid making a complete circuit, which will cause electrical shock. Use extreme caution when using metal tools, which can easily damage any electrical components or circuit boards they come into contact with.
- Do not use mats designed to decrease static electrical discharge as protection from electrical shock. Instead, use rubber mats that have been specifically designed as electrical insulators.
- The power supply power cords must include a grounding plug and must be plugged into grounded electrical outlets.

- Serverboard Battery: **CAUTION** - There is a danger of explosion if the onboard battery is installed upside down, which will reverse its polarities (see Figure 4-1). This battery must be replaced only with the same or an equivalent type recommended by the manufacturer (CR2032). Dispose of used batteries according to the manufacturer's instructions.
- DVD-ROM Laser: **CAUTION** - this server may have come equipped with a DVD-ROM drive. To prevent direct exposure to the laser beam and hazardous radiation exposure, do not open the enclosure or use the unit in any unconventional way.
- Mainboard replaceable soldered-in fuses: Self-resetting PTC (Positive Temperature Coefficient) fuses on the mainboard must be replaced by trained service technicians only. The new fuse must be the same or equivalent as the one replaced. Contact technical support for details and support.

4-2 General Safety Precautions



Follow these rules to ensure general safety:

- Keep the area around the 6037R-E1R16L clean and free of clutter.
- The 6037R-E1R16L weighs approximately 75 lbs (34.1 kg.) when fully loaded. When lifting the system, two people at either end should lift slowly with their feet spread out to distribute the weight. Always keep your back straight and lift with your legs.
- Place the chassis top cover and any system components that have been removed away from the system or on a table so that they won't accidentally be stepped on.
- While working on the system, do not wear loose clothing such as neckties and unbuttoned shirt sleeves, which can come into contact with electrical circuits or be pulled into a cooling fan.
- Remove any jewelry or metal objects from your body, which are excellent metal conductors that can create short circuits and harm you if they come into contact with printed circuit boards or areas where power is present.

- After accessing the inside of the system, close the system back up and secure it to the rack unit with the retention screws after ensuring that all connections have been made.

4-3 ESD Precautions



Electrostatic discharge (ESD) is generated by two objects with different electrical charges coming into contact with each other. An electrical discharge is created to neutralize this difference, which can damage electronic components and printed circuit boards. The following measures are generally sufficient to neutralize this difference before contact is made to protect your equipment from ESD:

- Use a grounded wrist strap designed to prevent static discharge.
- Keep all components and printed circuit boards (PCBs) in their antistatic bags until ready for use.
- Touch a grounded metal object before removing the board from the antistatic bag.
- Do not let components or PCBs come into contact with your clothing, which may retain a charge even if you are wearing a wrist strap.
- Handle a board by its edges only; do not touch its components, peripheral chips, memory modules or contacts.
- When handling chips or modules, avoid touching their pins.
- Put the serverboard and peripherals back into their antistatic bags when not in use.
- For grounding purposes, make sure your computer chassis provides excellent conductivity between the power supply, the case, the mounting fasteners and the serverboard.

4-4 Operating Precautions



Care must be taken to assure that the chassis cover is in place when the 6037R-E1R16L is operating to assure proper cooling. Out of warranty damage to the system can occur if this practice is not strictly followed.

Figure 4-1. Installing the Onboard Battery

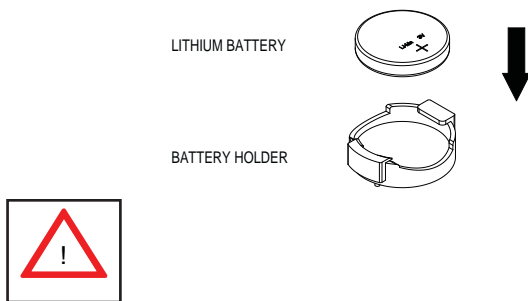

Please handle used batteries carefully. Do not damage the battery in any way; a damaged battery may release hazardous materials into the environment. Do not discard a used battery in the garbage or a public landfill. Please comply with the regulations set up by your local hazardous waste management agency to dispose of your used battery properly.

Note: a complete list of safety warnings is provided on the Supermicro web site at http://super-dev/about/policies/safety_information.cfm

Chapter 5

Advanced Serverboard Setup

This chapter covers the steps required to connect the data and power cables and install add-on cards. All serverboard jumpers and connections are also described. A layout and quick reference chart are included in this chapter for your reference. Remember to completely close the chassis when you have finished working with the serverboard to better cool and protect the system.

5-1 Handling the Serverboard

Electrostatic Discharge (ESD) can damage electronic components. To prevent damage to any printed circuit boards (PCBs), it is important to handle them very carefully (see previous chapter). To prevent the serverboard from bending, keep one hand under the center of the board to support it when handling. The following measures are generally sufficient to protect your equipment from electric static discharge.

Precautions

- Use a grounded wrist strap designed to prevent Electrostatic Discharge (ESD).
- Touch a grounded metal object before removing any board from its antistatic bag.
- Handle a board by its edges only; do not touch its components, peripheral chips, memory modules or gold contacts.
- When handling chips or modules, avoid touching their pins.
- Put the serverboard, add-on cards and peripherals back into their antistatic bags when not in use.
- For grounding purposes, make sure your computer chassis provides excellent conductivity between the power supply, the case, the mounting fasteners and the serverboard.

Unpacking

The serverboard is shipped in antistatic packaging to avoid electrical static discharge. When unpacking the board, make sure the person handling it is static protected.

5-2 Connecting Cables

Several cables need to be connected to the serverboard. These include the data cables for the peripherals and control panel and the power cables.

Connecting Data Cables

The cables used to transfer data from the peripheral devices have been carefully routed to prevent them from blocking the flow of cooling air that moves through the system from front to back. If you need to disconnect any of these cables, you should take care to keep them routed as they were originally after reconnecting them (make sure the red wires connect to the pin 1 locations). The following data cables (with their locations noted) should be connected. (See the layout on page 5-10 for connector locations.)

- Control Panel cable (JF1)
- USB cable for front side access (USB4/5)

Important! Make sure the the cables do not come into contact with the fans.

Connecting Power Cables

The X9DRD-7LN4F-JBOD has a 24-pin primary power supply connector (JPW1) for connection to the ATX power supply. In addition, there are two 8-pin 12V processor power connectors (JPW2 and JPW3) that must be connected to your power supply. See Section 5-9 for power connector pin definitions.

Connecting the Control Panel

JF1 contains header pins for various front control panel connectors. See Figure 5-1 for the pin locations of the various front control panel buttons and LED indicators.

All JF1 wires have been bundled into a single cable to simplify this connection. Make sure the red wire plugs into pin 1 as marked on the board. The other end connects to the Control Panel PCB board, located just behind the system status LEDs on the chassis. See Chapter 5 for details and pin descriptions.

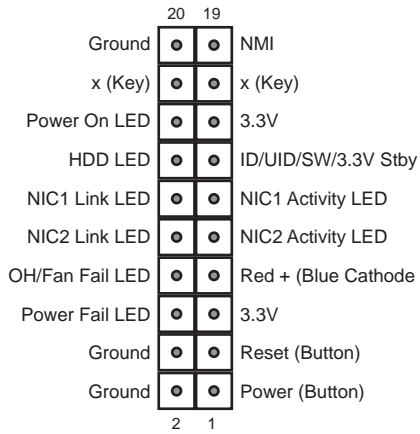
Figure 5-1. Control Panel Header Pins

5-3 Rear I/O Ports

The I/O ports are color coded in conformance with the PC 99 specification. See Figure 5-2 below for the colors and locations of the various I/O ports.

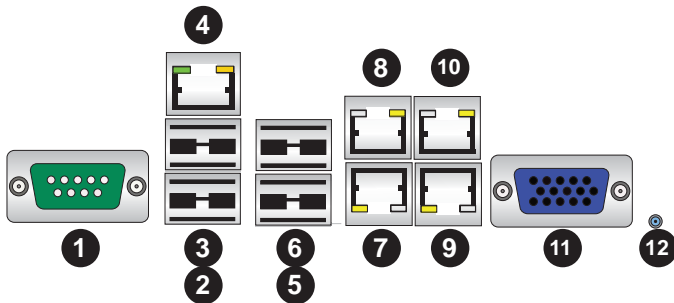
Figure 5-2. Rear I/O Ports

Rear I/O Ports	
1	COM Port 1
2	USB Port 0
3	USB Port 1
4	Dedicated IPMI LAN
5	USB Port 2
6	USB Port 3
7	LAN Port 1
8	LAN Port 2
9	LAN Port 3
10	LAN Port 4
11	VGA Port
12	UID Switch

5-4 Installing the Processor and Heatsink



When handling the processor package, avoid placing direct pressure on the label area of the fan.

Notes:

- Always connect the power cord last and always remove it before adding, removing or changing any hardware components. Make sure that you install the processor into the CPU socket before you install the CPU heatsink.
- If you buy a CPU separately, make sure that you use an Intel-certified multi-directional heatsink only.
- Make sure to install the serverboard into the chassis before you install the CPU heatsinks.
- When receiving a serverboard without a processor pre-installed, make sure that the plastic CPU socket cap is in place and none of the socket pins are bent; otherwise, contact your retailer immediately.
- Refer to the Supermicro web site for updates on CPU support.

Installing an LGA2011 Processor

1. There are two levers on the LGA2011 socket. First press and release the load lever labeled 'Open 1st'.
2. Press the second load lever labeled 'Close 1st' to release the load plate from its locked position.

Press down on the lever labeled
'Close 1st'

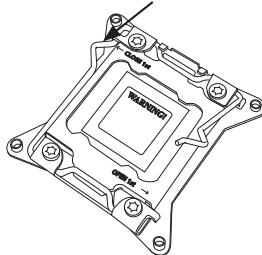

Pull lever away
from the socket

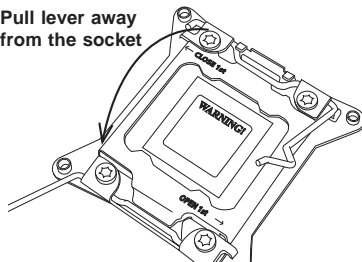

3. With the lever labeled 'Close 1st' fully retracted, gently push down on the 'Open 1st' lever to open the load plate. Lift the load plate to open it completely.
4. Using your thumb and the index finger, remove the 'WARNING' plastic cap from the socket.
5. Use your thumb and index finger to hold the CPU by its edges. Align the CPU keys, which are semi-circle cutouts, against the socket keys.
6. Once they are aligned, carefully lower the CPU straight down into the socket. (Do not drop the CPU on the socket. Do not move the CPU horizontally or vertically and do not rub the CPU against any pins of the socket, which may damage the CPU or the socket.)

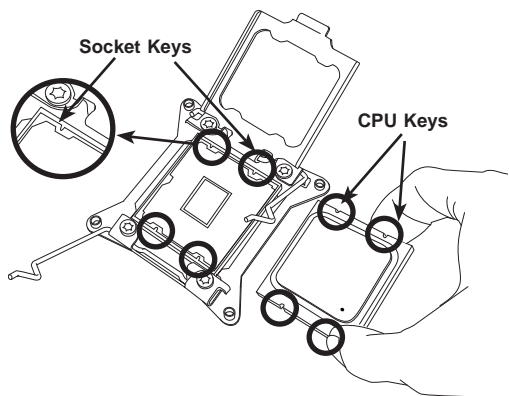
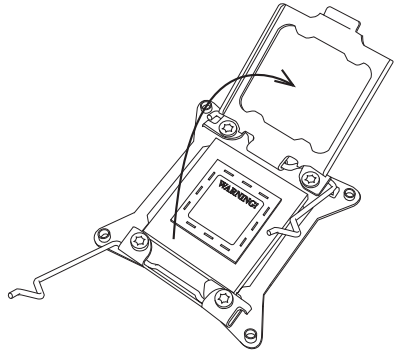
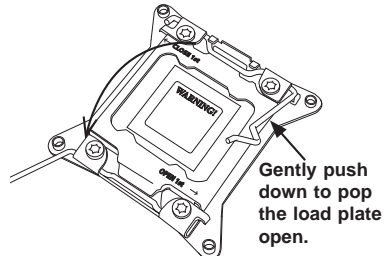



Warning: You can only install the CPU to the socket in one direction. Make sure that the CPU is properly inserted into the socket before closing the load plate. If it doesn't close properly, do not force it as it may damage your CPU. Instead, open the load plate again and double-check that the CPU is aligned properly.

7. With the CPU in the socket, inspect the four corners of the CPU to make sure that they are flush with the socket.

8. Close the load plate. Lock the lever labeled 'Close 1st', then lock the lever labeled 'Open 1st'. Use your thumb to gently push the load levers down until the lever locks.

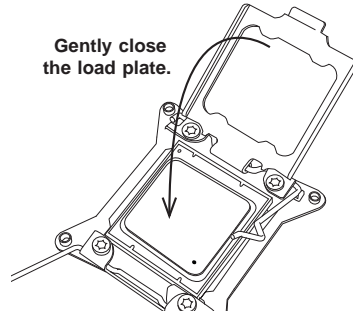

Push down and lock the level labeled 'Close 1st'.

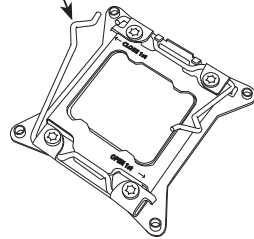

Lever Lock

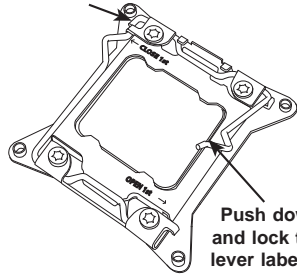

Installing a Passive CPU Heatsink

1. Do not apply any thermal grease to the heatsink or the CPU die -- the required amount has already been applied.
2. Place the heatsink on top of the CPU so that the four mounting holes are aligned with those on the Serverboard's and the Heatsink Bracket underneath.
3. Screw in two diagonal screws (i.e., the #1 and the #2 screws) until just snug (-do not over-tighten the screws to avoid possible damage to the CPU.)
4. Finish the installation by fully tightening all four screws.

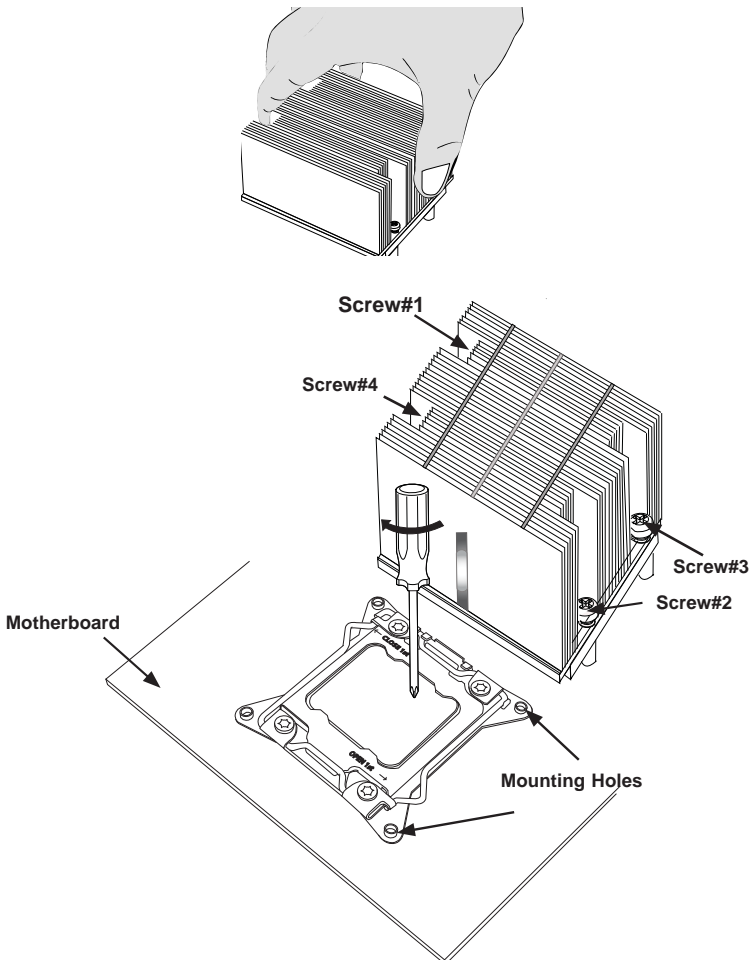

Removing the Heatsink



Warning: We do not recommend that the CPU or the heatsink be removed. However, if you do need to uninstall the heatsink, please follow the instructions below to uninstall the heatsink to prevent damage done to the CPU or the CPU socket.

1. Unscrew the heatsink screws from the serverboard in the sequence as shown in the illustration below.
2. Gently wriggle the heatsink to loosen it from the CPU. (Do not use excessive force when wriggling the heatsink!)
3. Once the heatsink is loosened, remove it from the CPU.
4. Remove the used thermal grease and clean the surface of the CPU and the heatsink, Reapply the proper amount of thermal grease on the surface before reinstalling the heatsink. (Do not reuse old thermal grease!)

Loosen screws
in sequence as
shown.

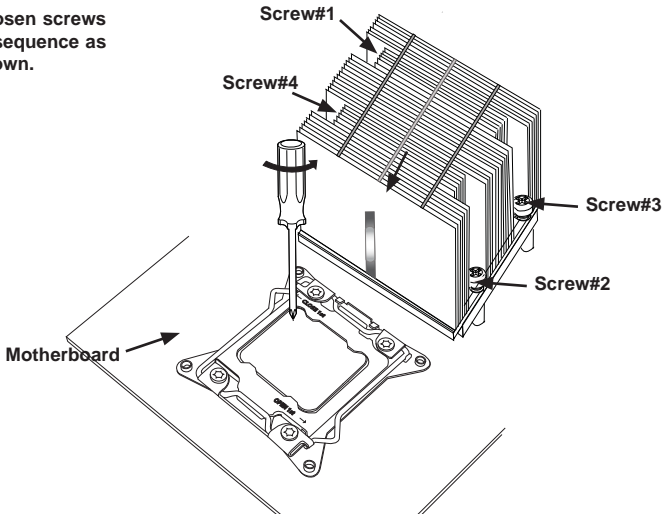

Warning: Do not reuse old thermal grease!

5-5 Installing Memory



CAUTION! Exercise extreme care when installing or removing DIMM modules to prevent any possible damage.

Memory Support

The X9DRD-7LN4F-JBOD has 16 DIMM slots that can support 512 GB of ECC DDR3 Registered memory (RDIMM) or up to 128 GB of ECC/non-ECC DDR3 Unbuffered memory (UDIMM). For best performance, install pairs of memory modules of the same type and speed. Please refer to our web site for any updates to supported memory. All channels will run at the fastest common frequency.

DIMM Installation

Installing Memory Modules

1. Insert the desired number of DIMMs into the memory slots starting with P1-DIMMA1. See the Memory Installation Tables on the following pages.
2. Insert each DIMM module vertically into its slot. Pay attention to the notch along the bottom of the module to avoid installing incorrectly (see Figure 5-3).
3. Use your thumbs to gently press down on both ends of the DIMM module until it snaps into place in the slot. Repeat for all modules.
4. Press the release tabs to the locked positions to secure the DIMM module into the slot.

To Install: Insert module vertically and press down until it snaps into place. Pay attention to the alignment notch at the bottom.

To Remove: Use your thumbs to gently push the release tabs near both ends of the module. This should release it from the slot.

Figure 5-3. DIMM Installation

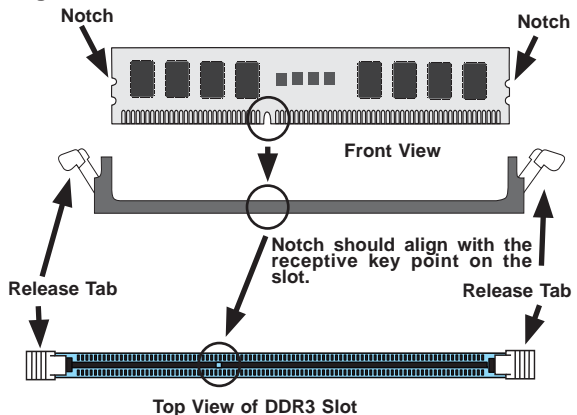

DIMM Module Population Tables

Processors and their Corresponding Memory Modules								
CPU#	Corresponding DIMM Modules							
CPU 1	P1-DIMMA1	P1-DIMMB1	P1-DIMMC1	P1-DIMMD1	P1-DIMMA2	P1-DIMMB2	P1-DIMMC2	P1-DIMMD2
CPU2	P2-DIMME1	P2-DIMMF1	P2-DIMMG1	P2-DIMMH1	P2-DIMME2	P2-DIMM F2	P2-DIMMG2	P2-DIMMH2

Processor and Memory Module Population for Optimal Performance	
Number of CPUs+DIMMs	CPU and Memory Population Configuration Table (For memory to work properly, please follow the instructions below.)
1 CPU & 2 DIMMs	CPU1 P1-DIMMA1/P1-DIMMB1
1 CPU & 4 DIMMs	CPU1 P1-DIMMA1/P1-DIMMB1, P1-DIMMC1/P1-DIMMD1
1 CPU & 5-8 DIMMs	CPU1 P1-DIMMA1/P1-DIMMB1, P1-DIMMC1/P1-DIMMD1 + Any memory pairs in P1-DIMMA2/P1-DIMMB2/P1-DIMMC2/P1-DIMMD2 slots
2 CPUs & 4 DIMMs	CPU1 + CPU2 P1-DIMMA1/P1-DIMMB1, P2-DIMME1/P2-DIMMF1
2 CPUs & 6 DIMMs	CPU1 + CPU2 P1-DIMMA1/P1-DIMMB1/P1-DIMMC1/P1-DIMMD1, P2-DIMME1/P2-DIMMF1
2 CPUs & 8 DIMMs	CPU1 + CPU2 P1-DIMMA1/P1-DIMMB1/P1-DIMMC1/P1-DIMMD1, P2-DIMME1/P2-DIMMF1/P2-DIMMG1/P2-DIMMH1
2 CPUs & 10-16 DIMMs	CPU1/CPU2 P1-DIMMA1/P1-DIMMB1/P1-DIMMC1/P1-DIMMD1, P2-DIMME1/P2-DIMMF1/P2-DIMMG1/P2-DIMMH1 + Any memory pairs in P1, P2 DIMM slots
2 CPUs & 16 DIMMs	CPU1/CPU2 P1-DIMMA1/P1-DIMMB1/P1-DIMMC1/P1-DIMMD1, P2-DIMME1/P2-DIMMF1/P2-DIMMG1/P2-DIMMH1, P1-DIMMA2/P1-DIMMB2/P1-DIMMC2/P1-DIMMD2, P2-DIMME2/P2-DIMMF2/P2-DIMMG2/P2-DIMMH2

Intel E5-2600 Series Processor UDIMM Memory Support									
Ranks Per DIMM & Data Width	Memory Capacity Per DIMM (See the Note below)			Speed (MT/s) and Voltage Validated by Slot per Channel (SPC) and DIMM Per Channel (DPC)					
				1 Slot Per Channel		2 Slots Per Channel			
	1DPC		1DPC		2DPC				
	1.35V	1.5V	1.35V	1.5V	1.35V	1.5V	1.35V	1.5V	
SRx8 Non-ECC	1GB	2GB	4GB	NA	1066, 1333, 1600	NA	1066, 1333	NA	1066, 1333
DRx8 Non-ECC	2GB	4GB	8GB	NA	1066, 1333, 1600	NA	1066, 1333	NA	1066, 1333
SRx16 Non-ECC	512MB	1GB	2GB	NA	1066, 1333, 1600	NA	1066, 1333	NA	1066, 1333
SRx8 ECC	1GB	2GB	4GB	1066, 1333	1066, 1333, 1600	1066, 1333	1066, 1333	1066	1066, 1333
DRx8 ECC	2GB	4GB	8GB	1066, 1333	1066, 1333, 1600	1066, 1333	1066, 1333	1066	1066, 1333

Note: For detailed information on memory support and updates, please refer to the SMC Recommended Memory List posted on our website at <http://www.supernano.com/support/resources/mem.cfm>.

Intel E5-2600 Series Processor RDIMM Memory Support									
Ranks Per DIMM & Data Width	Memory Capacity Per DIMM (See the Note Below)			Speed (MT/s) and Voltage Validated by Slot per Channel (SPC) and DIMM Per Channel (DPC)					
				1 Slot Per Channel		2 Slots Per Channel			
				1DPC		1DPC		2DPC	
				1.35V	1.5V	1.35V	1.5V	1.35V	1.5V
SRx8	1GB	2GB	4GB	1066, 1333	1066, 1333, 1600	1066, 1333	1066, 1333, 1600	1066, 1333	1066, 1333, 1600
DRx8	2GB	4GB	8GB	1066, 1333	1066, 1333, 1600	1066, 1333	1066, 1333, 1600	1066, 1333	1066, 1333, 1600
SRx4	2GB	4GB	8GB	1066, 1333	1066, 1333, 1600	1066, 1333	1066, 1333, 1600	1066, 1333	1066, 1333, 1600
DRx4	4GB	8GB	16GB	1066, 1333	1066, 1333, 1600	1066, 1333	1066, 1333, 1600	1066, 1333	1066, 1333, 1600
QRx4	8GB	16GB	32GB	800	1066	800	1066	800	800
QRx8	4GB	8GB	16GB	800	1066	800	1066	800	800

Note: For detailed information on memory support and updates, please refer to the SMC Recommended Memory List posted on our website at <http://www.supernano.com/support/resources/mem.cfm>.

Intel E5-2600 Series Processor LRDIMM Memory Support							
Ranks Per DIMM & Data Width (See the Note Below)	Memory Capacity Per DIMM		Speed (MT/s) and Voltage Validated by Slot per Channel (SPC) and DIMM Per Channel (DPC)				
			1 Slot Per Channel		2 Slots Per Channel		
			1DPC		1DPC and 2DPC		
			1.35V	1.5V	1.35V	1.5V	
QRx4 (DDP)	16GB	32GB	1066, 1333	1066, 1333	1066	1066, 1333	
QRx8 (P)	8GB	16GB	1066, 1333	1066, 1333	1066	1066, 1333	

Note: For detailed information on memory support and updates, please refer to the SMC Recommended Memory List posted on our website at <http://www.supernano.com/support/resources/mem.cfm>.

Note: For the memory modules to work properly, please install DIMM modules of the same type, same speed and same operating frequency. Mixing RDIMMs, UDIMMs or LRDIMMs is not allowed. Do not install both ECC and Non-ECC memory modules on the same motherboard.

1 CPU, 2 DIMMs

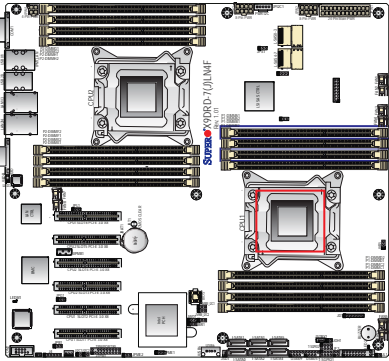

1 CPU, 4 DIMMs

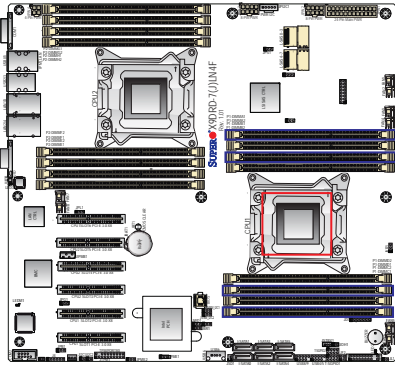

1 CPU, 5-8 DIMMs

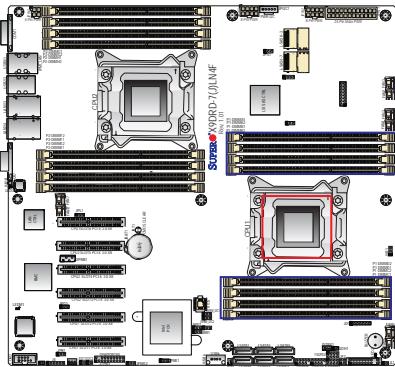

←
Populate blue DIMM slots first,
then the rest in any order

2 CPU, 4 DIMMs

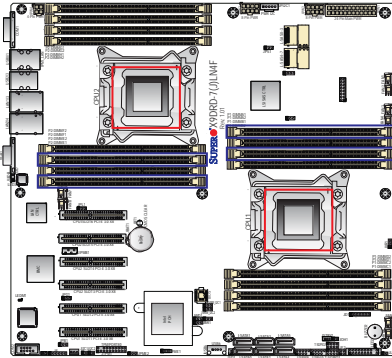

2 CPU, 6 DIMMs

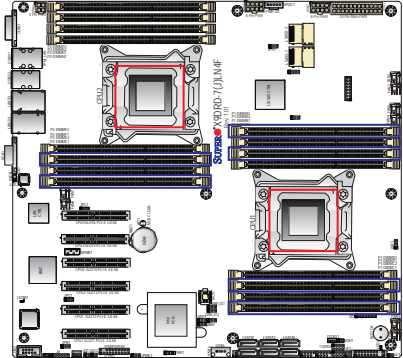

2 CPU, 8 DIMMs

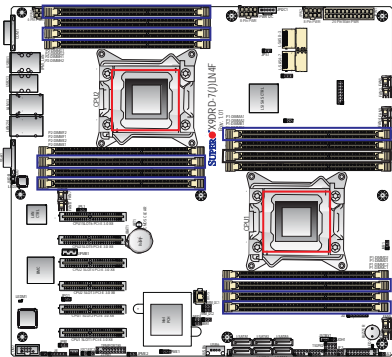

2 CPU, 10-16 DIMMs

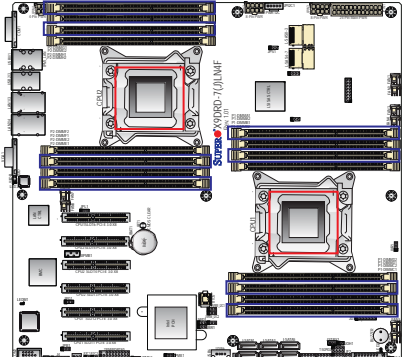

Populate blue DIMM slots first, then any memory pairs in the remaining slots.

For two CPUs and 16 DIMMs, populate all DIMM slots.

5-6 Adding PCI Add-On Cards

The 6047R-E1R24L can accommodate up to six full height PCI-E 3.0 x8 expansion (add-on) cards.

Installing an Add-on Card

1. Begin by removing the shield for the PCI slot you wish to populate.
2. Fully seat the card into the slot, pushing down with your thumbs evenly on both sides of the card.
3. Finish by using a screw to secure the top of the card shield to the chassis. The PCI slot shields protect the serverboard and its components from EMI and aid in proper ventilation, so make sure there is always a shield covering each unused slot.

5-7 Serverboard Details

Figure 5-4. X9DRD-7LN4F-JBOD Layout

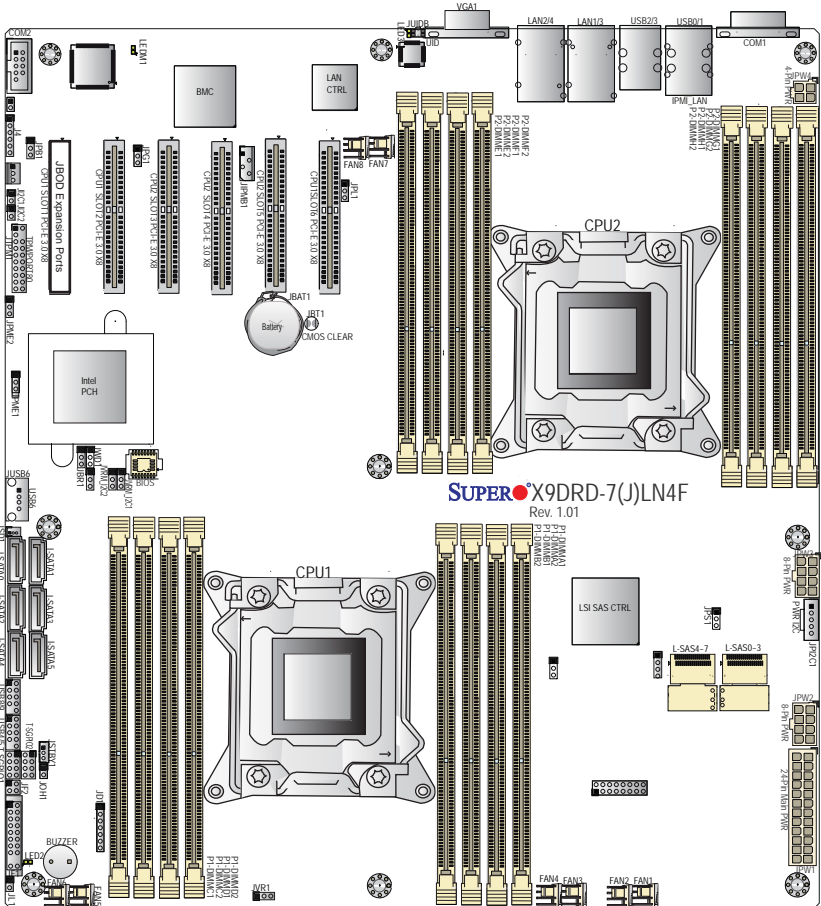

Notes

Jumpers not indicated are for test purposes only.

The SSG-6047R-E1R24L comes pre-installed with a JBOD expansion port installed in PCI-E slot 1.

Please note that the PCI slots are enabled when their corresponding processors are installed. "CPU2 Slot 4" indicates that the second CPU must be installed in the CPU2 socket to enable this PCI slot.

X9DRD-7LN4F-JBOD Quick Reference

Jumper	Description	Default Setting
JBT1	Clear CMOS	See Section 5-9
JI ² C1/JI ² C2	SMB to PCI-E Slots	Pins 2-3 (Normal)
JPB1	BMC Enable/Disable	Pins 1-2 (Enabled)
JPG1	VGA Enable/Disable	Pins 1-2 (Enabled)
JPL1	GLAN1/GLAN2 Enable/Disable	Pins 1-2 (Enabled)
JPS1	SAS Enabled	Pins 1-2 (Enabled)
JWD1	Watch Dog	Pins 1-2 (Reset)

Connector	Description
COM1/COM2	Backplane COM Port1/Front Accessible COM2 Header
FAN1~8	CPU/System Fan Headers
IPMI LAN	Dedicated IPMI LAN port
I-SATA 1~6	Intel SATA Ports 0~5
JD1	Speaker/Power LED Indicator
JF1	Front Panel Control Header
JF2	LAN3 (NIC3) / LAN4 (NIC4) LED Headers
JIPMB1	4-pin External BMC I ² C Header (for an IPMI Card)
JPI ² C1	System Management SMBbus I ² C Header
JL1	Chassis Intrusion
JOH1	Overheat/Fan Fail LED
JPW1	ATX 24-Pin Power Connector
JPW2/JPW3	12V 8-Pin Power Connectors
JPW4	12V 4-Pin Power Connector
JSD1	SATA DOM (Device On Module) Power Connector
JSTBY1	Standby Header
JTPM1	TPM (Trusted Platform Module)/Port 80
JUID	UID (Unit Identification) Switch
LAN1/3, LAN2/4	G-bit Ethernet Ports
SAS0~3, 4~7	SAS 2.0 Ports 0~3, 4~7 (LSI SAS 2308 controller)
(T-)SGPIO 1/2	SATA General Purpose I/O Headers
USB 0/1, 2/3	Back Panel USB 0/1, 2/3 Ports
USB 4/5, USB 8/9	Front Panel Accessible USB Ports (4/5, 8/9)
USB6	Type A USB Embedded Drive Connector

LED	Description	State
LED2	Standby PWR LED	Solid Green (Standby Power On)
LED3	UID LED	Blue: On (Unit Identified)
LEDM1	BMC Heartbeat LED	Blinking Green (BMC Normal)

5-8 Connector Definitions

Power Connectors

A 24-pin main power supply connector (JPW1) and two 8-pin CPU power connectors (JPW2/3) must be connected to the power supply. These power connectors meet the SSI EPS 12V specification. See the table on the right for pin definitions.

Warning: To provide adequate power supply to the serverboard, be sure to connect JPW1 and both JPW2 and JPW3 to the power supply. Failure to do so will void the manufacturer warranty on your power supply and serverboard.

ATX Power 24-pin Connector Pin Definitions			
Pin#	Definition	Pin #	Definition
13	+3.3V	1	+3.3V
14	-12V	2	+3.3V
15	COM	3	COM
16	PS_ON	4	+5V
17	COM	5	COM
18	COM	6	+5V
19	COM	7	COM
20	Res (NC)	8	PWR_OK
21	+5V	9	5VSB
22	+5V	10	+12V
23	+5V	11	+12V
24	COM	12	+3.3V

Secondary Power Connector

JPW2 and JPW3 must also be connected to the power supply. See the table on the right for pin definitions.

+12V 8-pin Power Pin Definitions	
Pins	Definition
1 - 4	Ground
5 - 8	+12V

Required Connection

Power Button

The Power On connection is on pins 1 and 2 of JF1. These should be connected to the chassis power button. See the table on the right for pin definitions.

Power Button Pin Definitions (JF1)	
Pin#	Definition
1	Power Signal
2	Ground

Reset Button

The Reset Button connection is located on pins 3 and 4 of JF1 and attaches to the reset switch on the computer chassis. See the table on the right for pin definitions.

Reset Button Pin Definitions (JF1)	
Pin#	Definition
3	Reset
4	Ground

Power Fail LED

The Power Fail LED connection is located on pins 5 and 6 of JF1. Refer to the table on the right for pin definitions.

PWR Fail LED Pin Definitions (JF1)	
Pin#	Definition
5	Vcc
6	Ground

Overheat/Fan Fail/PWR Fail LED

Connect an LED to the OH connection on pins 7 and 8 of JF1 for the Overheat/Fan Fail/Power Fail and UID LED connections. The red LED on pin 7 provides warning of overheat, fan failure or power failure. The blue LED on pin 8 works as the front panel UID LED indicator. The red LED takes precedence over the blue LED by default. Refer to the table on the right for pin definitions.

OH/Fan Fail LED Pin Definitions (JF1)		OH/Fan Fail Indicator Status	
Pin#	Definition	State	Definition
7	Vcc	Off	Normal
8	Ground	On	Overheat
		Flash- ing	Fan Fail

NIC2 (JLAN2) LED

The LED connections for JLAN2 are on pins 9 and 10 of JF1. Attach an LED cable to display network activity. See the table on the right for pin definitions.

NIC2 LED Pin Definitions (JF1)	
Pin#	Definition
9	Vcc
10	Ground

NIC1 (JLAN1) LED

The LED connections for JLAN1 are on pins 11 and 12 of JF1. Attach an LED cable to display network activity. See the table on the right for pin definitions.

NIC1 LED Pin Definitions (JF1)	
Pin#	Definition
11	Vcc
12	Ground

HDD LED

The HDD LED connection is located on pins 13 and 14 of JF1. This LED is used to display all IDE/SAS/SATA activity. See the table on the right for pin definitions.

HDD LED Pin Definitions (JF1)	
Pin#	Definition
13	Vcc
14	HD Active

Power On LED

The Power On LED connector is located on pins 15 and 16 of JF1 (use JLED for a 3-pin connector). This connection is used to provide LED indication of power being supplied to the system. See the table on the right for pin definitions.

Power LED Pin Definitions (JF1)	
Pin#	Definition
15	5V Stby
16	Control

NMI Button

The non-maskable interrupt button header is located on pins 19 and 20 of JF1. Refer to the table on the right for pin definitions.

NMI Button Pin Definitions (JF1)	
Pin#	Definition
19	Control
20	Ground

Fan Headers

There are eight fan headers on the serverboard, all of which are 4-pin fans. Pins 1-3 of the fan headers are backward compatible with the traditional 3-pin fans. (Fan speed control is supported with 4-pin fans only.) See the table on the right for pin definitions. The onboard fan speeds are controlled by IPMI.

Fan Header Pin Definitions (FAN1-8)	
Pin#	Definition
1	Ground (Black)
2	+12V (Red)
3	Tachometer
4	PWR Modulation

ATX PS/2 Keyboard and PS/2 Mouse Ports

The ATX PS/2 keyboard and the PS/2 mouse are located beside the USB0/1 ports. The mouse port is above the keyboard port. See the table on the right for pin definitions.

PS/2 Keyboard and Mouse Port Pin Definitions	
Pin#	Definition
1	Data
2	NC
3	Ground
4	VCC
5	Clock
6	NC

Chassis Intrusion

The Chassis Intrusion header is designated JL1. Attach an appropriate cable from the chassis to inform you of a chassis intrusion when the chassis is opened

Chassis Intrusion Pin Definitions	
Pin#	Definition
1	Intrusion Input
2	Ground

Ethernet Ports

Four Ethernet ports are located on the I/O backplane. A dedicated IPMI LAN port is also included to provide KVM support for IPMI 2.0. These ports accept RJ45 type cables. Please refer to Section 5-11 for LAN LED information.



Internal Speaker

The internal speaker, located at SP1, can be used to provide audible indications for various beep codes. See the table on the right for pin definitions..

Internal Buzzer (SP1) Pin Definition		
Pin#	Definitions	
Pin 1	Pos. (+)	Beep In
Pin 2	Neg. (-)	Alarm Speaker

Power LED/Speaker

On the JD1 header, pins 1-3 are for a power LED and pins 4-7 are for the speaker. Close pins 4-7 with a jumper to use an external speaker. If you wish to use the onboard speaker, please close pins 6-7. See the table on the right for speaker pin definitions.

PWR LED Connector Pin Definitions	
Pin Setting	Definition
Pin 1	Anode (+)
Pin2	Cathode (-)
Pin3	NA

Speaker Connector Pin Settings	
Pin Setting	Definition
Pins 4-7	External Speaker
Pins 6-7	Internal Speaker

Overheat/Fan Fail LED

The JOH1 header is used to connect an LED indicator to provide warnings of chassis overheating and fan failure. This LED will blink when a fan failure occurs. Refer to the table on the right for pin definitions.

OH/Fan Fail LED Status	
State	Message
Solid	Overheat
Blinking	Fan Fail

Serial Ports

Two serial ports are included on the serverboard. COM1 is a backpanel port and COM2 is a header located near the PCI-E slot 1. See the table on the right for pin definitions.

Serial Port Pin Definitions (COM1/COM2)			
Pin #	Definition	Pin #	Definition
1	DCD	6	DSR
2	RXD	7	RTS
3	TXD	8	CTS
4	DTR	9	RI
5	Ground	10	NC

Universal Serial Bus (USB)

There are four Universal Serial Bus ports (USB0/1/2/3) located on the I/O panel. In addition, there is one Type A port (USB6) and four headers (USB4/5/8/9) located on the serverboard. The headers can be used to provide front side USB access (cables not included). See the table on the right for pin definitions.

Back Panel USB (USB 0/1/2/3)	
Pin#	Definitions
1	+5V
2	PO-
3	PO+
4	Ground
5	N/A

USB Header (USB4/5/8/9/6) Pin Definitions			
USB4/6		USB5/7	
Pin #	Definition	Pin #	Definition
1	+5V	1	+5V
2	PO-	2	PO-
3	PO+	3	PO+
4	Ground	4	Ground
5	N/A	5	Key

SGPIO Headers

The SGPIO (Serial General Purpose Input/Output) headers are used to communicate with the enclosure management chip on the backplane. See the table on the right for pin definitions.

SGPIO Header Pin Definitions			
Pin#	Definition	Pin	Definition
1	NC	2	NC
3	Ground	4	DATA Out
5	Load	6	Ground
7	Clock	8	NC

NC = No Connection

DOM Power Connector

A power connector for SATA DOM (Disk On Module) devices is located at JSD1. Connect an appropriate cable here to provide power support for your Serial Link DOM devices.

DOM PWR Pin Definitions	
Pin#	Definition
1	+5V
2	Ground
3	Ground

Overheat LED/Fan Fail (JOH1)

The JOH1 header is used to connect an LED to provide warning of chassis overheating or fan failure. This LED will blink to indicate a fan failure. Refer to the tables on right for LED status and pin definitions.

OH/Fan Fail LED States		Overheat LED Pin Definitions	
State	Message	Pin#	Definition
Solid	Overheat	1	5vDC
Blinking	Fan Fail	2	OH Active

IPMB

A System Management Bus header for IPMI 2.0 is located at IPMB. Connect the appropriate cable here to use the IPMB I²C connection on your system.

IPMB Header Pin Definitions	
Pin#	Definition
1	Data
2	Ground
3	Clock
4	No Connection

Standby Power Header

The +5V Standby Power header is located at JSTBY1 on the motherboard. See the table on the right for pin definitions. (You must also have a card with a Standby Power connector and a cable to use this feature.)

Standby PWR Pin Definitions	
Pin#	Definition
1	+5V Standby
2	Ground
3	Wake-up

LAN3/LAN4 LED Indicators

The NIC (Network Interface Controller) LED connections for LAN Port 3 are located on pins 3 and 4 of JF2, and the LED connections for LAN Port 4 is on Pins 1 and 2 of JF2. Attach NIC LED cables here to display network activities. Refer to the table on the right for pin definitions.

LAN Ports 3/4 LED Indicators (JF2) Pin Definitions			
Pin#	Definition	Pin	Definition
1	LAN4 Activity	2	LAN4 Link
3	LAN3 Activity	4	LAN3 Link

Power Supply SMBus I²C Header

The power System Management Bus header at JPI²C1 is used to monitor the status of the power supply, fan and system temperature. See the table on the right for pin definitions.

PWR SMBus Header Pin Definitions	
Pin#	Definition
1	Clock
2	Data
3	PWR Fail
4	Ground
5	+3.3V

Unit Identifier Switch

The UID Switch is located next to the LAN 2/4 ports on the backplane. The Rear UID LED (LE2) is located next to the UID switch. The control panel UID LED connection is on pins 7/8 of JF1. Connect a cable to pin 8 on JF1 for Front Panel UID LED indication. When you press the UID switch, both the rear UID LED and control panel UID LED indicators will be turned on. Press the UID switch again to turn off both LED Indicators. These indicators provide easy identification of a system unit that may be in need of service.

UID Switch	
Pin#	Definition
1	Ground
2	Ground
3	Button In
4	Ground

UID LED (LE2) Status		
Color/State	OS	Status
Blue: On	Windows OS	Unit Identified
Blue: Blinking	Linux OS	Unit Identified

Note: UID can also be triggered via IPMI. For more information on IPMI, please refer to the IPMI User's Guide posted on our Website @<http://www.supermicro.com>.

TPM Header/Port 80

A Trusted Platform Module/Port 80 header is located at JTPM1 to provide TPM support and a Port 80 connection. Use this header to enhance system performance and data security. See the table on the right for pin definitions.

TPM/Port 80 Header Pin Definitions			
Pin #	Definition	Pin #	Definition
1	LCLK	2	GND
3	LFRAME#	4	<(KEY)>
5	LRESET#	6	+5V (X)
7	LAD 3	8	LAD 2
9	+3.3V	10	LAD1
11	LAD0	12	GND
13	SMB_CLK4	14	SMB_DAT4
15	+3V_DUAL	16	SERIRQ
17	GND	18	CLKRUN# (X)
19	LPCPD#	20	LDRQ# (X)

5-9 Jumper Settings

Explanation of Jumpers

To modify the operation of the serverboard, jumpers can be used to choose between optional settings. Jumpers create shorts between two pins to change the function of the connector. Pin 1 is identified with a square solder pad on the printed circuit board. See the serverboard layout pages for jumper locations.

Note: On a two-pin jumper, "Closed" means the jumper is on both pins and "Open" means the jumper is either on only one pin or completely removed.

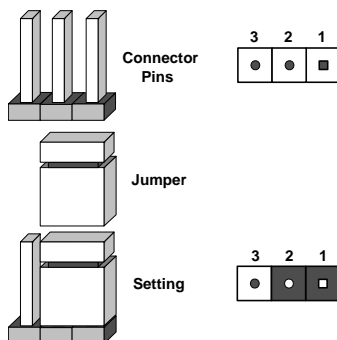

CMOS Clear

JBT1 is used to clear CMOS (which will also clear any passwords). Instead of pins, this jumper consists of contact pads to prevent accidentally clearing the contents of CMOS.

To clear CMOS,

1. First power down the system and unplug the power cord(s).
2. With the power disconnected, short the CMOS pads with a metal object such as a small screwdriver.
3. Remove the screwdriver (or shorting device).
4. Reconnect the power cord(s) and power on the system.

Note: Do not use the PW ON connector to clear CMOS.

BMC Enable

Jumper JPB1 allows you to enable the embedded the Winbond WPCM450R BMC (Baseboard Management) Controller to provide IPMI 2.0/KVM support on the serverboard. See the table on the right for jumper settings.

BMC Enable Jumper Settings	
Jumper Setting	Definition
Pins 1-2	BMC Enable
Pins 2-3	Normal (Default)

GLAN Enable/Disable

JPL1 enables or disables the GLAN ports on the serverboard. See the table on the right for jumper settings.

GLAN Enable Jumper Settings	
Jumper Setting	Definition
1-2	Enabled (default)
2-3	Disabled

I²C Bus to PCI-Exp. Slots

Jumpers JI²C1 and JI²C2 allow you to connect the System Management Bus (I²C) to the PCI-Express slots. Both jumpers must be set to the same setting. See the table on the right for jumper settings.

I ² C to PCI-E Slots Jumper Settings	
Jumper Setting	Definition
Pins 1-2	Enabled
Pins 2-3	Disabled

VGA Enable/Disable

JPG1 allows you to enable or disable the VGA port. The default position is on pins 1 and 2 to enable VGA. See the table on the right for jumper settings.

VGA Enable/Disable Jumper Settings	
Jumper Setting	Definition
Pins 1-2	Enabled
Pins 2-3	Disabled

SAS Enable

Jumper JPS1 allows the user to enable onboard LSI SAS support. The default setting is on 1-2 to enable SAS connections 0~3, 4~7. See the table on the right for jumper settings.

SAS Enable Jumper Settings	
Jumper Setting	Definition
1-2	Enabled (Default)
2-3	Disabled

Watch Dog Enable/Disable

Watch Dog is a system monitor that can reboot the system when a software application hangs. Jumping pins 1-2 will cause WD to reset the system if an application hangs. Jumping pins 2-3 will generate a non-maskable interrupt signal for the application that hangs. See the table on the right for jumper settings. Watch Dog must also be enabled in BIOS.

Watch Dog Jumper Settings	
Jumper Setting	Definition
Pins 1-2	Reset
Pins 2-3	NMI
Open	Disabled

5-10 Onboard Indicators

LAN LEDs

The Ethernet ports (located beside the VGA port) have two LEDs. On each port, the yellow LED flashes to indicate activity while the other LED may be green, amber or off to indicate the speed of the connection. See the table on the right for the functions associated with the connection speed LED.

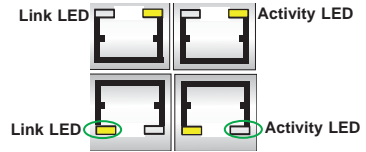

JLAN1/2 LED (Connection Speed Indicator)	
LED Color	Definition
Off	NC or 10 Mbps
Green	100 Mbps
Amber	1 Gbps

IPMI Dedicated LAN LEDs

An additional IPMI Dedicated LAN is also located on the I/O backplane. The amber LED on the right indicates activity, while the green LED on the left indicates the speed of the connection. See the table at right for more information.



IPMI LAN Link LED & Activity LED		
LED	Status	Definition
Link (Left)	Green: Solid	100 Mbps
Activity (Right)	Amber: Blinking	Active

Standby Power LED

An Standby Power LED is located at LE1. This LED Indicator is lit when the system is on. Be sure to unplug the power cable before removing or adding any components. See the table on the right for more details.

Onboard PWR LED Indicator LED States	
LED Color	Definition
Off	System Off (PWR cable not connected)
Green	System On
Green: Flashing Quickly	ACPI S1 State

BMC Heartbeat LED

A BMC Heartbeat LED is located at LEDM1 on the serverboard. When blinking, BMC is functioning normally.

BMC Heartbeat LED	
LED	Definition
D1	Blinking: BMC: Normal

5-11 SATA Ports

Serial ATA Ports

There are six Serial ATA Ports (I-SATA0~I-SATA 5) located on the serverboard, including four SATA2 ports and two SATA3 ports. These ports provide serial-link signal connections, which are faster than Parallel ATA. See the table on the right for pin definitions.

SATA Port Pin Definitions			
Pin#	Definition	Pin	Definition
1	Ground	2	TXP
3	TXN	4	Ground
5	RXN	6	RXP
7	Ground		

Note: For more information on SATA HostRAID configuration, please refer to the Intel SATA HostRAID User's Guide posted on our website @ <http://www.supermicro.com>.

SAS2 Ports

Eight Serial Attached SCSI Ports (SAS0~3, 4~7) located on the motherboard to provide serial link connections. These ports are supported by the LSI SAS2 2308 Controller. See the table on the right for pin definitions.

SAS Port Pin Definitions			
Pin#	Definition	Pin	Definition
1	Ground	2	TXP
3	TXN	4	Ground
5	RXN	6	RXP
7	Ground		

5-12 Installing Software

After the hardware has been installed, you should first install the operating system and then the drivers. The necessary drivers are all included on the Supermicro CDs that came packaged with your serverboard.

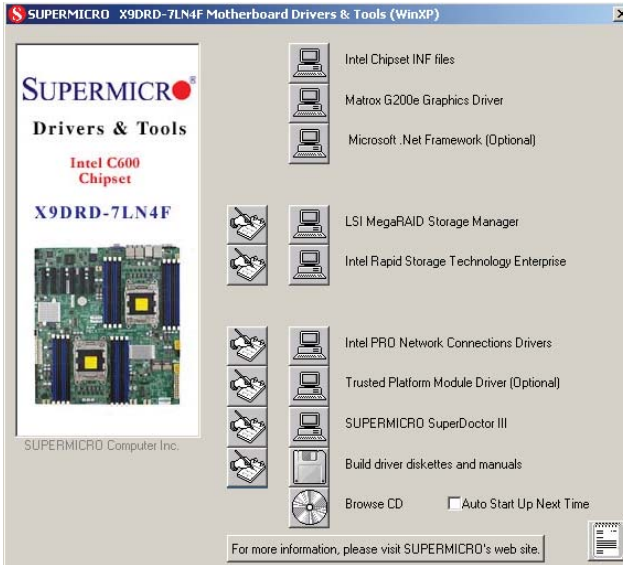

Driver/Tool Installation Display Screen

Note: Click the icons showing a hand writing on paper to view the readme files for each item. Click the computer icons to the right of these items to install each item (from top to the bottom) one at a time. **After installing each item, you must re-boot the system before moving on to the next item on the list.** The bottom icon with a CD on it allows you to view the entire contents of the CD.

SuperDoctor III

The SuperDoctor® III program is a Web base management tool that supports remote management capability. It includes Remote and Local Management tools. The local management is called SD III Client. The SuperDoctor III program included on the CD-ROM that came with your serverboard allows you to monitor the environment and operations of your system. SuperDoctor III displays crucial system information such as CPU temperature, system voltages and fan status. See the Figure below for a display of the SuperDoctor III interface.

Note: The default User Name and Password for SuperDoctor III is ADMIN / ADMIN.

Note: When SuperDoctor is first installed, it adopts the temperature threshold settings that have been set in BIOS. Any subsequent changes to these thresholds must be made within SuperDoctor, as the SuperDoctor settings override the BIOS settings. To set the BIOS temperature threshold settings again, you would first need to uninstall SuperDoctor.

Supero Doctor III Interface Display Screen (Health Information)

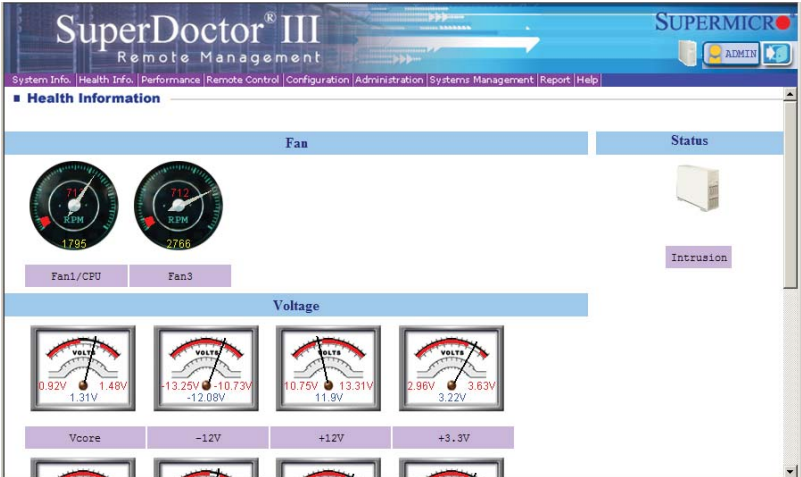

Supero Doctor III Interface Display Screen (Remote Control)



Graceful power control (cancelable)

Supero Doctor III allows a user to inform the OS to reboot or shut down the system within 30 seconds. On the system console, a pop-up window will appear with a message telling the local user to save his working files. Before the system reboots or shuts down, it's allowed to cancel the action either locally or remotely.

Power control (noncancelable)

Supero Doctor III allows a user to inform the OS to reboot or shut down the system right away. The system will reboot or shut down without any warning messages. It's not allowed to cancel the action.

Note: The SuperDoctor III program and User's Manual can be downloaded from the Supermicro web site at <http://www.supermicro.com/products/accessories/software/SuperDoctorIII.cfm>.

For Linux, we recommend using SuperDoctor II.

Notes

Chapter 6

Advanced Chassis Setup

This chapter covers the steps required to install components and perform maintenance on the SC836E16-R920B chassis. For component installation, follow the steps in the order given to eliminate the most common problems encountered. If some steps are unnecessary, skip ahead to the step that follows.

Tools Required: The only tool you will need to install components and perform maintenance is a Philips screwdriver.

6-1 Static-Sensitive Devices

Electrostatic discharge (ESD) can damage electronic components. To prevent damage to any printed circuit boards (PCBs), it is important to handle them very carefully. The following measures are generally sufficient to protect your equipment from ESD damage.

Precautions

- Use a grounded wrist strap designed to prevent static discharge.
- Touch a grounded metal object before removing any board from its antistatic bag.
- Handle a board by its edges only; do not touch its components, peripheral chips, memory modules or gold contacts.
- When handling chips or modules, avoid touching their pins.
- Put the serverboard, add-on cards and peripherals back into their antistatic bags when not in use.
- For grounding purposes, make sure your computer chassis provides excellent conductivity between the power supply, the case, the mounting fasteners and the serverboard.

Unpacking

The serverboard is shipped in antistatic packaging to avoid static damage. When unpacking the board, make sure the person handling it is static protected.

Figure 6-1. Front and Rear Chassis Views

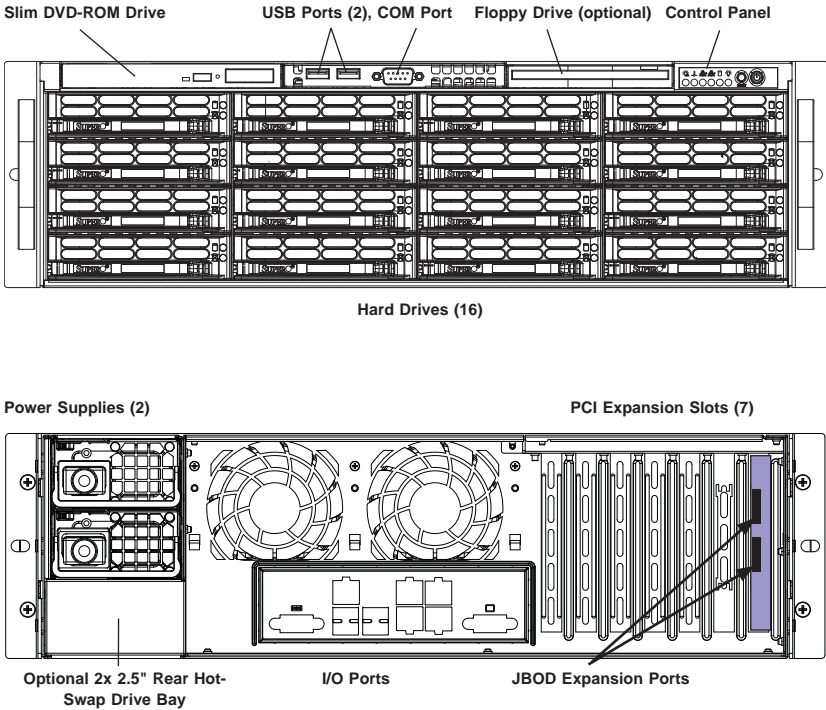

6-2 Control Panel

The control panel (located on the front of the chassis) must be connected to the JF1 connector on the serverboard to provide you with system status indications. A ribbon cable has bundled these wires together to simplify the connection. Connect the cable from JF1 on the serverboard to the Control Panel PCB (printed circuit board). Make sure the red wire plugs into pin 1 on both connectors. Pull all excess cabling out of the airflow path. The LEDs inform you of system status. See Chapter 3 for details on the LEDs and the control panel buttons. Details on JF1 can be found in Chapter 5.

6-3 System Fans

Three 8-cm hot-swap chassis fans and two 8-cm exhaust fans provide the cooling for the SuperServer 6037R-E1R16L. It is very important that the chassis top cover is properly installed and making a good seal in order for the cooling air to circulate properly through the chassis and cool the components. See Figure 6-2.

System Fan Failure

Fan speed is controlled by system temperature via a BIOS setting. If a fan fails, the remaining fans will ramp up to full speed and the overheat/fan fail LED on the control panel will turn on. Replace any failed fan at your earliest convenience with the same type and model (the system can continue to run with a failed fan). Remove the top chassis cover while the system is still running to determine which of the fans has failed.

Replacing System Fans

Removing a Fan

1. Remove the chassis cover.
2. Depress the tab on the side of the fan to unlock and remove the fan along with its housing. The fan's power connections will automatically detach.
3. System power does not need to be shut down since the fans are hot-pluggable.

Installing a New Fan

1. Replace the failed fan with an identical 8-cm, 12 volt fan (available from Supermicro, p/n FAN-0070L).
2. Position the new fan into the space vacated by the failed fan previously removed. A "click" can be heard when the fan is fully installed in place and the power connections are made.
3. If the system power is on, the hot-plug feature will cause the fan to start immediately upon being connected to its header on the serverboard.

Rear Exhaust Fans

The two rear exhaust fans are also hot-swappable. To remove, depress the tab on the side of the fan to unlock it, then pull it straight up and out of the chassis.

Figure 6-2. Removing System Cooling Fans

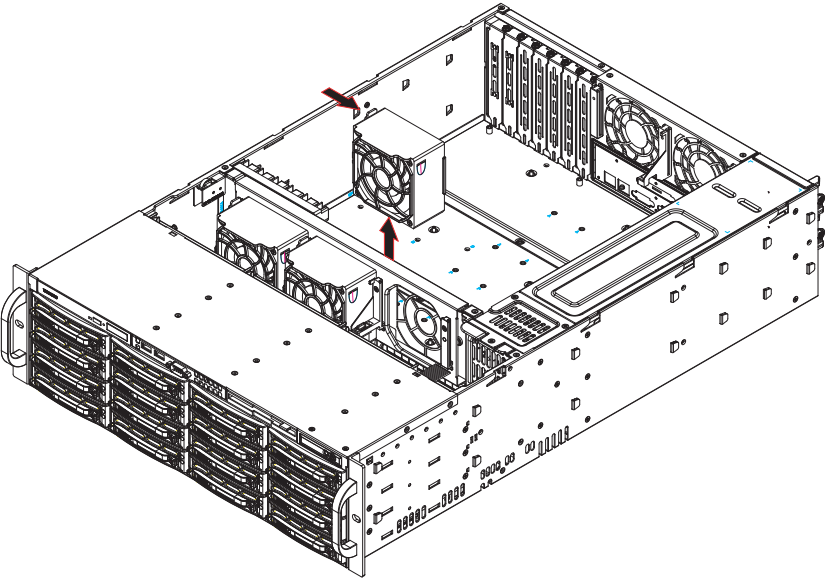

6-4 Drive Bay Installation/Removal

Accessing the Drive Bays

SATA Drives: You do not need to access the inside of the chassis or remove power to replace or swap SATA drives. Proceed to the next step for instructions.

Note: You must use standard 1" high, drives in the SuperServer 6037R-E1R16L.

DVD-ROM/Floppy Disk Drive: For installing/removing the DVD-ROM or floppy disk drive, you will need to gain access to the inside of the server by removing the top cover of the chassis. Proceed to the "DVD-ROM and Floppy Drive Installation" section later in this chapter for instructions.

5.25" Drive Bay: For installing/removing a component in the 5.25" drive bay, proceed to the "5.25" Drive Bay Installation" section later in this chapter for instructions.



Use caution when working around the backplane. Do not touch the backplane with any metal objects and make sure no ribbon cables touch the backplane or obstruct the holes, which aid in proper airflow.

SATA Drive Installation

Mounting a SATA Drive in a Drive Carrier

The SATA drives are mounted in drive carriers to simplify their installation and removal from the chassis. These carriers also help promote proper airflow for the drives. For this reason, even empty carriers without SATA drives installed must remain in the chassis. To add a new SATA drive, install a drive into the carrier with the printed circuit board side facing down so that the mounting holes align with those in the carrier. Secure the drive to the carrier with four screws, as shown in Figure 6-3.

Installing/Removing SATA Drives

1. To remove a SATA drive, first push the release button located beside the drive's LEDs.
2. Swing the handle fully out and use it to pull the drive carrier straight out (see Figure 6-4).

Figure 6-3. Mounting a SATA Drive in a Carrier

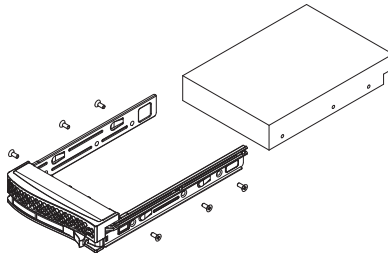

Warning! Enterprise level hard disk drives are recommended for use in Supermicro chassis and servers. For information on recommended HDDs, visit the Supermicro Web site at <http://www.supermicro.com/products/info/files/storage/SAS-1-CompList-110909.pdf>



Important: Regardless of how many hard drives are installed, all drive carriers must remain in the drive bays to maintain proper airflow.

Figure 6-4. Removing a Drive Carrier

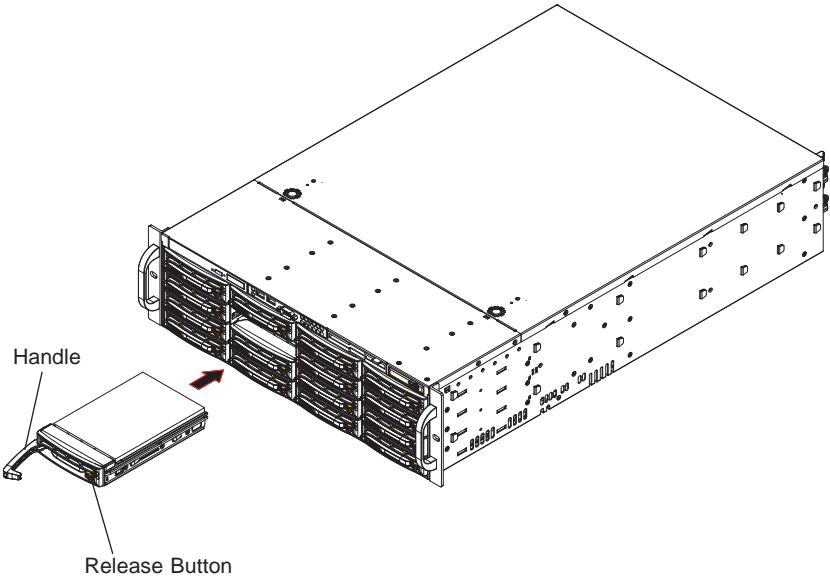

Important: All drive carriers must remain in the drive bays to maintain proper cooling airflow.

Hard Drive Backplane

The hard drives plug into a backplane that provides power, drive ID and bus termination. A RAID controller can be used with the backplane to provide data security. The operating system you use must have RAID support to enable the hot-swap capability of the SATA drives. The backplane is already preconfigured, so there are no jumpers or switches present on it.

Removing the Air Shroud

Under most circumstances you will not need to remove the air shroud to perform any service on the system. However, if you wish to temporarily remove it (the air shroud should always be in place when the system is operating), please follow this procedure.

The air shroud is secured into place with the rear exhaust fans. Remove both of these fans by depressing their tabs and lifting them out of the chassis. You can then lift the air shroud out (see Figure 6-5). To reinstall, simply position the air shroud in its proper place and push both fans back in until you hear them click into place.

Figure 6-5. Removing the Air Shroud

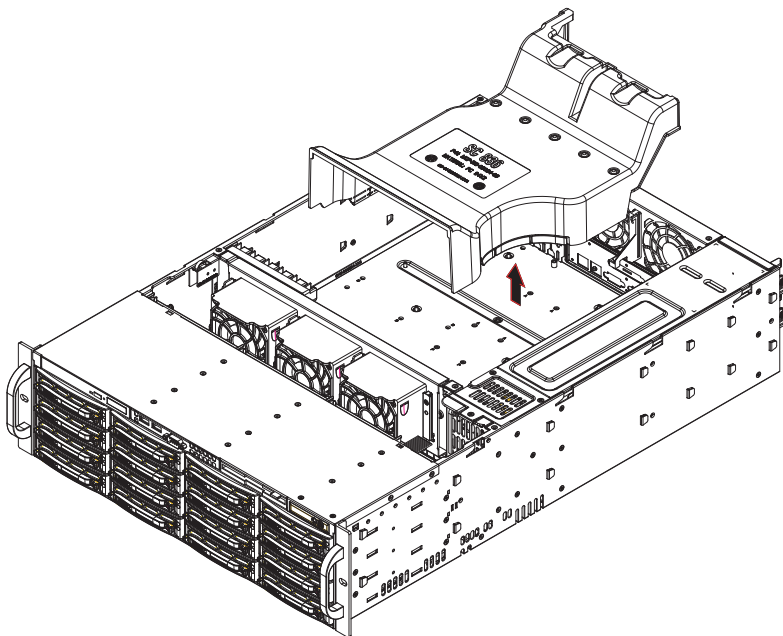

DVD-ROM Installation

The top cover of the chassis must be opened to gain full access to the DVD-ROM. The 6037R-E1R16L accommodates only slim type DVD-ROM drives. Side mounting brackets are typically needed to mount a slim DVD-ROM drive in the 6037R-E1R16L server.

First, release the retention screws that secure the server unit to the rack. Grasp the two handles on either side and pull the unit straight out until it locks (you will hear a "click"). Next, depress the two buttons on the top of the chassis to release the top cover and at the same time, push the cover away from you until it stops. You can then lift the top cover from the chassis to gain full access to the inside of the server. You must power down the system before installing or removing a DVD-ROM drive.

Drives mount on rails and should "click" into place to be correctly and fully installed in their bays.

A color mark on a cable typically designates the location of pin 1.

6-5 Power Supply

The SuperServer 6037R-E1R16L has an 920 watt redundant power supply consisting of two power modules. Each power supply module has an auto-switching capability, which enables it to automatically sense and operate at a 100V - 240V input voltage.

Power Supply Failure

If either of the two power supply modules fail, the other will take the full load and allow the system to continue operation without interruption. The Power Fail LED will illuminate and remain on until the failed module has been replaced. Replacements can be ordered directly from Supermicro (see contact information in the Preface). The power supply modules have a hot-swap capability, meaning you can replace the failed module without powering down the system.

Removing/Replacing the Power Supply

You do not need to shut down the system to replace a power supply module. The backup power supply module will keep the system up and running while you replace the failed hot-swap module. Replace with the same model (see part number in Appendix B), which can be ordered directly from Supermicro.

1. First unplug the power cord from the failed power supply module.
2. Depress the locking tab on the power supply module and use the handle to pull it straight out of the chassis.
3. Replace the failed module with another by simply pushing the new power supply module into the power bay until you hear a click.
4. Secure the locking tab on the unit and finish by plugging the AC power cord back into the module. See Figure 6-6.

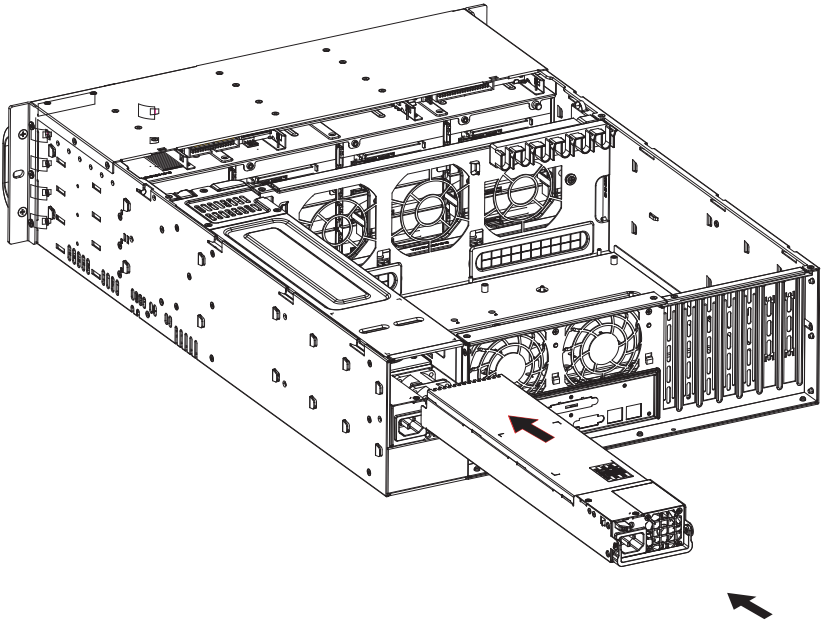
Figure 6-6. Replacing a Power Supply Module

6-6 Attaching a JBOD Expansion Chassis

The SSG-6037R-E1R16L features dual JBOD expansion ports. The Figure below illustrates the recommended expansion strategy. The JBOD attachment will vary depending on the specific JBOD chassis that is being connected. JBOD image provided for reference purposes, port location and routing specifications are subject to change. Please follow the instructions provided with the JBOD.

Figure 6-7. JBOD Expansion Port

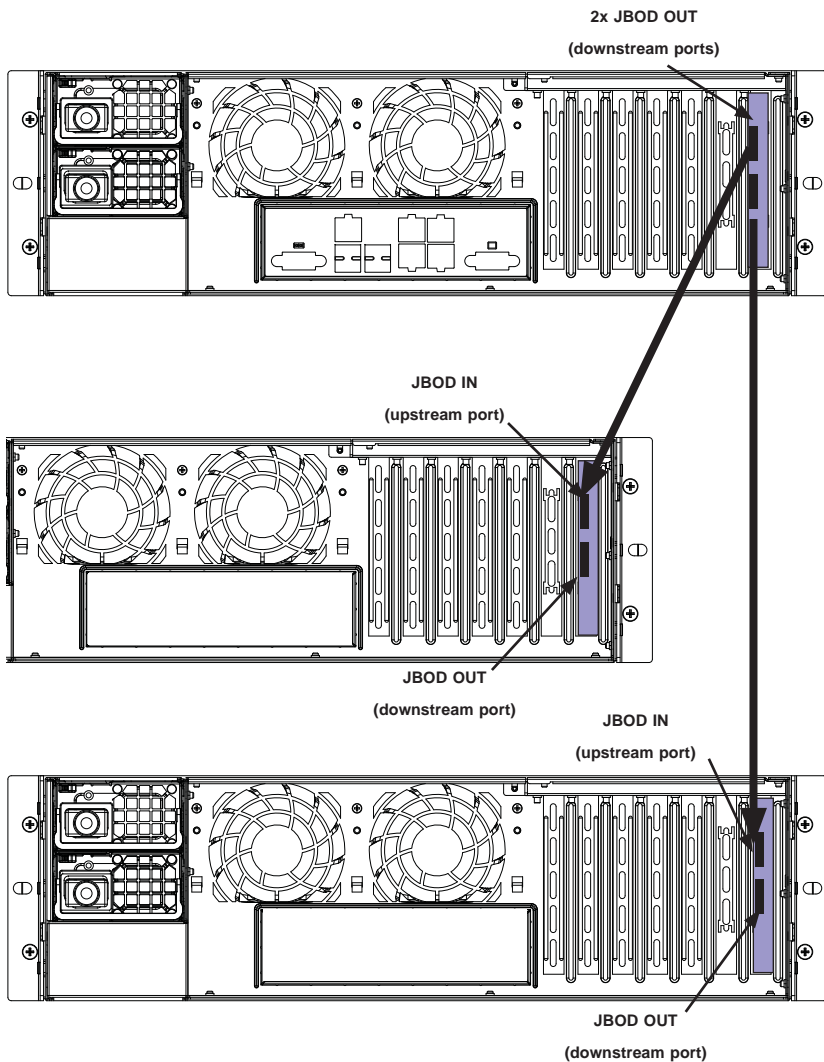

Notes

Chapter 7

BIOS

7-1 Introduction

This chapter describes the AMI BIOS Setup utility for the X9DRD-7LN4F. It also provides the instructions on how to navigate the AMI BIOS Setup utility screens. The AMI ROM BIOS is stored in a Flash EEPROM and can be easily updated.

Starting BIOS Setup Utility

To enter the AMI BIOS Setup utility screens, press the key while the system is booting up.

 **Note:** In most cases, the key is used to invoke the AMI BIOS setup screen. There are a few cases when other keys are used, such as <F3>, <F4>, etc.

Each main BIOS menu option is described in this manual. The Main BIOS setup menu screen has two main frames. The left frame displays all the options that can be configured. Grayed-out options cannot be configured. Options in blue can be configured by the user. The right frame displays the key legend. Above the key legend is an area reserved for informational text. When an option is selected in the left frame, it is highlighted in white. Often informational text will accompany it.

 **Note:** The AMI BIOS has default informational messages built in. The manufacturer retains the option to include, omit, or change any of these informational messages.

The AMI BIOS Setup utility uses a key-based navigation system called "hot keys." Most of the AMI BIOS setup utility "hot keys" can be used at any time during setup navigation. These keys include <F3>, <F4>, <Enter>, <ESC>, arrow keys, etc.

Note 1: Options printed in **Bold** are default settings.

 **Note 2:** <F3> is used to load optimal default settings. <F4> is used to save the settings and exit the setup utility.

How To Change the Configuration Data

The configuration data that determines the system parameters may be changed by entering the AMI BIOS Setup utility. This Setup utility can be accessed by pressing <Delete> at the appropriate time during system boot.

 **Note:** For AMI UEFI BIOS Recovery, please refer to the UEFI BIOS Recovery User Guide posted @<http://www.supermicro.com/support/manuals/>.

Starting the Setup Utility

Normally, the only visible Power-On Self-Test (POST) routine is the memory test. As the memory is being tested, press the <Delete> key to enter the main menu of the AMI BIOS Setup utility. From the main menu, you can access the other setup screens. An AMI BIOS identification string is displayed at the left bottom corner of the screen below the copyright message.

 **Warning!** Do not upgrade the BIOS unless your system has a BIOS-related issue. Flashing the wrong BIOS can cause irreparable damage to the system. In no event shall the manufacturer be liable for direct, indirect, special, incidental, or consequential damage arising from a BIOS update. If you have to update the BIOS, do not shut down or reset the system while the BIOS is being updated to avoid possible boot failure.

7-2 Main Setup

When you first enter the AMI BIOS Setup utility, you will enter the Main setup screen. You can always return to the Main setup screen by selecting the Main tab on the top of the screen. The Main BIOS Setup screen is shown below.



The AMI BIOS Main menu displays the following information:

System Date/System Time

Use this option to change the system time and date. Highlight *System Time* or *System Date* using the arrow keys. Enter new values through the keyboard and press <Enter>. Press the <Tab> key to move between fields. The date must be entered in Day MM/DD/YY format. The time is entered in HH:MM:SS format. (**Note:** The time is in the 24-hour format. For example, 5:30 P.M. appears as 17:30:00.).

Supermicro X9DRD-7LN4F-JBOD**Version**

This item displays the SMC version of the BIOS ROM used in this system.

Build Date

This item displays the date that the BIOS Setup utility was built.

Memory Information**Total Memory**

This displays the amount of memory that is available in the system.

7-3 Advanced Setup Configurations

Select the Advanced tab to access the following submenu items.

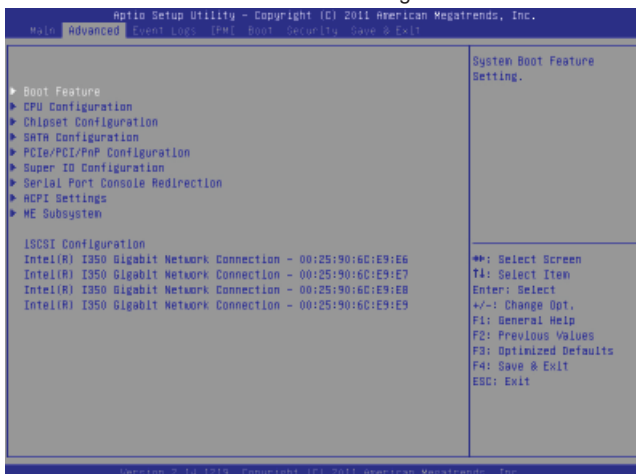

► Boot Feature

Quiet Boot

This feature allows the user to select bootup screen display between POST messages and the OEM logo. Select Disabled to display the POST messages. Select Enabled to display the OEM logo instead of the normal POST messages. The options are **Enabled** and Disabled.

AddOn ROM Display Mode

Use this item to set the display mode for the Option ROM. Select Keep Current to use the current AddOn ROM Display setting. Select Force BIOS to use the Option ROM display mode set by the system BIOS. The options are Keep Current and **Force BIOS**.

Bootup Num-Lock

Use this feature to set the Power-on state for the Numlock key. The options are Off and **On**.

Wait For 'F1' If Error

Select Enabled to force the system to wait until the 'F1' key is pressed if an error occurs. The options are Disabled and **Enabled**.

Interrupt 19 Capture

Interrupt 19 is the software interrupt that handles the boot disk function. When this item is set to Enabled, the ROM BIOS of the host adaptors will "capture" Interrupt 19

at bootup and allow the drives that are attached to these host adaptors to function as bootable disks. If this item is set to Disabled, the ROM BIOS of the host adaptors will not capture Interrupt 19, and the drives attached to these adaptors will not function as bootable devices. The options are **Enabled** and Disabled.

Power Configuration

Watch Dog Function

If enabled, the Watch Dog timer will allow the system to automatically reboot when a non-recoverable error occurs that lasts for more than five minutes. The options are Enabled and **Disabled**.

Power Button Function

If this feature is set to Instant Off, the system will power off immediately as soon as the user presses the power button. If this feature is set to 4 Seconds Override, the system will power off when the user presses the power button for 4 seconds or longer. The options are **Instant Off** and 4 Seconds Override.

Restore on AC Power Loss

Use this feature to set the power state after a power outage. Select Stay Off for the system power to remain off after a power loss. Select Power On for the system power to be turned on after a power loss. Select Last State to allow the system to resume its last state before a power loss. The options are Stay Off, Power On, and **Last State**.

► CPU Configuration

This submenu displays the information of the CPU as detected by the BIOS. It also allows the user to configure CPU settings.

► Socket 1 CPU Information/Socket 2 CPU Information

This submenu displays the following information regarding the CPUs installed in Socket 1/ Socket 2.

- Type of CPU
- CPU Signature
- Microcode Patch
- CPU Stepping
- Maximum / Minimum CPU Speed

- Processor Cores
- Intel HT (Hyper-Threading) Technology
- Intel VT-x Technology
- Intel SMX Technology
- L1 Data Cache / L1 Code Cache
- L2 Cache
- L3 Cache

CPU Speed

This item displays the speed of the CPU installed in Socket 1/Socket 2.

64-bit

This item indicates if the CPU installed in Socket 1 or Socket 2 supports 64-bit technology.

Clock Spread Spectrum

Select Enable to enable Clock Spread Spectrum support, which will allow the BIOS to monitor and attempt to reduce the level of Electromagnetic Interference caused by the components whenever needed. The options are **Disabled** and Enabled.

RTID (Record Types IDs)

This feature displays the total number of Record Type IDs for local and remote pools. The options are **Optimal** and Alternate.

Hyper-threading

Select Enabled to support Intel Hyper-threading Technology to enhance CPU performance. The options are **Enabled** and Disabled.

Active Processor Cores

Set to Enabled to use a processor's second core and above. (Please refer to Intel's website for more information.) The options are **All**, 1, 2, 4, and 6.

Limit CPUID Maximum

This feature allows the user to set the maximum CPU ID value. Enable this function to boot the legacy operating systems that cannot support processors with extended CPUID functions. The options are Enabled and **Disabled** (for the Windows OS).

Execute-Disable Bit (Available if supported by the OS & the CPU)

Select Enabled to enable the Execute Disable Bit which will allow the processor to designate areas in the system memory where an application code can execute and where it cannot, thus preventing a worm or a virus from flooding illegal codes to overwhelm the processor or damage the system during an attack. The default is **Enabled**. (Refer to Intel and Microsoft Web sites for more information.)

Intel® AES-NI

Select Enable to use the Intel Advanced Encryption Standard (AES) New Instructions (NI) to ensure data security. The options are **Enabled** and Disabled.

MLC Streamer Prefetcher (Available when supported by the CPU)

If set to Enabled, the MLC (mid-level cache) streamer prefetcher will prefetch streams of data and instructions from the main memory to the L2 cache to improve CPU performance. The options are Disabled and **Enabled**.

MLC Spatial Prefetch (Available when supported by the CPU)

If this feature is set to Disabled, The CPU prefetches the cache line for 64 bytes. If this feature is set to Enabled the CPU fetches both cache lines for 128 bytes as comprised. The options are Disabled and **Enabled**.

DCU Streamer Prefetcher (Available when supported by the CPU)

Select Enabled to support Data Cache Unit (DCU) prefetch of L1 data to speed up data accessing and processing in the DCU to enhance CPU performance. The options are Disabled and **Enabled**.

DCU IP Prefetcher

Select Enabled for DCU (Data Cache Unit) IP Prefetcher support, which will prefetch IP addresses to improve network connectivity and system performance. The options are **Enabled** and Disabled.

Intel® Virtualization Technology (Available when supported by the CPU)

Select Enabled to support Intel Virtualization Technology, which will allow one platform to run multiple operating systems and applications in independent partitions, creating multiple "virtual" systems in one physical computer. The options are **Enabled** and Disabled.



Note: If there is any change to this setting, you will need to power off and restart the system for the change to take effect. Please refer to Intel's website for detailed information.)

► CPU Power Management Configuration

This submenu allows the user to configure the following CPU Power Management settings.

Power Technology

Select Energy Efficiency to support power-saving mode. Select Custom to customize system power settings. Select Disabled to disable power-saving settings. The options are Disabled, **Energy Efficient**, and Custom. If the option is set to Custom, the following items will display:

EIST (Available when Power Technology is set to Custom)

EIST (Enhanced Intel SpeedStep Technology) allows the system to automatically adjust processor voltage and core frequency to reduce power consumption and heat dissipation. The options are Disabled (GV3 Disabled), and **Enabled (GV3 Enabled)**. (**Note:** GV3 is Intel Speedstep support used on older platforms. Please refer to Intel's website for detailed information.)

Turbo Mode (Available when Power Technology is set to Custom)

Select Enabled to use the Turbo Mode to boost system performance. The options are **Enabled** and Disabled.

C1E Support (Available when Power Technology is set to Custom)

Select Enabled to enable Enhanced C1 Power State to boost system performance. The options are **Enabled** and Disabled.

CPU C3 Report (Available when Power Technology is set to Custom)

Select Enabled to allow the BIOS to report the CPU C3 State (ACPI C2) to the operating system. During the CPU C3 State, the CPU clock generator is turned off. The options are Enabled and **Disabled**.

CPU C6 Report (Available when Power Technology is set to Custom)

Select Enabled to allow the BIOS to report the CPU C6 State (ACPI C3) to the operating system. During the CPU C6 State, the power to all cache is turned off. The options are **Enabled** and Disabled.

CPU C7 Report (Available when Power Technology is set to Custom)

Select Enabled to allow the BIOS to report the CPU C7 State (ACPI C3) to the operating system. CPU C7 State is a processor-specific low C-State. The options are **Enabled** and Disabled.

Package C-State limit (Available when Power Technology is set to Custom)

This feature allows the user to set the limit on the C-State package register. The options are C0, C2, **C6**, and No Limit.

Energy/Performance Bias

Use this feature to select an appropriate fan setting to achieve maximum system performance (with maximum cooling) or maximum energy efficiency with maximum power saving). The fan speeds are controlled by the firmware management via IPMI 2.0. The options are Performance, **Balanced Performance**, Balanced Energy, and Energy Efficient.

Factory Long Duration Power Limit

This item displays the power limit (in watts) set by the manufacturer during which long duration power is maintained.

Long Duration Power Limit

This item displays the power limit (in watts) set by the user during which long duration power is maintained. The default setting is 0.

Factory Long Duration Maintained

This item displays the period of time (in seconds) set by the manufacturer during which long duration power is maintained.

Long Duration Maintained

This item displays the period of time (in seconds) during which long duration power is maintained. The default setting is 0.

Recommended Short Duration Power

This item displays the short duration power settings (in watts) recommended by the manufacturer.

Short Duration Power Limit

During Turbo Mode, the system may exceed the processors default power setting and exceed the Short Duration Power limit. By increasing this value, the processor can provide better performance for short duration. This item displays the time period during which short duration power is maintained. The default setting is 0.

► Chipset Configuration

► North Bridge

This feature allows the user to configure the settings for the Intel North Bridge.

► Integrated IO Configuration

Intel® VT-d

Select Enabled to enable Intel Virtualization Technology support for Direct I/O VT-d by reporting the I/O device assignments to the VMM (Virtual Machine Monitor) through the DMAR ACPI Tables. This feature offers fully-protected I/O resource sharing across Intel platforms, providing greater reliability, security and availability in networking and data-sharing. The options are **Enabled** and Disabled.

Intel® I/OAT

Select Enabled to enable Intel I/OAT (I/O Acceleration Technology), which significantly reduces CPU overhead by leveraging CPU architectural improvements and freeing the system resource for other tasks. The options are Disabled and **Enabled**.

DCA Support

When set to Enabled, this feature uses Intel's DCA (Direct Cache Access) Technology to improve data transfer efficiency. The options are **Enabled** and Disabled.

IIO 1 PCIe Port Bifurcation Control

This submenu configures the following IO PCIe Port Bifurcation Control settings for IIO 1 PCIe ports to determine how the available PCI-Express lanes to be distributed between the PCI-Exp. Root Ports.

CPU1 Slot1 PCI-E 3.0 x8 Link Speed/ CPU1 Slot2 PCI-E 3.0 x8 Link Speed/ CPU1 Slot6 PCI-E 3.0 x8 Link Speed/CPU2 Slot3 PCI-E 3.0 x8 Link Speed/CPU2 Slot4 PCI-E 3.0 x8 Link Speed/CPU2 Slot5 PCI-E 3.0 x8 Link Speed

Select GEN1 for the device installed on the slot specified to support PCI-Exp Generation 1. Select GEN2 for the device installed on the slot specified to support PCI-Exp Generation 2. Select GEN3 for the device installed on the slot specified to support PCI-Exp Generation 3. The options are GEN1, GEN2, and **GEN3**.

IIO 2 PCIe Port Bifurcation Control

This submenu configures the following IO PCIe Port Bifurcation Control settings for IIO 2 PCIe ports to determine how the available PCI-Express lanes to be distributed between the PCI-Exp. Root ports.

►QPI Configuration

Current QPI Link

This item displays the current status of the QPI Link.

Current QPI Frequency

This item displays the frequency of the QPI Link.

Isoc

Select Enabled to enable Isochronous support to meet QoS (Quality of Service) requirements. This feature is especially important for virtualization technology. The options are Enabled and **Disabled**.

QPI (Quick Path Interconnect) Link Speed Mode

Use this feature to select data transfer speed for QPI Link connections. The options are Slow and **Fast**.

QPI Link Frequency Select

Use this feature to select the desired QPI frequency. The options are **Auto**, 6.4 GT/s, 7.2 GT/s, and 8.0 GT/s.

►DIMM Configuration

This section displays the following DIMM information.

Current Memory Mode

This item displays the current memory mode.

Current Memory Speed

This item displays the current memory speed.

Mirroring (Available when supported by the motherboard)

Memory mirroring creates a duplicate copy of the data stored in the memory to enhance data security.

Sparing (Available when supported by the motherboard)

Memory sparing enhances system reliability, availability, and serviceability.

► DIMM Information

CPU Socket 1 DIMM Information, CPU Socket 2 DIMM Information

The status of the memory modules detected by the BIOS will be displayed as detected by the BIOS.

Memory Mode

When Independent is selected, all DIMMs are available to the operating system. When Mirroring is selected, the motherboard maintains two identical copies of all data in memory for data backup. When Lock Step is selected, the motherboard uses two areas of memory to run the same set of operations in parallel. The options are **Independent**, Mirroring, and Lock Step.

DRAM RAPL Mode

RAPL (Running Average Power Limit) provides mechanisms to enforce power consumption limits on supported processors. The options are Disabled, DRAM RAPL MODE0, and **DRAM RAPL MODE1**.

DDR Speed

Use this feature to force a DDR3 memory module to run at a frequency other than what is specified in the specification. The options are Force DDR3-800, Force DDR3-1066, Force DDR3-1333, Force DDR3-1600 and Force SPD, and **Auto**.

Channel Interleaving

This feature selects from the different channel interleaving methods. The options are **Auto**, 1 Way, 2 Way, 3, Way, and 4 Way.

Rank Interleaving

This feature allows the user to select a rank memory interleaving method. The options are **Auto**, 1 Way, 2 Way, 4, Way, and 8 Way.

Patrol Scrub

Patrol Scrubbing is a process that allows the CPU to correct correctable memory errors detected on a memory module and send the correction to the requestor (the original source). When this item is set to Enabled, the IO hub will read and write back one cache line every 16K cycles, if there is no delay caused by internal processing. By using this method, roughly 64 GB of memory behind the IO hub will be scrubbed every day. The options are **Enabled** and Disabled.

Demand Scrub

Demand Scrubbing is a process that allows the CPU to correct correctable memory errors found on a memory module. When the CPU or I/O issues a demand-read command, and the read data from memory turns out to be a

correctable error, the error is corrected and sent to the requestor (the original source). Memory is updated as well. Select Enabled to use Demand Scrubbing for ECC memory correction. The options are Enabled and **Disabled**.

Data Scrambling

Select Enabled to enable data scrambling to ensure data security and integrity. The options are Disabled and **Enabled**.

Device Tagging

Select Enabled to support device tagging. The options are **Disabled** and Enabled.

Thermal Throttling

Throttling improves reliability and reduces power consumption in the processor via automatic voltage control during processor idle states. The options are Disabled and **CLTT** (Closed Loop Thermal Throttling).

► South Bridge Configuration

This feature allows the user to configure the settings for the Intel PCH chip.

PCH Information

This feature displays the following PCH information.

Name: This item displays the name of the PCH chip.

Stepping: This item displays the status of the PCH stepping.

USB Devices: This item displays the USB devices detected by the BIOS.

All USB Devices

This feature enables all USB ports/devices. The options are Disabled and **Enabled**. (If set to Enabled, EHCI Controller 1 and Controller 2 will appear.)

EHCI Controller 1/EHCI Controller 2 (Available when All USB Devices is set to Enabled)

Select Enabled to enable EHCI (Enhanced Host Controller Interface) Controller 1 or Controller 2. The options are Disabled and **Enabled**.

Legacy USB Support (Available when USB Functions is not Disabled)

Select Enabled to support legacy USB devices. Select Auto to disable legacy support if USB devices are not present. Select Disabled to have USB devices available for EFI (Extensive Firmware Interface) applications only. The settings are **Enabled**, Disabled, and Auto.

Port 60/64 Emulation

Select Enabled to enable I/O port 60h/64h emulation support for the legacy USB keyboard so that it can be fully supported by the operating systems that does not recognize a USB device. The options are Disabled and **Enabled**.

EHCI Hand-Off

This item is for operating systems that do not support Enhanced Host Controller Interface (EHCI) hand-off. When enabled, EHCI ownership change will be claimed by the EHCI driver. The options are **Disabled** and Enabled.

► SATA Configuration

When this submenu is selected, the AMI BIOS automatically detects the presence of IDE or SATA devices and displays the following items.

SATA Port0~SATA Port5: The AMI BIOS displays the status of each SATA port as detected by the BIOS.

SATA Mode

Use this feature to configure SATA mode for a selected SATA port. The options are Disabled, IDE Mode, **AHCI Mode** and RAID Mode. The following are displayed depending on your selection:

IDE Mode

The following items are displayed when IDE Mode is selected:

Serial-ATA (SATA) Controller 0~1

Use this feature to activate or deactivate the SATA controller, and set the compatibility mode. The options for SATA Controller 0 are Disabled, Enhanced, and **Compatible**. The options for SATA Controller 1 are Disabled and **Enhanced**.

AHCI Mode

The following items are displayed when the AHCI Mode is selected.

Aggressive Link Power Management

When Enabled, the SATA AHCI controller manages the power usage of the SATA link. The controller will put the link in a low power mode during extended periods of I/O inactivity, and will return the link to an active state when I/O activity resumes. The options are **Enabled** and Disabled.

Port 0-5 Hot Plug

Select Enabled to enable hot-plug support for a particular port, which will allow the user to change a hardware component or device without shutting down the system. The options are **Enabled** and Disabled.

Staggered Spin Up

Select Enabled to enable Staggered Spin-up support to prevent excessive power consumption caused by multiple HDDs spinning-up simultaneously. The options are Enabled and **Disabled**.

RAID Mode

The following items are displayed when RAID Mode is selected:

SATA RAID Option ROM

Use this feature to determine which SATA RAID device the system will boot from. The options are **Legacy** and EFI.

Port 0-5 Hot Plug

Select Enabled to enable hot-plug support for the particular port. The options are **Enabled** and Disabled.

► PCIe/PCI/PnP Configuration**PCI ROM Priority**

Use this feature to select the Option ROM to boot the system when there are multiple Option ROMs available in the system. The options are **Legacy ROM** and EFI Compatible ROM.

PCI Latency Timer

Use this feature to set the latency Timer of each PCI device installed on a PCI bus. Select 64 to set the PCI latency to 64 PCI clock cycles. The options are 32, **64**, 96, 128, 160, 192, 224 and 248.

Above 4G Decoding (Available if the system supports 64-bit PCI decoding)

Select Enabled to decode a PCI device that supports 64-bit in the space above 4G Address. The options are Enabled and **Disabled**.

PERR# Generation

Select Enabled to allow a PCI device to generate a PERR number for a PCI Bus Signal Error Event. The options are Enabled and **Disabled**.

SERR# Generation

Select Enabled to allow a PCI device to generate an SERR number for a PCI Bus Signal Error Event. The options are Enabled and **Disabled**.

Maximum Payload

Select Auto to allow the system BIOS to automatically set the maximum payload value for a PCI-E device to enhance system performance. The options are **Auto**, 128 Bytes and 256 Bytes.

Maximum Read Request

Select Auto to allow the system BIOS to automatically set the maximum Read Request size for a PCI-E device to enhance system performance. The options are **Auto**, 128 Bytes, 256 Bytes, 512 Bytes, 1024 Bytes, 2048 Bytes, and 4096 Bytes.

ASPM Support

This feature allows the user to set the Active State Power Management (ASPM) level for a PCI-E device. Select Force L0s to force all PCI-E links to operate at L0s state. Select Auto to allow the system BIOS to automatically set the ASPM level for the system. Select Disabled to disable ASPM support. The options are **Disabled**, Force L0s, and Auto.



Warning: Enabling ASPM support may cause some PCI-E devices to fail!

CPU1 Slot 1 PCI-E 3.0 x8 OPROM, CPU1 Slot 2 PCI-E 3.0 x8 OPROM, CPU2 Slot 3 PCI-E 3.0 x8 OPROM, CPU2 Slot 4 PCI-E 3.0 x8 OPROM, CPU2 Slot 5 PCI-E 3.0 x8 OPROM, CPU1 Slot 6 PCI-E 3.0 x 8 OPROM

Select Enabled to enable Option ROM support to boot the computer using a device installed on the slot specified above. The options are **Enabled** and Disabled.

Onboard LAN Option ROM Select

Select iSCSI to use the iSCSI Option ROM to boot the computer using a network device. Select PXE (Preboot Execution Environment) to use an PXE Option ROM to boot the computer using a network device. The options are **PXE** and iSCSI.

Load Onboard LAN1~LAN4 Option ROM

Select Enabled to enable the onboard LAN1 Option ROM~LAN4 Option ROM. This is to boot the computer using a network device. The default setting for LAN1 Option ROM is **Enabled**, and the default setting for LAN2~LAN4 Option ROM is **Disabled**.

Load Onboard SAS Option ROM

Select Enabled to use the onboard SAS Option ROM to boot the computer using a SAS device. The options are **Enabled** and Disabled.

VGA Priority

This feature allows the user to select the graphics adapter to be used as the primary boot device. The options are **Onboard**, and Offboard.

Network Stack

Select Enabled enable PXE (Preboot Execution Environment) or UEFI (Unified Extensible Firmware Interface) for network stack support. The options are Enabled and **Disabled**.

► Super IO Configuration

Super IO Chip: This item displays the Super IO chip used in the motherboard.

► Serial Port 1 Configuration

Serial Port

Select Enabled to enable serial port 1. The options are **Enabled** and Disabled.

Device Settings

This item displays the settings of Serial Port 1.

Change Settings

This option specifies the base I/O port address and the Interrupt Request address of Serial Port 1. Select Disabled to prevent the serial port from accessing any system resources. When this option is set to Disabled, the serial port becomes unavailable. The options are **Auto**, IO=3F8h; IRQ=4; IO=3F8h; IRQ=3, 4, 5, 6, 7, 9, 10, 11, 12; IO=2F8h; IRQ=3, 4, 5, 6, 7, 9, 10, 11, 12; IO=3E8h; IRQ=3, 4, 5, 6, 7, 9, 10, 11, 12; IO=2E8h, and IRQ=3, 4, 5, 6, 7, 9, 10, 11, 12.

Device Mode

Use this feature to select the desired mode for a serial port specified. The options are **Normal** and High Speed.

► Serial Port 2 Configuration

Serial Port

Select Enabled to enable serial port 2. The options are **Enabled** and Disabled.

Device Settings

This item displays the settings of Serial Port 2.

Change Settings

This option specifies the base I/O port address and the Interrupt Request address of Serial Port 2. Select Disabled to prevent the serial port from accessing any system resources. When this option is set to Disabled, the serial port becomes unavailable. The options are **Auto**, IO=3F8h; IRQ=4; IO=3F8h; IRQ=3, 4, 5, 6, 7, 9, 10, 11, 12; IO=2F8h; IRQ=3, 4, 5, 6, 7, 9, 10, 11, 12; IO=3E8h; IRQ=3, 4, 5, 6, 7, 9, 10, 11, 12; and IO=2E8h, and IRQ=3, 4, 5, 6, 7, 9, 10, 11, 12.

Device Mode

Use this feature to select the desired mode for a serial port specified. The options are **Normal** and High Speed.

Serial Port 2 Attribute

Use this feature to select the attribute for this serial port. The options are **SOL** (Serial Over LAN), and COM.

► Serial Port Console Redirection

COM1, COM2/SOL

These two submenus allow the user to configure the following Console Redirection settings for a COM Port specified by the user.

Console Redirection

Select Enabled to use a COM Port selected by the user for Console Redirection. The options are Enabled and Disabled. The default setting for COM1 is **Disabled**, and for COM2/SOL is **Enabled**.

► Console Redirection Settings

This feature allows the user to specify how the host computer will exchange data with the client computer, which is the remote computer used by the user.

Terminal Type

This feature allows the user to select the target terminal emulation type for Console Redirection. Select VT100 to use the ASCII Character set. Select VT100+ to add color and function key support. Select ANSI to use the Extended ASCII Character Set. Select VT-UTF8 to use UTF8 encoding to map Unicode characters into one or more bytes. The options are VT100, **VT100+**, VT-UTF8, and ANSI.

Bits Per second

Use this feature to set the transmission speed for a serial port used in Console Redirection. Make sure that the same speed is used in the host computer and the

client computer. A lower transmission speed may be required for long and busy lines. The options are 9600, 19200, 38400, 57600 and **115200** (bits per second).

Data Bits

Use this feature to set the data transmission size for Console Redirection. The options are 7 Bits and **8 Bits**.

Parity

A parity bit can be sent along with regular data bits to detect data transmission errors. Select Even if the parity bit is set to 0, and the number of 1's in data bits is even. Select Odd if the parity bit is set to 0, and the number of 1's in data bits is odd. Select None if you do not want to send a parity bit with your data bits in transmission. Select Mark to add a mark as a parity bit to be sent along with the data bits. Select Space to add a Space as a parity bit to be sent with your data bits. The options are **None**, Even, Odd, Mark and Space.

Stop Bits

A stop bit indicates the end of a serial data packet. Select 1 Stop Bit for standard serial data communication. Select 2 Stop Bits if slower devices are used. The options are **1** and 2.

Flow Control

This feature allows the user to set the flow control for Console Redirection to prevent data loss caused by buffer overflow. Send a "Stop" signal to stop sending data when the receiving buffer is full. Send a "Start" signal to start sending data when the receiving buffer is empty. The options are **None** and Hardware RTS/CTS.

VT-UTF8 Combo Key Support

Select Enabled to enable VT-UTF8 Combination Key support for ANSI/VT100 terminals. The options are **Enabled** and Disabled.

Recorder Mode

Select Enabled to capture the data displayed on a terminal and send it as text messages to a remote server. The options are **Disabled** and Enabled.

Resolution 100x31

Select Enabled for extended-terminal resolution support. The options are Disabled and **Enabled**.

Legacy OS Redirection Resolution

Use this feature to select the number of rows and columns used in Console Redirection for legacy OS support. The options are 80x24 and **80x25**.

Putty KeyPad

This feature selects Function Keys and KeyPad settings for Putty, which is a terminal emulator designed for the Windows OS. The options are **VT100**, LINUX, XTERMR6, SC0, ESCN, and VT400.

Serial Port for Out-of-Band Management/Windows Emergency Management Services (EMS)

The submenu allows the user to configure Console Redirection settings to support Out-of-Band Serial Port management.

Console Redirection (for EMS)

Select Enabled to use a COM Port selected by the user for Console Redirection. The options are Enabled and **Disabled**.

► Console Redirection Settings (for EMS)

This feature allows the user to specify how the host computer will exchange data with the client computer, which is the remote computer used by the user.

Out-of-Band Management Port

The feature selects a serial port used by the Microsoft Windows Emergency Management Services (EMS) to communicate with a remote server. The options are **COM1** and COM2/SOL.

Terminal Type

This feature allows the user to select the target terminal emulation type for Console Redirection. Select VT100 to use the ASCII character set. Select VT100+ to add color and function key support. Select ANSI to use the extended ASCII character set. Select VT-UTF8 to use UTF8 encoding to map Unicode characters into one or more bytes. The options are ANSI, VT100, **VT100+**, and VT-UTF8.

Bits Per Second

This item sets the transmission speed for a serial port used in Console Redirection. Make sure that the same speed is used in the host computer and the client computer. A lower transmission speed may be required for long and busy lines. The options are 9600, 19200, 57600, and **115200** (bits per second).

Flow Control

This feature allows the user to set the flow control for Console Redirection to prevent data loss caused by buffer overflow. Send a "Stop" signal to stop sending data when the receiving buffer is full. Send a "Start" signal to start sending data when the receiving buffer is empty. The options are **None**, Hardware RTS/CTS, and Software Xon/Xoff.

Data Bits, Parity, Stop Bits

The status of these features is displayed.

►ACPI Settings

Use this feature to configure Advanced Configuration and Power Interface (ACPI) power management settings for your system.

ACPI Sleep State

Use this feature to select the ACPI State when the system is in sleep mode. Select S1 (CPU_Stop_Clock) to erase all CPU caches and stop executing instructions. Power to the CPU(s) and RAM is maintained, but RAM is refreshed. Select Suspend Disabled to use power-reduced mode. Power will only be supplied to limited components (such as RAMs) to maintain the most critical functions of the system. The options are Suspend Disabled and **S1 (CPU_Stop_Clock)**.

NUMA (NON-Uniform Memory Access)

This feature enables the Non-Uniform Memory Access ACPI support. The options are **Enabled** and Disabled.

High Precision Event Timer

Select Enabled to activate the High Precision Event Timer (HPET) that produces periodic interrupts at a much higher frequency than a Real-time Clock (RTC) does in synchronizing multimedia streams, providing smooth playback, reducing the dependency on other timestamp calculation devices, such as an x86 RDTSC Instruction embedded in the CPU. The High Performance Event Timer is used to replace the 8254 Programmable Interval Timer. The options are **Enabled** and Disabled.

►Trusted Computing (Available when a TPM device is detected by the BIOS)

Configuration

TPM Support

Select Enabled on this item and enable the TPM jumper on the motherboard to enable TPM support to improve data integrity and network security. The options are **Enabled** and Disabled.

TPM State

Select Enabled to enable TPM security settings to improve data integrity and network security. The options are Disabled and **Enabled**.

Pending Operation

Use this item to schedule an operation for the security device. The options are **None**, Enable Take Ownership, Disable Take Ownership, and TPM Clear.

 **Note:** During restart, the computer will reboot in order to execute the pending operation and change the state of the security device.

Current Status Information: This item displays the information regarding the current TPM status.

TPM Enable Status

This item displays the status of TPM Support to indicate if TPM is currently enabled or disabled.

TPM Active Status

This item displays the status of TPM Support to indicate if TPM is currently active or deactivated.

TPM Owner Status

This item displays the status of TPM Ownership.

► Intel TXT (LT-SX) Configuration

Intel TXT (LT-SX) Hardware Support

This feature indicates if the following hardware components support the Intel Trusted Execution Technology.

CPU: TXT (Trusted Execution Technology) Feature

Chipset: TXT (Trusted Execution Technology) Feature

Intel TXT (LT-SX) Configuration

This feature displays the following TXT configuration setting.

TXT (LT-SX) Support: This item indicates if the Intel TXT support is enabled or disabled. The default setting is **Disabled**.

Intel TXT (LT-SX) Dependencies

This feature displays the features that need to be enabled for the Intel Trusted Execution Technology to work properly in the system.

VT-d Support: Intel Virtualization Technology with Direct I/O support

VT Support: Intel Virtualization Technology support

TPM Support: Trusted Platform support

TPM State: Trusted Platform state

► ME Subsystem

This feature displays the following ME Subsystem Configuration settings.

- **ME BIOS Interface Version**
- **ME Version**

iSCSI Configuration: This item displays iSCSI configuration information:

iSCSI Initiator Name

This item displays the name of the iSCSI Initiator, which is a unique name used in the world. The name must use IQN format. The following actions can also be performed:

- Add an Attempt
- Delete Attempts
 - Commit/Discard Changes and Exit
- Change Attempt Order
 - Commit/Discard Changes and Exit

Intel® Ethernet Controller I350 Gigabit Network Connection: These items display the following information on the Intel I350 Gigabit network connections.

► NIC Configuration

Link Speed

Use this feature to change the link speed and duplex for the current port. The options are **AutoNeg**, 10Mbps Half, 10Mbps Full, 100Mbps Half, and 100Mbps full.

Wake on LAN

Select enabled to wake the system with a magic packet. The options are **Enabled** and Disabled.

Blink LEDs

This feature allows the user to specify the duration for LEDs to blink. The range is from 0 ~ 15 seconds. The default setting is **0**.

PORT CONFIGURATION INFORMATION

This section displays the following port information:

- UEFI Driver
- Adapter PBA
- Chip Type
- PCI Device ID
- PCI Bus:Device:Function
- Link Status
- Factory MAC Address / Alternate MAC Address

7-4 Event Logs

Select the Event Logs tab to access the following submenu items.

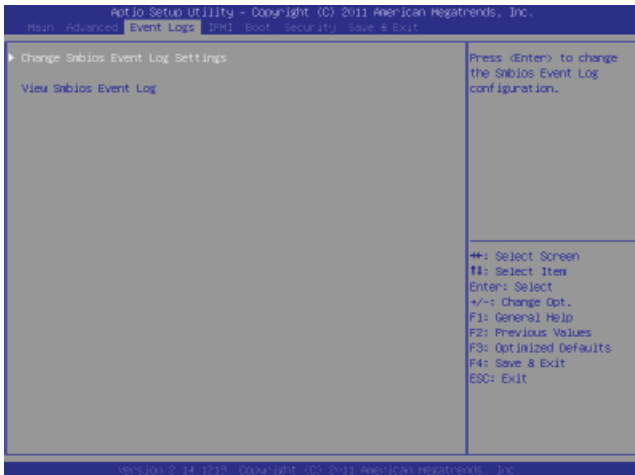

► Change SMBIOS Event Log Settings

This feature allows the user to configure SMBIOS Event settings.

Enabling/Disabling Options

SMBIOS Event Log

Select Enabled to enable SMBIOS (System Management BIOS) Event Logging during system boot. The options are **Enabled** and Disabled.

Runtime Error Logging Support

Select Enabled to support Runtime Error Logging. The options are **Enabled** and Disabled.

Memory Correctable Error Threshold

This feature allows the user to enter the threshold value for correctable memory errors. The default setting is **10**.

PCI Error Logging Support

Select Enabled to support error event logging for PCI slots. The options are Enabled and **Disabled**.

Erasing Settings

Erase Event Log

Select Enabled to erase the SMBIOS (System Management BIOS) Event Log, which is completed before a event logging is initialized upon system reboot. The options are **No**, Yes, Next reset, and Yes, Every reset.

When Log is Full

Select Erase Immediately to immediately erase SMBIOS error event logs that exceed the limit when the SMBIOS event log is full. Select Do Nothing for the system to do nothing when the SMBIOS event log is full. The options are **Do Nothing** and Erase Immediately.

SMBIOS Event Log Standard Settings

Log System Boot Event

Select Enabled to log system boot events. The options are **Disabled** and Enabled.

MECI (Multiple Event Count Increment)

Enter the increment value for the multiple event counter. Enter a number from 1 to 255. The default setting is **1**.

METW (Multiple Event Count Time Window)

This item allows the user to decide how long (in minutes) should the multiple event counter wait before generating a new event log. Enter a number from 0 to 99. The default setting is **60**.

View SMBIOS Event Log

This item allows the user to view the event in the SMBIOS event log. Select this item and press <Enter> to view the status of an event in the log.

Date/Time/Error Code/Severity

7-5 IPMI

Select the IPMI (Intelligent Platform Management Interface) tab to access the following submenu items.



IPMI Firmware Revision

This item indicates the IPMI firmware revision used in your system.

IPMI Status

This item indicates the status of the IPMI firmware installed in your system.

▶ System Event Log

Enabling/Disabling Options

SEL Components

Select Enabled for all system event logging at bootup. The options are **Enabled** and Disabled.

Erasing Settings

Erase SEL

Select Yes, On next reset to erase all system event logs upon next system reboot.
 Select Yes, On every reset to erase all system event logs upon each system reboot.
 Select No to keep all system event logs after each system reboot. The options are **No**, **Yes, On next reset**, and **Yes, On every reset**.

When SEL is Full

This feature allows the user to decide what the BIOS should do when the system event log is full. Select Erase Immediately to erase all events in the log when the system event log is full. The options are **Do Nothing** and Erase Immediately.

Custom EFI Logging Options

Log EFI Status Codes

Select Enabled to log EFI (Extensible Firmware Interface) Status Codes, Error Codes or Progress Codes. The options are **Enabled** and Disabled.

 **Note:** After making changes on a setting, be sure to reboot the system for the changes to take effect.

►BMC Network Configuration

LAN Channel 1: This feature allows the user to configure the settings for LAN1 Port.

Update IPMI LAN Configuration

This feature allows the BIOS to implement any IP/MAC address changes at the next system boot. If the option is set to Yes, any changes made to the settings below will take effect when the system is rebooted. The options are **No** and Yes.

Configuration Address Source

This feature allows the user to select the source of the IP address for this computer. If Static is selected, you will need to know the IP address of this computer and enter it to the system manually in the field. If DHCP is selected, the BIOS will search for a DHCP (Dynamic Host Configuration Protocol) server in the network that is attached to and request the next available IP address for this computer. The options are **DHCP** and Static. The following items are assigned IP addresses automatically if DHCP is selected, or can be configured manually if Static is selected.

Station IP Address

This item displays the Station IP address for this computer. This should be in decimal and in dotted quad form (i.e., 192.168.10.253).

Subnet Mask

This item displays the sub-network that this computer belongs to. The value of each three-digit number separated by dots should not exceed 255.

Station MAC Address

This item displays the Station MAC address for this computer. Mac addresses are 6 two-digit hexadecimal numbers.

Gateway IP Address

This item displays the Gateway IP address for this computer. This should be in decimal and in dotted quad form (i.e., 192.168.10.253).

7-6 Boot

This submenu allows the user to configure the following boot settings for the system.

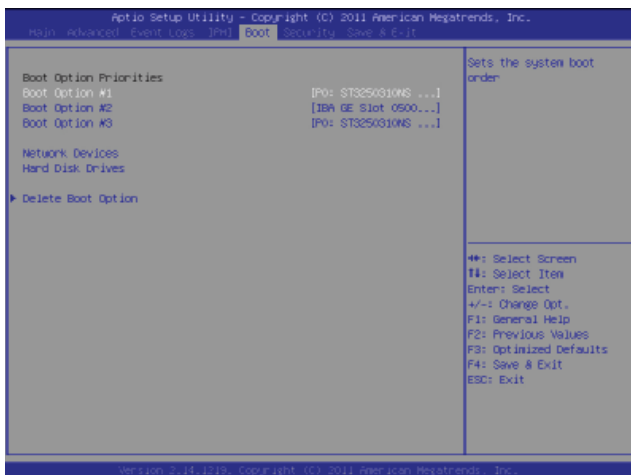

Boot Option Priorities

Boot Option #1, Boot Option #2, Boot Option #3, etc.

Use this feature to specify the sequence of boot device priority.

Network Devices, Hard Disk Drives

Use these options to set the order of the legacy network and hard drive devices detected by the motherboard.

▶ Delete Boot Option

This feature allows the user to select a EFI boot device to delete from the boot priority list.

Delete Boot Option

Select the desired boot device to delete.

7-7 Security

This menu allows the user to configure the following security settings for the system.



Password Check

Use this feature to determine when a password entry is required. Select Setup to require the password only when entering setup. Select Always to require the password when entering setup and on each boot. The options are **Setup** and **Always**.

Administrator Password

Use this feature to set the Administrator Password which is required to enter the BIOS setup utility. The length of the password should be from 3 to 20 characters long.

7-8 Save & Exit

This submenu allows the user to configure the Save and Exit settings for the system.

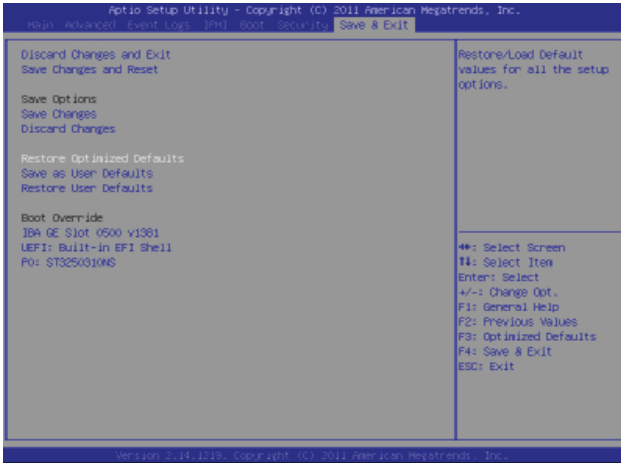

Discard Changes and Exit

Select this option to quit the BIOS Setup without making any permanent changes to the system configuration, and reboot the computer. Select Discard Changes and Exit, and press <Enter>. When the dialog box appears, asking you if you want to exit the BIOS setup without saving, select **Yes** to quit BIOS without saving the changes, or select No to quit the BIOS and save changes.

Save Changes and Reset

When you have completed the system configuration changes, select this option to save the changes and reboot the computer so that the new system configuration settings can take effect. Select Save Changes and Exit, and press <Enter>. When the dialog box appears, asking you if you want to exit the BIOS setup without saving, select **Yes** to quit BIOS without saving the changes, or select No to quit the BIOS and save changes.

Save Options

Save Changes

Select this option and press <Enter> to save all changes you've done so far and return to the AMI BIOS utility Program. When the dialog box appears, asking you if you want to save configuration, select **Yes** to save the changes, or select No to return to the BIOS without making changes.

Discard Changes

Select this feature and press <Enter> to discard all the changes and return to the BIOS setup. When the dialog box appears, asking you if you want to load previous values, select **Yes** to load the values previous saved, or select No to keep the changes you've made so far.

Restore Optimized Defaults

Select this feature and press <Enter> to load the optimized default settings that help optimize system performance. When the dialog box appears, asking you if you want to load optimized defaults, select **Yes** to load the optimized default settings, or select No to abandon optimized defaults.

Save as User Defaults

Select this feature and press <Enter> to save the current settings as the user's defaults. When the dialog box appears, asking you if you want to save values as user's defaults, select **Yes** to save the current values as user's default settings, or select No to keep the defaults previously saved as the user's defaults.

Restore User Defaults

Select this feature and press <Enter> to load the user's defaults previously saved in the system. When the dialog box appears, asking you if you want to restore user's defaults, select **Yes** to restore the user's defaults previously saved in the system, or select No to abandon the user's defaults that were previously saved.

Boot Override

This feature allows the user to override the Boot Option Priorities setting in the Boot menu, and instead boot the system with one of the listed devices. This is a one-time override.

Appendix A

BIOS Error Beep Codes

During the POST (Power-On Self-Test) routines, which are performed at each system boot, errors may occur.

Non-fatal errors are those which, in most cases, allow the system to continue to boot. The error messages normally appear on the screen.

Fatal errors will not allow the system to continue with bootup procedure. If a fatal error occurs, you should consult with your system manufacturer for possible repairs.

These fatal errors are usually communicated through a series of audible beeps. The numbers on the fatal error list correspond to the number of beeps for the corresponding error.

BIOS Error Beep Codes		
Beep Code/LED	Error Message	Description
1 beep	Refresh	Ready to boot
5 short beeps + 1 long beep	Memory error	No memory detected in the system
5 beeps	No Con-In or No Con-Out devices	Con-In: USB or PS/2 keyboard, PCI or Serial Console Redirection, IPMI KVM or SOL Con-Out: Video Controller, PCI or Serial Console Redirection, IPMI SOL
X9 IPMI Error Codes		
1 Continuous Beep	System OH	System Overheat

Notes

Appendix B

System Specifications

Processors

Single or dual Intel® Xeon E5-2600 Series processors

Note: Please refer to our web site for a complete listing of supported processors.

Chipset

Intel C602J chipset

BIOS

128 Mb AMI® SPI Flash ROM

Memory Capacity

Sixteen DIMM sockets supporting up to 512 GB of registered ECC DDR3-1333/1066/800 Registered memory (RDIMM) or up to 128 GB of ECC/non-ECC DDR3 Unbuffered memory (UDIMM)

Note: see Section 5-6 for details.

Drive Bays

Sixteen hot-swap drive bays to house SATA drives

Peripheral Drive Bays

One slim DVD-ROM drive

Expansion Slots

6x PCI-E x8 slots

Serverboard

X9DRD-7LN4F-JBOD (Extended ATX form factor)

Dimensions: 13.68 x 13 in (347 x 330 mm)

Chassis

SC836S2-R920B, 3U rackmount

Dimensions: (WxHxD) 17.2 x 5.2 x 25.5 in. (437 x 132 x 648 mm)

Weight

Gross (Bare Bone): 78 lbs. (35.5 kg.)

System Cooling

Three 8-cm system fans

Two 8-cm exhaust fans

One air shroud

System Input Requirements

AC Input Voltage: 100 - 240V AC auto-range

Rated Input Current: 13 - 4A max

Rated Input Frequency: 50 to 60 Hz

Power Supply

Rated Output Power: 920W (Part# PWS-920P-1R)

Rated Output Voltages: +12V (75A), +5Vsb (4A)

Operating Environment

Operating Temperature: 10° to 35° C (32° to 95° F)

Non-operating Temperature: -40° to 70° C (-40° to 158° F)

Operating Relative Humidity: 20% to 95% (non-condensing)

Non-operating Relative Humidity: 5% to 95% (non-condensing)

Regulatory Compliance

Electromagnetic Emissions: FCC Class A, EN 55022 Class A, EN 61000-3-2/-3-3, CISPR 22 Class A

Electromagnetic Immunity: EN 55024/CISPR 24, (EN 61000-4-2, EN 61000-4-3, EN 61000-4-4, EN 61000-4-5, EN 61000-4-6, EN 61000-4-8, EN 61000-4-11)

Safety: CSA/EN/IEC/UL 60950-1 Compliant, UL or CSA Listed (USA and Canada), CE Marking (Europe)

California Best Management Practices Regulations for Perchlorate Materials:

This Perchlorate warning applies only to products containing CR (Manganese Dioxide) Lithium coin cells. "Perchlorate Material-special handling may apply. See www.dtsc.ca.gov/hazardouswaste/perchlorate"

(continued from front)

The products sold by Supermicro are not intended for and will not be used in life support systems, medical equipment, nuclear facilities or systems, aircraft, aircraft devices, aircraft/emergency communication devices or other critical systems whose failure to perform be reasonably expected to result in significant injury or loss of life or catastrophic property damage. Accordingly, Supermicro disclaims any and all liability, and should buyer use or sell such products for use in such ultra-hazardous applications, it does so entirely at its own risk. Furthermore, buyer agrees to fully indemnify, defend and hold Supermicro harmless for and against any and all claims, demands, actions, litigation, and proceedings of any kind arising out of or related to such ultra-hazardous use or sale.