

Information for Lot 9 of ErP (Ecodesign)

This addendum addresses European Union (EU) Ecodesign requirements for servers and storage products. All data and ratings within this addendum are in reference only to the Supermicro product(s) in the manual. The below information conforms to requirements laid down in Annex II of the Commission Regulation 2019/424.

- 3(1)(a): See Section 1.1 of the system manual for the product type.
- 3(1)(b): See the title page and preface of the system manual for the trademark and manufacturer's address.
- 3(1)(c): See the title page of the system manual for product model number(s).
- 3(1)(d): See the serial number on the physical system to determine the year of manufacture.
- 3(1)(e-j): **PSU Efficiency and Power Factor Value (Table) (From 80 Plus report)**

PWS-2K05A-1R 2000 WATTS	PSU Efficiency				Power Factor
	10 %	20 %	50 %	100 %	50 %
Single Output (AC-DC)	90%	94%	96%	91%	>0.95%

System (EUT) Efficiency in Idle State Power (Table)

Representative Configurations	Measured Idle State Power (W)	Calculated Idle Power Allowance (W)
High-End Performance Configuration	278.8	584.331
Typical Configuration	N/A	N/A
Low-End Performance Configuration	191.5	259.287

System (EUT) Efficiency in Active State Power (Table)

Representative Configurations	Active State Efficiency Score (Effserver)	Minimum Active State Efficiency for 2-Socket Server
High-End Performance Configuration	15.0	5.7
Typical Configuration	N/A	
Low-End Performance Configuration	10.5	

3(1)(k): The operating condition class is **A2**.

Operating condition	Dry bulb temp °C		Humidity range, non-condensing		Max dew point (°C)	Maximum rate of change
	Allowable range	Recommend - mend	Allowable range	Recommended range		
A1	15- 32	18-27	- 12 °C Dew Point (DP) and 8 % relative humidity (RH) to 17 °C DP and 60 % RH	- 9 °C DP to 15 °C DP and 60 %	17	5/20
A2	10-35	18-27	- 12 °C DP and 8 % RH to 21 °C DP and 80 %	Same as A1	21	5/20
A3	5-40	18-27	- 12 °C DP and 8 % RH to 24 °C DP and 85 %	Same as A1	24	5/20
A4	5-45	18-27	- 12 °C DP and 8 % RH to 24 °C DP and 90 %	Same as A1	24	5/20

3(1)(l): The idle state power at the higher boundary temperature of the operating conditions class is 523.4W.

3(1)(m): The active state efficiency and performance is 15

3(1)(n): There are two methods by which a user can securely delete data from this system. The user performing secure data deletion should be an IT professional.

The first is with a Unified Extensible Firmware Interface (UEFI) shell utility. This utility works on X10/X11/H11/H12/M11 motherboard series with onboard SATA/NVMe devices. Any user may access and download this utility through following link:

https://www.supermicro.com/about/policies/disclaimer.cfm?url=/wftp/utility/Lot9_Secure_Data_Deletion_UTILITY/

Download the shell utility package and extract it to a USB flash drive, then plug the drive into the server for which secure data deletion is necessary. Then turn the system on. Navigate to the BIOS setup menu, then place the server system into the UEFI shell environment. Follow the instructions in the README file to invoke the utility and complete the deletion.

The second method is through the secure data deletion tool provided by the original manufacturer of the hard drive. This should be used in a scenario where the shell utility is not applicable. Each manufacturer should have the tool available on their website. If needed, please look on the hard drive label for the name of the manufacturer and model information.

3(1)(o): List of recommended combinations of blade servers with chassis: N/A.

3(1)(p): List of all current SKUs within this product family: N/A.

3(3)(a): There is no use of cobalt in batteries in this product.

The indicative weight range of neodymium in the HDD is 0.0 if manufactured by Western Digital, and is between 5-25 grams if manufactured by Seagate.

3(3)(b): Please see the disassembly instructions on the next page.

Illustrated System Disassembly Instructions

Please note: All the illustrations in the below disassembly instructions are for demonstration only. Components shown here may not match exactly with the components in your system.

CAUTION: Always power off the system and unplug the power cord(s) first before disassembling the system!

1. Memory

Type and number of fastenings: Two (2) latches per memory module.

Tools required: None.

Procedure: Press both release tabs on the ends of the memory module to unlock it. Once the module is loosened, remove it from the memory slot.

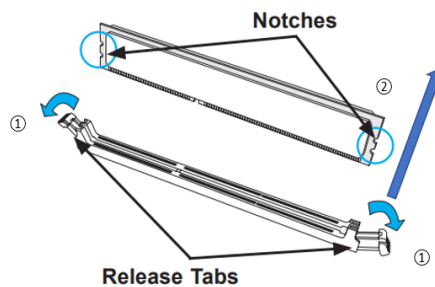

2. Processor

Type and number of fastenings: Four (4) T30 Torx screws.

Tools required: Screwdriver with T30 Torx bit.

Procedure: Remove the screws in the sequence of 4, then 3, then 2, then 1, as marked in the illustration below. After removing the screws, lift the processor heatsink module off the processor socket. Unsnap corners A and B, then C and D of the latch. Push the latch out from the bottom.

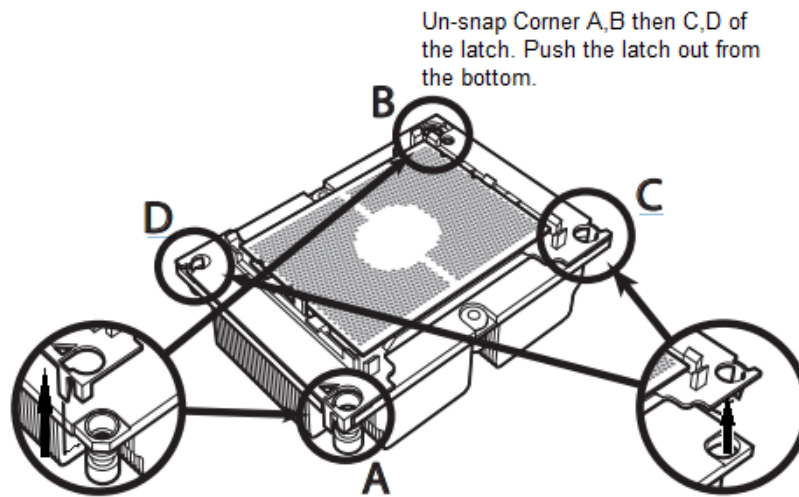
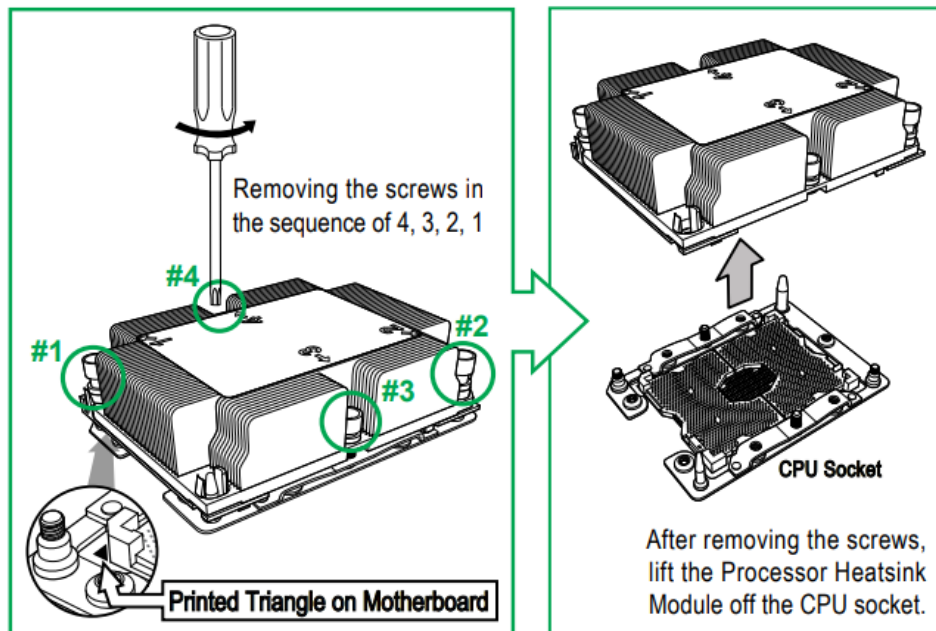

3. Batteries

Type and number of fastenings: One (1) latch.

Tools required: None.

Procedure: Push aside the small clamp that covers the edge of the battery. When the battery is released, lift it out of the holder.

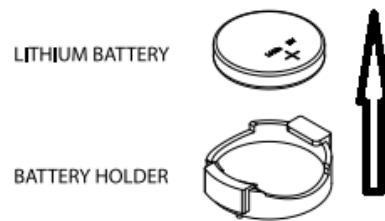

4. Removing Chassis from Rack

Type and number of fastenings: None.

Tools required: None.

Procedure: Pull the chassis forward out the front of the rack until it stops. Press the release latches on each of the inner rails downward simultaneously and move the chassis forward in the rack.

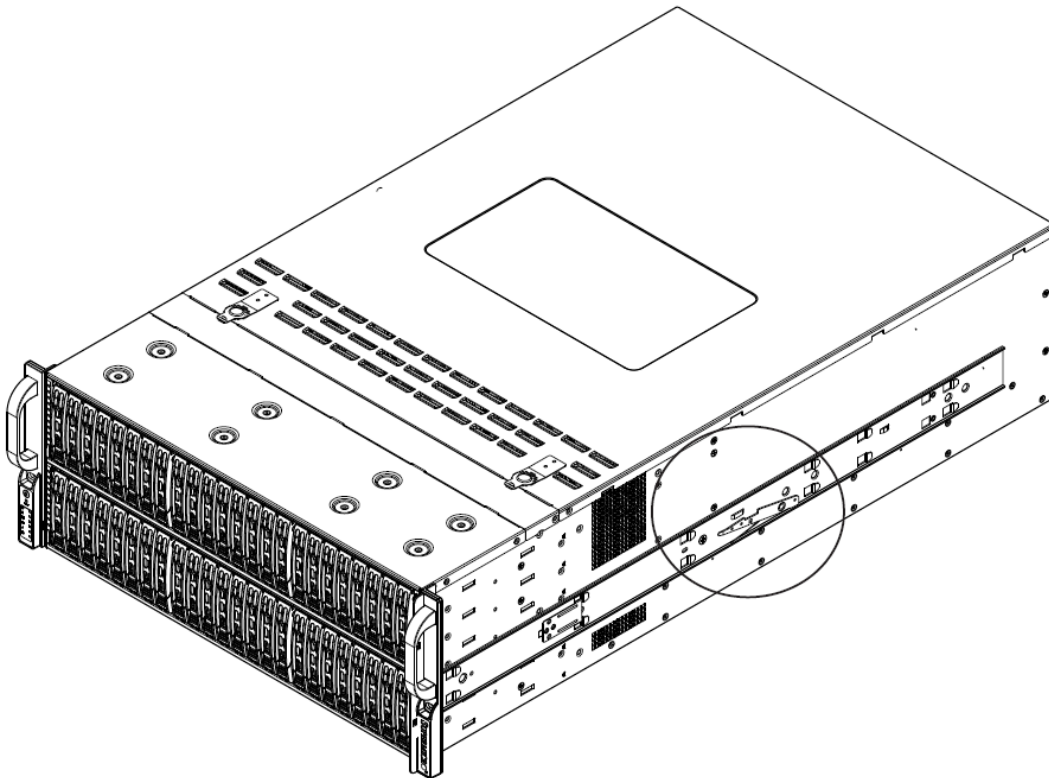

5. Chassis Cover

Type and number of fastenings: Two (2) Phillips screws.

Tools required: Screwdriver with PH2 bit.

Procedure: Remove the screws located on the chassis, as indicated below. Press down on the lid release buttons and slide the lid toward the rear of the system. Lift the lid from the chassis.

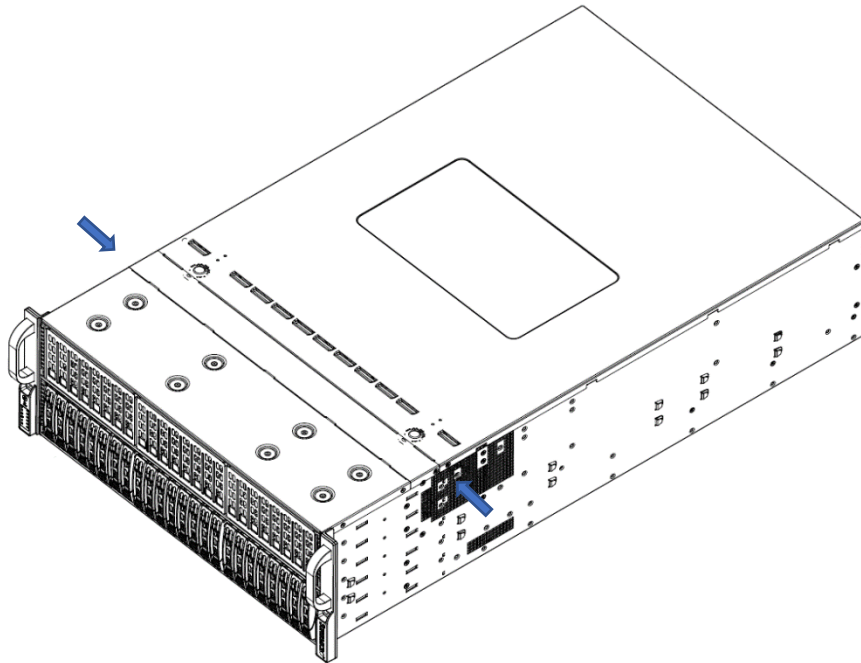

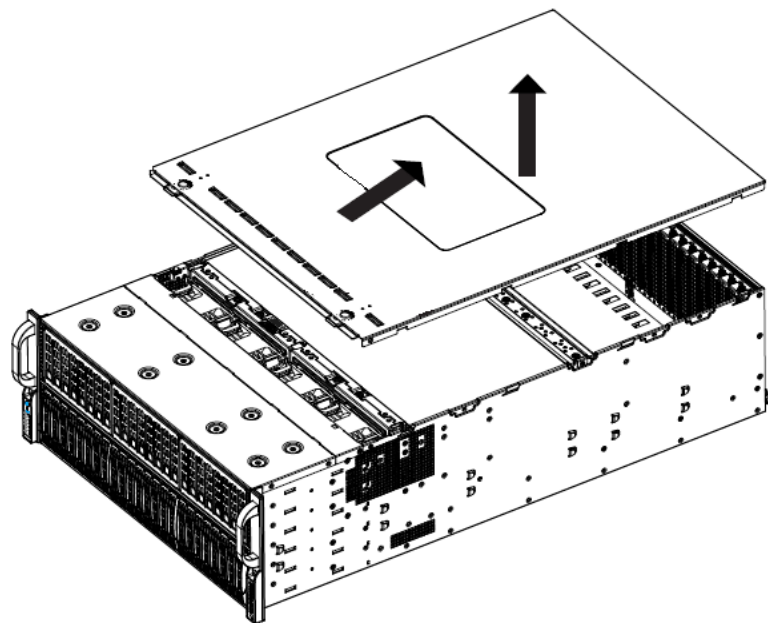

6. Fans

Type and number of fastenings: None.

Tools required: None.

Procedure: (The system contains eight system fans that provide cooling for the system. All fans are hot-swappable, and there is no need to power down the system when removing and/or replacing the system fans. If necessary, open the chassis while the power is running to determine which fan has failed.) Press the fan housing lever to unlock the fan from the fan bracket. While applying pressure to the fan housing lever, gently pull the fan upward to remove it.

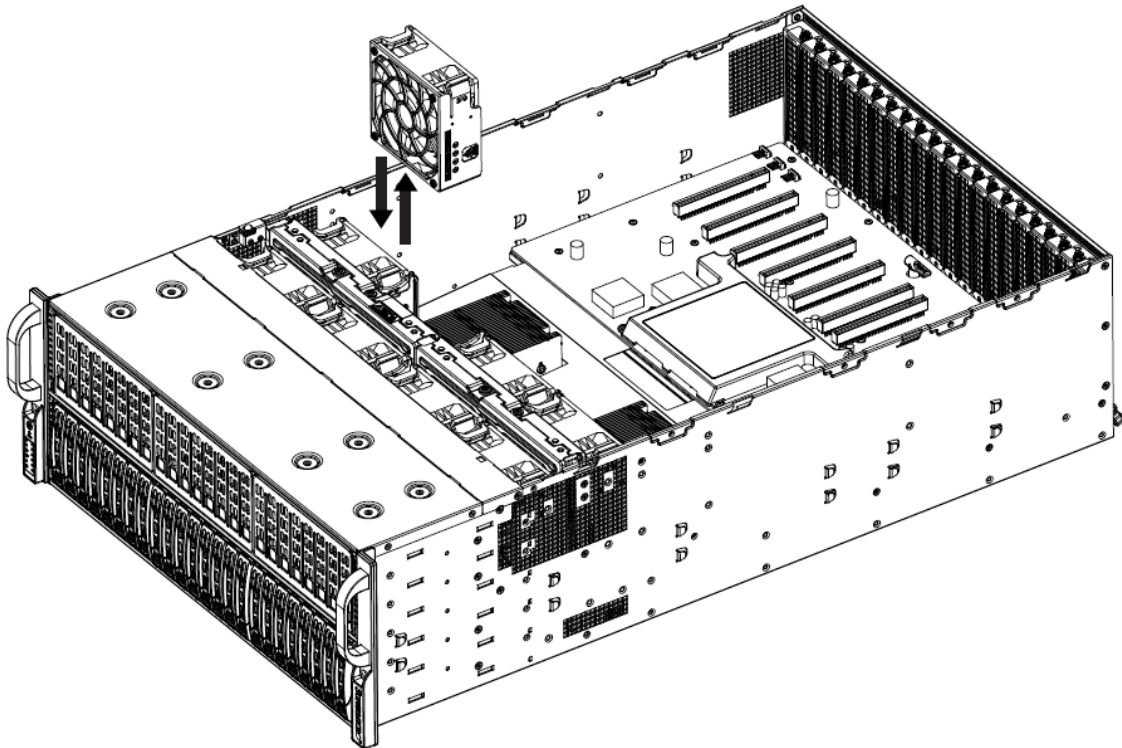

7. Fan Cage Assembly

Type and number of fastenings: Two (2) Phillips screws.

Tools required: Screwdriver with PH2 bit.

Procedure: Remove the two screws, as indicated below. Carefully remove the entire fan cage assembly from chassis. Disconnect the fan power cables from the motherboard.

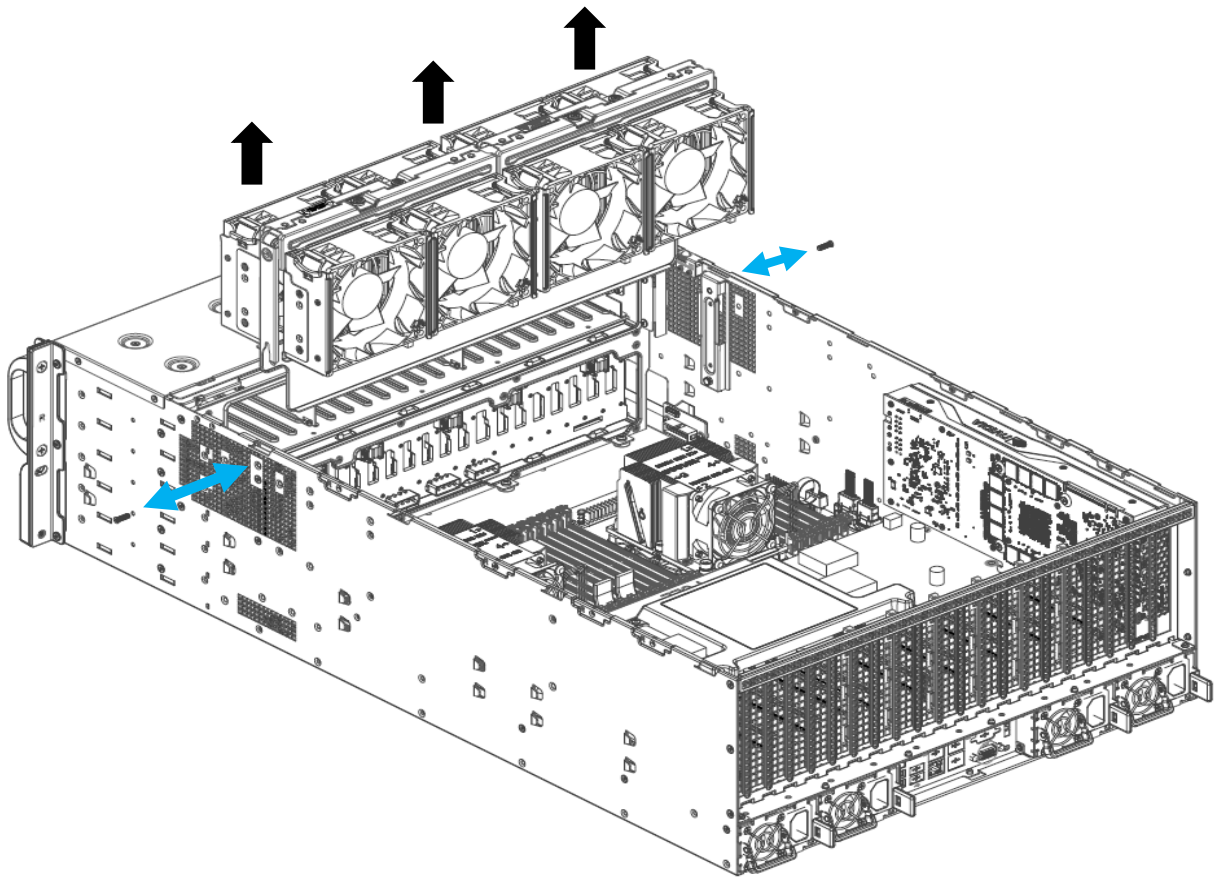

8. PCI-E Board Assembly

Type and number of fastenings: Ten (10) Phillips screws.

Tools required: Screwdriver with PH2 bit.

Procedure: Remove the ten screws from the PCI-E board. (Please note to only remove the screws with *SCREWDRIVER* silkscreened next to it. The screw locations are marked in blue below.) Gently pull up on the lever located in front of the PCI-E board assembly to disconnect the PCI-E board from the motherboard. Hold the PCI-E board assembly front lever and rear finger lever (marked in red below) and gently pull the PCI-E board assembly out of the system.

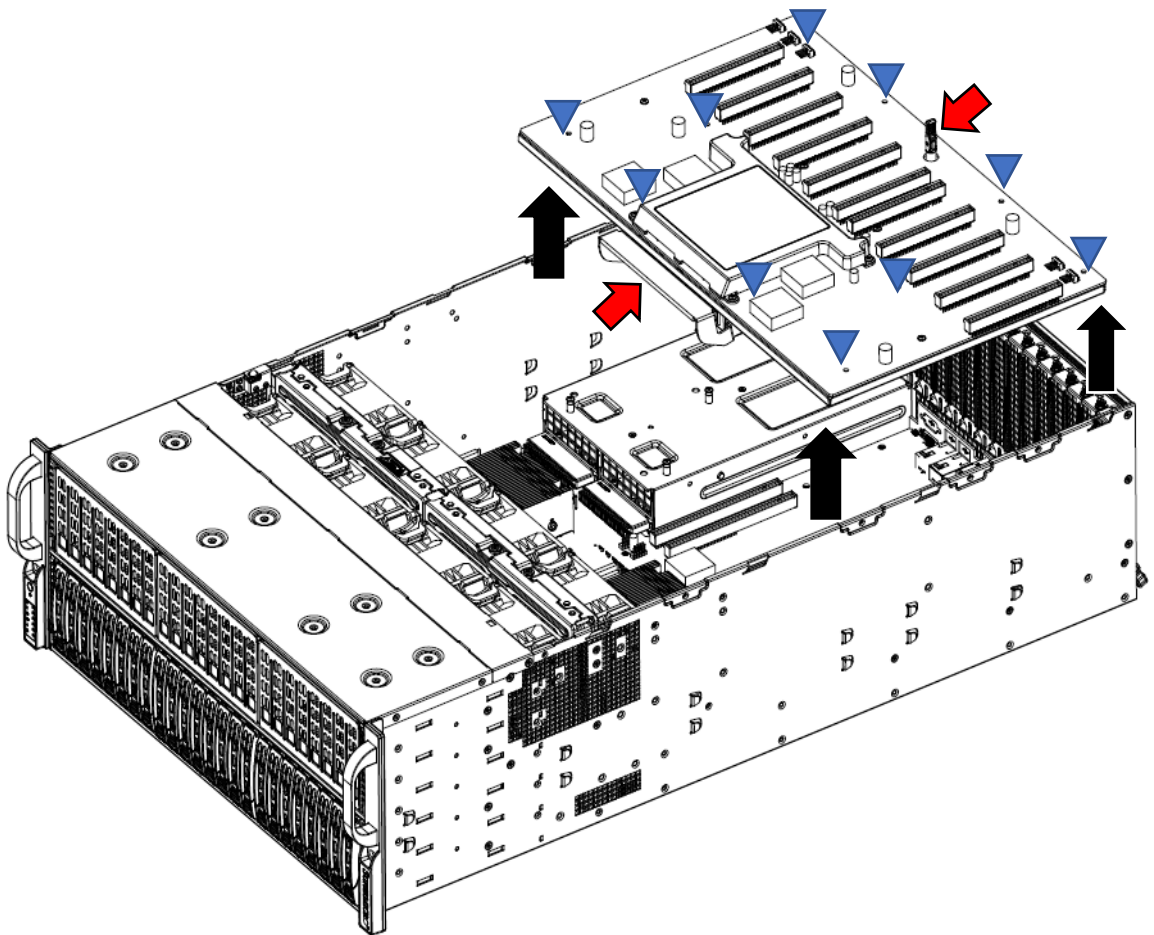

9. Riser Card

Type and number of fastenings: Eight (8) Phillips screws.

Tools required: Screwdriver with PH2 bit.

Procedure: Carefully turn the PCI-E board assembly over and remove the eight screws. Lift up the riser card cage from the PCI-E board assembly. Remove the four riser cards from the PCI-E board.

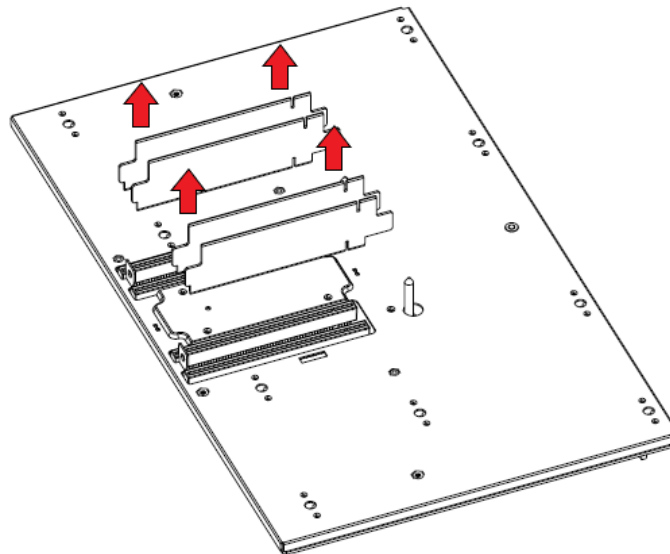
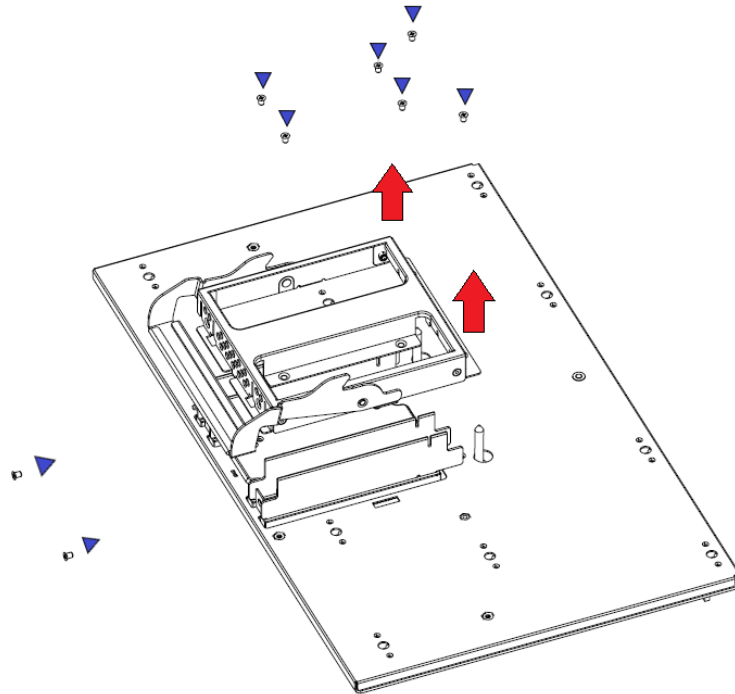

10. PCI-E Board

Type and number of fastenings: Six (6) Phillips screws.

Tools required: Screwdriver with PH2 bit.

Procedure: Remove the six screws. Lift up the black plastic palm cover (yellow arrows). Carefully lift the PCI-E board by the edge from the PCI-E board assembly base plate.

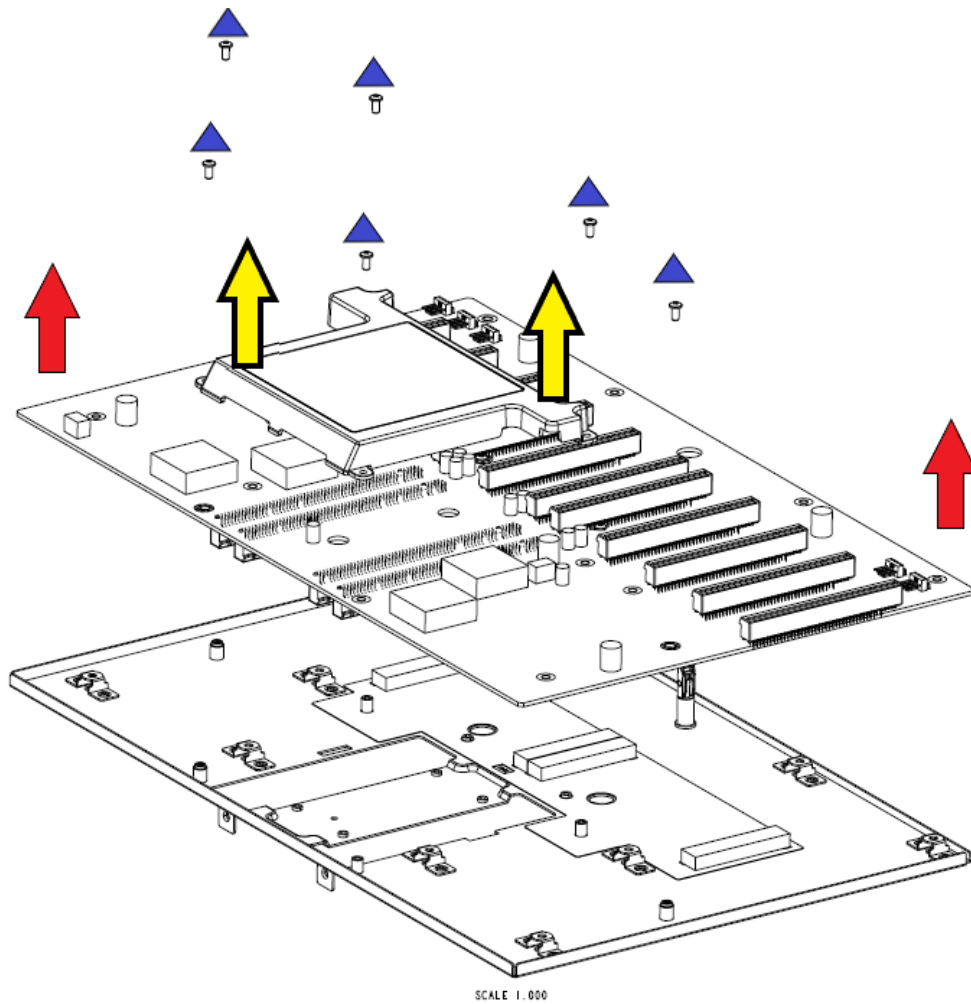

11. Power Supply Module

Type and number of fastenings: None.

Tools required: None.

Procedure: Unplug the AC power cord from the power supply module. Push and hold the release tab on the back of the power supply module. Hold the module handle and pull the module out of its bay.

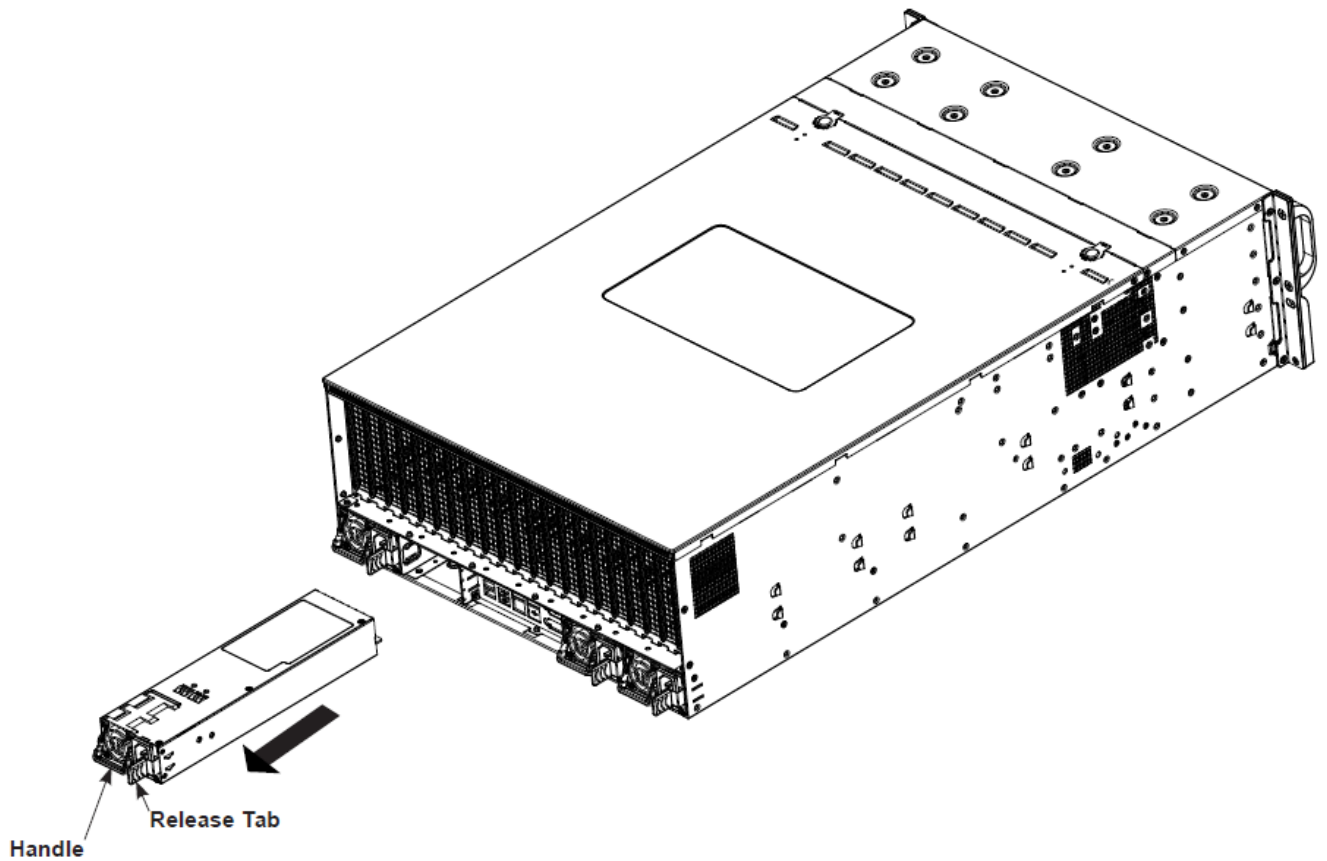

12. Motherboard

Type and number of fastenings: Twelve (12) Phillips screws.

Tools required: Screwdriver with PH2 bit.

Procedure: Remove the fan cage assembly and disconnect all cables. Remove the four power supplies from the system. Remove twelve screws, as indicated by the blue arrows below. Holding the edge of motherboard, carefully lift the motherboard from the chassis.

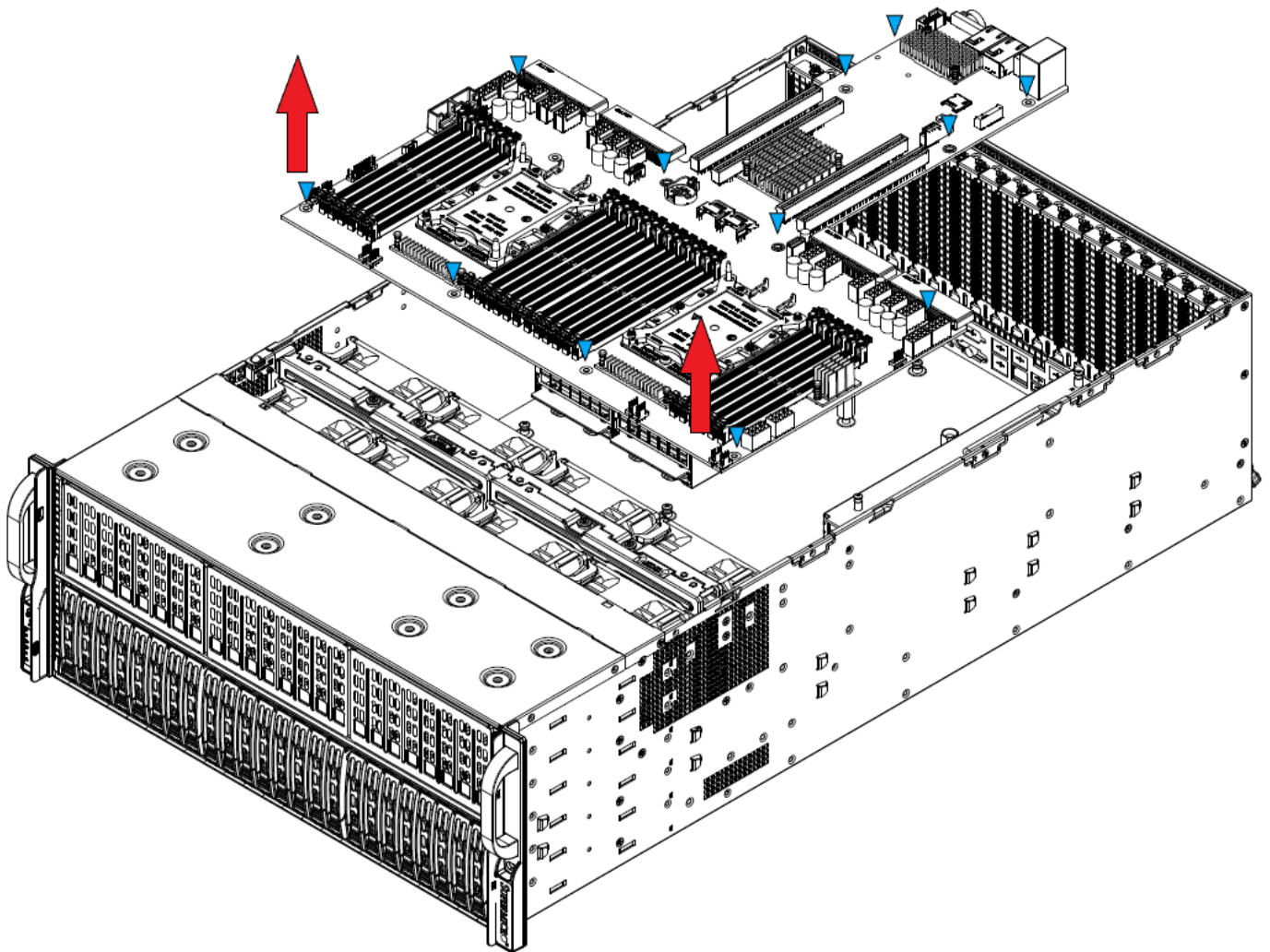

13. Hard Drives

Type and number of fastenings: Four (4) screws per carrier.

Tools required: Screwdriver with PH2 bit.

Procedure: Press the release button on the drive carrier. This extends the drive carrier handle. Use the handle to pull the hard drive and its carrier out of the chassis. Remove four screws, as illustrated below. Remove the hard drive from the carrier.

