

## Information for Lot 9 of ErP (Ecodesign)

For SYS-4028GR-TXRT

This addendum addresses European Union (EU) Ecodesign requirements for servers and storage products. All data and ratings within this addendum are in reference only to the Supermicro product(s) in the manual. The below information conforms to requirements laid down in Annex II of the Commission Regulation 2019/424.

- 3(1)(a): See Section 1.1 of the system manual for the product type.
- 3(1)(b): See the title page and preface of the system manual for the trademark and manufacturer's address.
- 3(1)(c): See the title page of the system manual for product model number(s).
- 3(1)(d): See the serial number on the physical system to determine the year of manufacture.
- 3(1)(e-j): **PSU Efficiency and Power Factor Value (Table) (From 80 Plus report)**

PSU Model #: PWS-2K21A-2R Watts: 2200	PSU efficiency				power factor
% of rated load	10 %	20 %	50 %	100 %	50 %
Single output (AC-DC)	92.1 %	94.6%	96.1 %	94.5 %	0.999
Multiple output (AC-DC)	N/A	N/A	N/A	N/A	N/A

### System (EUT) Efficiency in **Idle State** Power (Table)

Representative Configurations	Measured Idle State Power (W)	Calculated Idle Power Allowance (W)
High-end performance configuration	788.9	618.15
Typical Configuration	N/A	N/A
Low-end performance configuration	282.9	192.56

### System (EUT) Efficiency in **Active State** Power (Table)

Representative Configurations	Active state efficiency score (Eff <sub>server</sub> )	Minimum active state efficiency for 2 socket server
High-end performance configuration	16.5	9.5
Typical Configuration	N/A	
Low-end performance configuration	16.5	

3(1)(k): The operating condition class is **A2**.

Operating condition class	Dry bulb temp °C		Humidity range, non-condensing		Max dew point (°C)	Maximum rate of change (°C/hr)
	Allowable range	Recommended range	Allowable range	Recommended range		
A2	10-35	18-27	- 12 °C DP and 8 % RH to 21 °C DP and 80 %	Same as A1	21	5/20

3(1)(l): The idle state power at the higher boundary temperature of the operating conditions class is 919.12 W.

3(1)(m): The active state efficiency and performance is 16.5.

3(1)(n): There are two methods by which a user can securely delete data from this system. The user performing secure data deletion should be an IT professional.

The first is with a Unified Extensible Firmware Interface (UEFI) shell utility. This utility works on X10/X11/H11/H12/M11 motherboard series with onboard SATA/NVMe devices. Any user may access and download this utility through following link:

[https://www.supermicro.com/about/policies/disclaimer.cfm?url=/wftp/utility/Lot9\\_Secure\\_Data\\_Deletion\\_UTILITY/](https://www.supermicro.com/about/policies/disclaimer.cfm?url=/wftp/utility/Lot9_Secure_Data_Deletion_UTILITY/)

Download the shell utility package and extract it to a USB flash drive, then plug the drive into the server for which secure data deletion is necessary. Then turn the system on. Navigate to the BIOS setup menu, then place the server system into the UEFI shell environment. Follow the instructions in the README file to invoke the utility and complete the deletion.

The second method is through the secure data deletion tool provided by the original manufacturer of the hard drive. This should be used in a scenario where the shell utility is not applicable. Each manufacturer should have the tool available on their website. If needed, please look on the hard drive label for the name of the manufacturer and model information.

3(1)(o): List of recommended combinations of blade servers with chassis: N/A.

3(1)(p): List of all current SKUs within this product family: N/A.

3(3)(a): There is no use of cobalt in batteries in this product.

The indicative weight range of neodymium in the HDD is 0.0 if manufactured by Western Digital, and is between 5-25 grams if manufactured by Seagate.

3(3)(b): Please see the disassembly instructions on the next page.

## Illustrated System Disassembly Instructions

*Please note: All the illustrations in the below disassembly instructions are for demonstration only. Components shown here may not match exactly with the components in your system.*

**CAUTION: Always power off the system and unplug the power cord(s) first before disassembling the system!**

---

### 1. Remove Trays

*Type and number of fastenings:* Two (2) latches per tray.

*Tools required:* None.

*Procedure:* Push the release the release levers on each side of the tray.

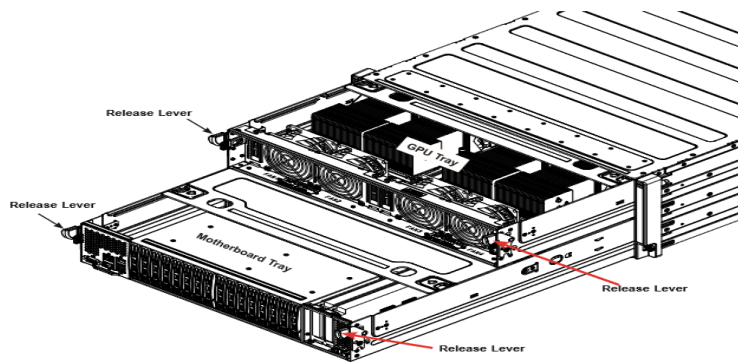

Figure 3-1. Removing the Trays

---

## 2. Power Supply Module

*Type and number of fastenings:* One (1) latch per module.

*Tools required:* None.

*Procedure:* Unplug the power cord from the power supply. Pull the release tab on the back of the power supply module and pull the module straight out.

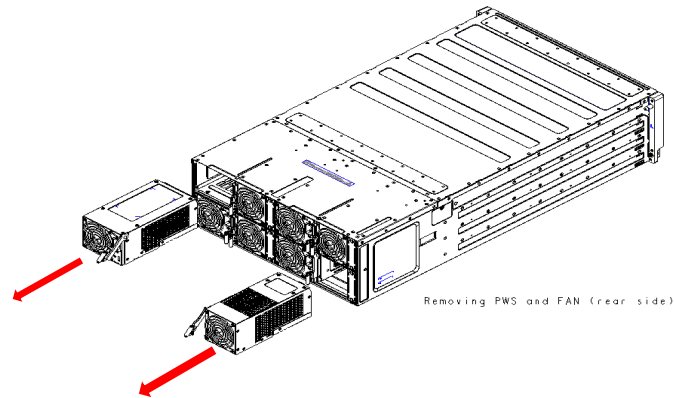

### 3. CPU Heatsink and Processor

*Type and number of fastenings:* Four (4) T20 Torx screws.

*Tools required:* Screwdriver with T20 Torx bit.

*Procedure:* Remove the screws in the sequence of 4, 3, 2, 1. Lift the heatsink module off the socket. Then un-snap the latches in the sequence of A, B, D, D and remove the processor from the socket.

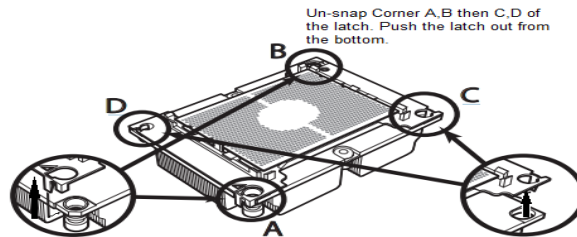
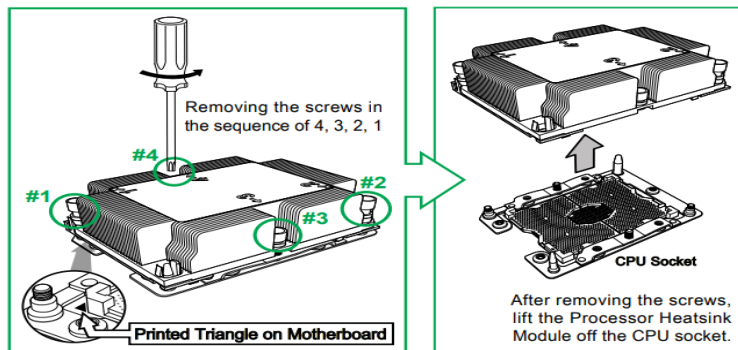

## 4. Memory

*Type and number of fastenings:* Two (2) latches per memory module.

*Tools required:* None.

*Procedure:* Press both release tabs on the ends of the memory module to unlock it. Once the module is loosened, remove it from the memory slot.

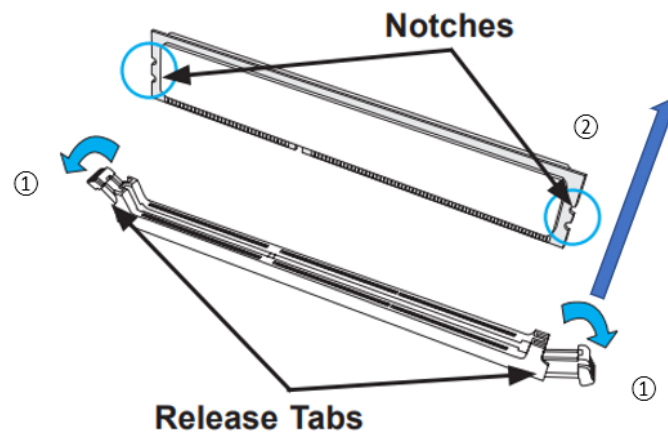

---

## 5. Expansion Card

*Type and number of fastenings:* One (1) Phillips screw.

*Tools required:* Screwdriver with PH2 bit

*Procedure:* Remove the screw and lift the riser card up from the motherboard expansion slot.

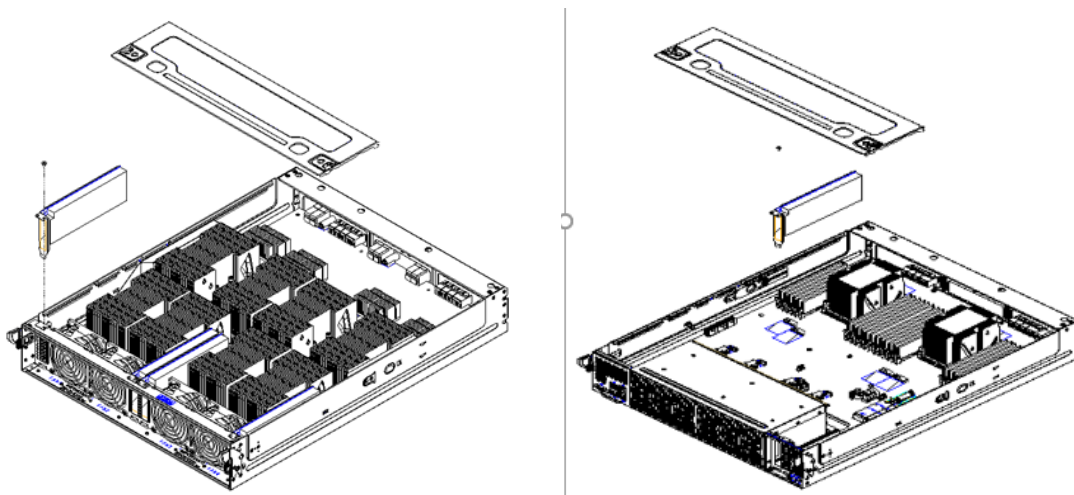

## 6. GPU Fans

*Type and number of fastenings:* Four (4) Phillips screws per fan.

*Tools required:* Screwdriver with PH2 bit.

*Procedure:* Remove the four screws from the rear of the tray and lift the fan.

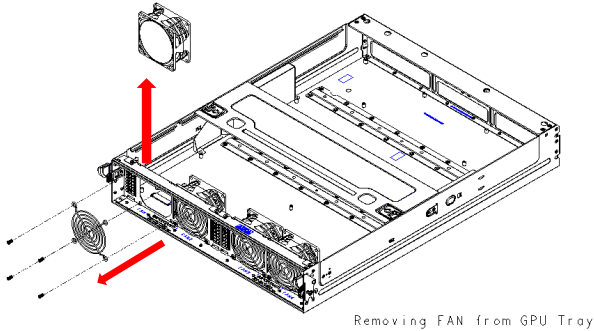

## 7. System Fans

*Type and number of fastenings:* One locking lever

*Tools required:* None

*Procedure:* Lift the locking lever and pull the fan module out of the chassis.

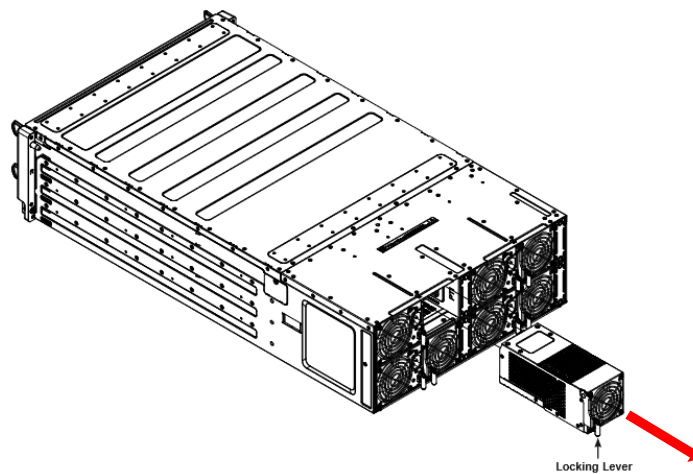

Figure 3-11. Replacing a System Fan

---

## 8. GPU Heatsinks

*Type and number of fastenings:* Four (4) Phillips screws per heatsink

*Tools required:* Screwdriver with PH2 bit.

*Procedure:* Remove the four screws and lift/pry the heatsink.

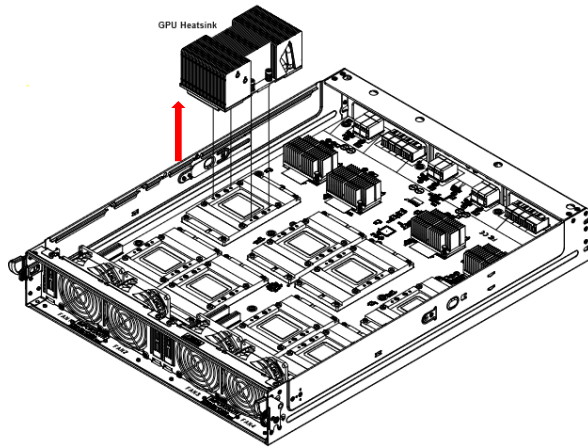

## 9. GPU and GPU Board

*Type and number of fastenings:* Four Phillips screws per GPU; seventeen screws for the board

*Tools required:* Screwdriver with PH2 bit.

*Procedure:* Remove the screws and lift the GPU and the GPU board.

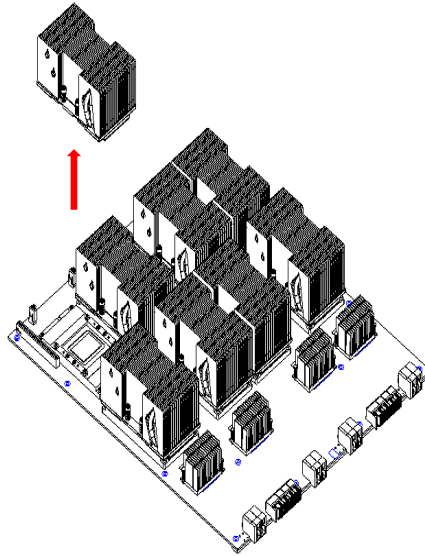

Removing one GPU from GPU board

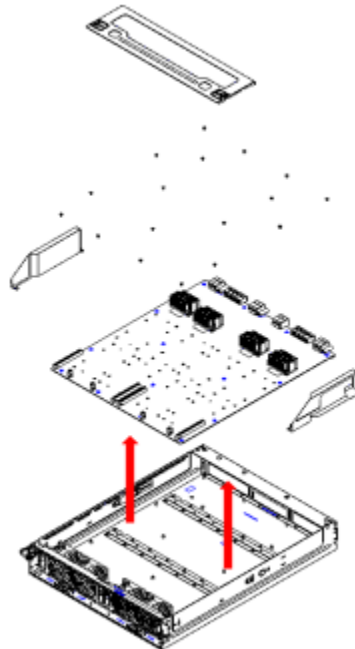

## 10. Motherboard

*Type and number of fastenings:* Eighteen (18) Phillips screws.

*Tools required:* Screwdriver with PH2 bit.

*Procedure:* Remove the screws and lift the motherboard from its base.

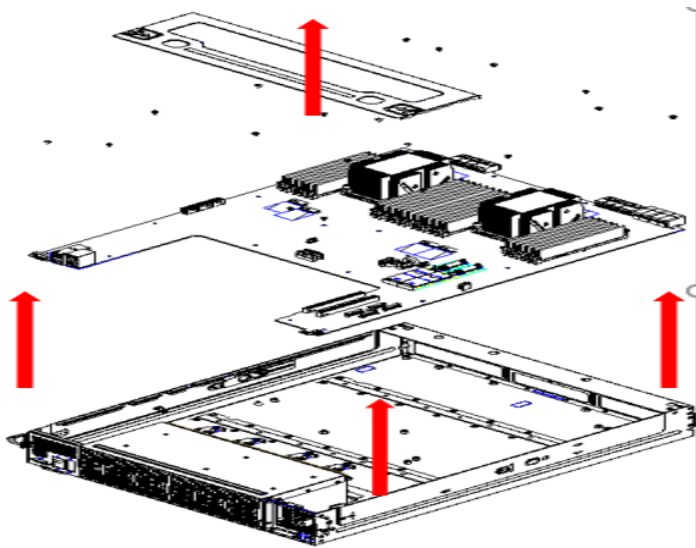

## 11. Front Hot-swap Storage Drives

*Type and number of fastenings:* One locking lever

*Tools required:* None

*Procedure:* Lift the locking lever and pull the drive out of the chassis.

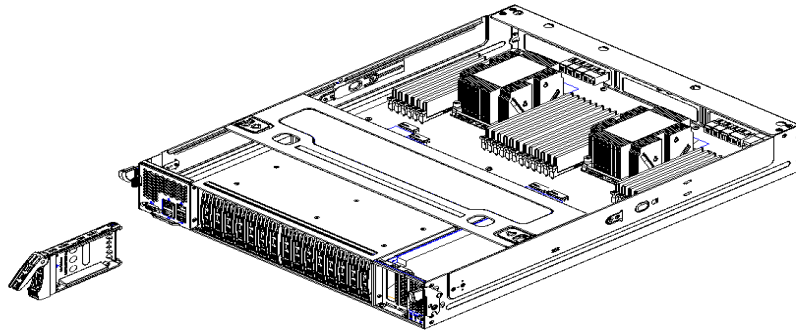

Removing one drive tray from the bottom CPU tray

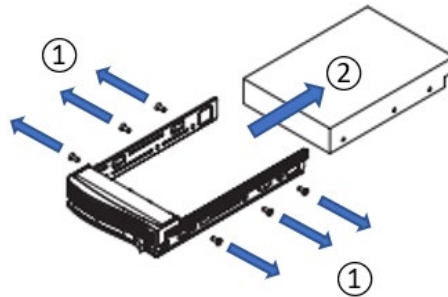

## 12. Backplane

*Type and number of fastenings:* Six Phillips screws

*Tools required:* Screwdriver with PH2 bit.

*Procedure:* Remove the six screws and pull the fan module out.

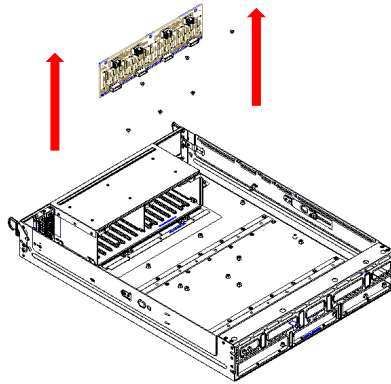

Removing the drive tray backplane from the CPU tray

---

### 13. Mid-plane

Type and number of fastenings: Twenty-one Phillips screws

Tools required: Screwdriver with PH2 bit.

Procedure: Remove the screws, pull the small center assembly out, then pull the mid-pland board from the storage drive assembly.

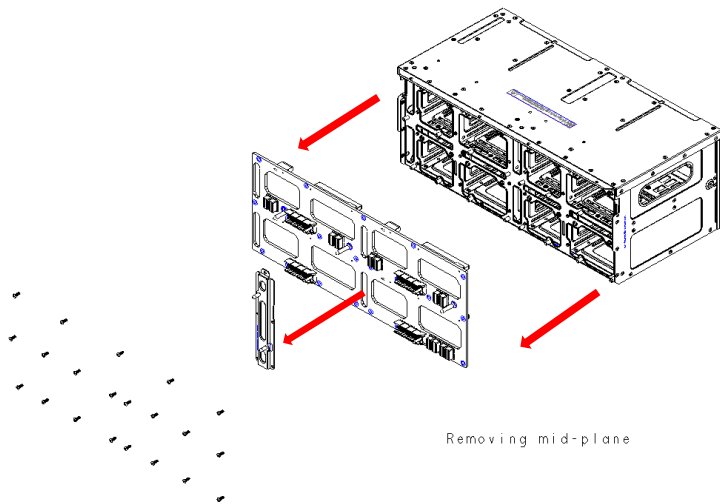

---

### 14. Battery

Type and number of fastenings: One (1) latch.

Tools required: None.

Procedure: Push aside the small clamp that covers the edge of the battery. When the battery is released, lift it out of the holder.

