

Information for Lot 9 of ErP (Ecodesign)

This addendum addresses European Union (EU) Ecodesign requirements for servers and storage products. All data and ratings within this addendum are in reference only to the Supermicro product(s) in the manual. The below information conforms to requirements laid down in Annex II of the Commission Regulation 2019/424.

- 3(1)(a): See Section 1.1 of the system manual for the product type.
- 3(1)(b): See the title page and preface of the system manual for the trademark and manufacturer's address.
- 3(1)(c): See the title page of the system manual for product model number(s).
- 3(1)(d): See the serial number on the physical system to determine the year of manufacture.
- 3(1)(e-j): **PSU Efficiency and Power Factor Value (Table) (From 80 Plus report)**

PSU Model #: PWS-6K61G-2R Watts: 6600W	PSU Efficiency				Power Factor
	10 %	20 %	50 %	100 %	
% of Rated Load	90.88%	94.68%	96.27%	95.33%	0.9920
Single Output (AC-DC)	90.88%	94.68%	96.27%	95.33%	0.9920

System (EUT) Efficiency in **Idle State** Power (Table)

Representative Configurations	Measured Idle State Power (W)	Calculated Idle Power Allowance (W)
High-End Performance Configuration	1409	1103.08
Typical Configuration	N/A	N/A
Low-End Performance Configuration	1666.3	770.35

System (EUT) Efficiency in **Active State** Power (Table)

Representative Configurations	Active State Efficiency Score (Effserver)	Minimum Active State Efficiency for 2-Socket Server
High-End Performance Configuration	60.6	9.5
Typical Configuration	N/A	
Low-End Performance Configuration	42	

3(1)(k): The operating condition class is **A2**.

Operating condition class	Dry bulb temp °C		Humidity range, non-condensing		Max dew point (°C)	Maximum rate of change (°C/hr)
	Allowable range	Recommended range	Allowable range	Recommended range		
A1	15- 32	18-27	- 12 °C Dew Point (DP) and 8 % relative humidity (RH) to 17 °C DP and 80 % RH	- 9 °C DP to 15 °C DP and 60 % RH	17	5/20
A2	10-35	18-27	- 12 °C DP and 8 % RH to 21 °C DP and 80 % RH	Same as A1	21	5/20
A3	5-40	18-27	- 12 °C DP and 8 % RH to 24 °C DP and 85 % RH	Same as A1	24	5/20
A4	5-45	18-27	- 12 °C DP and 8 % RH to 24 °C DP and 90 % RH	Same as A1	24	5/20

3(1)(l): The idle state power at the higher boundary temperature of the operating conditions class is 1662.62 W.

3(1)(m): The active state efficiency and performance is 60.6.

3(1)(n): The user performing secure data deletion should be an IT professional.

The method is through the secure data deletion tool provided by the original manufacturer of the hard drive. Each manufacturer should have the tool available on their website. If needed, please look on the hard drive label for the name of the manufacturer and model information.

3(1)(o): List of recommended combinations of blade servers with chassis: N/A.

3(1)(p): List of all current SKUs within this product family: SYS-422GA-NBRT-LCC.

3(3)(a): There is no use of cobalt in batteries in this product.

The indicative weight range of neodymium in the HDD is 0.0 if manufactured by Western Digital, and is between 5-25 grams if manufactured by Seagate.

3(3)(b): Please see the disassembly instructions on the next page.

Illustrated System Disassembly Instructions

Please note: All the illustrations in the below disassembly instructions are for demonstration only. Components shown here may not match exactly with the components in your system.

CAUTION: Always power off the system and unplug the power cord(s) first before disassembling the system!

1. Chassis Cover

Type and number of fastenings: Four (4) Phillips screws.

Tools required: Screwdriver with PH2 bit.

Procedure:

1. Remove the four screws securing the cover to the chassis.
2. Lift the top cover off the chassis.

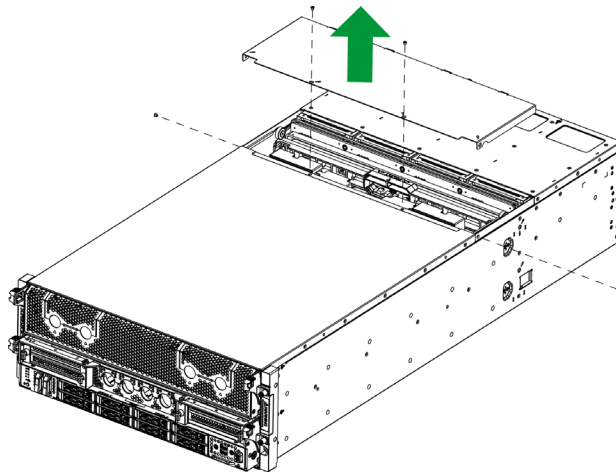

2. CPU Tray

Type and number of fastenings: Two (2) Phillips screws, and two (2) latches.

Tools required: Screwdriver with PH2 bit.

Procedure:

1. At the front of the server, remove the two screws securing the clips at the left and right sides of the CPU tray.

2. Unlatch the two clips at both sides of the CPU tray. The latches of the tray will open downward.
3. Applying pressure evenly, carefully pull the tray out of the chassis.

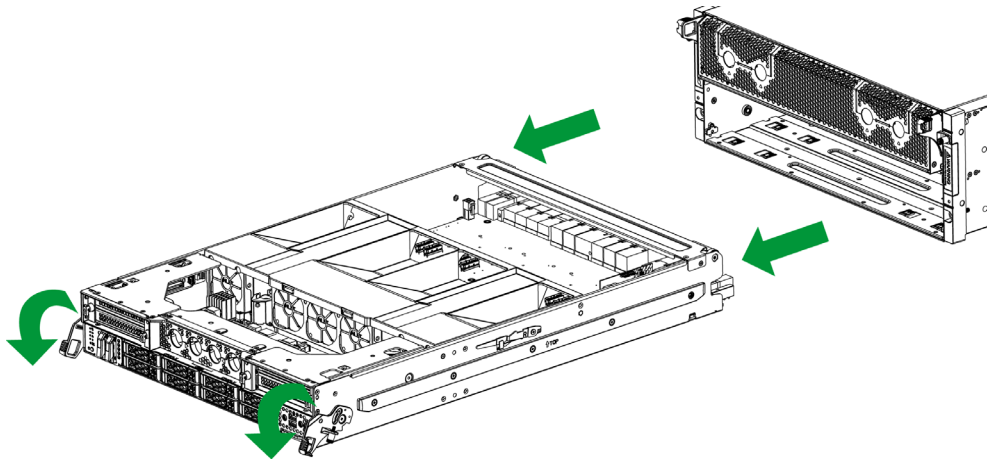

3. GPU Tray

Type and number of fastenings: Two (2) Phillips screws, and two (2) latches.

Tools required: Screwdriver with PH2 bit.

Procedure:

1. At the front of the server, remove the two screws securing the clips at the left and right sides of the GPU tray.
2. Unlatch the two clips at both sides of the GPU tray. The latches of the tray will open downward.
3. Applying pressure evenly, carefully pull the tray out of the chassis.

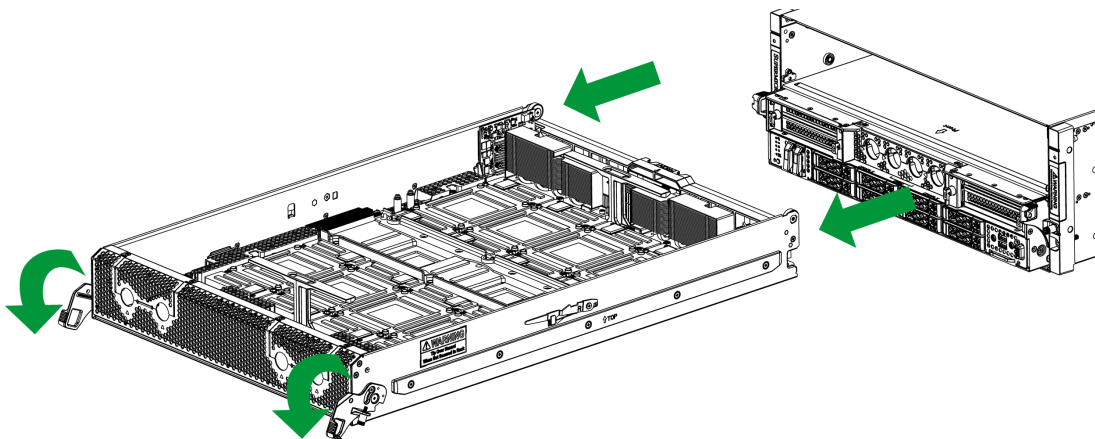

4. I/O Tray

Type and number of fastenings: Two (2) Phillips screws, and two (2) latches.

Tools required: Screwdriver with PH2 bit.

Procedure:

1. At the rear of the server, remove the two screws securing the clips at the left and right sides of the I/O tray.
2. Unlatch the two clips at both sides of the I/O tray. The latches of the tray will open upward.
3. Applying pressure evenly, carefully pull the tray out of the chassis.

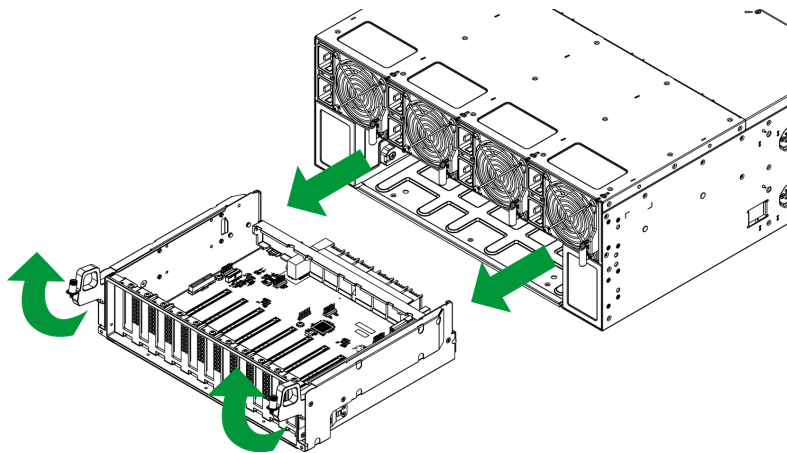

5. Memory

Type and number of fastenings: Two (2) latches per memory module.

Tools required: None.

Procedure: Press both release tabs on the ends of the memory module to unlock it. Once the module is loosened, remove it from the memory slot.

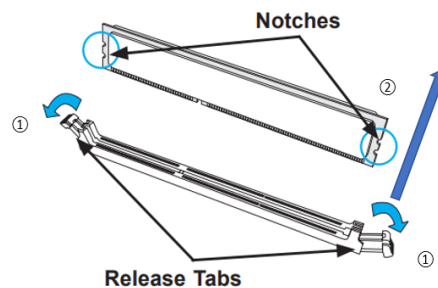

7. Battery

Type and number of fastenings: One (1) latch.

Tools required: None.

Procedure: Push aside the small clamp that covers the edge of the battery. When the battery is released, lift it out of the holder.

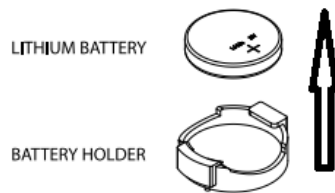

8. M.2 Drive

Type and number of fastenings: One (1) Phillips screw.

Tools required: Screwdriver with PH2 bit.

Procedure:

1. Locate and lift the M.2 tray latch.
2. Unplug the M.2 tray.
3. Unscrew the M.2 drive from the tray.

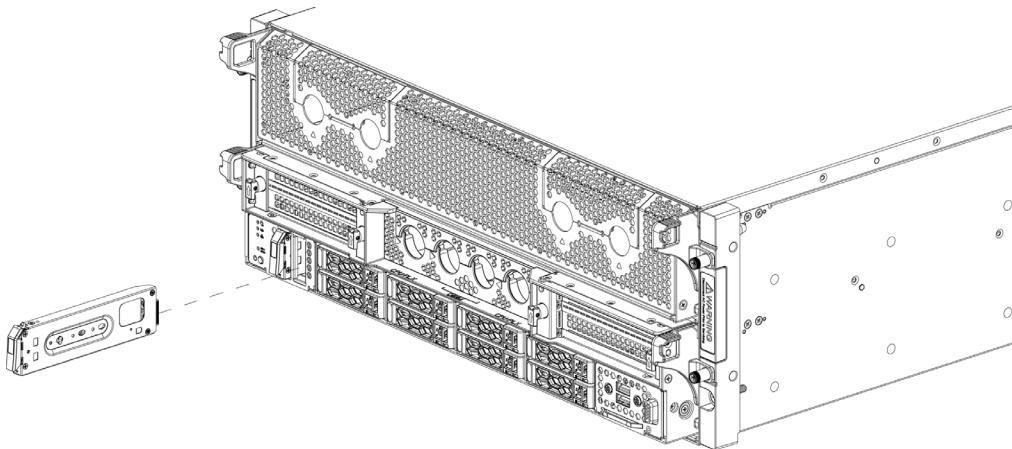

9. 2.5" Drive

Type and number of fastenings: One (1) latch.

Tools required: Flat-head screwdriver (optional).

Procedure:

1. Remove the drive carrier from the chassis. Push the release button on the drive carrier. This releases and extends the drive carrier handle.
2. If the button does not release the handle, it may be locked. Using a flat-head screwdriver, rotate the screw counterclockwise 45 degrees to unlock the handle.
3. Use the handle to pull the carrier out of the chassis.
4. Remove the drive from the drive carrier.

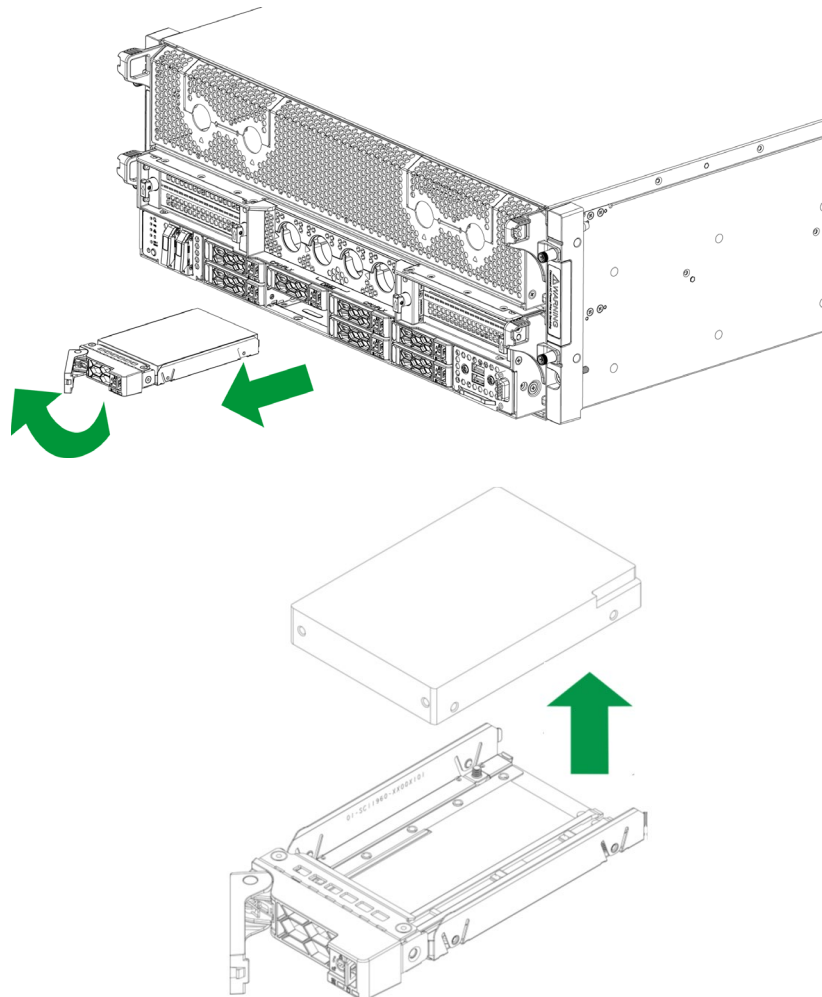

10. Fan

Type and number of fastenings: None.

Tools required: None.

Procedure: Disconnect the fan cable from the motherboard and lift it away from the motherboard.

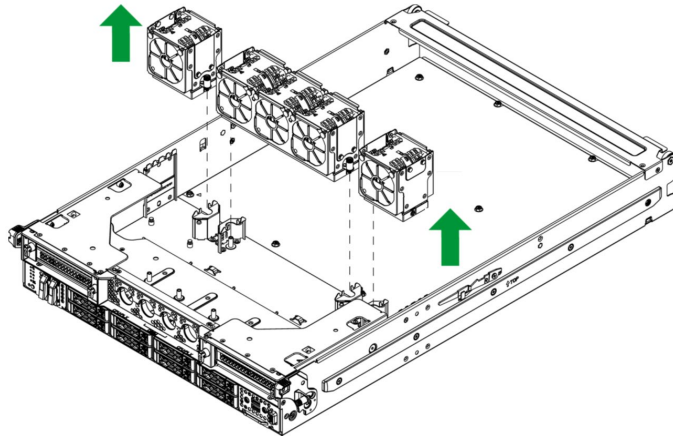

11. Air Shroud

Type and number of fastenings: None.

Tools required: None.

Procedure: Lift the air shroud away from the motherboard.

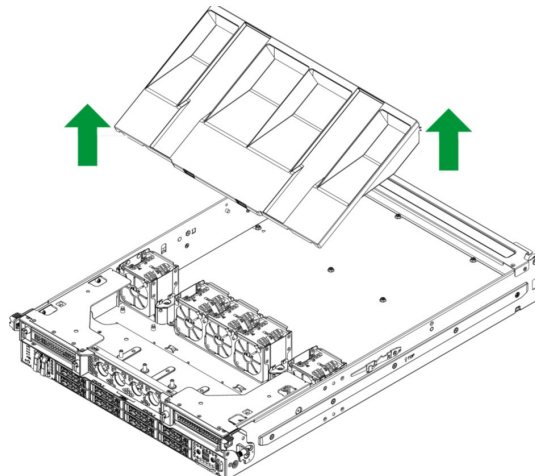

12. CPU Drawer Front Riser Card

Type and number of fastenings: One (1) Phillips screw per riser card.

Tools required: Screwdriver with PH2 bit.

Procedure:

1. Lift the riser card brackets away from the CPU tray.
2. Remove the screws to separate the riser cards from riser card brackets.

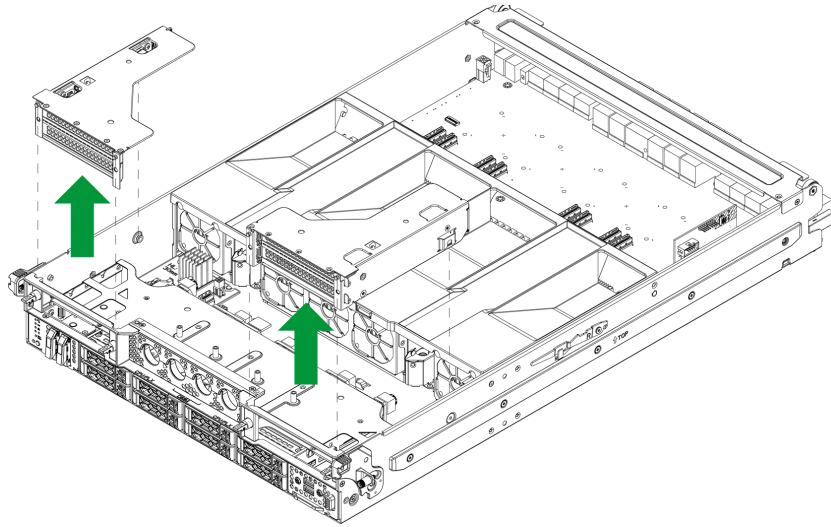

13. Power Supply Module

Type and number of fastenings: One (1) latch per module.

Tools required: None.

Procedure: Unplug the power cord from the power supply. Push the release tab on the back of the power supply module to the side and pull the module straight out.

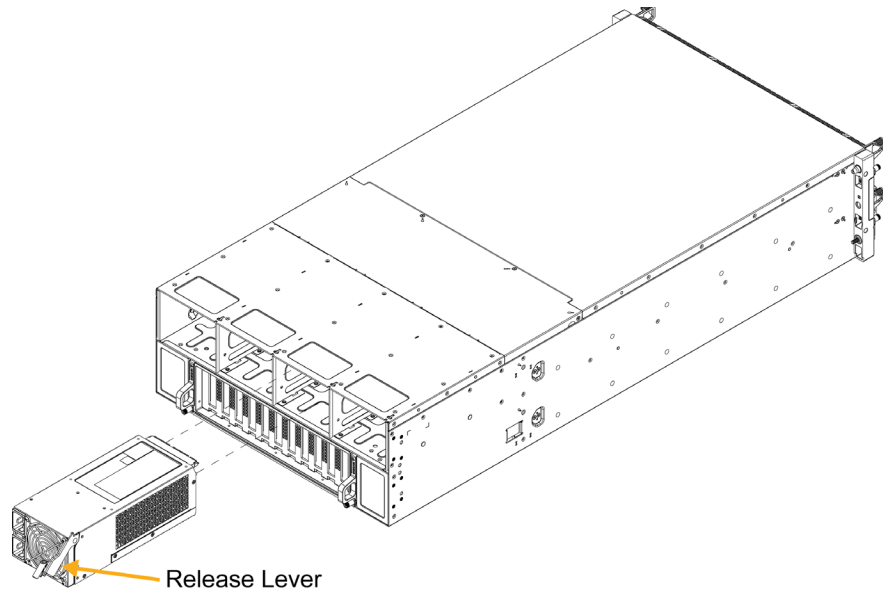

Release Lever