

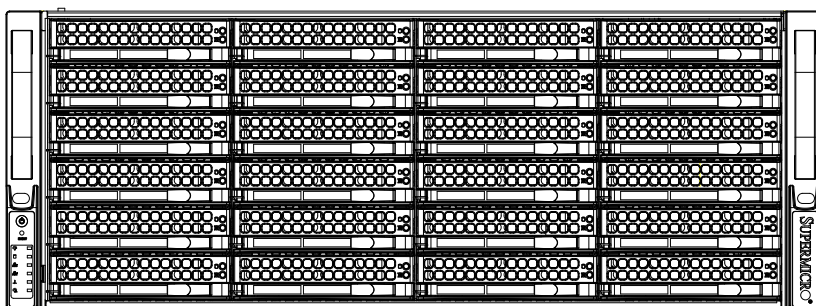

# SUPER STORAGE SYSTEM

## 6048R-E1CR36L



# USER'S MANUAL

1.0a

The information in this User's Manual has been carefully reviewed and is believed to be accurate. The vendor assumes no responsibility for any inaccuracies that may be contained in this document, makes no commitment to update or to keep current the information in this manual, or to notify any person or organization of the updates. **Please Note: For the most up-to-date version of this manual, please see our web site at [www.supermicro.com](http://www.supermicro.com).**

Super Micro Computer, Inc. ("Supermicro") reserves the right to make changes to the product described in this manual at any time and without notice. This product, including software and documentation, is the property of Supermicro and/or its licensors, and is supplied only under a license. Any use or reproduction of this product is not allowed, except as expressly permitted by the terms of said license.

IN NO EVENT WILL SUPERMICRO BE LIABLE FOR DIRECT, INDIRECT, SPECIAL, INCIDENTAL, SPECULATIVE OR CONSEQUENTIAL DAMAGES ARISING FROM THE USE OR INABILITY TO USE THIS PRODUCT OR DOCUMENTATION, EVEN IF ADVISED OF THE POSSIBILITY OF SUCH DAMAGES. IN PARTICULAR, SUPERMICRO SHALL NOT HAVE LIABILITY FOR ANY HARDWARE, SOFTWARE, OR DATA STORED OR USED WITH THE PRODUCT, INCLUDING THE COSTS OF REPAIRING, REPLACING, INTEGRATING, INSTALLING OR RECOVERING SUCH HARDWARE, SOFTWARE, OR DATA.

Any disputes arising between manufacturer and customer shall be governed by the laws of Santa Clara County in the State of California, USA. The State of California, County of Santa Clara shall be the exclusive venue for the resolution of any such disputes. Super Micro's total liability for all claims will not exceed the price paid for the hardware product.

FCC Statement: This equipment has been tested and found to comply with the limits for a Class A digital device pursuant to Part 15 of the FCC Rules. These limits are designed to provide reasonable protection against harmful interference when the equipment is operated in a commercial environment. This equipment generates, uses, and can radiate radio frequency energy and, if not installed and used in accordance with the manufacturer's instruction manual, may cause harmful interference with radio communications. Operation of this equipment in a residential area is likely to cause harmful interference, in which case you will be required to correct the interference at your own expense.

California Best Management Practices Regulations for Perchlorate Materials: This Perchlorate warning applies only to products containing CR (Manganese Dioxide) Lithium coin cells. "Perchlorate Material-special handling may apply. See [www.dtsc.ca.gov/hazardouswaste/perchlorate](http://www.dtsc.ca.gov/hazardouswaste/perchlorate)"

**WARNING: Handling of lead solder materials used in this product may expose you to lead, a chemical known to the State of California to cause birth defects and other reproductive harm.**

Manual Revision 1.0a  
Release Date: May 18, 2016

Unless you request and receive written permission from Super Micro Computer, Inc., you may not copy any part of this document.

Information in this document is subject to change without notice. Other products and companies referred to herein are trademarks or registered trademarks of their respective companies or mark holders.

Copyright © 2016 by Super Micro Computer, Inc.  
All rights reserved.  
**Printed in the United States of America**

---

---

## Preface

### About This Manual

This manual is written for professional system integrators and PC technicians. It provides information for the installation and use of the 6048R-E1CR36L. Installation and maintenance should be performed by experienced technicians only.

The 6048R-E1CR36L is a high-end storage system based on the SC847BE1C-R1K28LPB 4U rackmount chassis and the X10DRH-iT dual processor serverboard.

### Manual Organization

#### Chapter 1: Introduction

The first chapter provides a checklist of the main components included with the system and describes the main features of the X10DRH-iT serverboard and the SC847BE1C-R1K28LPB chassis.

#### Chapter 2: Server Installation

This chapter describes the steps necessary to install the 6048R-E1CR36L into a rack and check out the server configuration prior to powering up the system. If your server was ordered without processor and memory components, this chapter will refer you to the appropriate sections of the manual for their installation.

#### Chapter 3: System Interface

Refer here for details on the system interface, which includes the functions and information provided by the control panel on the chassis as well as other LEDs located throughout the system.

#### Chapter 4: Standardized Safety Warnings

You should thoroughly familiarize yourself with this chapter for a general overview of safety precautions that should be followed when installing and servicing the 6048R-E1CR36L.

**Chapter 5: Advanced Serverboard Setup**

Chapter 5 provides detailed information on the X10DRH-iT serverboard, including the locations and functions of connections, headers and jumpers. Refer to this chapter when adding or removing processors or main memory and when reconfiguring the serverboard.

**Chapter 6: Advanced Chassis Setup**

Refer to Chapter 6 for detailed information on the SC847BE1C-R1K28LPB chassis. You should follow the procedures given in this chapter when installing, removing or reconfiguring SAS/SATA or peripheral drives and when replacing system power supply units and cooling fans.

**Chapter 7: BIOS**

The BIOS chapter includes an introduction to BIOS and provides detailed information on running the CMOS Setup Utility.

**Appendix A: BIOS Error Beep Codes****Appendix B: System Specifications****Notes**

## Table of Contents

### Chapter 1 Introduction

1-1	Overview .....	1-1
1-2	Serverboard Features .....	1-2
	Processors .....	1-2
	Memory .....	1-2
	Main Storage Controller .....	1-2
	Serial ATA .....	1-2
	PCI Expansion Slots .....	1-2
	Rear I/O Ports .....	1-2
	Onboard Graphics .....	1-3
1-3	Server Chassis Features .....	1-3
	System Power .....	1-3
	Hard Drive Subsystem .....	1-3
	Front Control Panel .....	1-3
	Cooling System .....	1-3
1-4	Contacting Supermicro .....	1-5

### Chapter 2 Server Installation

2-1	Overview .....	2-1
2-2	Unpacking the System .....	2-1
2-3	Preparing for Setup .....	2-1
	Choosing a Setup Location .....	2-1
2-4	Warnings and Precautions .....	2-2
	Rack Precautions .....	2-2
	Server Precautions .....	2-2
	Rack Mounting Considerations .....	2-3
	Ambient Operating Temperature .....	2-3
	Reduced Airflow .....	2-3
	Mechanical Loading .....	2-3
	Circuit Overloading .....	2-3
	Reliable Ground .....	2-3
2-5	Rack Mounting Instructions .....	2-4
	Identifying the Sections of the Rack Rails .....	2-4
	Installing the Inner Rails on the Chassis .....	2-4
	Locking Tabs .....	2-5
	Releasing the Inner Rail .....	2-5
	Installing The Inner Rails on the Chassis .....	2-6
	Installing the Outer Rails on the Rack .....	2-7

### Chapter 3 System Interface

3-1	Overview .....	3-1
3-2	Control Panel Buttons .....	3-1
	Reset .....	3-1
	Power .....	3-1
3-3	Control Panel LEDs .....	3-2
	Power Fail .....	3-2
	Information LED .....	3-2
	NIC1 .....	3-3
	NIC2 .....	3-3
	HDD .....	3-3
	Power .....	3-3
3-4	Drive Carrier LEDs .....	3-4

### Chapter 4 Standardized Warning Statements for AC Systems

4-1	About Standardized Warning Statements .....	4-1
	Warning Definition .....	4-1
	Installation Instructions .....	4-4
	Circuit Breaker .....	4-5
	Power Disconnection Warning .....	4-6
	Equipment Installation .....	4-8
	Restricted Area .....	4-9
	Battery Handling .....	4-10
	Redundant Power Supplies .....	4-12
	Backplane Voltage .....	4-13
	Comply with Local and National Electrical Codes .....	4-14
	Product Disposal .....	4-15
	Hot Swap Fan Warning .....	4-16
	Power Cable and AC Adapter .....	4-18

### Chapter 5 Advanced Serverboard Setup

5-1	Handling the Serverboard .....	5-1
	Precautions .....	5-1
5-2	Connecting Cables .....	5-2
	Connecting Data Cables .....	5-2
	Connecting Power Cables .....	5-2
	Connecting the Control Panel .....	5-2
5-3	Rear I/O Ports .....	5-3
5-4	Installing the Processor and Heatsink .....	5-4
	Installing an LGA2011 Processor .....	5-4
	Installing a Passive CPU Heatsink .....	5-7

Removing the Heatsink .....	5-7
5-5 Installing Memory .....	5-8
Memory Support .....	5-8
DIMM Installation .....	5-8
5-6 Adding PCI Expansion Cards .....	5-11
5-7 Serverboard Details .....	5-12
X10DRH-iT Quick Reference .....	5-13
5-8 Connector Definitions .....	5-14
5-9 Jumper Settings .....	5-21
5-10 Onboard Indicators .....	5-24
5-11 SATA Ports .....	5-25
5-12 Installing Software .....	5-26
SuperDoctor® 5 .....	5-27
5-13 Onboard Battery .....	5-28

### **Chapter 6 Advanced Chassis Setup**

6-1 Static-Sensitive Devices .....	6-1
Precautions .....	6-1
6-2 Control Panel .....	6-2
6-3 Removing the Chassis Cover .....	6-3
6-4 System Fans .....	6-4
System Fan Failure .....	6-4
Replacing System Fans .....	6-4
6-5 Drive Bay Installation/Removal .....	6-5
Accessing the Drive Bays .....	6-5
Hard Drive Installation .....	6-6
Hard Drive Backplane .....	6-7
Removing the Air Shroud .....	6-8
6-6 Installing Optional Fixed Hard Drives .....	6-9
6-7 Power Supply .....	6-10
Power Supply Failure .....	6-10
DC Power .....	6-11
6-8 Attaching a JBOD Expansion Chassis .....	6-11

### **Chapter 7 BIOS**

7-1 Introduction .....	7-1
Starting BIOS Setup Utility .....	7-1
How To Change the Configuration Data .....	7-1
How to Start the Setup Utility .....	7-2
7-2 Main Setup .....	7-2
7-3 Advanced Setup Configurations .....	7-4

7-4 Event Logs .....	7-40
7-5 IPMI .....	7-42
7-6 Security Settings .....	7-44
7-7 Boot Settings .....	7-45
7-8 Save & Exit .....	7-46

### **Appendix A BIOS Error Beep Codes**

### **Appendix B System Specifications**

# Notes

# Chapter 1

## Introduction

### 1-1 Overview

The SuperStorageSystem 6048R-E1CR36L is comprised of two main subsystems: the SC847BE1C-R1K28LPB 4U chassis and the X10DRH-iT dual processor serverboard. Please refer to our website for information on operating systems that have been certified for use with the system ([www.supermicro.com](http://www.supermicro.com)).

In addition to the serverboard and chassis, various hardware components have been included with the 6048R-E1CR36L, as listed below:

- Two passive CPU heatsinks (SNK-P0048PS)
- Seven 8-cm system fans (FAN-0126L4)
- One air shroud (MCP-310-49004-0N)
- SAS3/SATA3 Storage
  - Two SAS3 backplanes (BPN-SAS3-826EL1, BPN-SAS3-847EL1)
  - Thirty-six drive carriers (MCP-220-00075-OB)
- 12 Gb/s IT mode disk controller (AOC-S3008L-L8E)
- JBOD Expansion Port (AOM-SAS3-8I8E-LP)
- One rackmount kit (MCP-290-00057-0N)

**Note:** For your system to work properly, please follow the links below to download all necessary drivers/utilities and the user's manual for your server.

- Supermicro product manuals: <http://www.supermicro.com/support/manuals/>
- Product drivers and utilities: <ftp://ftp.supermicro.com>
- Product safety info: [http://www.supermicro.com/about/policies/safety\\_information.cfm](http://www.supermicro.com/about/policies/safety_information.cfm)
- If you have any questions, please contact our support team at: [support@supermicro.com](mailto:support@supermicro.com)

## 1-2 Serverboard Features

The SuperStorageSystem 6048R-E1CR36L is built around the X10DRH-iT, a dual processor serverboard based on the Intel C612 chipset. Below are the main features of the X10DRH-iT. (See Figure 1-1 for a block diagram of the chipset.)

### Processors

The X10DRH-iT supports single or dual Intel® Xeon E5-2600 (v3/v4) Series processors. Please refer to the serverboard description pages on our website for a complete listing of supported processors ([www.supermicro.com](http://www.supermicro.com)).

### Memory

The X10DRH-iT has 16 DIMM slots that can support up to 2 TB of ECC LRDIMM (Load Reduced DIMM) or 1 TB of ECC RDIMM (Registered DIMM) DDR4-2400/2133/1866/1600 memory. See Chapter 5 for details.

### Main Storage Controller

An LSI 3008 controller card is included in the system to support up to 240 SATA 3.0/SAS 3.0 hard drives. The SATA/SAS drives are hot-swappable units.

### Serial ATA

A SATA controller is integrated into the chipset to provide 10 SATA 3.0 (6/Gbps) ports (I-SATA0-5 supported by the Intel PCH and a vertical. 4-port S-SATA connection supported by the Intel SCU), which are RAID 0, 1 and 10 supported. The SATA drives are hot-swappable units. (RAID 5 supported with Windows OS only.)

### PCI Expansion Slots

The X10DRH-iT has six PCI-Express 3.0 x8 slots (CPU1 Slots 1-3 and CPU2 Slots 5-7) and one PCI-Express 3.0 x16 slot (CPU2 Slot4).

### Rear I/O Ports

The I/O ports include one COM port, a VGA port, four USB (two USB 3.0 and two USB 2.0), two 10G (TLAN) Ethernet ports, a dedicated IPMI LAN port and dual JBOD expansion ports. A UID (Unit Identifier) button and LED are also located beside the VGA port.

## Onboard Graphics

Graphics are provided by an onboard ASpeed AST 2400 BMC, which supports IPMI.

## 1-3 Server Chassis Features

The SC847BE1C-R1K28LPB is a 4U form factor chassis designed to be used in a storage configuration. The following is a general outline of the main features of the chassis.

### System Power

The SC847BE1C-R1K28LPB features a redundant, hot-plug (two separate power modules) 1280W high-efficiency power supply with I<sup>2</sup>C. This power redundancy feature allows you to replace a failed power supply without shutting down the system.

### Hard Drive Subsystem

The SC847BE1C-R1K28LPB chassis was designed to support 36 SATA/SAS hard drives (24 on the front of the chassis and 12 located on the rear of the chassis), which are hot-swappable units.

### Front Control Panel

The control panel on the front of the chassis provides you with system monitoring and control. LEDs indicate system power, HDD activity, network activity, system overheat/fan fail and power supply failure. A main power button and a system reset button are also included. In addition, two USB ports and a COM port have been incorporated into the front of the chassis for convenient access.

### Cooling System

The SC847BE1C-R1K28LPB chassis includes seven 8-cm hot-plug system cooling fans located in the middle section of the chassis. An air shroud channels the airflow from the system fans to efficiently cool the processors and memory. Each power supply module also includes a cooling fan.

**Figure 1-1. Intel C612 Chipset:  
System Block Diagram**

Note: This is a general block diagram. Please see Chapter 5 for details.

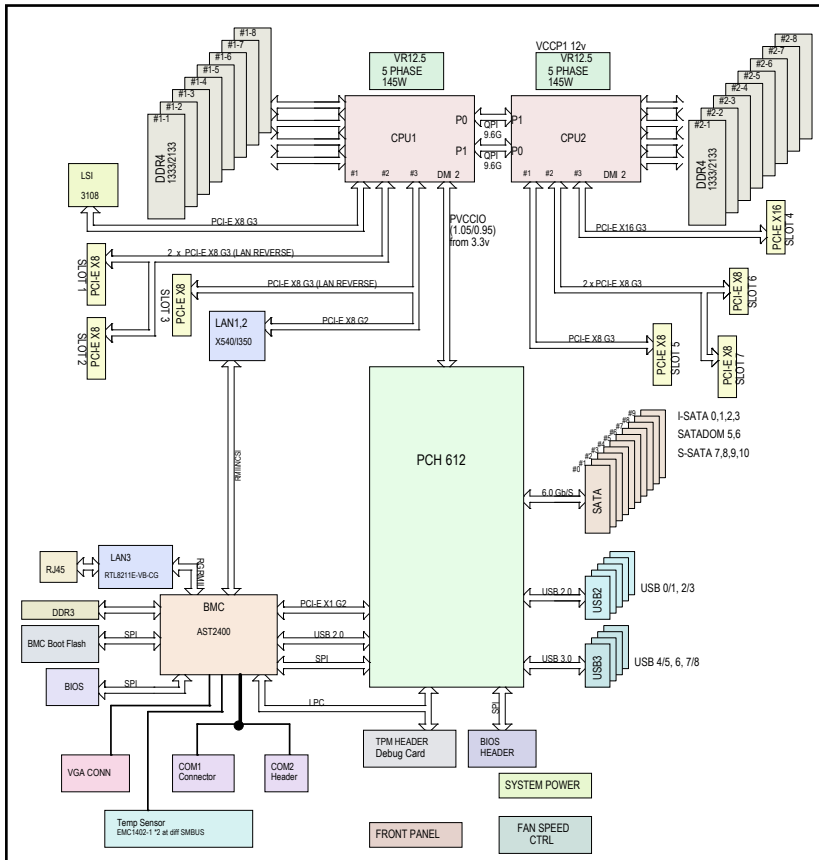

## 1-4 Contacting Supermicro

### Headquarters

Address: Super Micro Computer, Inc.  
980 Rock Ave.  
San Jose, CA 95131 U.S.A.  
Tel: +1 (408) 503-8000  
Fax: +1 (408) 503-8008  
Email: marketing@supermicro.com (General Information)  
support@supermicro.com (Technical Support)  
Website: [www.supermicro.com](http://www.supermicro.com)

### Europe

Address: Super Micro Computer B.V.  
Het Sterrenbeeld 28, 5215 ML  
's-Hertogenbosch, The Netherlands  
Tel: +31 (0) 73-6400390  
Fax: +31 (0) 73-6416525  
Email: sales@supermicro.nl (General Information)  
support@supermicro.nl (Technical Support)  
rma@supermicro.nl (Customer Support)  
Website: [www.supermicro.nl](http://www.supermicro.nl)

### Asia-Pacific

Address: Super Micro Computer, Inc.  
3F, No. 150, Jian 1st Rd.  
Zhonghe Dist., New Taipei City 235  
Taiwan (R.O.C)  
Tel: +886-(2) 8226-3990  
Fax: +886-(2) 8226-3992  
Email: support@supermicro.com.tw  
Website: [www.supermicro.com.tw](http://www.supermicro.com.tw)

# Notes

## Chapter 2

# Server Installation

### 2-1 Overview

This chapter provides a quick setup checklist to get the 6048R-E1CR36L up and running. Following these steps in the order given should enable you to have the system operational within a minimum amount of time. This quick setup assumes that your system has come to you with the processors and memory preinstalled. If your system is not already fully integrated with a serverboard, processors, system memory etc., please turn to the chapter or section noted in each step for details on installing specific components.

### 2-2 Unpacking the System

You should inspect the box the 6048R-E1CR36L was shipped in and note if it was damaged in any way. If the server itself shows damage you should file a damage claim with the carrier who delivered it.

Decide on a suitable location for the rack unit that will hold the 6048R-E1CR36L. It should be situated in a clean, dust-free area that is well ventilated. Avoid areas where heat, electrical noise and electromagnetic fields are generated. You will also need it placed near a grounded power outlet. Read the Rack and Server Precautions in the next section.

### 2-3 Preparing for Setup

The box the 6048R-E1CR36L was shipped in should include two sets of rail assemblies, two rail mounting brackets and the mounting screws you will need to install the system into the rack. Follow the steps in the order given to complete the installation process in a minimum amount of time. Please read this section in its entirety before you begin the installation procedure outlined in the sections that follow.

#### Choosing a Setup Location

- Leave enough clearance in front of the rack to enable you to open the front door completely (~25 inches) and approximately 30 inches of clearance in the back of the rack to allow for sufficient airflow and ease in servicing.

- This product is for installation only in a Restricted Access Location (dedicated equipment rooms, service closets and the like).
- This product is not suitable for use with visual display work place devices according to §2 of the the German Ordinance for Work with Visual Display Units.

## 2-4 Warnings and Precautions

### Rack Precautions

- Ensure that the leveling jacks on the bottom of the rack are fully extended to the floor with the full weight of the rack resting on them.
- In single rack installation, stabilizers should be attached to the rack. In multiple rack installations, the racks should be coupled together.
- Always make sure the rack is stable before extending a component from the rack.
- You should extend only one component at a time - extending two or more simultaneously may cause the rack to become unstable.

### Server Precautions

- Review the electrical and general safety precautions in Chapter 4.
- Determine the placement of each component in the rack *before* you install the rails.
- Install the heaviest server components on the bottom of the rack first, and then work up.
- Use a regulating uninterruptible power supply (UPS) to protect the server from power surges, voltage spikes and to keep your system operating in case of a power failure.
- Allow any hot plug drives and power supply modules to cool before touching them.
- Always keep the rack's front door and all panels and components on the servers closed when not servicing to maintain proper cooling.

## Rack Mounting Considerations

### *Ambient Operating Temperature*

If installed in a closed or multi-unit rack assembly, the ambient operating temperature of the rack environment may be greater than the room's ambient temperature. Therefore, consideration should be given to installing the equipment in an environment compatible with the manufacturer's maximum rated ambient temperature (TMRA).

### *Reduced Airflow*

Equipment should be mounted into a rack so that the amount of airflow required for safe operation is not compromised.

### *Mechanical Loading*

Equipment should be mounted into a rack so that a hazardous condition does not arise due to uneven mechanical loading.

### *Circuit Overloading*

Consideration should be given to the connection of the equipment to the power supply circuitry and the effect that any possible overloading of circuits might have on overcurrent protection and power supply wiring. Appropriate consideration of equipment nameplate ratings should be used when addressing this concern.

### *Reliable Ground*

A reliable ground must be maintained at all times. To ensure this, the rack itself should be grounded. Particular attention should be given to power supply connections other than the direct connections to the branch circuit (i.e. the use of power strips, etc.).



**Warning!** To prevent bodily injury when mounting or servicing this unit in a rack, you must take special precautions to ensure that the system remains stable. The following guidelines are provided to ensure your safety:

- This unit should be mounted at the bottom of the rack if it is the only unit in the rack.
- When mounting this unit in a partially filled rack, load the rack from the bottom to the top with the heaviest component at the bottom of the rack.
- If the rack is provided with stabilizing devices, install the stabilizers before mounting or servicing the unit in the rack.

## 2-5 Rack Mounting Instructions

This section provides information on installing the chassis into a rack unit with the rails provided. There are a variety of rack units on the market, which may mean that the assembly procedure will differ slightly from the instructions provided. You should also refer to the installation instructions that came with the rack unit you are using. Note: This rail will fit a rack between 26.5" and 36.4" deep

### Identifying the Sections of the Rack Rails

The chassis package includes a rack rail assembly in the rack mounting kit. Each assembly consists of three sections: An inner chassis rail which secures directly to the chassis, an outer rail that secures to the rack, and a middle rail which extends from the outer rail. These assemblies are specifically designed for the left and right side of the chassis.

### Installing the Inner Rails on the Chassis

#### Installing the Inner Rails

1. Place the inner rails on the side of the chassis aligning the hooks of the chassis with the inner rail holes. Make sure that the rail faces "outward" so that it will fit with the rack's mounting bracket.
2. Slide the rail toward the front of the chassis.

Figure 2-1. Identifying the Different Rail Sections

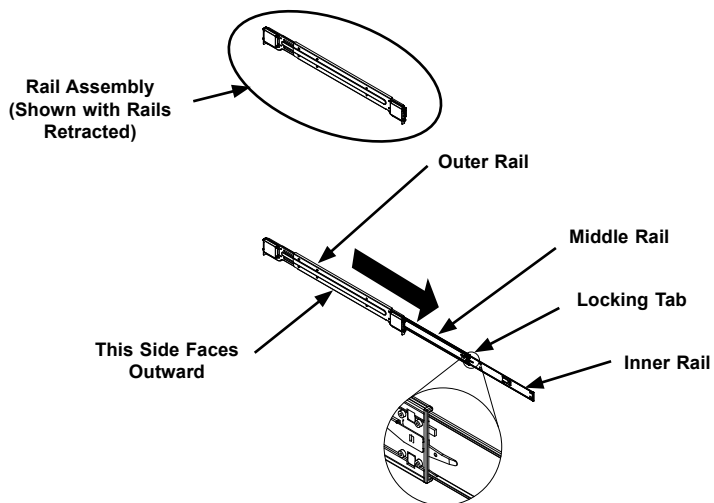

3. Secure the rail to the chassis with four screws as illustrated.
4. Repeat steps 1-3 for the other inner rack rail.

### Locking Tabs

Each inner rail has a locking tab. This tab locks the chassis into place when installed and pushed fully into the rack. These tabs also lock the chassis in place when fully extended from the rack. This prevents the server from coming completely out of the rack when the chassis is pulled out for servicing.

### Releasing the Inner Rail

#### Releasing Inner Rail from the Outer Rails

1. Identify the left and right outer rail assemblies as described on page 5-4.
2. Pull the inner rail out of the outer rail until it is fully extended as illustrated below.
3. Press the locking tab down to release the inner rail.
4. Pull the inner rail all the way out.
5. Repeat steps 1-3 for the second outer rail.

Figure 2-2. Extending and Releasing the Inner Rail

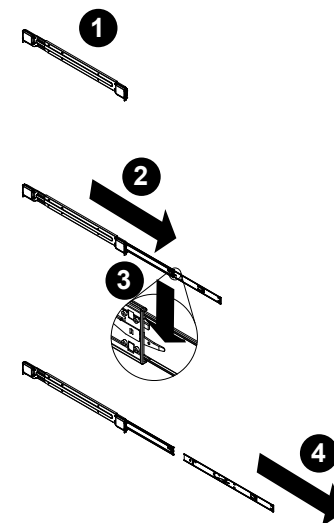

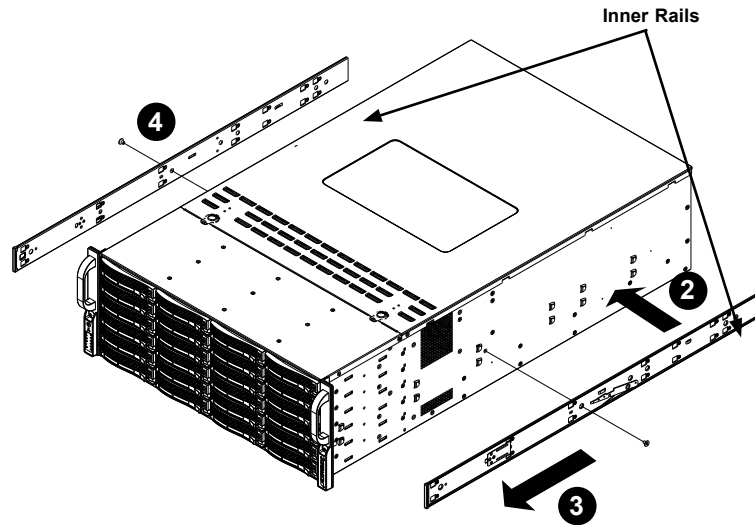

Figure 2-3. Installing the Inner Rails

## Installing The Inner Rails on the Chassis

### Installing the Inner Rails

1. Confirm that the left and right inner rails have been correctly identified.
2. Place the inner rail firmly against the side of the chassis, aligning the hooks on the side of the chassis with the holes in the inner rail.
3. Slide the inner rail forward toward the front of the chassis until the rail clicks into the locked position, which secures the inner rail to the chassis.
4. Secure the inner rail to the chassis with the screws provided.
5. Repeat steps 1 through 4 above for the other inner rail.

**Note:** chassis pictured may vary slightly from the 6048R-E1CR36L system chassis.



**Warning:** When initially installing the server to a rack, test that the rail locking tabs engage to prevent the server from being overextended. Have a rack lift in place as a precaution in case the test fails.



**Warning:** In any instance of pulling the system from the rack, always use a rack lift and follow all associated safety precautions.

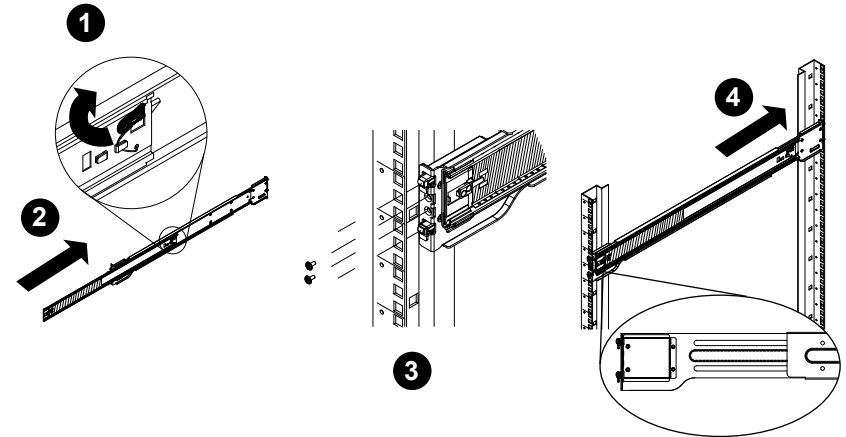

Figure 2-4. Extending and Releasing the Outer Rails

## Installing the Outer Rails on the Rack

### Installing the Outer Rails

1. Press upward on the locking tab at the rear end of the middle rail.
2. Push the middle rail back into the outer rail.
3. Hang the hooks of the front of the outer rail onto the slots on the front of the rack. If necessary, use screws to secure the outer rails to the rack, as illustrated above.
4. Pull out the rear of the outer rail, adjusting the length until it fits within the posts of the rack.
5. Hang the hooks of the rear portion of the outer rail onto the slots on the rear of the rack. If necessary, use screws to secure the rear of the outer rail to the rear of the rack.
6. Repeat steps 1-5 for the remaining outer rail.
7. Pull out the middle rail until it locks to install the server.



**Warning:** do not pick up the server with the front handles. They are designed to pull the system from a rack only.



Slide rail mounted equipment is not to be used as a shelf or a work space.

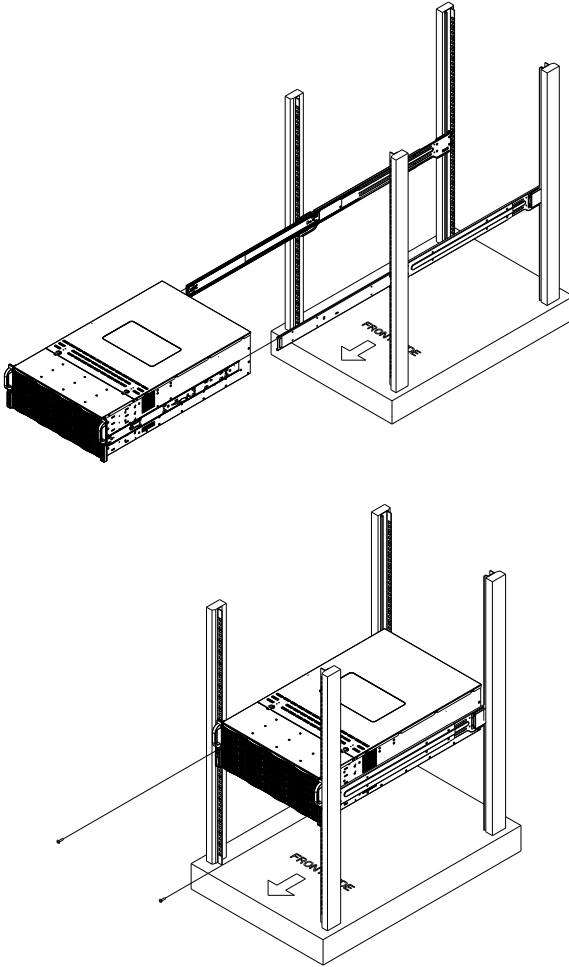

**Figure 2-5. Installing into a Rack**

**Notes:** figures are for illustrative purposes only. Always install servers into racks from the bottom up. The chassis pictured may vary slightly from the 6048R-E1CR36L system chassis.



Stability hazard. The rack stabilizing mechanism must be in place, or the rack must be bolted to the floor before you slide the unit out for servicing. Failure to stabilize the rack can cause the rack to tip over.

## Chapter 3

# System Interface

### 3-1 Overview

There are several LEDs on the control panel as well as others on the drive carriers to keep you constantly informed of the overall status of the system as well as the activity and health of specific components. There are also two buttons on the chassis control panel.

### 3-2 Control Panel Buttons

The two push-buttons located on the front of the chassis are (in order from left to right) a reset button and a power on/off button.

RESET



**Reset**

Use the reset button to reboot the system.



**Power**

This is the main power button, which is used to apply or turn off the main system power. Turning off system power with this button removes the main power but keeps standby power supplied to the system. Therefore, the system power cord should be unplugged before performing service.

### 3-3 Control Panel LEDs

The control panel located on the front of the chassis has several LEDs. These LEDs provide you with critical information related to different parts of the system. This section explains what each LED indicates when illuminated and any corrective action you may need to take.



#### Power Fail

Indicates a power supply module has failed. The second power supply module will take the load and keep the system running but the failed module will need to be replaced. Refer to Chapter 6 for details on replacing the power supply. This LED should be off when the system is operating normally.



#### Information LED

This LED will be blue when the UID function has been activated. When this LED flashes red, it indicates a fan failure. When red continuously it indicates an overhear condition, which may be caused by cables obstructing the airflow in the system or the ambient room temperature being too warm. Check the routing of the cables and make sure all fans are present and operating normally. You should also check to make sure that the chassis covers are installed. Finally, verify that the heatsinks are installed properly (see Chapter 5). This LED will remain flashing or on as long as the indicated condition exists.

Information LED States	
State	Indication
Fast Blinking Red (1x/sec)	Fan Fail
Solid Red	CPU Overheat
Slow Blinking Red (1x/4 sec)	Power Fail
Solid Blue	Local UID Button Depressed
Blinking Blue	IPMI-Activated UID



#### NIC1

Indicates network activity on the LAN1 port when flashing.



#### NIC2

Indicates network activity on the LAN2 port when flashing.



#### HDD

Indicates all HDD channel activity. On the 6048R-E1CR36L, this LED indicates hard drive and/or DVD-ROM drive activity when flashing.



#### Power

Indicates power is being supplied to the system's power supply units. This LED should normally be illuminated when the system is operating.

### 3-4 Drive Carrier LEDs

The chassis includes externally accessible SAS/SATA drives. Each drive carrier displays two status LEDs on the front of the carrier.

LED	LED Color	State	Status
<b>Activity LED</b>	Blue	Solid On	SAS drive installed
	Blue	Blinking	I/O activity
	Blue	Dark/off	SATA drive installed or empty (run I/O to verify)
<b>Status LED</b>	Red	Solid On	Failed drive for SAS/SATA
	Red	Blinking at 1 Hz	Rebuild drive for SAS/SATA
	Red	Blinking with two blinks and one stop at 1 Hz	Hot spare for SAS/SATA
	Red	On for five seconds, then off	Power on for SAS/SATA
	Red	Blinking at 4 Hz	Identify/locate drive for SAS/SATA

## Chapter 4

# Standardized Warning Statements for AC Systems

### 4-1 About Standardized Warning Statements

The following statements are industry standard warnings, provided to warn the user of situations which have the potential for bodily injury. Should you have questions or experience difficulty, contact Supermicro's Technical Support department for assistance. Only certified technicians should attempt to install or configure components.

Read this appendix in its entirety before installing or configuring components in the Supermicro chassis.

These warnings may also be found on our web site at [http://www.supermicro.com/about/policies/safety\\_information.cfm](http://www.supermicro.com/about/policies/safety_information.cfm).

#### Warning Definition



#### Warning!

This warning symbol means danger. You are in a situation that could cause bodily injury. Before you work on any equipment, be aware of the hazards involved with electrical circuitry and be familiar with standard practices for preventing accidents.

#### 警告の定義

この警告サインは危険を意味します。

人身事故につながる可能性がありますので、いずれの機器でも動作させる前に、電気回路に含まれる危険性に注意して、標準的な事故防止策に精通して下さい。

此警告符号代表危險。

您正處於可能受到嚴重傷害的工作環境中。在您使用設備開始工作之前，必須充分意識到觸電的危險，並熟練掌握防止事故發生的標準工作程序。請根據每項警告結尾的聲明號碼找到此設備的安全性警告說明的翻譯文本。

此警告符號代表危險。

您正處於可能身體可能會受損傷的工作環境中。在您使用任何設備之前，請注意觸電的危險，並且要熟悉預防事故發生的標準工作程序。請依照每一注意事項後的號碼找到相關的翻譯說明內容。

**Warnung****WICHTIGE SICHERHEITSHINWEISE**

Dieses Warnsymbol bedeutet Gefahr. Sie befinden sich in einer Situation, die zu Verletzungen führen kann. Machen Sie sich vor der Arbeit mit Geräten mit den Gefahren elektrischer Schaltungen und den üblichen Verfahren zur Vorbeugung vor Unfällen vertraut. Suchen Sie mit der am Ende jeder Warnung angegebenen Anweisungsnummer nach der jeweiligen Übersetzung in den übersetzten Sicherheitshinweisen, die zusammen mit diesem Gerät ausgeliefert wurden.

BEWAHREN SIE DIESE HINWEISE GUT AUF.

**INSTRUCCIONES IMPORTANTES DE SEGURIDAD**

Este símbolo de aviso indica peligro. Existe riesgo para su integridad física. Antes de manipular cualquier equipo, considere los riesgos de la corriente eléctrica y familiarícese con los procedimientos estándar de prevención de accidentes. Al final de cada advertencia encontrará el número que le ayudará a encontrar el texto traducido en el apartado de traducciones que acompaña a este dispositivo.

GUARDE ESTAS INSTRUCCIONES.

**IMPORTANTES INFORMATIONS DE SÉCURITÉ**

Ce symbole d'avertissement indique un danger. Vous vous trouvez dans une situation pouvant entraîner des blessures ou des dommages corporels. Avant de travailler sur un équipement, soyez conscient des dangers liés aux circuits électriques et familiarisez-vous avec les procédures couramment utilisées pour éviter les accidents. Pour prendre connaissance des traductions des avertissements figurant dans les consignes de sécurité traduites qui accompagnent cet appareil, référez-vous au numéro de l'instruction situé à la fin de chaque avertissement.

CONSERVEZ CES INFORMATIONS.

**תקנון הצהרות אזהרה**

הצהרות הבאות הן אזהרות על פי תקני התעשייה, על מנת להזהיר את המשתמש מפני חבלה פיזית אפשרית. במידה ויש שאלות או היתקלות בבעיה כלשהי, יש ליצור קשר עם מחלקת תמיכה טכנית של סופרמיקרו. טכנאים מוסמכים בלבד רשאים להתקין או להגדיר את הרכיבים.

יש לקרוא את הנספח במלואו לפני התקנת או הגדרת הרכיבים במאוזן סופרמיקרו.

تحذير! هذا الرمز يعني خطر انك في حالة يمكن أن تتسبب في اصابة جسدية .  
قبل أن تعمل على أي معدات، كن على علم بالمخاطر الناجمة عن الدوائر  
الكهربائية  
وكن على دراية بالممارسات الوقائية لمنع وقوع أي حوادث  
استخدم رقم البيان المنصوص في نهاية كل تحذير للعثور ترجمتها

안전을 위한 주의사항

경고!

이 경고 기호는 위험이 있음을 알려 줍니다. 작업자의 신체에 부상을 야기 할 수 있는 상태에 있게 됩니다. 모든 장비에 대한 작업을 수행하기 전에 전기회로와 관련된 위험요소들을 확인하시고 사전에 사고를 방지할 수 있도록 표준 작업절차를 준수해 주시기 바랍니다.

해당 번역문을 찾기 위해 각 경고의 마지막 부분에 제공된 경고문 번호를 참조하십시오

**BELANGRIJKE VEILIGHEIDSINSTRUCTIES**

Dit waarschuwings symbool betekent gevaar. U verkeert in een situatie die lichamelijk letsel kan veroorzaken. Voordat u aan enige apparatuur gaat werken, dient u zich bewust te zijn van de bij een elektrische installatie betrokken risico's en dient u op de hoogte te zijn van de standaard procedures om ongelukken te voorkomen. Gebruik de nummers aan het eind van elke waarschuwing om deze te herleiden naar de desbetreffende locatie.

BEWAAR DEZE INSTRUCTIES

## Installation Instructions



### Warning!

Read the installation instructions before connecting the system to the power source.

設置手順書

システムを電源に接続する前に、設置手順書をお読み下さい。

警告

将此系统连接电源前, 请先阅读安装说明。

警告

將系統與電源連接前, 請先閱讀安裝說明。

Warnung

Vor dem Anschließen des Systems an die Stromquelle die Installationsanweisungen lesen.

¡Advertencia!

Lea las instrucciones de instalación antes de conectar el sistema a la red de alimentación.

Attention

Avant de brancher le système sur la source d'alimentation, consulter les directives d'installation.

יש לקרוא את הוראות התקנה לפני חיבור המערכת למקור מתח.

اقر إرشادات التركيب قبل توصيل النظام إلى مصدر للطاقة

시스템을 전원에 연결하기 전에 설치 안내를 읽어주십시오.

Waarschuwing

Raadpleeg de installatie-instructies voordat u het systeem op de voedingsbron aansluit.

## Circuit Breaker



### Warning!

This product relies on the building's installation for short-circuit (overcurrent) protection. Ensure that the protective device is rated not greater than: 250 V, 20 A.

サーキット・ブレーカー

この製品は、短絡(過電流)保護装置がある建物での設置を前提としています。

保護装置の定格が250 V、20 Aを超えないことを確認下さい。

警告

此产品的短路(过载电流)保护由建筑物的供电系统提供, 确保短路保护设备的额定电流不大于250V, 20A。

警告

此產品的短路(過載電流)保護由建築物的供電系統提供, 確保短路保護設備的額定電流不大於250V, 20A。

Warnung

Dieses Produkt ist darauf angewiesen, dass im Gebäude ein Kurzschluss- bzw. Überstromschutz installiert ist. Stellen Sie sicher, dass der Nennwert der Schutzvorrichtung nicht mehr als: 250 V, 20 A beträgt.

¡Advertencia!

Este equipo utiliza el sistema de protección contra cortocircuitos (o sobrecorrientes) del edificio. Asegúrese de que el dispositivo de protección no sea superior a: 250 V, 20 A.

Attention

Pour ce qui est de la protection contre les courts-circuits (surtension), ce produit dépend de l'installation électrique du local. Vérifiez que le courant nominal du dispositif de protection n'est pas supérieur à : 250 V, 20 A.

מוצר זה מסתמך על הגנה המותקנת במבנים למניעת קצר חשמלי. יש לוודא המכשיר המגן מפני הקצר החשמלי הוא לא יותר מ-20A, 60VDC

هذا المنتج يعتمد على معدات الحماية التي تم تثبيتها في المبنى

تأكد من أن تقيهم الجهاز الوقائي ليس أكثر من: 20A, 250VDC

경고!

이 제품은 전원의 단락(과전류)방지에 대해서 전적으로 건물의 관련 설비에 의존합니다. 보호장치의 정격이 반드시 250V(볼트), 20A(암페어)를 초과하지 않도록 해야 합니다.

Waarschuwing

Dit product is afhankelijk van de kortsluitbeveiliging (overspanning) van uw elektrische installatie. Controleer of het beveiligde apparaat niet groter gedimensioneerd is dan 220V, 20A.

### Power Disconnection Warning



**Warning!**

The system must be disconnected from all sources of power and the power cord removed from the power supply module(s) before accessing the chassis interior to install or remove system components.

電源切斷の警告

システムコンポーネントの取り付けまたは取り外しのために、シャーシー内部にアクセスするには、

システムの電源はすべてのソースから切斷され、電源コードは電源モジュールから取り外す必要があります。

警告

在你打开机箱并安装或移除内部器件前，必须将系统完全断电，并移除电源线。

警告

在您打開機殼安裝或移除內部元件前，必須將系統完全斷電，並移除電源線。

Warnung

Das System muss von allen Quellen der Energie und vom Netzanschlusskabel getrennt sein, das von den Spg.Versorgungsteilmodulen entfernt wird, bevor es auf den Chassisinnenraum zurückgreift, um Systemsbestandteile anzubringen oder zu entfernen.

¡Advertencia!

El sistema debe ser desconectado de todas las fuentes de energía y del cable eléctrico quitado de los módulos de fuente de alimentación antes de tener acceso el interior del chasis para instalar o para quitar componentes de sistema.

Attention

Le système doit être débranché de toutes les sources de puissance ainsi que de son cordon d'alimentation secteur avant d'accéder à l'intérieur du châssis pour installer ou enlever des composants de système.

**אזהרה!**

יש לנתק את המערכת מכל מקורות החשמל ויש להסיר את כבל החשמלי מהספק לפני גישה לחלק הפנימי של המארז לצורך התקנת או הסרת רכיבים.

يجب فصل النظام من جميع مصادر الطاقة وإزالة سلك الكهرباء من وحدة امداد الطاقة قبل

الوصول إلى المناطق الداخلية للهيكल لتنشيت أو إزالة مكونات الجهاز

경고!

시스템에 부품들을 장착하거나 제거하기 위해서는 새시 내부에 접근하기 전에 반드시 전원 공급장치로부터 연결되어있는 모든 전원과 전기코드를 분리해주어야 합니다.

Waarschuwing

Voordat u toegang neemt tot het binnenwerk van de behuizing voor het installeren of verwijderen van systeem onderdelen, dient u alle spanningsbronnen en alle stroomkabels aangesloten op de voeding(en) van de behuizing te verwijderen

## Equipment Installation



### Warning!

Only trained and qualified personnel should be allowed to install, replace, or service this equipment.

#### 機器の設置

トレーニングを受け認定された人だけがこの装置の設置、交換、またはサービスを許可されています。

#### 警告

只有经过培训且具有资格的人员才能进行此设备的安装、更换和维修。

#### 警告

只有經過受訓且具資格人員才可安裝、更換與維修此設備。

#### Warnung

Das Installieren, Ersetzen oder Bedienen dieser Ausrüstung sollte nur geschultem, qualifiziertem Personal gestattet werden.

#### ¡Advertencia!

Solamente el personal calificado debe instalar, reemplazar o utilizar este equipo.

#### Attention

Il est vivement recommandé de confier l'installation, le remplacement et la maintenance de ces équipements à des personnels qualifiés et expérimentés.

#### אזהרה!

צוות מוסמך בלבד רשאי להתקין, להחליף את הציוד או לתת שירות עבור הציוד.

يجب أن يسمح فقط للموظفين المؤهلين والمدربين لتكيب واستبدال أو خدمة هذا الجهاز

#### 경고!

훈련을 받고 공인된 기술자만이 이 장비의 설치, 교체 또는 서비스를 수행할 수 있습니다.

#### Waarschuwing

Deze apparatuur mag alleen worden geïnstalleerd, vervangen of hersteld door geschoold en gekwalificeerd personeel.

## Restricted Area



### Warning!

This unit is intended for installation in restricted access areas. A restricted access area can be accessed only through the use of a special tool, lock and key, or other means of security. (This warning does not apply to workstations).

#### アクセス制限区域

このユニットは、アクセス制限区域に設置されることを想定しています。

アクセス制限区域は、特別なツール、鍵と錠前、その他のセキュリティの手段を用いてのみ出入りが可能です。

#### 警告

此部件应安装在限制进出的场所，限制进出的场所指只能通过使用特殊工具、锁和钥匙或其它安全手段进出的场所。

#### 警告

此裝置僅限安裝於進出管制區域，進出管制區域係指僅能以特殊工具、鎖頭及鑰匙或其他安全方式才能進入的區域。

#### Warnung

Diese Einheit ist zur Installation in Bereichen mit beschränktem Zutritt vorgesehen. Der Zutritt zu derartigen Bereichen ist nur mit einem Spezialwerkzeug, Schloss und Schlüssel oder einer sonstigen Sicherheitsvorkehrung möglich.

#### ¡Advertencia!

Esta unidad ha sido diseñada para instalación en áreas de acceso restringido. Sólo puede obtenerse acceso a una de estas áreas mediante la utilización de una herramienta especial, cerradura con llave u otro medio de seguridad.

#### Attention

Cet appareil doit être installé dans des zones d'accès réservés. L'accès à une zone d'accès réservé n'est possible qu'en utilisant un outil spécial, un mécanisme de verrouillage et une clé, ou tout autre moyen de sécurité.

**אזור עם גישה מוגבלת****אזהרה!**

יש להתקין את היחידה באזורים שיש בהם הגבלת גישה. הגישה ניתנת בעזרת כלי אבטחה בלבד (מפתח, מנעול וכד').

تم تخصيص هذه الوحدة لتركيبها في مناطق محظورة . يمكن الوصول إلى منطقة محظورة فقط من خلال استخدام أداة خاصة، قفل ومفتاح أو أي وسيلة أخرى للأمان

경고!

이 장치는 접근이 제한된 구역에 설치하도록 되어 있습니다. 특수도구, 잠금 장치 및 키, 또는 기타 보안 수단을 통해서만 접근 제한 구역에 들어갈 수 있습니다.

Waarschuwing

Dit apparaat is bedoeld voor installatie in gebieden met een beperkte toegang. Toegang tot dergelijke gebieden kunnen alleen verkregen worden door gebruik te maken van speciaal gereedschap, slot en sleutel of andere veiligheidsmaatregelen.

**Battery Handling****Warning!**

There is the danger of explosion if the battery is replaced incorrectly. Replace the battery only with the same or equivalent type recommended by the manufacturer. Dispose of used batteries according to the manufacturer's instructions

電池の取り扱い

電池交換が正しく行われなかった場合、破裂の危険性があります。交換する電池はメーカーが推奨する型、または同等のものを使用下さい。使用済電池は製造元の指示に従って処分して下さい。

警告

電池更換不當會有爆炸危險。請只使用同類電池或製造商推薦的功能相當的電池更換原有電池。請按製造商的說明處理廢舊電池。

警告

電池更換不當會有爆炸危險。請使用製造商建議之相同或功能相當的電池更換原有電池。請按照製造商的說明指示處理廢棄舊電池。

Warnung

Bei Einsetzen einer falschen Batterie besteht Explosionsgefahr. Ersetzen Sie die Batterie nur durch den gleichen oder vom Hersteller empfohlenen Batterietyp. Entsorgen Sie die benutzten Batterien nach den Anweisungen des Herstellers.

Attention

Danger d'explosion si la pile n'est pas remplacée correctement. Ne la remplacer que par une pile de type semblable ou équivalent, recommandée par le fabricant. Jeter les piles usagées conformément aux instructions du fabricant.

¡Advertencia!

Existe peligro de explosión si la batería se reemplaza de manera incorrecta. Reemplazar la batería exclusivamente con el mismo tipo o el equivalente recomendado por el fabricante. Desechar las baterías gastadas según las instrucciones del fabricante.

**אזהרה!**

קיימת סכנת פיצוץ של הסוללה במידה והוחלפה בדרך לא תקינה. יש להחליף את הסוללה בסוג התואם מחברת יצרן מומלצת.

סילוק הסוללות המשומשות יש לבצע לפי הוראות היצרן.

هناك خطر من انفجار في حالة استبدال البطارية بطريقة غير صحيحة فعليك استبدال البطارية فقط بنفس النوع أو ما يعادلها كما أوصت به الشركة المصنعة تخلص من البطاريات المستعملة وفقا لتعليمات الشركة الصانعة

경고!

배터리가 올바르게 교체되지 않으면 폭발의 위험이 있습니다. 기존 배터리와 동일하거나 제조사에서 권장하는 동등한 종류의 배터리로만 교체해야 합니다. 제조사의 안내에 따라 사용된 배터리를 처리하여 주십시오.

Waarschuwing

Er is ontploffingsgevaar indien de batterij verkeerd vervangen wordt. Vervang de batterij slechts met hetzelfde of een equivalent type die door de fabrikant aanbevolen wordt. Gebruikte batterijen dienen overeenkomstig fabrieksvoorschriften afgevoerd te worden.

## Redundant Power Supplies



### Warning!

This unit might have more than one power supply connection. All connections must be removed to de-energize the unit.

### 冗長電源装置

このユニットは複数の電源装置が接続されている場合があります。  
ユニットの電源を切るためには、すべての接続を取り外さなければなりません。

### 警告

此部件连接的电源可能不止一个，必须将所有电源断开才能停止给该部件供电。

### 警告

此裝置連接的電源可能不只一個，必須切斷所有電源才能停止對該裝置的供電。

### Warnung

Dieses Gerät kann mehr als eine Stromzufuhr haben. Um sicherzustellen, dass der Einheit kein Strom zugeführt wird, müssen alle Verbindungen entfernt werden.

### ¡Advertencia!

Puede que esta unidad tenga más de una conexión para fuentes de alimentación. Para cortar por completo el suministro de energía, deben desconectarse todas las conexiones.

### Attention

Cette unité peut avoir plus d'une connexion d'alimentation. Pour supprimer toute tension et tout courant électrique de l'unité, toutes les connexions d'alimentation doivent être débranchées.

## אם קיים יותר מספק אחד

### אזהרה!

ליחידה יש יותר מחיבור אחד של ספק. יש להסיר את כל החיבורים על מנת לרוקן את היחידה.

قد يكون لهذا الجهاز عدة اتصالات بوحدة امداد الطاقة.  
يجب إزالة كافة الاتصالات لعزل الوحدة عن الكهرباء

### 경고!

이 장치에는 한 개 이상의 전원 공급 단자가 연결되어 있을 수 있습니다. 이 장치에 전원을 차단하기 위해서는 모든 연결 단자를 제거해야만 합니다.

### Waarschuwing

Deze eenheid kan meer dan één stroomtoevoeraansluiting bevatten. Alle aansluitingen dienen verwijderd te worden om het apparaat stroomloos te maken.

## Backplane Voltage



### Warning!

Hazardous voltage or energy is present on the backplane when the system is operating. Use caution when servicing.

### バックプレーンの電圧

システムの稼働中は危険な電圧または電力が、バックプレーン上にかかっています。  
修理するにはご注意ください。

### 警告

当系统正在进行时，背板上有很危险的电压或能量，进行维修时务必小心。

### 警告

當系統正在進行時，背板上有危險的電壓或能量，進行維修時務必小心。

### Warnung

Wenn das System in Betrieb ist, treten auf der Rückwandplatine gefährliche Spannungen oder Energien auf. Vorsicht bei der Wartung.

### ¡Advertencia!

Quando el sistema está en funcionamiento, el voltaje del plano trasero es peligroso. Tenga cuidado cuando lo revise.

### Attention

Lorsque le système est en fonctionnement, des tensions électriques circulent sur le fond de panier. Prendre des précautions lors de la maintenance.

**מתח בפנל האחורי****אזהרה!**

קיימת סכנת מתח בפנל האחורי בזמן תפעול המערכת. יש להיזהר במהלך העבודה.

هناك خطر من التيار الكهربائي أو الطاقة الموجودة على اللوحة عندما يكون النظام يعمل كن حذرا عند خدمة هذا الجهاز

경고!

시스템이 동작 중일 때 후면판 (Backplane)에는 위험한 전압이나 에너지가 발생 합니다. 서비스 작업 시 주의하십시오.

**Waarschuwing**

Een gevaarlijke spanning of energie is aanwezig op de backplane wanneer het systeem in gebruik is. Voorzichtigheid is geboden tijdens het onderhoud.

**Comply with Local and National Electrical Codes****Warning!**

Installation of the equipment must comply with local and national electrical codes.

地方および国の電気規格に準拠

機器の取り付けはその地方および国の電気規格に準拠する必要があります。

警告

设备安装必须符合本地与本国电气法规。

警告

設備安裝必須符合本地與本國電氣法規。

**Warnung**

Die Installation der Geräte muss den Sicherheitsstandards entsprechen.

¡Advertencia!

La instalación del equipo debe cumplir con las normas de electricidad locales y nacionales.

Attention

L'équipement doit être installé conformément aux normes électriques nationales et locales.

**תיאום חוקי החשמל הארצי****אזהרה!**

התקנת הציוד חייבת להיות תואמת לחוקי החשמל המקומיים והארציים.

تركيب المعدات الكهربائية يجب أن يمتثل للقوانين المحلية والوطنية المتعلقة بالكهرباء

경고!

현 지역 및 국가의 전기 규정에 따라 장비를 설치해야 합니다.

**Waarschuwing**

Bij installatie van de apparatuur moet worden voldaan aan de lokale en nationale elektriciteitsvoorschriften.

**Product Disposal****Warning!**

Ultimate disposal of this product should be handled according to all national laws and regulations.

製品の廃棄

この製品を廃棄処分する場合、国の関係する全ての法律・条例に従い処理する必要があります。

警告

本产品的废弃处理应根据所有国家的法律和规章进行。

警告

本产品的廢棄處理應根據所有國家的法律和規章進行。

**Warnung**

Die Entsorgung dieses Produkts sollte gemäß allen Bestimmungen und Gesetzen des Landes erfolgen.

**¡Advertencia!**

Al deshacerse por completo de este producto debe seguir todas las leyes y reglamentos nacionales.

**Attention**

La mise au rebut ou le recyclage de ce produit sont généralement soumis à des lois et/ou directives de respect de l'environnement. Renseignez-vous auprès de l'organisme compétent.

**סילוק המוצר****אזהרה !**

סילוק סופי של מוצר זה חייב להיות בהתאם להנחיות וחוקי המדינה.

عند التخلص النهائي من هذا المنتج ينبغي التعامل معه وفقا لجميع القوانين واللوائح الوطنية

**경고!**

이 제품은 해당 국가의 관련 법규 및 규정에 따라 폐기되어야 합니다.

**Waarschuwing**

De uiteindelijke verwijdering van dit product dient te geschieden in overeenstemming met alle nationale wetten en reglementen.

**Hot Swap Fan Warning****Warning!**

The fans might still be turning when you remove the fan assembly from the chassis. Keep fingers, screwdrivers, and other objects away from the openings in the fan assembly's housing.

**ファン・ホットスワップの警告**

シャーシから冷却ファン装置を取り外した際、ファンがまだ回転している可能性があります。ファンの開口部に、指、ドライバー、およびその他のものを近づけないで下さい。

**警告**

当您从机架移除风扇装置，风扇可能仍在转动。小心不要将手指、螺丝起子和其他物品太靠近风扇。

**警告**

當您從機架移除風扇裝置，風扇可能仍在轉動。小心不要將手指、螺絲起子和其他物品太靠近風扇。

**Warnung**

Die Lüfter drehen sich u. U. noch, wenn die Lüfterbaugruppe aus dem Chassis genommen wird. Halten Sie Finger, Schraubendreher und andere Gegenstände von den Öffnungen des Lüftergehäuses entfernt.

**¡Advertencia!**

Los ventiladores podran dar vuelta cuando usted quite el montaje del ventilador del chasis. Mantenga los dedos, los destornilladores y todos los objetos lejos de las aberturas del ventilador

**Attention**

Il est possible que les ventilateurs soient toujours en rotation lorsque vous retirez le bloc ventilateur du châssis. Prenez garde à ce que doigts, tournevis et autres objets soient éloignés du logement du bloc ventilateur.

**אזהרה !**

כאשר מסירים את חלקי המאוורר מהמארז, יתכן והמאווררים עדיין עובדים. יש להרחיק למרחק בטוח את האצבעות וכלי עבודה שונים מהפתחים בתוך המאוורר

من الممكن أن المراوح لا تزال تدور عند إزالة كتلة المروحة من الهيكل يجب إبقاء الأصابع ومفكات البراغي وغيرها من الأشياء بعيدا عن الفتحات في كتلة المروحة.

**경고!**

새시로부터 팬 조립품을 제거할 때 팬은 여전히 회전하고 있을 수 있습니다. 팬 조립품 외곽의 열려있는 부분들로부터 손가락 및 스크류드라이버, 다른 물체들이 가까이 하지 않도록 배치해 주십시오.

**Waarschuwing**

Het is mogelijk dat de ventilator nog draait tijdens het verwijderen van het ventilatorsamenstel uit het chassis. Houd uw vingers, schroevendraaiers en eventuele andere voorwerpen uit de buurt van de openingen in de ventilatorbehuizing.

## Power Cable and AC Adapter



### Warning!

When installing the product, use the provided or designated connection cables, power cables and AC adaptors. Using any other cables and adaptors could cause a malfunction or a fire. Electrical Appliance and Material Safety Law prohibits the use of UL or CSA -certified cables (that have UL/CSA shown on the code) for any other electrical devices than products designated by Supermicro only.

#### 電源コードとACアダプター

製品を設置する場合、提供または指定された接続ケーブル、電源コードとACアダプターを使用下さい。他のケーブルやアダプタを使用すると故障や火災の原因になることがあります。電気用品安全法は、ULまたはCSA認定のケーブル(UL/CSEマークがコードに表記)を Supermicroが指定する製品以外に使用することを禁止しています。

#### 警告

安装此产品时,请使用本身提供的或指定的连接线,电源线和电源适配器.使用其它线材或适配器可能会引起故障或火灾。除了Supermicro所指定的产品,电气用品和材料安全法律规定禁止使用未经UL或CSA认证的线材。(线材上会显示UL/CSA符号)。

#### 警告

安裝此產品時,請使用本身提供的或指定的連接線,電源線和電源適配器.使用其它線材或適配器可能會引起故障或火災。除了Supermicro所指定的產品,電氣用品和材料安全法律規定禁止使用未經UL或CSA認證的線材。(線材上會顯示UL/CSA符號)。

#### Warnung

Bei der Installation des Produkts, die zur Verfügung gestellten oder benannt Anschlusskabel, Stromkabel und Netzteile. Verwendung anderer Kabel und Adapter kann zu einer Fehlfunktion oder ein Brand entstehen. Elektrische Geräte und Material Safety Law verbietet die Verwendung von UL-oder CSA-zertifizierte Kabel, UL oder CSA auf der Code für alle anderen elektrischen Geräte als Produkte von Supermicro nur bezeichnet gezeigt haben.

#### ¡Advertencia!

Al instalar el producto, utilice los cables de conexión previstos o designados, los cables y adaptadores de CA. La utilización de otros cables y adaptadores podría ocasionar un mal funcionamiento o un incendio. Aparatos Eléctricos y la Ley de Seguridad del Material prohíbe el uso de UL o CSA cables certificados que tienen UL o CSA se muestra en el código de otros dispositivos eléctricos que los productos designados por Supermicro solamente.

#### Attention

Lors de l'installation du produit, utilisez les bables de connection fournis ou désigné. L'utilisation d'autres cables et adaptateurs peut provoquer un dysfonctionnement ou un incendie. Appareils électroménagers et de loi sur la sécurité Matériel interdit l'utilisation de UL ou CSA câbles certifiés qui ont UL ou CSA indiqué sur le code pour tous les autres appareils électriques que les produits désignés par Supermicro seulement.

#### חשמליים ומתאמי AC

#### אזהרה!

כאשר מתקינים את המוצר, יש להשתמש בכבלים, ספקים ומתאמים AC אשר נועדו וסופקו לשם כך. שימוש בכל כבל או מתאם אחר יכול לגרום לתקלה או קצר חשמלי. על פי חוקי שימוש במכשירי חשמל וחוקי בטיחות, קיים איסור להשתמש בכבלים המוסמכים ב- UL או ב- CSA (כשאר מופיע עליהם קוד של UL/CSA) עבור כל מוצר חשמלי אחר שלא צוין על ידי סופרמיקרו בלבד.

عند تركيب الجهاز يجب استخدام كابلات التوصيل، والكابلات الكهربائية ومحولات التيار المتردد

التي . أن استخدام أي كابلات ومحولات أخرى يتسبب في حدوث عطل أو حريق. تم توفيرها لك مع المنتج

الأجهزة الكهربائية ومواد قانون السلامة يحظر استخدام الكابلات CSA أو UL معتمدة من قبل

لأي أجهزة كهربائية أخرى غير المنتجات المعينة من قبل Supermicro (التي تحمل علامة UL/CSA)

#### 경고!

제품을 설치할 때에는 제공되거나 지정된 연결케이블과 전원케이블, AC어댑터를 사용해야 합니다. 그 밖의 다른 케이블들이나 어댑터들은 고장 또는 화재의 원인이 될 수 있습니다. 전기용품안전법 (Electrical Appliance and Material Safety Law)은 슈퍼마이크로에서 지정한 제품들 외에는 그 밖의 다른 전기 장치들을 위한 UL또는 CSA에서 인증한 케이블(전선 위에 UL/CSA가 표시)들의 사용을 금지합니다.

#### Waarschuwing

Bij het installeren van het product, gebruik de meegeleverde of aangewezen kabels, stroomkabels en adapters. Het gebruik van andere kabels en adapters kan leiden tot een storing of een brand. Elektrisch apparaat en veiligheidsinformatiebladen wet verbiedt het gebruik van UL of CSA gecertificeerde kabels die UL of CSA die op de code voor andere elektrische apparaten dan de producten die door Supermicro alleen.

**Notes**

## Chapter 5

### Advanced Serverboard Setup

This chapter is provided as a reference and describes the data and power cable connections and add-on cards. All serverboard jumpers and connections are also described. A layout and quick reference chart are included in this chapter for your reference. Remember to completely close the chassis when you have finished working with the serverboard to better cool and protect the system.

#### 5-1 Handling the Serverboard

Electrostatic Discharge (ESD) can damage electronic components. To prevent damage to any printed circuit boards (PCBs), it is important to handle them very carefully (see previous chapter). To prevent the serverboard from bending, keep one hand under the center of the board to support it when handling. The following measures are generally sufficient to protect your equipment from electric static discharge.

##### Precautions

- Use a grounded wrist strap designed to prevent Electrostatic Discharge (ESD).
- Touch a grounded metal object before removing any board from its antistatic bag.
- Handle a board by its edges only; do not touch its components, peripheral chips, memory modules or gold contacts.
- When handling chips or modules, avoid touching their pins.
- Put the serverboard, add-on cards and peripherals back into their antistatic bags when not in use.
- For grounding purposes, make sure your computer chassis provides excellent conductivity between the power supply, the case, the mounting fasteners and the serverboard.

## 5-2 Connecting Cables

Several cables need to be connected to the serverboard. These include the data cables for the peripherals and control panel and the power cables.

### Connecting Data Cables

The cables used to transfer data from the peripheral devices have been carefully routed to prevent them from blocking the flow of cooling air that moves through the system from front to back. If you need to disconnect any of these cables, you should take care to keep them routed as they were originally after reconnecting them (make sure the red wires connect to the pin 1 locations). See the layout on page 5-10 for connector locations.

### Connecting Power Cables

The X10DRH-iT has a 24-pin primary power supply connector (J24) for connection to the ATX power supply. In addition, there are two 8-pin 12V processor power connectors (JPWR1 and JPWR2) that must be connected to your power supply. See Section 5-9 for power connector pin definitions.

### Connecting the Control Panel

JF1 contains header pins for various front control panel connectors. See Figure 5-1 for the pin locations of the various front control panel buttons and LED indicators.

All JF1 wires have been bundled into a single cable to simplify this connection. Make sure the red wire plugs into pin 1 as marked on the board. The other end connects to the Control Panel PCB board, located just behind the system status LEDs on the chassis. See Chapter 5 for details and pin descriptions.

Figure 5-1. Control Panel Header Pins

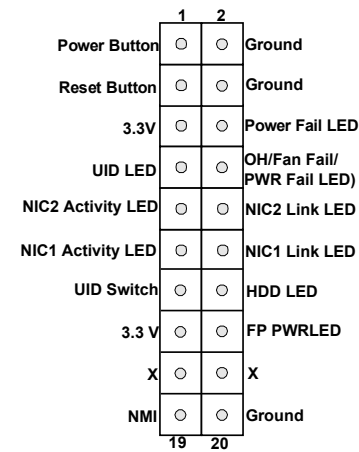

## 5-3 Rear I/O Ports

See Figure 5-2 below for the locations of the various I/O ports.

Figure 5-2. Rear I/O Ports

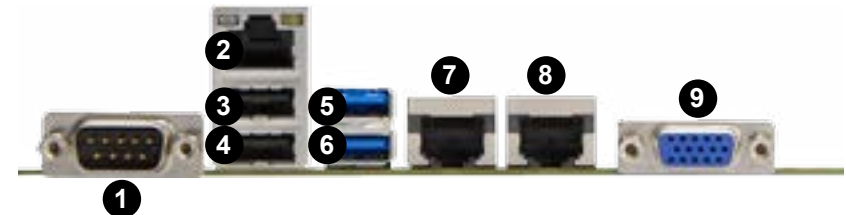

Rear I/O Ports			
1	COM Port 1	6	USB Port 4
2	Dedicated IPMI LAN	7	TLAN Port 1
3	USB Port 1	8	TLAN Port 2
4	USB Port 0	9	VGA Port
5	USB Port 5		

**Note:** a UID (Unit Identifier) button and LED is located to the right of the VGA port (not pictured).

## 5-4 Installing the Processor and Heatsink

**Warning:** When handling the processor package, avoid placing direct pressure on the label area of the fan.

### Notes:

- Always connect the power cord last and always remove it before adding, removing or changing any hardware components. Make sure that you install the processor into the CPU socket before you install the CPU heatsink.
- If you buy a CPU separately, make sure that you use an Intel-certified multi-directional heatsink only.
- Make sure to install the serverboard into the chassis before you install the CPU heatsinks.
- When receiving a serverboard without a processor pre-installed, make sure that the plastic CPU socket cap is in place and none of the socket pins are bent; otherwise, contact your retailer immediately.
- Refer to the Supermicro web site for updates on CPU support.

### Installing an LGA2011 Processor

1. There are two levers on the LGA2011 socket. First press and release the load lever labeled 'Open 1st'.
2. Press the second load lever labeled 'Close 1st' to release the load plate from its locked position.

Press down on the lever labeled 'Close 1st'

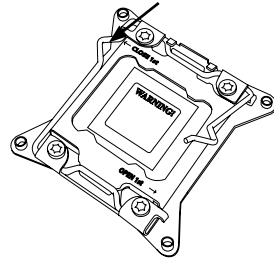

Pull lever away from the socket

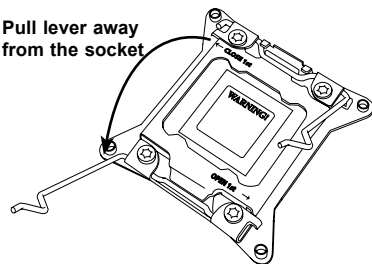

3. With the lever labeled 'Close 1st' fully retracted, gently push down on the 'Open 1st' lever to open the load plate. Lift the load plate to open it completely.
4. Using your thumb and the index finger, remove the 'WARNING' plastic cap from the socket.
5. Use your thumb and index finger to hold the CPU by its edges. Align the CPU keys, which are semi-circle cutouts, against the socket keys.
6. Once they are aligned, carefully lower the CPU straight down into the socket. (Do not drop the CPU on the socket. Do not move the CPU horizontally or vertically and do not rub the CPU against any pins of the socket, which may damage the CPU or the socket.)

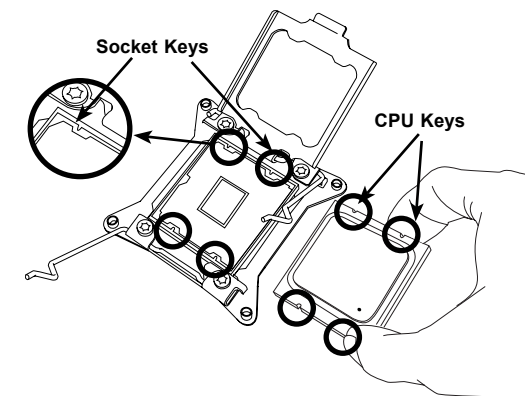
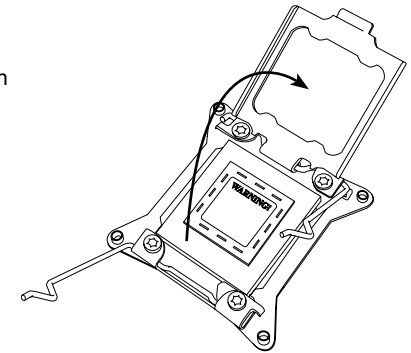
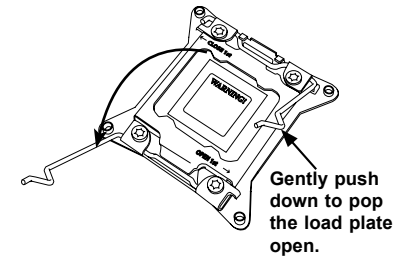

**Warning:** You can only install the CPU to the socket in one direction. Make sure that the CPU is properly inserted into the socket before closing the load plate. If it doesn't close properly, do not force it as it may damage your CPU. Instead, open the load plate again and double-check that the CPU is aligned properly.

7. With the CPU in the socket, inspect the four corners of the CPU to make sure that they are flush with the socket.
8. Close the load plate. Lock the lever labeled 'Close 1st', then lock the lever labeled 'Open 1st'. Use your thumb to gently push the load levers down until the lever locks.

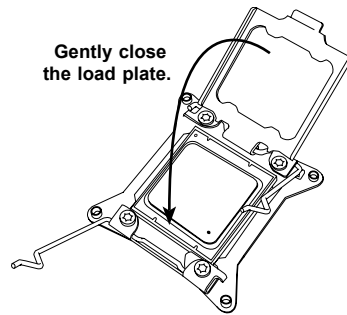

Push down and lock the level labeled 'Close 1st'.

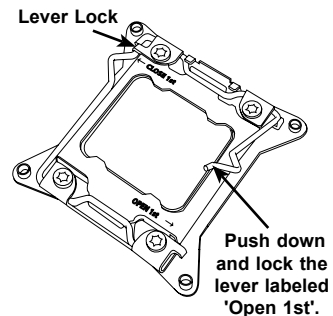
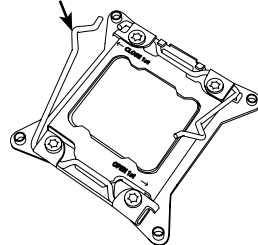

## Installing a Passive CPU Heatsink

1. Do not apply any thermal grease to the heatsink or the CPU die. The required amount has already been applied.
2. Place the heatsink on top of the CPU so that the four mounting holes are aligned with those on the serverboard and the heatsink bracket underneath.
3. Screw in two diagonal screws (i.e., the #1 and the #2 screws) until just snug (do not over-tighten the screws to avoid possible damage to the CPU.)
4. Finish the installation by fully tightening all four screws.

Figure 5-3. Installing a Heatsink

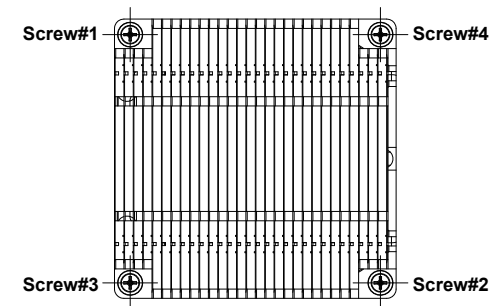

## Removing the Heatsink

**Warning:** We do not recommend that the CPU or the heatsink be removed. However, if you do need to uninstall the heatsink, please follow the instructions below to uninstall the heatsink to prevent damage done to the CPU or the CPU socket.

1. Unscrew the heatsink screws from the serverboard in the sequence as shown in the illustration above.
2. Gently wriggle the heatsink to loosen it from the CPU. (Do not use excessive force when wriggling the heatsink!)
3. Once the heatsink is loose, remove it from the CPU.
4. Remove the used thermal grease and clean the surface of the CPU and the heatsink, Reapply the proper amount of thermal grease on the surface before reinstalling the heatsink.

**Warning:** Do not reuse old thermal grease!

## 5-5 Installing Memory

**Caution:** Exercise extreme care when installing or removing DIMM modules to prevent any possible damage.

### Memory Support

The X10DRH-iT has 16 DIMM slots that can support up to 2 TB of ECC LRDIMM (Load Reduced DIMM) or 1 TB of ECC RDIMM (Registered DIMM) DDR4-2400/2133/1866/1600 memory. For best performance, install pairs of memory modules of the same type and speed. Please refer to our website for any updates to supported memory. All channels will run at the fastest common frequency.

### DIMM Installation

#### Installing Memory Modules

1. Insert the desired number of DIMMs into the memory slots starting with P1-DIMMA1. See the Memory Installation Tables on the following pages.
2. Insert each DIMM module vertically into its slot. Pay attention to the notch along the bottom of the module to avoid installing incorrectly (see Figure 5-3).
3. Use your thumbs to gently press down on both ends of the DIMM module until it snaps into place in the slot. Repeat for all modules.
4. Press the release tabs to the locked positions to secure the DIMM module into the slot.

Figure 5-4. DIMM Installation

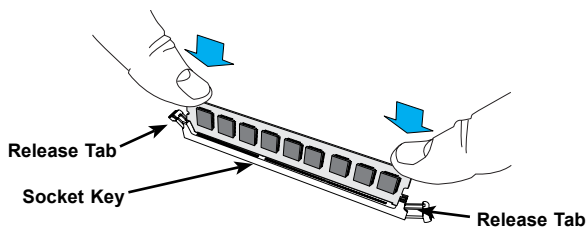

**Note:** see layout diagrams on following page, which display the order of populating DIMMs.

### Processor & Memory Module Population Configuration

For the memory to work properly, follow the tables below for correct installation.

Processors and their Corresponding Memory Modules								
CPU#	Corresponding DIMM Modules							
CPU 1	P1-DIMMA1	P1-DIMMB1	P1-DIMMC1	P1-DIMMD1	P1-DIMMA2	P1-DIMMB2	P1-DIMMC2	P1-DIMMD2
CPU2	P2-DIMME1	P2-DIMMF1	P2-DIMMG1	P2-DIMMH1	P2-DIMME2	P2-DIMMF2	P2-DIMMG2	P2-DIMMH2

Processor and Memory Module Population for Optimal Performance	
Number of CPUs+DIMMs	CPU and Memory Population Configuration Table (For memory to work properly, please follow this table.)
1 CPU & 2 DIMMs	CPU1 P1-DIMMA1/P1-DIMMB1
1 CPU & 4 DIMMs	CPU1 P1-DIMMA1/P1-DIMMB1, P1-DIMMC1/P1-DIMMD1
1 CPU & 6 or 8 DIMMs	CPU1 P1-DIMMA1/P1-DIMMB1, P1-DIMMC1/P1-DIMMD1 + any pair of P1-DIMMA2/P1-DIMMB2/P1-DIMMC2/P1-DIMMD2 slots
2 CPUs & 4 DIMMs	CPU1 + CPU2 P1-DIMMA1/P1-DIMMB1, P2-DIMME1/P2-DIMMF1
2 CPUs & 6 DIMMs	CPU1 + CPU2 P1-DIMMA1/P1-DIMMB1/P1-DIMMC1/P1-DIMMD1, P2-DIMME1/P2-DIMMF1
2 CPUs & 8 DIMMs	CPU1 + CPU2 P1-DIMMA1/P1-DIMMB1/P1-DIMMC1/P1-DIMMD1, P2-DIMME1/P2-DIMMF1/P2-DIMMG1/P2-DIMMH1
2 CPUs & 10~16 DIMMs	CPU1/CPU2 P1-DIMMA1/P1-DIMMB1/P1-DIMMC1/P1-DIMMD1, P2-DIMME1/P2-DIMMF1/P2-DIMMG1/P2-DIMMH1 + any pair of P1, P2 DIMM slots
2 CPUs & 16 DIMMs	CPU1/CPU2 P1-DIMMA1/P1-DIMMB1/P1-DIMMC1/P1-DIMMD1, P2-DIMME1/P2-DIMMF1/P2-DIMMG1/P2-DIMMH1, P1-DIMMA2/P1-DIMMB2/P1-DIMMC2/P1-DIMMD2, P2-DIMME2/P2-DIMMF2/P2-DIMMG2/P2-DIMMH2

Populating RDIMM/LRDIMM DDR4 Memory Modules							
Type	Ranks Per DIMM and Data Width	DIMM Capacity (GB)		Speed (MT/s); Voltage (V); Slots per Channel (SPC) and DIMMs per Channel (DPC)			
				2 Slots per Channel			
				1 DPC		2 DPC	
				E5-2600 V3	E5-2600 V4	E5-2600 V3	E5-2600 V4
		4 Gb	8 Gb	1.2 V	1.2 V	1.2 V	1.2 V
RDIMM	SRx4	8 GB	16 GB	2133	2400	1866	2133
RDIMM	SRx8	4 GB	8 GB	2133	2400	1866	2133
RDIMM	DRx8	8 GB	16 GB	2133	2400	1866	2133
RDIMM	DRx4	16 GB	32 GB	2133	2400	1866	2133
LRDIMM	QRx4	32 GB	64 GB	2133	2400	2133	2400
LRDIMM 3DS	8Rx4	64 GB	128 GB	2133	2400	2133	2400

1 CPU, 2 DIMMs

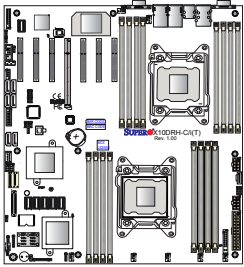

1 CPU, 4 DIMMs

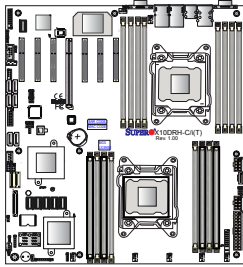

1 CPU, 6 or 8 DIMMs

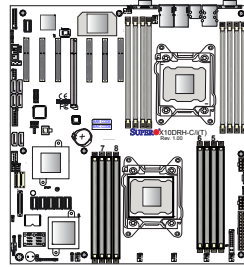

2 CPUs, 4 DIMMs

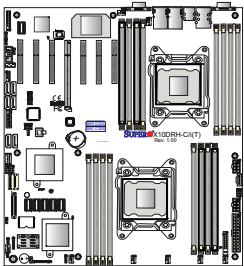

2 CPUs, 6 DIMMs

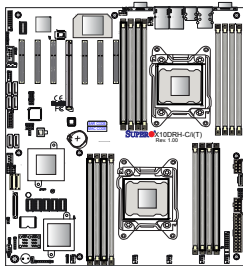

2 CPUs, 8 DIMMs

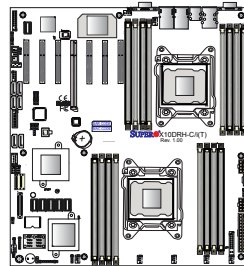

2 CPUs, 10-16 DIMMs

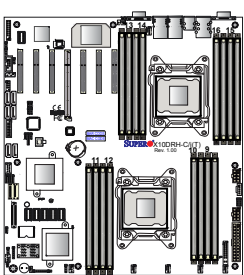

## 5-6 Adding PCI Expansion Cards

The 6048R-E1CR36L can accommodate up to five PCI expansion cards in the PCI expansion slots on the serverboard. Note that two of the slots are already populated with the IT mode disk controller card and the JBOD expansion card.

### Installing an Add-on Card

1. Begin by removing the shield for the PCI slot you wish to populate. Make sure that the card you are installing is supported by the slot (see table below).
2. Fully seat the card into the slot, pushing down with your thumbs evenly on both sides of the card.
3. Finish by using a screw to secure the top of the card shield to the chassis. The PCI slot shields protect the serverboard and its components from EMI and aid in proper ventilation, so make sure there is always a shield covering each unused slot.

Expansion Slot	Description
Slot1 (CPU1)	JBOD Expansion
Slot2 (CPU1)	IT Mode Disk Controller
Slot3 (CPU1)	PCI-Express 3.0 x8 slot from CPU1
Slot4 (CPU2)	PCI-Express 3.0 x16 slot from CPU2
Slot5 (CPU2)	PCI-Express 3.0 x8 slot from CPU2
Slot6 (CPU2)	PCI-Express 3.0 x8 slot from CPU2
Slot7 (CPU2)	PCI-Express 3.0 x8 slot from CPU2

## 5-7 Serverboard Details

Figure 5-5. X10DRH-iT Layout

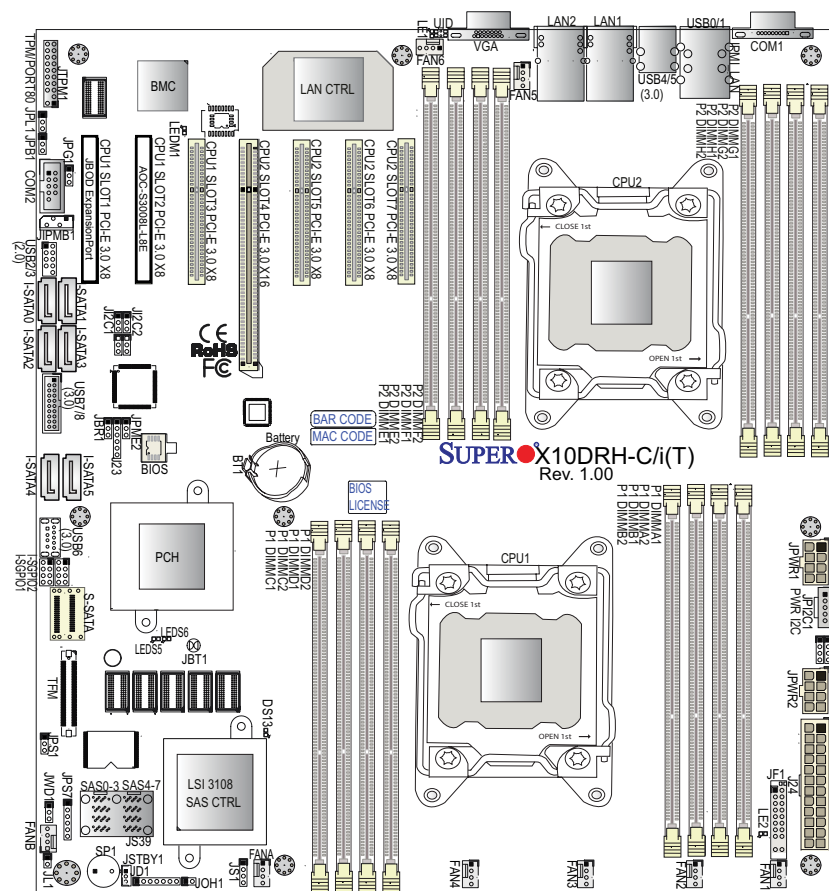

### Notes

Jumpers not indicated are for test purposes only.

Note that the PCI slots are enabled when their corresponding processors are installed. "CPU2 Slot 4" indicates that a second CPU must be installed in the CPU2 socket to enable this PCI slot.

"■" indicates the position of pin 1.

The LSI 3108 onboard controller chip in the layout image above is not populated on the X10DRH-iT.

The 6048R-E1CR36L comes pre-installed with a Hardware RAID controller installed in PCI-E slot 2 and a JBOD expansion port installed in PCI-E slot 1.

## X10DRH-iT Quick Reference

Jumper	Description	Default Setting
JBT1	Clear CMOS/Reset BIOS Configuration	See Section 5-9
J <sup>1</sup> C1/J <sup>1</sup> C2	SMB to PCI-E Slots	Pins 2-3 (Disabled)
JPB1	BMC Enable/Disable	Pins 1-2 (Enabled)
JPG1	VGA Enable/Disable	Pins 1-2 (Enabled)
JPL1	TLAN1/TLAN2 Enable/Disable	Pins 1-2 (Enabled)
JPME2	Manufacture (ME) Mode Select	Pins 1-2 (Normal)
JWD1	Watch Dog Timer	Pins 1-2 (Reset)

Connector	Description
COM1/COM2	Backplane COM Port1/Front accessible COM2 header
FAN1-6, A, B	Fan Headers
J24	24-pin ATX Main Power Connector
JD1	Speaker/Power LED Header
JF1	Front Control Panel Header
JIPMB1	4-pin External BMC I <sup>2</sup> C Header (for an IPMI card)
JL1	Chassis Intrusion Header
J <sup>1</sup> C1	Power Supply SMBbus I <sup>2</sup> C Header
JPWR1/JPWR2	12V 8-pin Power Connectors
JSTBY1	Standby Power Connector
JTPM1	TPM (Trusted Platform Module)/Port 80 Header
LAN1/LAN2	10G-bit Ethernet (TLAN) Ports
IPMI_LAN	Dedicated IPMI LAN (supported by the ASpeed controller)
I-SATA 0-5	SATA 3.0 Ports (supported by Intel PCH)
S-SATA	SATA 3.0 4-port Vertical Connector (supported by Intel SCU)
(I-)SGPIO1/2	Serial Link General Purpose I/O Headers
UID	UID (Unit Identification) Button
USB 0/1 (2.0)	USB 2.0 Ports (rear I/O)
USB 2/3 (2.0)	USB 2.0 Headers
USB 4/5 (3.0)	USB 3.0 Ports (rear I/O)
USB 7/8 (3.0)	USB 3.0 Header
USB 6 (3.0)	Type A USB 3.0 Connector

LED	Description	State	Status
LE1	Rear UID LED	Blue: On	Unit Identified
LE2	Onboard PWR LED	On	Power On
LEDM1	BMC Heartbeat LED	Green: Blinking	BMC Normal

## 5-8 Connector Definitions

### Power Connectors

A 24-pin main power supply connector (J24) and two 8-pin CPU power connectors (JPWR1/JPWR2) must be connected to the power supply to provide adequate power to the system. These power connectors meet the SSI EPS 12V specification. See the table on the right for pin definitions.

ATX Power 24-pin Connector Pin Definitions			
Pin#	Definition	Pin #	Definition
13	+3.3V	1	+3.3V
14	-12V	2	+3.3V
15	COM	3	COM
16	PS_ON	4	+5V
17	COM	5	COM
18	COM	6	+5V
19	COM	7	COM
20	Res (NC)	8	PWR_OK
21	+5V	9	5VSB
22	+5V	10	+12V
23	+5V	11	+12V
24	COM	12	+3.3V

### Secondary Power Connector

JPWR1 and JPWR2 must also be connected to the power supply. See the table on the right for pin definitions.

+12V 8-pin Power Pin Definitions	
Pins	Definition
1 - 4	Ground
5 - 8	+12V

#### Required Connection

**Warning:** To provide adequate power supply to the serverboard, be sure to connect J24 and both JPWR1 and JPWR2 to the power supply. Failure to do so will void the manufacturer warranty on your power supply and serverboard.

### Power Button

The Power On connection is on pins 1 and 2 of JF1. These should be connected to the chassis power button. Momentarily contacting both pins will power on/off the system. To turn off the power when the system is on, press the button for 4 seconds or longer. See the table on the right for pin definitions.

Power Button Pin Definitions (JF1)	
Pin#	Definition
1	Power Signal
2	Ground

### Reset Button

The Reset Button connection is located on pins 3 and 4 of JF1 and attaches to the reset switch on the computer chassis. See the table on the right for pin definitions.

Reset Button Pin Definitions (JF1)	
Pin#	Definition
3	Reset
4	Ground

### Power Fail LED

The Power Fail LED connection is located on pins 5 and 6 of JF1. Refer to the table on the right for pin definitions.

PWR Fail LED Pin Definitions (JF1)	
Pin#	Definition
5	3.3V
6	PWR Supply Fail

### Overheat, Fan/Power Fail/UID LED

Connect an LED cable to pins 7 and 8 of the front control panel to use the Overheat/Fan Fail/Power Fail and UID LED connections. The red LED on pin 8 provides warnings of overheat, fan failure or power failure. The blue LED on pin 7 works as the front panel UID LED indicator. Refer to the table on the right for pin definitions.

OH/Fan Fail/ PWR Fail/Blue_UID LED Pin Definitions (JF1)	
Pin#	Definition
7	Blue_UID LED
8	OH/Fan Fail/Power Fail

OH/Fan Fail/PWR Fail LED Status (Red LED)	
State	Definition
Off	Normal
On	Overheat
Flashing	Fan Fail

### NIC2 (LAN2) LED

The LED connections for LAN2 are on pins 9 and 10 of JF1. Attach an LED cable to display network activity. See the table on the right for pin definitions.

NIC2 LED Pin Definitions (JF1)	
Pin#	Definition
9	Activity
10	Link

### NIC1 (LAN1) LED

The LED connections for LAN1 are on pins 11 and 12 of JF1. Attach an LED cable to display network activity. See the table on the right for pin definitions.

NIC1 LED Pin Definitions (JF1)	
Pin#	Definition
11	Activity
12	Link

### HDD LED/UID Switch

The HDD LED connection is located on pins 13 and 14 of JF1. Attach a cable to pin 14 to show HDD activity status. Attach a cable to pin 13 to use UID switch. See the table on the right for pin definitions.

HDD LED Pin Definitions (JF1)	
Pin#	Definition
13	UID Switch
14	HD Active

### Power On LED

The Power On LED connector is located on pins 15 and 16 of JF1 (use JLED for a 3-pin connector). This connection is used to provide LED indication of power being supplied to the system. See the table on the right for pin definitions.

Power LED Pin Definitions (JF1)	
Pin#	Definition
15	3.3V
16	PWR LED

### NMI Button

The non-maskable interrupt button header is located on pins 19 and 20 of JF1. Refer to the table on the right for pin definitions.

NMI Button Pin Definitions (JF1)	
Pin#	Definition
19	Control
20	Ground

### Fan Headers

There are eight fan headers on the serverboard, all of which are 4-pin headers. Pins 1-3 are backward compatible with the traditional 3-pin fans. (Fan speed control is supported with 4-pin fans only.) See the table on the right for pin definitions. The onboard fan speeds are controlled by Thermal Management (via IPMI).

Fan Header Pin Definitions (FAN1-6, FAN A, FAN B)	
Pin#	Definition
1	Ground (Black)
2	+12V (Red)
3	Tachometer
4	PWR Modulation

### Chassis Intrusion

The Chassis Intrusion header is designated JL1. Attach an appropriate cable from the chassis to inform you of a chassis intrusion when the chassis is opened

Chassis Intrusion Pin Definitions	
Pin#	Definition
1	Intrusion Input
2	Ground

### Internal Speaker

The internal speaker, located at SP1, can be used to provide audible indications for various beep codes. See the table on the right for pin definitions..

Internal Buzzer (SP1) Pin Definition		
Pin#	Definitions	
Pin 1	Pos. (+)	Beep In
Pin 2	Neg. (-)	Alarm Speaker

### Power LED/Speaker

On the JD1 header, pins 1-3 are for a power LED and pins 4-7 are for the speaker. Close pins 4-7 with a jumper to use an external speaker. If you wish to use the onboard speaker, please close pins 6-7. See the table on the right for speaker pin definitions.

PWR LED Connector Pin Definitions	
Pin Setting	Definition
Pin 1	JD1_PIN1
Pin 2	FP_PWR_LED
Pin 3	FP_PWR_LED

Speaker Connector Pin Settings	
Pin Setting	Definition
Pin 4	P5V
Pin 5	Key
Pin 6	R_SPKPIN_N
Pin 7	R_SPKPIN

### SGPIO Headers

The SGPIO (Serial General Purpose Input/Output) headers are used to communicate with the enclosure management chip on the backplane. T-SGPIO1/2 support the I-SATA ports and S-SGPIO1 supports the S-SATA ports. See the table on the right for pin definitions.

SGPIO Header Pin Definitions			
Pin#	Definition	Pin	Definition
1	NC	2	NC
3	Ground	4	DATA Out
5	Load	6	Ground
7	Clock	8	NC

NC = No Connection

### Power Supply SMBus I<sup>2</sup>C Header

The power System Management Bus header at JPI<sup>2</sup>C1 is used to monitor the status of the power supply, fan and system temperature. See the table on the right for pin definitions.

PWR SMBus Header Pin Definitions	
Pin#	Definition
1	Clock
2	Data
3	PWR Fail
4	Ground
5	+3.3V

**Universal Serial Bus (USB)**

Two USB 3.0 and two USB 2.0 ports are located on the rear I/O panel. In addition, two USB 3.0 headers are provided on the serverboard for three front accessible USB 3.0 connections (USB6, USB 7/8). A USB 2.0 header is also located on the serverboard to provide two USB 2.0 connections (USB 2/3) for front access(cables not included). See the tables on the right for pin definitions.

Back Panel USB 0/1 (2.0) Pin Definitions			
Pin#	Definition	Pin#	Definition
1	+5V	5	+5V
2	USB_PN1	6	USB_PN0
3	USB_PP1	7	USB_PP0
4	Ground	8	Ground

Front Panel USB 2/3 (2.0) Pin Definitions			
Pin #	Definition	Pin #	Definition
1	+5V	2	+5V
3	USB_PN2	4	USB_PN3
5	USB_PP2	6	USB_PP3
7	Ground	8	Ground
9	Key	10	Ground

Back Panel USB 4/5 (3.0), Front Panel USB 7/8 (3.0), Type A USB 6 (3.0) Pin Definitions	
Pin#	Description
1	VBUS
2	SSRX-
3	SSRX+
4	Ground
5	SSTX-
6	SSTX+
7	GND_DRAIN
8	D-
9	D+

**IPMB**

A System Management Bus header for IPMI 2.0 is located at JIPMB1. Connect the appropriate cable here to use the IPMB I<sup>2</sup>C connection on your system.

IPMB Header Pin Definitions	
Pin#	Definition
1	Data
2	Ground
3	Clock
4	No Connection

**DOM Power Connectors**

Two power connectors for SATA DOM (Disk On Module) devices are located at JSD1/JSD2. Connect appropriate cables here to provide power support for your DOM devices.

DOM PWR Pin Definitions	
Pin#	Definition
1	+5V
2	Ground
3	Ground

**Standby Power Header**

The +5V Standby Power header is located at JSTBY1. See the table on the right for pin definitions. (You must also have a card with a Standby Power connector and a cable to use this feature.)

Standby PWR Pin Definitions	
Pin#	Definition
1	+5V Standby
2	Ground
3	No Connection

**Unit Identifier Switch**

The rear UID button and LED are located next to the VGA port. The front UID LED is located next to the UID switch. The front UID switch is located on pin 13 on JF1 and the front UID LED is located on pin 7 on JF1. When you press the front or rear UID switch, both front and rear UID LEDs will be turned on. Press the UID switch again to turn off the LED indicators. These indicators provide easy identification of a system unit that may be in need of service.

UID Switch	
Pin#	Definition
1	Ground
2	Ground
3	Button In
4	Button In

UID LED Status	
Color/State	Status
Blue: On	Unit Identified

**Note:** UID can also be triggered via IPMI. For more information on IPMI, please refer to the IPMI User's Guide posted on our website at <http://www.supermicro.com>.

**TPM Header/Port 80**

A Trusted Platform Module/Port 80 header is located at JTPM1 to provide TPM support and a Port 80 connection. Use this header to enhance system performance and data security. See the table on the right for pin definitions.

TPM/Port 80 Header Pin Definitions			
Pin #	Definition	Pin #	Definition
1	LCLK	2	GND
3	LFRAME#	4	<(KEY)>
5	LRESET#	6	+5V (X)
7	LAD 3	8	LAD 2
9	+3.3V	10	LAD1
11	LAD0	12	GND
13	SMB_CLK4	14	SMB_DAT4
15	+3V_DUAL	16	SERIRQ
17	GND	18	CLKRUN# (X)
19	LPCPD#	20	LDRQ# (X)

**Serial Ports**

Two serial ports are included on the serverboard. COM1 is a rear I/O port and COM2 is a header located near PCI-E slot 1, which may be used front front access..

**Ethernet Ports**

Two 10Gb Ethernet (LAN) ports are located on the I/O backplane. A dedicated IPMI LAN port is also included. These ports accept RJ45 type cables.

**5-9 Jumper Settings****Explanation of Jumpers**

To modify the operation of the serverboard, jumpers can be used to choose between optional settings. Jumpers create shorts between two pins to change the function of the connector. Pin 1 is identified with a square solder pad on the printed circuit board. See the serverboard layout pages for jumper locations.

**Note:** On a two-pin jumper, "Closed" means the jumper is on both pins and "Open" means the jumper is either on only one pin or completely removed.

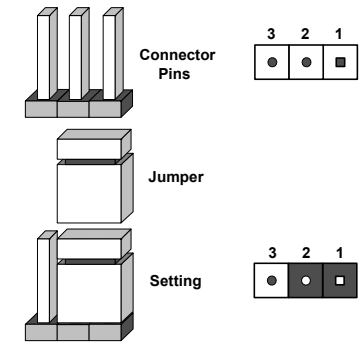
**CMOS Clear**

JBT1 is used to clear CMOS (which will also clear any passwords). Instead of pins, this jumper consists of contact pads to prevent accidentally clearing the contents of CMOS.

**To clear CMOS,**

1. First power down the system and unplug the power cord(s).
2. With the power disconnected, short the CMOS pads with a metal object such as a small screwdriver.
3. Remove the screwdriver (or shorting device).
4. Reconnect the power cord(s) and power on the system.

**Note:** Do not use the PW\_ON connector to clear CMOS.

**VGA Enable/Disable**

JPG1 allows you to enable or disable the VGA port. The default position is on pins 1 and 2 to enable VGA. See the table on the right for jumper settings.

VGA Enable/Disable Jumper Settings	
Jumper Setting	Definition
Pins 1-2	Enabled
Pins 2-3	Disabled

### LAN Enable/Disable

JPL1 enables or disables the Gb LAN ports on the serverboard. See the table on the right for jumper settings. The default setting is Enabled.

GLAN Enable Jumper Settings	
Jumper Setting	Definition
Pins 1-2	Enabled
Pins 2-3	Disabled

### I<sup>2</sup>C Bus to PCI-Exp. Slots

Jumpers JI<sup>2</sup>C1 and JI<sup>2</sup>C2 allow you to connect the System Management Bus (I<sup>2</sup>C) to the PCI-Express slots to improve PCI performance. The default setting is Enabled. Both jumpers must be set to the same setting. See the table on the right for jumper settings.

I <sup>2</sup> C to PCI-E Slots Jumper Settings	
Jumper Setting	Definition
Pins 1-2	Enabled
Pins 2-3	Disabled

### Manufacturer's Mode

Jumper JPME2 allows the user to flash the system firmware from a host server in order to modify system settings. Close this jumper to bypass SPI flash security, and force ME into recovery mode in order to use recovery jumpers. See the table on the right for jumper settings.

ME Mode Select Jumper Settings	
Jumper Setting	Definition
Pins 1-2	Normal
Pins 2-3	Manufacture's Mode

### BMC Enable

Jumper JPB1 allows you to enable the embedded the ASpeed AST 2400 BMC (Baseboard Management) Controller to provide IPMI 2.0/KVM support on the serverboard. The default setting is Enabled. See the table on the right for jumper settings.

BMC Enable Jumper Settings	
Jumper Setting	Definition
Pins 1-2	Enabled
Pins 2-3	Disabled

### Watch Dog Enable/Disable

Jumper JWD1 controls the Watch Dog function. Watch Dog is a system monitor that can reboot the system when a software application hangs. Jumping pins 1-2 will cause WD to reset the system if an application hangs. Jumping pins 2-3 will generate a non-maskable interrupt signal for the application that hangs. See the table on the right for jumper settings. Watch Dog must also be enabled in BIOS.

Watch Dog Jumper Settings	
Jumper Setting	Definition
Pins 1-2	Reset
Pins 2-3	NMI
Open	Disabled

**Note:** When enabled, the user needs to write their own application software in order to disable the Watch Dog Timer.

## 5-10 Onboard Indicators

### LAN LEDs

The Ethernet ports (located beside the VGA port) have two LEDs. On each port, the green LED flashes to indicate activity while the other LED may be green, amber or off to indicate the speed of the connection. See the table on the right for the functions associated with the connection speed LED.

LAN1/2 LED (Connection Speed Indicator)	
LED Color	Definition
Off	No connection, 10 or 100 Mbps
Green	10 Gbps
Amber	1 Gbps

### Dedicated IPMI LAN LEDs

A dedicated IPMI LAN is also located on the I/O backplane. The amber LED on the right indicates activity, while the green LED on the left indicates the speed of the connection. See the table at right for more information.

IPMI LAN Link LED (Left) & Activity LED (Right)		
	Color/State	Definition
Link (Left)	Green: Solid	100 Mbps
	Amber: Solid	1 Gbps
Activity (Right)	Amber: Blinking	Active

### Onboard Power LED

An Onboard Power LED is located at LE2. This LED Indicator is lit when the system is on. Be sure to unplug the power cable before removing or adding any components. See the table on the right for more details.

Onboard PWR LED Indicator LED States	
Color/State	Definition
Off	System Power Off
Green: On	System Power On

### BMC Heartbeat LED

A BMC Heartbeat LED is located at LEDM1 on the serverboard. When blinking, the BMC is functioning normally.

BMC Heartbeat LED States	
Color/State	Definition
Green: Blinking	BMC Normal

## 5-11 SATA Ports

### SATA Ports

There are ten SATA 3.0 ports included on the serverboard. Six ports (I-SATA 0-5) are supported by the Intel PCH C612 while the other four are supported by the Intel SCU and are located on a vertical S-SATA connector.

**Note:** For more information on SATA HostRAID configuration, please refer to the Intel SATA HostRAID User's Guide posted on our website at <http://www.supermicro.com>.

## 5-12 Installing Software

The Supermicro FTP site contains drivers and utilities for your system at <ftp://ftp.supermicro.com>. Some of these must be installed, such as the chipset driver.

After accessing the FTP site, go into the CDR\_Images directory and locate the ISO file for your serverboard. Download this file to create a CD/DVD of the drivers and utilities it contains. (You may also use a utility to extract the ISO file if preferred.)

Another option is to go to the Supermicro website at <http://www.supermicro.com/products/>. Find the product page for your serverboard here, where you may download individual drivers and utilities.

After creating a CD/DVD with the ISO files, insert the disk into the CD/DVD drive on your system and the display shown in Figure 5-6 should appear.



Figure 5-6. Driver/Tool Installation Display Screen

**Note:** Click the icons showing a hand writing on paper to view the readme files for each item. Click the computer icons to the right of these items to install each item (from top to the bottom) one at a time. **After installing each item, you must re-boot the system before moving on to the next item on the list.** The bottom icon with a CD on it allows you to view the entire contents.

## SuperDoctor® 5

The Supermicro SuperDoctor 5 is a program that functions in a command-line or web-based interface in Windows and Linux operating systems. The program monitors system health information such as CPU temperature, system voltages, system power consumption, fan speed, and provides alerts via email or Simple Network Management Protocol (SNMP).

SuperDoctor 5 comes in local and remote management versions and can be used with Nagios to maximize your system monitoring needs. With SuperDoctor 5 Management Server (SSM Server), you can remotely control power on/off and reset chassis intrusion for multiple systems with SuperDoctor 5 or IPMI. SD5 Management Server monitors HTTP, FTP, and SMTP services to optimize the efficiency of your operation.

**Note:** The default User Name and Password for SuperDoctor 5 is admin / admin.

Figure 5-7. SuperDoctor 5 Interface Display Screen (Health Information)



**Note:** The SuperDoctor 5 program and User's Manual can be downloaded from the Supermicro web site at [http://www.supermicro.com/products/info/sms\\_sd5.cfm](http://www.supermicro.com/products/info/sms_sd5.cfm).

## 5-13 Onboard Battery

Care must be taken to assure that the chassis cover is in place when the system is operating to assure proper cooling. Out of warranty damage to the system can occur if this practice is not strictly followed.

**Figure 5-8. Installing the Onboard Battery**

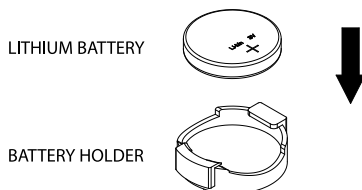

Please handle used batteries carefully. Do not damage the battery in any way; a damaged battery may release hazardous materials into the environment. Do not discard a used battery in the garbage or a public landfill. Please comply with the regulations set up by your local hazardous waste management agency to dispose of your used battery properly.

## Chapter 6

### Advanced Chassis Setup

This chapter covers the steps required to install components and perform maintenance on the SC847BE1C-R1K28LPB chassis. For component installation, follow the steps in the order given to eliminate the most common problems encountered. If some steps are unnecessary, skip ahead to the step that follows.

**Tools Required:** The only tool you will need to install components and perform maintenance is a Philips screwdriver.

#### 6-1 Static-Sensitive Devices

Electrostatic discharge (ESD) can damage electronic components. To prevent damage to any printed circuit boards (PCBs), it is important to handle them very carefully. The following measures are generally sufficient to protect your equipment from ESD damage.

##### Precautions

- Use a grounded wrist strap designed to prevent static discharge.
- Touch a grounded metal object before removing any board from its antistatic bag.
- Handle a board by its edges only; do not touch its components, peripheral chips, memory modules or gold contacts.
- When handling chips or modules, avoid touching their pins.
- Put the serverboard, add-on cards and peripherals back into their antistatic bags when not in use.
- For grounding purposes, make sure your computer chassis provides excellent conductivity between the power supply, the case, the mounting fasteners and the serverboard.

Figure 6-1. Front and Rear Chassis Views

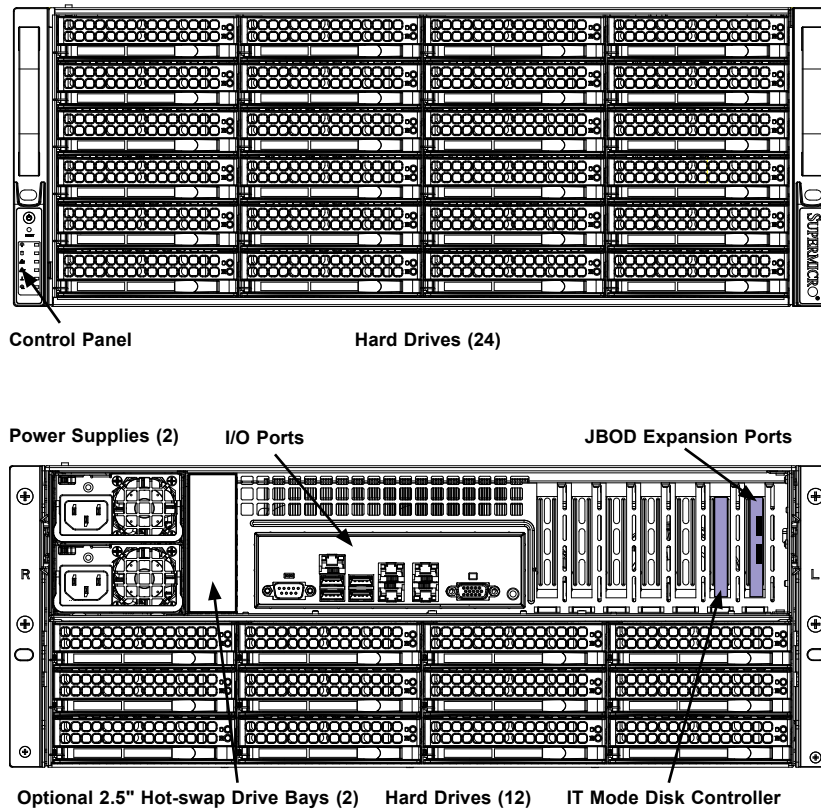

## 6-2 Control Panel

The control panel (located on the front of the chassis) must be connected to the JF1 connector on the serverboard to provide you with system status indications. A ribbon cable has bundled these wires together to simplify the connection. Connect the cable from JF1 on the serverboard to the Control Panel PCB (printed circuit board). Make sure the red wire plugs into pin 1 on both connectors. Pull all excess cabling out of the airflow path.

The LEDs inform you of system status. See Chapter 3 for details on the LEDs and the control panel buttons. Details on JF1 can be found in Chapter 5.

## 6-3 Removing the Chassis Cover

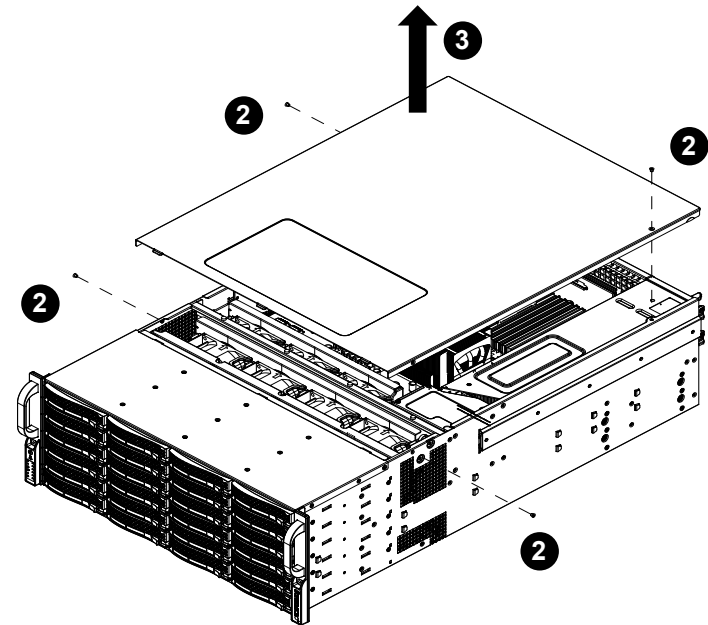

Figure 6-2. Removing the Chassis Cover

### Removing the Chassis Cover

1. Unplug the chassis from any power source
2. Remove the screws securing the cover to the chassis.
3. Lift the cover up and off the chassis.

**Warning:** Except for short periods of time, do NOT operate the server without the chassis cover in place. The cover must be in place to allow proper airflow and prevent overheating.

## 6-4 System Fans

Seven 8-cm hot-swap chassis fans provide redundant cooling for the 6048R-E1CR36L. It is very important that the chassis top cover is properly installed and making a good seal in order for the cooling air to circulate properly through the chassis and cool the components. See Figure 6-3.

### System Fan Failure

Fan speed is controlled by system temperature via IPMI. If a fan fails, the remaining fans will ramp up to full speed and the overheat/fan fail LED on the control panel will turn on.

Replace any failed fan at your earliest convenience with the same type and model (the system can continue to run with a failed fan). Remove the top chassis cover while the system is still running to determine which of the fans has failed.

### Replacing System Fans

#### Removing a Fan

1. Remove the top chassis cover while the system is still running to determine which of the fans has failed.
2. Depress the tab on the side of the fan to unlock and remove the fan along with its housing. The fan's power connections will automatically detach.
3. System power does not need to be shut down since the fans are hot-pluggable.
4. Replace the failed fan with an identical 8-cm, 12 volt fan (available from Supermicro).
5. Position the new fan into the space vacated by the failed fan previously removed. A "click" can be heard when the fan is fully installed in place and the power connections are made.
6. If the system power is on, the hot-plug feature will cause the fan to start immediately upon being connected to its header on the serverboard.

Figure 6-3. Replacing System Cooling Fans

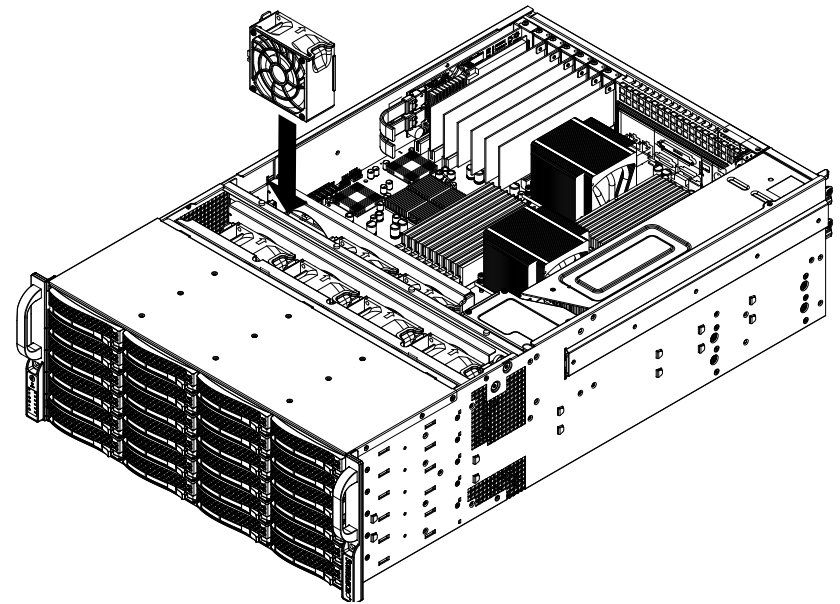

## 6-5 Drive Bay Installation/Removal

### Accessing the Drive Bays

**SAS/SATA Drives:** You do not need to access the inside of the chassis or remove power to replace or swap SATA drives. Proceed to the next step for instructions.

**Note:** Use caution when working around the backplane. Do not touch the backplane with any metal objects and make sure no ribbon cables touch the backplane or obstruct the holes, which aid in proper airflow.

## Hard Drive Installation

### Mounting a Hard Drive in a Drive Carrier

The SAS/SATA drives are mounted in drive carriers to simplify their installation and removal from the chassis. These carriers also help promote proper airflow for the drives. For this reason, even empty carriers without drives installed must remain in the chassis.

To add a new hard drive, install a drive into the carrier with the printed circuit board side facing down so that the mounting holes align with those in the carrier. Secure the drive to the carrier with four screws, as shown in Figure 6-4.

### Installing/Removing Hard Drives

1. To remove a drive carrier, first push the release button located beside the drive's LEDs.
2. Swing the handle fully out and use it to pull the drive carrier straight out.

### Installing a Hard Drive to the Hard Drive Tray

1. Remove the two screws securing the dummy drive to the drive tray and remove the dummy drive. Place the hard drive tray on a flat surface such as a desk, table or work bench (see Figure 6-4).
2. Slide the hard drive into the tray with the printed circuit board side facing down.
3. Carefully align the mounting holes in both the drive tray and the hard drive.
4. Secure the hard drive to the tray using six screws.
5. Replace the drive tray into the chassis. Make sure to close the drive tray handle to lock the drive tray into place (see Figure 6-5)..

**Warning:** Enterprise level hard disk drives are recommended for use in Supermicro chassis and servers. For information on recommended HDDs, visit the Supermicro website at <http://www.supermicro.com/products/info/storage.cfm>

**Warning:** Regardless of how many hard drives are installed, all drive carriers must remain in the drive bays to maintain proper airflow.

Figure 6-4. Mounting a Drive in a Carrier

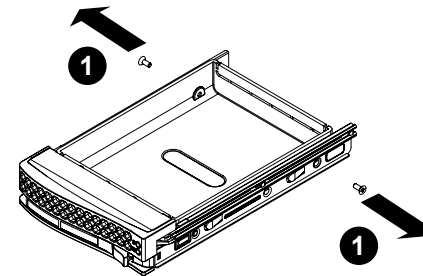
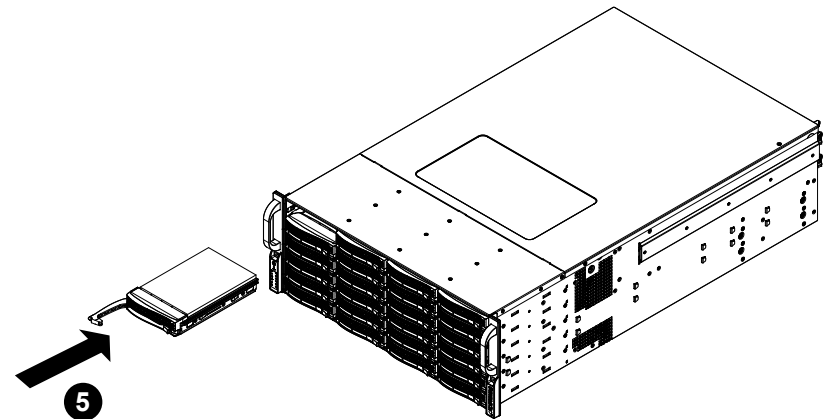

Figure 6-5. Installing a Drive Carrier



### Hard Drive Backplane

The hard drives plug into a backplane that provides power, drive ID and bus termination. The supplied RAID controller provides hot-swap capability with SAS/SATA drive state indication. The backplane is already preconfigured, so there are no jumpers or switches present on it.

## Removing the Air Shroud

Under most circumstances you will not need to remove the air shroud to perform any service on the system. However, if you need to temporarily remove it (the air shroud should always be in place when the system is operating), please follow this procedure.

Air shrouds concentrate airflow to maximize fan efficiency. The SC847 chassis air shroud does not require screws to set up

### Installing the Air Shroud

1. Confirm that your air shroud matches your chassis model.
2. Place air shroud in the chassis. The air shroud fits behind the two fans closest to the power supply.

Figure 6-6. Removing the Air Shroud

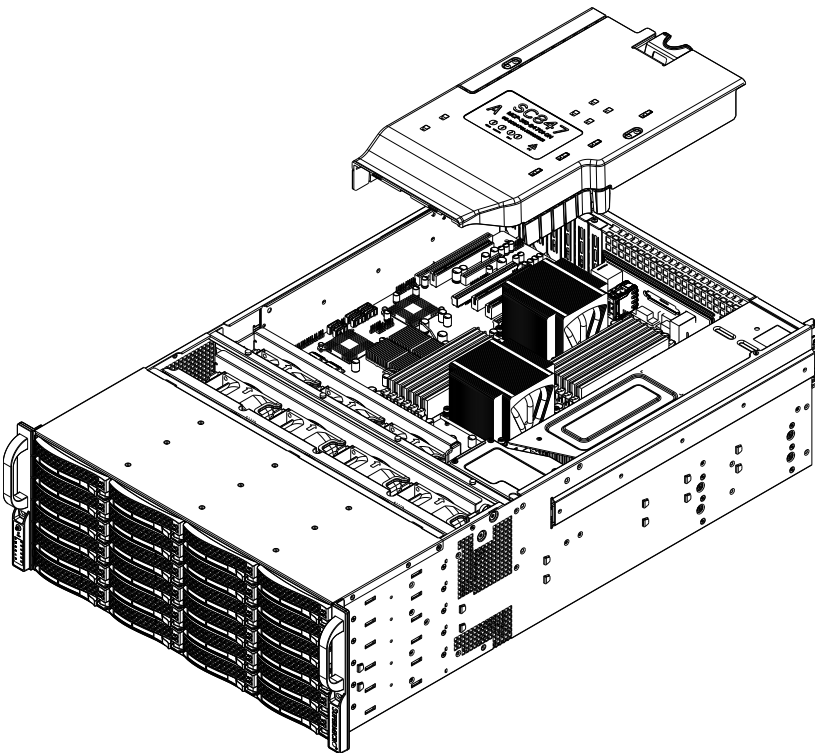

## 6-6 Installing Optional Fixed Hard Drives

Optional brackets for the SC847 chassis may be used to install either one 3.5" fixed hard drive or two 2.5" fixed hard drives. These brackets install under the serverboard tray. Each chassis can accommodate up to two of these brackets to support up to two 3.5" hard drives or up to four 2.5" hard drives (tray p/n: MCP-220-84701-0N).

Figure 6-7. Installing Optional Fixed Hard drives

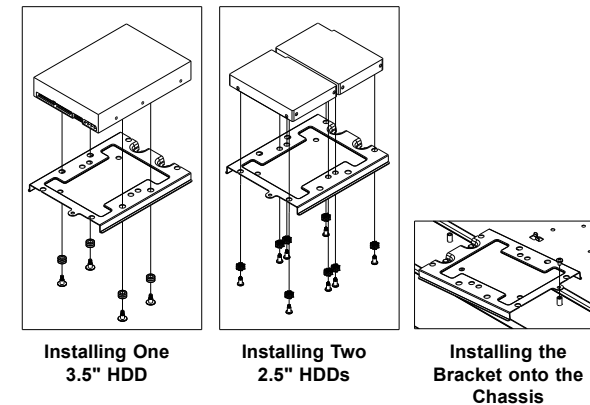

### Installing a 3.5" Hard Drive into the Bracket

1. Align the four washers and screws with the holes in the hard drive and the holes in the bracket.
2. Secure the hard drive to the bracket using the screws and washers provided.
3. See the instructions below for Installing the bracket onto the chassis.

### Installing Two 2.5" Hard Drives into the Bracket

1. Align the eight external tooth washers and eight screws with the holes in the hard drive and the holes in the bracket.
2. Secure the hard drive to the bracket using the screws and washers provided.
3. See the instructions below for Installing the bracket onto the chassis.

### Installing the Bracket onto the Chassis

1. Align the holes in the bracket with the chassis standoffs.
2. Secure the bracket using the screw provided.

## 6-7 Power Supply

The 6048R-E1CR36L has an 1280 watt redundant, hot-plug power supply consisting of two power modules. Each power supply module has an auto-switching capability, which enables it to automatically sense and operate at a 100V - 240V input voltage.

### Power Supply Failure

If either of the two power supply modules fail, the other will take the full load and allow the system to continue operation without interruption. The Power Fail LED will illuminate and remain on until the failed module has been replaced. Replacements can be ordered directly from Supermicro (see contact information in the Preface). The power supply modules have a hot-swap capability, meaning you can replace the failed module without powering down the system.

#### Removing/Replacing the Power Supply

1. First unplug the power cord from the failed power supply module.
2. Push the release tab on the back of the power supply as illustrated
3. Pull the power supply out using the handle provided.
4. Replace the failed power module with another of the same model.
5. Push the new power supply module into the power bay until it clicks into the locked position.
6. Plug the AC power cord back into the module.

Figure 6-8. Replacing a Power Supply Module

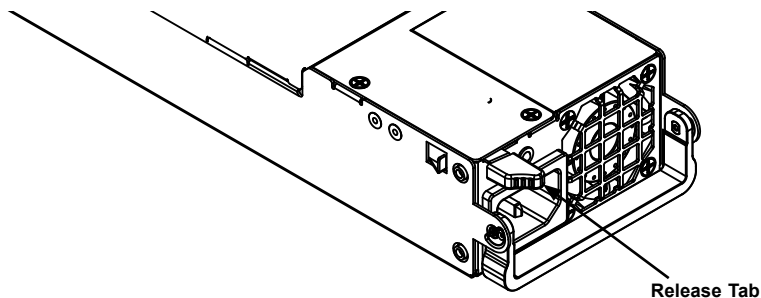

## DC Power

The AC power supplies may be removed and replaced with a DC power supply.

#### Replacing the AC Power Supply with a DC Power Supply

1. Shut down the system and unplug the AC power cord.
2. Remove the AC power supply as described in the procedure above.
3. Install the DC power supply into the empty power bay.
4. Connect the wires from the power plug to the connections on the rear of the power supply as follows: connect return bus to RTN connector, connect negative source voltage to -48V connector. **Note:** wires must be 10 AWG. The ground screw beside the connectors may be used to provide an earth ground for the server system.

Please keep in mind the following when adding a DC power supply:

- This equipment shall be installed in accordance with the National Electrical Code (NEC) in the United States, or the Canadian Electrical Code (CEC) in Canada, or the applicable local codes and regulations.
- This equipment shall be provided with a readily accessible disconnect device in the building installation supply wiring.
- This equipment shall be provided with a suitably rated Listed DC circuit breaker or Listed DC fuse in the building installation supply wiring.
- This equipment is to be Installed Only in Restricted Access Areas (Dedicated Equipment Rooms, Electrical Closets, or the like).
- This equipment shall be connected to earth ground with minimum 10 AWG supply grounding conductor(s), which shall be terminated on the equipment grounding studs using Listed wire connector devices that are suitably sized and rated for the application.
- The marked electrical ratings on this equipment, -48 to -60 Vdc, include the manufacturer's specified tolerances on the supply voltage.

## 6-8 Attaching a JBOD Expansion Chassis

The 6048R-E1CR36L features dual JBOD expansion ports. The figure below illustrates the recommended expansion strategy. The JBOD attachment will vary depending on the specific JBOD chassis that is being connected. Please follow the instructions provided with the JBOD.

Figure 6-9. JBOD Expansion Port

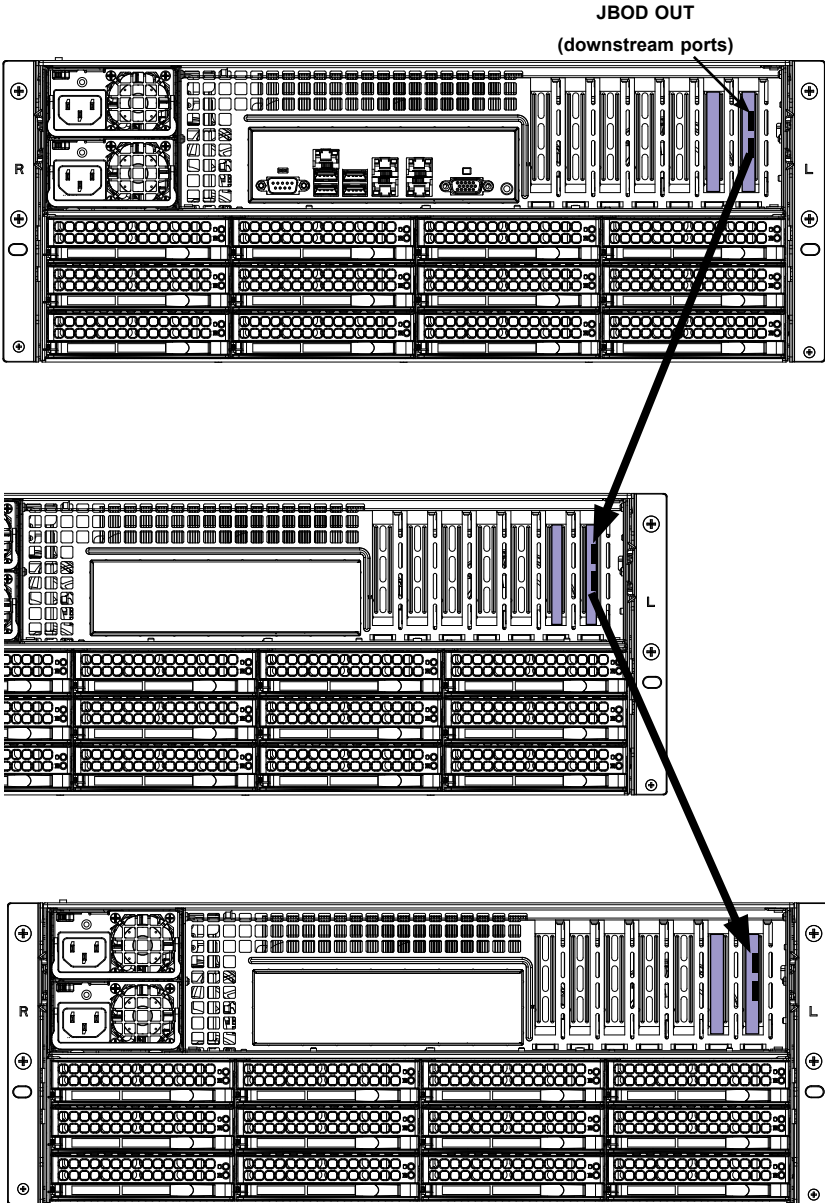

**Note:** the use of two cables (8x SAS lanes) is recommended.

## Chapter 7

# BIOS

### 7-1 Introduction

This chapter describes the AMI BIOS setup utility for the X10DRH-C/CT/i/iT. The ROM BIOS is stored in a Flash EEPROM and can be easily updated. This chapter describes the basic navigation of the AMI BIOS setup utility screens.

#### Starting BIOS Setup Utility

To enter the AMI BIOS setup utility screens, press the <Delete> key while the system is booting up.

**Note:** In most cases, the <Delete> key is used to invoke the AMI BIOS setup screen.

Each main BIOS menu option is described in this manual. The AMI BIOS setup menu screen has two main frames. The left frame displays all the options that can be configured. Grayed-out options cannot be configured. Options in blue can be configured by the user. The right frame displays the key legend. Above the key legend is an area reserved for a text message. When an option is selected in the left frame, it is highlighted in white. Often a text message will accompany it.

**Note:** the AMI BIOS has default text messages built in. Supermicro retains the option to include, omit, or change any of these text messages.

The AMI BIOS setup utility uses a key-based navigation system called "hot keys." Most of the AMI BIOS setup utility "hot keys" can be used at any time during the setup navigation process. These keys include <F1>, <F4>, <Enter>, <Esc>, arrow keys, etc.

**Note:** Options printed in **Bold** are default settings.

#### How To Change the Configuration Data

The configuration data that determines the system parameters may be changed by entering the AMI BIOS setup utility. This setup utility can be accessed by pressing <Del> at the appropriate time during system boot.

## How to Start the Setup Utility

Normally, the only visible Power-On Self-Test (POST) routine is the memory test. As the memory is being tested, press the <Delete> key to enter the main menu of the AMI BIOS setup utility. From the main menu, you can access the other setup screens. An AMI BIOS identification string is displayed at the left bottom corner of the screen, below the copyright message.

**Warning:** Do not upgrade the BIOS unless your system has a BIOS-related issue. Flashing the wrong BIOS can cause irreparable damage to the system. In no event shall Supermicro be liable for direct, indirect, special, incidental, or consequential damages arising from a BIOS update. If you have to update the BIOS, do not shut down or reset the system while the BIOS is updating to avoid possible boot failure.

## 7-2 Main Setup

When you first enter the AMI BIOS setup utility, you will enter the Main setup screen. You can always return to the Main setup screen by selecting the Main tab on the top of the screen. The Main BIOS setup screen is shown below.



The following Main menu items will be displayed:

### System Date/System Time

Use this option to change the system date and time. Highlight *System Date* or *System Time* using the arrow keys. Enter new values using the keyboard. Press the <Tab> key or the arrow keys to move between fields. The date must be entered in Day MM/DD/YYYY format. The time is entered in HH:MM:SS format.

**Note:** The time is in the 24-hour format. For example, 5:30 P.M. appears as 17:30:00.

### Supermicro X10DRH-C/i

**Version:** This item displays the version of the BIOS ROM used in the system.

**Build Date:** This item displays the date when the version of the BIOS ROM used in the system was built.

### Memory Information

**Total Memory:** This item displays the total size of memory available in the system.

**Memory Speed:** This item displays the default speed of the memory modules installed in the system.

## 7-3 Advanced Setup Configurations

Use the arrow keys to select Advanced setup and press <Enter> to access the submenu items:

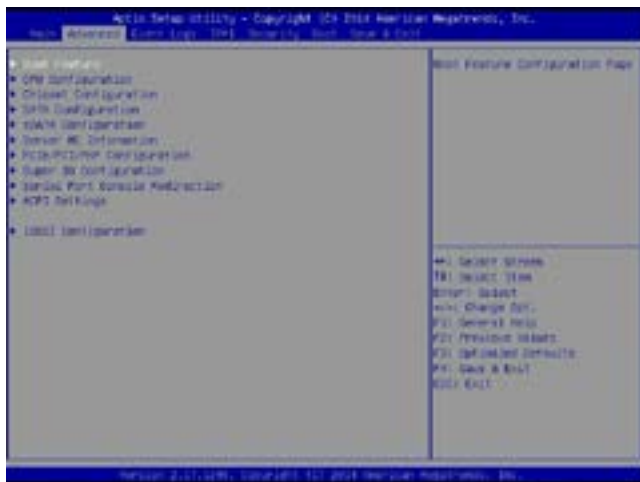

**Warning:** Take Caution when changing the Advanced settings. An incorrect value, a very high DRAM frequency or an incorrect BIOS timing setting may cause the system to malfunction. When this occurs, restore the setting to the manufacture default setting.

### ►Boot Feature

#### Quiet Boot

Use this feature to select the screen display between POST messages or the OEM logo at bootup. Select Disabled to display the POST messages. Select Enabled to display the OEM logo instead of the normal POST messages. The options are **Enabled** and Disabled.

#### AddOn ROM Display Mode

Use this item to set the display mode for the Option ROM. Select Keep Current to use the current AddOn ROM display setting. Select Force BIOS to use the Option ROM display mode set by the system BIOS. The options are **Force BIOS** and Keep Current.

#### Bootup Num-Lock State

Use this item to set the Power-on state for the Numlock key. The options are Off and **On**.

#### Wait For 'F1' If Error

Select Enabled to force the system to wait until the <F1> key is pressed if an error occurs. The options are Disabled and **Enabled**.

#### Interrupt 19 Capture

Interrupt 19 is the software interrupt that handles the boot disk function. When this item is set to Immediate, the ROM BIOS of the host adaptors will "capture" Interrupt 19 at bootup immediately and allow the drives that are attached to the host adaptors to function as bootable disks. If this item is set to Postponed, the ROM BIOS of the host adaptors will not capture Interrupt 19 immediately to allow the drives attached to the adaptors to function as bootable devices at bootup. The options are **Immediate** and Postponed.

#### Re-try Boot

Select EFI Boot to allow the BIOS to automatically reboot the system from an EFI boot device after its initial boot failure. Select Legacy Boot to allow the BIOS to automatically reboot the system from a Legacy boot device after its initial boot failure. The options are **Disabled**, Legacy Boot, and EFI Boot.

## Power Configuration

#### Watch Dog Function

Select Enabled to allow the Watch Dog timer to reboot the system when it is inactive for more than 5 minutes. The options are Enabled and **Disabled**.

#### Power Button Function

This feature controls how the system shuts down when the power button is pressed. Select 4 Seconds Override for the user to power off the system after pressing and holding the power button for 4 seconds or longer. Select Instant Off to instantly power off the system as soon as the user presses the power button. The options are 4 Seconds Override and **Instant Off**.

#### Restore on AC Power Loss

Use this feature to set the power state after a power outage. Select Power Off for the system power to remain off after a power loss. Select Power On for the system power to be turned on after a power loss. Select Last State to allow the system to resume its last power state before a power loss. The options are Power On, Stay Off, and **Last State**.

## ►CPU Configuration

This submenu displays the following CPU information as detected by the BIOS. It also allows the user to configure CPU settings.

- Processor Socket
- Processor ID
- Processor Frequency
- Processor Max Ratio
- Processor Min Ratio
- Microcode Revision
- L1 Cache RAM
- L2 Cache RAM
- L3 Cache RAM
- CPU 1 Version
- CPU 2 Version

### Clock Spread Spectrum

Select Enabled to allow the BIOS to monitor and attempt to reduce the level of Electromagnetic Interference caused by the components whenever needed. The options are **Disabled** and Enabled.

### Hyper-Threading (All)

Select Enable to support Intel's Hyper-threading Technology to enhance CPU performance. The options are **Enable** and Disable.

### Cores Enabled

This feature allows the user to determine the number of CPU cores to enable. Enter "0" to enable all cores. The default setting is **0**, which enables all CPU cores in the system.

### Execute Disable Bit (Available if supported by the OS & the CPU)

Select Enable for Execute Disable Bit Technology support, which will allow the processor to designate areas in the system memory where an application code can execute and where it cannot, thus preventing a worm or a virus from flooding

illegal codes to overwhelm the processor to damage the system during an attack. The options are **Enable** and Disable. (Refer to Intel's and Microsoft's websites for more information.)

### PPIN Control

Select Unlock/Enable to use the Protected-Processor Inventory Number (PPIN) control in the system. The options are **Unlock/Enable** and Unlock/Disable.

### Hardware Prefetcher (Available when supported by the CPU)

If set to Enable, the hardware prefetcher will prefetch streams of data and instructions from the main memory to the L2 cache to improve CPU performance. The options are Disable and **Enable**.

### Adjacent Cache Prefetch (Available when supported by the CPU)

Select Enable for the CPU to prefetch both cache lines for 128 bytes as comprised. Select Disable for the CPU to prefetch both cache lines for 64 bytes. The options are Disable and **Enable**.

**Note:** Please reboot the system for changes on this setting to take effect. Please refer to Intel's website for detailed information.

### DCU (Data Cache Unit) Streamer Prefetcher (Available when supported by the CPU)

If set to Enable, the DCU Streamer prefetcher will prefetch data streams from the cache memory to the DCU (Data Cache Unit) to speed up data accessing and processing to enhance CPU performance. The options are Disable and **Enable**.

### DCU IP Prefetcher

If set to Enable, the IP prefetcher in the DCU (Data Cache Unit) will prefetch IP addresses to improve network connectivity and system performance. The options are **Enable** and Disable.

### Direct Cache Access (DCA)

Select Enable to use Intel DCA (Direct Cache Access) Technology to improve the efficiency of data transferring and accessing. The options are **Auto**, Enable, and Disable.

### X2 APIC (Advanced Programmable Interrupt Controller)

Based on Intel's Hyper-Threading architecture, each logical processor (thread) is assigned 256 APIC IDs (APIDs) in 8-bit bandwidth. When this feature is set to Enable, the APIC ID will expand(X2) from 8 bits to 16 bits to provide 512 APIDs to each thread for CPU performance enhancement. The options are **Disable** and Enable.

**AES-NI**

Select Enable to use the Intel Advanced Encryption Standard (AES) New Instructions (NI) to ensure data security. The options are **Enable** and Disable.

**Intel Virtualization Technology**

Select Enable to use Intel Virtualization Technology support for Direct I/O VT-d support by reporting the I/O device assignments to the VMM (Virtual Machine Monitor) through the DMAR ACPI tables. This feature offers fully-protected I/O resource sharing across Intel platforms, providing greater reliability, security and availability in networking and data-sharing. The options are **Enable** and Disable.

**► Advanced Power Management Configuration****Advanced Power Management Configuration****Power Technology**

Select Energy Efficient to support power-saving mode. Select Custom to customize system power settings. Select Disabled to disable power-saving settings. The options are Disable, **Energy Efficient**, and Custom.

**► CPU P State Control (Available when Power Technology is set to Custom)****EIST (P-States)**

EIST (Enhanced Intel SpeedStep Technology) allows the system to automatically adjust the processor voltage and core frequency to reduce power consumption and heat dissipation. The options are Disable and **Enable**.

**Turbo Mode**

Select Enabled to use the Turbo Mode to boost system performance. The options are **Enable** and Disable.

**P-State Coordination**

This feature is used to change the P-state (Power-Performance State) coordination type. P-state is also known as "SpeedStep" for Intel processors. Select HW\_ALL to change the P-state coordination type for hardware components only. Select SW\_ALL to change the P-state coordination type for all software installed in the system. Select SW\_ANY to change the P-state coordination type for a software program in the system. The options are **HW\_All**, SW\_ALL, and SW\_ANY.

**► CPU C State Control (Available when Power Technology is set to Custom)****Package C State limit**

Use this item to set the limit on the C-State package register. The options are C0/1 state, C2 state, C6 (non-Retention) state, **C6 (Retention) state**, and No Limit.

**CPU C3 Report**

Select Enable to allow the BIOS to report the CPU C3 State (ACPI C2) to the operating system. During the CPU C3 State, the CPU clock generator is turned off. The options are Enable and **Disable**.

**CPU C6 Report (Available when Power Technology is set to Custom)**

Select Enable to allow the BIOS to report the CPU C6 state (ACPI C3) to the operating system. During the CPU C6 state, power to all cache is turned off. The options are **Enable** and Disable.

**Enhanced Halt State (C1E)**

Select Enabled to use Enhanced Halt-State technology, which will significantly reduce CPU power consumption by reducing CPU clock cycles and voltages during a Halt-state. The options are Disable and **Enable**.

**► CPU T State Control (Available when Power Technology is set to Custom)****ACPI (Advanced Configuration Power Interface) T-States**

Select Enable to support CPU throttling by the operating system to reduce power consumption. The options are **Enable** and Disable.

**► Socket RAPL (Running Average Power Limit) Config. (Configuration)****FAST\_RAPL\_NSTRIKE\_PL2\_DUTY\_CYCLE**

This feature displays the value of the item above within the range between 25 (10%) and 64 (25%). The default setting is **64**.

**Turbo Power Limit Lock**

Select Enable to set the power use limit for the machine when it is running in the turbo mode. The options are Enable and **Disable**.

**Long Pwr (Power) Limit Ovr (Override)**

Select Enable to support long-term power limit override. If this feature is disabled, BIOS will set the default value. The options are **Enable** and Disable.

**Long Dur (Duration) Power Limit**

This item displays the power limit set by the user during which long duration power is maintained. The default setting is **0**.

**Long Dur (Duration) Time Window**

Use this item to set the time window value (in seconds) over which the TDP (Thermal Design Point) should be maintained. The default setting is **1**, which will allow the value to be automatically programmed by the system.

**Pkg (Package) Clmp (Clamping) Limit1**

Use this item to set the limit on power performance states for the runtime processor, with P0 being the state with the highest frequency (clock speed) and power (consumption), and P1, a step lower in performance than P0, with its frequency and voltage scaled back a notch. The options are Between P1/P0 and **Below P1**.

**Short Dur (Duration) Pwr (Power) Limit En (Enable)**

Select Enable to support Short Duration Power Limit (Power Limit 2). The options are **Enable** and Disable.

**Short Dur (Duration) Pwr (Power) Limit**

This item displays the time period during which short duration power is maintained. The default setting is **0**.

**Pkg (Package) Clmp (Clamping) Lim2**

Use this item to set the limit on power performance states for the processor operating in turbo mode, with P0 being the state with the highest frequency (clock speed) and power (consumption), and P1, a step lower in performance than P0, with its frequency and voltage scaled back a notch. The options are Between P1/P0 and **Below P1**.

**► DRAM RAPL (Running Average Power Limit) Configuration****DRAM RAPL (Running Average Power Limit) Baseline**

Use this item to set the run-time power-limit baseline for DRAM modules. The options are Disable, DRAM RAPL Mode 0, and **DRAM RAPL Mode 1**.

**Override BW\_LIMIT\_TF (BW\_limit\_tf )**

This feature allows the user to turn off the "Override BW\_Limit\_TF (Time Frame)" setting when the item--the "Running Average Power Limit for DRAM modules" (DRAM RAPL) is set to Enabled so that the DRAM RAPL setting can work properly. The default setting is **1**.

**DRAM RAPL (Running Average Power Limit) Extended Range**

Select Enable to extend the RAPL range for the DRAM modules. The options are Disable and **Enable**.

**► Chipset Configuration**

**Warning!** Please set the correct settings for the items below. A wrong configuration setting may cause the system to become malfunction.

**► North Bridge**

This feature allows the user to configure the settings for the Intel North Bridge.

**► IIO Configuration****EV DFX (Device Function On-Hide) Features**

When this feature is set to Enable, the EV\_DFX Lock Bits that are located on a processor will always remain clear during electric tuning. The options are **Disable** and Enable.

**► IIO0 Configuration****IOU2 (IIO PCIe Port 1)**

This item configures the PCI-E port Bifurcation setting for a PCI-E port specified by the user. The options are x4x4, **x8**, and Auto.

**IOU0 (IIO PCIe Port 2)**

This item configures the PCI-E port Bifurcation setting for a PCI-E port specified by the user. The options are x4x4x4x4, x4x4x8, x8x4x4, **x8x8**, x16, and Auto.

**IOU1 (IIO1 PCIe Port 3)**

This item configures the PCI-E port Bifurcation setting for a PCI-E port specified by the user. The options are x4x4x4x4, x4x4x8, x8x4x4, **x8x8**, x16, and Auto..

**No PCIe Port Active ECO (Engineer Change Order)**

This feature provides a work-around solution when there is no active PCI device detected by the BIOS. The options are **PCU Squelch Exit Ignore Option** and **Reset the SQ FLOP by CSR Option**.

**► Socket 0 PCIeD00F0 - Port 0/DMI****Link Speed**

This item configures the link speed of a PCI-E port specified by the user. The options are Gen 1 (Generation 1) (2.5 GT/s), Gen 2 (Generation 2) (5 GT/s), and **Auto**.

**PCI-E Port DeEmphasis**

This item configures the De-Emphasis Control (LANKCON2 [6]) setting for this computer. The options are **-6.0 dB** and **-3.5 dB**.

The following items will be display:

- PCI-E Port Link Status
- PCI-E Port Link Max
- PCI-E Port Link Speed

**PCI-E Port L0s Exit Latency**

Use this item to set the length of time required for the port specified by the user to complete the transition from L0s to L0. The default setting is **4uS - 8uS**.

**PCI-E Port L1 Exit Latency**

Use this item to set the length of time required for the port specified by the user to complete the transition from L1 to L0. The default setting is **<1uS, 1uS - 2uS, 2uS - 4uS, 4uS - 8uS, 8uS - 16uS, 16uS - 32uS, 32uS - 64uS, and >64uS**.

**Fatal Err (Error) Over**

Select Enable to force fatal error prorogation to the IIO core error logic for the port specified by the user. The options are **Disable** and **Enable**.

**Non-Fatal Err (Error) Over**

Select Enable to force non-fatal error prorogation to the IIO core error logic for the port specified by the user. The options are **Disable** and **Enable**.

**Corr Err (Correctable Error) Over**

Select Enable to force correctable error prorogation to the IIO core error logic for the port specified by the user. The options are **Disable** and **Enable**.

**L0s Support**

When this item is set to **Disable**, IIO will not put its transmitter in the L0s state. The default setting is **Disable**.

**► Socket 0 PCIeD01F0 - Port 1A/Socket 0 PCIeD02F0 - Port 2A/Socket 0 PCIeD20F2 - Port 2C/Socket 0 PCIeD03F0 - Port 3A/Socket 0 PCIeD03F2 - Port 3C****PCI-E Port**

Select **Enable** to enable the PCI-E port specified by the user. The options are **Auto**, **Enable**, and **Disable**.

**Hot Plug Capable**

Select **Enable** to enable hot-plugging support for the PCI-E port specified by the user to allow the user to replace the device installed on the port without shutting down the system. The options are **Disable** and **Enable**.

**PCI-E Port Link**

Select **Disable** to disable the link that is not involved in training activities, but its CFG is still active. The options are **Enable** and **Disable**.

**Link Speed**

Use this item to select the link speed for the PCI-E port specified by the user. The options are **GEN1 (2.5 GT/s), GEN2 (5 GT/s), GEN3 (8 GT/s), and Auto**.

**PCI-E Port DeEmphasis**

Use this item to select the De-Emphasis control setting for a PCI-E port specified by the user. The options are **-6.0 dB** and **-3.5 dB**.

The following items will be display:

- PCI-E Port Link Status
- PCI-E Port Link Max
- PCI-E Port Link Speed

**PCI-E Port L0s Exit Latency**

Use this item to set the length of time required for the port specified by the user to complete the transition from L0s to L0. The default setting is **4uS - 8uS**.

**PCI-E Port L1 Exit Latency**

Use this item to set the length of time required for the port specified by the user to complete the transition from L1 to L0. The default setting is <1uS, 1uS - 2uS, 2uS - 4uS, 4uS - 8uS, **8uS - 16uS**, 16uS - 32uS, 32uS - 64uS, and >64uS.

**Fatal Err (Error) Over**

Select Enable to force fatal error prorogation to the IIO core error logic for the port specified by the user. The options are **Disable** and Enable.

**Non-Fatal Err (Error) Over**

Select Enable to force non-fatal error prorogation to the IIO core error logic for the port specified by the user. The options are **Disable** and Enable.

**Corr Err (Correctable Error) Over**

Select Enable to force correctable error prorogation to the IIO core error logic for the port specified by the user. The options are **Disable** and Enable.

**L0s Support**

When this item is set to Disable, IIO will not put its transmitter in the L0s state. The default setting is **Disable**.

**PM ACPI Support**

Select Enable to generate an \_HPGPE message on a PM ACPI event. Select Disable to generate an MSI message. The options are **Disable** and Enable.

**Gen3 (Generation 3) Eq (Equalization) Mode**

Use this item to set the "Adaptive Equalization" mode for PCI-E Generation 3 devices. The options are **Auto**, Enable Phase 0, 1, 2, 3; Disable Phase 0, 1, 2, 3; Enable Phase 1 Only, Enable Phase 0, 1 Only, Enable MMM Offset West, and Advanced.

**Gen3 (Generation 3) Spec (Specifics) Mode**

Use this item to set the Specifics mode for PCI-E Generation 3 devices. The options are **Auto**, 0.70 July, 0.70 Sept and 071 Sept.

**Gen3 (Generation 3) Phase2 Mode**

Use this item to set the PCI-E Generation 3 Phase 2 mode. The options are **Hardware Adaptive** and Manual.

**Gen3 (Generation 3) DN TX Preset**

Use this item to set the Preset mode for PCI-E Gen3 downstream transmitting (TX) from the master device to a slave device. The options are **Auto**, P0 (-6.0/0.0 dB), P1 (-3.5/0.0 dB), P2 (-4.5/0.0 dB), P3 (-2.5/0.0 dB), P4 (0.0/0.0

dB), P5 (0.0/2.0 dB), P6 (0.0/2.5 dB), P7 (-6.0 /3.5 dB), P8 (-3.5/3.5 dB), and P9 (0.0/3.5 dB).

**Gen3 (Generation 3) DN RX Preset Hint**

Use this item to set the Preset Hint mode for PCI-E Gen3 downstream receiving (RX) from the master device to a slave device. The options are **Auto**, P0 (-6.0 dB), P1 (-7.0 dB), P2 (-8.0 dB), P3 (-9.0 dB), P4 (-10.0 dB) P5 (-11.0 dB), and P6 (-12.0 dB).

**Gen3 (Generation 3) Up TX Preset**

Use this item to set the Preset mode for PCI-E Gen3 upstream transmitting (TX) from a slave device to the master device. The options are **Auto**, P0 (-6.0/0.0 dB), P1 (-3.5/0.0 dB), P2 (-4.5/0.0 dB), P3 (-2.5/0.0 dB), P4 (0.0/0.0 dB), P5 (0.0/2.0 dB), P6 (0.0/2.5 dB), P7 (-6.0/3.5 dB), P8 (-3.5/3.5 dB), and P9 (0.0/3.5 dB).

**Non-Transparent Bridge PCIe Port Definition (Available on the Socket 0 PCIeD03F0 - Port 3A only)**

Select Transparent Bridge to enable Transparent Bridge support for the PCI-E port specified by the user. Please do not select NTB-RP for a legacy IIO device. The options are **Transparent Bridge**, NTB to NTB, and NTB to RP.

**Hide Port?**

Select Yes to hide the PCI-E port specified from the OS. The options are **No** and Yes.

This feature allows the user to configure the settings for the Intel North Bridge.

**► IIO1 Configuration****IIOU2 (IIO PCIe Port 1)**

This item configures the PCI-E port Bifurcation setting for a PCI-E port specified by the user. The options are x4x4, **x8**, and Auto.

**IIOU0 (IIO PCIe Port 2)**

This item configures the PCI-E port Bifurcation setting for a PCI-E port specified by the user. The options are x4x4x4x4, x4x4x8, x8x4x4, **x8x8**, x16, and Auto.

**IIOU1 (IIO1 PCIe Port 3)**

This item configures the PCI-E port Bifurcation setting for a PCI-E port specified by the user. The options are x4x4x4x4, x4x4x8, x8x4x4, x8x8, **x16**, and Auto..

**No PCIe Port Active ECO (Engineer Change Order)**

This feature provides a work-around solution when there is no active PCI device detected by the BIOS. The options are **PCU Squelch Exit Ignore Option** and **Reset the SQ FLOP by CSR Option**.

**►Socket 1 PCIeD00F0 - Port 0/DMI/Socket 1 PCIeD01F0 - Port 1A/Socket 1 PCIeD02F0 - Port 2A/Socket 1 PCIeD20F2 - Port 2C/Socket 1 PCIeD03F0 - Port 3A**

**PCI-E Port**

Select Enable to enable the PCI-E port specified by the user. The options are **Auto**, **Enable**, and **Disable**.

**Hot Plug Capable**

Select Enable to enable hot-plugging support for the PCI-E port specified by the user to allow the user to replace the device installed on the port without shutting down the system. The options are **Disable** and **Enable**.

**PCI-E Port Link**

Select Disable to disable the link that is not involved in training activities, but its CFG is still active. The options are **Enable** and **Disable**.

**Link Speed**

Use this item to select the link speed for the PCI-E port specified by the user. The options are **GEN1 (2.5 GT/s)**, **GEN2 (5 GT/s)**, **GEN3 (8 GT/s)**, and **Auto**.

**PCI-E Port DeEmphasis**

Use this item to select the De-Emphasis control setting for a PCI-E port specified by the user. The options are **-6.0 dB** and **-3.5 dB**.

The following items will be display:

- PCI-E Port Link Status
- PCI-E Port Link Max
- PCI-E Port Link Speed

**PCI-E Port L0s Exit Latency**

Use this item to set the length of time required for the port specified by the user to complete the transition from L0s to L0. The default setting is **4uS - 8uS**.

**PCI-E Port L1 Exit Latency**

Use this item to set the length of time required for the port specified by the user to complete the transition from L1 to L0. The default setting is **<1uS, 1uS - 2uS, 2uS - 4uS, 4uS - 8uS, 8uS - 16uS, 16uS - 32uS, 32uS - 64uS, and >64uS**.

**Fatal Err (Error) Over**

Select Enable to force fatal error prorogation to the IIO core error logic for the port specified by the user. The options are **Disable** and **Enable**.

**Non-Fatal Err (Error) Over**

Select Enable to force non-fatal error prorogation to the IIO core error logic for the port specified by the user. The options are **Disable** and **Enable**.

**Corr Err (Correctable Error) Over**

Select Enable to force correctable error prorogation to the IIO core error logic for the port specified by the user. The options are **Disable** and **Enable**.

**L0s Support**

When this item is set to **Disable**, IIO will not put its transmitter in the L0s state. The default setting is **Disable**.

**PM ACPI Support**

Select Enable to generate an **\_HPGPE** message on a PM ACPI event. Select **Disable** to generate an **MSI** message. The options are **Disable** and **Enable**.

**Gen3 (Generation 3) Eq (Equalization) Mode**

Use this item to set the "Adaptive Equalization" mode for PCI-E Generation 3 devices. The options are **Auto**, **Enable Phase 0, 1, 2, 3**; **Disable Phase 0, 1, 2, 3**; **Enable Phase 1 Only**, **Enable Phase 0, 1 Only**, **Enable MMM Offset West**, and **Advanced**.

**Gen3 (Generation 3) Spec (Specifics) Mode**

Use this item to set the Specifics mode for PCI-E Generation 3 devices. The options are **Auto**, **0.70 July**, **0.70 Sept** and **071 Sept**.

**Gen3 (Generation 3) Phase2 Mode**

Use this item to set the PCI-E Generation 3 Phase 2 mode. The options are **Hardware Adaptive** and **Manual**.

**Gen3 (Generation 3) DN TX Preset**

Use this item to set the Preset mode for PCI-E Gen3 downstream transmitting (TX) from the master device to a slave device. The options are **Auto**, **P0 (-6.0/0.0 dB)**, **P1 (-3.5/0.0 dB)**, **P2 (-4.5/0.0 dB)**, **P3 (-2.5/0.0 dB)**, **P4 (0.0/0.0 dB)**.

dB), P5 (0.0/2.0 dB), P6 (0.0/2.5 dB), P7 (-6.0 /3.5 dB), P8 (-3.5/3.5 dB), and P9 (0.0/3.5 dB).

#### Gen3 (Generation 3) DN RX Preset Hint

Use this item to set the Preset Hint mode for PCI-E Gen3 downstream receiving (RX) from the master device to a slave device. The options are **Auto**, P0 (-6.0 dB), P1 (-7.0 dB), P2 (-8.0 dB), P3 (-9.0 dB), P4 (-10.0 dB) P5 (-11.0 dB), and P6 (-12.0 dB).

#### Gen3 (Generation 3) Up TX Preset

Use this item to set the Preset mode for PCI-E Gen3 upstream transmitting (TX) from a slave device to the master device. The options are **Auto**, P0 (-6.0/0.0 dB), P1 (-3.5/0.0 dB), P2 (-4.5/0.0 dB), P3 (-2.5/0.0 dB), P4 (0.0/0.0 dB), P5 (0.0/2.0 dB), P6 (0.0/2.5 dB), P7 (-6.0/3.5 dB), P8 (-3.5/3.5 dB), and P9 (0.0/3.5 dB).

#### Non-Transparent Bridge PCIe Port Definition (Available on the Socket 1 PCIeD03F0 - Port 3A only)

Select Transparent Bridge to enable Transparent Bridge support for the PCI-E port specified by the user. Please do not select NTB-RP for a legacy IIO device. The options are **Transparent Bridge**, NTB to NTB, and NTB to RP.

#### Hide Port?

Select Yes to hide the PCI-E port specified from the OS. The options are **No** and Yes.

### ► IOAT (Intel® IO Acceleration) Configuration

#### Enable IOAT

Select Enable to enable Intel I/OAT (I/O Acceleration Technology) support, which significantly reduces CPU overhead by leveraging CPU architectural improvements and freeing the system resource for other tasks. The options are **Enable** and Disable.

#### No Snoop

Select Enable to support no-snoop mode for each CB device. The options are **Disable** and Enable.

#### Relaxed Ordering

Select Enable to enable Relaxed Ordering support which will allow certain transactions to violate the strict-ordering rules of PCI bus for a transaction to be completed prior to other transactions that have already been enqueued. The options are **Disable** and Enable.

### ► Intel VT for Directed I/O (VT-d)

#### Intel® VT for Directed I/O (VT-d)

Select Enable to use Intel Virtualization Technology for Direct I/O VT-d support by reporting the I/O device assignments to the VMM (Virtual Machine Monitor) through the DMAR ACPI tables. This feature offers fully-protected I/O resource sharing across Intel platforms, providing greater reliability, security and availability in networking and data-sharing. The options are **Enable** and Disable.

#### Interrupt Remapping

Select Enable for Interrupt Remapping support to enhance system performance. The options are **Enable** and Disable.

### ► QPI (Quick Path Interconnect) Configuration

#### ► QPI General Configuration

#### ► QPI Status

The following information will display:

- Number of CPU
- Number of IIO
- Current QPI Link Speed
- Current QPI Link Frequency
- QPI Global MMIO Low Base/Limit
- QPI Global MMIO High Base/Limit
- QPI PCIe Configuration Base/Size

#### Link Frequency Select

Use this item to select the desired frequency for QPI Link connections. The options are 6.4GB/s, 8.0GB/s, 9.6GB/s, **Auto**, and Auto Limited.

#### Link L0p Enable

Select Enable for Link L0p support to reduce power consumption. The options are **Enable** and Disable.

**Link L1 Enable**

Select Enable for Link L1 support to reduce power consumption. The options are **Enable** and **Disable**.

**COD Enable (Available when the OS and the CPU support this feature)**

Select Enable for Cluster-On-Die support to enhance system performance in cloud computing. The options are **Enable** and **Disable**.

**Early Snoop (Available when the OS and the CPU support this feature)**

Select Enable for Early Snoop support to enhance system performance. The options are **Enable**, **Disable**, and **Auto**.

**Isoc Mode**

Select Enable for Isochronous support to meet QoS (Quality of Service) requirements. This feature is especially important for Intel Virtualization Technology. The options are **Enable** and **Disable**.

**►Memory Configuration**

This submenu allows the user to configure Integrated Memory Controller (IMC) settings.

**Enforce POR**

Select Enabled to enforce POR restrictions on DDR4 frequency and voltage programming. The options are **Enabled** and **Disabled**.

**Memory Frequency**

Use this feature to set the maximum memory frequency for onboard memory modules. The options are **Auto**, 1333, 1400, 1600, 1800, 1867, 2000, 2133, 2200, 2400, 2600, 2667, 2800, 2993, 3000, 3200, and **Reserved** (Do not select **Reserved**).

**Data Scrambling**

Select Enabled to enable data scrambling to enhance system performance and data integrity. The options are **Auto**, **Disabled** and **Enabled**.

**DRAM RAPL (Running Average Power Limit) Baseline**

Use this feature to set the run-time power-limit baseline for DRAM modules. The options are **Disable**, **DRAM RAPL Mode 0**, and **DRAM RAPL Mode 1**.

**Set Throttling Mode**

Throttling improves CPU reliability and reduces power consumption via automatic-voltage control during CPU idle states. The options are **Disabled** and **CLTT** (Closed Loop Thermal Throttling).

**Socket Interleave Below 4GB**

Select Enable for the memory above the 4G Address space to be split between two sockets. The options are **Enable** and **Disable**.

**A7 Mode**

Select Enable to support the A7 (Addressing) mode to improve memory performance. The options are **Enable** and **Disable**.

**►DIMM Information**

This item displays the status of a DIMM module as detected by the AMI BIOS.

- P1 DIMMA1
- P2 DIMME1

**►Memory RAS (Reliability\_Availability\_Serviceability) Configuration**

Use this submenu to configure the following Memory RAS settings.

**RAS Mode**

When **Disable** is selected, RAS is not supported. When **Mirror** is selected, the motherboard maintains two identical copies of all data in memory for data backup. When **Lockstep** is selected, the motherboard uses two areas of memory to run the same set of operations in parallel to boost performance. The options are **Disable**, **Mirror**, and **Lockstep Mode**.

**Memory Rank Sparing**

Select **Enable** to enable memory-sparing support for memory ranks to improve memory performance. The options are **Disabled** and **Enabled**.

**Patrol Scrub**

Patrol Scrubbing is a process that allows the CPU to correct correctable memory errors detected on a memory module and send the correction to the requestor (the original source). When this item is set to **Enable**, the IO hub will read and write back one cache line every 16K cycles, if there is no delay caused by internal processing. By using this method, roughly 64 GB of memory behind the IO hub will be scrubbed every day. The options are **Enable** and **Disable**.

**Patrol Scrub Interval**

This feature allows you to decide how many hours the system should wait before the next complete patrol scrub is performed. Use the keyboard to enter a value from 0-24. The Default setting is **24**.

**Demand Scrub**

Demand Scrubbing is a process that allows the CPU to correct correctable memory errors found on a memory module. When the CPU or I/O issues a demand-read command, and the read data from memory turns out to be a correctable error, the error is corrected and sent to the requestor (the original source). Memory is updated as well. Select Enable to use Demand Scrubbing for ECC memory correction. The options are **Enable** and Disable.

**Device Tagging**

Select Enable to support device tagging. The options are **Disable** and Enable.

**►South Bridge Configuration**

The following South Bridge information will display:

**►USB Configuration**

- USB Module Version
- USB Devices

**Legacy USB Support**

Select Enabled to support onboard legacy USB devices. Select Auto to disable legacy support if there are no legacy USB devices present. Select Disabled to have all USB devices available for EFI applications only. The options are **Enabled**, Disabled and Auto.

**XHCI Hand-Off**

This is a work-around solution for operating systems that do not support XHCI (Extensible Host Controller Interface) hand-off. The XHCI ownership change should be claimed by the XHCI driver. The settings are **Enabled** and Disabled.

**EHCI Hand-Off**

This item is for operating systems that do not support Enhanced Host Controller Interface (EHCI) hand-off. When this item is enabled, EHCI ownership change will be claimed by the EHCI driver. The settings are Enabled and **Disabled**.

**Port 60/64 Emulation**

Select Enabled to support I/O port 60h/64h emulation, which will provide complete legacy USB keyboard support for the operating systems that do not support legacy USB devices. The options are Disabled and **Enabled**.

**USB 3.0 Support**

Select Enabled for USB 3.0 support. The options are Smart Auto, Auto, Enabled, and **Disabled**.

**EHCI1**

Select Enabled to enable EHCI (Enhanced Host Controller Interface) support on USB 2.0 connector #1 (-at least one USB 2.0 connector should be enabled for EHCI support.) The options are Disabled and **Enabled**.

**EHCI2**

Select Enabled to enable EHCI (Enhanced Host Controller Interface) support on USB 2.0 connector #2 (-at least one USB 2.0 connector should be enabled for EHCI support.) The options are Disabled and **Enabled**.

## ►SATA Configuration

When this submenu is selected, AMI BIOS automatically detects the presence of the SATA devices that are supported by the Intel PCH chip and displays the following items:

### SATA Controller

Select Enabled to enable the onboard SATA controller supported by the Intel PCH chip. The options are **Enabled** and Disabled.

### Configure SATA as

Select IDE to configure a SATA drive specified by the user as an IDE drive. Select AHCI to configure a SATA drive specified by the user as an AHCI drive. Select RAID to configure a SATA drive specified by the user as a RAID drive. The options are IDE, **AHCI**, and RAID.

*\*If the item above "Configure SATA as" is set to AHCI, the following items will display:*

### Support Aggressive Link Power Management

When this item is set to Enabled, the SATA AHCI controller manages the power usage of the SATA link. The controller will put the link to a low power state when the I/O is inactive for an extended period of time, and the power state will return to normal when the I/O becomes active. The options are **Enabled** and Disabled.

### SATA Port 0~ Port 5

This item displays the information of a SATA device installed on the SATA port specified by the user.

- Model number of drive and capacity
- Software Preserve

### Port 0~ Port 5

Select Enabled to enable a SATA port specified by the user. The options are Disabled and **Enabled**.

### Spin Up Device

On an edge detect from 0 to 1, set this item to allow the PCH to initialize the device. The options are Enabled and **Disabled**.

### SATA Device Type

Use this item to specify if the SATA port specified by the user should be connected to a Solid State drive or a Hard Disk Drive. The options are **Hard Disk Drive** and Solid State Drive.

*\*If the item above "Configure SATA as" is set to IDE, the following items will display:*

### SATA Port 0~ Port 5

This item displays the information of a SATA device installed on the SATA port specified by the user.

- Software Preserve

### SATA Device Type (Available when a SATA port is detected)

Use this item to specify if the SATA port specified by the user should be connected to a Solid State drive or a Hard Disk Drive. The options are **Hard Disk Drive** and Solid State Drive.

*\*If the item above "Configure SATA as" is set to RAID, the following items will display:*

### Support Aggressive Link Power Management

When this item is set to Enabled, the SATA AHCI controller manages the power usage of the SATA link. The controller will put the link to a low power state when the I/O is inactive for an extended period of time, and the power state will return to normal when the I/O becomes active. The options are **Enabled** and Disabled.

### SATA RAID Option ROM/UEFI Driver

Select EFI to load the EFI driver for system boot. Select Legacy to load a legacy OPROM for system boot. The options are Disabled, EFI, and **Legacy**.

### SATA/sSATA RAID Boot Select

Select SATA Controller to boot the system from a SATA RAID device. Select sSATA Controller to boot the system from a sSATA RAID device. Select Both to boot the system either from a SATA RAID device or from an sSATA RAID device. Please note that the option-Both is not supported by the Windows Server 2012/R2 OS. The options are None, Both, SATA Controller, and **sSATA Controller**.

### Serial ATA Port 0~ Port 5

This item displays the information of a SATA device installed on the SATA port specified by the user.

- Model number of drive and capacity
- Software Preserve

**Port 0~ Port 5**

Select Enabled to enable a SATA port specified by the user. The options are Disabled and **Enabled**.

**Spin Up Device**

On an edge detect from 0 to 1, set this item to allow the PCH to start a COMRESET initialization to the device. The options are Enabled and **Disabled**.

**SATA Device Type**

Use this item to specify if the SATA port specified by the user should be connected to a Solid State drive or a Hard Disk Drive. The options are **Hard Disk Drive** and Solid State Drive.

**►sSATA Configuration**

When this submenu is selected, AMI BIOS automatically detects the presence of the SATA devices that are supported by the PCH-sSATA controller and displays the following items:

**sSATA Controller**

This item enables or disables the onboard SATA controller supported by the Intel PCH-sSATA controller. The options are **Enabled** and Disabled.

**Configure sSATA as**

Select IDE to configure an sSATA drive specified by the user as an IDE drive. Select AHCI to configure an sSATA drive specified by the user as an AHCI drive. Select RAID to configure an sSATA drive specified by the user as a RAID drive. The options are IDE, **AHCI**, and RAID.

*\*If the item above "Configure sSATA as" is set to AHCI, the following items will display:*

**Support Aggressive Link Power Management**

When this item is set to Enabled, the SATA AHCI controller manages the power usage of the SATA link. The controller will put the link to a low power state when the I/O is inactive for an extended period of time, and the power state will return to normal when the I/O becomes active. The options are **Enabled** and Disabled.

**sSATA Port 0~ Port 3**

This item displays the information detected on the installed on the sSATA port. specified by the user.

- Model number of drive and capacity

**sSATA Port 0~ Port 3**

Select Enabled to enable an sSATA port specified by the user. The options are Disabled and **Enabled**.

**Spin Up Device**

On an edge detect from 0 to 1, set this item to allow the PCH to start a COMRESET initialization to the device. The options are Enabled and **Disabled**.

**Device Type**

Use this item to specify if the sSATA port specified by the user should be connected to a Solid State drive or a Hard Disk Drive. The options are **Hard Disk Drive** and Solid State Drive.

*\*If the item above "Configure sSATA as" is set to IDE, the following items will display:*

**sSATA Port 0~ Port 3**

This item indicates that an sSATA port specified by the user is installed (present) or not.

**sSATA Device Type (Available when a sSATA port is detected)**

Use this item to specify if the sSATA port specified by the user should be connected to a Solid State drive or a Hard Disk Drive. The options are **Hard Disk Drive** and Solid State Drive.

*\*If the item above "Configure sSATA as" is set to RAID, the following items will display:*

**Support Aggressive Link Power Management**

When this item is set to Enabled, the SATA AHCI controller manages the power usage of the sSATA link. The controller will put the link to a low power state when the I/O is inactive for an extended period of time, and the power state will return to normal when the I/O becomes active. The options are **Enabled** and Disabled.

**sSATA RAID Option ROM/UEFI Driver**

Select EFI to load the EFI driver for system boot. Select Legacy to load a legacy OPROM for system boot. The options are Disabled, EFI, and **Legacy**.

**SATA/sSATA RAID Boot Select**

Select SATA Controller to boot the system from a SATA RAID device. Select sSATA Controller to boot the system from a sSATA RAID device. Select Both to boot the system either from a SATA RAID device or from an sSATA RAID device. Please note that the option-Both is not supported by the Windows Server 2012/R2 OS. The options are None, Both, SATA Controller, and **sSATA Controller**.

**sSATA Port 0~ Port 3**

Select Enabled to enable an sSATA port specified by the user. The options are Disabled and Enabled.

**Spin Up Device**

On an edge detect from 0 to 1, set this item to allow the PCH to start a COMRESET initialization to the device. The options are Enabled and **Disabled**.

**Device Type**

Use this item to specify if the sSATA port specified by the user should be connected to a Solid State drive or a Hard Disk Drive. The options are **Hard Disk Drive** and Solid State Drive.

**► Server ME (Management Engine) Configuration**

This feature displays the following system ME configuration settings.

- General ME Configuration
- Operational Firmware Version
- Recovery Firmware Version
- ME Firmware Features
- ME Firmware Status #1
- ME Firmware Status #2
  - Current State
  - Error Code

**Altitude**

This item indicates the altitude of this machine that is above the sea level. The value is shown in meters. If the value is unknown, enter the number "**8000000**".

**MCTP (Management Component Transport Protocol) Bus Owner**

This item indicates the location of the MCTP Bus owner. Enter **0**'s to all fields to disable the MCTP Bus owner.

**► PCIe/PCI/PnP Configuration****PCI Latency Timer**

Use this item to configure the PCI latency timer for a device installed on a PCI bus. Select 32 to set the PCI latency timer to 32 PCI clock cycles. The options are **32**, 64, 96, 128, 160, 192, 224, and 248 (PCI Bus Clocks).

**PERR# Generation**

Select Enabled to allow a PCI device to generate a PERR (PCI/PCI-E Parity Error) number for a PCI bus error event. The options are Enabled and **Disabled**.

**SERR# Generation**

Select Enabled to allow a PCI device to generate an SERR (System Error) number for a PCI bus error event. The options are Enabled and **Disabled**.

**PCI PERR/SERR Support**

Select Enabled to support PERR (PCI/PCI-E Parity Error)/SERR (System Error) runtime error reporting for a PCI/PCI-E slot. The options are Enabled and **Disabled**.

**Above 4G Decoding (Available if the system supports 64-bit PCI decoding)**

Select Enabled to decode a PCI device that supports 64-bit in the space above 4G Address. The options are Enabled and **Disabled**.

**SR-IOV (Available if the system supports Single-Root Virtualization)**

Select Enabled for Single-Root IO Virtualization support. The options are Enabled and **Disabled**.

**Maximum Payload**

Select Auto for the system BIOS to automatically set the maximum payload value for a PCI-E device to enhance system performance. The options are **Auto**, 128 Bytes, 256 Bytes, 512 Bytes, 1024 Bytes, 2048 Bytes, and 4096 Bytes.

**Maximum Read Request**

Select Auto for the system BIOS to automatically set the maximum size for a read request for a PCI-E device to enhance system performance. The options are **Auto**, 128 Bytes, 256 Bytes, 512 Bytes, 1024 Bytes, 2048 Bytes, and 4096 Bytes.

**ASPM Support**

Use this item to set the Active State Power Management (ASPM) level for a PCI-E device. Select Auto for the system BIOS to automatically set the ASPM level based on the system configuration. Select Disabled to disable ASPM support. The options are **Disabled** and Auto.

**Warning:** Enabling ASPM support may cause some PCI-E devices to fail!

**MMIOHBase**

Use this item to select the I/O base memory size according to memory-address mapping for the PCH chip. The base memory size must be between 4032G to 4078G. The options are **56T**, 48T, 24T, 2T, 512G, and 256G.

**MMIO High Size**

Use this item to select the high I/O memory size according to memory-address mapping for the PCH chip. The options are **256G**, 128G, 512G, and 1024G.

**PCI Devices Option ROM Setting****CPU1 Slot1 PCI-E x8 OPROM/CPU1 Slot2 PCI-E x16 OPROM/CPU1 Slot3 PCI-E x8 OPROM/CPU2 Slot4 PCI-E x16 OPROM/CPU2 Slot5 PCI-E x8 OPROM/CPU2 Slot6 PCI-E x16 OPROM/CPU2 Slot7 PCI-E x16 OPROM/ Onboard Video Option ROM**

Select Enabled to enable Option ROM support to boot the computer using a device installed on the slot specified by the user. The options are Disabled, **Legacy**, and EFI.

**Onboard LAN Option ROM Type**

Select Enabled to enable Option ROM support to boot the computer using a device installed on the slot specified by the user. The options are **Legacy** and EFI.

**VGA Priority**

Use this item to select the graphics device to be used as the primary video display for system boot. The options are **Onboard** and Offboard.

**Onboard LAN1 Option ROM/Onboard LAN2 Option ROM**

Use this option to select the type of device installed in LAN Port1 or LAN Port2 for system boot. The default setting for LAN1 Option ROM is **PXE**, and for LAN2 Option ROM is **Disabled**.

**Network Stack**

Select Enabled to enable PXE (Preboot Execution Environment) or UEFI (Unified Extensible Firmware Interface) for network stack support. The options are Enabled and **Disabled**.

**►Super IO Configuration****Super IO Chip AST2400****►Serial Port 1 Configuration/Serial Port 2 Configuration****Serial Port 1/Serial Port 2**

Select Enabled to enable the onboard serial port specified by the user. The options are **Enabled** and Disabled.

**Device Settings**

This item displays the base I/O port address and the Interrupt Request address for a serial port specified by the user. The default setting for Serial Port 1 is IO=3F8h IRQ=4; for Serial Port 2 is IO=2F8h, IRQ=3.

**Change Port 1 Settings/Change Port 2 Settings**

This feature specifies the base I/O port address and the Interrupt Request address of Serial Port 1 or Serial Port 2. Select **Auto** for the BIOS to automatically assign the base I/O and IRQ address to a serial port specified.

The options for Serial Port 1 are **Auto**, (IO=3F8h; IRQ=4), (IO=3F8h; IRQ=3, 4, 5, 6, 7, 10, 11, 12), (IO=2F8h; IRQ=3, 4, 5, 6, 7, 10, 11, 12); (IO=3E8h; IRQ=3, 4, 5, 6, 7, 10, 11, 12), and (IO=2E8h; IRQ=3, 4, 5, 6, 7, 10, 11, 12).

The options for Serial Port 2 are **Auto**, (IO=2F8h; IRQ=3), (IO=3F8h; IRQ=3, 4, 5, 6, 7, 10, 11, 12), (IO=2F8h; IRQ=3, 4, 5, 6, 7, 10, 11, 12); (IO=3E8h; IRQ=3, 4, 5, 6, 7, 10, 11, 12), and (IO=2E8h; IRQ=3, 4, 5, 6, 7, 10, 11, 12).

**Device Mode**

Use this item to select the SUART Clock source for a serial port specified by the user. The options are **24MHz/13** and 24MHz.

**Serial Port 2 Attribute**

Select SOL to use COM Port 2 as a Serial\_Over\_LAN (SOL) port for console redirection. The options are COM and **SOL**.

**►Serial Port Console Redirection****COM 1****COM 1 Console Redirection**

Select Enabled to enable COM Port 1 Console Redirection, which will allow a client machine to be connected to a host machine at a remote site for networking. The options are **Disabled** and Enabled.

*\*If the item above set to Enabled, the following items will become available for configuration:*

## ►COM1 Console Redirection Settings

### Terminal Type

Use this item to select the target terminal emulation type for Console Redirection. Select VT100 to use the ASCII Character set. Select VT100+ to add color and function key support. Select ANSI to use the Extended ASCII Character set. Select VT-UTF8 to use UTF8 encoding to map Unicode characters into one or more bytes. The options are ANSI, VT100, **VT100+**, and VT-UTF8.

### Bits Per second

Use this item to set the transmission speed for a serial port used in Console Redirection. Make sure that the same speed is used in the host computer and the client computer. A lower transmission speed may be required for long and busy lines. The options are 9600, 19200, 38400, 57600 and **115200** (bits per second).

### Data Bits

Use this item to set the data transmission size for Console Redirection. The options are 7 (Bits) and **8 (Bits)**.

### Parity

A parity bit can be sent along with regular data bits to detect data transmission errors. Select Even if the parity bit is set to 0, and the number of 1's in data bits is even. Select Odd if the parity bit is set to 0, and the number of 1's in data bits is odd. Select None if you do not want to send a parity bit with your data bits in transmission. Select Mark to add a mark as a parity bit to be sent along with the data bits. Select Space to add a Space as a parity bit to be sent with your data bits. The options are **None**, Even, Odd, Mark and Space.

### Stop Bits

A stop bit indicates the end of a serial data packet. Select 1 Stop Bit for standard serial data communication. Select 2 Stop Bits if slower devices are used. The options are **1** and 2.

### Flow Control

Use this item to set the flow control for Console Redirection to prevent data loss caused by buffer overflow. Send a "Stop" signal to stop sending data when the receiving buffer is full. Send a "Start" signal to start sending data when the receiving buffer is empty. The options are **None** and Hardware RTS/CTS.

### VT-UTF8 Combo Key Support

Select Enabled to enable VT-UTF8 Combination Key support for ANSI/VT100 terminals. The options are **Enabled** and Disabled.

### Recorder Mode

Select Enabled to capture the data displayed on a terminal and send it as text messages to a remote server. The options are **Disabled** and Enabled.

### Resolution 100x31

Select Enabled for extended-terminal resolution support. The options are Disabled and **Enabled**.

### Legacy OS Redirection Resolution

Use this item to select the number of rows and columns used in Console Redirection for legacy OS support. The options are 80x24 and **80x25**.

### Putty KeyPad

Use this item to select Function Keys and KeyPad settings for Putty, which is a terminal emulator designed for the Windows OS. The options are **VT100**, LINUX, XTERMR6, SCO, ESCN, and VT400.

### Redirection After BIOS Post

Use this item to enable or disable legacy Console Redirection after BIOS POST (Power-On Self-Test). When "Bootloader" is selected, legacy Console Redirection is disabled before booting the OS. When "Always Enable" is selected, legacy Console Redirection remains enabled while the OS boots up. The options are **Always Enable** and Bootloader.

## SOL/COM2

### SOL/COM2 Console Redirection

Select Enabled to use the SOL port for Console Redirection. The options are **Enabled** and Disabled.

*\*If the item above set to Enabled, the following items will become available for user's configuration:*

## ► SOL/COM2 Console Redirection Settings

Use this feature to specify how the host computer will exchange data with the client computer, which is the remote computer used by the user.

### Terminal Type

Use this feature to select the target terminal emulation type for Console Redirection. Select VT100 to use the ASCII Character set. Select VT100+ to add color and function key support. Select ANSI to use the Extended ASCII Character Set. Select VT-UTF8 to use UTF8 encoding to map Unicode characters into one or more bytes. The options are ANSI, VT100, **VT100+**, and VT-UTF8.

### Bits Per second

Use this feature to set the transmission speed for a serial port used in Console Redirection. Make sure that the same speed is used in the host computer and the client computer. A lower transmission speed may be required for long and busy lines. The options are 9600, 19200, 38400, 57600 and **115200** (bits per second).

### Data Bits

Use this feature to set the data transmission size for Console Redirection. The options are 7 (Bits) and **8 (Bits)**.

### Parity

A parity bit can be sent along with regular data bits to detect data transmission errors. Select Even if the parity bit is set to 0, and the number of 1's in data bits is even. Select Odd if the parity bit is set to 0, and the number of 1's in data bits is odd. Select None if you do not want to send a parity bit with your data bits in transmission. Select Mark to add a mark as a parity bit to be sent along with the data bits. Select Space to add a Space as a parity bit to be sent with your data bits. The options are **None**, Even, Odd, Mark and Space.

### Stop Bits

A stop bit indicates the end of a serial data packet. Select 1 Stop Bit for standard serial data communication. Select 2 Stop Bits if slower devices are used. The options are **1** and 2.

### Flow Control

Use this feature to set the flow control for Console Redirection to prevent data loss caused by buffer overflow. Send a "Stop" signal to stop sending data when the receiving buffer is full. Send a "Start" signal to start data-sending when the receiving buffer is empty. The options are **None** and Hardware RTS/CTS.

## VT-UTF8 Combo Key Support

Select Enabled to enable VT-UTF8 Combination Key support for ANSI/VT100 terminals. The options are **Enabled** and Disabled.

### Recorder Mode

Select Enabled to capture the data displayed on a terminal and send it as text messages to a remote server. The options are **Disabled** and Enabled.

### Resolution 100x31

Select Enabled for extended-terminal resolution support. The options are Disabled and **Enabled**.

### Legacy OS Redirection Resolution

Use this feature to select the number of rows and columns used in Console Redirection for legacy OS support. The options are 80x24 and **80x25**.

### Putty KeyPad

This feature selects Function Keys and KeyPad settings for Putty, which is a terminal emulator designed for the Windows OS. The options are **VT100**, LINUX, XTERMR6, SCO, ESCN, and VT400.

### Redirection After BIOS Post

Use this feature to enable or disable legacy Console Redirection after BIOS POST (Power-On Self-Test). When this feature is set to Bootloader, legacy Console Redirection is disabled before booting the OS. When this feature is set to Always Enable, legacy Console Redirection remains enabled upon OS boot. The options are **Always Enable** and Bootloader.

### Legacy Console Redirection

The submenu allows the user to configure Legacy Console Redirection settings so that legacy devices can be used for Console Redirection.

## ► Legacy Console Redirection Settings

Use this feature to specify how the host computer will communicate with the client compute at a remote site via legacy devices.

### Legacy Serial Redirection Port

The feature selects a legacy serial port to be used for Console Redirection. The options are **COM1 Console Redirection** and COM2/SOL Console Redirection.

### Serial Port for Out-of-Band Management/Windows Emergency Management Services (EMS)

The submenu allows the user to configure Console Redirection settings to support Out-of-Band Serial Port management.

#### (EMS) Console Redirection

Select Enabled to use a COM port selected by the user for EMS Console Redirection. The options are Enabled and **Disabled**.

\*If the item above set to Enabled, the following items will become available for user's configuration:

### ►EMS Console Redirection Settings (Available when EMS Console Redirection is enabled)

Use this feature to specify how the host computer will exchange data with the client computer, which is the remote computer used by the user.

#### Out-of-Band Management Port

The feature selects a serial port in a client server to be used by the Windows Emergency Management Services (EMS) to communicate with a remote host server. The options are **COM1 (Console Redirection)** and COM2/SOL (Console Redirection).

#### Terminal Type

Use this feature to select the target terminal emulation type for Console Redirection. Select VT100 to use the ASCII character set. Select VT100+ to add color and function key support. Select ANSI to use the extended ASCII character set. Select VT-UTF8 to use UTF8 encoding to map Unicode characters into one or more bytes. The options are ANSI, VT100, VT100+, and **VT-UTF8**.

#### Bits Per Second

This item sets the transmission speed for a serial port used in Console Redirection. Make sure that the same speed is used in both host computer and the client computer. A lower transmission speed may be required for long and busy lines. The options are 9600, 19200, 57600, and **115200** (bits per second).

#### Flow Control

Use this item to set the flow control for Console Redirection to prevent data loss caused by buffer overflow. Send a "Stop" signal to stop data-sending when the receiving buffer is full. Send a "Start" signal to start data-sending when the receiving buffer is empty. The options are **None**, Hardware RTS/CTS, and Software Xon/Xoff.

The following settings will be displayed:

### Data Bits, Parity, Stop Bits

### ►Enabling TPM in the BIOS

The steps below describe the proper procedure on how to enable the TPM in the BIOS. This process is necessary to activate support in the system before you can start using the TPM.

1. Enter the BIOS setup screen. You may do this either from the IPMI remote console or from the server directly using KVM. Reboot the system and press the <Del> key as the system boots until you reach the BIOS screen.
2. You will be presented with the BIOS setup main screen. Using the arrow keys, navigate to the Advanced tab. From there, navigate down and select the "CPU Configuration" option as shown below. Press <Enter>.
3. You will be taken to the CPU Configuration page. Using the arrow keys, navigate down to the "Intel Virtualization Technology" option and press <Enter>. Select "Enable" and press <Enter>.



4. Once you have enabled virtualization support, press your <Esc> key until you are back to the Advanced tab. Navigate down to the "Trusted Computing" option and press <Enter>.
5. The Trusted Computing window will appear. Select "TPM State" and press <Enter>.

6. From the window that pops up, select "Enabled" and press <Enter>.

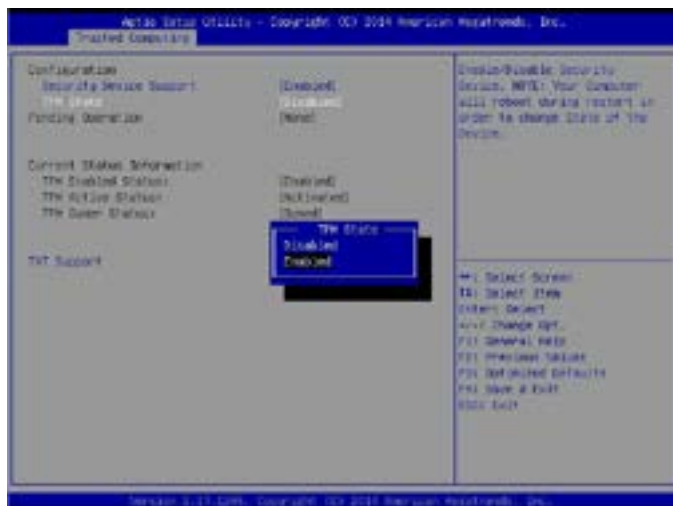

7. You must save your changes and reset for the changes to take effect. Scroll to the Save & Exit tab and select "Save Changes and Reset." The TPM is now enabled.

### ►Intel TXT (LT-SX) Configuration

This submenu allows the user to configure the following TXT settings.

#### TXT Support

Select Enabled to enable Intel Trusted Execution Technology (TXT) support. The options are **Disabled** and Enabled.

**Note:** If the option for this item (TXT Support) is set to Enabled, be sure to disable EV DFX (Device Function On-Hide) support for the system to work properly. (EV DFX is under "I/O Configuration" in the "Chipset/North Bridge" submenu on Page 4-11).

**Note:** For more information on TPM, please refer to the TPM manual at [http://www.supermicro.com/manuals/other/AOM-TPM-9655V\\_9655H.pdf](http://www.supermicro.com/manuals/other/AOM-TPM-9655V_9655H.pdf)

### ►ACPI Settings

#### WHEA Support

Select Enabled to support the Windows Hardware Error Architecture (WHEA) platform and provide a common infrastructure for the system to handle hardware errors within the Windows OS environment to reduce system crashes and to enhance system recovery and health monitoring. The options are **Enabled** and Disabled.

#### High Precision Event Timer

Select Enabled to activate the High Precision Event Timer (HPET) that produces periodic interrupts at a much higher frequency than a Real-time Clock (RTC) does in synchronizing multimedia streams, providing smooth playback and reducing the dependency on other timestamp calculation devices, such as an x86 RDTSC Instruction embedded in the CPU. The High Performance Event Timer is used to replace the 8254 Programmable Interval Timer. The options are **Enabled** and Disabled.

#### NUMA (Available when the OS supports this feature)

Select Enabled to enable Non-Uniform Memory Access support to enhance system performance. The options are **Enabled** and Disabled.

### ►iSCSI Configuration

This item displays iSCSI configuration information:

#### iSCSI Initiator Name

Use this item to enter the name of the iSCSI Initiator, which is a unique name used in the world. The name must in the IQN format. The following submenu will be available for configuration:

#### ► Add an Attempt

#### ► Delete Attempts

#### ► Change Attempt Order

## 7-4 Event Logs

This submenu allows the user to configure Event Log settings.

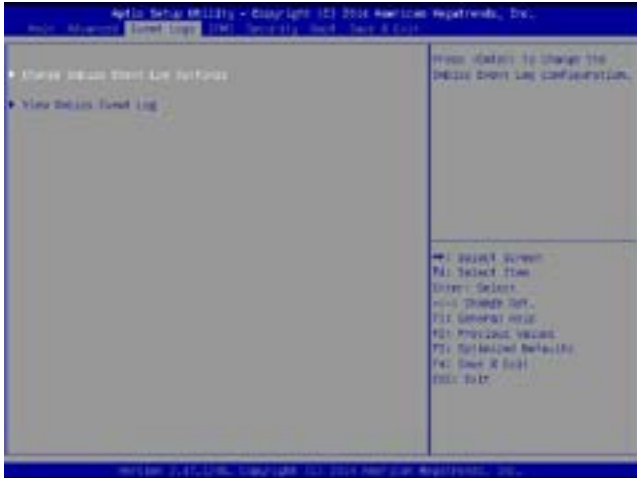

### ►Change SMBIOS Event Log Settings

This feature allows the user to configure SMBIOS Event settings.

#### Enabling/Disabling Options

##### SMBIOS Event Log

Select Enabled to enable SMBIOS (System Management BIOS) Event Logging during system boot. The options are **Enabled** and Disabled.

##### Runtime Error Logging Support

Select Enable to support Runtime Error logging. The options are **Enabled** and Disabled. If this item is set to Enabled, the following item will be available for configuration:

#### Erasing Settings

##### Erase Event Log

Select Yes to erase all error events in the SMBIOS (System Management BIOS) log before an event logging is initialized at bootup. The options are **No**, Yes, Next reset, and Yes, every reset.

#### When Log is Full

Select Erase Immediately to immediately erase all errors in the SMBIOS event log when the event log is full. Select Do Nothing for the system to do nothing when the SMBIOS event log is full. The options are **Do Nothing** and Erase Immediately.

#### SMBIOS Event Log Standard Settings

##### Log System Boot Event

Select Enabled to log system boot events. The options are **Disabled** and Enabled.

##### MECI (Multiple Event Count Increment)

Enter the increment value for the multiple event counter. Enter a number between 1 to 255. The default setting is 1.

##### METW (Multiple Event Count Time Window)

This item is used to determine how long (in minutes) the multiple event counter should wait before generating a new event log. Enter a number between 0 to 99. The default setting is 60.

**Note:** Please reboot the system for the changes to take effect.

### ►View SMBIOS Event Log

This item allows the user to view the event in the SMBIOS event log. The following categories are displayed:

#### Date/Time/Error Code/Severity

#### BMC (Baseboard Management Controller) Firmware Revision

This item indicates the BMC firmware revision used in your system.

#### Status of BMC

This item indicates the status of the onboard BMC chip installed in your system.



## 7-6 Security Settings

This submenu allows the user to configure the following security settings for the system.



### Administrator Password

Use this feature to set the administrator password which is required before entering the BIOS setup utility. The length of the password should be from 3 characters to 20 characters long.

### User Password (Available after an Administrator Password is entered)

Use this feature to set the user password which is required to enter the BIOS setup utility. The length of the password should be from 3 characters to 20 characters long.

## 7-7 Boot Settings

This submenu allows the user to configure Boot settings for this system:

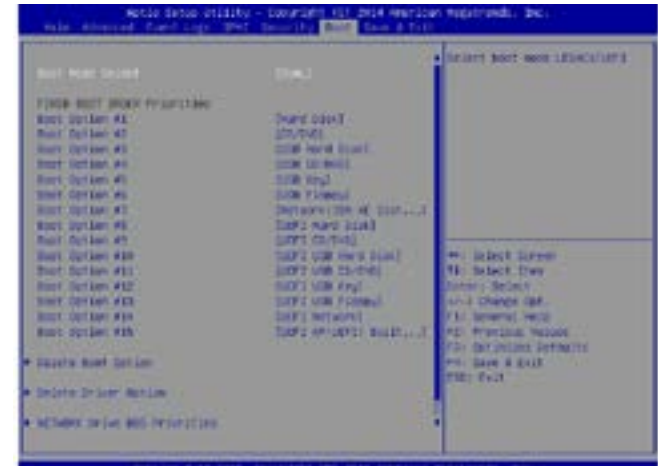

### Boot Configuration

#### Boot Mode Select

Use this item to select the type of device to be used for system boot. The options are Legacy, UEFI, and Dual.

#### Fixed Boot Order Priorities

This option prioritizes the order of bootable devices from which the system will boot. Press <Enter> on each entry from top to bottom to select devices.

When the item above -"Boot Mode Select" is set to **Dual** (default), the following items will be displayed for configuration:

- Boot Option #1 - Boot Option #15

When the item above -"Boot Mode Select" is set to Legacy, the following items will be display for configuration:

- Boot Option #1 - Boot Option #7

When the item above -"Boot Mode Select" is set to UEFI, the following items will be display for configuration:

- Boot Option #1 - Boot Option #8

#### ►Delete Boot Option

Use this item to select a boot device to delete from the boot priority list.

**Delete Boot Option**

Select the target boot device to delete from the boot priority list.

**►Delete Driver Option**

Use this item to select a driver to delete from the boot priority list.

**Delete Boot Option**

Select the target boot drive to delete from the boot priority list.

**►Hard Disk Drive BBS Priorities**

- Boot Option #1

**►Network Drive BBS Priorities**

- Boot Option #1

**►UEFI Application Boot Priorities**

- UEFI Boot Option #1

## 7-8 Save & Exit

This submenu allows the user to configure the following Save & Exit settings:

**Discard Changes and Exit**

Select this item to exit from the BIOS setup without making any permanent changes to the system configuration, and reboot the computer.

**Save Changes and Reset**

When you have completed the system configuration changes, select this item to leave the BIOS setup utility and reboot the computer for the new system configuration parameters to take effect. Select Yes and press <Enter> to save the changes you've made and reboot the system.

**Save Options****Save Changes**

When you have completed the system configuration changes, select this item to save all changes made. This will not reset (reboot) the system.

**Discard Changes**

Select this item to discard all the changes and return to the AMI BIOS setup utility. Select Yes and press <Enter> to discard all changes made.

**Restore Defaults**

Select this item and press <Enter> to load the manufacture default settings which are designed for maximum system performance but not for maximum stability.

**Save As User Defaults**

Select this item and press <Enter> to save the current BIOS settings as user's default settings for future use.

**Restore User Defaults**

Select this item and press <Enter> to retrieve the user-defined default settings that were previously saved to be used as current default settings.

**Boot Override**

This feature allows the user to override the boot priority sequence in the Boot submenu and immediately boot the system with another device specified by the user. This is a one-time override.

# Notes

## Appendix A

### BIOS Error Beep Codes

During the POST (Power-On Self-Test) routines, which are performed at each system boot, errors may occur.

**Non-fatal errors** are those which, in most cases, allow the system to continue to boot. The error messages normally appear on the screen.

**Fatal errors** will not allow the system to continue with bootup procedure. If a fatal error occurs, you should consult with your system manufacturer for possible repairs.

These fatal errors are usually communicated through a series of audible beeps. The numbers on the fatal error list correspond to the number of beeps for the corresponding error.

Motherboard BIOS Error Beep Codes		
Beep Code/LED	Error Message	Description
1 beep	Refresh	Ready to boot
5 short beeps + 1 long beep	Memory error	No memory detected in the system
5 beeps	No Con-In or No Con-Out devices	Con-In includes USB or PS/2 keyboard, PCI or Serial Console Redirection, IPMI KVM or SOL.  Con-Out includes Video Controller, PCI or Serial Console Redirection, IPMI SOL.
1 beep per device	Refresh	1 beep or each USB device detected

## Notes

## Appendix B

# System Specifications

### Processors

Single or dual Intel® Xeon E5-2600 (v3/v4) Series processors

Note: Please refer to our web site for a complete listing of supported processors.

### Chipset

Intel C612 chipset

### BIOS

128 Mb AMI® SPI Flash ROM

### Memory Capacity

Sixteen DIMM sockets supporting up to 2 TB of ECC LRDIMM (Load Reduced DIMM) or 1 TB of ECC RDIMM (Registered DIMM) DDR4-2400/2133/1866/1600 memory

Note: see Section 5-6 for details

### Drive Bays

Thirty-six hot-swap drive bays to house SAS or SATA drives (24 in front, 12 in rear)

### Expansion Slots

Up to five PCI-E expansion cards may be added to the system. Note that some PCI slots may not be enabled if only a single processor is installed (see Section 5-6).

### Serverboard

X10DRH-iT (Extended ATX form factor)

Dimensions: 13.68 x 13.05 in (347.5 x 331.5 mm)

**Chassis**

SC847BE1C-R1K28LPB, 4U rackmount

Dimensions: (WxHxD) 17.2 x 7 x 26 in. (437 x 178 x 660 mm)

**Weight**

Net: 78 lbs. (35.5 kg.)

Gross: 110 lbs. (220 kg.)

**System Cooling**

Four 8-cm system fans

Three 8-cm exhaust fans

One air shroud

**Power Supply**

Rated Output Power: 1280W (Part# PWS-1K28P-SQ)

Rated Output Voltages: 1000W: +12V (83A), +5Vsb (4A), 1280W: +12V (106.7A), +5Vsb (4A)

**System Input Requirements**

AC Input Voltage: 100 - 240V AC auto-range

Rated Input Current: 1000W output @ 100-140V: 12 - 8A, 1280W output @ 180-240V: 8 - 6A

Rated Input Frequency: 50 to 60 Hz

**Operating Environment**

Operating Temperature: 10° to 35° C (32° to 95° F)

Non-operating Temperature: -40° to 60° C (-40° to 140° F)

Operating Relative Humidity: 8% to 90% (non-condensing)

Non-operating Relative Humidity: 5% to 95% (non-condensing)

**Regulatory Compliance**

Electromagnetic Emissions: FCC Class A, EN 55022 Class A, EN 61000-3-2/-3-3, CISPR 22 Class A

Electromagnetic Immunity: EN 55024/CISPR 24, (EN 61000-4-2, EN 61000-4-3, EN 61000-4-4, EN 61000-4-5, EN 61000-4-6, EN 61000-4-8, EN 61000-4-11)

Safety: CSA/EN/IEC/UL 60950-1 Compliant, UL or CSA Listed (USA and Canada), CE Marking (Europe)

California Best Management Practices Regulations for Perchlorate Materials: This Perchlorate warning applies only to products containing CR (Manganese Dioxide) Lithium coin cells. "Perchlorate Material-special handling may apply. See [www.dtsc.ca.gov/hazardouswaste/perchlorate](http://www.dtsc.ca.gov/hazardouswaste/perchlorate)"

(continued from front)

The products sold by Supermicro are not intended for and will not be used in life support systems, medical equipment, nuclear facilities or systems, aircraft, aircraft devices, aircraft/emergency communication devices or other critical systems whose failure to perform be reasonably expected to result in significant injury or loss of life or catastrophic property damage. Accordingly, Supermicro disclaims any and all liability, and should buyer use or sell such products for use in such ultra-hazardous applications, it does so entirely at its own risk. Furthermore, buyer agrees to fully indemnify, defend and hold Supermicro harmless for and against any and all claims, demands, actions, litigation, and proceedings of any kind arising out of or related to such ultra-hazardous use or sale.