

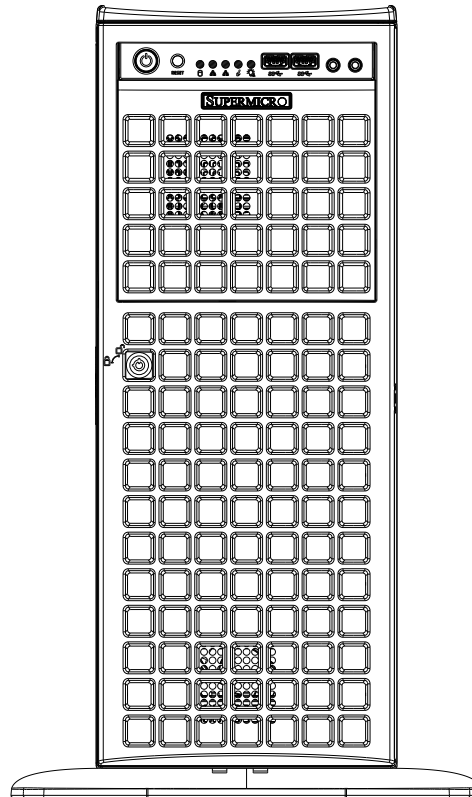

SuperWorkstation 7049GP-TRT



USER'S MANUAL

Revision 1.1

The information in this User's Manual has been carefully reviewed and is believed to be accurate. The vendor assumes no responsibility for any inaccuracies that may be contained in this document, and makes no commitment to update or to keep current the information in this manual, or to notify any person or organization of the updates. **Please Note: For the most up-to-date version of this manual, please see our website at www.supermicro.com.**

Super Micro Computer, Inc. ("Supermicro") reserves the right to make changes to the product described in this manual at any time and without notice. This product, including software and documentation, is the property of Supermicro and/or its licensors, and is supplied only under a license. Any use or reproduction of this product is not allowed, except as expressly permitted by the terms of said license.

IN NO EVENT WILL Super Micro Computer, Inc. BE LIABLE FOR DIRECT, INDIRECT, SPECIAL, INCIDENTAL, SPECULATIVE OR CONSEQUENTIAL DAMAGES ARISING FROM THE USE OR INABILITY TO USE THIS PRODUCT OR DOCUMENTATION, EVEN IF ADVISED OF THE POSSIBILITY OF SUCH DAMAGES. IN PARTICULAR, SUPER MICRO COMPUTER, INC. SHALL NOT HAVE LIABILITY FOR ANY HARDWARE, SOFTWARE, OR DATA STORED OR USED WITH THE PRODUCT, INCLUDING THE COSTS OF REPAIRING, REPLACING, INTEGRATING, INSTALLING OR RECOVERING SUCH HARDWARE, SOFTWARE, OR DATA.

Any disputes arising between manufacturer and customer shall be governed by the laws of Santa Clara County in the State of California, USA. The State of California, County of Santa Clara shall be the exclusive venue for the resolution of any such disputes. Supermicro's total liability for all claims will not exceed the price paid for the hardware product.

FCC Statement: This equipment has been tested and found to comply with the limits for a Class A digital device pursuant to Part 15 of the FCC Rules. These limits are designed to provide reasonable protection against harmful interference when the equipment is operated in an industrial environment. This equipment generates, uses, and can radiate radio frequency energy and, if not installed and used in accordance with the manufacturer's instruction manual, may cause harmful interference with radio communications. Operation of this equipment in a residential area is likely to cause harmful interference, in which case you will be required to correct the interference at your own expense.

California Best Management Practices Regulations for Perchlorate Materials: This Perchlorate warning applies only to products containing CR (Manganese Dioxide) Lithium coin cells. "Perchlorate Material-special handling may apply. See www.dtsc.ca.gov/hazardouswaste/perchlorate".



WARNING: This product can expose you to chemicals including lead, known to the State of California to cause cancer and birth defects or other reproductive harm. For more information, go to www.P65Warnings.ca.gov.

The products sold by Supermicro are not intended for and will not be used in life support systems, medical equipment, nuclear facilities or systems, aircraft, aircraft devices, aircraft/emergency communication devices or other critical systems whose failure to perform be reasonably expected to result in significant injury or loss of life or catastrophic property damage. Accordingly, Supermicro disclaims any and all liability, and should buyer use or sell such products for use in such ultra-hazardous applications, it does so entirely at its own risk. Furthermore, buyer agrees to fully indemnify, defend and hold Supermicro harmless for and against any and all claims, demands, actions, litigation, and proceedings of any kind arising out of or related to such ultra-hazardous use or sale.

Manual Revision 1.1

Release Date: February 02, 2021

Unless you request and receive written permission from Super Micro Computer, Inc., you may not copy any part of this document. Information in this document is subject to change without notice. Other products and companies referred to herein are trademarks or registered trademarks of their respective companies or mark holders.

Copyright © 2021 by Super Micro Computer, Inc.
All rights reserved.

Printed in the United States of America

Preface

About this Manual

This manual is written for professional system integrators and PC technicians. It provides information for the installation and use of the SuperWorkstation. Installation and maintenance should be performed by experienced technicians only.

Please refer to the server specifications page on our website for updates on supported memory, processors and operating systems (<http://www.supermicro.com>).

Notes

For your system to work properly, please follow the links below to download all necessary drivers/utilities and the user's manual for your server.

- Supermicro product manuals: <http://www.supermicro.com/support/manuals/>
- Product drivers and utilities: <https://www.supermicro.com/wdl/driver>
- Product safety info: http://www.supermicro.com/about/policies/safety_information.cfm

If you have any questions, please contact our support team at:
support@supermicro.com.

This manual may be periodically updated without notice. Please check the Supermicro website for possible updates to the manual revision level.

Secure Data Deletion

A secure data deletion tool designed to fully erase all data from storage devices can be found on our website: https://www.supermicro.com/about/policies/disclaimer.cfm?url=/wdl/utility/Lot9_Secure_Data_Deletion_Utility

Warnings

Special attention should be given to the following symbols used in this manual.



Warning! Indicates important information given to prevent equipment/property damage or personal injury.



Warning! Indicates high voltage may be encountered when performing a procedure.

Contents

Chapter 1 Introduction

1.1 Overview.....	8
1.2 Unpacking the System	8
1.3 System Features	9
1.4 Server Chassis Features.....	10
Control Panel	10
Front Features.....	12
Rear Features	13
1.5 Motherboard Layout	14
Quick Reference Table.....	15

Chapter 2 Workstation Setup

2.1 Overview.....	18
2.2 Preparing for Setup	18
General Precautions	18
Choosing a Setup Location.....	18
Workstation Precautions	19
Rack Precautions	19
Ambient Operating Temperature.....	19
Airflow	19
Mechanical Loading.....	19
Circuit Overloading	19
Reliable Ground.....	20
2.3 Preparing the Chassis for Rack Mounting	21
Removing the Top Tower Cover.....	21
Removing the Chassis Feet.....	21
2.4 Installing the Rails	22
Identifying the Sections of the Rack Rails	22
Installing the Inner Rails to the Chassis	23
Installing the Outer Rails to the Rack	24
2.5 Installing the Chassis into the Rack.....	25
Removing the Chassis from the Rack	26

Chapter 3 Maintenance and Component Installation

3.1 Removing Power	27
3.2 Accessing the System.....	27
3.3 Motherboard Components.....	28
Processor and Heatsink Installation.....	28
Overview of the Processor Socket Assembly	29
Overview of the Processor Heatsink Module (PHM)	30
Attaching the Non-F Model Processor to the Narrow Processor Clip to Create the Processor Package Assembly.....	31
Removing the FAN Module	32
Attaching the Non-F Model Processor Package Assembly to the Heatsink to Form the Processor Heatsink Module (PHM).....	33
Preparing the CPU Socket for Installation	34
Removing the Dust Cover from the CPU Socket	34
Installing the Processor Heatsink Module (PHM)	35
Removing the Processor Heatsink Module (PHM) from the Motherboard	36
Air Shroud	37
System Cooling	38
System Fan Failure	38
Replacing System Fans	38
Drive Carrier Indicators	40
3.4 Memory Support and Installation	41
DDR4 Memory Support for Intel Xeon Scalable-SP Processors.....	42
DDR4 Memory Support for 2nd Gen Intel Xeon Scalable-SP Processors.....	42
DIMM Population Guidelines for Optimal Performance	43
Key Parameters for DIMM Configuration	43
DIMM Population Table	44
Memory Population Table for the Motherboard Using Intel Xeon Scalable-SP and 2nd Gen Intel Xeon Scalable-SP Processors.....	44
DIMM Population Table	44
Memory Population Table for the Motherboard Using Intel Xeon Scalable-SP and 2nd Gen Intel Xeon Scalable-SP Processors.....	44
Installing Memory	45
Motherboard Battery	46

Chapter 4 Motherboard Connections

4.1 Power Connections	47
4.2 Headers and Connectors	48
4.3 Ports	54
Rear I/O Ports.....	54
4.4 Jumpers.....	57
Explanation of Jumpers	57
4.5 LED Indicators.....	60

Chapter 5 Software

5.1 Microsoft Windows OS Installation.....	61
5.2 Driver Installation.....	63
5.3 SuperDoctor® 5.....	64
5.4 IPMI	65
BMC ADMIN User Password	65

Chapter 6 UEFI BIOS

6.1 Introduction.....	66
Starting the Setup Utility	66
6.2 Main Setup	67
6.3 Advanced Setup Configurations.....	68
6.4 Event Logs	102
6.5 IPMI	104
6.6 Security.....	107
6.7 Boot.....	110
6.8 Save & Exit.....	113

Appendix A BIOS Error Codes

Appendix B Standardized Warning Statements for AC Systems

Appendix C System Specifications

Appendix D UEFI BIOS Recovery

Appendix E BSMI RoHS

Contacting Supermicro

Headquarters

Address: Super Micro Computer, Inc.
980 Rock Ave.
San Jose, CA 95131 U.S.A.

Tel: +1 (408) 503-8000

Fax: +1 (408) 503-8008

Email: marketing@supermicro.com (General Information)
support@supermicro.com (Technical Support)

Website: www.supermicro.com

Europe

Address: Super Micro Computer B.V.
Het Sterrenbeeld 28, 5215 ML
's-Hertogenbosch, The Netherlands

Tel: +31 (0) 73-6400390

Fax: +31 (0) 73-6416525

Email: sales@supermicro.nl (General Information)
support@supermicro.nl (Technical Support)
rma@supermicro.nl (Customer Support)

Website: www.supermicro.nl

Asia-Pacific

Address: Super Micro Computer, Inc.
3F, No. 150, Jian 1st Rd.
Zhonghe Dist., New Taipei City 235
Taiwan (R.O.C)

Tel: +886-(2) 8226-3990

Fax: +886-(2) 8226-3992

Email: support@supermicro.com.tw

Website: www.supermicro.com.tw

Chapter 1

Introduction

1.1 Overview

This chapter provides a brief outline of the functions and features of the 7049GP-TRT. The 7049GP-TRT is based on the X11DPG-QT motherboard and the SC-747BTS-R2K20BP chassis.

In addition to the motherboard and chassis, several important parts that are included with the system are listed below.

Main Parts List		
Description	Part Number	Quantity
Hybrid backplane	BPN-SAS3-747TQ-N4	1
iPASS to 2 SATA cable	CBL-0188L-02	2
Active CPU heatsink	SNK-P0070APS4	2
4-pin PWM fan	Fan-0114L4	2
Middle fan	FAN-0138L4	2
4-pin PWM fan assembly	FAN-0082L4	2

1.2 Unpacking the System

Inspect the box the SuperServer 7049GP-TRT was shipped in and note if it was damaged in any way. If any equipment appears damaged, please file a damage claim with the carrier who delivered it.

Decide on a suitable location for the rack unit that will hold the server. It should be situated in a clean, dust-free area that is well ventilated. Avoid areas where heat, electrical noise and electromagnetic fields are generated. It will also require a grounded AC power outlet nearby. Be sure to read the precautions and considerations noted in Appendix B.

1.3 System Features

The following table provides you with an overview of the main features of the 7049GP-TRT. Please refer to Appendix C for additional specifications.

System Features
Motherboard
X11DPG-QT
Chassis
SC-747BTS-R2K20BP
CPU
Dual Intel Xeon Scalable-SP and 2nd Gen Intel Xeon Scalable-SP processors (Socket P) with three Intel® UltraPath Interconnect (UPI) links of up to 10.4 GT/s
Socket Type
Dual Socket P (LGA 3647)
Memory
Integrated memory controller embedded in the processor supports up to 4TB of 3DS Load Reduced DIMM (3DS LRDIMM), 3DS Registered DIMM (3DS RDIMM), or up to 2TB of Load Registered DIMM (LRDIMM), with speeds of 2933*/2666/2400/2133/1866/1600/1333 MHz modules in 16 memory slots. Note: 2933 MHz memory is supported by 2nd Gen Intel Scalable-SP (82xx/62xx series) processors only.
Chipset
Intel® C621 chipset
Expansion Slots
Four PCI Express 3.0 x16 Two PCI Express 3.0 x16 or HSSI (High Speed Serial Interface) One PCI Express 3.0 x4 in x8 slot
Hard Drives
Eight hot-swap 3.5" drives
Power
1+1 redundant and hot-swappable 2200W power supplies with PMBus
Form Factor
4U Rackmount/Tower
Dimensions
7.0 x 18.2 x 26.5 in. / 178 x 462 x 673 mm. (W x H x D)

1.4 Server Chassis Features

Control Panel

The switches and LEDs located on the control panel are described below. See Chapter 4 for details on the control panel connections.

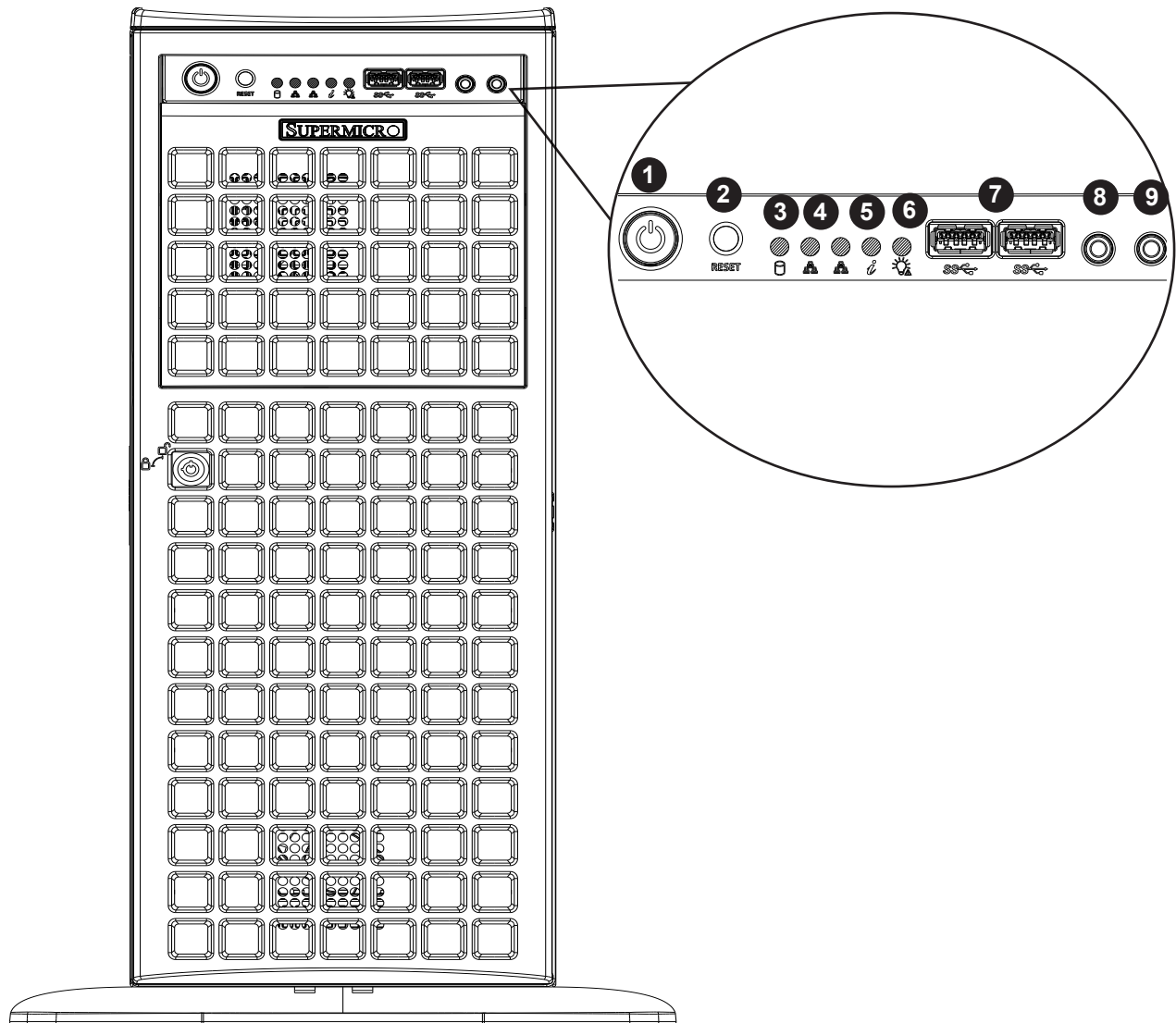

Figure 1-1. Control Panel View

Control Panel Features		
Item	Feature	Description
1	Power Button	The main power switch is used to apply or remove power from the power supply to the server. Turning off system power with this button removes the main power but maintains standby power. To perform many maintenance tasks, you must unplug system before servicing.
2	Reset Button	The reset button is used to reboot the system.
3	HDD LED	Indicates hard drive activity on the hard drive when flashing.
4	NIC LED	Indicates network activity on LAN when flashing.
5	Information LED	Alerts operator of several states. See table below for details.
6	Power Fail	Indicates a power failure to the system's power supply units.
7	USB3.0	Two USB 3.0 ports.
8	Line out	Line out port.
9	Mic	Mic port.

Information LED	
Status	Description
Continuously on and red	An overheat condition has occurred. (This may be caused by cable congestion.)
Blinking red (1 Hz)	Fan failure, check for an inoperative fan.
Blinking red (0.25 Hz)	Power failure, check for a non-operational power supply.
Solid blue	Local UID has been activated. Use this function to locate the server in a rack mount environment.
Blinking blue	Remote UID is on. Use this function to identify the server from a remote location.

Front Features

The SC-747BTS-R2K20BP is 4U rackmount/tower chassis. See the illustration below for the features included on the front of the chassis.

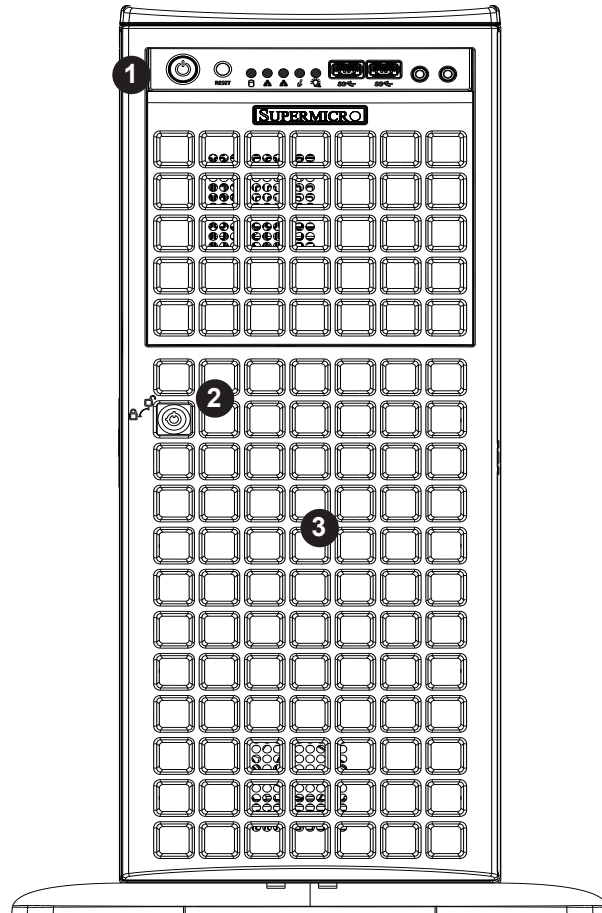

Figure 1-2. Chassis Front View

Front Chassis Features		
Item	Feature	Description
1	Control Panel	Front control panel (see preceding page).
2	Bezel Lock (Optional)	Locks the bezel for secure access.
3	Hot-swap Drive Bays	Eight 3.5" drive bays.

Rear Features

The illustration below shows the features included on the rear of the chassis.

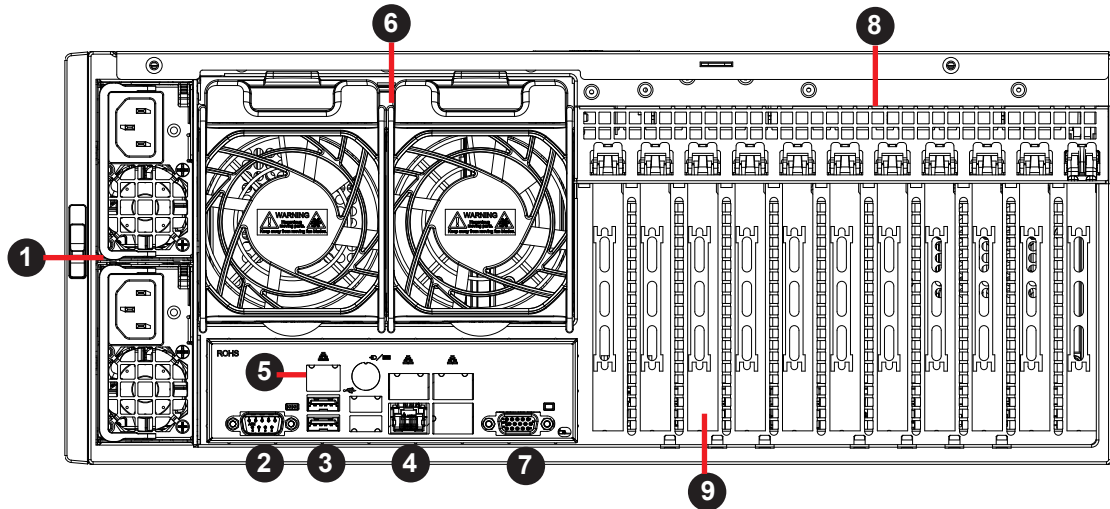

Figure 1-3. Chassis Rear View

Rear Chassis Features		
Item	Feature	Description
1	Power	Two 2200W redundant power supplies with PMBus
2	COM	Serial Port
3	USB	Two USB 3.0 ports and two USB 2.0 ports
4	LAN	Two RJ45 10GBase-T ports
5	IPMI	RJ45 Dedicated IPMI LAN port
6	FAN	Two rear fans
7	Video	VGA port
8	PCIe	Four PCIe 3.0 x16 (double-width) slots
9	PCIe	Two PCIe 3.0 x16 (single-width) slots and one PCIe 3.0 x4 (in x8) slot

1.5 Motherboard Layout

Below is a layout of the X11DPG-QT with jumper, connector and LED locations shown. See the table on the following page for descriptions. For detailed descriptions, pinout information and jumper settings, refer to Chapter 4.

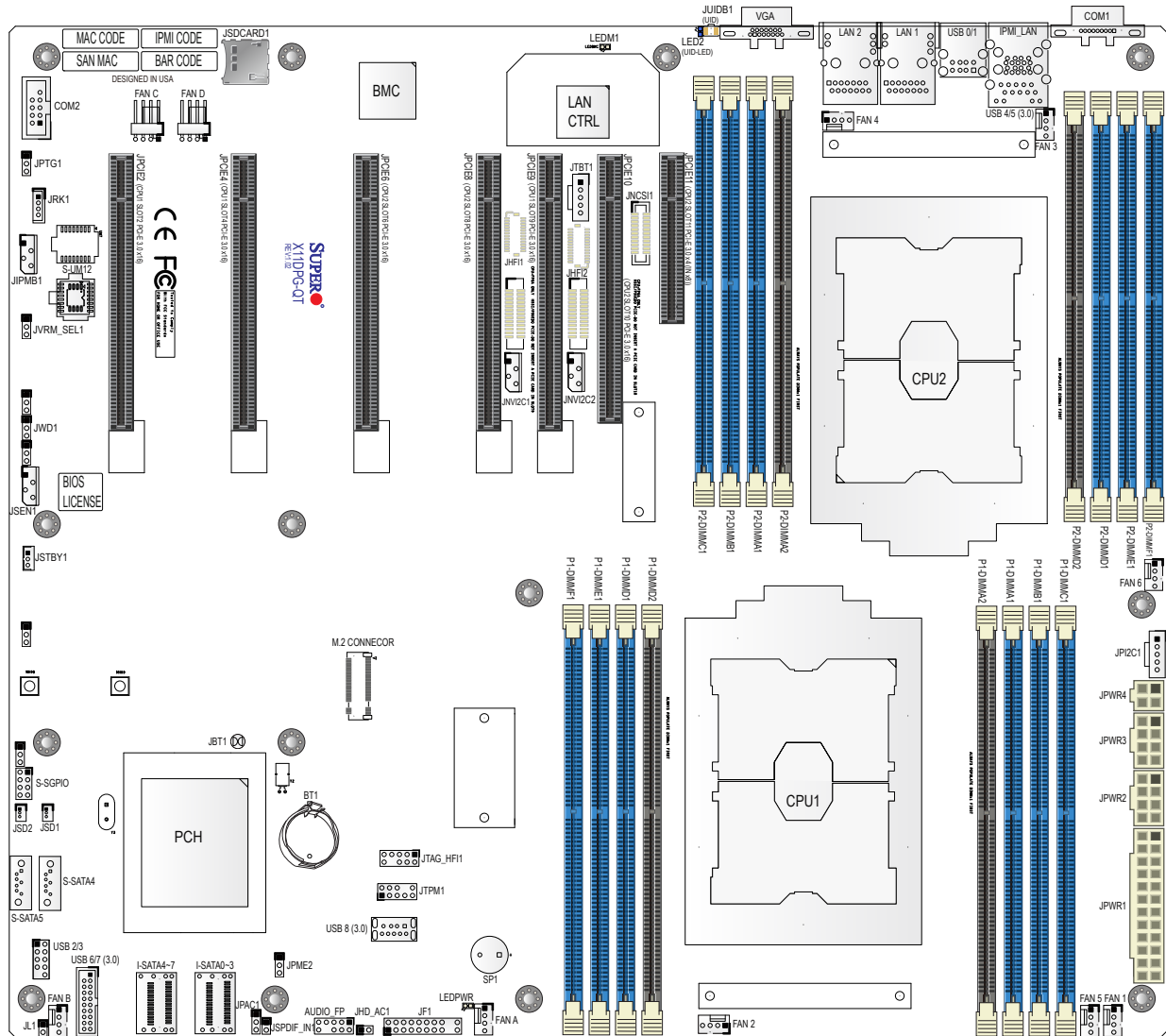

Figure 1-4. Motherboard Layout

Quick Reference Table

Jumper	Description	Default Setting
JBT1	CMOS Clear	Open (Normal)
JHD_AC1	AC97/High Definition Audio Enable	Off (HD Enabled)
JPAC1	Audio Enable	Pins 1-2 (Enabled)
JPME2	ME Manufacturing Mode	Pins 1-2 (Normal)
JPTG1	Onboard 10Gb LAN1/2 Enable/Disable	Pins 1-2 (Enabled)
JVRM_SEL1	VRM_I2C Jumper	Pins 1-2 (Normal)
JWD1	Watch Dog Timer Reset	Pins 1-2 (Reset)

Connector	Description
AUDIO_FP	Front Panel Audio Header
BT1	Onboard Battery
COM1	COM Port (COM1) on the I/O Backplane
COM2	COM Header
FAN1 ~ FAN6, FANA, FANB, FANC, FAND	System/CPU Fan Headers (FAN5: CPU1 Fan, FAN6: CPU2 Fan)
IPMI_LAN	Dedicated IPMI LAN Port
I-SATA0~3, I-SATA4~7	Intel® PCH SATA 3.0 Ports (0-3, 4-7)
JF1	Front Control Panel Header
JIPMB1	4-pin BMC External IC Header (for an IPMI card)
JL1	Chassis Intrusion Header
JNCSI1	NC-SI Header for IPMI Support
JNVI2C1	VPP Header for the NVMe Add-on Card on PCIe Slot 9
JNVI2C2	VPP Header for the NVMe Add-on Card on PCIe Slot 10
JPI2C1	Power Supply SMBus I ² C Header
JPWR1	24-pin ATX Power Connector
JPWR2/JPWR3	12V 8-pin CPU Power Connector (To provide alternative power for special enclosure when the 24-pin ATX power is not in use.)
JPWR4	12V 4-pin Power Connectors
JRK1	RAID_Key for Onboard SATA Devices
JSD1/JSD2	SATA DOM Power Connectors 1/2
JSDCARD1	Micro SD Card Slot
JSEN1	Inlet Sensor Header
JSPDIF_IN1	Sony/Philips Digital Interface Audio Input Header

Connector	Description
JSTBY1	Standby Power Connector
JTAG_HFI1	HFI Debug Port for Fabric CPU
JTBT1	General Purpose Header for Thunderbolt Add-on Card
JTPM1	Trusted Platform Module/Port 80 connector
JUIDB1	UID (Unit Identifier) Switch
LAN1/2	LAN Ports
M.2 CONNECTOR	PCIe M.2 Connector, small form factor devices and other portable devices for High speed NVMe SSDs
S-SATA4/S-SATA5	SATA 3.0 Ports with Power-pin Built-in w/support of SuperDOM (Device-On Module)
S-SGPIO	Serial Link General Purpose I/O Header
SP1	Internal Speaker/Buzzer
USB 0/1	Back Panel USB 2.0 Ports
USB 2/3	Front Access USB 2.0 Header
USB 4/5	Back Panel USB 3.0 Ports
USB 6/7	Front Access USB 3.0 Header
USB 8	USB 3.0 Type A Header
VGA	VGA Port (Back Panel)

LED	Description	Status
LED2	UID (Unit Identifier) LED	Solid Blue: Unit Identified
LEDM1	BMC Heartbeat LED	Blinking Green: BMC Normal
LEDPWR	Onboard Power LED	Solid Green: Power On

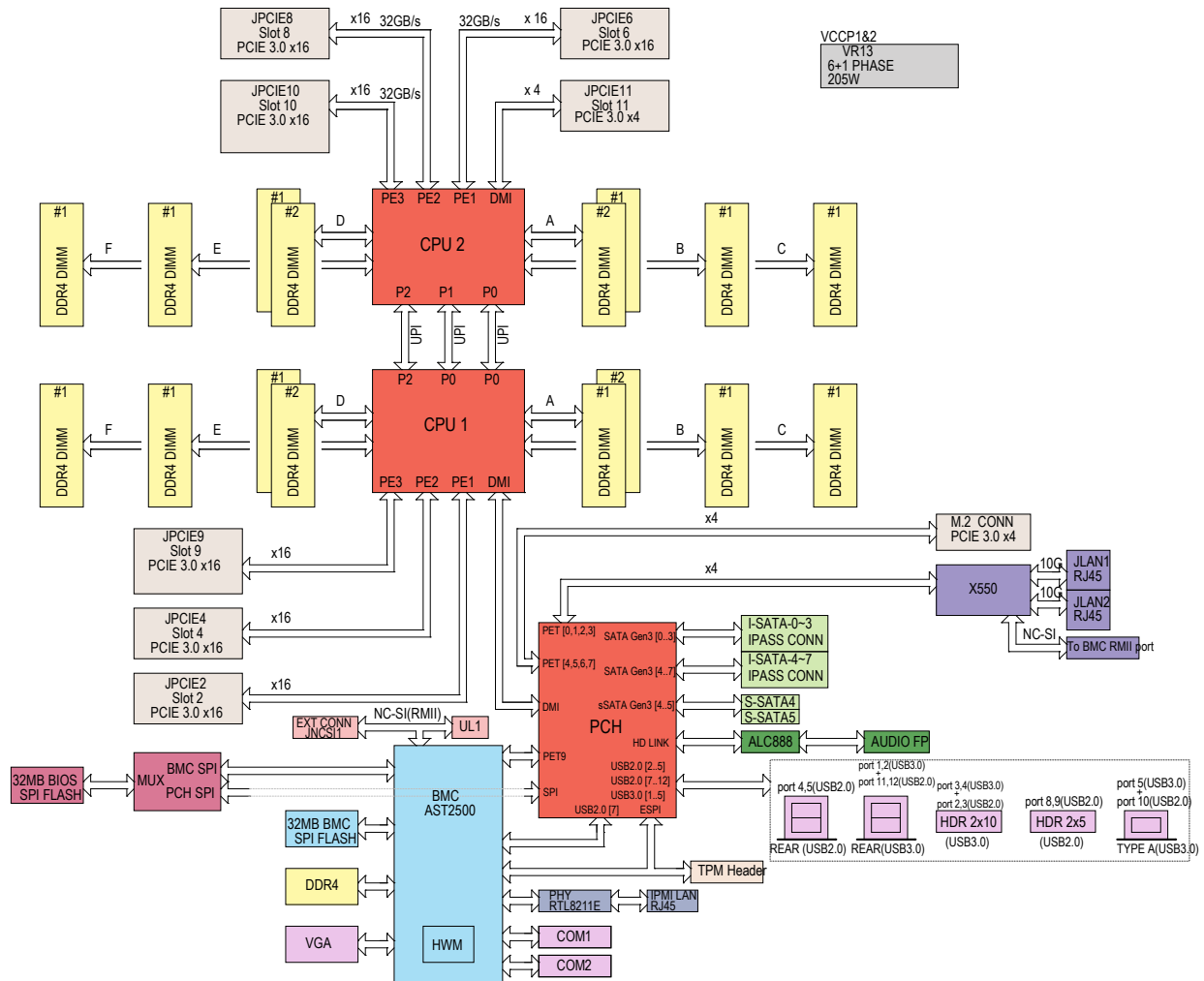

Figure 1-5. Intel® C621 Chipset: System Block Diagram

Note: This is a general block diagram and may not exactly represent the features on your motherboard. See the System Specifications appendix for the actual specifications of your motherboard.

Chapter 2

Workstation Setup

2.1 Overview

This chapter provides advice setting up your system. If your system is not already fully integrated with processors, system memory etc., refer to Chapter 3 for details on installing those specific components.

Caution: Electrostatic Discharge (ESD) can damage electronic components. To prevent such damage to PCBs (printed circuit boards), it is important to use a grounded wrist strap, handle all PCBs by their edges and keep them in anti-static bags when not in use.

2.2 Preparing for Setup

Please read this section in its entirety before you begin the installation.

General Precautions

- Review the electrical and general safety precautions in Appendix B.
- Use a regulating uninterruptible power supply (UPS) to protect the server from power surges and voltage spikes and to keep your system operating in case of a power failure.
- Allow any drives and power supply modules to cool before touching them.
- To maintain proper cooling, always keep all chassis panels closed and all SATA carriers installed when not being serviced.

Choosing a Setup Location

- The system should be situated in a clean, dust-free area that is well ventilated. Avoid areas where heat, electrical noise and electromagnetic fields are generated.
- Leave enough clearance in front and back of the system to allow sufficient airflow and access when servicing.
- This product should be installed only in a Restricted Access Location (dedicated equipment rooms, service closets, etc.).

- This product is not suitable for use with visual display workplace devices according to §2 of the German Ordinance for Work with Visual Display Units.

Workstation Precautions

- Ensure that the caster wheels on the workstation are locked.

Rack Precautions

- Ensure that the leveling jacks on the bottom of the rack are extended to the floor so that the full weight of the rack rests on them.
- In single rack installations, stabilizers should be attached to the rack. In multiple rack installations, the racks should be coupled together.
- Always make sure the rack is stable before extending a server or other component from the rack.
- You should extend only one server or component at a time - extending two or more simultaneously may cause the rack to become unstable.

• Rack Mounting Considerations

Ambient Operating Temperature

If installed in a closed or multi-unit rack assembly, the ambient operating temperature of the rack environment may be greater than the room's ambient temperature. Therefore, consideration should be given to installing the equipment in an environment compatible with the manufacturer's maximum rated ambient temperature (TMRA).

Airflow

Equipment should be mounted into a rack so that the amount of airflow required for safe operation is not compromised.

Mechanical Loading

Equipment should be mounted into a rack so that a hazardous condition does not arise due to uneven mechanical loading.

Circuit Overloading

Consideration should be given to the connection of the equipment to the power supply circuitry and the effect that any possible overloading of circuits might have on overcurrent protection

and power supply wiring. Appropriate consideration of equipment nameplate ratings should be used when addressing this concern.

Reliable Ground

A reliable ground must be maintained at all times. To ensure this, the rack itself should be grounded. Particular attention should be given to power supply connections other than the direct connections to the branch circuit (i.e. the use of power strips, etc.).



To prevent bodily injury when mounting or servicing this unit in a rack, you must take special precautions to ensure that the system remains stable. The following guidelines are provided to ensure your safety:

- This unit should be mounted at the bottom of the rack if it is the only unit in the rack.
- When mounting this unit in a partially filled rack, load the rack from the bottom to the top with the heaviest component at the bottom of the rack.
- If the rack is provided with stabilizing devices, install the stabilizers before mounting or servicing the unit in the rack.



Slide rail mounted equipment is not to be used as a shelf or a work space.



Warning: Do not pick up the server with the front handles. They are designed to pull the system from a rack only.

2.3 Preparing the Chassis for Rack Mounting

The chassis top tower cover and feet must be removed before rack installation.

Removing the Top Tower Cover

1. Locate the blue cover lock at the rear of the cover.
2. Slide the lock to the right and push the cover forward.
3. Lift the top cover off the chassis.

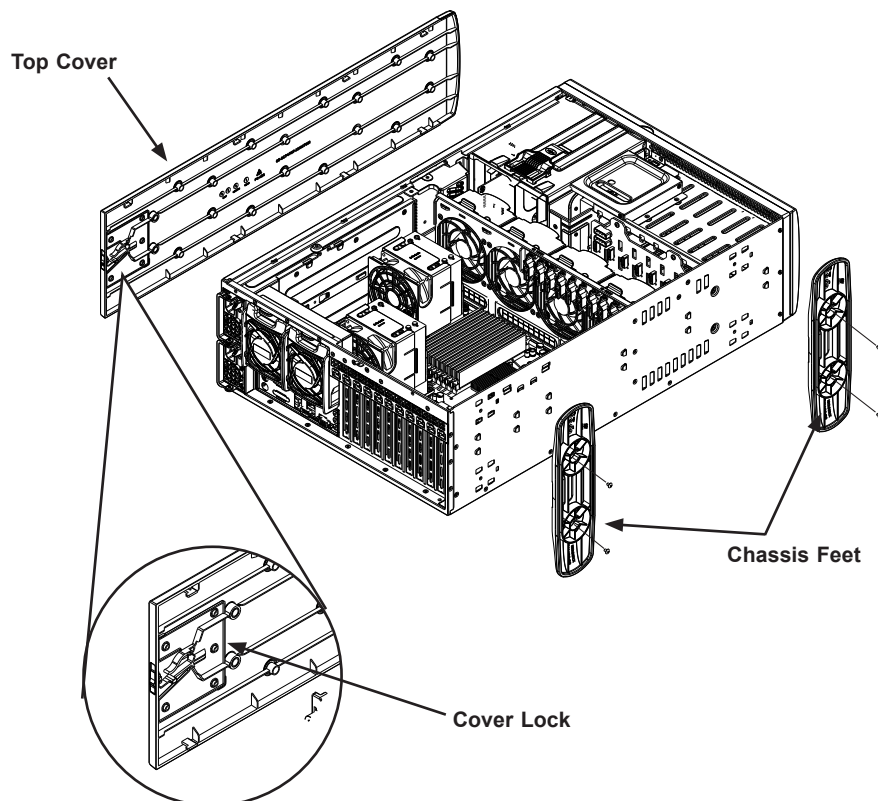

Figure 2-1. Removing the Top Tower Cover and Feet

Removing the Chassis Feet

1. Lay the chassis on its side.
2. Remove the screws holding the chassis feet in place.
3. Each foot has a foot lock tab at the center. Use a flat head screwdriver to gently lift the foot lock upward. Slide the foot toward the rear of the chassis.

2.4 Installing the Rails

This section provides a guideline for installing the rails to the chassis and to the rack with the optional rack mount kit.

Identifying the Sections of the Rack Rails

The chassis package includes two optional rack rail assemblies in the rack mounting kit. Each assembly consists of two sections: An inner fixed chassis rail that secures directly to the server chassis and an outer fixed rack rail that secures directly to the rack itself.

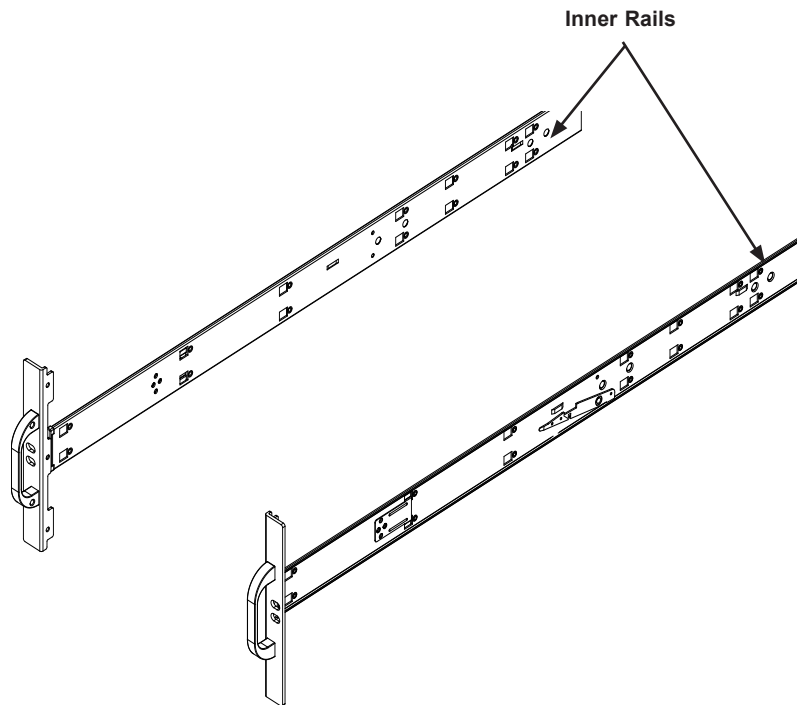

Figure 2-2. Identifying the Inner Rails and Chassis Handles

Installing the Inner Rails to the Chassis

1. Attach the handles to the front of the chassis with three screws each.
2. Identify the left and right inner rails. They are labeled on the rails and in the figure below.
3. Align each rail with the screw holes along the side of the chassis.
4. Screw the rails securely to the side of the chassis.

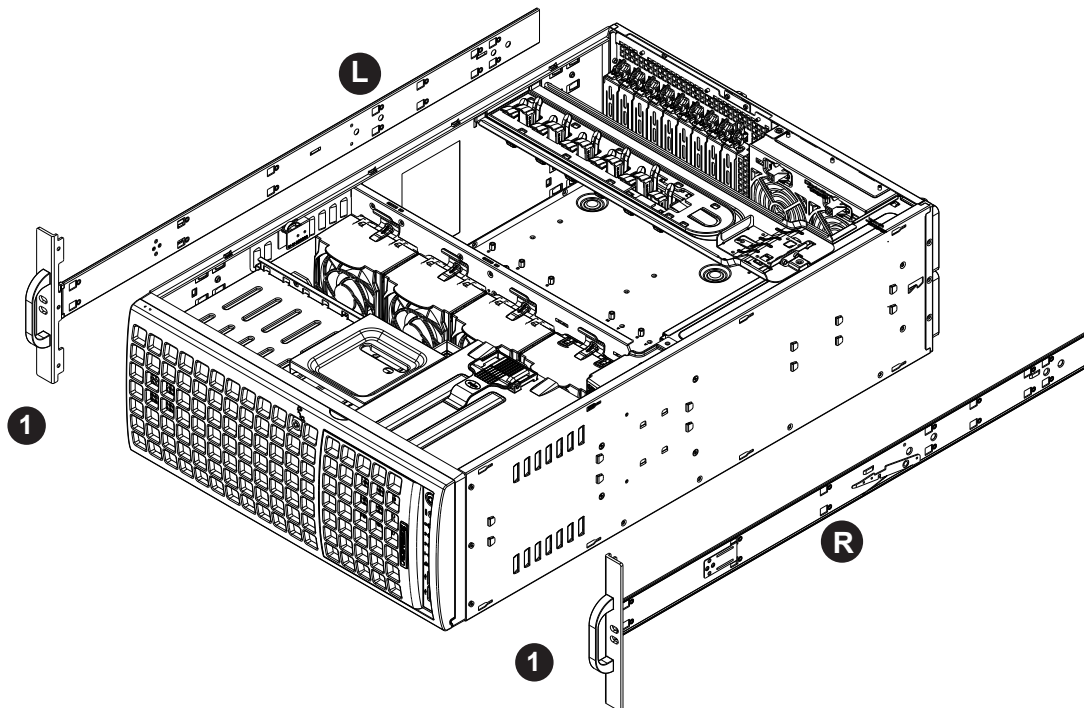

Figure 2-3. Installing the Handles and Inner Rails to the Chassis

Installing the Outer Rails to the Rack

Installing the Outer Rails

1. Attach the rear rail to the middle rail.
2. Adjust both to the proper distance so that the rails fit snugly into the rack.
3. Secure the rear rail with two M5 screws at the rear of the rack.
4. Repeat steps 1-3 for the left outer rail.

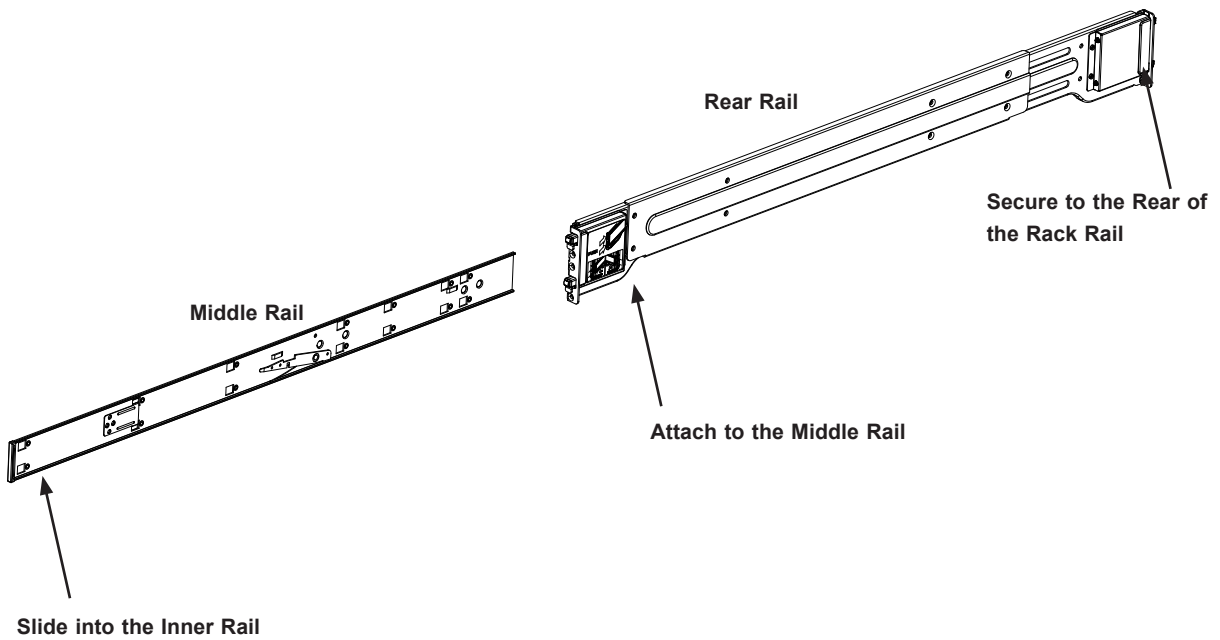

Figure 2-4. Inner and Outer Rack Rail Sections

2.5 Installing the Chassis into the Rack

With rails attached to both the chassis and the rack, install the system into the rack.

1. Confirm that the chassis includes the inner rails and the outer rails.
2. Align the inner chassis rails with the front of the outer rack rails.
3. Slide the inner rails into the outer rails, keeping the pressure even on both sides (you may have to depress the locking tabs when inserting). When the chassis has been pushed completely into the rack, you should hear the locking tabs "click" into the locked position.

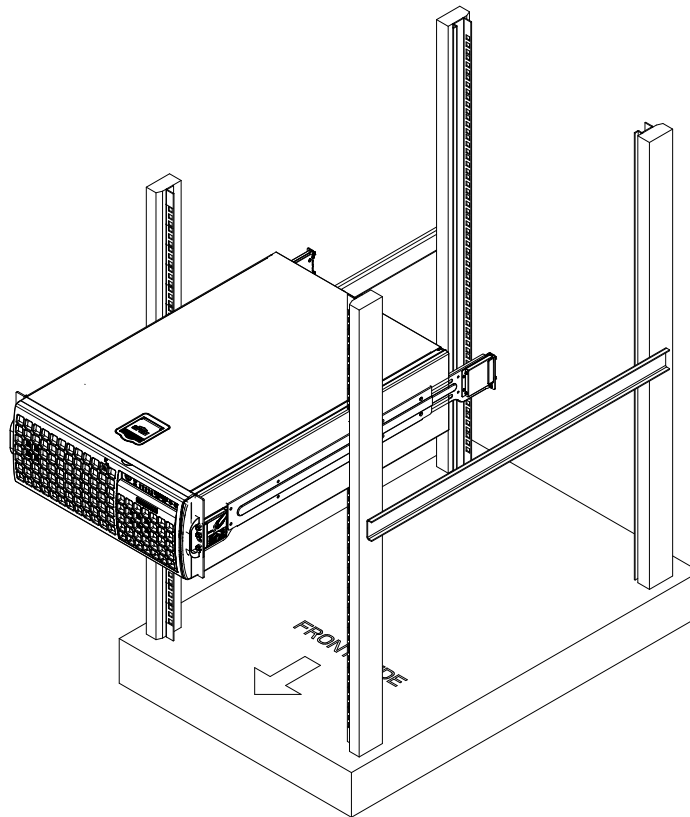

Figure 2-5. Installing the Server into the Rack

Note: The figure is for illustrative purposes only. Always install servers to the bottom of a rack first.



Warning: Stability hazard. The rack stabilizing mechanism must be in place, or the rack must be bolted to the floor before you slide the unit out for servicing. Failure to stabilize the rack can cause the rack to tip over.



When initially installing the system to a rack, test that the rail locking tabs engage to prevent the system from being overextended. Have a rack lift in place as a precaution in case the test fails.

Removing the Chassis from the Rack

Caution! It is dangerous for a single person to off-load the heavy chassis from the rack without assistance. Be sure to have sufficient assistance supporting the chassis when removing it from the rack. Use a lift.

1. Remove the screws that hold the front of the server to the rack.
2. Pull the chassis forward out the front of the rack until it stops.
3. Find the quick-release tab on each side of the chassis on the inner rails. Press down on the quick-release tab and continue to pull the chassis out of the rack.



Warning: In any instance of pulling the system from the rack, always use a rack lift and follow all associated safety precautions.



Slide rail mounted equipment is not to be used as a shelf or a work space.

Chapter 3

Maintenance and Component Installation

This chapter provides instructions on installing and replacing main system components. To prevent compatibility issues, only use components that match the specifications and/or part numbers given.

Installation or replacement of most components require that power first be removed from the system. Please follow the procedures given in each section.

3.1 Removing Power

Use the following procedure to ensure that power has been removed from the system. This step is necessary when removing or installing non hot-swap components or when replacing a non-redundant power supply.

1. Use the operating system to power down the system.
2. After the system has completely shut-down, disconnect the AC power cords from the power strip or outlet.
3. Disconnect the power cords from the power supply modules.

3.2 Accessing the System

The SC747BTS-R2K20BP chassis features two removable side covers, allowing access to the interior.

Removing the Side Covers

1. Remove the two screws securing the left side cover to the chassis.
2. Slide the left cover toward the rear of the chassis.
3. Lift the left cover from the chassis.
4. Remove the three screws securing the right side cover to the chassis.
5. Slide the right cover toward the rear of the chassis.
6. Insert the expansion (add-on) card into the riser card.

Caution: Except for short periods of time, do not operate the server without the cover in place. The chassis cover must be in place to allow for proper airflow and to prevent overheating.

3.3 Motherboard Components

Processor and Heatsink Installation

Follow the procedures in this section to install a processor (CPU) and heatsink onto the motherboard mounted in the chassis.

Warning: When handling the processor package, avoid placing direct pressure on the label area of the CPU or CPU socket. Also, improper CPU installation or socket misalignment can cause serious damage to the CPU or motherboard which may result in RMA repairs. Please read and follow all instructions thoroughly before installing your CPU and heatsink.

Notes:

- When receiving a motherboard without a processor pre-installed, make sure that the plastic protective socket cover is in place and none of the socket pins are bent; otherwise, contact your retailer immediately.
- Use an Intel-certified multi-directional heatsink.
- Refer to the Supermicro website for updates on CPU support.
- Always connect the power cord last, and always remove it before adding, removing, or changing any hardware components. Please note that the processor and heatsink should be assembled together first to form the Processor Heatsink Module (PHM), and then install the entire PHM into the CPU socket.

Note: All graphics, drawings, and pictures shown in this manual are for illustration only. The components that came with your machine may or may not look exactly the same as those shown in this manual.

Overview of the Processor Socket Assembly

The processor socket assembly contains 1) the Intel 82xx/62xx/52xx/42xx/32xx or 81xx/61xx/51xx/41xx/31xx processor, 2) the narrow processor clip, 3) the dust cover, and 4) the CPU socket.

1. The Processor

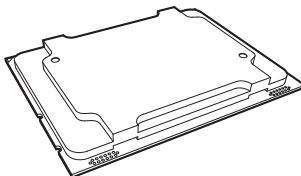

2. Narrow Processor Clip (the plastic processor package carrier used for the CPU)

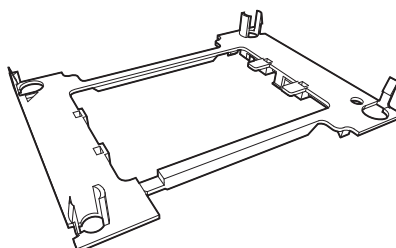

(for the non-F Model)

3. Dust Cover

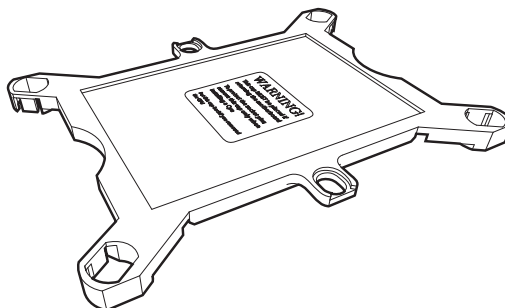

4. CPU Socket

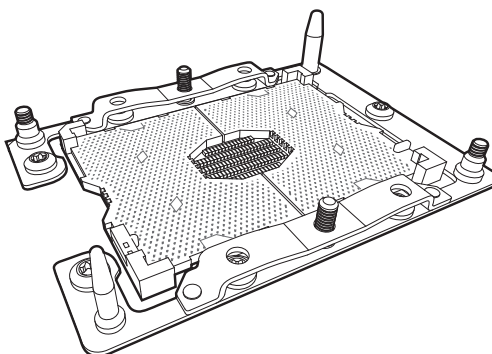

Note: Be sure to cover the CPU socket with the dust cover when the CPU is not installed.

Overview of the Processor Heatsink Module (PHM)

The Processor Heatsink Module (PHM) contains 1) a heatsink, 2) a narrow processor clip, and 3) the Intel 82xx/62xx/52xx/42xx or 81xx/61xx/51xx/41xx/31xx processor.

1. Heatsink

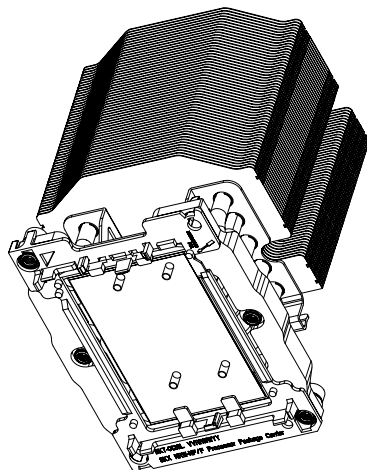

2. Narrow Processor Clip

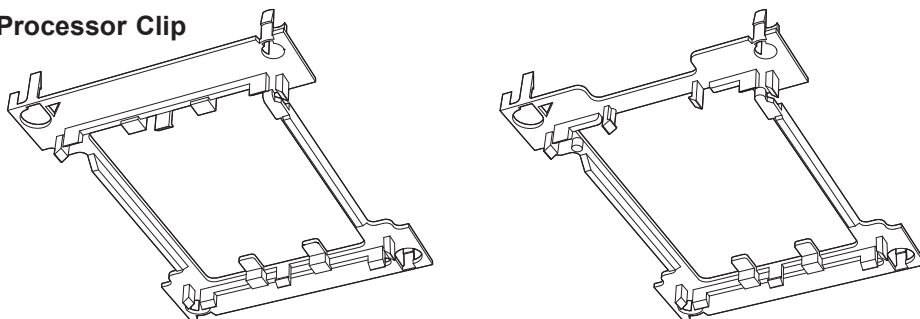

3. Intel Processor

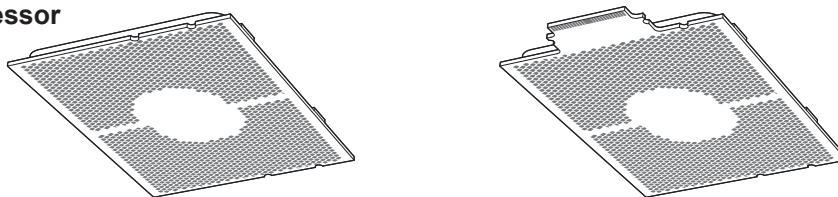

Attaching the Non-F Model Processor to the Narrow Processor Clip to Create the Processor Package Assembly

To properly install the CPU into the narrow processor clip, please follow the steps below.

1. Locate pin 1 (notch A), which is the triangle located on the top of the narrow processor clip. Also locate notch B and notch C on the processor clip.
2. Locate pin 1 (notch A), which is the triangle on the substrate of the CPU. Also, locate notch B and notch C on the CPU as shown below.
3. Align pin 1 (the triangle on the substrate) of the CPU with pin 1 (the triangle) of the narrow processor clip. Once they are aligned, carefully insert the CPU into the processor clip by sliding notch B of the CPU into notch B of the processor clip, and sliding notch C of the CPU into notch C of the processor clip.
4. Examine all corners of the CPU to ensure that it is properly seated on the processor clip. Once the CPU is securely attached to the processor clip, the processor package assembly is created.

Note: Please exercise extreme caution when handling the CPU. Do not touch the CPU LGA-lands to avoid damaging the LGA-lands or the CPU. Be sure to wear ESD gloves when handling components.

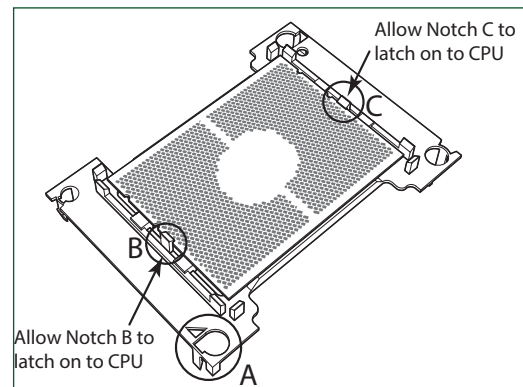
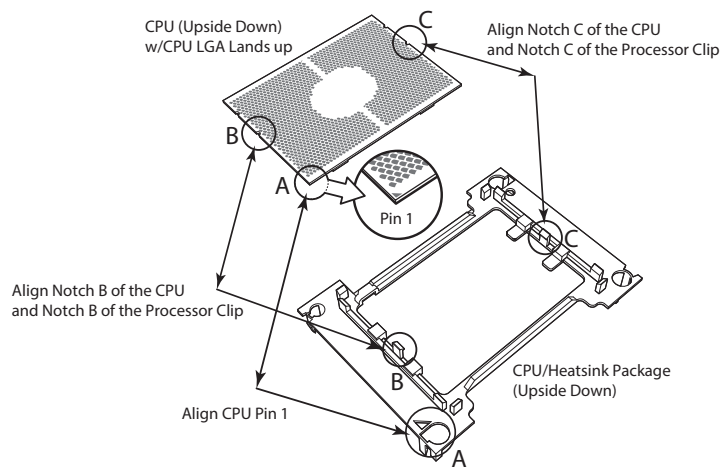

Processor Package Carrier (w/CPU mounted on the Processor Clip)

Removing the FAN Module

1. Unplug the fan module connector from the motherboard fan connector.
2. Remove the screw on the fan module to release it from the heatsink.

Attaching the Non-F Model Processor Package Assembly to the Heatsink to Form the Processor Heatsink Module (PHM)

After you have made a processor package assembly by following the instructions on the previous page, please follow the steps below to mount the processor package assembly onto the heatsink to create the Processor Heatsink Module (PHM).

1. Locate "CPU 1" on the heatsink label and the triangular corner next to it on the heatsink. With your index finger pressing against the screw at this triangular corner, carefully hold and turn the heatsink upside down with the thermal-grease side facing up. Remove the protective thermal film if present, and apply the proper amount of the thermal grease as needed. (Skip this step if you have a new heatsink because the necessary thermal grease is pre-applied in the factory.)
2. Holding the processor package assembly at the center edge, turn it upside down. With the thermal-grease side facing up, locate the hollow triangle located at the corner of the processor carrier assembly ("a" in the graphic). Note a larger hole and plastic mounting clicks located next to the hollow triangle. Also locate another set of mounting clicks and a larger hole at the diagonal corner of the same (reverse) side of the processor carrier assembly ("b" in the graphic).
3. With the back of heatsink and the reverse side of the processor package assembly facing up, align the triangular corner on the heatsink ("A" in the graphic) against the mounting clips next to the hollow triangle ("a") on the processor package assembly.
4. Also align the triangular corner ("B") at the diagonal side of the heatsink with the corresponding clips on the processor package assembly ("b").
5. Once the mounting clips on the processor package assembly are properly aligned with the corresponding holes on the back of heatsink, securely attach the heatsink to the processor package assembly by snapping the mounting clips at the proper places on the heatsink to create the processor heatsink module (PHM).

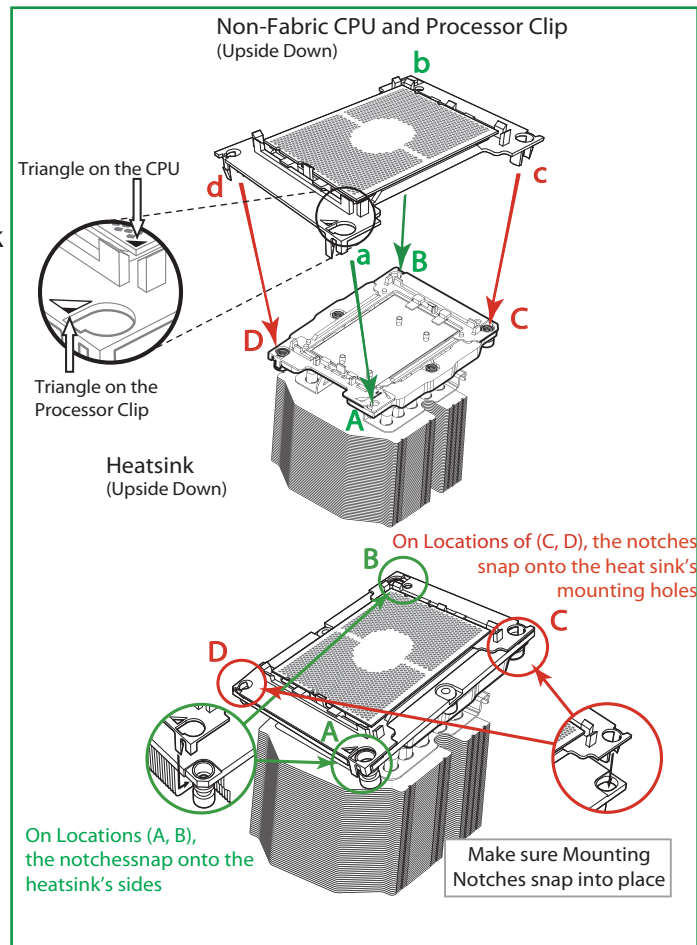

Preparing the CPU Socket for Installation

This motherboard comes with the CPU socket pre-assembled in the factory. The CPU socket contains 1) a dust cover, 2) a socket bracket, 3) the CPU (P0) socket, and 4) a back plate. These components are pre-installed on the motherboard before shipping.

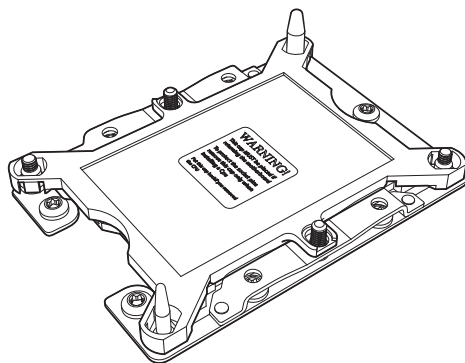

CPU Socket w/Dust Cover On

Removing the Dust Cover from the CPU Socket

Remove the dust cover from the CPU socket, exposing the CPU socket and socket pins as shown on the illustration below.

Note: Do not touch the socket pins to avoid damaging them, causing the CPU to malfunction.

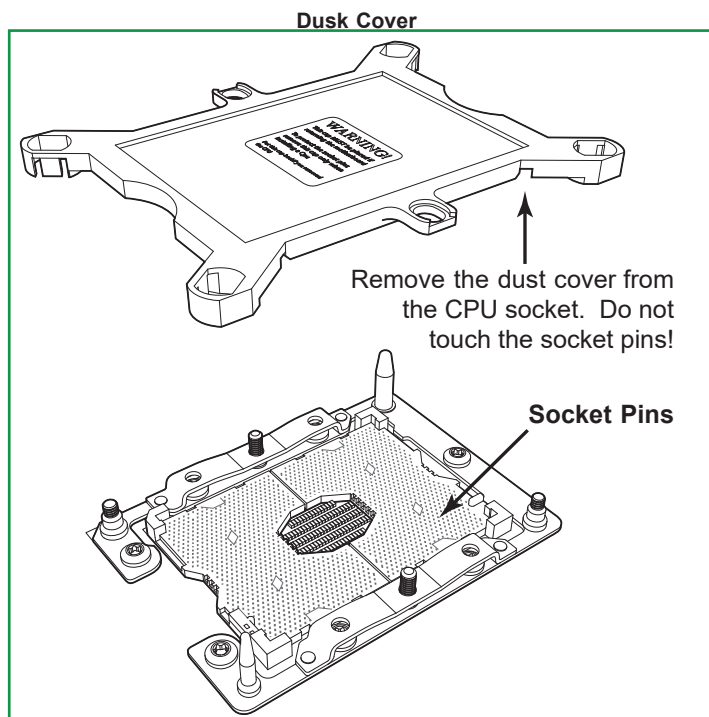

Installing the Processor Heatsink Module (PHM)

1. Once you have assembled the processor heatsink module (PHM) by following the instructions listed on page 29 or page 30, you are ready to install the processor heatsink module (PHM) into the CPU socket on the motherboard. To install the PHM into the CPU socket, follow the instructions below.
2. Locate the triangle (pin 1) on the CPU socket, and locate the triangle (pin 1) at the corner of the PHM that is closest to "1." (If you have difficulty locating pin 1 of the PHM, turn the PHM upside down. With the LGA-lands side facing up, you will note the hollow triangle located next to a screw at the corner. Turn the PHM right side up, and you will see a triangle marked on the processor clip at the same corner of hollow triangle.)
3. Carefully align pin 1 (the triangle) on the PHM against pin 1 (the triangle) on the CPU socket.
4. Once they are properly aligned, insert the two diagonal oval holes on the heatsink into the guiding posts.
5. Using a T30 Torx-bit screwdriver, install four screws into the mounting holes on the socket to securely attach the PHM onto the motherboard starting with the screw marked "1" (in the sequence of 1, 2, 3, and 4).

Note: Do not use excessive force when tightening the screws to avoid damaging the LGA-lands and the processor.

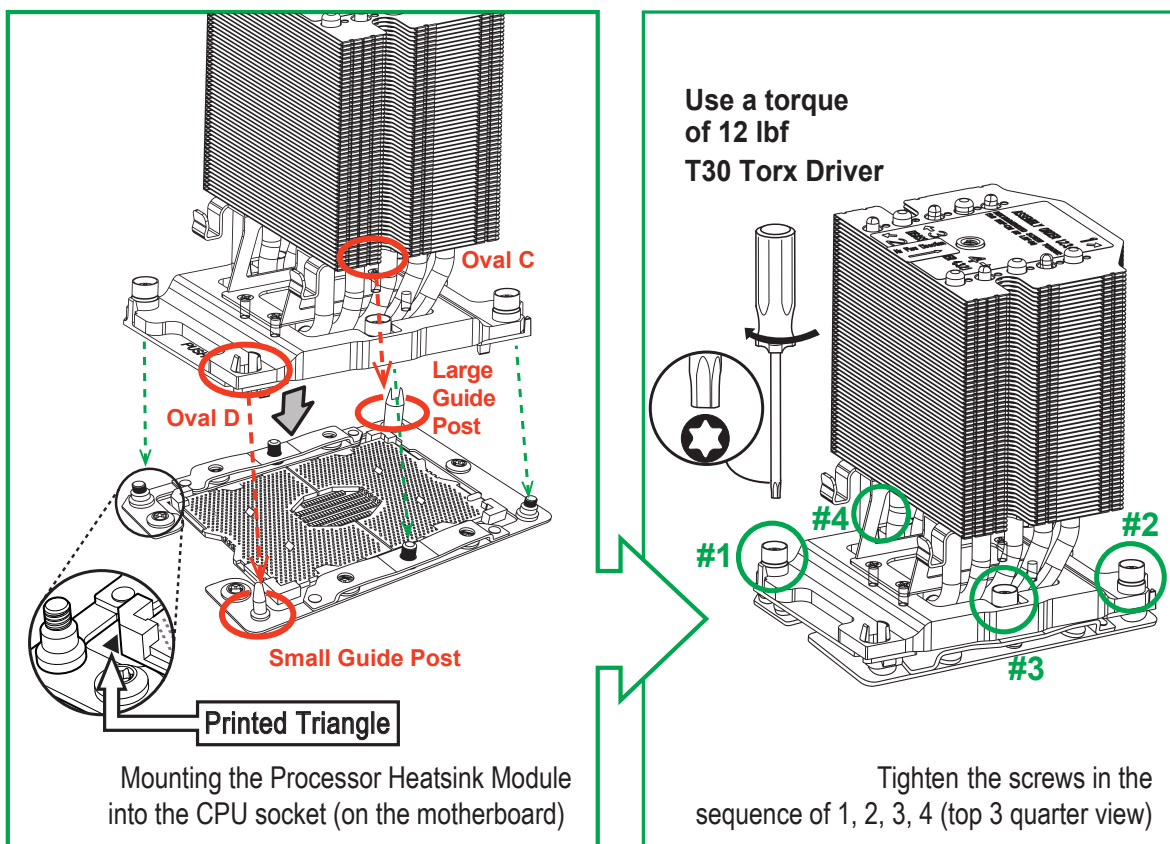

Removing the Processor Heatsink Module (PHM) from the Motherboard

Before removing the processor heatsink module (PHM), unplug power cord from the power outlet.

1. Using a T30 Torx-bit screwdriver, turn the screws on the PHM counterclockwise to loosen them from the socket, starting with screw marked #4 (in the sequence of 4, 3, 2, 1).
2. After all four screws are removed, wiggle the PHM gently and pull it up to remove it from the socket.

Note: To properly remove the processor heatsink module, be sure to loosen and remove the screws on the PHM in the sequence of 4, 3, 2, 1 as shown below.

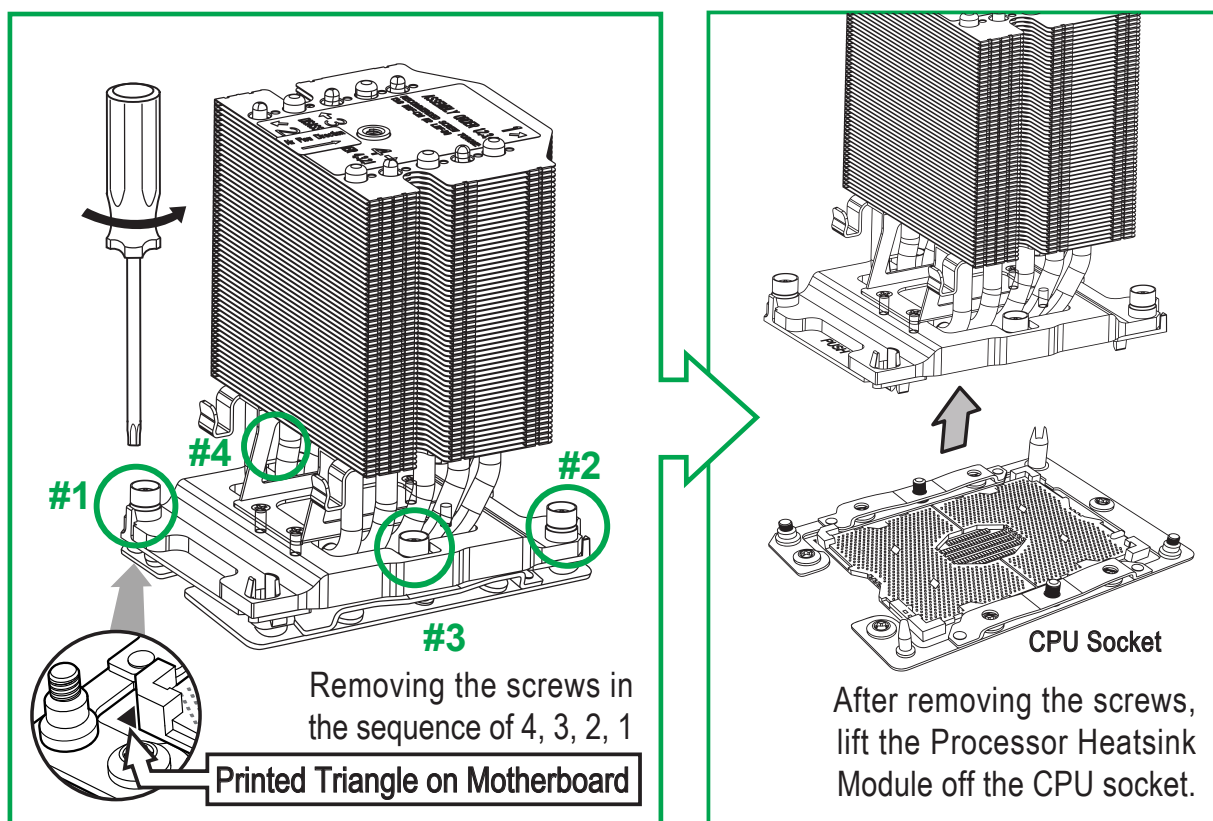

Air Shroud

The air shroud is used to concentrate airflow to maximize fan efficiency. The air shroud does not require screws to set up.

Installing the Air Shroud

1. Lay the chassis on a flat, stable surface and remove the chassis cover.
2. If necessary, move any cables that interfere with the air shroud placement.
3. Place the air shroud in the chassis. The air shroud fits just behind the three fans in the fan rack. Slide the air shroud into the grooves just behind the fan rack.
4. Reroute any cables that were moved and replace the chassis cover.

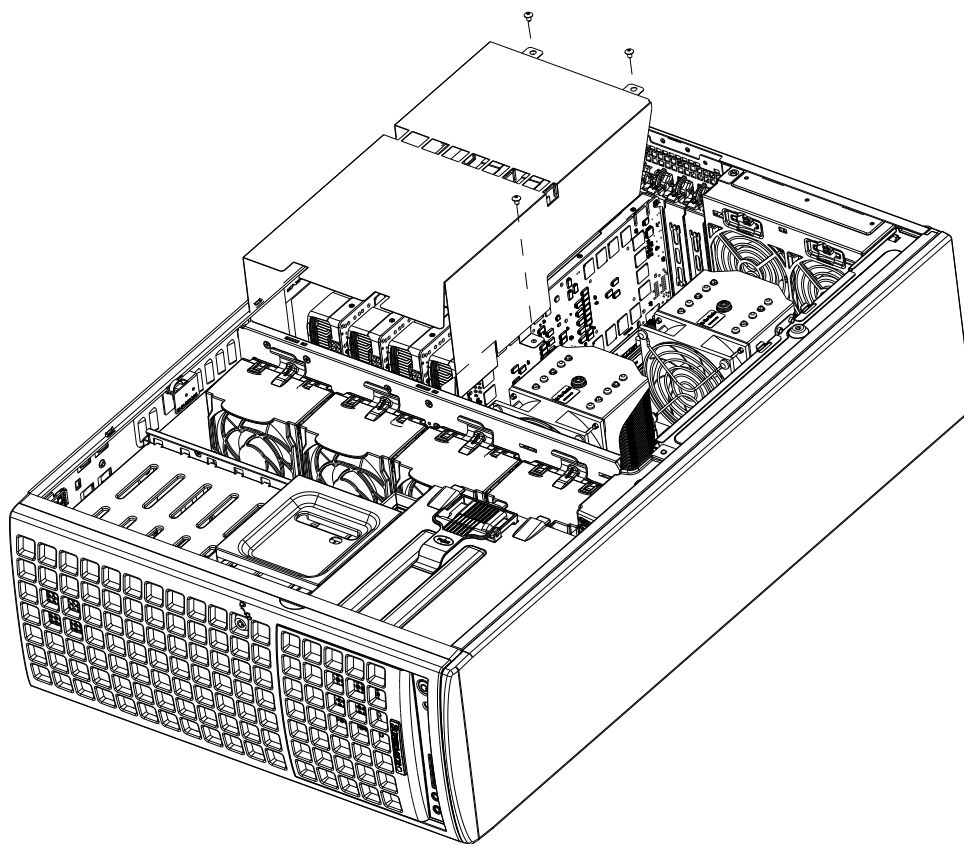

Figure 3-1. Installing the Air Shroud

System Cooling

Heavy-duty fans provide cooling for the chassis. Four fans are located in the mid-section of the chassis, two fans are located in the rear, and two optional fans can be mounted on the external rear of the chassis, required for passive GPUs.

The internal fans come pre-installed to the chassis. Each fan is hot-swappable and can be replaced without removing any connections.

System Fan Failure

Fan speed is controlled by system temperature through IPMI. If a fan fails, the remaining fans will ramp up to full speed. Replace any failed fan at your earliest convenience with the same type and model (the system can continue to run with a failed fan).

Replacing System Fans

The chassis contains two types of system fans: mid-system fans and rear system fans.

Replacing Mid-System Fans (FAN-0114L4 and FAN-0138L4)

1. Determine which fan has failed. Because the fans are hot-swappable, the system does not need to be powered-down.
2. Press the fan release tab and lift the failed fan from the chassis. Mid fans must be pulled straight out of the chassis. Part numbers: top two fans are FAN-0114L4 and bottom two are FAN-0138L4.
3. Place the new fan into the vacant space in the housing while making sure the arrows on the top of the fan (indicating air direction) point in the same direction as the arrows on the other fans. As soon as the fan is connected, it will begin working.

Replacing the Rear System Fan (FAN-0082L4)

1. Determine which fan has failed.
2. Press the rear fan release tab.
3. Pull the fan away from the chassis by pulling out the top first.
4. Place the new fan in the chassis, inserting the bottom of the fan first.
5. Push the fan fully into the housing until the fan clicks into place. Power up the system and check that the fan is working properly before replacing the chassis cover.

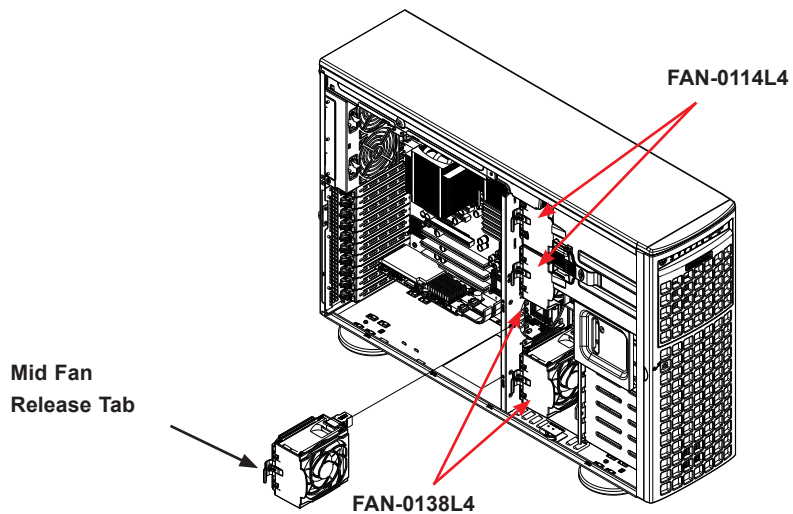

Figure 3-2. Mid-System Chassis Fans

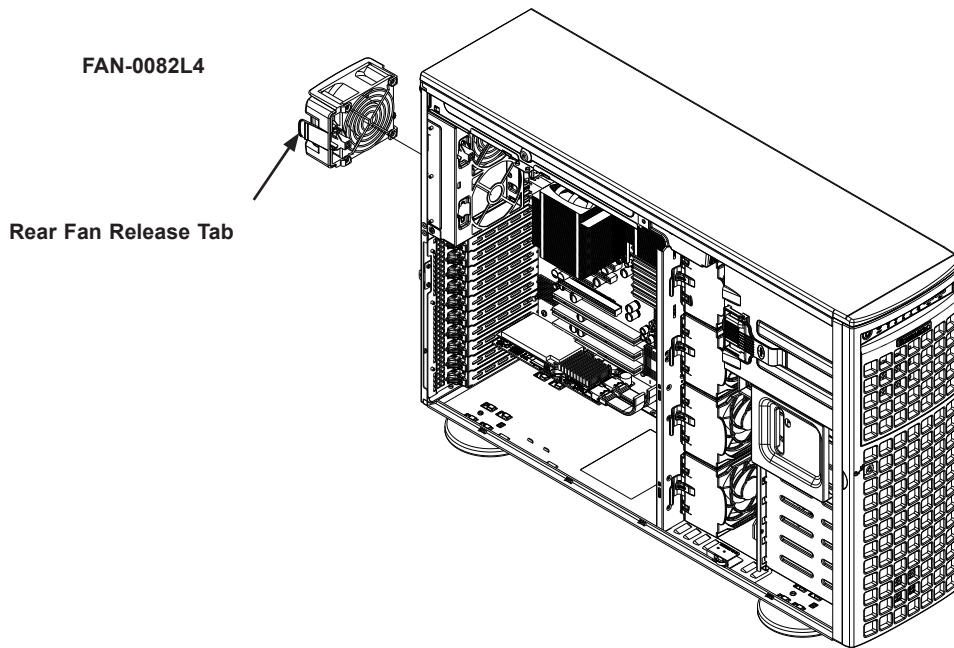

Figure 3-3. Rear System Chassis Fans

Drive Carrier Indicators

Each drive carrier has two LED indicators: an activity indicator and a status indicator. For RAID configurations using a controller, the meaning of the status indicator is described in the table below. For OS RAID or non-RAID configurations, some LED indications are not supported, such as hot spare. For VROC configurations, refer to the VROC appendix in this manual.

Drive Carrier LED Indicators			
	Color	Blinking Pattern	Behavior for Device
Activity LED	Blue	Solid On	SAS/NVMe drive installed
	Blue	Blinking	I/O activity
Status LED	Red	Solid On	Failure of drive with RSTe support
	Red	Blinking at 1 Hz	Rebuilding drive with RSTe support
	Red	Blinking with two blinks and one stop at 1 Hz	Hot spare for drive with RSTe support <i>(not supported in VMD mode)</i>
	Red	On for five seconds, then off	Power on for drive with RSTe support
	Red	Blinking at 4 Hz	Identify drive with RSTe support
	Green	Solid On	Safe to remove NVMe device <i>(not supported in VMD mode)</i>
	Amber	Blinking at 1 Hz	Attention state—do not remove NVMe device <i>(not supported in VMD mode)</i>

Note: Enterprise level hard disk drives are recommended for use in Supermicro chassis and servers. For information on recommended HDDs, visit the Supermicro website at <https://www.supermicro.com/products/nfo/Ultra.cfm>.

3.4 Memory Support and Installation

The X11DPG-QT supports up to 4TB of 3DS Load Reduced DIMM (3DS LRDIMM), 3DS Registered DIMM (3DS RDIMM), or up to 2TB of Load Registered DIMM (LRDIMM), with speeds of 2933*/2666/2400/2133/1866/1600/1333 MHz modules in 16 memory slots (*Notes below). Populating the DDR4 memory module in 2DPC system configuration on this MBD will affect memory bandwidth performance. Populating these DIMM modules with a pair of memory modules of the same type and size will result in interleaved memory, which will improve memory performance.

Notes:

- Be sure to use the memory modules of the same type and speed on the motherboard. Mixing of memory modules of different types and speeds is not allowed.
- When installing memory modules, be sure to populate the first DIMM module on the blue memory slot, which is the first memory slot of a memory channel, and then populate the second DIMM in the black slot if 2DPC memory configuration is used.
- Memory speed is dependent on the type of processors used in your system.
- Populating DDR4 memory modules in a two-DIMMs per-channel (2DPC) configuration on this motherboard will affect memory bandwidth and performance.
- Unbalanced memory configuration is not recommended.
- 2933 MHz memory is supported by 2nd Generation Intel Xeon Scalable-SP (82xx/62xx series) processors only.
- The memory capacity support will differ according to the processor SKUs.

DDR4 Memory Support for Intel Xeon Scalable-SP Processors

DDR4 Memory Support							
Type	Ranks Per DIMM and Data Width	DIMM Capacity (GB)			Speed (MT/s)		
					One Slot per Channel	Two Slots per Channel	
		DRAM Density			One DIMM per Channel	One DIMM per Channel	Two DIMMs per Channel
		4Gb	8Gb		1.2 Volts	1.2 Volts	1.2 Volts
RDIMM	SRx4	4GB	8GB	2666	2666	2666	
	SRx8	8GB	16GB				
	DRx8	8GB	16GB				
	DRx4	16GB	32GB				
RDIMM 3Ds	QRX4	N/A	2H-64GB				
	8RX4	N/A	4H-128GB				
LRDIMM	QRx4	32GB	64GB				
LRDIMM 3Ds	QRx4	N/A	2H-64GB				
	8Rx4	N/A	4H-128 GB				

DDR4 Memory Support for 2nd Gen Intel Xeon Scalable-SP Processors

DDR4 Memory Support							
Type	Ranks Per DIMM and Data Width	DIMM Capacity (GB)			Speed (MT/s)		
					One Slot per Channel	Two Slots per Channel	
		DRAM Density			One DIMM per Channel	One DIMM per Channel	Two DIMMs per Channel
		4 Gb*	8 Gb	16 Gb	1.2 Volts	1.2 Volts	1.2 Volts
RDIMM	SRx4	4 GB	8 GB	16 GB	2933**	2933**	2933**
	SRx8	8 GB	16 GB	32 GB			
	DRx8	8 GB	16 GB	32 GB			
	DRx4	16 GB	32 GB	64 GB			
RDIMM 3Ds	QRX4	N/A	2H-64GB	2H-128GB			
	8RX4	N/A	4H-128GB	4H-256GB			
LRDIMM	QRx4	32 GB	64 GB	128 GB			
LRDIMM 3Ds	QRx4	N/A	2H-64GB	2H-64GB			
	8Rx4	N/A	4H-128 GB	4H-256 GB			

Notes:

- 2933 MHz memory support in two-DIMMs per-channel (2DPC) configuration can be achieved by using memory purchased from Supermicro.
- 2933 MHz memory is supported by 2nd Generation Intel Xeon Scalable-SP processors only.

DIMM Population Guidelines for Optimal Performance

For optimal memory performance, follow the instructions listed in the tables below when populating memory modules.

Key Parameters for DIMM Configuration

Key Parameters for DIMM Configurations	
Parameters	Possible Values
Number of Channels	1, 2, 3, 4, 5, or 6
Number of DIMMs per Channel	1DPC (1 DIMM Per Channel) or 2DPC (2 DIMMs Per Channel)
DIMM Type	RDIMM (w/ECC), 3DS RDIMM, LRDIMM, 3DS LRDIMM
DIMM Construction	non-3DS RDIMM Raw Cards: A/B (2Rx4), C (1Rx4), D (1Rx8), E (2Rx8) 3DS RDIMM Raw Cards: A/B (4Rx4) non-3DS LRDIMM Raw Cards: D/E (4Rx4) 3DS LRDIMM Raw Cards: A/B (8Rx4)

General DIMM Mixing Guidelines

- All DIMMs must be all DDR4 DIMMs.
- x4 and x8 DIMMs can be mixed in the same channel.
- Mixing of LRDIMMs and RDIMMs is not allowed in the same channel, across different channels, and across different sockets.
- Mixing of non-3DS and 3DS LRDIMM is not allowed in the same channel, across different channels, and across different sockets.

Mixing of DIMM Types within a Channel

DIMM Types	RDIMM	LRDIMM	3DS LRDIMM
RDIMM	Allowed	Not Allowed	Not Allowed
LRDIMM	Not Allowed	Allowed	Not Allowed
3DS LRDIMM	Not Allowed	Not Allowed	Allowed

DIMM Population Table

Note: Unbalanced memory configuration decreases memory performance and is not recommended for Supermicro motherboards.

Memory Population Table for the Motherboard Using Intel Xeon Scalable-SP and 2nd Gen Intel Xeon Scalable-SP Processors

Memory Population Table for the X11DP Motherboard w/16 DIMM Slots Onboard	
When 1 CPU is used:	Memory Population Sequence
1 CPU & 1 DIMM	CPU1: P1-DIMMA1
1 CPU & 2 DIMMs	CPU1: P1-DIMMA1/P1-DIMMD1
1 CPU & 3 DIMMs	CPU1: P1-DIMMC1/P1-DIMMB1/P1-DIMMA1
1 CPU & 4 DIMMs	CPU1: P1-DIMMB1/P1-DIMMA1/P1-DIMMD1/P1-DIMME1
1 CPU & 5 DIMMs (Unbalanced: not recommended)	CPU1: P1-DIMMC1/P1-DIMMB1/P1-DIMMA1/P1-DIMMD1/P1-DIMME1
1 CPU & 6 DIMM	CPU1: P1-DIMMC1/P1-DIMMB1/P1-DIMMA1/P1-DIMMD1/P1-DIMME1/P1-DIMMF1
1 CPU & 7 DIMMs (Unbalanced: not recommended)	CPU1: P1-DIMMC1/P1-DIMMB1/P1-DIMMA1/P1-DIMMA2/P1-DIMMD1/P1-DIMME1/P1-DIMMF1
1 CPU & 8 DIMMs (Unbalanced: not recommended)	(CPU1: P1-DIMMC1/P1-DIMMB1/P1-DIMMA1/P1-DIMMA2/P1-DIMMD2/P1-DIMMD1/P1-DIMME1/P1-DIMMF1
When 2 CPUs are used:	Memory Population Sequence
2 CPUs & 2 DIMMs	CPU1: P1-DIMMA1 CPU2: P2-DIMMA1
2 CPUs & 4 DIMMs	CPU1: P1-DIMMA1/P1-DIMMD1 CPU2: P2-DIMMA1/P2-DIMMD1
2 CPUs & 6 DIMMs	CPU1: P1-DIMMC1/P1-DIMMB1/P1-DIMMA1 CPU2: P2-DIMMC1/P2-DIMMB1/P2-DIMMA1
2 CPUs & 8 DIMMs	CPU1: P1-DIMMB1/P1-DIMMA1/P1-DIMMD1/P1-DIMME1 CPU2: P2-DIMMB1/P2-DIMMA1/P2-DIMMD1/P2-DIMME1
2 CPUs & 10 DIMMs	CPU1: P1-DIMMC1/P1-DIMMB1/P1-DIMMA1/P1-DIMMD1/P1-DIMME1/P1-DIMMF1 CPU2: P2-DIMMB1/P2-DIMMA1/P2-DIMMD1/P2-DIMME1
2 CPUs & 12 DIMM	CPU1: P1-DIMMC1/P1-DIMMB1/P1-DIMMA1/P1-DIMMD1/P1-DIMME1/P1-DIMMF1 CPU2: P2-DIMMC1/P2-DIMMB1/P2-DIMMA1/P2-DIMMD1/P2-DIMME1/P2-DIMMF1
2 CPUs & 14 DIMMs (Unbalanced: not recommended)	CPU1: P1-DIMMC1/P1-DIMMB1/P1-DIMMA1/P1-DIMMA2/P1-DIMMD1/P1-DIMME1/P1-DIMMF1 CPU2: P2-DIMMC1/P2-DIMMB1/P2-DIMMA1/P2-DIMMA2/P2-DIMMD1/P2-DIMME1/P2-DIMMF1
2 CPUs & 16 DIMMs (Unbalanced: not recommended)	CPU1: P1-DIMMC1/P1-DIMMB1/P1-DIMMA1/P1-DIMMA2/P1-DIMMD2/P1-DIMMD1/P1-DIMME1/P1-DIMMF1 CPU2: P2-DIMMC1/P2-DIMMB1/P2-DIMMA1/P2-DIMMA2/P2-DIMMD2/P2-DIMMD1/P2-DIMME1/P2-DIMMF1

Installing Memory

1. Remove power from the system as described in Section 3.1.
2. Starting with the slot in the order described previously, push the release tab outward to unlock it.

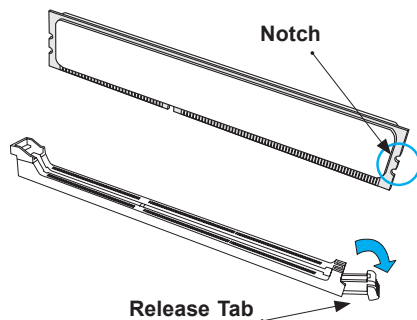

3. Align the key of the DIMM with the receptive point on the memory slot and with your thumbs on both ends of the module, press it straight down into the slot until the module snaps into place.

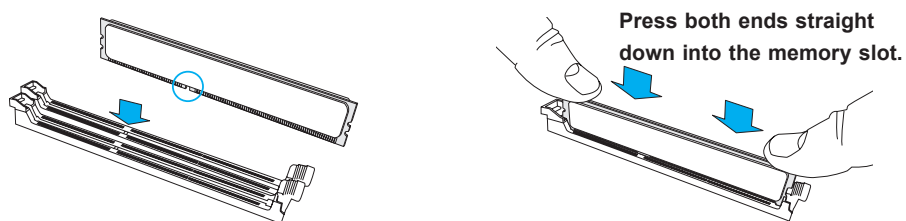

4. Press the release tab to the locked position to secure the DIMM module into the slot.

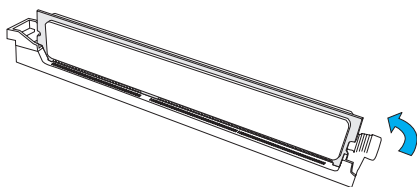

5. Repeat the procedure for the remaining DIMM modules in the order detailed in the previous section.

To remove a DIMM module, unlock the release tabs then pull the module from the slot.

Motherboard Battery

The motherboard uses non-volatile memory to retain system information when system power is removed. This memory is powered by a lithium battery residing on the motherboard.

Replacing the Battery

1. Remove power from the system as described in section 3.1 and remove the node from the chassis.
2. Push aside the small clamp that covers the edge of the battery. When the battery is released, lift it out of the holder.
3. To insert a new battery, slide one edge under the lip of the holder with the positive (+) side facing up. Then push the other side down until the clamp snaps over it.

Note: Handle used batteries carefully. Do not damage the battery in any way; a damaged battery may release hazardous materials into the environment. Do not discard a used battery in the garbage or a public landfill. Please comply with the regulations set up by your local hazardous waste management agency to dispose of your used battery properly.

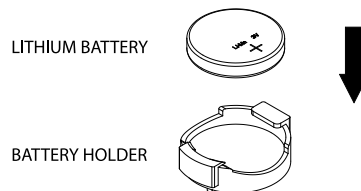

Figure 3-4. Installing the Onboard Battery

Warning: There is a danger of explosion if the onboard battery is installed upside down (which reverses its polarities). This battery must be replaced only with the same or an equivalent type recommended by the manufacturer (CR2032).

Chapter 4

Motherboard Connections

This section describes the connections on the motherboard and provides pinout definitions. Note that depending on how the system is configured, not all connections are required. The LEDs on the motherboard are also described here. A serverboard layout indicating component locations may be found in Chapter 1.

Please review the Safety Precautions in Appendix B before installing or removing components.

4.1 Power Connections

Two power connections on the 7049GP-TRT must be connected to the power supply. The wiring is included with the power supply.

- 24-pin Primary ATX Power (JPWR1)
- 8-pin Processor Power (JPWR2)

Main ATX Power Supply Connector

The primary power supply connector (JPWR1) meets the ATX SSI EPS 24-pin specification.

Warning: To provide adequate power to your system and to avoid damaging the power supply or the motherboard, be sure to connect all power connectors mentioned above to the power supply. Failure in doing so may void the manufacturer warranty on your power supply and motherboard.

ATX Power 24-pin Connector Pin Definitions			
Pin#	Definition	Pin#	Definition
13	+3.3V	1	+3.3V
14	NC	2	+3.3V
15	Ground	3	Ground
16	PS_ON	4	+5V
17	Ground	5	Ground
18	Ground	6	+5V
19	Ground	7	Ground
20	Res (NC)	8	PWR_OK
21	+5V	9	5VSB
22	+5V	10	+12V
23	+5V	11	+12V
24	Ground	12	+3.3V

12V 8-pin PWR Connector Pin Definitions	
Pins	Definition
1 through 4	Ground
5 through 8	+12V

4.2 Headers and Connectors

Fan Headers

There are eight fan headers on the motherboard. These are 4-pin fan headers; pins 1-3 are backward compatible with traditional 3-pin fans. The onboard fan speeds are controlled by Thermal Management (via Hardware Monitoring) in the BIOS. When using Thermal Management setting, please use all 3-pin fans or all 4-pin fans.

Fan Header Pin Definitions	
Pin#	Definition
1	Ground (Black)
2	+12V (Red)
3	Tachometer
4	PWM Control

Internal Speaker/Buzzer

The Internal Speaker/Buzzer (SP1) is used to provide audible indications for various beep codes. See the table below for pin definitions.

Internal Buzzer Pin Definitions		
Pin#	Definition	
1	Pos (+)	Beep In
2	Neg (-)	Alarm Speaker

S-SGPIO Header

A Serial General Purpose Input/Output header (S-SGPIO) is located on the motherboard. This header is used to communicate with the enclosure management chip on the backplane. See the table below for pin definitions.

SGPIO Header Pin Definitions			
Pin#	Definition	Pin#	Definition
1	NC	2	NC
3	Ground	4	DATA Out
5	Load	6	Ground
7	Clock	8	NC

NC = No Connection

Disk-On-Module Power Connector

The Disk-On-Module (DOM) power connectors at JSD1 and JSD2 provide 5V power to a solid-state DOM storage devices connected to one of the SATA ports. See the table below for pin definitions.

DOM Power Pin Definitions	
Pin#	Definition
1	5V
2	Ground
3	Ground

TPM Header

The JTPM1 header is used to connect a Trusted Platform Module (TPM)/Port 80, which is available from a third-party vendor. A TPM/Port 80 connector is a security device that supports encryption and authentication in hard drives. It allows the motherboard to deny access if the TPM associated with the hard drive is not installed in the system. See the table below for pin definitions.

Trusted Platform Module/Port 80 Header Pin Definitions			
Pin#	Definition	Pin#	Definition
1	P3V3	2	SPI_TPM_CS_N
3	PCIE_RESET_N#	4	SPI_PCH_MISO
5	SPI_PCH_CLK#	6	Ground
7	SPI_PCH_MOSI	8	N/A
9	JTPM1_P3V3A	10	IRQ_TPM_SPIN_N

Chassis Intrusion

A Chassis Intrusion header is located at JL1 on the motherboard. Attach the appropriate cable from the chassis to the header to inform you when the chassis is opened.

Chassis Intrusion Pin Definitions	
Pins	Definition
1	Intrusion Input
2	Ground

4-pin BMC External I²C Header

A System Management Bus header for IPMI 2.0 is located at JIPMB1. Connect a cable to this header to use the IPMB I²C connection on your system. See the table below for pin definitions.

External I ² C Header Pin Definitions	
Pin#	Definition
1	Data
2	Ground
3	Clock
4	No Connection

Power SMB (I²C) Header

Power System Management Bus (I²C) header at JPI²C1 monitors the power supply, fan and system temperatures. Refer to the table below for pin definitions.

Power SMB Header Pin Definitions	
Pin#	Definition
1	Clock
2	Data
3	Power Fail
4	Ground
5	+3.3V

I-SATA 3.0 and S-SATA 3.0 Ports

The X11DPG-QT has eight I-SATA 3.0 ports (I-SATA0~3, I-SATA4~7) which are supported by the Intel® C621 chipset. In addition, it also has two S-SATA 3.0 ports (S-SATA4/ S-SATA5) that are supported by the Intel® SCU. S-SATA4/5 can be used with Supermicro SuperDOMs which are yellow SATA DOM connectors with power pins built in, and do not require external power cables. Supermicro SuperDOMs are backward-compatible with regular SATA HDDs or SATA DOMs that need external power cables. All these SATA ports provide serial-link signal connections, which are faster than the connections of Parallel ATA.

SATA 3.0 Port Pin Definitions	
Pin#	Signal
1	Ground
2	SATA_TXP
3	SATA_TXN
4	Ground
5	SATA_RXN
6	SATA_RXP
7	Ground

RAID Key Header

A RAID_Key header is located at JRK1 on the motherboard. RAID key is used to support onboard NVMe connections.

RAID Key Header Pin Definitions	
Pin#	Definition
1	Ground
2	RAID_KEY_PU
3	Ground
4	PCH_RAID_KEY

Audio Front Panel Header

A 10-pin audio header (AUDIO_FP) located on the motherboard allows you to use the onboard sound chip (ALC888S) for audio functions. Connect an audio cable to the this header to use this feature. See the table below for pin definitions.

Audio Header Pin Definitions			
Pin#	Definition	Pin#	Definition
1	Microphone_Left	2	Audio_Ground
3	Microphone_Right	4	Audio_Detect
5	Line_2_Right	6	Ground
7	Jack_Detect	8	Key
9	Line_2_Left	10	Ground

SPDIF_IN Header

The Sony/Philips Digital Interface (JSPDIF_IN1) header is used for digital audio. Place a cap on each header for audio support. You will also need to have a cable to use the connection.

SPDIF_In Pin Definitions	
Pin#	Definition
1	S/PDIF_In
2	Ground

Micro SD Card Slot

Insert a Micro SD memory card into the expansion slot at JSDCARD1 for additional memory or OS image.

NVMe I²C Header

JNVI²C1 and JNVI²C2 are management headers for the Supermicro AOC NVMe PCIe peripheral cards. Please connect the I²C cable to the connector. Also, JNVI²C1 and JNVI²C2 are VPP headers for NVMe add-on cards on PCIe slots 9 and 10 respectively.

Standby Power

The standby power header is located at JSTBY1 on the motherboard. Refer to the table below for pin definitions.

Standby Power Pin Definitions	
Pin#	Definition
1	+5V Standby
2	Ground
3	No Connection

I/O Header for Thunderbolt

The JTBT1 header is a general purpose I/O header for a Thunderbolt add-on card.

PCIe M.2 Connector (M.2 Connector)

The PCIe M.2 connector is for devices such as memory cards, wireless adapters, etc. These devices must conform to the PCIe M.2 specifications (formerly known as NGFF). Also, the M.2 socket on the motherboard supports PCIe 3.0 x4 (32 Gb/s) SSD cards in the 2280 and 22110 form factors.

NC-SI Header for IPMI Support

A Network-Controller Sideband Interface (NC-SI) header is located at JNCSI1 on the motherboard. Connect an appropriate cable from this header to an add-on card to provide the out-of-band (sideband) connection between the onboard Baseboard Management Controller (BMC) and a Network Interface Controller (NIC) for remote management. For the network sideband interface to work properly, you will need to use a motherboard that supports NC-SI and also need to have a special cable. Please contact Supermicro at www.supermicro.com to purchase the cable for this header. Refer to the table below for pin definitions.

NC-SI Header for IPMI Support Pin Definitions			
Pin#	Definition	Pin#	Definition
1	CLK_50MHz	2	Ground
3	NCSI_CRSDV	4	Ground
5	NCSI_RXD0	6	Ground
7	NCSI_RXD1	8	Ground
9	NCSI_TXD0	10	Ground
11	NCSI_TXD1	12	Ground
13	NCSI_TX_EX	14	NCSI_PRESENT_N
15	NC	16	NC
17	5V STBY	18	5V STBY
19	5V STBY	20	5V STBY
21	5V STBY	22	NC

Inlet Sensor Header

This header (JSEN1) allows BMC to monitor thermal inlet temperature. A special module is required. Please contact Supermicro at www.supermicro.com to purchase the module for this header. Refer to the table below for pin definitions.

Inlet Sensor Header Pin Definitions	
Pin#	Definition
1	SMBDAT
2	Ground
3	SMBCLK
4	3.3V STBY

HFI Debug Port for Fabric CPU (JTAG_HFI1)

This connector (JTAG_HFI1) is the JTAG port and provides miscellaneous signals connectivity requirements of the Fabric CPU debug port. Refer to the table below for pin definitions.

HFI Debug Port for Fabric CPU Pin Definitions			
Pin#	Definition	Pin#	Definition
1	CD_TCK	2	Ground
3	CD_TDO	4	VCCH
5	CD_TMS	6	CD_TRST_N
7	CPU_PWRGD	8	NC
9	CD_TDI	10	Ground

4.3 Ports

Rear I/O Ports

See the figure below for the locations and descriptions of the various I/O ports on the rear of the motherboard.

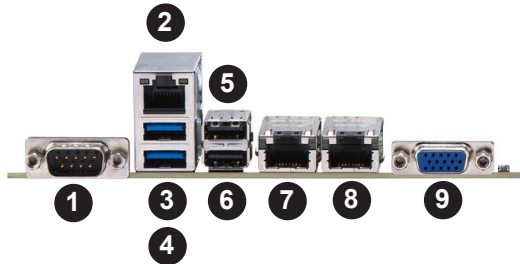

Figure 4-2. Rear I/O Ports

Rear I/O Ports			
#	Description	#	Description
1.	COM Port 1	6.	USB Port 1
2.	Dedicated IPMI LAN Port	7.	LAN Port 1
3.	USB 3.0 Port 4	8.	LAN Port 2
4.	USB 3.0 Port 5	9.	VGA Port
5.	USB Port 0		

VGA Port

One VGA port is located next to LAN Port 2 on the I/O back panel. Use this connection for VGA display.

Serial Port

There is one COM port (COM1) on the I/O back panel and one COM header (COM2) on the motherboard. This COM ports provide serial communication support. See the table below for pin definitions.

COM Port Pin Definitions			
Pin#	Definition	Pin#	Definition
1	DCD	6	DSR
2	RXD	7	RTS
3	TXD	8	CTS
4	DTR	9	RI
5	Ground	10	N/A

LAN Ports

Two LAN ports (LAN1, LAN2) are located on the I/O back panel. These ports accept RJ45 type cables.

LAN Port Pin Definition			
Pin#	Definition	Pin#	Definition
1	TX_D1+	5	BI_D3-
2	TX_D1-	6	RX_D2-
3	RX_D2+	7	BI_D4+
4	BI_D3+	8	BI_D4-

Universal Serial Bus (USB) Ports

There are two USB 3.0 ports (USB 4/5) located on the I/O back panel. The motherboard also has a front access USB 3.0 header that supports two USB connections (USB 6/7). A USB Type A header, USB 8, also provides USB 3.0 support. The onboard headers can be used to provide front side USB access with a cable (not included).

Back Panel USB (3.0) Pin Definitions			
Pin#	Definition	Pin#	Definition
1	VBUS	10	Power
2	D-	11	USB 2.0 Differential Pair
3	D+	12	
4	Ground	13	Ground of PWR Return
5	StdA_SSRX-	14	SuperSpeed Receiver
6	StdA_SSRX+	15	Differential Pair
7	GND_DRAIN	16	Ground for Signal Return
8	StdA_SSTX-	17	SuperSpeed Transmitter
9	StdA_SSTX+	18	Differential Pair

Front Panel USB 3.0 Header Pin Definitions			
Pin#	Definition	Pin#	Definition
1	+5V	2	+5V
3	USB_PN2	4	USB_PN3
5	USB_PP2	6	USB_PP3
7	Ground	8	Ground
9	Key	10	Ground

Unit Identifier Switch/UID LED Indicator

A rear Unit Identifier (UID) switch (JUIDB1) and an rear LED Indicator (LED2) are located on the rear side of the system. The front UID LED is located on Pin 7 of the Front Control Panel (JF1). When you press the UID switch, both front and rear UID LED indicators will be turned on. Press the UID switch again to turn off the LEDs. The UID Indicators provide easy identification of a system unit that may be in need of service.

Note: UID can also be triggered via IPMI on the motherboard. For more information on IPMI, please refer to the IPMI User's Guide posted on our website at <http://www.supermicro.com>.

UID Switch Pin Definitions	
Pin#	Definition
1	Ground
2	Ground
3	Button In
4	Button In

UID LED Pin Definitions	
Color	Status
Blue: On	Unit Identified

IPMI LAN Port

A dedicated IPMI LAN port that supports Gigabit LAN is located next to USB 0/1 ports on the back panel. This LAN port is supported by the onboard AST 2500 BMC and accepts an RJ45 type cable. Refer to the LED Indicator Section for LAN LED information.

LAN Ports Pin Definitions			
Pin#	Definition	Pin#	Definition
1	P2V5SB	10	SGND
2	TD0+	11	Act LED
3	TD0-	12	P3V3SB
4	TD1+	13	Link 100 LED (Yellow, +3V3SB)
5	TD1-	14	Link 1000 LED (Yellow, +3V3SB)
6	TD2+	15	Ground
7	TD2-	16	Ground
8	TD3+	17	Ground
9	TD3-	18	Ground

4.4 Jumpers

Explanation of Jumpers

To modify the operation of the motherboard, jumpers are used to choose between optional settings. Jumpers create shorts between two pins to change the function associated with it. Pin 1 is identified with a square solder pad on the printed circuit board. See the motherboard layout page for jumper locations.

Note: On a two-pin jumper, "Closed" means the jumper is on both pins and "Open" indicates the jumper is either on only one pin or has been completely removed.

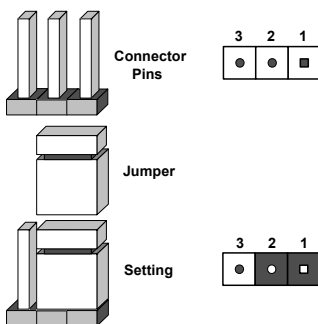

CMOS Clear

JBT1 is used to clear CMOS, which will also clear any passwords. Instead of pins, this jumper consists of contact pads to prevent accidentally clearing the contents of CMOS.

To Clear CMOS

1. First power down the system and unplug the power cord(s).
2. Remove the cover of the chassis to access the motherboard.
3. Remove the onboard battery from the motherboard.
4. Short the CMOS pads with a metal object such as a small screwdriver for at least four seconds.
5. Remove the screwdriver (or shorting device).
6. Replace the cover, reconnect the power cord(s) and power on the system.

Notes: Clearing CMOS will also clear all passwords.

Do not use the PW_ON connector to clear CMOS.



HD Audio Enable

JHD_AC1 allows you to enable or disable the onboard high definition audio support. See the table below for jumper settings

HD Audio Enable/Disable Jumper Settings	
Jumper Setting	Definition
Open	Enabled (Default)
Short	Disabled

Onboard Audio Enable

JPAC1 allows you to enable or disable the onboard audio support. The default position is on pins 1-2 to enable onboard audio connections. Refer to the table below for jumper settings.

Audio Enable/Disable Jumper Settings	
Jumper Setting	Definition
Pins 1-2	Enabled (Default)
Pins 2-3	Disabled

Watch Dog

JWD1 controls the Watch Dog function. Watch Dog is a monitor that can reboot the system when a software application hangs. Jumping pins 1-2 will cause Watch Dog to reset the system if an application hangs. Jumping pins 2-3 will generate a non-maskable interrupt signal for the application that hangs. Watch Dog must also be enabled in BIOS. The default setting is Reset.

Note: When Watch Dog is enabled, the user needs to write their own application software to disable it.

Watch Dog Jumper Settings	
Jumper Setting	Definition
Pins 1-2	Reset
Pins 2-3	NMI
Open	Disabled

Manufacturing Mode Select

Close JPME2 to bypass SPI flash security and force the system to use the Manufacturing Mode, which will allow you to flash the system firmware from a host server to modify system settings. See the table below for jumper settings.

Manufacturing Mode Select Jumper Settings	
Jumper Setting	Definition
Pins 1-2	Normal (Default)
Pins 2-3	Manufacturing Mode

VRM_I2C Jumper

Set this jumper (JVRM_SEL1) to Normal (Default) to allow BMC to access VRM controllers. Set this jumper to short pins 2-3 to have VRM code updated by PCH. See the table below for jumper settings.

VRM_I2C Jumper Settings	
Jumper Setting	Definition
Pins 1-2	Normal (Default)
Pins 2-3	VRM Program

10Gb LAN1/2 Enable/Disable

JPTG1 allows you to enable or disable the 10Gb LAN1/2. The default setting is Enabled.

10Gb LAN Enable/Disable Jumper Settings	
Jumper Setting	Definition
Pins 1-2	Enabled
Pins 2-3	Disabled

4.5 LED Indicators

Dedicated IPMI LAN LEDs

A dedicated IPMI LAN port is also included on the motherboard. The amber LED on the right of the IPMI LAN port indicates activity, while the green LED on the left indicates the speed of the connection. See the table below for more information.



IPMI LAN Link LEDs		
Color	Status	Definition
Off	Off	No Connection
Green: Solid	Link/Speed (Left)	100 Mb/s
Amber Blinking	Activity (Right)	Active

Unit ID LED

A rear UID LED indicator at LED2 is located near the UID switch on the I/O back panel. This UID indicator provides easy identification of a system unit that may need service.

UID LED LED Indicator	
LED Color	Definition
Blue: On	Unit Identified

Onboard Power LED

LEDPWR is an Onboard Power LED. When this LED is lit, it means that power is present on the motherboard. In suspend mode, this LED will blink on and off. Be sure to turn off the system and unplug the power cord(s) before removing or installing components.

Onboard Power LED Indicator	
LED Color	Definition
Off	System Off (power cable not connected)
Green	System On

BMC Heartbeat LED

LEDM1 is the BMC heartbeat LED. When the LED is blinking green, BMC is functioning normally. See the table below for the LED status.

Onboard Power LED Indicator	
LED Color	Definition
Green: Blinking	BMC Normal

Chapter 5

Software

After the hardware has been installed, you can install the Operating System (OS), configure RAID settings and install the drivers.

5.1 Microsoft Windows OS Installation

If you will be using RAID, you must configure RAID settings before installing the Windows OS and the RAID driver. Refer to the RAID Configuration User Guides posted on our website at www.supernmicro.com/support/manuals.

Installing the OS

1. Create a method to access the MS Windows installation ISO file. That might be a DVD, perhaps using an external USB/SATA DVD drive, or a USB flash drive, or the IPMI KVM console.
2. Retrieve the proper RST/RSTe driver. Go to the Supermicro web page for your motherboard and click on "Download the Latest Drivers and Utilities", select the proper driver, and copy it to a USB flash drive.
3. Boot from a bootable device with Windows OS installation. You can see a bootable device list by pressing **F11** during the system startup.

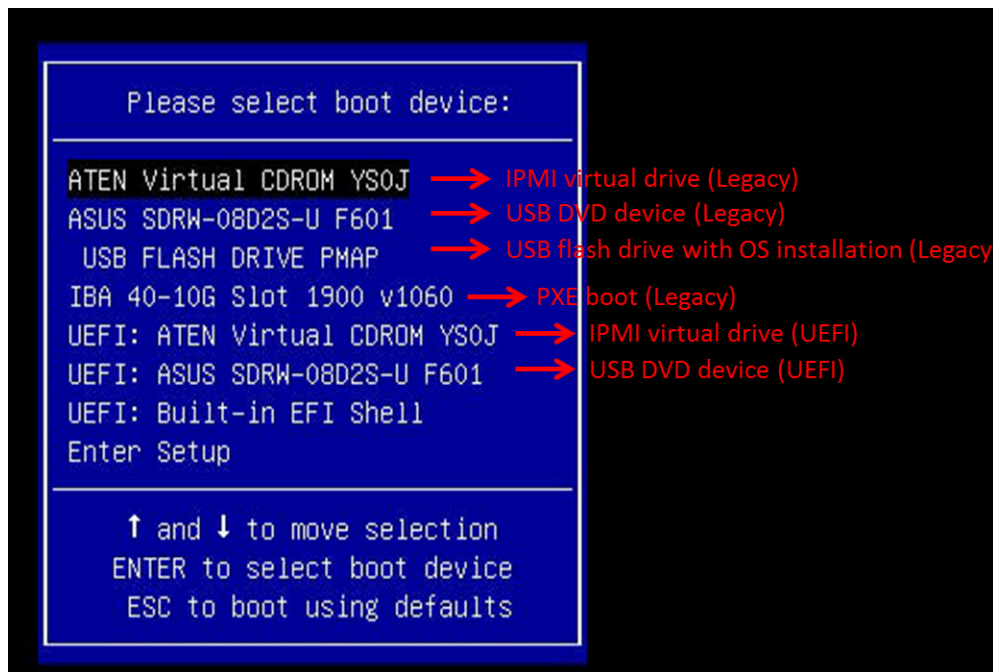

Figure 5-1. Select Boot Device

4. During Windows Setup, continue to the dialog where you select the drives on which to install Windows. If the disk you want to use is not listed, click on “Load driver” link at the bottom left corner.

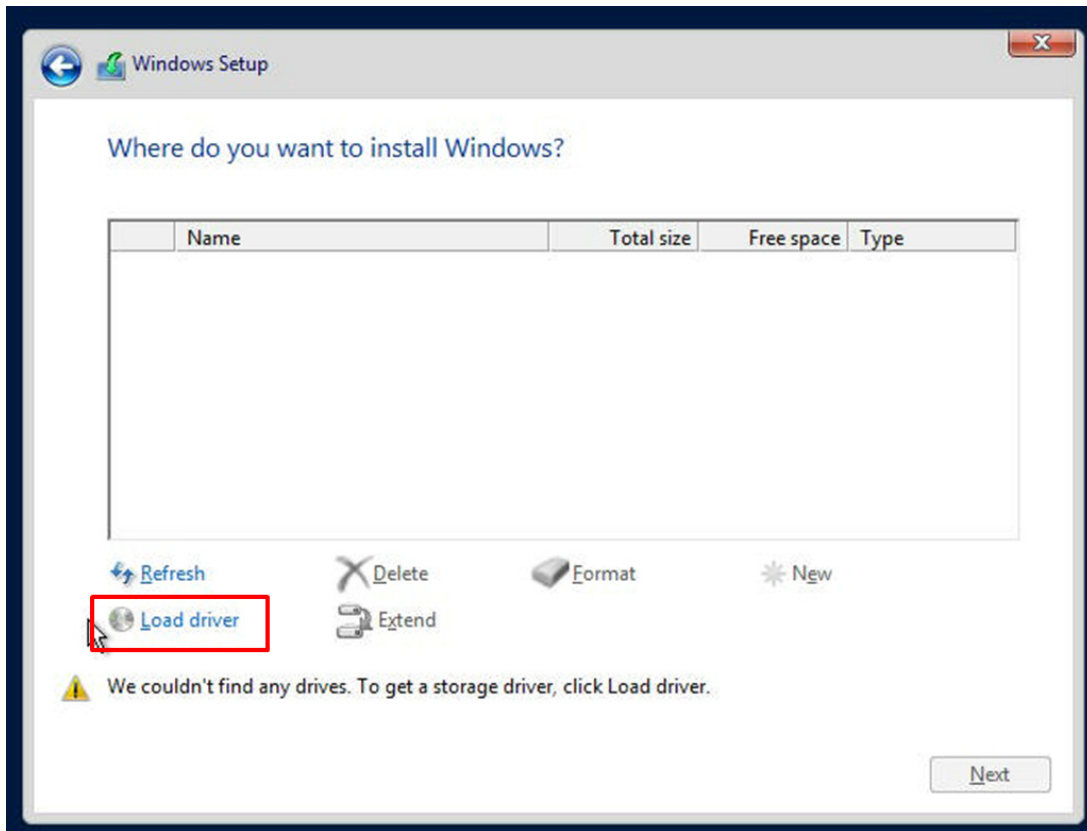

Figure 5-2. Load Driver Link

To load the driver, browse the USB flash drive for the proper driver files.

- For RAID, choose the SATA/sSATA RAID driver indicated then choose the storage drive on which you want to install it.
 - For non-RAID, choose the SATA/sSATA AHCI driver indicated then choose the storage drive on which you want to install it.
5. Once all devices are specified, continue with the installation.
 6. After the Windows OS installation has completed, the system will automatically reboot multiple times.

5.2 Driver Installation

The Supermicro website contains drivers and utilities for your system at <https://www.supermicro.com/wdl/driver>. Some of these must be installed, such as the chipset driver.

After accessing the website, go into the CDR_Images (in the parent directory of the above link) and locate the ISO file for your motherboard. Download this file to to a USB flash drive or a DVD. (You may also use a utility to extract the ISO file if preferred.)

Another option is to go to the Supermicro website at <http://www.supermicro.com/products/>. Find the product page for your motherboard, and "Download the Latest Drivers and Utilities".

Insert the flash drive or disk and the screenshot shown below should appear.

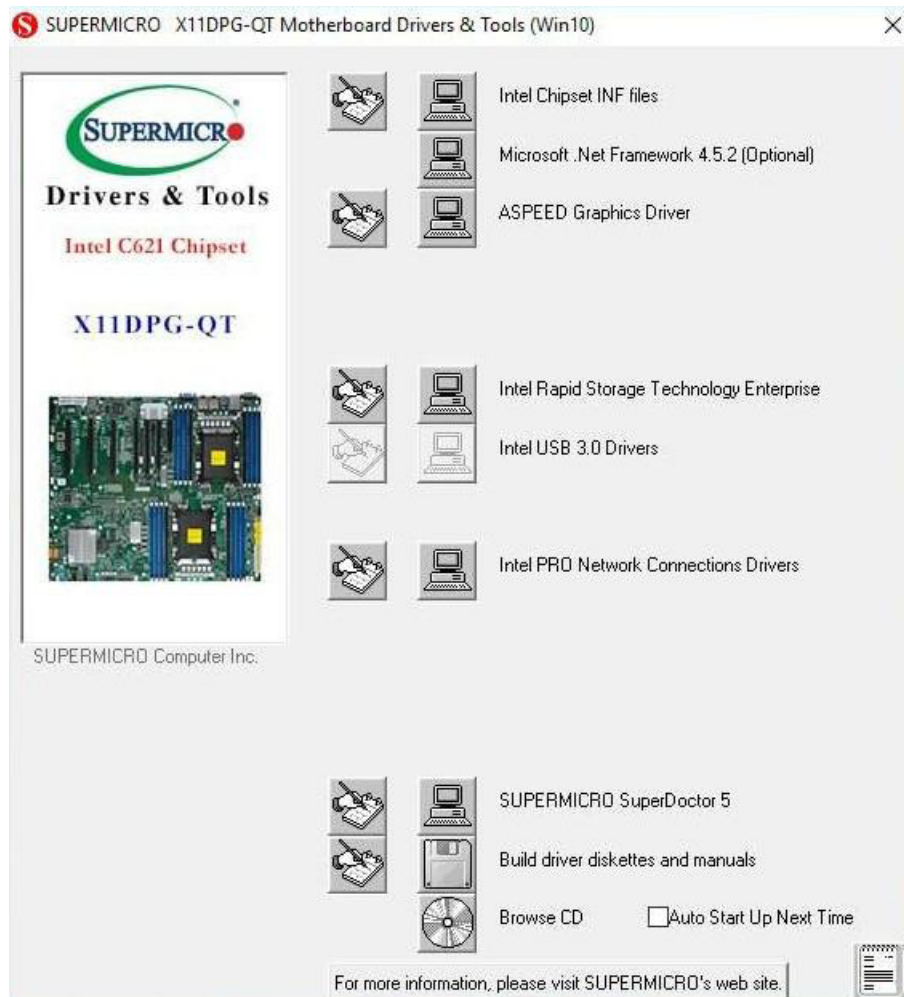

Figure 5-3. Driver & Tool Installation Screen

Note: Click the icons showing a hand writing on paper to view the readme files for each item. Click the computer icons to the right of these items to install each item (from top to the bottom) one at a time. **After installing each item, you must re-boot the system before moving on to the next item on the list.** The bottom icon with a CD on it allows you to view the entire contents.

5.3 SuperDoctor® 5

The Supermicro SuperDoctor 5 is a program that functions in a command-line or web-based interface for Windows and Linux operating systems. The program monitors such system health information as CPU temperature, system voltages, system power consumption, fan speed, and provides alerts via email or Simple Network Management Protocol (SNMP).

SuperDoctor 5 comes in local and remote management versions and can be used with Nagios to maximize your system monitoring needs. With SuperDoctor 5 Management Server (SSM Server), you can remotely control power on/off and reset chassis intrusion for multiple systems with SuperDoctor 5 or IPMI. SuperDoctor 5 Management Server monitors HTTP, FTP, and SMTP services to optimize the efficiency of your operation.

Note: The default User Name and Password for SuperDoctor 5 is ADMIN / ADMIN.

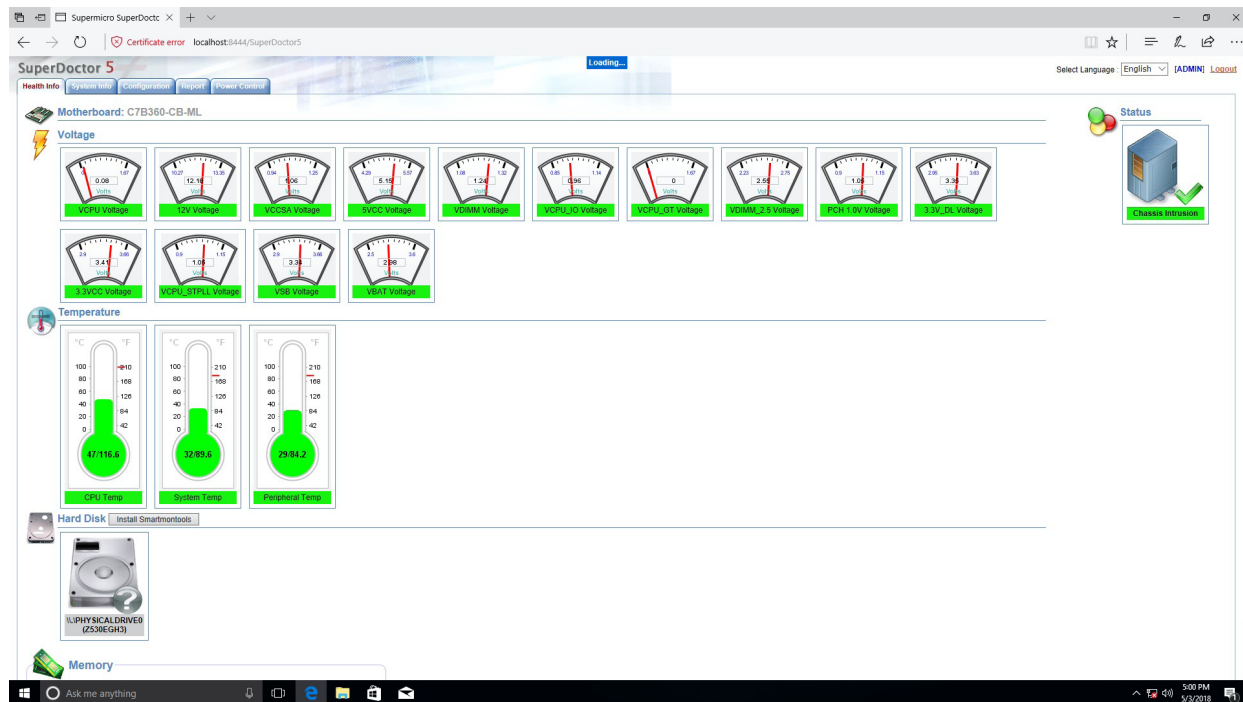

Figure 5-4. SuperDoctor 5 Interface Display Screen (Health Information)

5.4 IPMI

The X11DPG-QT supports the Intelligent Platform Management Interface (IPMI). IPMI provides remote access, monitoring and management through the baseboard management controller (BMC) and other management controllers distributed among different system modules. There are several BIOS settings that are related to IPMI. For general documentation and information on IPMI, visit our website at: <http://www.supermicro.com/products/nfo/IPMI.cfm>.

BMC ADMIN User Password

For security, each system is assigned a unique default BMC password for the ADMIN user. This can be found on a sticker on the chassis and a sticker on the motherboard. The sticker also displays the BMC MAC address.



Figure 5-5. BMC Password Label

See Chapter 1 for the locations of the labels.

Chapter 6

UEFI BIOS

6.1 Introduction

This chapter describes the AMIBIOS™ Setup utility for the X11DPG-QT motherboard. The is stored on a chip and can be easily upgraded using a flash program.

Note: Due to periodic changes to the BIOS, some settings may have been added or deleted and might not yet be recorded in this manual. Please refer to the Manual Download area of our website for any changes to BIOS that may not be reflected in this manual.

Starting the Setup Utility

To enter the BIOS Setup Utility, hit the <Delete> key while the system is booting up. (In most cases, the <Delete> key is used to invoke the BIOS setup screen. There are a few cases when other keys are used, such as <F1>, <F2>, etc.) Each main BIOS menu option is described in this manual.

The Main BIOS screen has two main frames. The left frame displays all the options that can be configured. "Grayed-out" options cannot be configured. The right frame displays the key legend. Above the key legend is an area reserved for a text message. When an option is selected in the left frame, it is highlighted in white. Often a text message will accompany it. (Note that BIOS has default text messages built in. We retain the option to include, omit, or change any of these text messages.) Settings printed in **Bold** are the default values.

A "►" indicates a submenu. Highlighting such an item and pressing the <Enter> key will open the list of settings within that submenu.

The BIOS setup utility uses a key-based navigation system called hot keys. Most of these hot keys (<F1>, <F10>, <Enter>, <ESC>, <Arrow> keys, etc.) can be used at any time during the setup navigation process.

6.2 Main Setup

When you first enter the AMI BIOS setup utility, you will enter the Main setup screen. You can always return to the Main setup screen by selecting the Main tab on the top of the screen. The Main BIOS setup screen is shown below. The following Main menu items will be displayed:

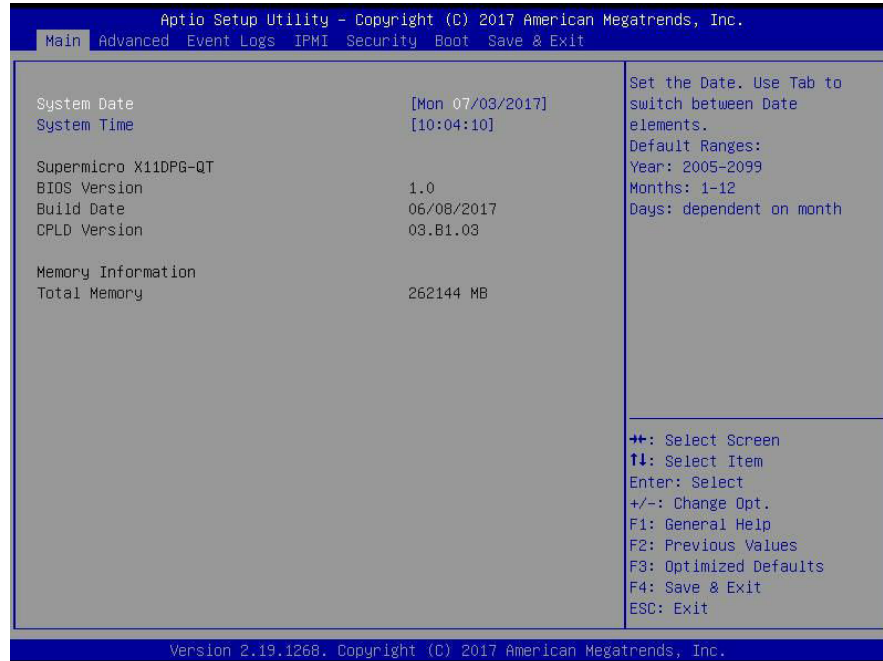

System Date/System Time

Use this option to change the system date and time. Highlight *System Date* or *System Time* using the arrow keys. Enter new values using the keyboard. Press the <Tab> key or the arrow keys to move between fields. The date must be entered in MM/DD/YYYY format. The time is entered in HH:MM:SS format.

Note: The time is in the 24-hour format. For example, 5:30 P.M. appears as 17:30:00. The date's default value is 01/01/2015 after RTC reset.

Supermicro X11DPG-QT

BIOS Version

This item displays the version of the BIOS ROM used in the system.

Build Date

This item displays the date when the version of the BIOS ROM used in the system was built.

CPLD Version

This item displays the Complex Programmable Logic Device version. Memory Information

Memory Information

Total Memory

This item displays the total size of memory available in the system.

6.3 Advanced Setup Configurations

Use the arrow keys to select Boot Setup and press <Enter> to access the submenu items.

Warning: Take caution when changing the Advanced settings. An incorrect value, a very high DRAM frequency, or an incorrect DRAM timing setting may make the system unstable. When this occurs, revert to the default to the manufacture default settings.

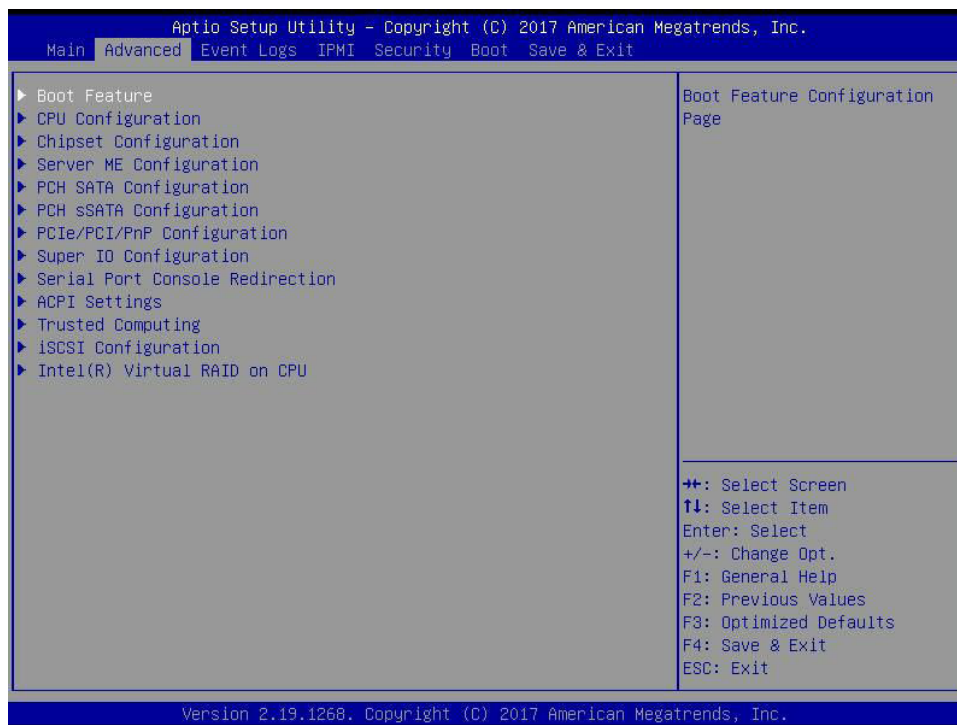

► Boot Feature

Quiet Boot

Use this feature to select the screen display between the POST messages and the OEM logo upon bootup. Select Disabled to display the POST messages. Select Enabled to display the OEM logo instead of the normal POST messages. The options are Disabled and **Enabled**.

Option ROM Messages

Use this feature to set the display mode for the Option ROM. Select Keep Current to display the current AddOn ROM setting. Select Force BIOS to use the Option ROM display set by the system BIOS. The options are **Force BIOS** and Keep Current.

Bootup NumLock State

Use this feature to set the Power-on state for the <Numlock> key. The options are **On** and Off.

Wait For "F1" If Error

Use this feature to force the system to wait until the 'F1' key is pressed if an error occurs. The options are Disabled and **Enabled**.

INT19 Trap Response

Interrupt 19 is the software interrupt that handles the boot disk function. When this item is set to Immediate, the ROM BIOS of the host adaptors will "capture" Interrupt 19 at bootup immediately and allow the drives that are attached to these host adaptors to function as bootable disks. If this item is set to Postponed, the ROM BIOS of the host adaptors will not capture Interrupt 19 immediately and allow the drives attached to these adaptors to function as bootable devices at bootup. The options are **Immediate** and Postponed.

Re-try Boot

If this item is enabled, the BIOS will automatically reboot the system from a specified boot device after its initial boot failure. The options are **Disabled**, Legacy Boot, and EFI Boot.

Install Windows 7 USB support

Enable this feature to use the USB keyboard and mouse during the Windows 7 installation, since the native XHCI driver support is unavailable. Use a SATA optical drive as a USB drive. USB CD/DVD drives are not supported. Disable this feature after the XHCI driver has been installed in Windows. The options are **Disabled** and Enabled.

Port 61h Bit-4 Emulation

Select Enabled to support the emulation of Port 61h bit-4 toggling in SMM (System Management Mode). The options are **Disabled** and Enabled.

Power Configuration

Watch Dog Function

If enabled, the Watch Dog Timer will allow the system to reset or generate NMI based on jumper settings when it is expired for more than 5 minutes. The options are **Disabled** and Enabled.

Restore on AC Power Loss

Use this feature to set the power state after a power outage. Select Stay-Off for the system power to remain off after a power loss. Select Power-On for the system power to be turned on after a power loss. Select Last State to allow the system to resume its last power state before a power loss. The options are Stay Off, Power On, and **Last State**.

Power Button Function

This feature controls how the system shuts down when the power button is pressed. Select 4 Seconds Override for the user to power off the system after pressing and holding the power button for 4 seconds or longer. Select Instant Off to instantly power off the system as soon as the user presses the power button. The options are **Instant Off** and 4 Seconds Override.

Throttle on Power Fail

Throttling improves reliability and reduces power consumption in the processor via automatic voltage control during processor idle states. Select Enabled to decrease the system power by throttling CPU frequency when one power supply is failed. The options are **Disabled** and Enabled.

►CPU Configuration

This submenu displays the information of the CPU as detected by the BIOS. It also allows the user to configuration CPU settings:

- Processor BSP Revision
- Processor Socket
- Processor ID
- Processor Frequency
- Processor Max Ration
- Processor Min Ration
- Microcode Revision
- L1 Cache RAM
- L2 Cache RAM
- L3 Cache RAM
- Processor 0 Version
- Processor 1 Version

Hyper-Threading [All] (Available when supported by the CPU)

Select Enabled to support Intel® Hyper-threading Technology to enhance CPU performance. The options are Disable and **Enable**.

Execute Disable Bit (Available if supported by the OS & the CPU)

Select Enable to enable the Execute-Disable Bit which will allow the processor to designate areas in the system memory where an application code can execute and where it cannot, thus preventing a worm or a virus from flooding illegal codes to overwhelm the processor or damage the system during an attack. (Please refer to Intel's website for more information.) The options are Disable and **Enable**.

Intel Virtualization Technology (Available when supported by the CPU)

Select Enable to use Intel® Virtualization Technology so that I/O device assignments will be reported directly to the VMM (Virtual Memory Management) through the DMAR ACPI Tables. This feature offers fully-protected I/O resource-sharing across the Intel® platforms, providing the user with greater reliability, security and availability in networking and data-sharing. The options are Disable and **Enable**.

Note: If a change is made to this setting, you will need to reboot the system for the change to take effect. Refer to Intel's website for detailed information.

PPIN Control

Select Unlock/Enable to use the Protected-Processor Inventory Number (PPIN) in the system. The options are Unlock/Disable and **Unlock/Enable**.

Hardware Prefetcher (Available when supported by the CPU)

If this item is set to Enable, the hardware prefetcher will prefetch streams of data and instructions from the main memory to the L2 cache to improve CPU performance. The options are **Enable** and Disable.

Adjacent Cache Prefetch (Available when supported by the CPU)

The CPU prefetches the cache line for 64 bytes if this feature is set to Disable. The CPU prefetches both cache lines for 128 bytes as comprised if this feature is set to **Enable**. The options are **Enable** and Disable.

DCU Streamer Prefetcher (Available when supported by the CPU)

Select Enabled to enable Intel® CPU Advanced Encryption Standard (AES) Instructions for CPU to enhance data integrity. The options are **Enable** and Disable.

DCU IP Prefetcher (Available when supported by the CPU)

If this feature is set to Enable, the DCU (Data Cache Unit) IP prefetcher will prefetch IP addresses in advance to improve network connectivity and system performance. The options are **Enable** and Disable.

LLC Prefetch

Select Enable to support the LLC prefetch on all threads. The options are **Disable** and Enable.

Extended APIC

Select Enable to use the extended APIC (Advanced Programmable Interrupt Control) support to enhance power management. The options are **Disable** and Enable.

AES-NI

Select Enable to use the Intel® Advanced Encryption Standard (AES) New Instructions (NI) to ensure data security. The options are Disable and **Enable**.

► **Advanced Power Management Configuration**

Power Technology

Use this item to enable power management features. The options are Disable, **Energy Efficient**, and Custom. Select Energy Efficient to support power-saving mode. Select Custom to customize system power settings. Select Disable to disable power-saving settings.

Power Performance Tuning (Available when Power Technology is set to Custom)

This feature allows the user to set whether the operating system or the BIOS controls the Energy Performance BIAS (EPB). The options are **OS Controls EPB** and BIOS Controls EPB.

ENERGY_PERF_BIAS_CFG Mode (Available when Power Performance Tuning is set to BIOS Controls EPB)

The Energy Performance BIAS (EPB) feature allows the user to configure CPU power and performance settings. Select Maximum Performance to set the highest performance. Select Performance to optimize performance over energy efficiency. Select Balanced Performance to prioritize performance optimization while conserving energy. Select Balanced Power to prioritize energy conservation while maintaining good performance. Select Power to optimize energy efficiency over performance. The options are Maximum Performance, Performance, **Balanced Performance**, Balanced Power, and Power.

► **CPU P State Control (Available when Power Technology is set to Custom)**

SpeedStep (Pstates)

EIST (Enhanced Intel® SpeedStep™ Technology) allows the system to automatically adjust processor voltage and core frequency to reduce power consumption and heat dissipation. The options are Disable and **Enable**.

EIST PSD Function

This feature allows the user to change the P-State (Power-Performance State) coordination type. P-State is also known as "SpeedStep" for Intel® processors. Select HW_ALL to change the P-State coordination type for all hardware components only. Select SW_ALL to change the P-State coordination type for all software installed in the system. Select SW_ANY to change the P-State coordination type for a particular software program specified by the user in the system. The options are **HW_ALL**, SW_ALL, and SW_ANY.

Turbo Mode (Available when Intel® EIST Technology is enabled)

Select Enable to use the Turbo Mode to boost system performance. The options are Disable and **Enable**.

► **Hardware PM State Control (Available when Power Technology is set to Custom)**

Hardware P-States

This feature enables the hardware P-States support. The options are **Disable**, Native Mode, Out of Band Mode, and Native Mode with No Legacy Support.

► **CPU C State Control (Available when Power Technology is set to Custom)**

Autonomous Core C-State

Use this feature to enable the autonomous core C-State control. The options are **Disable** and **Enable**.

CPU C6 report

Select **Enable** to allow the BIOS to report the CPU C6 State (ACPI C3) to the operating system. During the CPU C6 State, the power to all cache is turned off. The options are **Disable**, **Enable**, and **Auto**.

Enhanced Halt State (C1E)

Select **Enable** to use Enhanced Halt-State technology, which will significantly reduce the CPU's power consumption by reducing the CPU's clock cycle and voltage during a Halt-state. The options are **Disable** and **Enable**.

► **Package C State Control (Available when Power Technology is set to Custom)**

Package C State

This feature allows the user to set the limit on the C-State package register. The options are C0/C1 state, C2 state, C6 (non Retention) state, C6 (Retention) state, No Limit, and **Auto**.

► **CPU T State Control (Available when Power Technology is set to Custom)**

Software Controlled T-States

This feature enables the software controlled T-States support. The options are **Disable** and **Enable**

► Chipset Configuration

Warning: Setting the wrong values in the following features may cause the system to malfunction.

► North Bridge

This feature allows the user to configure the following North Bridge settings.

► UPI Configuration

UPI Configuration

The following information will be displayed:

- Number of CPU
- Number of IIO
- Current UPI Link Speed
- Current UPI Link Frequency
- UPI Global MMIO Low Base/Limit
- UPI Global MMIO High Base/Limit
- UPI Pci-e Configuration Base/Size

Degrade Precedence

Select Topology Precedence to degrade features if system options are in conflict. Select Feature Precedence to degrade topology if system options are in conflict. The options are Topology Precedence and Feature Precedence.

Link L0p Enable

Select Enable for the QPI to enter the L0p state for power saving. The options are Disable, Enable, and **Auto**.

Link L1 Enable

Select Enable for the QPI to enter the L1 state for power saving. The options are Disable, Enable, and **Auto**.

IO Directory Cache (IODC)

Use this feature to enable the IO Directory Cache (IODC) support. The options are Disable, **Auto**, Enable for Remote Invltom Hybrid Push, Invltom AllocFlow, Enable for Remote Invltom Hybrid AllocNonAlloc, and Enable for Remote Invltom and Remote WViLF.

SNC

Sub NUMA Clustering (SNC) is a feature that breaks up the Last Level Cache (LLC) into clusters based on address range. Each cluster is connected to a subset of the memory controller. Enabling SNC improves average latency and reduces memory access congestion to achieve higher performance. Select Auto for 1-cluster or 2-clusters depending on IMC interleave. Select Enable for Full SNC (2-clusters and 1-way IMC interleave). The options are **Disable**, Enable, and Auto.

XPT Prefetch

XPT Prefetch is a feature that speculatively makes a copy to the memory controller of a read request being sent to the LLC. If the read request maps to the local memory address and the recent memory reads are likely to miss the LLC, a speculative read is sent to the local memory controller. The options are Disable and **Enable**.

KTI Prefetch

KTI Prefetch is a feature that enables memory read to start early on a DDR bus, where the KTI Rx path will directly create a Memory Speculative Read command to the memory controller. The options are Disable and **Enable**.

Local/Remote Threshold

This feature allows the user to set the threshold for the Interrupt Request (IRQ) signal, which handles hardware interruptions. The options are Disable, **Auto**, Low, Medium, and High.

Stale AtoS

This feature optimizes A to S directory. When all snoop responses found in directory A are found to be Rspl, then all data is moved to directory S and is returned in S-state. The options are **Disable**, Enable, and Auto.

LLC Dead Line Alloc

Select Enable to optimally fill dead lines in LLC. Select Disable to never fill dead lines in LLC. The options are Disable, **Enable**, and Auto.

Isoc Mode

Select Enable to enable Isochronous support to meet QoS (Quality of Service) requirements. This feature is especially important for Virtualization Technology. The options are Disable, Enable, and **Auto**.

► Memory Configuration

Integrated Memory Controller (iMC)

Enforce POR

Select Enable to enforce POR restrictions on DDR4 frequency and voltage programming. The options are **POR** and Disable.

Memory Frequency

Use this feature to set the maximum memory frequency for onboard memory modules. The options are **Auto**, 1866, 2000, 2133, 2200, 2400, 2600, and 2666.

Data Scrambling for NVMDIMM

Select Enable to enable data scrambling to enhance system performance and data integrity. The options are **Auto**, Disable, and Enable.

Data Scrambling for DDR4

Use this feature to enable data scrambling for DDR4. The options are **Auto**, Disable, and Enable.

tCCD_L Relaxation

Select Auto to get TCDD settings from SPD (Serial Presence Detect) and implement into memory RC code to improve system reliability. Select Disable for TCCD to follow Intel POR. The options are Disable and **Auto**.

Enable ADR

Select Enable for ADR (Automatic Diagnostic Repository) support to enhance memory performance. The options are **Disable** and Enable.

2X Refresh Options

Use this item to select the 2X refresh mode. The options are **Auto** and Enable.

Page Policy

This feature allows the user to determine the desired page mode for IMC. When Auto is selected, the memory controller will close or open pages based on the current operation. Closed policy closes that page after reading or writing. Adaptive is similar to open page policy, but can be dynamically modified. The options are **Auto**, Closed, and Adaptive..

IMC Interleaving

This feature allows the user to configure Integrated Memory Controller (IMC) Interleaving settings. The options are **Auto**, 1-way Interleave, and 2-way Interleave.

► Memory Topology

The item displays the information of onboard memory modules as detected by the BIOS.

► Memory RAS (Reliability_Availability_Serviceability) Configuration

Memory RAS Configuration Setup

Use this submenu to configure the following Memory RAS settings.

Static Virtual Lockstep Mode

Select Enable to support the static virtual lockstep mode. The options are **Disable** and Enable.

Mirror Mode

Use this item to select the mirror mode. The options are **Disable**, Mirror Mode 1LM, and Mirror Mode 2LM. If this item is set to Mirror Mode 1LM or Mirror Mode 2LM, the available memory capacity will be reduced by 50 percent.

UEFI ARM Mirror

Select Enable to support the UEFI-based address range mirroring with setup option. The options are **Disable** and Enable.

Memory Rank Sparing

Select Enable to enable memory-sparing support for memory ranks to improve memory performance. The options are **Disable** and Enable.

**If the item above "Memory Rank Sparing" is set to Enable, the following item, "Multi Rank Sparing", will be available:*

Multi Rank Sparing

Use this feature to set the multiple rank sparing number. The default setting and the maximum is two ranks per channel. The options are One Rank and **Two Rank**.

Correctable Error Threshold

Use this item to enter the threshold value for correctable memory errors. The default setting is **10**.

SDDC Plus One

Single Device Data Correction (SDDC) allows data to be reconstructed when one of the memory devices fails on a DIMM. Use this feature to enable the SDDC support. The options are **Disable** and Enable.

ADDDC Sparing

Adaptive Double Device Data Correction (ADDDC) Sparing detects the predetermined threshold for correctable errors, copying the contents of the failing DIMM to spare memory. The failing DIMM or memory rank will then be disabled. The options are **Disable** and **Enable**.

Patrol Scrub

Patrol Scrubbing is a process that allows the CPU to correct correctable memory errors detected on a memory module and send the correction to the requestor (the original source). When this item is set to **Enable**, read-and-write will be performed every 16K cycles per cache line if there is no delay caused by internal processing. The options are **Disable** and **Enable**.

Patrol Scrub Interval

This feature allows you to decide how many hours the system should wait before the next complete patrol scrub is performed. Use the keyboard to enter a value from 0-24. The Default setting is **24**.

► IIO Configuration

IIO Configuration

EV DFX Features

When this feature is set to **Enable**, the EV_DFX Lock Bits that are located on a processor will always remain clear during electric tuning. The options are **Disable** and **Enable**.

► CPU1 Configuration

IOU0 (IIO PCIe Br1)

This item configures the PCIe port Bifurcation setting for a PCIe port specified by the user. The options are x4x4x4x4, x4x4x8, x8x4x4, x8x8, x16, and **Auto**.

IOU1 (IIO PCIe Br2)

This item configures the PCIe port Bifurcation setting for a PCIe port specified by the user. The options are x4x4x4x4, x4x4x8, x8x4x4, x8x8, x16, and **Auto**.

IOU2 (IIO PCIe Br3)

This item configures the PCIe port Bifurcation setting for a PCIe port specified by the user. The options are x4x4x4x4, x4x4x8, x8x4x4, x8x8, x16, and **Auto**.

► CPU1 SLOT2 PCI-E 3.0 x16**Link Speed**

Use this feature to select the link speed for the PCIe port. The options are **Auto**, Gen 1 (2.5 GT/s), Gen 2 (5 GT/s), and Gen 3 (8 GT/s).

PCI-E Port Link Status**PCI-E Port Link Max****PCI-E Port Link Speed****PCI-E Port Clocking**

The options are Distinct and **Common**. If this item is set to Distinct, this component and the component at the opposite end of the Link are operating with separate reference clock sources. If this item is set to Common, this component and the component at the opposite end of the Link are operating with a common clock source.

PCI-E Port Max Payload Size

Select Auto for the system BIOS to automatically set the maximum payload value for a PCIe device to enhance system performance. The options are 128B, 256B, and **Auto**.

► CPU1 SLOT4 PCI-E 3.0 x16**Link Speed**

Use this feature to select the link speed for the PCIe port. The options are **Auto**, Gen 1 (2.5 GT/s), Gen 2 (5 GT/s), and Gen 3 (8 GT/s).

PCI-E Port Link Status**PCI-E Port Link Max****PCI-E Port Link Speed****PCI-E Port Clocking**

The options are Distinct and **Common**. If this item is set to Distinct, this component and the component at the opposite end of the Link are operating with separate reference clock sources. If this item is set to Common, this component and the component at the opposite end of the Link are operating with a common clock source.

PCI-E Port Max Payload Size

Select Auto for the system BIOS to automatically set the maximum payload value for a PCIe device to enhance system performance. The options are 128B, 256B, and **Auto**.

► CPU1 SLOT9 PCI-E 3.0 x16

Link Speed

Use this feature to select the link speed for the PCIe port. The options are **Auto**, Gen 1 (2.5 GT/s), Gen 2 (5 GT/s), and Gen 3 (8 GT/s).

PCI-E Port Link Status

PCI-E Port Link Max

PCI-E Port Link Speed

PCI-E Port Clocking

The options are Distinct and **Common**. If this item is set to Distinct, this component and the component at the opposite end of the Link are operating with separate reference clock sources. If this item is set to Common, this component and the component at the opposite end of the Link are operating with a common clock source.

PCI-E Port Max Payload Size

Select Auto for the system BIOS to automatically set the maximum payload value for a PCIe device to enhance system performance. The options are 128B, 256B, and **Auto**.

► CPU2 Configuration

IOU0 (IIO PCIe Br1)

This item configures the PCIe port Bifurcation setting for a PCIe port specified by the user. The options are x4x4x4x4, x4x4x8, x8x4x4, x8x8, x16, and **Auto**.

IOU1 (IIO PCIe Br2)

This item configures the PCIe port Bifurcation setting for a PCIe port specified by the user. The options are x4x4x4x4, x4x4x8, x8x4x4, x8x8, x16, and **Auto**.

IOU2 (IIO PCIe Br3)

This item configures the PCIe port Bifurcation setting for a PCIe port specified by the user. The options are x4x4x4x4, x4x4x8, x8x4x4, x8x8, x16, and **Auto**.

► CPU2 SLOT6 PCI-E 3.0 x16

Link Speed

Use this feature to select the link speed for the PCIe port. The options are **Auto**, Gen 1 (2.5 GT/s), Gen 2 (5 GT/s), and Gen 3 (8 GT/s).

PCI-E Port Link Status**PCI-E Port Link Max****PCI-E Port Link Speed****PCI-E Port Clocking**

The options are Distinct and **Common**. If this item is set to Distinct, this component and the component at the opposite end of the Link are operating with separate reference clock sources. If this item is set to Common, this component and the component at the opposite end of the Link are operating with a common clock source.

PCI-E Port Max Payload Size

Select Auto for the system BIOS to automatically set the maximum payload value for a PCIe device to enhance system performance. The options are 128B, 256B, and **Auto**.

► CPU2 SLOT8 PCI-E 3.0 x16**Link Speed**

Use this feature to select the link speed for the PCIe port. The options are **Auto**, Gen 1 (2.5 GT/s), Gen 2 (5 GT/s), and Gen 3 (8 GT/s).

PCI-E Port Link Status**PCI-E Port Link Max****PCI-E Port Link Speed****PCI-E Port Clocking**

The options are Distinct and **Common**. If this item is set to Distinct, this component and the component at the opposite end of the Link are operating with separate reference clock sources. If this item is set to Common, this component and the component at the opposite end of the Link are operating with a common clock source.

PCI-E Port Max Payload Size

Select Auto for the system BIOS to automatically set the maximum payload value for a PCIe device to enhance system performance. The options are 128B, 256B, and **Auto**.

► CPU2 SLOT10 PCI-E 3.0 x16

Link Speed

Use this feature to select the link speed for the PCIe port. The options are **Auto**, Gen 1 (2.5 GT/s), Gen 2 (5 GT/s), and Gen 3 (8 GT/s).

PCI-E Port Link Status

PCI-E Port Link Max

PCI-E Port Link Speed

PCI-E Port Clocking

The options are Distinct and **Common**. If this item is set to Distinct, this component and the component at the opposite end of the Link are operating with separate reference clock sources. If this item is set to Common, this component and the component at the opposite end of the Link are operating with a common clock source.

PCI-E Port Max Payload Size

Select Auto for the system BIOS to automatically set the maximum payload value for a PCIe device to enhance system performance. The options are 128B, 256B, and **Auto**.

► IOAT (Intel® IO Acceleration) Configuration

Disable TPH

Select Yes to deactivate TLP Processing Hint support. The options are **No** and Yes.

Prioritize TPH

Use this feature to enable the prioritize TPH support. The options are Enable and **Disable**.

Relaxed Ordering

Select Enable to enable Relaxed Ordering support which will allow certain transactions to violate the strict-ordering rules of PCI bus for a transaction to be completed prior to other transactions that have already been queued. The options are **Disable** and Enable.

► Intel® VT for Directed I/O (VT-d)

Intel® VT for Directed I/O (VT-d)

Select Enable to use Intel® Virtualization Technology support for Direct I/O VT-d support by reporting the I/O device assignments to the VMM (Virtual Machine Monitor) through the DMAR ACPI Tables. This feature offers fully-protected I/O resource sharing across Intel® platforms, providing greater reliability, security and availability in networking and data-sharing. The options are **Enable** and Disable.

**If the item above is set to Enable, the following items will be available:*

Interrupt Remapping

Select Enable for Interrupt Remapping support to enhance system performance. The options are **Enable** and Disable.

PassThrough DMA

Select Enable to use the Non-Isoch VT_D engine pass through DMA support. The options are **Enable** and Disable.

ATS

Select Enable to use the Non-Isoch VT_D engine ATS support. The options are **Enable** and Disable.

Posted Interrupt

Use this feature to enable VT_D posted interrupt. The options are **Enable** and Disable.

Coherency Support (Non-Isoch)

Select Enable for the Non-Isoch VT-d engine to pass through DMA (Direct Memory Access) to enhance system performance. The options are **Enable** and Disable.

► Intel® VMD technology

The Intel® Volume Management Device (VMD) is a host bridge to a secondary PCIe domain to provide more bus resources.

► Intel® VMD for Volume Management Device on CPU1

VMD Config for PStack0

Intel® VMD for Volume Management Device

Select Enable to use the Intel® Volume Management Device Technology for this stack. The options are **Disable** and Enable.

**If the item above "Intel® VMD for Volume Management Device" is set to Enable, the following items will be displayed:*

CPU1 SLOT2 PCI-E 3.0 x16 VMD (Available when the device is detected by the system)

Select Enable to use the Intel® Volume Management Device Technology for this device. The options are **Disable** and Enable.

Hot Plug Capable (Available when the device is detected by the system)

Use this feature to enable the hot plug support for PCIe root ports 1A~1D. The options are **Disable** and Enable.

VMD Config for PStack1

Intel® VMD for Volume Management Device

Select Enable to use the Intel® Volume Management Device Technology for this stack. The options are **Disable** and Enable.

**If the item above "Intel® VMD for Volume Management Device" is set to Enable, the following items will be displayed:*

CPU1 SLOT4 PCI-E 3.0 x16 VMD (Available when the device is detected by the system)

Select Enable to use the Intel® Volume Management Device Technology for this device. The options are **Disable** and Enable.

Hot Plug Capable (Available when the device is detected by the system)

Use this feature to enable the hot plug support for PCIe root ports 2A~2D. The options are **Disable** and Enable.

VMD Config for PStack2

Intel® VMD for Volume Management Device

Select Enable to use the Intel® Volume Management Device Technology for this stack. The options are **Disable** and Enable.

**If the item above "Intel® VMD for Volume Management Device" is set to Enable, the following items will be displayed:*

CPU1 SLOT9 PCI-E 3.0 x16 VMD (Available when the device is detected by the system)

Select Enable to use the Intel® Volume Management Device Technology for this device. The options are **Disable** and Enable.

Hot Plug Capable (Available when the device is detected by the system)

Use this feature to enable the hot plug support for PCIe root ports 3A~3D. The options are **Disable** and Enable.

► Intel® VMD for Volume Management Device on CPU2

VMD Config for PStack0

Intel® VMD for Volume Management Device

Select Enable to use the Intel® Volume Management Device Technology for this stack. The options are **Disable** and Enable.

**If the item above "Intel® VMD for Volume Management Device" is set to Enable, the following items will be displayed:*

CPU2 SLOT6 PCI-E 3.0 x16 VMD (Available when the device is detected by the system)

Select Enable to use the Intel® Volume Management Device Technology for this device. The options are **Disable** and Enable.

Hot Plug Capable (Available when the device is detected by the system)

Use this feature to enable the hot plug support for PCIe root ports 1A~1D. The options are **Disable** and Enable.

VMD Config for PStack1

Intel® VMD for Volume Management Device

Select Enable to use the Intel® Volume Management Device Technology for this stack. The options are **Disable** and Enable.

**If the item above "Intel® VMD for Volume Management Device" is set to Enable, the following items will be displayed:*

CPU2 SLOT8 PCI-E 3.0 x16 VMD (Available when the device is detected by the system)

Select Enable to use the Intel® Volume Management Device Technology for this device. The options are **Disable** and Enable.

Hot Plug Capable (Available when the device is detected by the system)

Use this feature to enable the hot plug support for PCIe root ports 2A~2D. The options are **Disable** and Enable.

VMD Config for PStack2

Intel® VMD for Volume Management Device

Select Enable to use the Intel® Volume Management Device Technology for this stack. The options are **Disable** and Enable.

**If the item above "Intel® VMD for Volume Management Device" is set to Enable, the following items will be displayed:*

CPU2 SLOT10 PCI-E 3.0 x16 VMD (Available when the device is detected by the system)

Select Enable to use the Intel® Volume Management Device Technology for this device. The options are **Disable** and Enable.

Hot Plug Capable (Available when the device is detected by the system)

Use this feature to enable the hot plug support for PCIe root ports 3A~3D. The options are **Disable** and Enable.

IIO-PCIE Express Global Options

PCI-E Completion Timeout Disable

Use this feature for PCIe Completion Timeout support for electric tuning. The options are Yes, **No**, and Per-Port.

▶ **South Bridge**

The following South Bridge information will be displayed:

- USB Module Version
- USB Devices

Legacy USB Support

Select Enabled to support onboard legacy USB devices. Select Auto to disable legacy support if there are no legacy USB devices present. Select Disable to have all USB devices available for EFI applications only. The options are **Enabled**, Disabled, and Auto.

XHCI Hand-off

This is a work-around solution for operating systems that do not support XHCI (Extensible Host Controller Interface) hand-off. The XHCI ownership change should be claimed by the XHCI driver. The options are Enabled and **Disabled**.

Port 60/64 Emulation

Select Enabled for I/O port 60h/64h emulation support, which will provide complete legacy USB keyboard support for the operating systems that do not support legacy USB devices. The options are Disabled and **Enabled**.

PCIE PLL SSC

Use this feature to enable PCIe Phase-locked Loop (PLL) Spread Spectrum Clocking (SSC). The options are **Disable** and Enable.

Real USB Wake Up

Select Enabled to enable the wake-up function of the USB port. The options are Disabled and **Enabled**.

Front USB Wake Up

Select Enabled to enable the wake-up function of the front access USB port. The options are Disabled and **Enabled**.

Azalia

Select Enabled to enable support for Azalia High Definition Audio. The options are Disabled, Enabled, and **Auto**.

Azalia PME Enable

Select Enabled to enable power management capability of the Azalia controller. The options are **Disabled** and Enabled.

► Server ME Configuration

This feature displays the following system ME configuration settings.

- Operational Firmware Version
- Backup Firmware Version
- Recovery Firmware Version
- ME Firmware Status #1
- ME Firmware Status #2
 - Current State
 - Error Code

► PCH SATA Configuration**SATA Controller**

This item enables or disables the onboard SATA controller supported by the Intel® PCH chip. The options are Disable and **Enable**.

Configure SATA as

Select AHCI to configure a SATA drive specified by the user as an AHCI drive. Select RAID to configure a SATA drive specified by the user as a RAID drive. The options are **AHCI** and RAID.

SATA HDD Unlock

Select Enable to unlock the HDD password. The options are Disable and **Enable**.

Aggressive Link Power Management

When this item is set to Enable, the SATA AHCI controller manages the power usage of the SATA link. The controller will put the link to a low power state when the I/O is inactive for an extended period of time, and the power state will return to normal when the I/O becomes active. The options are **Disable** and Enable.

****If the item above "Configure SATA as" is set to AHCI, the following items will be displayed:***

SATA Port 0~ Port 7

This item displays the information detected on the installed SATA drive on the particular SATA port.

- Model number of drive and capacity
- Software Preserve Support

Hot Plug (SATA Port 0~ Port 7)

Select Enabled to enable a SATA port specified by the user. The options are Disable and **Enable**.

Spin Up Device (SATA Port 0~ Port 7)

On an edge detect from 0 to 1, set this item to allow the PCH to initialize the device. The options are **Disable** and Enable.

SATA Device Type (SATA Port 0~ Port 7)

Use this item to specify if the SATA port specified by the user should be connected to a Solid State drive or a Hard Disk Drive. The options are **Hard Disk Drive** and Solid State Drive.

****If the item above "Configure SATA as" is set to RAID, the following items will be displayed:***

SATA HDD Unlock

Select Enable to unlock the HDD password. The options are Disable and **Enable**.

Aggressive Link Power Management

When this item is set to Enable, the SATA Raid controller manages the power usage of the SATA link. The controller will put the link to a low power state when the I/O is inactive for an extended period of time, and the power state will return to normal when the I/O becomes active. The options are **Disable** and Enable.

SATA RSTe Boot Info

Select Enable to provide the full int13h support for SATA controller attached devices. The options are Disable and **Enable**.

SATA RAID Option ROM/UEFI Driver

Select EFI to load the EFI driver for system boot. Select Legacy to load a legacy driver for system boot. The options are Disable, EFI, and **Legacy**.

SATA Port 0~ Port 7

This item displays the information detected on the installed SATA drive on the particular SATA port.

- Model number of drive and capacity
- Software Preserve Support

Hot Plug (SATA Port 0~ Port 7)

Select Enabled to enable a SATA port specified by the user. The options are Disable and **Enable**.

Spin Up Device (SATA Port 0~ Port 7)

On an edge detect from 0 to 1, set this item to allow the PCH to initialize the device. The options are **Disable** and Enable.

SATA Device Type (SATA Port 0~ Port 7)

Use this item to specify if the SATA port specified by the user should be connected to a Solid State drive or a Hard Disk Drive. The options are **Hard Disk Drive** and Solid State Drive.

►PCH sSATA Configuration**sSATA Controller**

This item enables or disables the onboard SATA controller supported by the Intel® PCH chip. The options are **Enable** and Disable.

Configure sSATA as

Select AHCI to configure a SATA drive specified by the user as an AHCI drive. Select RAID to configure a SATA drive specified by the user as a RAID drive. The options are **AHCI** and RAID.

SATA HDD Unlock

Select Enable to unlock the HDD password. The options are Disable and **Enable**.

Aggressive Link Power Management

When this item is set to Enable, the SATA AHCI controller manages the power usage of the SATA link. The controller will put the link to a low power state when the I/O is inactive for an extended period of time, and the power state will return to normal when the I/O becomes active. The options are **Disable** and Enable.

****If the item above "Configure sSATA as" is set to AHCI, the following items will be displayed:***

sSATA Port 0~ Port 1

This item displays the information detected on the installed SATA drive on the particular SATA port.

- Model number of drive and capacity
- Software Preserve Support

Hot Plug (sSATA Port 0~ Port 1)

Select Enabled to enable a SATA port specified by the user. The options are **Disable** and **Enable**.

Spin Up Device (sSATA Port 0~ Port 1)

On an edge detect from 0 to 1, set this item to allow the PCH to initialize the device. The options are **Disable** and Enable.

sSATA Device Type (sSATA Port 0~ Port 1)

Use this item to specify if the SATA port specified by the user should be connected to a Solid State drive or a Hard Disk Drive. The options are **Hard Disk Drive** and Solid State Drive.

****If the item above "Configure SATA as" is set to RAID, the following items will be displayed:***

SATA HDD Unlock

Select Enable to unlock the HDD password. The options are **Disable** and **Enable**.

Aggressive Link Power Management

When this item is set to Enable, the SATA Raid controller manages the power usage of the SATA link. The controller will put the link to a low power state when the I/O is inactive for an extended period of time, and the power state will return to normal when the I/O becomes active. The options are **Disable** and Enable.

sSATA RSTe Boot Info

Select Enable to provide the full int13h support for SATA controller attached devices. The options are **Disable** and **Enable**.

sSATA RAID Option ROM/UEFI Driver

Select EFI to load the EFI driver for system boot. Select Legacy to load a legacy driver for system boot. The options are Disable, EFI, and **Legacy**.

sSATA Port 0~ Port 1

This item displays the information detected on the installed SATA drive on the particular SATA port.

- Model number of drive and capacity
- Software Preserve Support

Hot Plug (sSATA Port 0~ Port 1)

Select Enabled to enable a SATA port specified by the user. The options are Disable and **Enable**.

Spin Up Device (sSATA Port 0~ Port 1)

On an edge detect from 0 to 1, set this item to allow the PCH to initialize the device. The options are **Disable** and Enable.

sSATA Device Type (sSATA Port 0~ Port 1)

Use this item to specify if the SATA port specified by the user should be connected to a Solid State drive or a Hard Disk Drive. The options are **Hard Disk Drive** and Solid State Drive.

► PCIe/PCI/PnP Configuration

The following information will be displayed:

- PCI Bus Driver Version

PCI Devices Common Settings:**Above 4G Decoding (Available if the system supports 64-bit PCI decoding)**

Select Enabled to decode a PCI device that supports 64-bit in the space above 4G Address. The options are Disabled and **Enabled**.

SR-IOV Support

Use this feature to enable or disable Single Root IO Virtualization support. The options are **Disabled** and Enabled.

MMIO High Base

Use this item to select the base memory size according to memory-address mapping for the IO hub. The base memory size must be between 4032G to 4078G. The options are **56T**, 40T, 24T, 16T, 4T, and 1T.

MMIO High Granularity Size

Use this item to select the high memory size according to memory-address mapping for the IO hub. The options are 1G, 4G, 16G, 64G, **256G**, and 1024G.

PCI PERR/SERR Support

Select Enabled to activate PCI Error and System Error report handling. The options are **Disabled** and Enabled.

Maximum Read Request

Select Auto to allow the system BIOS to automatically set the maximum read request size for a PCIe device to enhance system performance. The options are **Auto**, 128 Bytes, 256 Bytes, 512 Bytes, 1024 Bytes, 2048 Bytes, and 4096 Bytes.

MMCFG Base

Use this feature to select the default value for the PCI MMIO (Memory-Mapped IO) base address. The options are 1G, 1.5G, 1.75G, **2G**, 2.25G, and 3G.

NVMe Firmware Source

Use this item to select the NVMe firmware to support booting. The options are **Vendor Defined Firmware** and AMI Native Support. The default option, **Vendor Defined Firmware**, is pre-installed on the drive and may resolve errata or enable innovative functions for the drive. The other option, AMI Native Support, is offered by the BIOS with a generic method.

VGA Priority

Use this item to select the graphics device to be used as the primary video display for system boot. The options are **Onboard** and Offboard.

CPU1 SLOT2 PCI-E 3.0 x16 OPROM, CPU1 SLOT4 PCI-E 3.0 x16 OPROM, CPU2 SLOT6 PCI-E 3.0 x16 OPROM, CPU2 SLOT8 PCI-E 3.0 x16 OPROM, CPU1 SLOT9 PCI-E 3.0 x16 OPROM, CPU2 SLOT10 PCI-E 3.0 x16 OPROM, CPU2 SLOT11 PCI-E 3.0 x4 (IN x8) OPROM

Select Disabled to deactivate the selected slot, Legacy to activate the slot in legacy mode, and EFI to activate the slot in EFI mode. The options are Disabled, **Legacy**, and EFI.

M.2 CONNECTOR OPROM

The options are Disabled, **Legacy**, and EFI. Select Disabled to deactivate the M.2 connector, Legacy to activate the slot in legacy mode, and EFI to activate the slot in EFI mode.

Onboard LAN1 Option ROM, Onboard LAN2 Option ROM

Use the two items to select the type of device installed in a LAN port specified by the user for system boot. The default setting for Onboard LAN1 Option ROM is **Legacy**, and the default setting for Onboard LAN2 Option ROM is **Disabled**.

Onboard Video Option ROM

Select Legacy to boot the system using a legacy video device installed on the motherboard. The options are Disabled, **Legacy**, and EFI.

► Network Stack Configuration

Network Stack

Select Enabled to enable UEFI (Unified Extensible Firmware Interface) for network stack support. The options are Disabled and **Enabled**.

**If the item above "Network Stack" is set to Enabled, the following items will be displayed:*

Ipv4 PXE Support

Select Enabled to enable Ipv4 PXE boot support. The options are Disabled and **Enabled**.

Ipv4 HTTP Support

Select Enabled to enable Ipv4 HTTP boot support. The options are **Disabled** and Enabled.

Ipv6 PXE Support

Select Enabled to enable Ipv6 PXE boot support. The options are Disabled and **Enabled**.

Ipv6 HTTP Support

Select Enabled to enable Ipv6 HTTP boot support. The options are **Disabled** and Enabled.

PXE boot wait time

Use this option to specify the wait time to press the ESC key to abort the PXE boot. Press "+" or "-" on your keyboard to change the value. The default setting is **0**.

Media detect count

Use this option to specify the number of times media will be checked. Press "+" or "-" on your keyboard to change the value. The default setting is **1**.

► Super IO Configuration

Super IO Configuration

The following Super IO information will be displayed:

- Super IO Chip AST2500

► Serial Port 1 Configuration

Serial Port 1 Configuration

This submenu allows the user the configure settings of Serial Port 1.

Serial Port 1

Select Enabled to enable the selected onboard serial port. The options are Disabled and Enabled.

Device Settings

This item displays the status of a serial part specified by the user.

Change Settings

This feature specifies the base I/O port address and the Interrupt Request address of a serial port specified by the user. Select Auto to allow the BIOS to automatically assign the base I/O and IRQ address. The options are **Auto**, (IO=3F8h; IRQ=4;), (IO=3F8h; IRQ=3, 4, 5, 6, 7, 9, 10, 11, 12;), (IO=2F8h; IRQ=3, 4, 5, 6, 7, 9, 10, 11, 12;), (IO=3E8h; IRQ=3, 4, 5, 6, 7, 9, 10, 11, 12;), and (IO=2E8h; IRQ=3, 4, 5, 6, 7, 9, 10, 11, 12;).

► Serial Port 2 Configuration

Serial Port 2 Configuration

This submenu allows the user the configure settings of Serial Port 2.

Serial Port 2

Select Enabled to enable the selected onboard serial port. The options are Disabled and Enabled.

Device Settings

This item displays the status of a serial part specified by the user.

Change Settings

This feature specifies the base I/O port address and the Interrupt Request address of a serial port specified by the user. Select Auto to allow the BIOS to automatically assign the base I/O and IRQ address. The options are **Auto**, (IO=2F8h; IRQ=3;), (IO=3F8h; IRQ=3, 4, 5, 6, 7, 9, 10, 11, 12;), (IO=2F8h; IRQ=3, 4, 5, 6, 7, 9, 10, 11, 12;), (IO=3E8h; IRQ=3, 4, 5, 6, 7, 9, 10, 11, 12;), and (IO=2E8h; IRQ=3, 4, 5, 6, 7, 9, 10, 11, 12;).

Serial Port 2 Attribute (Available for Serial Port 2 only)

Select SOL to use COM Port 2 as a Serial Over LAN (SOL) port for console redirection. The options are **SOL** and COM.

► Serial Port Console Redirection

COM1

Console Redirection

Select Enabled to enable console redirection support for a serial port specified by the user. The options are **Disabled** and Enabled.

**If the item above is set to Enabled, the following items will become available for user's configuration:*

► Console Redirection Settings

This feature allows the user to specify how the host computer will exchange data with the client computer, which is the remote computer used by the user.

COM1

Console Redirection Settings

Terminal Type

This feature allows the user to select the target terminal emulation type for Console Redirection. Select VT100 to use the ASCII Character set. Select VT100+ to add color and function key support. Select ANSI to use the Extended ASCII Character Set. Select VT-UTF8 to use UTF8 encoding to map Unicode characters into one or more bytes. The options are VT100, **VT100+**, VT-UTF8, and ANSI.

Bits Per second

Use this feature to set the transmission speed for a serial port used in Console Redirection. Make sure that the same speed is used in the host computer and the client computer. A lower transmission speed may be required for long and busy lines. The options are 9600, 19200, 38400, 57600, and **115200** (bits per second).

Data Bits

Use this feature to set the data transmission size for Console Redirection. The options are 7 and 8.

Parity

A parity bit can be sent along with regular data bits to detect data transmission errors. Select Even if the parity bit is set to 0, and the number of 1's in data bits is even. Select Odd if the parity bit is set to 0, and the number of 1's in data bits is odd. Select None if you do not want to send a parity bit with your data bits in transmission. Select Mark to add a mark as a parity bit to be sent along with the data bits. Select Space to add a Space as a parity bit to be sent with your data bits. The options are **None**, Even, Odd, Mark, and Space.

Stop Bits

A stop bit indicates the end of a serial data packet. Select 1 Stop Bit for standard serial data communication. Select 2 Stop Bits if slower devices are used. The options are **1** and **2**.

Flow Control

Use this feature to set the flow control for Console Redirection to prevent data loss caused by buffer overflow. Send a "Stop" signal to stop sending data when the receiving buffer is full. Send a "Start" signal to start sending data when the receiving buffer is empty. The options are **None** and Hardware RTS/CTS.

VT-UTF8 Combo Key Support

Select Enabled to enable VT-UTF8 Combination Key support for ANSI/VT100 terminals. The options are Disabled and **Enabled**.

Recorder Mode

Select Enabled to capture the data displayed on a terminal and send it as text messages to a remote server. The options are **Disabled** and Enabled.

Resolution 100x31

Select Enabled for extended-terminal resolution support. The options are Disabled and **Enabled**.

Legacy OS Redirection Resolution

Use this feature to select the number of rows and columns used in Console Redirection for legacy OS support. The options are **80x24** and 80x25.

Putty KeyPad

This feature selects the settings for the function keys and the key pad used for Putty, which is a terminal emulator designed for the Windows OS. The options are **VT100**, LINUX, XTERMR6, SC0, ESCN, and VT400.

Redirection After BIOS POST

Use this feature to enable or disable legacy console redirection after BIOS POST. When this feature is set to BootLoader, legacy console redirection is disabled before booting the OS. When this feature is set to Always Enable, legacy console redirection remains enabled when booting the OS. The options are **Always Enable** and BootLoader.

SOL/COM2

Console Redirection

Select Enabled to enable console redirection support for a serial port specified by the user. The options are Disabled and **Enabled**.

**If the item above is set to Enabled, the following items will become available for user's configuration:*

► Console Redirection Settings

This feature allows the user to specify how the host computer will exchange data with the client computer, which is the remote computer used by the user.

SOL/COM2

Console Redirection Settings

Terminal Type

This feature allows the user to select the target terminal emulation type for Console Redirection. Select VT100 to use the ASCII Character set. Select VT100+ to add color and function key support. Select ANSI to use the Extended ASCII Character Set. Select VT-UTF8 to use UTF8 encoding to map Unicode characters into one or more bytes. The options are VT100, **VT100+**, VT-UTF8, and ANSI.

Bits Per second

Use this feature to set the transmission speed for a serial port used in Console Redirection. Make sure that the same speed is used in the host computer and the client computer. A lower transmission speed may be required for long and busy lines. The options are 9600, 19200, 38400, 57600, and **115200** (bits per second).

Data Bits

Use this feature to set the data transmission size for Console Redirection. The options are 7 and **8**.

Parity

A parity bit can be sent along with regular data bits to detect data transmission errors. Select Even if the parity bit is set to 0, and the number of 1's in data bits is even. Select Odd if the parity bit is set to 0, and the number of 1's in data bits is odd. Select None if you do not want to send a parity bit with your data bits in transmission. Select Mark to add a mark as a parity bit to be sent along with the data bits. Select Space to add a Space as a parity bit to be sent with your data bits. The options are **None**, Even, Odd, Mark, and Space.

Stop Bits

A stop bit indicates the end of a serial data packet. Select 1 Stop Bit for standard serial data communication. Select 2 Stop Bits if slower devices are used. The options are **1** and 2.

Flow Control

Use this feature to set the flow control for Console Redirection to prevent data loss caused by buffer overflow. Send a "Stop" signal to stop sending data when the receiving buffer

is full. Send a "Start" signal to start sending data when the receiving buffer is empty. The options are **None** and Hardware RTS/CTS.

VT-UTF8 Combo Key Support

Select Enabled to enable VT-UTF8 Combination Key support for ANSI/VT100 terminals. The options are Disabled and **Enabled**.

Recorder Mode

Select Enabled to capture the data displayed on a terminal and send it as text messages to a remote server. The options are **Disabled** and Enabled.

Resolution 100x31

Select Enabled for extended-terminal resolution support. The options are Disabled and **Enabled**.

Legacy OS Redirection Resolution

Use this feature to select the number of rows and columns used in Console Redirection for legacy OS support. The options are **80x24** and 80x25.

Putty KeyPad

This feature selects the settings for the function keys and the key pad used for Putty, which is a terminal emulator designed for the Windows OS. The options are **VT100**, LINUX, XTERMR6, SC0, ESCN, and VT400.

Redirection After BIOS POST

Use this feature to enable or disable legacy console redirection after BIOS POST. When this feature is set to BootLoader, legacy console redirection is disabled before booting the OS. When this feature is set to Always Enable, legacy console redirection remains enabled when booting the OS. The options are **Always Enable** and BootLoader.

Legacy Console Redirection

Legacy Serial Redirection Port

Use the feature to select the COM port to display redirection of Legacy OS and Legacy OPROM messages. The options are **COM1** and SOL/COM2.

Serial Port for Out-of-Band Management/Windows Emergency Management Services (EMS)

The submenu allows the user to configure Console Redirection settings to support Out-of-Band Serial Port management.

Console Redirection

Select Enabled to use a COM port selected by the user for EMS Console Redirection. The options are **Disabled** and Enabled.

**If the item above is set to Enabled, the following items will become available for user's configuration:*

► Console Redirection Settings

This feature allows the user to specify how the host computer will exchange data with the client computer, which is the remote computer used by the user.

Out-of-Band Management Port

The feature selects a serial port in a client server to be used by the Windows Emergency Management Services (EMS) to communicate with a remote host server. The options are **COM1** and SOL/COM2.

Terminal Type

Use this feature to select the target terminal emulation type for Console Redirection. Select VT100 to use the ASCII character set. Select VT100+ to add color and function key support. Select ANSI to use the extended ASCII character set. Select VT-UTF8 to use UTF8 encoding to map Unicode characters into one or more bytes. The options are VT100, VT100+, **VT-UTF8**, and ANSI.

Bits Per second

This item sets the transmission speed for a serial port used in Console Redirection. Make sure that the same speed is used in both host computer and the client computer. A lower transmission speed may be required for long and busy lines. The options are 9600, 19200, 57600, and **115200** (bits per second).

Flow Control

Use this item to set the flow control for Console Redirection to prevent data loss caused by buffer overflow. Send a "Stop" signal to stop data-sending when the receiving buffer is full. Send a "Start" signal to start data-sending when the receiving buffer is empty. The options are **None**, Hardware RTS/CTS, and Software Xon/Xoff.

The settings below are displayed:

Data Bits, Parity, Stop Bits

► ACPI Settings

NUMA (Available when the OS supports this feature)

Select Enabled to enable Non-Uniform Memory Access support to enhance system performance. The options are Disabled and **Enabled**.

WHEA Support

Select Enabled to support the Windows Hardware Error Architecture (WHEA) platform and provide a common infrastructure for the system to handle hardware errors within the Windows OS environment to reduce system crashes and to enhance system recovery and health monitoring. The options are Disabled and **Enabled**.

High Precision Event Timer

Select Enabled to activate the High Precision Event Timer (HPET) that produces periodic interrupts at a much higher frequency than a Real-time Clock (RTC) does in synchronizing multimedia streams, providing smooth playback and reducing the dependency on other timestamp calculation devices, such as an x86 RDTSC Instruction embedded in the CPU. The High Performance Event Timer is used to replace the 8254 Programmable Interval Timer. The options are Disabled and **Enabled**.

ACPI Sleep State

This feature selects the ACPI Sleep State that the system will enter into when the suspend button is activated. The options are Suspend Disabled and **S3 (Suspend to RAM)**.

► Trusted Computing (Available when a TPM device is installed and detected by the BIOS)

Security Device Support

If a Trusted Platform Module (TPM) device is connected to the TPM header (JTPM1) on the motherboard and this feature is set to Enable, onboard security devices will be available for the TPM support to enhance data integrity and network security. Please reboot the system for a change on this setting to take effect. The options are Disable and **Enable**.

****If the item above is set to Enable, the following items will become available for user's configuration:***

The following Platform Configuration Register information will be displayed:

- **Active PCR banks**
- **Available PCR banks**

SHA256 PCR Bank

Use this item to disable or enable the SHA256 Platform Configuration Register (PCR) bank for the installed TPM device. The options are Disabled and **Enabled**.

Pending operation

Use this item to schedule a TPM-related operation to be performed by a security device for system data integrity. Your system will reboot to carry out a pending TPM operation. The options are **None** and TPM Clear.

Platform Hierarchy

Use this item to disable or enable platform hierarchy for platform protection. The options are Disabled and **Enabled**.

Storage Hierarchy

Use this item to disable or enable storage hierarchy for cryptographic protection. The options are Disabled and **Enabled**.

Endorsement Hierarchy

Use this item to disable or enable endorsement hierarchy for privacy control. The options are Disabled and **Enabled**.

PH Randomization

Use this feature to disable or enable Platform Hierarchy Randomization. The options are **Disabled** and Enabled.

SMC BIOS -Based TPM Provision Support

Use this feature to enable TPM Provision Support. Enabling this feature will lock your TPM. Once locked, the NV indexes will not be able to be deleted. The options are **Disabled** and Enabled.

TXT Support

Intel® TXT (Trusted Execution Technology) helps protect against software-based attacks and ensures protection, confidentiality, and integrity of data stored or created on the system. Use this feature to enable or disable TXT Support. The options are **Disabled** and Enabled.

▶ iSCSI Configuration

iSCSI Initiator Name

This feature allows the user to enter the unique name of the iSCSI Initiator in IQN format. Once the name of the iSCSI Initiator is entered into the system, configure the proper settings for the following items.

▶ Add an Attempt

▶ Delete Attempts

▶ Change Attempt order

▶ Intel® Virtual RAID on CPU

This submenu displays the information of the Intel® VMD controllers as detected by the BIOS.

6.4 Event Logs

Use this feature to configure the Event Log settings.

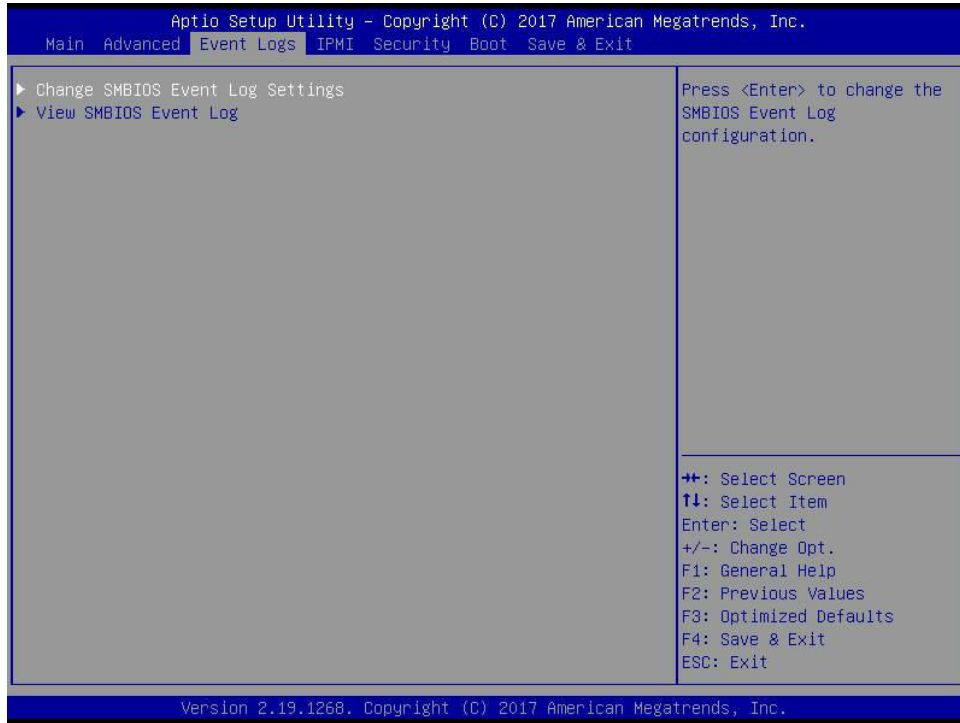

► Change SMBIOS Event Log Settings

Enabling/Disabling Options

SMBIOS Event Log

Change this item to enable or disable all features of the SMBIOS (System Management BIOS) Event Logging during system boot. The options are Disabled and **Enabled**.

Erasing Settings

Erase Event Log

If No is selected, data stored in the event log will not be erased. Select Yes, Next Reset, data in the event log will be erased upon next system reboot. Select Yes, Every Reset, data in the event log will be erased upon every system reboot. The options are **No**, (Yes, Next reset), and (Yes, Every reset).

When Log is Full

Select Erase Immediately for all messages to be automatically erased from the event log when the event log memory is full. The options are **Do Nothing** and Erase Immediately.

SMBIOS Event Log Standard Settings

Log System Boot Event

This option toggles the System Boot Event logging to enabled or disabled. The options are Enabled and **Disabled**.

MECI

The Multiple Event Count Increment (MECI) counter counts the number of occurrences that a duplicate event must happen before the MECI counter is incremented. This is a numeric value. The default value is **1**.

METW

The Multiple Event Time Window (METW) defines number of minutes must pass between duplicate log events before MECI is incremented. This is in minutes, from 0 to 99. The default value is **60**.

Note: After making changes on a setting, be sure to reboot the system for the changes to take effect.

►View SMBIOS Event Log

This section displays the contents of the SMBIOS Event Log.

6.5 IPMI

Use this feature to configure Intelligent Platform Management Interface (IPMI) settings.



BMC Firmware Revision

This item indicates the IPMI firmware revision used in your system.

IPMI STATUS (Baseboard Management Controller)

This item indicates the status of the IPMI firmware installed in your system.

► System Event Log

Enabling/Disabling Options

SEL Components

Select Enabled for all system event logging at bootup. The options are Disabled and **Enabled**.

Erasing Settings

Erase SEL

Select Yes, On next reset to erase all system event logs upon next system reboot. Select Yes, On every reset to erase all system event logs upon each system reboot. Select No to keep all system event logs after each system reboot. The options are **No**, (Yes, On next reset), and (Yes, On every reset).

When SEL is Full

This feature allows the user to decide what the BIOS should do when the system event log is full. Select Erase Immediately to erase all events in the log when the system event log is full. The options are **Do Nothing** and Erase Immediately.

Note: After making changes on a setting, be sure to reboot the system for the changes to take effect.

►BMC Network Configuration

BMC Network Configuration

Configure IPV4 support

IPMI LAN Selection

This item displays the IPMI LAN setting. The default setting is **Failover**.

IPMI Network Link Status

This item displays the IPMI Network Link status. The default setting is **Dedicated LAN**.

Update IPMI LAN Configuration

Select Yes for the BIOS to implement all IP/MAC address changes at the next system boot. The options are **No** and Yes.

****If the item above is set to Yes, the following items will become available for user's configuration:***

Configuration Address Source

This feature allows the user to select the source of the IP address for this computer. If Static is selected, you will need to know the IP address of this computer and enter it to the system manually in the field. If DHCP is selected, the BIOS will search for a DHCP (Dynamic Host Configuration Protocol) server in the network that is attached to and request the next available IP address for this computer. The options are Static and **DHCP**.

This item displays the current configuration address for this computer.

Station IP Address

This item displays the Station IP address for this computer. This should be in decimal and in dotted quad form (i.e., 192.168.10.253).

Subnet Mask

This item displays the sub-network that this computer belongs to. The value of each three-digit number separated by dots should not exceed 255.

Station MAC Address

This item displays the Station MAC address for this computer. Mac addresses are 6 two-digit hexadecimal numbers.

Gateway IP Address

This item displays the Gateway IP address for this computer. This should be in decimal and in dotted quad form (i.e., 172.31.0.1).

VLAN

Use this item to enable or disable the IPMI VLAN function. The options are **Disable** and **Enable**.

****If the item above is set to Enable, the following item, "VLAN ID", will become available for user's configuration:***

VLAN ID

Use this item to enter the VLAN ID. The default setting is **0**.

Configure IPV6 support

Lan channel 1

IPV6 Support

This item displays the IPMI LAN setting. The default setting is **Enabled**.

****If the item above is set to Enabled, the following items will become available for user's configuration:***

Configuration Address Source

This feature allows the user to select the source of the IP address for this computer. If Static is selected, you will need to know the IP address of this computer and enter it to the system manually in the field. If DHCP is selected, the BIOS will search for a DHCP (Dynamic Host Configuration Protocol) server in the network that is attached to and request the next available IP address for this computer. The options are **Unspecified**, **Static**, and **DHCP**.

The following information is displayed:

- Current Configuration Address source
- Station IPV6 address
- Prefix Length
- IPV6 Router1 IP Address
- IPV6 address status
- IPV6 DHCP Algorithm

6.6 Security

This menu allows the user to configure the following security settings for the system.

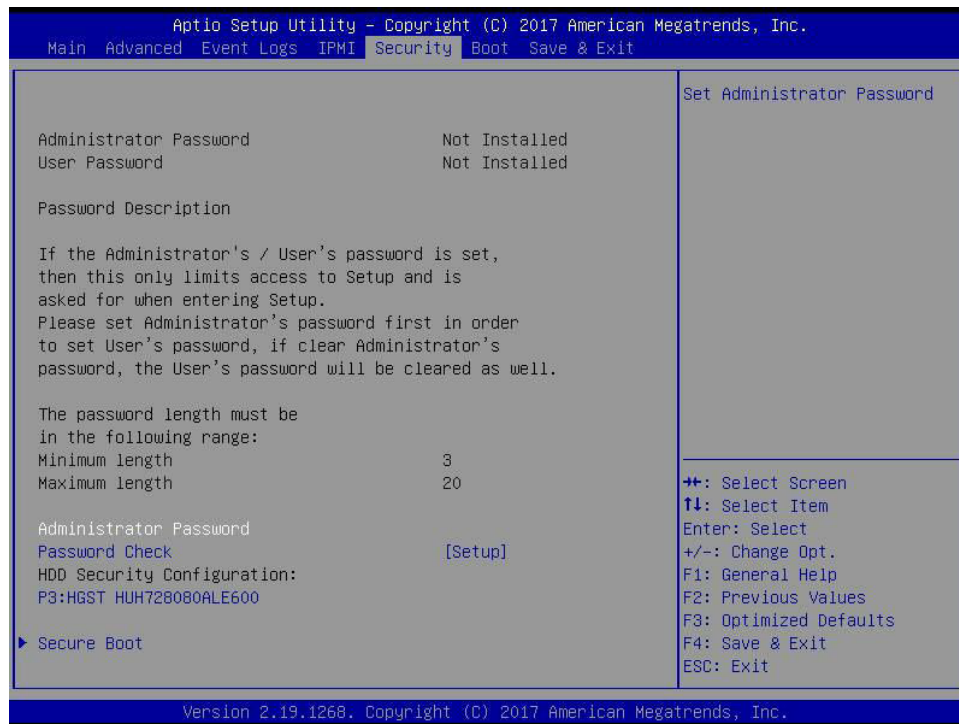

Administrator Password

Press Enter to set the user password which is required to enter the BIOS setup utility. The length of the password should be from 3 characters to 20 characters long.

User Password

Press Enter to set the user password which is required to enter the BIOS setup utility. The length of the password should be from 3 characters to 20 characters long.

Password Check

Select Setup for the system to check for a password at Setup. Select Always for the system to check for a password at bootup or upon entering the BIOS Setup utility. The options are **Setup** and **Always**.

HDD Security Configuration:

This item displays the HDD security configuration of the selected drive.

► Secure Boot

This section displays the contents of the following secure boot features:

- System Mode

- Secure Boot
- Vendor Keys

Secure Boot

Use this item to enable secure boot. The options are **Disabled** and Enabled.

Secure Boot Mode

Use this item to select the secure boot mode. The options are Standard and **Custom**.

CSM Support

Select Enabled to support the EFI Compatibility Support Module (CSM), which provides compatibility support for traditional legacy BIOS for system boot. The options are Disabled and **Enabled**.

► Key Management

This submenu allows the user to configure the following Key Management settings.

Provision Factory Defaults

Select Enabled to install the default Secure-Boot keys set by the manufacturer. The options are **Disabled** and Enabled.

► Enroll all Factory Default Keys

Select Yes to install all default secure keys set by the manufacturer. The options are **Yes** and No.

► Enroll Efi Image

This feature allows the image to run in Secure Boot Mode. Enroll SHA256 Hash Certificate of the image into the Authorized Signature Database.

► Save all Secure Boot variables

This feature allows the user to decide if all secure boot variables should be saved.

Secure Boot variable: Size/ Key#/ Key Source

► Platform Key (PK)

This feature allows the user to configure the settings of the platform keys.

Set New

Use this feature to load the new platform keys (PK) from the manufacturer's defaults.

▶ Key Exchange Keys (KEK)

Select Set New to load the KEK from the manufacturer's defaults. Select Append to add the KEK from the manufacturer's defaults list to the existing KEK. The default setting is **Set New**.

▶ Authorized Signatures

Authorized Signature Database (DB) contains authorized signing certificates and digital signatures. Select Set New to load the DB from the manufacturer's defaults. Select Append to add the database from the manufacturer's defaults to the existing DB. The default setting is **Set New**.

▶ Forbidden Signatures

Forbidden Signature Database (DBX) contains forbidden certificates and digital signatures. Select Set New to load the DBX from the manufacturer's defaults. Select Append to add the DBX from the manufacturer's defaults to the existing DBX. The default setting is **Set New**.

▶ Authorized TimeStamps

Select Set New to load the Authorized Timestamp Database (DBT) from the manufacturer's defaults. Select Append to add the DBT from the manufacturer's defaults list to the existing DBT. The default setting is **Set New**.

▶ OsRecovery Signatures

Select Set New to load the OsRecovery Signatures Database (DBR) from the manufacturer's defaults. Select Append to add the DBR from the manufacturer's defaults list to the existing DBR. The default setting is **Set New**.

6.7 Boot

Use this feature to configure Boot Settings:

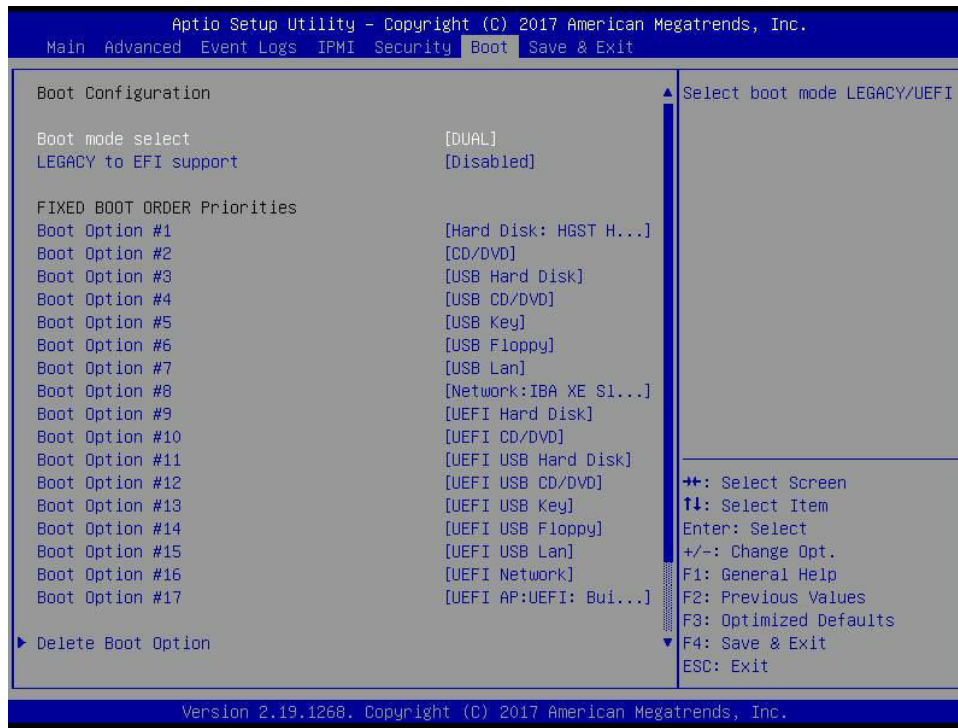

Boot mode select

Use this item to select the type of device that the system is going to boot from. The options are LEGACY, UEFI, and **DUAL**. The default setting is **DUAL**.

LEGACY to EFI support

Use this item to enable the EFI boot support. The options are **Disabled** and Enabled.

FIXED BOOT ORDER Priorities

This option prioritizes the order of bootable devices that the system to boot from. Press <Enter> on each entry from top to bottom to select devices.

****If the item above, "Boot mode select", is set to Legacy/UEFI/Dual, the following items will be displayed:***

- Legacy/UEFI/Dual Boot Order #1
- Legacy/UEFI/Dual Boot Order #2
- Legacy/UEFI/Dual Boot Order #3
- Legacy/UEFI/Dual Boot Order #4
- Legacy/UEFI/Dual Boot Order #5

- Legacy/UEFI/Dual Boot Order #6
- Legacy/UEFI/Dual Boot Order #7
- Legacy/UEFI/Dual Boot Order #8
- UEFI/Dual Boot Order #9
- Dual Boot Order #10
- Dual Boot Order #11
- Dual Boot Order #12
- Dual Boot Order #13
- Dual Boot Order #14
- Dual Boot Order #15
- Dual Boot Order #16
- Dual Boot Order #17

► Add New Boot Option

This feature allows the user to add a new boot option to the boot priority features for your system.

Add Boot Option

Use this item to specify the name for the new boot option.

Path for Boot Option

Use this item to enter the path for the new boot option in the format `fsx:\path\filename.efi`.

Boot Option File Path

Use this item to specify the file path for the new boot option.

Create

Use this item to set the name and the file path of the new boot option.

► Delete Boot Option

Use this feature to remove a pre-defined boot device from which the system will boot during startup. The options are **Select one to Delete** and UEFI: Built-in EFI Shell.

►UEFI Application Boot Priorities

This feature allows the user to specify which UEFI devices are boot devices.

Boot Option #1

The options are **UEFI: Built-in EFI Shell** and Disabled.

►Hard Disk Drive BBS Priorities

This feature allows the user to specify the boot device priority from the available hard disk drives.

Boot Option #1

The options are **(the available hard disk drive)** and Disabled.

►Network Drive BBS Priorities

This feature allows the user to specify which available network drives are boot devices.

Boot Option #1

The options are **IBA XE Slot 0100 v2398** and Disabled.

6.8 Save & Exit

Select the Save & Exit tab from the BIOS setup screen to configure the settings below.

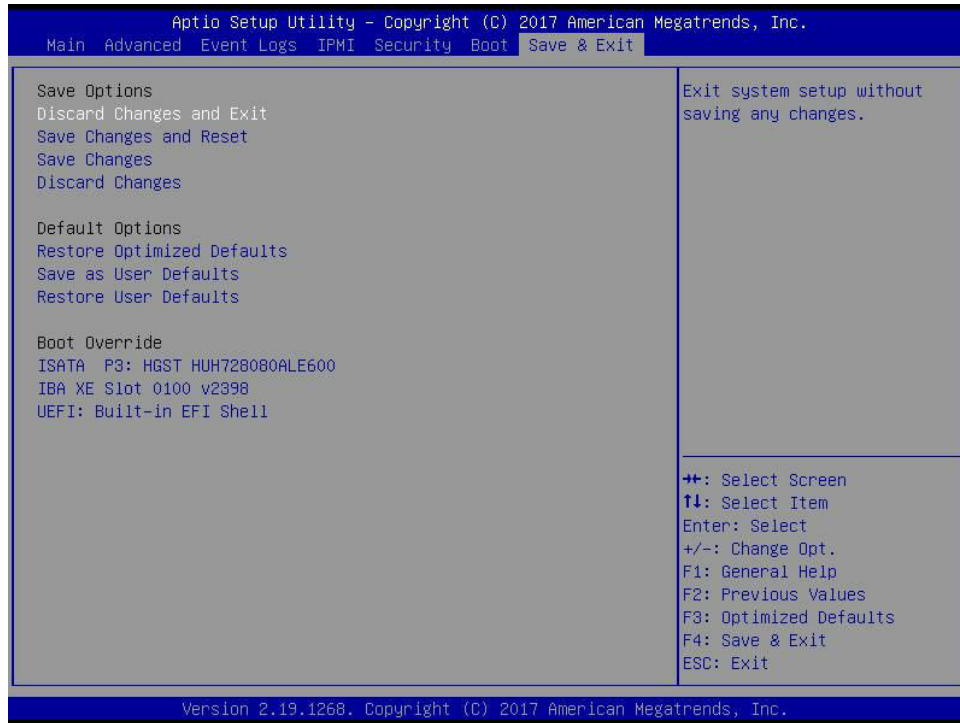

Save Options

Discard Changes and Exit

Select this option to quit the BIOS Setup without making any permanent changes to the system configuration, and reboot the computer. Select Discard Changes and Exit from the Exit menu and press <Enter>.

Save Changes and Reset

After completing the system configuration changes, select this option to save the changes you have made. This will reset (reboot) the system.

Save Changes

When you have completed the system configuration changes, select this option to save all changes made. This will not reset (reboot) the system.

Discard Changes

Select this option and press <Enter> to discard all the changes and return to the AMI BIOS utility Program.

Listed on this section are other boot options for the system (i.e., Built-in EFI shell). Select an option and press <Enter>. Your system will boot to the selected boot option.

Default Options

Restore Optimized Defaults

To set this feature, select Restore Optimized Defaults from the Save & Exit menu and press <Enter>. These are factory settings designed for maximum system stability, but not for maximum performance.

Save As User Defaults

To set this feature, select Save as User Defaults from the Exit menu and press <Enter>. This enables the user to save any changes to the BIOS setup for future use.

Restore User Defaults

To set this feature, select Restore User Defaults from the Exit menu and press <Enter>. Use this feature to retrieve user-defined settings that were saved previously.

Boot Override

Listed on this section are other boot options for the system (i.e., Built-in EFI shell). Select an option and press <Enter>. Your system will boot to the selected boot option.

Appendix A

BIOS Error Codes

A.1 BIOS Error Beep (POST) Codes

During the POST (Power-On Self-Test) routines, which are performed each time the system is powered on, errors may occur.

Non-fatal errors are those which, in most cases, allow the system to continue the boot-up process. The error messages normally appear on the screen.

Fatal errors are those which will not allow the system to continue the boot-up procedure. If a fatal error occurs, you should consult with your system manufacturer for possible repairs.

These fatal errors are usually communicated through a series of audible beeps. The table below lists some common errors and their corresponding beep codes encountered by users.

X11 Serverboard BIOS Error Beep Codes		
Beep Code/LED	Error Message	Description
1 beep	Refresh	Ready to boot
5 short beeps + 1 long beep	Memory error	No memory detected in the system
5 beeps	No Con-In or No Con-Out devices	Con-In includes USB or PS/2 keyboard, PCI or Serial Console Redirection, IPMI KVM or SOL. Con-Out includes Video Controller, PCI or Serial Console Redirection, IPMI SOL.
1 beep per device	Refresh	1 beep for each USB device detected
X11 IPMI Error Codes		
1 Continuous Beep	System OH	System Overheat

A.2 Additional BIOS POST Codes

The AMI BIOS supplies additional checkpoint codes, which are documented online at <http://www.supermicro.com/support/manuals/> ("AMI BIOS POST Codes User's Guide").

When BIOS performs the Power On Self Test, it writes checkpoint codes to I/O port 0080h. If the computer cannot complete the boot process, a diagnostic card can be attached to the computer to read I/O port 0080h (Supermicro p/n AOC-LPC80-20).

For information on AMI updates, please refer to <http://www.ami.com/products/>.

Appendix B

Standardized Warning Statements for AC Systems

B.1 About Standardized Warning Statements

The following statements are industry standard warnings, provided to warn the user of situations which have the potential for bodily injury. Should you have questions or experience difficulty, contact Supermicro's Technical Support department for assistance. Only certified technicians should attempt to install or configure components.

Read this appendix in its entirety before installing or configuring components in the Supermicro chassis.

These warnings may also be found on our website at http://www.supermicro.com/about/policies/safety_information.cfm.

Warning Definition



Warning! This warning symbol means danger. You are in a situation that could cause bodily injury. Before you work on any equipment, be aware of the hazards involved with electrical circuitry and be familiar with standard practices for preventing accidents.

警告の定義

この警告サインは危険を意味します。

人身事故につながる可能性がありますので、いずれの機器でも動作させる前に、電気回路に含まれる危険性に注意して、標準的な事故防止策に精通して下さい。

此警告符号代表危險。

您正处于可能受到严重伤害的工作环境中。在您使用设备开始工作之前，必须充分意识到触电的危险，并熟练掌握防止事故发生的标准工作程序。请根据每项警告结尾的声明号码找到此设备的安全性警告说明的翻译文本。

此警告符號代表危險。

您正處於可能身體可能會受損傷的工作環境中。在您使用任何設備之前，請注意觸電的危險，並且要熟悉預防事故發生的標準工作程序。請依照每一注意事項後的號碼找到相關的翻譯說明內容。

Warnung

WICHTIGE SICHERHEITSHINWEISE

Dieses Warnsymbol bedeutet Gefahr. Sie befinden sich in einer Situation, die zu Verletzungen führen kann. Machen Sie sich vor der Arbeit mit Geräten mit den Gefahren elektrischer Schaltungen und den üblichen Verfahren zur Vorbeugung vor Unfällen vertraut. Suchen Sie mit der am Ende jeder Warnung angegebenen Anweisungsnummer nach der jeweiligen Übersetzung in den übersetzten Sicherheitshinweisen, die zusammen mit diesem Gerät ausgeliefert wurden.

BEWAHREN SIE DIESE HINWEISE GUT AUF.

INSTRUCCIONES IMPORTANTES DE SEGURIDAD

Este símbolo de aviso indica peligro. Existe riesgo para su integridad física. Antes de manipular cualquier equipo, considere los riesgos de la corriente eléctrica y familiarícese con los procedimientos estándar de prevención de accidentes. Al final de cada advertencia encontrará el número que le ayudará a encontrar el texto traducido en el apartado de traducciones que acompaña a este dispositivo.

GUARDE ESTAS INSTRUCCIONES.

IMPORTANTES INFORMATIONS DE SÉCURITÉ

Ce symbole d'avertissement indique un danger. Vous vous trouvez dans une situation pouvant entraîner des blessures ou des dommages corporels. Avant de travailler sur un équipement, soyez conscient des dangers liés aux circuits électriques et familiarisez-vous avec les procédures couramment utilisées pour éviter les accidents. Pour prendre connaissance des traductions des avertissements figurant dans les consignes de sécurité traduites qui accompagnent cet appareil, référez-vous au numéro de l'instruction situé à la fin de chaque avertissement.

CONSERVEZ CES INFORMATIONS.

תקנון הזהרות אזהרה

הזהרות הבאות הן אזהרות על פי תקני התעשייה, על מנת להזהיר את המשתמש מפני חבלה פיזית אפשרית. במידה ויש שאלות או היתקלות בבעיה כלשהי, יש ליצור קשר עם מחלקת תמיכה טכנית של סופרמיקרו. טכנאים מוסמכים בלבד רשאים להתקין או להגדיר את הרכיבים. יש לקרוא את הנספח במלואו לפני התקנת או הגדרת הרכיבים במארזי סופרמיקרו.

اَكْ ف حالة وُكِي اَي تتسبب ف اصابة جسدهُ هذا الزهز عُ خطر! تحذُرُ .
قبل اَي تعول على اَي هعدات، كي على علن بالوخاطز ال اُجوة عي الذوائر
الكهزبائِة
وكي على دراةُ بالووارسات النقاائِة لو عُ وقع اَي حادث
استخدم رِقن الب اِي الو صُص ف هَاةُ كل تحذُرُ للعشر تزجوتها

안전을 위한 주의사항

경고!

이 경고 기호는 위험이 있음을 알려 줍니다. 작업자의 신체에 부상을 야기 할 수 있는 상태에 있게 됩니다. 모든 장비에 대한 작업을 수행하기 전에 전기회로와 관련된 위험요소들을 확인하시고 사전에 사고를 방지할 수 있도록 표준 작업절차를 준수해 주시기 바랍니다.

해당 번역문을 찾기 위해 각 경고의 마지막 부분에 제공된 경고문 번호를 참조하십시오

BELANGRIJKE VEILIGHEIDSINSTRUCTIES

Dit waarschuwings symbool betekent gevaar. U verkeert in een situatie die lichamelijk letsel kan veroorzaken. Voordat u aan enige apparatuur gaat werken, dient u zich bewust te zijn van de bij een elektrische installatie betrokken risico's en dient u op de hoogte te zijn van de standaard procedures om ongelukken te voorkomen. Gebruik de nummers aan het eind van elke waarschuwing om deze te herleiden naar de desbetreffende locatie.

BEWAAR DEZE INSTRUCTIES

Installation Instructions



Warning! Read the installation instructions before connecting the system to the power source.

設置手順書

システムを電源に接続する前に、設置手順書をお読み下さい。

警告

将此系统连接电源前，请先阅读安装说明。

警告

將系統與電源連接前，請先閱讀安裝說明。

Warnung

Vor dem Anschließen des Systems an die Stromquelle die Installationsanweisungen lesen.

¡Advertencia!

Lea las instrucciones de instalación antes de conectar el sistema a la red de alimentación.

Attention

Avant de brancher le système sur la source d'alimentation, consulter les directives d'installation.

יש לקרוא את הוראות התקנה לפני חיבור המערכת למקור מתח.

اقرأ إرشادات التركيب قبل توصيل النظام إلى مصدر للطاقة

시스템을 전원에 연결하기 전에 설치 안내를 읽어주십시오.

Waarschuwing

Raadpleeg de installatie-instructies voordat u het systeem op de voedingsbron aansluit.

Circuit Breaker

Warning! This product relies on the building's installation for short-circuit (overcurrent) protection. Ensure that the protective device is rated not greater than: 250 V, 20 A.

サーキット・ブレーカー

この製品は、短絡(過電流)保護装置がある建物での設置を前提としています。

保護装置の定格が250 V、20 Aを超えないことを確認下さい。

警告

此产品的短路(过载电流)保护由建筑物的供电系统提供,确保短路保护设备的额定电流不大于250V,20A。

警告

此產品的短路(過載電流)保護由建築物的供電系統提供,確保短路保護設備的額定電流不大於250V,20A。

Warnung

Dieses Produkt ist darauf angewiesen, dass im Gebäude ein Kurzschluss- bzw. Überstromschutz installiert ist. Stellen Sie sicher, dass der Nennwert der Schutzvorrichtung nicht mehr als: 250 V, 20 A beträgt.

¡Advertencia!

Este equipo utiliza el sistema de protección contra cortocircuitos (o sobrecorrientes) del edificio. Asegúrese de que el dispositivo de protección no sea superior a: 250 V, 20 A.

Attention

Pour ce qui est de la protection contre les courts-circuits (surtension), ce produit dépend de l'installation électrique du local. Vérifiez que le courant nominal du dispositif de protection n'est pas supérieur à :250 V, 20 A.

מוצר זה מסתמך על הגנה המותקנת במבנים למניעת קצר חשמלי. יש לוודא כי המכשיר המגן מפני הקצר החשמלי הוא לא יותר מ-250VDC, 20A

هذا المنتج يعتمد على معدات الحماية من الدوائر القصيرة التي تم تثبيتها في المبنى
تأكد من أن تقييم الجهاز الوقائي ليس أكثر من : 20A, 250V

경고!

이 제품은 전원의 단락(과전류)방지에 대해서 전적으로 건물의 관련 설비에 의존합니다. 보호장치의 정격이 반드시 250V(볼트), 20A(암페어)를 초과하지 않도록 해야 합니다.

Waarschuwing

Dit product is afhankelijk van de kortsluitbeveiliging (overspanning) van uw elektrische installatie. Controleer of het beveiligde apparaat niet groter gedimensioneerd is dan 250V, 20A.

Power Disconnection Warning



Warning! The system must be disconnected from all sources of power and the power cord removed from the power supply module(s) before accessing the chassis interior to install or remove system components.

電源切断の警告

システムコンポーネントの取り付けまたは取り外しのために、シャーシ内部にアクセスするには、システムの電源はすべてのソースから切断され、電源コードは電源モジュールから取り外す必要があります。

警告

在你打开机箱并安装或移除内部器件前,必须将系统完全断电,并移除电源线。

警告

在您打開機殼安裝或移除內部元件前，必須將系統完全斷電，並移除電源線。

Warnung

Das System muss von allen Quellen der Energie und vom Netzanschlusskabel getrennt sein, das von den Spg.Versorgungsteilmodulen entfernt wird, bevor es auf den Chassisinnenraum zurückgreift, um Systemsbestandteile anzubringen oder zu entfernen.

¡Advertencia!

El sistema debe ser disconnected de todas las fuentes de energía y del cable eléctrico quitado de los módulos de fuente de alimentación antes de tener acceso el interior del chasis para instalar o para quitar componentes de sistema.

Attention

Le système doit être débranché de toutes les sources de puissance ainsi que de son cordon d'alimentation secteur avant d'accéder à l'intérieur du chassis pour installer ou enlever des composants de système.

אזהרה מפני ניתוק חשמלי

אזהרה!

יש לנתק את המערכת מכל מקורות החשמל ויש להסיר את כבל החשמלי מהספק לפני גישה לחלק הפנימי של המארז לצורך התקנת או הסרת רכיבים.

يجب فصل انظاؤ من جميع مصادر انطاقت وإزانت سهك انكهرباء من وحدة امداد
انطاقت قېم
انصل إلى امناطق انداخهيت نههيكم نتشيج أو إزانت مكناث الجهاز

경고!

시스템에 부품들을 장착하거나 제거하기 위해서는 새시 내부에 접근하기 전에 반드시 전원 공급장치로부터 연결되어있는 모든 전원과 전기코드를 분리해주어야 합니다.

Waarschuwing

Voordat u toegang neemt tot het binnenwerk van de behuizing voor het installeren of verwijderen van systeem onderdelen, dient u alle spanningsbronnen en alle stroomkabels aangesloten op de voeding(en) van de behuizing te verwijderen

Equipment Installation



Warning! Only trained and qualified personnel should be allowed to install, replace, or service this equipment.

機器の設置

トレーニングを受け認定された人だけがこの装置の設置、交換、またはサービスを許可されていません。

警告

只有经过培训且具有资格的人员才能进行此设备的安装、更换和维修。

警告

只有經過受訓且具資格人員才可安裝、更換與維修此設備。

Warnung

Das Installieren, Ersetzen oder Bedienen dieser Ausrüstung sollte nur geschultem, qualifiziertem Personal gestattet werden.

¡Advertencia!

Solamente el personal calificado debe instalar, reemplazar o utilizar este equipo.

Attention

Il est vivement recommandé de confier l'installation, le remplacement et la maintenance de ces équipements à des personnels qualifiés et expérimentés.

אזהרה!

צוות מוסמך בלבד רשאי להתקין, להחליף את הציוד או לתת שירות עבור הציוד.

والمدربيه لتزكيب واستبدال أو خدمة هذا الجهاز يجب أن يسمح فقط للمظفيه المؤهليه

경고!

훈련을 받고 공인된 기술자만이 이 장비의 설치, 교체 또는 서비스를 수행할 수 있습니다.

Waarschuwing

Deze apparatuur mag alleen worden geïnstalleerd, vervangen of hersteld door geschoold en gekwalificeerd personeel.

Restricted Area



Warning! This unit is intended for installation in restricted access areas. A restricted access area can be accessed only through the use of a special tool, lock and key, or other means of security. (This warning does not apply to workstations).

アクセス制限区域

このユニットは、アクセス制限区域に設置されることを想定しています。

アクセス制限区域は、特別なツール、鍵と錠前、その他のセキュリティの手段を用いてのみ出入りが可能です。

警告

此部件应安装在限制进出的场所，限制进出的场所指只能通过使用特殊工具、锁和钥匙或其它安全手段进出的场所。

警告

此装置僅限安裝於進出管制區域，進出管制區域係指僅能以特殊工具、鎖頭及鑰匙或其他安全方式才能進入的區域。

Warnung

Diese Einheit ist zur Installation in Bereichen mit beschränktem Zutritt vorgesehen. Der Zutritt zu derartigen Bereichen ist nur mit einem Spezialwerkzeug, Schloss und Schlüssel oder einer sonstigen Sicherheitsvorkehrung möglich.

¡Advertencia!

Esta unidad ha sido diseñada para instalación en áreas de acceso restringido. Sólo puede obtenerse acceso a una de estas áreas mediante la utilización de una herramienta especial, cerradura con llave u otro medio de seguridad.

Attention

Cet appareil doit être installée dans des zones d'accès réservés. L'accès à une zone d'accès réservé n'est possible qu'en utilisant un outil spécial, un mécanisme de verrouillage et une clé, ou tout autre moyen de sécurité.

אזור עם גישה מוגבלת

אזהרה!

יש להתקין את היחידה באזורים שיש בהם הגבלת גישה. הגישה ניתנת בעזרת 'כלי אבטחה בלבד' (מפתח, מנעול וכד.).

تخصيص هذه انحدة نترك بُها ف مناطق محظورة تم .
ممكن اننصل إن منطقت محظورة فقط من خلال استخذاو أداة خاصت
أو أ وس هُت أخري نلالأمما ققم ومفتاح

경고!

이 장치는 접근이 제한된 구역에 설치하도록 되어있습니다. 특수도구, 잠금 장치 및 키, 또는 기타 보안 수단을 통해서만 접근 제한 구역에 들어갈 수 있습니다.

Waarschuwing

Dit apparaat is bedoeld voor installatie in gebieden met een beperkte toegang. Toegang tot dergelijke gebieden kunnen alleen verkregen worden door gebruik te maken van speciaal gereedschap, slot en sleutel of andere veiligheidsmaatregelen.

Battery Handling



Warning! There is the danger of explosion if the battery is replaced incorrectly. Replace the battery only with the same or equivalent type recommended by the manufacturer. Dispose of used batteries according to the manufacturer's instructions

電池の取り扱い

電池交換が正しく行われなかった場合、破裂の危険性があります。交換する電池はメーカーが推奨する型、または同等のものを使用下さい。使用済電池は製造元の指示に従って処分して下さい。

警告

電池更換不當會有爆炸危險。請只使用同類電池或制造商推薦的功能相當的電池更換原有電池。請按製造商的說明處理廢舊電池。

警告

電池更換不當會有爆炸危險。請使用製造商建議之相同或功能相當的電池更換原有電池。請按照製造商的說明指示處理廢棄舊電池。

Warnung

Bei Einsetzen einer falschen Batterie besteht Explosionsgefahr. Ersetzen Sie die Batterie nur durch den gleichen oder vom Hersteller empfohlenen Batterietyp. Entsorgen Sie die benutzten Batterien nach den Anweisungen des Herstellers.

Attention

Danger d'explosion si la pile n'est pas remplacée correctement. Ne la remplacer que par une pile de type semblable ou équivalent, recommandée par le fabricant. Jeter les piles usagées conformément aux instructions du fabricant.

¡Advertencia!

Existe peligro de explosión si la batería se reemplaza de manera incorrecta. Reemplazar la batería exclusivamente con el mismo tipo o el equivalente recomendado por el fabricante. Desechar las baterías gastadas según las instrucciones del fabricante.

אזהרה!

קיימת סכנת פיצוץ של הסוללה במידה והוחלפה בדרך לא תקינה. יש להחליף את הסוללה בסוג התואם מחברת יצרן מומלצת. סילוק הסוללות המשומשות יש לבצע לפי הוראות היצרן.

هناك خطر من انفجار في حالة اسبدال البطارية بطريقة غير صحيحة فعلياً
اسبدال البطارية
فقط بنفس النوع أو ما يعادلها مما أوصت به الشركة المصنعة
جخلص من البطاريات المسحومة وفقاً لعمليات الشركة الصانعة

경고!

배터리가 올바르게 교체되지 않으면 폭발의 위험이 있습니다. 기존 배터리와 동일하거나 제조사에서 권장하는 동등한 종류의 배터리로만 교체해야 합니다. 제조사의 안내에 따라 사용된 배터리를 처리하여 주십시오.

Waarschuwing

Er is ontplofingsgevaar indien de batterij verkeerd vervangen wordt. Vervang de batterij slechts met hetzelfde of een equivalent type die door de fabrikant aanbevolen wordt. Gebruikte batterijen dienen overeenkomstig fabrieksvoorschriften afgevoerd te worden.

Redundant Power Supplies



Warning! This unit might have more than one power supply connection. All connections must be removed to de-energize the unit.

冗長電源装置

このユニットは複数の電源装置が接続されている場合があります。

ユニットの電源を切るためには、すべての接続を取り外さなければなりません。

警告

此部件连接的电源可能不止一个，必须将所有电源断开才能停止给该部件供电。

警告

此装置连接的电源可能不只一个，必须切断所有电源才能停止对该装置的供电。

Warnung

Dieses Gerät kann mehr als eine Stromzufuhr haben. Um sicherzustellen, dass der Einheit kein Strom zugeführt wird, müssen alle Verbindungen entfernt werden.

¡Advertencia!

Puede que esta unidad tenga más de una conexión para fuentes de alimentación. Para cortar por completo el suministro de energía, deben desconectarse todas las conexiones.

Attention

Cette unité peut avoir plus d'une connexion d'alimentation. Pour supprimer toute tension et tout courant électrique de l'unité, toutes les connexions d'alimentation doivent être débranchées.

אם קיים יותר מספק אחד

אזהרה!

ליחידה יש יותר מחיבור אחד של ספק. יש להסיר את כל החיבורים על מנת לרוקן את היחידה.

قد يكون لهذا الجهاز عدة اتصالات بوحدات امداد الطاقة .

يجب إزالة كافة الاتصالات لعسل الوحدة عن الكهرباء

경고!

이 장치에는 한 개 이상의 전원 공급 단자가 연결되어 있을 수 있습니다. 이 장치에 전원을 차단하기 위해서는 모든 연결 단자를 제거해야만 합니다.

Waarschuwing

Deze eenheid kan meer dan één stroomtoevoeraansluiting bevatten. Alle aansluitingen dienen verwijderd te worden om het apparaat stroomloos te maken.

Backplane Voltage



Warning! Hazardous voltage or energy is present on the backplane when the system is operating. Use caution when servicing.

バックプレーンの電圧

システムの稼働中は危険な電圧または電力が、バックプレーン上にかかっています。

修理する際には注意ください。

警告

当系统正在进行时，背板上有很危险的电压或能量，进行维修时务必小心。

警告

當系統正在進行時，背板上有很危險的電壓或能量，進行維修時務必小心。

Warnung

Wenn das System in Betrieb ist, treten auf der Rückwandplatine gefährliche Spannungen oder Energien auf. Vorsicht bei der Wartung.

¡Advertencia!

Cuando el sistema está en funcionamiento, el voltaje del plano trasero es peligroso. Tenga cuidado cuando lo revise.

Attention

Lorsque le système est en fonctionnement, des tensions électriques circulent sur le fond de panier. Prendre des précautions lors de la maintenance.

מתח בפנל האחורי

אזהרה!

קיימת סכנת מתח בפנל האחורי בזמן תפעול המערכת. יש להיזהר במהלך העבודה.

هناك خطر من التيار الكهربائي أو الطاقة المتجددة على اللوحة
عندما يكون النظام يعمل كه حذرا عند خدمة هذا الجهاز

경고!

시스템이 동작 중일 때 후면판 (Backplane)에는 위험한 전압이나 에너지가 발생 합니다.
서비스 작업 시 주의하십시오.

Waarschuwing

Een gevaarlijke spanning of energie is aanwezig op de backplane wanneer het systeem in gebruik is. Voorzichtigheid is geboden tijdens het onderhoud.

Comply with Local and National Electrical Codes



Warning! Installation of the equipment must comply with local and national electrical codes.

地方および国の電気規格に準拠

機器の取り付けはその地方および国の電気規格に準拠する必要があります。

警告

设备安装必须符合本地与本国电气法规。

警告

設備安裝必須符合本地與本國電氣法規。

Warnung

Die Installation der Geräte muss den Sicherheitsstandards entsprechen.

¡Advertencia!

La instalación del equipo debe cumplir con las normas de electricidad locales y nacionales.

Attention

L'équipement doit être installé conformément aux normes électriques nationales et locales.

תיאום חוקי החשמל הארצי

אזהרה!

התקנת הציוד חייבת להיות תואמת לחוקי החשמל המקומיים והארציים.

تركيب المعدات الكهربائية يجب أن يمتثل للقوايه المحلية والبطية المتعلقة
بالكهرباء

경고!

현 지역 및 국가의 전기 규정에 따라 장비를 설치해야 합니다.

Waarschuwing

Bij installatie van de apparatuur moet worden voldaan aan de lokale en nationale elektriciteitsvoorschriften.

Product Disposal



Warning! Ultimate disposal of this product should be handled according to all national laws and regulations.

製品の廃棄

この製品を廃棄処分する場合、国の関係する全ての法律・条例に従い処理する必要があります。

警告

本产品的废弃处理应根据所有国家的法律和规章进行。

警告

本產品的廢棄處理應根據所有國家的法律和規章進行。

Warnung

Die Entsorgung dieses Produkts sollte gemäß allen Bestimmungen und Gesetzen des Landes erfolgen.

¡Advertencia!

Al deshacerse por completo de este producto debe seguir todas las leyes y reglamentos nacionales.

Attention

La mise au rebut ou le recyclage de ce produit sont généralement soumis à des lois et/ou directives de respect de l'environnement. Renseignez-vous auprès de l'organisme compétent.

סילוק המוצר

אזהרה!

סילוק סופי של מוצר זה חייב להיות בהתאם להנחיות וחוקי המדינה.

التخلص النهائي من هذا المنتج ينبغي التعامل معه وفقا لجميع القوانين واللوائح الوطنية عند

경고!

이 제품은 해당 국가의 관련 법규 및 규정에 따라 폐기되어야 합니다.

Waarschuwing

De uiteindelijke verwijdering van dit product dient te geschieden in overeenstemming met alle nationale wetten en reglementen.

Hot Swap Fan Warning



Warning! Hazardous moving parts. Keep away from moving fan blades. The fans might still be turning when you remove the fan assembly from the chassis. Keep fingers, screwdrivers, and other objects away from the openings in the fan assembly's housing.

ファン・ホットスワップの警告

警告!回転部品に注意。運転中は回転部(羽根)に触れないでください。シャーシから冷却ファン装置を取り外した際、ファンがまだ回転している可能性があります。ファンの開口部に、指、ドライバー、およびその他のものを近づけないで下さい。

警告!

警告! 危险的可移动性零件。请务必与转动的风扇叶片保持距离。当您从机架移除风扇装置, 风扇可能仍在转动。小心不要将手指、螺丝起子和其他物品太靠近风扇

警告

危险的可移动性零件。请务必与转动的风扇叶片保持距离。当您从机架移除风扇装置, 风扇可能仍在转动。小心不要将手指、螺丝起子和其他物品太靠近风扇。

Warnung

Gefährlich Bewegende Teile. Von den bewegenden Lüfterblätter fern halten. Die Lüfter drehen sich u. U. noch, wenn die Lüfterbaugruppe aus dem Chassis genommen wird. Halten Sie Finger, Schraubendreher und andere Gegenstände von den Öffnungen des Lüftergehäuses entfernt.

¡Advertencia!

Riesgo de piezas móviles. Mantener alejado de las aspas del ventilador. Los ventiladores podran dar vuelta cuando usted quite el montaje del ventilador del chasis. Mantenga los dedos, los destornilladores y todos los objetos lejos de las aberturas del ventilador

Attention

Pieces mobiles dangereuses. Se tenir a l'écart des lames du ventilateur Il est possible que les ventilateurs soient toujours en rotation lorsque vous retirerez le bloc ventilateur du châssis. Prenez garde à ce que doigts, tournevis et autres objets soient éloignés du logement du bloc ventilateur.

אזהרה!

חלקים נעים מסוכנים. התרחק מלהבי המאוורר בפעולה כאשר מסירים את חלקי המאוורר מהמארז, יתכן והמאווררים עדיין עובדים. יש להרחיק למרחק בטוח את האצבעות וכלי עבודה שונים מהפתחים בתוך המאוורר

تحذير! أجزاء متحركة خطيرة. ابتعد عن شفرات المروحة المتحركة. من الممكن أن المراوح لا تزال تدور عند إزالة كتلة المروحة من الهيكل يجب إبقاء الأصابع ومفكات البراغي وغيرها من الأشياء بعيدا عن الفتحات في كتلة المروحة

경고!

움직이는 위험한 부품. 회전하는 송풍 날개에 접근하지 마세요. 새시로부터 팬 조립품을 제거할 때 팬은 여전히 회전하고 있을 수 있습니다. 팬 조립품 외관의 열려있는 부분들로부터 손가락 및 스크류드라이버, 다른 물체들이 가까이 하지 않도록 배치해 주십시오.

Waarschuwing

Gevaarlijk bewegende onderdelen. Houd voldoende afstand tot de bewegende ventilatorbladen. Het is mogelijk dat de ventilator nog draait tijdens het verwijderen van het ventilatorsamenstel uit het chassis. Houd uw vingers, schroevendraaiers en eventuele andere voorwerpen uit de buurt van de openingen in de ventilatorbehuizing.

Power Cable and AC Adapter



Warning! When installing the product, use the provided or designated connection cables, power cables and AC adaptors. Using any other cables and adaptors could cause a malfunction or a fire. Electrical Appliance and Material Safety Law prohibits the use of UL or CSA -certified cables (that have UL/CSA shown on the code) for any other electrical devices than products designated by Supermicro only.

電源コードとACアダプター

製品を設置する場合、提供または指定および購入された接続ケーブル、電源コードとACアダプターを該当する地域の条例や安全基準に適合するコードサイズやプラグと共に使用下さい。他のケーブルやアダプタを使用すると故障や火災の原因になることがあります。

電気用品安全法は、ULまたはCSA認定のケーブル(UL/CSAマークがコードに表記)を Supermicro が指定する製品以外に使用することを禁止しています。

警告

安装此产品时,请使用本身提供的或指定的或采购的连接线,电源线和电源适配器, 包含遵照当地法规和安全要求的合规的电源线尺寸和插头.使用其它线材或适配器可能会引起故障或火灾。除了Supermicro所指定的产品,电气用品和材料安全法律规定禁止使用未经UL或CSA认证的线材。(线材上会显示UL/CSA符号)。

警告

安装此產品時,請使用本身提供的或指定的或採購的連接線,電源線和電源適配器, 包含遵照當地法規和安全要求的合規的電源線尺寸和插頭.使用其它線材或適配器可能會引起故障或火災。除了Supermicro所指定的產品,電氣用品和材料安全法律規定禁止使用未經UL或CSA認證的線材。(線材上會顯示UL/CSA符號)。

Warnung

Nutzen Sie beim Installieren des Produkts ausschließlich die von uns zur Verfügung gestellten Verbindungskabeln, Stromkabeln und/oder Adapter, die Ihre örtlichen Sicherheitsstandards einhalten. Der Gebrauch von anderen Kabeln und Adapter können Fehlfunktionen oder Feuer verursachen. Die Richtlinien untersagen das Nutzen von UL oder CAS zertifizierten Kabeln (mit UL/CSA gekennzeichnet), an Geräten oder Produkten die nicht mit Supermicro gekennzeichnet sind.

¡Advertencia!

Cuando instale el producto, utilice la conexión provista o designada o procure cables, Cables de alimentación y adaptadores de CA que cumplan con los códigos locales y los requisitos de seguridad, incluyendo el tamaño adecuado del cable y el enchufe. El uso de otros cables y adaptadores podría causar un mal funcionamiento o un incendio. La Ley de Seguridad de Aparatos Eléctricos y de Materiales prohíbe El uso de cables certificados por UL o CSA (que tienen el certificado UL / CSA en el código) para cualquier otros dispositivos eléctricos que los productos designados únicamente por Supermicro.

Attention

Lors de l'installation du produit, utilisez les cables de connection fournis ou désigné ou achetez des cables, cables de puissance et adaptateurs respectant les normes locales et les conditions de securite y compris les tailles de cables et les prises electriques appropries. L'utilisation d'autres cables et adaptateurs peut provoquer un dysfonctionnement ou un incendie. Appareils électroménagers et la Loi sur la Sécurité Matériel interdit l'utilisation de câbles certifiés- UL ou CSA (qui ont UL ou CSA indiqué sur le code) pour tous les autres appareils électriques sauf les produits désignés par Supermicro seulement.

AC ימאתמו םיילמשח םילבכ

!הרהזא

ךרוצל ומאתוה וא ושכרנ רשא AC םימאתמו םיקפס, םילבכב שמתשהל שי, רצומה תא םיניקתמ רשאכ לכב שומיש . עקתהו לבכה לש הנוכנ הדימ ללוכ, תוימוקמה תוחיטבה תושירדל ומאתוה רשאו, הנקתהה למשחה ירישכמב שומישה יקוחל מאתהב. ילמשח רצק וא הלקתל םורגל לולע, רחא גוסמ מאתמ וא לבכ לש דוק םהילע עיפומ רשאכ) UL-ב או CSA-ב ו- UL ב- םיכמסומה םילבכב שמתשהל רוסיא םייק, תוחיטבה יקוחו דבלב Supermicro י"ע מאתוה רשא רצומב קר אלא, רחא ילמשח רצומ לכ רובע (UL/CSA)

תאלבאלא אארשב מץ וא ףדדחמלא וא ףרפוטמלא תאלויסוטלא מאדחטסאב מץ, ןגתנמלא בייגרת דנע לכלז יפ אמב ףילחמלא ףמאלסלא תאבלטתמו נינאוץב מאזתלאלא עמ דדרתמלא ראיטלא תאלווחמו ףיזאברמלא ףיירח וא לטע יפ בבסטטי דץ ירזא תאלווחמו תאלבאלא יא מאדחטסא. מילסלא סבאלאו לטוומלא מץח CSA וא UL לבץ נמ ףדמטעמלא תאלבאלא מאדחטסא תאדעמלא ףיזאברמלא ףזחאלל ףמאלסלא נונאץ רזחי Supermicro לבץ נמ ףדדחמלא ףינעמלא תאגתנמלא ריזג ירזא תאדעמ יא עמ (UL/CSA) ףמאלע למחט יטלאו

전원 케이블 및 AC 어댑터

경고! 제품을 설치할 때 현지 코드 및 적절한 굵기의 코드와 플러그를 포함한 안전 요구 사항을 준수하여 제공되거나 지정된 연결 혹은 구매 케이블, 전원 케이블 및 AC 어댑터를 사용하십시오.

다른 케이블이나 어댑터를 사용하면 오작동이나 화재가 발생할 수 있습니다. 전기 용품 안전법은 UL 또는 CSA 인증 케이블 (코드에 UL / CSA가 표시된 케이블)을 Supermicro가 지정한 제품 이외의 전기 장치에 사용하는 것을 금지합니다.

Stroomkabel en AC-Adapter

Waarschuwing! Bij het aansluiten van het Product uitsluitend gebruik maken van de geleverde Kabels of een andere geschikte aan te schaffen Aansluitmethode, deze moet altijd voldoen aan de lokale voorschriften en veiligheidsnormen, inclusief de juiste kabeldikte en stekker. Het gebruik van niet geschikte Kabels en/of Adapters kan een storing of brand veroorzaken. Wetgeving voor Elektrische apparatuur en Materiaalveiligheid verbied het gebruik van UL of CSA -gecertificeerde Kabels (met UL/CSA in de code) voor elke andere toepassing dan de door Supermicro hiervoor beoogde Producten.

Appendix C

System Specifications

Processors

Dual Intel Xeon Scalable-SP and 2nd Gen Intel Xeon Scalable-SP processors (Socket P) with three Intel® UltraPath Interconnect (UPI) links of up to 10.4 GT/s

Note: Please refer to the motherboard specifications pages on our website for updates to supported processors.

Chipset

Intel C621 chipset

BIOS

AMI® 32Mb SPI Flash ROM

Memory

Integrated memory controller embedded in the processor supports up to 4TB of 3DS Load Reduced DIMM (3DS LRDIMM), 3DS Registered DIMM (3DS RDIMM), or up to 2TB of Load Registered DIMM (LRDIMM), with speeds of 2933*/2666/2400/2133/1866/1600/1333 MHz modules in 16 memory slots.

Note: 2933 MHz memory is supported by 2nd Gen Intel Scalable-SP (82xx/62xx series) processors only. See the memory section in Chapter 3 for details and our website for updates to supported memory.

SATA Controller

On-chip (Intel C621) controller

Drive Bays

Eight hot-swap 3.5" drive bays

PCI Expansion Slots

Four PCI Express 3.0 x16

Two PCI Express 3.0 x16 or HSSI (High Speed Serial Interface)

One PCI Express 3.0 x4 in x8 slot

Motherboard

X11DPG-QT (15.12 x 13.2 in. / 384 x 335.3 mm.)

Chassis

SC-747BTS-R2K20BP; 4U Rackmount/Tower, 7.0 x 18.2 x 26.5 in. / 178 x 462 x 673 mm. (W x H x D)

System Cooling

Four heavy duty fans

Two rear exhaust fans

Two optional fans for passive GPUs

Power Supply

Model: 2200W Redundant Power Supplies Titanium Level Efficiency

Rated Input Current: 14A (100V) to 11A (240V)

Rated Input Frequency: 50-60 Hz

Rated Output Power: 2200W

Rated Output Voltages: +12V (183.3A), +5Vsb (6A)

Operating Environment

Operating Temperature: 10° to 35° C (50° to 95° F)

Non-operating Temperature: -40° to 60° C (-40° to 140° F)

Operating Relative Humidity: 8% to 90% (non-condensing)

Non-operating Relative Humidity: 5% to 95% (non-condensing)

Regulatory Compliance

Electromagnetic Emissions: FCC Class A, EN 55032 Class A, EN 61000-3-2/3-3, CISPR 32 Class A, FCC, ICES, CE, VCCI, RCM, NRTL, CB

Electromagnetic Immunity: EN 55024/CISPR 24, (EN 61000-4-2, EN 61000-4-3, EN 61000-4-4, EN 61000-4-5, EN 61000-4-6, EN 61000-4-8, EN 61000-4-11)

Safety: CSA/EN/IEC/UL 60950-1 Compliant, UL or CSA Listed (USA and Canada), CE Marking (Europe)

Other: VCCI-CISPR 32 and AS/NZS CISPR 32

Environmental: Directive EMC (2014/30/EU) and LVD/Safety (2014/35/EU)

Applied Directives, Standards

EMC/EMI: 2014/30/EU (EMC Directive)

FCC Part 15

ICES-003

VCCI 32-1

AS/NZS CISPR 32

EN55032

EN55035

CISPR 24

EN 61000-3-2

EN 61000-3-3

EN 61000-4-2

EN 61000-4-3

EN 61000-4-4

EN 61000-4-5

EN 61000-4-6

EN 61000-4-8

EN 61000-4-11

Green Environment:

2011/65/EU (RoHS Directive)

EC 1907/2006 (REACH)

2012/19/EU (WEEE Directive)

Product Safety: 2014/35/EU (LVD Directive)

UL/CSA 60950-1, 62368-1 (USA and Canada)

IEC/EN 60950-1, 62368-1

Perchlorate Warning

California Best Management Practices Regulations for Perchlorate Materials: This Perchlorate warning applies only to products containing CR (Manganese Dioxide) Lithium coin cells. "Perchlorate Material-special handling may apply. See www.dtsc.ca.gov/hazardouswaste/perchlorate"

Appendix D

UEFI BIOS Recovery

Warning: Do not upgrade the BIOS unless your system has a BIOS-related issue. Flashing the wrong BIOS can cause irreparable damage to the system. In no event shall Supermicro be liable for direct, indirect, special, incidental, or consequential damages arising from a BIOS update. If you need to update the BIOS, do not shut down or reset the system while the BIOS is updating to avoid possible boot failure.

D.1 Overview

The Unified Extensible Firmware Interface (UEFI) provides a software-based interface between the operating system and the platform firmware in the pre-boot environment. The UEFI specification supports an architecture-independent mechanism that will allow the UEFI OS loader stored in an add-on card to boot the system. The UEFI offers clean, hands-off management to a computer during system boot.

D.2 Recovering the UEFI BIOS Image

A UEFI BIOS flash chip consists of a recovery BIOS block and a main BIOS block (a main BIOS image). The recovery block contains critical BIOS codes, including memory detection and recovery codes for the user to flash a healthy BIOS image if the original main BIOS image is corrupted. When the system power is turned on, the recovery block codes execute first. Once this process is complete, the main BIOS code will continue with system initialization and the remaining POST (Power-On Self-Test) routines.

Note 1: Follow the BIOS recovery instructions below for BIOS recovery when the main BIOS block crashes.

Note 2: When the BIOS recovery block crashes, you will need to follow the procedures to make a Returned Merchandise Authorization (RMA) request. (For a RMA request, please see section 3.5 for more information). Also, you may use the Supermicro Update Manager (SUM) Out-of-Band (OOB) (https://www.supermicro.com.tw/products/nfo/SMS_SUM.cfm) to reflash the BIOS.

D.3 Recovering the Main BIOS Block with a USB Device

This feature allows the user to recover the main BIOS image using a USB-attached device without additional utilities used. A USB flash device such as a USB Flash Drive, or a USB

CD/DVD ROM/RW device can be used for this purpose. However, a USB Hard Disk drive cannot be used for BIOS recovery at this time.

The file system supported by the recovery block is FAT (including FAT12, FAT16, and FAT32) which is installed on a bootable or non-bootable USB-attached device. However, the BIOS might need several minutes to locate the SUPER.ROM file if the media size becomes too large due to the huge volumes of folders and files stored in the device.

To perform UEFI BIOS recovery using a USB-attached device, follow the instructions below.

1. Using a different machine, copy the "Super.ROM" binary image file into the Root "\" directory of a USB device or a writable CD/DVD.

Notes: 1. If you cannot locate the "Super.ROM" file in your drive disk, visit our website at www.supermicro.com to download the BIOS package. Extract the BIOS binary image into a USB flash device and rename it "Super.ROM" for the BIOS recovery use. 2. Before recovering the main BIOS image, confirm that the "Super.ROM" binary image file you download is the same version or a close version meant for your motherboard.

2. Insert the USB device that contains the new BIOS image ("Super.ROM") into your USB drive and reset the system when the following screen appears.



3. After locating the healthy BIOS binary image, the system will enter the BIOS Recovery menu as shown below.

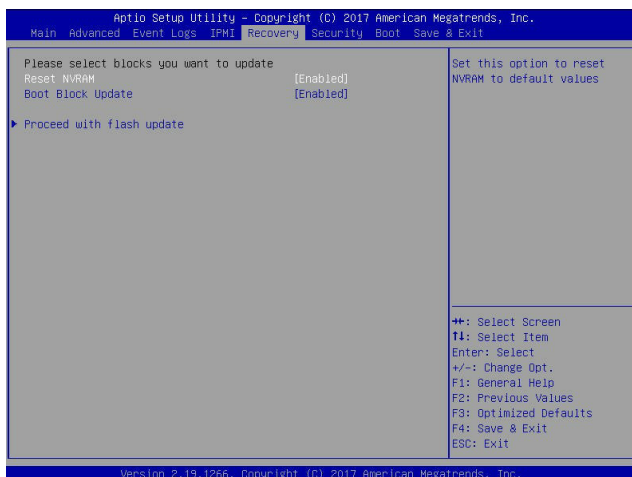

Note: At this point, you may decide if you want to start the BIOS recovery. If you decide to proceed with BIOS recovery, follow the procedures below.

4. When the screen as shown above displays, use the arrow keys to select the item "Proceed with flash update" and press the <Enter> key. You will see the BIOS recovery progress as shown in the screen below.

Note: Do not interrupt the BIOS flashing process until it has completed.

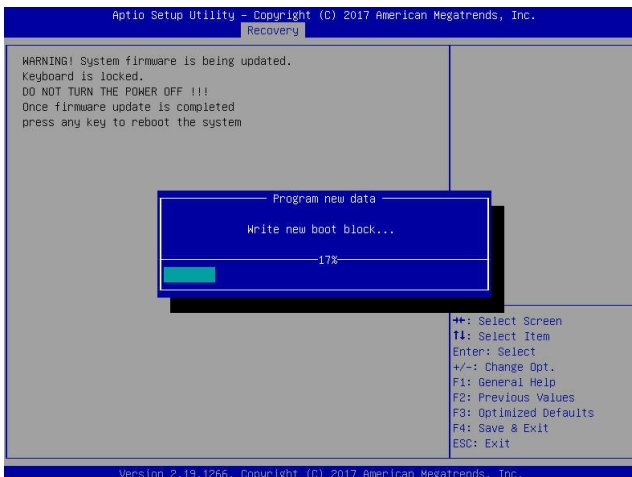

- After the BIOS recovery process is complete, press any key to reboot the system.

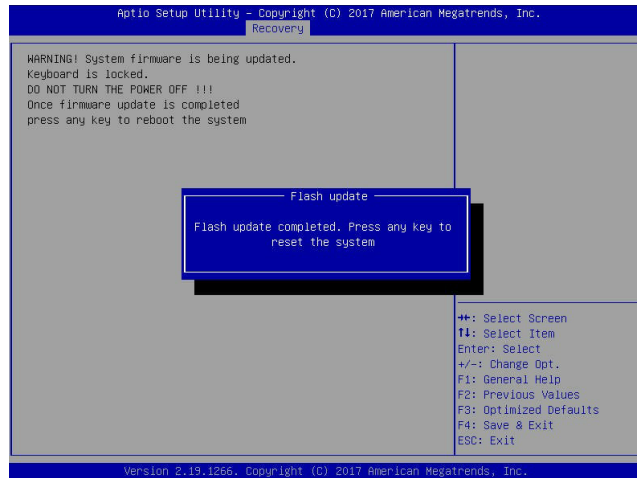

- Using a different system, extract the BIOS package into a USB flash drive.
- Press continuously during system boot to enter the BIOS Setup utility. From the top of the tool bar, select Boot to enter the submenu. From the submenu list, select Boot Option #1 as shown below. Then, set Boot Option #1 to [UEFI AP:UEFI: Built-in EFI Shell]. Press <F4> to save the settings and exit the BIOS Setup utility.

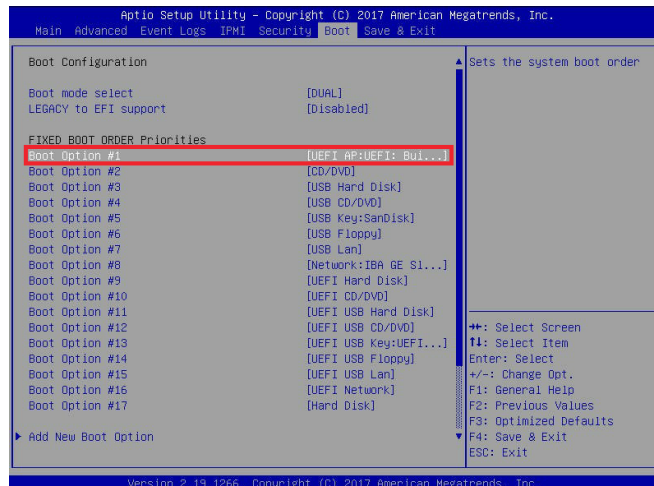

8. When the UEFI Shell prompt appears, type `fs#` to change the device directory path. Go to the directory that contains the BIOS package you extracted earlier from Step 6. Enter `flash.nsh BIOSname.###` at the prompt to start the BIOS update process.

```

UEFI Interactive Shell v2.1
EDK II
UEFI v2.50 (American Megatrends, 0x0005000C)
Mapping Table
FS0: Alias(s):HD0:00:BLK1:
      PciRoot(0x0)/Pci(0x14,0x0)/USB(0x11,0x0)/HD(1,MBR,0x3791072,0x800,0x1
DR959C)
      BLK0: Alias(s):
      PciRoot(0x0)/Pci(0x14,0x0)/USB(0x11,0x0)
Press F8 in 1 seconds to skip startup.nsh or any other key to continue.
Shell> fs0:
FS0:\> cd \AFUDOS
FS0:\AFUDOS> cd SNIJPE2_03162017
FS0:\AFUDOS\SNIJPE2_03162017> flash.nsh X110PU7_314

```

Note: *Do not interrupt this process* until the BIOS flashing is complete.

```

Done.
[ Access Cmos Port Ex ]
<Read>
Index 0x51: 0x10

Done.
*****
* Program BIOS and ME (including FDT) regions...
*****
| AMT Firmware Update Utility v5.09.01.1917
| Copyright (C)2017 American Megatrends Inc. All Rights Reserved.
|-----|
CPUID = 50652

Reading flash ..... done
- ME Data Size checking - ok
- FFS checksums ..... ok
- Check RomLayout ..... Ok
Erasing Boot Block ..... done
Updating Boot Block ..... done
Verifying Boot Block ..... done
_Erasing Main Block ..... 0x00132000 (0x)

```

9. The screen above indicates that the BIOS update process is complete. When you see the screen above, unplug the AC power cable from the power supply, clear CMOS, and plug the AC power cable in the power supply again to power on the system.

```

Verifying NDB Block ..... done
- Update success for FDR
- Update success for IE
- Successful Update Recovery Loader to OPRx11
- Successful Update MFSB11
- Successful Update FPR11
- Successful Update MFS, IVB1 and IVB211
- Successful Update FLOG and UTDK11
- ME Entire Image update success !!
WARNING : System must power-off to have the changes take effect!
Moving FS0:\AFUDOS\SNIJPE2_03162017\Fdtv64.efi -> FS0:\AFUDOS\SNIJPE2_03162017\F
dt1.smc
- [ok]
Moving FS0:\AFUDOS\SNIJPE2_03162017\Fuef1x64.efi -> FS0:\AFUDOS\SNIJPE2_0316201
7\Fuef1.smc
- [ok]
*****
* Please ignore this 'Shell: Cannot read from file - Device Error'
* warning message due to it does not impact flashing process.
*****
Deleting "FS0:\uef1.smc"
Delete successful.
FS0:\>

```

10. Press `` continuously to enter the BIOS Setup utility.
11. Press `<F3>` to load the default settings.
12. After loading the default settings, press `<F4>` to save the settings and exit the BIOS Setup utility.

Appendix E

BSMI RoHS

Additional Traditional Chinese Version warning statements are included here in this appendix.

安全警告 (注意這些警告標誌)

以下的警告標誌對於安全使用本設備非常重要，可以避免操作人員遭遇危險，以及財產受到任何損失。

錯誤使用本機器或忽視這本手冊，所引起的傷害或損失等級分類如下：



Warning! (警告) 此注意標誌提醒未能依照正確指示使用機器，可能導致生命危險 或造成嚴重傷害。



Caution (注意) 此注意標誌提醒未能依照正確指示使用機器，可能導致受傷 或財產損失。



此標誌提示絕對不可做的動作。



此標誌提示一般性務必要採取的行為。



Warnings: (警告)



本機器必須用接地線與地面確實連接。否則受到電擊或閃電時，將對您造成危險。如果電源插座沒有接地端子，或是有無法接地情況，請務必洽詢專業技術人員，妥善安裝這些設施。



1. 電源必須在 100V 至 240V 正負 10%之間
2. 使用額定合格開關來提供電源迴路。
3. 機器安裝愈接近電源插座愈好。
4. 移動機器必須由維護工程師來處理。



1. 勿使用多孔插座或延長線，否則可能造成溫度過高而引起火災。
2. 勿在電源線放置重物，否則可能引起火災或受到電擊。
3. 勿踏在電源線上，及勿損傷或任意處理電源線，否則可能引起火災或受到電擊。
4. 勿綁住或紮緊電源線，否則可能引起火災或受到電擊。
5. 勿將花瓶、花盆或盛水容器放在機器上，如果水滴濺出，可能引起火災或受到電擊。



1. 機器如果產生怪味或不正常聲響，必需立即關閉機器電源開關，然後從插座取下插頭。
2. 絕對不可以沾濕的手插拔插頭，否則可能受到電擊。
3. 插頭必須確實插妥在插座上，如果未能妥善插好，可能會引起火災。
4. 僅可使用機器所附電源插頭。



拔取電源線時，確實抓住插頭部位，否則導致插頭破裂可能引起火災或受到電擊。



不可企圖拆解或擅自修改機器，否則可能引起火災或受到電擊。



不可將機器安裝在下列場所：

1. 濕氣高及多灰塵的地方。
2. 地板不穩的地方。如果機器傾倒，可能造成傷害。



關閉上機蓋時，千萬不可將手放在上機蓋與主機體之間。



1. 移動機器前，必須記住拔下插頭，否則插頭可能受損而引起火災或受到電擊。
2. 為安全起見，夜晚無人使用伺服器時，必須確實將它的電源關閉。
3. 連續假日長期無人使用伺服器時，必須確實將它的電源關閉。
4. 插座周圍必須淨空，以便隨時可以很輕易的拔下插頭。



警告使用者：
這是甲類的資訊產品，在居住的環境中使用時，可能會造成射頻干擾，在這種情況下，使用者會被要求採取某些適當的對策

限用物質含有情況標示聲明書

Declaration of the Presence Condition of the Restricted Substances Marking

設備名稱：超級工作站/SuperWorkstation 型號（型式）：747-22 （系列型號：SYS-7049GP-TRT ,747-12） Equipment name Type designation (Type)						
單元 Unit	限用物質及其化學符號 Restricted substances and its chemical symbols					
	鉛Lead (Pb)	汞Mercury (Hg)	鎘Cadmium (Cd)	六價鉻Hexavalent chromium (Cr ⁺⁶)	多溴聯苯Polybrominated biphenyls (PBB)	多溴二苯醚Polybrominated diphenyl ethers (PBDE)
機殼 (Chassis)	○	○	○	○	○	○
機殼風扇 (Chassis Fan)	—	○	○	○	○	○
線材 (Cable)	○	○	○	○	○	○
主機板 (Motherboard)	—	○	○	○	○	○
電源供應器 (Power Supply)	—	○	○	○	○	○
硬碟 (Hard Disk)	—	○	○	○	○	○
電源背板 (PDB)	—	○	○	○	○	○
附加卡 (Add-on Card)	—	○	○	○	○	○
備考1. “超出0.1 wt %” 及 “超出0.01 wt %” 係指限用物質之百分比含量超出百分比含量基準值。 Note 1 : “Exceeding 0.1 wt %” and “exceeding 0.01 wt %” indicate that the percentage content of the restricted substance exceeds the reference percentage value of presence condition.						
備考2. “○” 係指該項限用物質之百分比含量未超出百分比含量基準值。 Note 2 : “○” indicates that the percentage content of the restricted substance does not exceed the percentage of reference value of presence.						
備考3. “—” 係指該項限用物質為排除項目。 Note 3 : The “—” indicates that the restricted substance corresponds to the exemption.						

*輸入額定：

747-22 & SYS-7049GP-TRT

100-127V ~, 60-50Hz, 12-11A

200-240V ~, 60-50Hz, 10-9.8A

747-12

100-127V ~, 60-50Hz, 12-10A

200-240V ~, 60-50Hz, 8.5-7A

*使用者不能任意拆除或替換內部配備

*設備名稱：超級工作站

*報驗義務人之姓名或名稱：美超微電腦股份有限公司

*報驗義務人之地址：新北市中和區建一路150號3樓