

# SUPERO<sup>®</sup>

SuperServer

4027GR-TR

4027GR-TRT

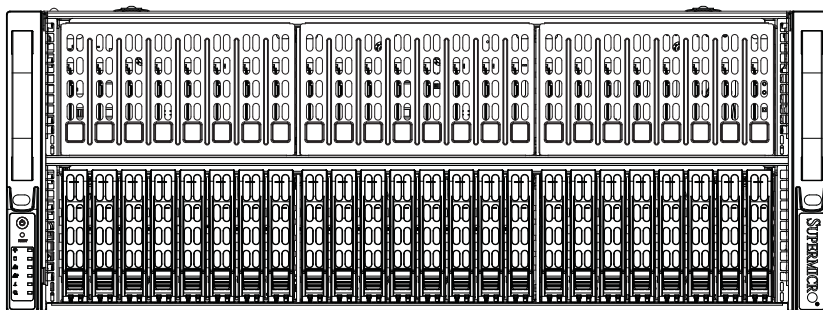

## USER'S MANUAL

Revision 1.0

The information in this User's Manual has been carefully reviewed and is believed to be accurate. The vendor assumes no responsibility for any inaccuracies that may be contained in this document, makes no commitment to update or to keep current the information in this manual, or to notify any person or organization of the updates. **Please Note: For the most up-to-date version of this manual, please see our web site at [www.supermicro.com](http://www.supermicro.com).**

Super Micro Computer, Inc. ("Supermicro") reserves the right to make changes to the product described in this manual at any time and without notice. This product, including software and documentation, is the property of Supermicro and/or its licensors, and is supplied only under a license. Any use or reproduction of this product is not allowed, except as expressly permitted by the terms of said license.

IN NO EVENT WILL SUPERMICRO BE LIABLE FOR DIRECT, INDIRECT, SPECIAL, INCIDENTAL, SPECULATIVE OR CONSEQUENTIAL DAMAGES ARISING FROM THE USE OR INABILITY TO USE THIS PRODUCT OR DOCUMENTATION, EVEN IF ADVISED OF THE POSSIBILITY OF SUCH DAMAGES. IN PARTICULAR, SUPERMICRO SHALL NOT HAVE LIABILITY FOR ANY HARDWARE, SOFTWARE, OR DATA STORED OR USED WITH THE PRODUCT, INCLUDING THE COSTS OF REPAIRING, REPLACING, INTEGRATING, INSTALLING OR RECOVERING SUCH HARDWARE, SOFTWARE, OR DATA.

Any disputes arising between manufacturer and customer shall be governed by the laws of Santa Clara County in the State of California, USA. The State of California, County of Santa Clara shall be the exclusive venue for the resolution of any such disputes. Super Micro's total liability for all claims will not exceed the price paid for the hardware product.

FCC Statement: This equipment has been tested and found to comply with the limits for a Class A digital device pursuant to Part 15 of the FCC Rules. These limits are designed to provide reasonable protection against harmful interference when the equipment is operated in a commercial environment. This equipment generates, uses, and can radiate radio frequency energy and, if not installed and used in accordance with the manufacturer's instruction manual, may cause harmful interference with radio communications. Operation of this equipment in a residential area is likely to cause harmful interference, in which case you will be required to correct the interference at your own expense.

California Best Management Practices Regulations for Perchlorate Materials: This Perchlorate warning applies only to products containing CR (Manganese Dioxide) Lithium coin cells. "Perchlorate Material-special handling may apply. See [www.dtsc.ca.gov/hazardouswaste/perchlorate](http://www.dtsc.ca.gov/hazardouswaste/perchlorate)"

**WARNING: Handling of lead solder materials used in this product may expose you to lead, a chemical known to the State of California to cause birth defects and other reproductive harm.**

Manual Revision 1.0

Release Date: March 12, 2014

Unless you request and receive written permission from Super Micro Computer, Inc., you may not copy any part of this document.

Information in this document is subject to change without notice. Other products and companies referred to herein are trademarks or registered trademarks of their respective companies or mark holders.

Copyright © 2014 by Super Micro Computer, Inc.  
All rights reserved.

**Printed in the United States of America**

# Preface

## About This Manual

This manual is written for professional system integrators and PC technicians. It provides information for the installation and use of the SuperServer 4027GR-TR/TRT. Installation and maintenance should be performed by experienced technicians only.

The SuperServer 4027GR-TR/TRT is a high-end server based on the SC418GTS-R3200B 4U rackmount chassis and the dual processor X9DRG-OF/OTFserverboard.

## Manual Organization

### Chapter 1: Introduction

The first chapter provides a checklist of the main components included with the server system and describes the main features of the X9DRG-OF/OTFserverboard and the SC418GTS-R3200B chassis.

### Chapter 2: Server Installation

This chapter describes the steps necessary to install the SuperServer 4027GR-TR/TRT into a rack and check out the server configuration prior to powering up the system. If your server was ordered without processor and memory components, this chapter will refer you to the appropriate sections of the manual for their installation.

### Chapter 3: System Interface

Refer here for details on the system interface, which includes the functions and information provided by the control panel on the chassis as well as other LEDs located throughout the system.

### Chapter 4: Standardized Warning Statements

You should thoroughly familiarize yourself with this chapter for a general overview of safety precautions that should be followed when installing and servicing the SUPERSERVER 4027GR-TR/TRT.

### Chapter 5: Advanced Serverboard Setup

Chapter 5 provides detailed information on the X9DRG-OF/OTFserverboard, including the locations and functions of connections, headers and jumpers. Refer to this chapter when adding or removing processors or main memory and when reconfiguring the serverboard.

## **Chapter 6: Advanced Chassis Setup**

Refer to Chapter 6 for detailed information on the SC418GTS-R3200B server chassis. You should follow the procedures given in this chapter when installing, removing or reconfiguring SATA or peripheral drives and when replacing system power supply units and cooling fans.

## **Chapter 7: BIOS**

The BIOS chapter includes an introduction to BIOS and provides detailed information on running the CMOS Setup Utility.

## **Appendix A: BIOS Error Beep Codes**

## **Appendix B: System Specifications**

## Notes

## Table of Contents

### **Chapter 1 Introduction**

1-1	Overview .....	1-1
1-2	Serverboard Features .....	1-2
	Processors .....	1-2
	Memory .....	1-2
	Serial ATA .....	1-2
	PCI Expansion Slots .....	1-2
	Rear I/O Ports .....	1-2
	Graphics Controller .....	1-3
1-3	Server Chassis Features .....	1-3
	System Power .....	1-3
	SATA Subsystem .....	1-3
	Front Control Panel .....	1-3
	Cooling System .....	1-3
	Air Shrouds .....	1-3
	Mounting Rails .....	1-4
1-4	GPU Subsystem .....	1-6
1-5	Contacting Supermicro .....	1-7

### **Chapter 2 Rack Installation**

2-1	Overview .....	2-1
2-2	Unpacking the System .....	2-1
2-3	Preparing for Setup .....	2-1
	Choosing a Setup Location .....	2-1
2-4	Warnings and Precautions .....	2-2
	Rack Precautions .....	2-2
	General Server Precautions .....	2-2
	Rack Mounting Considerations .....	2-3
	Ambient Operating Temperature .....	2-3
	Reduced Airflow .....	2-3
	Mechanical Loading .....	2-3
	Circuit Overloading .....	2-3
	Reliable Ground .....	2-3
2-5	Rack Mounting Instructions .....	2-4
	Identifying the Sections of the Rack Rails .....	2-4
	Locking Tabs .....	2-5
	Releasing the Inner Rail .....	2-5
	Installing The Inner Rails on the Chassis .....	2-6

---

Installing the Outer Rails on the Rack .....	2-7
Standard Chassis Installation .....	2-8
Optional Quick Installation Method .....	2-9
<b>Chapter 3 System Interface</b>	
3-1 Overview .....	3-1
3-2 Control Panel Buttons .....	3-2
3-3 Control Panel LEDs .....	3-2
3-4 Drive Carrier LEDs .....	3-4
<b>Chapter 4 Standardized Warning Statements for AC Systems</b>	
4-1 About Standardized Warning Statements .....	4-1
Warning Definition .....	4-1
Installation Instructions .....	4-4
Circuit Breaker .....	4-5
Power Disconnection Warning .....	4-6
Equipment Installation .....	4-8
Restricted Area .....	4-9
Battery Handling .....	4-10
Redundant Power Supplies .....	4-12
Backplane Voltage .....	4-13
Comply with Local and National Electrical Codes .....	4-14
Product Disposal .....	4-15
Hot Swap Fan Warning .....	4-16
Power Cable and AC Adapter .....	4-18
<b>Chapter 5 Advanced Serverboard Setup</b>	
5-1 Handling the Serverboard .....	5-1
Precautions .....	5-1
Unpacking .....	5-1
5-2 Connecting Cables .....	5-2
Connecting Data Cables .....	5-2
5-3 Control Panel Connectors and I/O Ports .....	5-3
Connecting the Control Panel .....	5-4
5-4 Processor and Heatsink Installation .....	5-5
Installing the LGA2011 Processor .....	5-5
Installing a Passive CPU Heatsink .....	5-10
Removing the Heatsink .....	5-11
5-5 Installing Memory .....	5-12
Installing Memory .....	5-12
Memory Support .....	5-12
5-6 Adding PCI Expansion Cards .....	5-16

---

---

---

5-7	Serverboard Details .....	5-16
	X9DRG-OF/OTF Quick Reference.....	5-18
5-8	Connector Definitions.....	5-21
5-9	Jumper Settings .....	5-27
	Explanation of Jumpers .....	5-27
5-10	Onboard Indicators.....	5-29
5-11	SATA Ports.....	5-31
5-12	Installing Software.....	5-32
	SuperDoctor III.....	5-33
5-13	Onboard Battery.....	5-35

### **Chapter 6 Advanced Chassis Setup**

6-1	Static-Sensitive Devices.....	6-1
	Precautions .....	6-1
	Unpacking .....	6-1
6-2	Control Panel .....	6-2
6-3	Installing Hard Drives.....	6-3
6-4	Accessing the Inside of the System.....	6-5
	Removing the Chassis Cover .....	6-5
6-5	Installing the Air Shroud.....	6-6
	Air Shrouds .....	6-6
6-6	Cooling System.....	6-8
6-7	Power Supply .....	6-9
	Power Supply Replacement.....	6-9

### **Chapter 7 BIOS**

7-1	Introduction.....	7-1
	Starting BIOS Setup Utility.....	7-1
	How To Change the Configuration Data.....	7-2
	Starting the Setup Utility .....	7-2
7-2	Main Setup.....	7-2
7-3	Advanced Setup Configurations.....	7-4
7-4	Event Logs.....	7-25
7-5	IPMI.....	7-27
7-6	Boot.....	7-29
7-7	Security.....	7-31
7-8	Save & Exit .....	7-32

### **Appendix A BIOS Error Beep Codes**

### **Appendix B System Specifications**

# Chapter 1

## Introduction

### 1-1 Overview

The SuperServer 4027GR-TR/TRT is a high-end GPU-optimized server comprised of two main subsystems: the SC418GTS-R3200B 4U server chassis, the X9DRG-OF/OTF dual processor serverboard and the X9DRG-O-PCIE I/O board. Please refer to our web site for information on operating systems that have been certified for use with the system ([www.supermicro.com](http://www.supermicro.com)).

In addition to the serverboard and chassis, various hardware components have been included with the SuperServer 4027GR-TR/TRT server, as listed below:

- Two passive heatsinks (SNK-P0048PS)
- Two air shrouds (MCP-310-41806-0B, MCP-310-41807-0B)
- Four riser cards (RSC-X9DRG-O-O-P)
- Eight 92 x 92 x 38-mm, 11.5K RPM, PWM fans (FAN-0115L4)
- One SATA backplane (BPN-SAS3-216A)  
Twenty-four hot-swap 2.5" HDD trays (MCP-220-00047-0B)
- One rail set (MCP-290-00057-0N)
- One SuperServer 4027GR-TR/TRT Quick Reference Guide

**Note:** For your system to work properly, please follow the links below to download all necessary drivers/utilities and the user's manual for your server.

- Supermicro product manuals: <http://www.supermicro.com/support/manuals/>
- Product drivers and utilities: <ftp://ftp.supermicro.com>
- Product safety info: [http://super-dev/about/policies/safety\\_information.cfm](http://super-dev/about/policies/safety_information.cfm)
- If you have any questions, please contact our support team at: [support@supermicro.com](mailto:support@supermicro.com)

## 1-2 Serverboard Features

At the heart of the SuperServer 4027GR-TR/TRT lies the X9DRG-OF/OTF, a dual processor serverboard based on the Intel® C602 PCH chipset and designed to provide maximum performance.

The sections below cover the main features of the X9DRG-OF/OTF serverboard (see Figure 1-1 for a block diagram of the chipset).

### Processors

The X9DRG-OF/OTF supports two Intel® Xeon® E5-2600 or E5-2600 v2 series processors (Socket R LGA 2011). Please refer to the serverboard description pages on our web site for a complete listing of supported processors ([www.supermicro.com](http://www.supermicro.com)).

Note: For Intel E5-2600 (v2) processor support, BIOS version 3.0 or above is required.

### Memory

The X9DRG-OF/OTF has 24 DIMM slots to support up to 1.5 TB of LRDIMM. 768 GB of RDIMM or 128 GB of ECC/non-ECC UDIMM DDR3-1600/1333/1066/800 memory. See Chapter 5 for details. Note that 1600 MHz memory speed is dependent on Intel E5-2600 (v2) CPUs.

**Note:** Check the Supermicro website ([www.supermicro.com](http://www.supermicro.com)) for the latest memory support information.

### Serial ATA

A Serial ATA controller is integrated into the C602 to provide two SATA 3.0 ports (I-SATA 0/1) and eight SATA 2.0 ports (I-SATA 2~5 from AHCI, S-SATA 1~4 from SCU) that support RAID 0, 1, 5 and 10. The SATA drives are hot-swappable units.

### PCI Expansion Slots

The 4027GR-TR/TRT has eight PCI Express 3.0 x16 slots, two PCI Express x8 slots (in x16 slots) and one PCI Express 2.0 x4 (in a x16 slot) slot on the X9DRG-OF/OTF.

### Rear I/O Ports

The I/O ports on the rear of the serverboard include a VGA (monitor) port, four USB 2.0 ports (USB0/1 and USB2/3), two Ethernet LAN ports and a dedicated IPMI LAN port.

**Note:** For IPMI configuration instructions, refer to the Embedded BMC Configuration User's Guide at <http://www.supermicro.com/support/manuals/>.

## **Graphics Controller**

The X9DRG-OF/OTF features a Matrox G200 video controller.

## **1-3 Server Chassis Features**

The following is a general outline of the main features of the SC418 server chassis.

### **System Power**

The SC418 chassis model includes four high-efficiency 80-plus Platinum certified power supplies, rated at 1600 Watts each for a total of 6400 Watts providing plenty of power for high wattage GPU cards. The power supplies are 2+2 redundancy. In the unlikely event your power supply fails, replacement is simple and can be accomplished without tools.

### **SATA Subsystem**

The SC418 supports up to twenty-four 2.5" hot-swap hard drives. These drives are connected to a backplane that provides power and control.

### **Front Control Panel**

The SC418 chassis includes a control panel on the handle of the chassis to control the system. The control panel on the provides you with system monitoring and control. LEDs indicate system power, HDD activity, network activity, system overheat and power supply failure. A main power button and a system reset button are also included.

### **Cooling System**

Eight 9-cm fans are used to cool the system. Fan speed is controlled via IPMI.

### **Air Shrouds**

The SC418 chassis includes two mylar air shrouds that direct the airflow where cooling is needed. Always use the air shrouds included with your server.



Figure 1-2. PCI-E Card Block Diagram

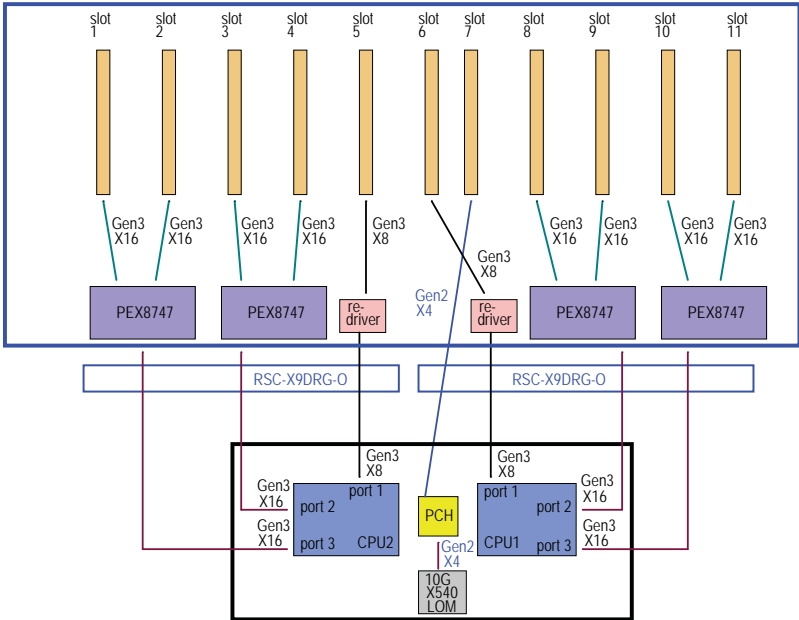

**Note:** This PCI-E card block diagram may not exactly represent the features on your serverboard. See the Chapter 5 for the actual specifications of each serverboard.

## 1-4 GPU Subsystem

The 4027GR-TR/TRT server represents one of Supermicro's massively parallel processing multiple-GPU servers, with support for up to eight GPUs. NVIDIA® Kepler™ GPUs place this system at the forefront of today's GPU computing solutions.

Please refer to the NVIDIA web site ([www.nvidia.com](http://www.nvidia.com)) for details on Kepler GPUs.

### Notes

The GPUs process complex image calculations and then route the data out through the VGA port on the serverboard.

The 4027GR-TR/TRT can support eight standard size (double-width) GPUs.

NVIDIA® Kepler™ K10/K20/K20X/K40 GPUs, which come with a passive heatsink attached, have been tested for use with this system. Any combination of these cards (up to a total of eight) may have come bundled with the system

### Power Notes

To provide power to the GPU cards, connect the GPU power cable (CBL-PWEX-0582) from each of the GPUs to JPW3/JPW13/JPW14/JPW15/JPW16 and JPW4/JPW12/JPW6/JPW7/JPW5 on the serverboard (one cable for each card).

## 1-5 Contacting Supermicro

### Headquarters

Address: Super Micro Computer, Inc.  
980 Rock Ave.  
San Jose, CA 95131 U.S.A.

Tel: +1 (408) 503-8000

Fax: +1 (408) 503-8008

Email: [marketing@supermicro.com](mailto:marketing@supermicro.com) (General Information)  
[support@supermicro.com](mailto:support@supermicro.com) (Technical Support)

Web Site: [www.supermicro.com](http://www.supermicro.com)

### Europe

Address: Super Micro Computer B.V.  
Het Sterrenbeeld 28, 5215 ML  
's-Hertogenbosch, The Netherlands

Tel: +31 (0) 73-6400390

Fax: +31 (0) 73-6416525

Email: [sales@supermicro.nl](mailto:sales@supermicro.nl) (General Information)  
[support@supermicro.nl](mailto:support@supermicro.nl) (Technical Support)  
[rma@supermicro.nl](mailto:rma@supermicro.nl) (Customer Support)

Web Site: [www.supermicro.com](http://www.supermicro.com)

### Asia-Pacific

Address: Super Micro Computer, Inc.  
3F, No. 150, Jian 1st Rd.  
Zhonghe Dist., New Taipei City 235  
Taiwan (R.O.C)

Tel: +886-(2) 8226-3990

Fax: +886-(2) 8226-3992

Email: [support@supermicro.com.tw](mailto:support@supermicro.com.tw)

Tel: +886-(2)-8226-3990

Web Site: [www.supermicro.com.tw](http://www.supermicro.com.tw)

## Notes

## Chapter 2

# Rack Installation

### 2-1 Overview

This chapter provides a quick setup checklist to get your chassis up and running. Following these steps in the order given should enable you to have the system operational within a minimal amount of time.

### 2-2 Unpacking the System

You should inspect the box which the chassis was shipped in and note if it was damaged in any way. If the chassis itself shows damage, you should file a damage claim with the carrier who delivered it.

Decide on a suitable location for the rack unit that will hold your chassis. It should be situated in a clean, dust-free area that is well ventilated. Avoid areas where heat, electrical noise and electromagnetic fields are generated. The system needs to be placed near a grounded power outlet. Be sure to read the Rack and Server Precautions in the next section.

### 2-3 Preparing for Setup

The box your chassis was shipped in should include two sets of rail assemblies and the mounting screws needed for installing the system into the rack. Also included is an optional square hole to round hole converter bracket, for use in racks with round mounting holes. *Please read this section in its entirety before you begin the installation procedure outlined in the sections that follow.*

#### Choosing a Setup Location

- Leave enough clearance in front of the rack to enable you to open the front door completely (~25 inches).
- Leave approximately 30 inches of clearance in the back of the rack to allow for sufficient airflow and ease in servicing.
- This product is for installation only in a Restricted Access Location (dedicated equipment rooms, service closets and the like).

## 2-4 Warnings and Precautions

### Rack Precautions

- Ensure that the leveling jacks on the bottom of the rack are fully extended to the floor with the full weight of the rack resting on them.
- In single rack installations, stabilizers should be attached to the rack.
- In multiple rack installations, the racks should be coupled together.
- Always make sure that the rack is stable before extending a component from the rack.
- You should extend only one component at a time - extending two or more simultaneously may cause the rack to become unstable.

### General Server Precautions

- Review the electrical and general safety precautions that came with the components you are adding to your chassis.
- Determine the placement of each component in the rack *before* you install the rails.
- Install the heaviest server components on the bottom of the rack first, and then work upwards.
- Use a regulating uninterruptible power supply (UPS) to protect the server from power surges, voltage spikes and to keep your system operating in case of a power failure.
- Allow the hot plug hard drives and power supply modules to cool before touching them.
- Always keep the rack's front door and all panels and components on the servers closed when not servicing to maintain proper cooling.

## Rack Mounting Considerations

### ***Ambient Operating Temperature***

If installed in a closed or multi-unit rack assembly, the ambient operating temperature of the rack environment may be greater than the ambient temperature of the room. Therefore, consideration should be given to installing the equipment in an environment compatible with the manufacturer's maximum rated ambient temperature (TMRA).

### ***Reduced Airflow***

Equipment should be mounted into a rack so that the amount of airflow required for safe operation is not compromised.

### ***Mechanical Loading***

Equipment should be mounted into a rack so that a hazardous condition does not arise due to uneven mechanical loading.

### ***Circuit Overloading***

Consideration should be given to the connection of the equipment to the power supply circuitry and the effect that any possible overloading of circuits might have on overcurrent protection and power supply wiring. Appropriate consideration of equipment nameplate ratings should be used when addressing this concern.

### ***Reliable Ground***

A reliable ground must be maintained at all times. To ensure this, the rack itself should be grounded. Particular attention should be given to power supply connections other than the direct connections to the branch circuit (i.e. the use of power strips, etc.).



**Warning!** To prevent bodily injury when mounting or servicing this unit in a rack, you must take special precautions to ensure that the system remains stable. The following guidelines are provided to ensure your safety:

- This unit should be mounted at the bottom of the rack if it is the only unit in the rack.
- When mounting this unit in a partially filled rack, load the rack from the bottom to the top with the heaviest component at the bottom of the rack.
- If the rack is provided with stabilizing devices, install the stabilizers before mounting or servicing the unit in the rack.

## 2-5 Rack Mounting Instructions

This section provides information on installing the chassis into a rack unit with the rails provided. There are a variety of rack units on the market, which may mean that the assembly procedure will differ slightly from the instructions provided. You should also refer to the installation instructions that came with the rack unit you are using. Note: This rail will fit a rack between 26.5" and 36.4" deep

### Identifying the Sections of the Rack Rails

The chassis package includes a rack rail assembly in the rack mounting kit. Each assembly consists of three sections: An inner chassis rail which secures directly to the chassis, an outer rail that secures to the rack, and a middle rail which extends from the outer rail. These assemblies are specifically designed for the left and right side of the chassis.

Figure 2-1. Identifying the Different Rail Sections

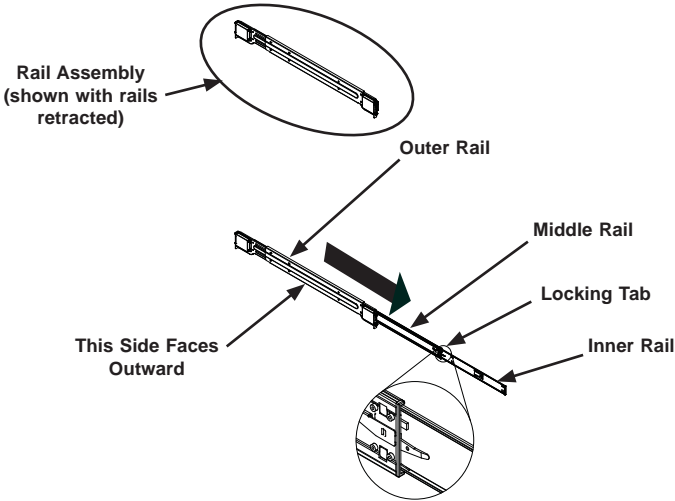

## Locking Tabs

Each inner rail has a locking tab. This tab locks the chassis into place when installed and pushed fully into the rack. These tabs also lock the chassis in place when fully extended from the rack. This prevents the server from coming completely out of the rack when the chassis is pulled out for servicing.

## Releasing the Inner Rail

### *Releasing Inner Rail from the Outer Rails*

1. Identify the left and right outer rail assemblies as described on page 2-4.
2. Pull the inner rail out of the outer rail until it is fully extended as illustrated below.
3. Press the locking tab down to release the inner rail.
4. Pull the inner rail all the way out.
5. Repeat steps 1-3 for the second outer rail.

**Figure 2-2. Extending and Releasing the Inner Rail**

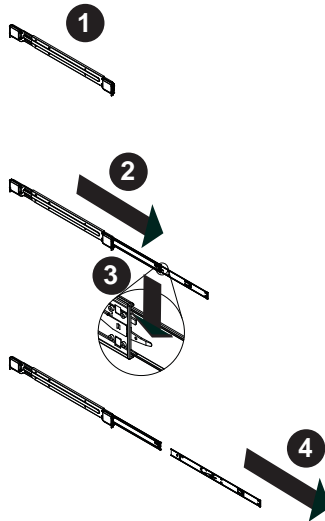

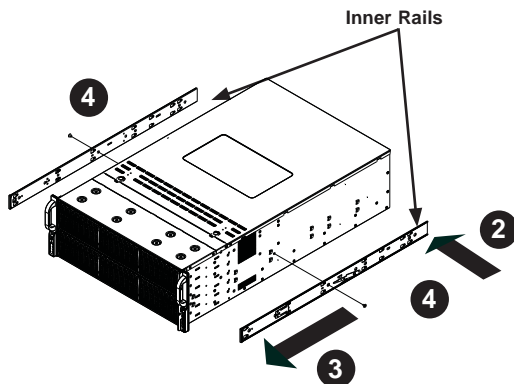

Figure 2-3. Installing the Inner Rails

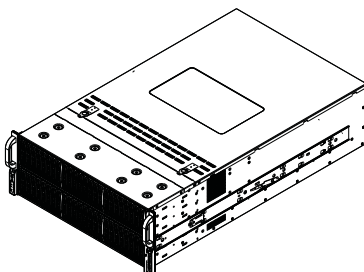

Figure 2-4. Inner Rails Installed on the Chassis

## Installing The Inner Rails on the Chassis

### *Installing the Inner Rails*

1. Confirm that the left and right inner rails have been correctly identified.
2. Place the inner rail firmly against the side of the chassis, aligning the hooks on the side of the chassis with the holes in the inner rail.
3. Slide the inner rail forward toward the front of the chassis until the rail clicks into the locked position, which secures the inner rail to the chassis.
4. Secure the inner rail to the chassis with the screws provided.
5. Repeat steps 1 through 4 above for the other inner rail.



Warning: do not pick up the server by the front handles. They are designed to pull the system from a rack only.

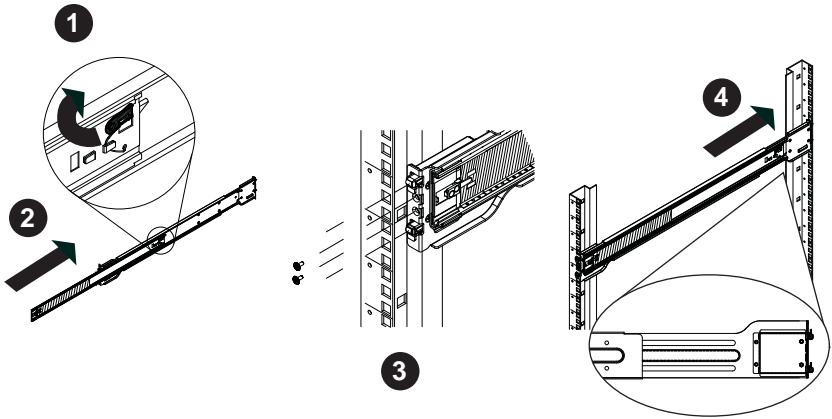

Figure 2-5. Extending and Releasing the Outer Rails

## Installing the Outer Rails on the Rack

### *Installing the Outer Rails*

1. Press upward on the locking tab at the rear end of the middle rail.
2. Push the middle rail back into the outer rail.
3. Hang the hooks of the front of the outer rail onto the slots on the front of the rack. If necessary, use screws to secure the outer rails to the rack, as illustrated above.
4. Pull out the rear of the outer rail, adjusting the length until it fits within the posts of the rack.
5. Hang the hooks of the rear portion of the outer rail onto the slots on the rear of the rack. If necessary, use screws to secure the rear of the outer rail to the rear of the rack.
6. Repeat steps 1-5 for the remaining outer rail.

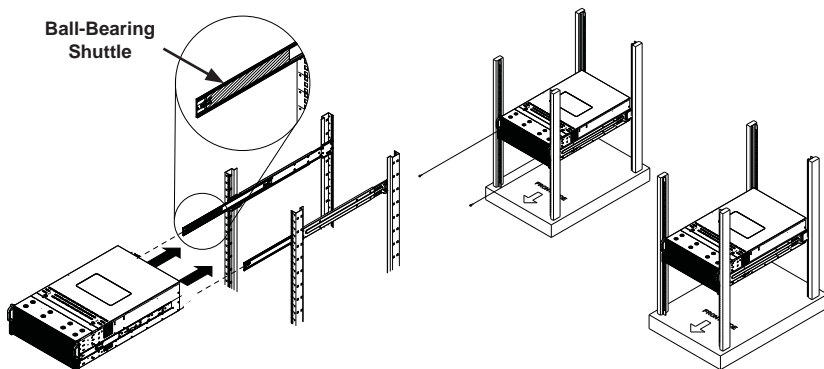

Figure 5-6: Installing into a Rack

**Note:** figures are for illustrative purposes only. Always install servers into racks from the bottom up.

## Standard Chassis Installation

### *Installing the Chassis into a Rack*

1. Confirm that the inner rails are properly installed on the chassis.
2. Confirm that the outer rails are correctly installed on the rack.
3. Pull the middle rail out from the front of the outer rail and make sure that the ball-bearing shuttle is at the front locking position of the middle rail.
4. Align the chassis inner rails with the front of the middle rails.
5. Slide the inner rails on the chassis into the middle rails, keeping the pressure even on both sides, until the locking tab of the inner rail clicks into the front of the middle rail, locking the chassis into the fully extended position.
6. Depress the locking tabs of both sides at the same time and push the chassis all the way into the rear of the rack.
7. If necessary for security purposes, use screws to secure the chassis handles to the front of the rack.



Stability hazard. The rack stabilizing mechanism must be in place, or the rack must be bolted to the floor before you slide the unit out for servicing. Failure to stabilize the rack can cause the rack to tip over.

## Optional Quick Installation Method

The following quick installation method may be used to install the chassis onto a rack.

### *Installing the Chassis into a Rack*

1. Install the whole rail assembly onto the rack as described on page 2-7.
2. Release the inner rail without retracting the middle rail.
3. Install the inner rails on the chassis as previously described on page 2-6.
4. Install the chassis onto the middle rail as described in the previous section.

## Notes

## Chapter 3

# System Interface

### 3-1 Overview

There are several LEDs on the control panel as well as others on the drive carriers to keep you constantly informed of the overall status of the system as well as the activity and health of specific components.

The SC418GTS has two buttons on the chassis control panel: a reset button and a power on/off switch. This chapter explains the meanings of all LED indicators and the appropriate responses you may need to take.

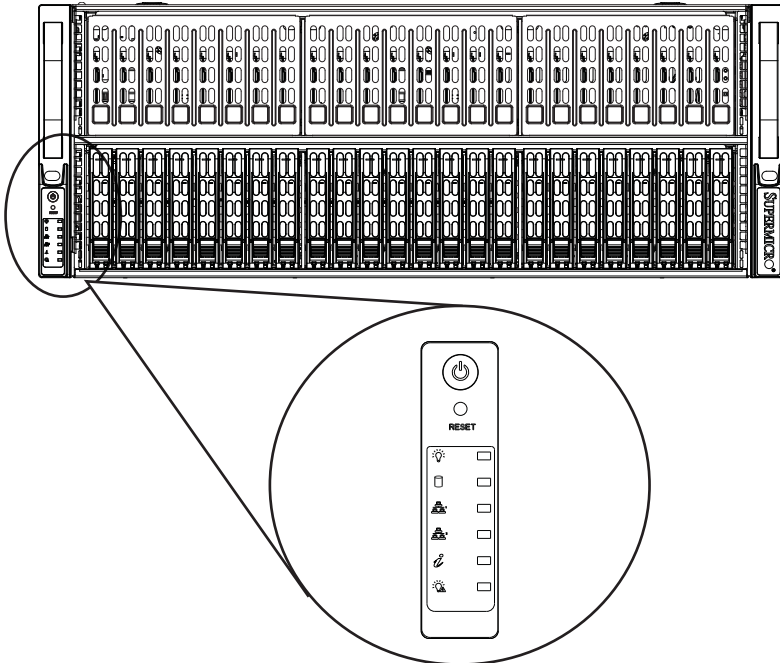

Figure 3-1: Front LED Panel

## 3-2 Control Panel Buttons

There are two push-buttons located on the left handle of the chassis. These are (in order from top to bottom) a power on/off button and a reset button.



### Power

The main power button is used to apply or remove power from the power supply to the server system. Turning off system power with this button removes the main power but keeps standby power supplied to the system. Therefore, you must unplug system before servicing.

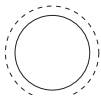

### Reset

The reset button is used to reboot the system.

## 3-3 Control Panel LEDs

The control panel located on the left handle of the SC418GTS chassis has five LEDs. These LEDs provide you with critical information related to different parts of the system. This section explains what each LED indicates when illuminated and any corrective action you may need to take.



### Power

Indicates power is being supplied to the system's power supply units. This LED should normally be illuminated when the system is operating.



### HDD

Indicates IDE channel activity. SAS/SATA drive, and/or DVD-ROM drive activity when flashing.



### NIC1

Indicates network activity on GLAN1 when flashing.



### NIC2

Indicates network activity on GLAN2 when flashing.



### Information LED

This LED will be solid blue when the UID function has been activated. When this LED flashes red, it indicates a fan failure. When red continuously it indicates an overheat condition, which may be caused by cables obstructing the airflow in the system or the ambient room temperature being too warm. Check the routing of the cables and make sure all fans are present and operating normally. You should also check to make sure that the chassis covers are installed. Finally, verify that the heatsinks are installed properly (see Chapter 5). This LED will remain flashing or on as long as the indicated condition exists.

Information LED States	
State	Indication
Continuously On (Red)	An overheat condition has occurred.
Fast Blinking Red (1 Hz)	Fan Failure
Slow Blinking Red (.25 Hz)	Power Fail
Solid Blue	Local UID button has been activated.
Blinking Blue	IPMI/Remote UID has been activated

**Note:** deactivating the UID LED must be performed in the same way it was activated. (If the UID LED was activated via IPMI, you can only turn the LED off via IPMI and not with the UID button.)



## Power Failure

When this LED flashes, it indicates a failure in the redundant power supply.

## 3-4 Drive Carrier LEDs

Your system supports SAS/SATA drives.

### SAS/SATA Drives

Each SAS/SATA drive carrier has two LEDs.

- **Blue:**

Solid on = Drive is present and available.

Blinking = Drive is actively being accessed.

Each Serial ATA drive carrier has a blue LED. When illuminated in a solid on state, this blue LED (on the front of the SAS/SATA drive carrier) indicates drive activity. A connection to the SAS/SATA backplane enables this LED to blink on and off when that particular drive is being accessed.

- **Red:**

Solid on = Drive failure

Blinking = Rebuilding RAID

The red LED to indicate an SAS/SATA drive failure. If one of the SAS/SATA drives fail, you should be notified by your system management software.

## Chapter 4

# Standardized Warning Statements for AC Systems

### 4-1 About Standardized Warning Statements

The following statements are industry standard warnings, provided to warn the user of situations which have the potential for bodily injury. Should you have questions or experience difficulty, contact Supermicro's Technical Support department for assistance. Only certified technicians should attempt to install or configure components.

Read this appendix in its entirety before installing or configuring components in the Supermicro chassis.

These warnings may also be found on our web site at [http://www.supermicro.com/about/policies/safety\\_information.cfm](http://www.supermicro.com/about/policies/safety_information.cfm).

#### Warning Definition



#### Warning!

This warning symbol means danger. You are in a situation that could cause bodily injury. Before you work on any equipment, be aware of the hazards involved with electrical circuitry and be familiar with standard practices for preventing accidents.

#### 警告の定義

この警告サインは危険を意味します。

人身事故につながる可能性がありますので、いずれの機器でも動作させる前に、電気回路に含まれる危険性に注意して、標準的な事故防止策に精通して下さい。

此警告符号代表危險。

您正處於可能受到嚴重傷害的工作環境中。在您使用設備開始工作之前，必須充分意識到觸電的危險，並熟練掌握防止事故發生的標準工作程序。請根據每項警告結尾的聲明號碼找到此設備的安全性警告說明的翻譯文本。

此警告符號代表危險。

您正處於可能身體可能會受損傷的工作環境中。在您使用任何設備之前，請注意觸電的危險，並且要熟悉預防事故發生的標準工作程序。請依照每一注意事項後的號碼找到相關的翻譯說明內容。

## Warnung

### WICHTIGE SICHERHEITSHINWEISE

Dieses Warnsymbol bedeutet Gefahr. Sie befinden sich in einer Situation, die zu Verletzungen führen kann. Machen Sie sich vor der Arbeit mit Geräten mit den Gefahren elektrischer Schaltungen und den üblichen Verfahren zur Vorbeugung vor Unfällen vertraut. Suchen Sie mit der am Ende jeder Warnung angegebenen Anweisungsnummer nach der jeweiligen Übersetzung in den übersetzten Sicherheitshinweisen, die zusammen mit diesem Gerät ausgeliefert wurden.

BEWAHREN SIE DIESE HINWEISE GUT AUF.

### INSTRUCCIONES IMPORTANTES DE SEGURIDAD

Este símbolo de aviso indica peligro. Existe riesgo para su integridad física. Antes de manipular cualquier equipo, considere los riesgos de la corriente eléctrica y familiarícese con los procedimientos estándar de prevención de accidentes. Al final de cada advertencia encontrará el número que le ayudará a encontrar el texto traducido en el apartado de traducciones que acompaña a este dispositivo.

GUARDE ESTAS INSTRUCCIONES.

### IMPORTANTES INFORMATIONS DE SÉCURITÉ

Ce symbole d'avertissement indique un danger. Vous vous trouvez dans une situation pouvant entraîner des blessures ou des dommages corporels. Avant de travailler sur un équipement, soyez conscient des dangers liés aux circuits électriques et familiarisez-vous avec les procédures couramment utilisées pour éviter les accidents. Pour prendre connaissance des traductions des avertissements figurant dans les consignes de sécurité traduites qui accompagnent cet appareil, référez-vous au numéro de l'instruction situé à la fin de chaque avertissement.

CONSERVEZ CES INFORMATIONS.

## **תקנת הצהרות אזהרה**

הצהרות הבאות הן אזהרות על פי תקני התעשייה, על מנת להזהיר את המשתמש מפני חבלה פיזית אפשרית. במידה ויש שאלות או היתקלות בבעיה כלשהי, יש ליצור קשר עם מחלקת תמיכה טכנית של סופרמיקרו. טכנאים מוסמכים בלבד רשאים להתקין או להגדיר את הרכיבים.

יש לקרוא את הנספח במלואו לפני התקנת או הגדרת הרכיבים במארוי סופרמיקרו.

تحذير! هذا الرمز يعني خطر انك في حالة يمكن أن تتسبب في اصابة جسدية .  
قبل أن تعمل على أي معدات، كن على علم بالمخاطر الناجمة عن الدوائر  
الكهربائية  
وكن على دراية بالممارسات الوقائية لمنع وقوع أي حوادث  
استخدم رقم البيان المنصوص في نهاية كل تحذير للعثور ترجمتها

안전을 위한 주의사항

경고!

이 경고 기호는 위험이 있음을 알려 줍니다. 작업자의 신체에 부상을 야기 할 수 있는 상태에 있게 됩니다. 모든 장비에 대한 작업을 수행하기 전에 전기회로와 관련된 위험요소들을 확인하시고 사전에 사고를 방지할 수 있도록 표준 작업절차를 준수해 주시기 바랍니다.

해당 번역문을 찾기 위해 각 경고의 마지막 부분에 제공된 경고문 번호를 참조하십시오

#### BELANGRIJKE VEILIGHEIDSINSTRUCTIES

Dit waarschuwings symbool betekent gevaar. U verkeert in een situatie die lichamelijk letsel kan veroorzaken. Voordat u aan enige apparatuur gaat werken, dient u zich bewust te zijn van de bij een elektrische installatie betrokken risico's en dient u op de hoogte te zijn van de standaard procedures om ongelukken te voorkomen. Gebruik de nummers aan het eind van elke waarschuwing om deze te herleiden naar de desbetreffende locatie.

BEWAAR DEZE INSTRUCTIES

## Installation Instructions



### Warning!

Read the installation instructions before connecting the system to the power source.

設置手順書

システムを電源に接続する前に、設置手順書をお読み下さい。

警告

将此系统连接电源前，请先阅读安装说明。

警告

將系統與電源連接前，請先閱讀安裝說明。

Warnung

Vor dem Anschließen des Systems an die Stromquelle die Installationsanweisungen lesen.

¡Advertencia!

Lea las instrucciones de instalación antes de conectar el sistema a la red de alimentación.

Attention

Avant de brancher le système sur la source d'alimentation, consulter les directives d'installation.

יש לקרוא את הוראות התקנה לפני חיבור המערכת למקור מתח.

اقرأ إرشادات التركيب قبل توصيل النظام إلى مصدر للطاقة

시스템을 전원에 연결하기 전에 설치 안내를 읽어주시시오.

Waarschuwing

Raadpleeg de installatie-instructies voordat u het systeem op de voedingsbron aansluit.

## Circuit Breaker



### Warning!

This product relies on the building's installation for short-circuit (overcurrent) protection. Ensure that the protective device is rated not greater than: 250 V, 20 A.

サーキット・ブレーカー

この製品は、短絡(過電流)保護装置がある建物での設置を前提としています。

保護装置の定格が250 V、20 Aを超えないことを確認下さい。

### 警告

此产品的短路(过载电流)保护由建筑物的供电系统提供,确保短路保护设备的额定电流不大于250V,20A。

### 警告

此产品的短路(过载电流)保护由建筑物的供电系统提供,确保短路保护设备的额定电流不大于250V,20A。

### Warnung

Dieses Produkt ist darauf angewiesen, dass im Gebäude ein Kurzschluss- bzw. Überstromschutz installiert ist. Stellen Sie sicher, dass der Nennwert der Schutzvorrichtung nicht mehr als: 250 V, 20 A beträgt.

### ¡Advertencia!

Este equipo utiliza el sistema de protección contra cortocircuitos (o sobrecorrientes) del edificio. Asegúrese de que el dispositivo de protección no sea superior a: 250 V, 20 A.

### Attention

Pour ce qui est de la protection contre les courts-circuits (surtension), ce produit dépend de l'installation électrique du local. Vérifiez que le courant nominal du dispositif de protection n'est pas supérieur à :250 V, 20 A.

מוצר זה מסתמך על הגנה המותקנת במבנים למניעת קצר חשמלי. יש לוודא  
המכשיר המגן מפני הקצר החשמלי הוא לא יותר מ-20A, 60VDC

هذا المنتج يعتمد على معدات الحماية من الدوائر القصيرة التي تم تثبيتها في  
المبنى

تأكد من أن تقيّم الجاهز الوقائي ليس أكثر من: 20A, 250VDC

경고!

이 제품은 전원의 단락(과전류)방지에 대해서 전적으로 건물의 관련 설비에 의존합니다. 보호장치의 정격이 반드시 250V(볼트), 20A(암페어)를 초과하지 않도록 해야 합니다.

Waarschuwing

Dit product is afhankelijk van de kortsluitbeveiliging (overspanning) van uw elektrische installatie. Controleer of het beveiligde apparaat niet groter gedimensioneerd is dan 220V, 20A.

## Power Disconnection Warning



### Warning!

The system must be disconnected from all sources of power and the power cord removed from the power supply module(s) before accessing the chassis interior to install or remove system components.

### 電源切斷の警告

システムコンポーネントの取り付けまたは取り外しのために、シャーシ内部にアクセスするには、

システムの電源はすべてのソースから切斷され、電源コードは電源モジュールから取り外す必要があります。

警告

在你打开机箱并安装或移除内部器件前，必须将系统完全断电，并移除电源线。

警告

在您打開機殼安裝或移除內部元件前，必須將系統完全斷電，並移除電源線。

Warnung

Das System muss von allen Quellen der Energie und vom Netzanschlusskabel getrennt sein, das von den Spg.Versorgungsteilmodulen entfernt wird, bevor es auf den Chassisinnenraum zurückgreift, um Systemsbestandteile anzubringen oder zu entfernen.

¡Advertencia!

El sistema debe ser disconnected de todas las fuentes de energía y del cable eléctrico quitado de los módulos de fuente de alimentación antes de tener acceso el interior del chasis para instalar o para quitar componentes de sistema.

Attention

Le système doit être débranché de toutes les sources de puissance ainsi que de son cordon d'alimentation secteur avant d'accéder à l'intérieur du châssis pour installer ou enlever des composants de système.

**אזהרה!**

יש לנתק את המערכת מכל מקורות החשמל ויש להסיר את כבל החשמלי מהספק לפני גישה לחלק הפנימי של המארז לצורך התקנת או הסרת רכיבים.

يجب فصل النظام من جميع مصادر الطاقة وإزالة سلك الكهرباء من وحدة امداد الطاقة قبل الوصول إلى المناطق الداخلية للهيكल لتثبيت أو إزالة مكونات الجهاز

경고!

시스템에 부품들을 장착하거나 제거하기 위해서는 새시 내부에 접근하기 전에 반드시 전원 공급장치로부터 연결되어있는 모든 전원과 전기코드를 분리해주어야 합니다.

Waarschuwing

Voordat u toegang neemt tot het binnenwerk van de behuizing voor het installeren of verwijderen van systeem onderdelen, dient u alle spanningsbronnen en alle stroomkabels aangesloten op de voeding(en) van de behuizing te verwijderen

## Equipment Installation



### Warning!

Only trained and qualified personnel should be allowed to install, replace, or service this equipment.

### 機器の設置

トレーニングを受け認定された人だけがこの装置の設置、交換、またはサービスを許可されています。

### 警告

只有经过培训且具有资格的人员才能进行此设备的安装、更换和维修。

### 警告

只有經過受訓且具資格人員才可安裝、更換與維修此設備。

### Warnung

Das Installieren, Ersetzen oder Bedienen dieser Ausrüstung sollte nur geschultem, qualifiziertem Personal gestattet werden.

### ¡Advertencia!

Solamente el personal calificado debe instalar, reemplazar o utilizar este equipo.

### Attention

Il est vivement recommandé de confier l'installation, le remplacement et la maintenance de ces équipements à des personnels qualifiés et expérimentés.

### אזהרה!

צוות מוסמך בלבד רשאי להתקין, להחליף את הציוד או לתת שירות עבור הציוד.

يجب أن يسمح فقط للموظفين المؤهلين والمدربين لتكريب واستبدال أو خدمة هذا الجهاز

### 경고!

훈련을 받고 공인된 기술자만이 이 장비의 설치, 교체 또는 서비스를 수행할 수 있습니다.

## Waarschuwing

Deze apparatuur mag alleen worden geïnstalleerd, vervangen of hersteld door geschoold en gekwalificeerd personeel.

## Restricted Area



### Warning!

This unit is intended for installation in restricted access areas. A restricted access area can be accessed only through the use of a special tool, lock and key, or other means of security. (This warning does not apply to workstations).

## アクセス制限区域

このユニットは、アクセス制限区域に設置されることを想定しています。

アクセス制限区域は、特別なツール、鍵と錠前、その他のセキュリティの手段を用いてのみ出入りが可能です。

## 警告

此部件应安装在限制进出的场所，限制进出的场所指只能通过使用特殊工具、锁和钥匙或其它安全手段进出的场所。

## 警告

此裝置僅限安裝於進出管制區域，進出管制區域係指僅能以特殊工具、鎖頭及鑰匙或其他安全方式才能進入的區域。

## Warnung

Diese Einheit ist zur Installation in Bereichen mit beschränktem Zutritt vorgesehen. Der Zutritt zu derartigen Bereichen ist nur mit einem Spezialwerkzeug, Schloss und Schlüssel oder einer sonstigen Sicherheitsvorkehrung möglich.

## ¡Advertencia!

Esta unidad ha sido diseñada para instalación en áreas de acceso restringido. Sólo puede obtenerse acceso a una de estas áreas mediante la utilización de una herramienta especial, cerradura con llave u otro medio de seguridad.

## Attention

Cet appareil doit être installée dans des zones d'accès réservés. L'accès à une zone d'accès réservé n'est possible qu'en utilisant un outil spécial, un mécanisme de verrouillage et une clé, ou tout autre moyen de sécurité.

## אזור עם גישה מוגבלת

### אזהרה!

יש להתקין את היחידה באזורים שיש בהם הגבלת גישה. הגישה ניתנת בעזרת כלי אבטחה בלבד (מפתח, מנעול וכד').

تم تخصيص هذه الوحدة لت تركيبها في مناطق محظورة .  
يمكن الوصول إلى منطقة محظورة فقط من خلال استخدام أداة خاصة،  
قفل ومفتاح أو أي وسيلة أخرى للأمان

경고!

이 장치는 접근이 제한된 구역에 설치하도록 되어 있습니다. 특수도구, 잠금 장치 및 키, 또는 기타 보안 수단을 통해서만 접근 제한 구역에 들어갈 수 있습니다.

Waarschuwing

Dit apparaat is bedoeld voor installatie in gebieden met een beperkte toegang. Toegang tot dergelijke gebieden kunnen alleen verkregen worden door gebruik te maken van speciaal gereedschap, slot en sleutel of andere veiligheidsmaatregelen.

## Battery Handling



### Warning!

There is the danger of explosion if the battery is replaced incorrectly. Replace the battery only with the same or equivalent type recommended by the manufacturer. Dispose of used batteries according to the manufacturer's instructions

電池の取り扱い

電池交換が正しく行われなかった場合、破裂の危険性があります。交換する電池はメーカーが推奨する型、または同等のものを使用下さい。使用済電池は製造元の指示に従って処分して下さい。

警告

電池更換不當會有爆炸危險。請只使用同類電池或製造商推薦的功能相當的電池更換原有電池。請按製造商的說明處理廢舊電池。

警告

電池更換不當會有爆炸危險。請使用製造商建議之相同或功能相當的電池更換原有電池。請按照製造商的說明指示處理廢棄舊電池。

### Warnung

Bei Einsetzen einer falschen Batterie besteht Explosionsgefahr. Ersetzen Sie die Batterie nur durch den gleichen oder vom Hersteller empfohlenen Batterietyp. Entsorgen Sie die benutzten Batterien nach den Anweisungen des Herstellers.

### Attention

Danger d'explosion si la pile n'est pas remplacée correctement. Ne la remplacer que par une pile de type semblable ou équivalent, recommandée par le fabricant. Jeter les piles usagées conformément aux instructions du fabricant.

### ¡Advertencia!

Existe peligro de explosión si la batería se reemplaza de manera incorrecta. Reemplazar la batería exclusivamente con el mismo tipo o el equivalente recomendado por el fabricante. Desechar las baterías gastadas según las instrucciones del fabricante.

### אזהרה!

קיימת סכנת פיצוץ של הסוללה במידה והוחלפה בדרך לא תקינה. יש להחליף את הסוללה בסוג התואם מחברת יצרן מומלצת.

סילוק הסוללות המשומשות יש לבצע לפי הוראות היצרן.

هناك خطر من انفجار في حالة استبدال البطارية بطريقة غير صحيحة فعليك استبدال البطارية فقط بنفس النوع أو ما يعادلها كما أوصت به الشركة المصنعة تخلص من البطاريات المستعملة وفقا لتعليمات الشركة الصانعة

### 경고!

배터리가 올바르게 교체되지 않으면 폭발의 위험이 있습니다. 기존 배터리와 동일하거나 제조사에서 권장하는 동등한 종류의 배터리로만 교체해야 합니다. 제조사의 안내에 따라 사용된 배터리를 처리하여 주십시오.

### Waarschuwing

Er is ontploffingsgevaar indien de batterij verkeerd vervangen wordt. Vervang de batterij slechts met hetzelfde of een equivalent type die door de fabrikant aanbevolen wordt. Gebruikte batterijen dienen overeenkomstig fabrieksvoorschriften afgevoerd te worden.

## Redundant Power Supplies



### Warning!

This unit might have more than one power supply connection. All connections must be removed to de-energize the unit.

#### 冗長電源装置

このユニットは複数の電源装置が接続されている場合があります。  
ユニットの電源を切るためには、すべての接続を取り外さなければなりません。

#### 警告

此部件连接的电源可能不止一个，必须将所有电源断开才能停止给该部件供电。

#### 警告

此装置连接的电源可能不只一个，必须切断所有电源才能停止对该装置的供电。

#### Warnung

Dieses Gerät kann mehr als eine Stromzufuhr haben. Um sicherzustellen, dass der Einheit kein Strom zugeführt wird, müssen alle Verbindungen entfernt werden.

#### ¡Advertencia!

Puede que esta unidad tenga más de una conexión para fuentes de alimentación. Para cortar por completo el suministro de energía, deben desconectarse todas las conexiones.

#### Attention

Cette unité peut avoir plus d'une connexion d'alimentation. Pour supprimer toute tension et tout courant électrique de l'unité, toutes les connexions d'alimentation doivent être débranchées.

**אם קיים יותר מספק אחד**

**אזהרה!**

ליחידה יש יותר מחיבור אחד של ספק. יש להסיר את כל החיבורים על מנת לרוקן את היחידה.

قد يكون لهذا الجهاز عدة اتصالات بوحدات امداد الطاقة.  
يجب إزالة كافة الاتصالات لعزل الوحدة عن الكهرباء

경고!

이 장치에는 한 개 이상의 전원 공급 단자가 연결되어 있을 수 있습니다. 이 장치에 전원을 차단하기 위해서는 모든 연결 단자를 제거해야만 합니다.

Waarschuwing

Deze eenheid kan meer dan één stroomtoevoeraansluiting bevatten. Alle aansluitingen dienen verwijderd te worden om het apparaat stroomloos te maken.

### Backplane Voltage



**Warning!**

Hazardous voltage or energy is present on the backplane when the system is operating. Use caution when servicing.

バックプレーンの電圧

システムの稼働中は危険な電圧または電力が、バックプレーン上にかかっています。

修理する際にはご注意ください。

警告

当系統正在进行时，背板上有很危险的电压或能量，进行维修时务必小心。

警告

當系統正在進行時，背板上有危險的電壓或能量，進行維修時務必小心。

Warnung

Wenn das System in Betrieb ist, treten auf der Rückwandplatine gefährliche Spannungen oder Energien auf. Vorsicht bei der Wartung.

¡Advertencia!

Cuando el sistema está en funcionamiento, el voltaje del plano trasero es peligroso. Tenga cuidado cuando lo revise.

Attention

Lorsque le système est en fonctionnement, des tensions électriques circulent sur le fond de panier. Prendre des précautions lors de la maintenance.

## מתח בפנל האחורי

אזהרה!  
קיימת סכנת מתח בפנל האחורי בזמן תפעול המערכת. יש להיזהר במהלך  
העבודה.

هناك خطر من التيار الكهربائي أو الطاقة الموجودة على اللوحة  
عندما يكون النظام يعمل كن حذرا عند خدمة هذا الجهاز

경고!

시스템이 동작 중일 때 후면판 (Backplane)에는 위험한 전압이나 에너지가 발생  
합니다. 서비스 작업 시 주의하십시오.

Waarschuwing

Een gevaarlijke spanning of energie is aanwezig op de backplane wanneer het  
systeem in gebruik is. Voorzichtigheid is geboden tijdens het onderhoud.

## Comply with Local and National Electrical Codes



### Warning!

Installation of the equipment must comply with local and national electrical codes.

地方および国の電気規格に準拠

機器の取り付けはその地方および国の電気規格に準拠する必要があります。

警告

设备安装必须符合本地与本国电气法规。

警告

設備安裝必須符合本地與本國電氣法規。

Warnung

Die Installation der Geräte muss den Sicherheitsstandards entsprechen.

¡Advertencia!

La instalación del equipo debe cumplir con las normas de electricidad locales y  
nacionales.

Attention

L'équipement doit être installé conformément aux normes électriques nationales et locales.

**תיאום חוקי החשמל הארצי**

**אזהרה!**

התקנת הציוד חייבת להיות תואמת לחוקי החשמל המקומיים והארציים.

تركيب المعدات الكهربائية يجب أن يمتثل للقوانين المحلية والوطنية المتعلقة بالكهرباء

경고!

현 지역 및 국가의 전기 규정에 따라 장비를 설치해야 합니다.

Waarschuwing

Bij installatie van de apparatuur moet worden voldaan aan de lokale en nationale elektriciteitsvoorschriften.

**Product Disposal**



**Warning!**

Ultimate disposal of this product should be handled according to all national laws and regulations.

**製品の廃棄**

この製品を廃棄処分する場合、国の関係する全ての法律・条例に従い処理する必要があります。

**警告**

本製品の废弃処理应根据所有国家的法律和规章进行。

**警告**

本產品的廢棄處理應根據所有國家的法律和規章進行。

**Warnung**

Die Entsorgung dieses Produkts sollte gemäß allen Bestimmungen und Gesetzen des Landes erfolgen.

¡Advertencia!

Al deshacerse por completo de este producto debe seguir todas las leyes y reglamentos nacionales.

Attention

La mise au rebut ou le recyclage de ce produit sont généralement soumis à des lois et/ou directives de respect de l'environnement. Renseignez-vous auprès de l'organisme compétent.

## סילוק המוצר

אזהרה!

סילוק סופי של מוצר זה חייב להיות בהתאם להנחיות וחוקי המדינה.

عند التخلص النهائي من هذا المنتج ينبغي التعامل معه وفقا لجميع القوانين واللوائح الوطنية

경고!

이 제품은 해당 국가의 관련 법규 및 규정에 따라 폐기되어야 합니다.

Waarschuwing

De uiteindelijke verwijdering van dit product dient te geschieden in overeenstemming met alle nationale wetten en reglementen.

## Hot Swap Fan Warning



### Warning!

The fans might still be turning when you remove the fan assembly from the chassis. Keep fingers, screwdrivers, and other objects away from the openings in the fan assembly's housing.

ファン・ホットスワップの警告

シャーシから冷却ファン装置を取り外した際、ファンがまだ回転している可能性があります。ファンの開口部に、指、ドライバー、およびその他のものを近づけないで下さい。

警告

当您从机架移除风扇装置，风扇可能仍在转动。小心不要将手指、螺丝起子和其他物品太靠近风扇

**警告**

當您從機架移除風扇裝置，風扇可能仍在轉動。小心不要將手指、螺絲起子和其他物品太靠近風扇。

**Warnung**

Die Lüfter drehen sich u. U. noch, wenn die Lüfterbaugruppe aus dem Chassis genommen wird. Halten Sie Finger, Schraubendreher und andere Gegenstände von den Öffnungen des Lüftergehäuses entfernt.

**¡Advertencia!**

Los ventiladores podran dar vuelta cuando usted quite el montaje del ventilador del chasis. Mantenga los dedos, los destornilladores y todos los objetos lejos de las aberturas del ventilador

**Attention**

Il est possible que les ventilateurs soient toujours en rotation lorsque vous retirez le bloc ventilateur du châssis. Prenez garde à ce que doigts, tournevis et autres objets soient éloignés du logement du bloc ventilateur.

**אזהרה!**

כאשר מסירים את חלקי המאוורר מהמארז, יתכן והמאווררים עדיין עובדים. יש להרחיק למרחק בטוח את האצבעות וכלי עבודה שונים מהפתחים בתוך המאוורר

من الممكن أن تترال المراوح لا تدور عند إزالة كتلة المروحة من الهيكل يجب إبقاء الأصابع ومفكات البراغي وغيرها من الأشياء بعيدا عن الفتحات في كتلة المروحة.

**경고!**

새시로부터 팬 조립품을 제거할 때 팬은 여전히 회전하고 있을 수 있습니다. 팬 조립품 외관의 열려있는 부분들로부터 손가락 및 스크류드라이버, 다른 물체들이 가까이 하지 않도록 배치해 주십시오.

**Waarschuwing**

Het is mogelijk dat de ventilator nog draait tijdens het verwijderen van het ventilatorsamenstel uit het chassis. Houd uw vingers, schroevendraaiers en eventuele andere voorwerpen uit de buurt van de openingen in de ventilatorbehuizing.

## Power Cable and AC Adapter



### Warning!

When installing the product, use the provided or designated connection cables, power cables and AC adaptors. Using any other cables and adaptors could cause a malfunction or a fire. Electrical Appliance and Material Safety Law prohibits the use of UL or CSA -certified cables (that have UL/CSA shown on the code) for any other electrical devices than products designated by Supermicro only.

### 電源コードとACアダプター

製品を設置する場合、提供または指定された接続ケーブル、電源コードとACアダプターを使用下さい。他のケーブルやアダプタを使用すると故障や火災の原因になることがあります。電気用品安全法は、ULまたはCSA認定のケーブル(UL/CSEマークがコードに表記)をSupermicroが指定する製品以外に使用することを禁止しています。

### 警告

安装此产品时,请使用本身提供的或指定的连接线,电源线和电源适配器.使用其它线材或适配器可能会引起故障或火灾.除了Supermicro所指定的产品,电气用品和材料安全法律规定禁止使用未经UL或CSA认证的线材。(线材上会显示UL/CSA符号)。

### 警告

安装此產品時,請使用本身提供的或指定的連接線,電源線和電源適配器.使用其它線材或適配器可能會引起故障或火災.除了Supermicro所指定的產品,電氣用品和材料安全法律規定禁止使用未經UL或CSA認證的線材。(線材上會顯示UL/CSA符號)。

### Warnung

Bei der Installation des Produkts, die zur Verfügung gestellten oder benannt Anschlusskabel, Stromkabel und Netzteile. Verwendung anderer Kabel und Adapter kann zu einer Fehlfunktion oder ein Brand entstehen. Elektrische Geräte und Material Safety Law verbietet die Verwendung von UL-oder CSA-zertifizierte Kabel, UL oder CSA auf der Code für alle anderen elektrischen Geräte als Produkte von Supermicro nur bezeichnet gezeigt haben.

### ¡Advertencia!

Al instalar el producto, utilice los cables de conexión previstos o designados, los cables y adaptadores de CA. La utilización de otros cables y adaptadores podría ocasionar un mal funcionamiento o un incendio. Aparatos Eléctricos y la Ley de Seguridad del Material prohíbe el uso de UL o CSA cables certificados que tienen UL o CSA se muestra en el código de otros dispositivos eléctricos que los productos designados por Supermicro solamente.

## Attention

Lors de l'installation du produit, utilisez les bables de connection fournis ou désigné. L'utilisation d'autres cables et adaptateurs peut provoquer un dysfonctionnement ou un incendie. Appareils électroménagers et de loi sur la sécurité Matériel interdit l'utilisation de UL ou CSA cables certifiés qui ont UL ou CSA indiqué sur le code pour tous les autres appareils électriques que les produits désignés par Supermicro seulement.

## חשמליים ומתאמי AC

!אזהרה

כאשר מתקינים את המוצר, יש להשתמש בכבלים, ספקים ומתאמים AC אשר נועדו וסופקו לשם כך. שימוש בכל כבל או מתאם אחר יכול לגרום לתקלה או קצר חשמלי. על פי חוקי שימוש במכשירי חשמל וחוקי בטיחות, קיים איסור להשתמש בכבלים המוסמכים ב- UL או ב- CSA (כשאר מופיע עליהם קוד של UL/CSA) עבור כל מוצר חשמלי אחר שלא צויין על ידי סופרמיקרו בלבד.

عند تركيب الجهاز يجب استخدام كابلات التوصيل، والكابلات الكهربائية ومحولات التيار المتردد التي . أن استخدام أي كابلات ومحولات أخرى يتسبب في حدوث عطل أو حريق. تم توفيرها لك مع المنتج الأجهزة الكهربائية ومواد قانون السلامة يحظر استخدام الكابلات CSA أو UL معتمدة من قبل لأي أجهزة كهربائية أخرى غير المنتجات المعينة من قبل Supermicro (التي تحمل علامة UL/CSA)

경고!

제품을 설치할 때에는 제공되거나 지정된 연결케이블과 전원케이블, AC 어댑터를 사용해야 합니다. 그 밖의 다른 케이블들이나 어댑터들은 고장 또는 화재의 원인이 될 수 있습니다. 전기용품안전법 (Electrical Appliance and Material Safety Law)은 슈퍼마이크로에서 지정한 제품들 외에는 그 밖의 다른 전기 장치들을 위한 UL 또는 CSA에서 인증한 케이블(전선 위에 UL/CSA가 표시)들의 사용을 금지합니다.

## Waarschuwing

Bij het installeren van het product, gebruik de meegeleverde of aangewezen kabels, stroomkabels en adapters. Het gebruik van andere kabels en adapters kan leiden tot een storing of een brand. Elektrisch apparaat en veiligheidsinformatiebladen wet verbiedt het gebruik van UL of CSA gecertificeerde kabels die UL of CSA die op de code voor andere elektrische apparaten dan de producten die door Supermicro alleen.

## Notes

## Chapter 5

### Advanced Serverboard Setup

This chapter covers the steps required to install the X9DRG-OF/OTFserverboard into the chassis, connect the data and power cables and install add-on cards. All serverboard jumpers and connections are also described. A layout and quick reference chart are included in this chapter for your reference. Remember to completely close the chassis when you have finished working with the serverboard to better cool and protect the system.

#### 5-1 Handling the Serverboard

Electrostatic Discharge (ESD) can damage electronic components. To prevent damage to any printed circuit boards (PCBs), it is important to handle them very carefully (see previous chapter). To prevent the serverboard from bending, keep one hand under the center of the board to support it when handling. The following measures are generally sufficient to protect your equipment from electric static discharge.

##### Precautions

- Use a grounded wrist strap designed to prevent Electrostatic Discharge (ESD).
- Touch a grounded metal object before removing any board from its antistatic bag.
- Handle a board by its edges only; do not touch its components, peripheral chips, memory modules or gold contacts.
- When handling chips or modules, avoid touching their pins.
- Put the serverboard, add-on cards and peripherals back into their antistatic bags when not in use.
- For grounding purposes, make sure your computer chassis provides excellent conductivity between the power supply, the case, the mounting fasteners and the serverboard.

##### Unpacking

The serverboard is shipped in antistatic packaging to avoid electrical static discharge. When unpacking the board, make sure the person handling it is static protected.

## 5-2 Connecting Cables

This section covers instructions on how to connect cables to the serverboard.

### Connecting Data Cables

The cables used to transfer data from the peripheral devices have been carefully routed in preconfigured systems to prevent them from blocking the flow of cooling air that moves through the system from front to back. If you need to disconnect any of these cables, you should take care to reroute them as they were originally routed and connected after reconnecting them to the serverboard and peripherals. If you are configuring the system, keep the interior system airflow in mind when routing the cables.

The following cables need to be connected for the SuperServer 4027GR-TR/TRT system:

- Two (2) HDD power extension to backplane cables (CBL-0449L)
- Two (2) cross-over mini SAS HD to 4 SATA w/ SB cables (CBL-SAST-0591)
- Eight (8) 8-pin to two 6+2 pin 12V GPU power cables (CBL-PWEX-0582)
- Eight (8) cooling fan power cables
- Front panel cable
- Chassis intrusion cable

### 5-3 Control Panel Connectors and I/O Ports

The I/O ports are located on the backplane of the serverboard. See Figure 5-2 below for the descriptions of the various I/O ports.

Figure 5-1. Rear I/O Ports

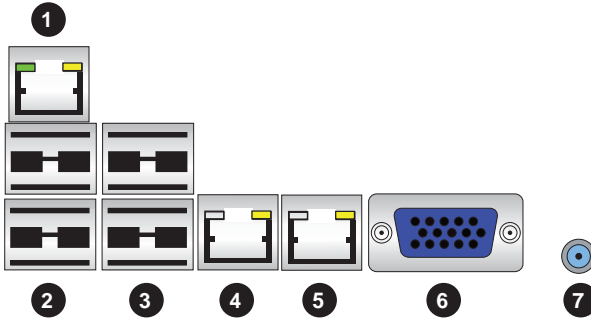

Back Panel I/O Port Locations and Definitions	
1.	Dedicated IPMI LAN
2.	Back Panel USB Port 0/1 (USB2.0)
3.	Back Panel USB Port 2/3 (USB2.0)
4.	LAN1
5.	LAN2
6.	VGA Port
7.	UID Switch

## Connecting the Control Panel

JF1 contains header pins for various front control panel connectors. See Figure 5-2 for the pin locations of the various front control panel buttons and LED indicators. Even and odd numbered pins are on opposite sides of each header.

All JF1 wires have been bundled into single keyed ribbon cable to simplify their connection. The red wire in the ribbon cable plugs into pin 1 of JF1. Connect the other end of the cable to the Control Panel printed circuit board, located just behind the system status LEDs in the chassis.

See the Connector Definitions section in this chapter for details and pin descriptions of JF1.

**Figure 5-2. Front Control Panel Header Pins (JF1)**

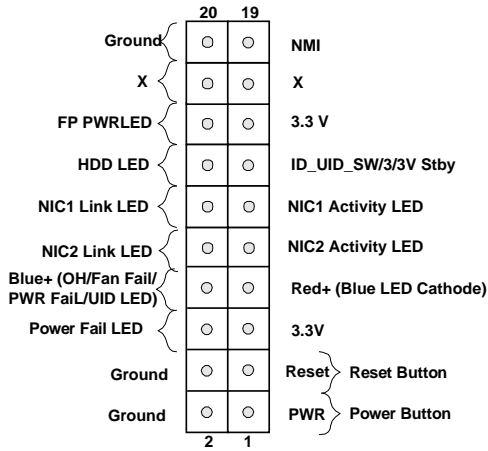

## 5-4 Processor and Heatsink Installation

**Caution!** When handling the processor package, avoid placing direct pressure on the label area. Make sure to install the system board into the chassis before you install the CPU heatsink.

### Notes

- Always connect the power cord last, and always remove it before adding, removing or changing any hardware components. Make sure that you install the processor into the CPU socket before you install the CPU heatsink.
- If you buy a CPU separately, make sure that you use an Intel-certified multi-directional heatsink only.
- When receiving a server board without a processor pre-installed, make sure that the plastic CPU socket cap is in place and none of the socket pins are bent; otherwise, contact your retailer immediately.
- Refer to the Supermicro website for updates on CPU support.
- When one CPU is installed, be sure to installed on CPU Socket 1 first.

### Installing the LGA2011 Processor

1. There are two load levers on the LGA2011 socket. To open the socket cover, first press and release the load lever labeled 'Open 1st'.

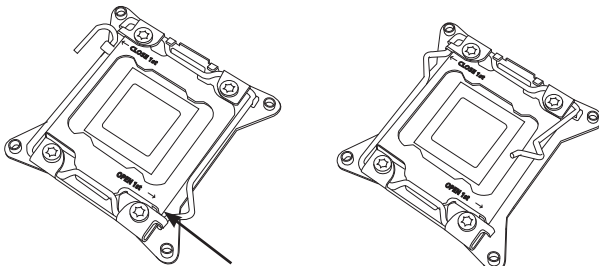

Press down on  
load lever labeled  
'Open 1st'.

2. Press the second load lever labeled 'Close 1st' to release the load plate that covers the CPU socket from its locking position.

**Press down on the load lever labeled 'Close 1st'**

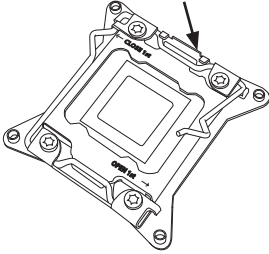

**Pull the lever away from the socket**

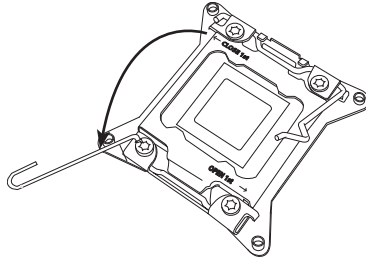

3. With the lever labeled 'Close 1st' fully retracted, gently push down on the lever marked 'Open 1st' to open the load plate. Lift the load plate to open it completely.

**Gently push to pop the load plate open.**

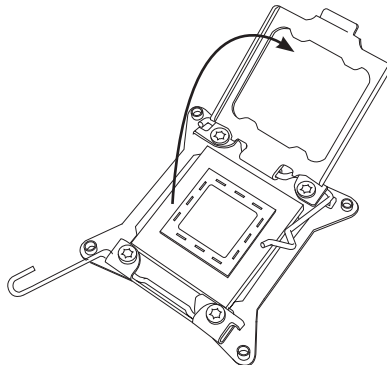
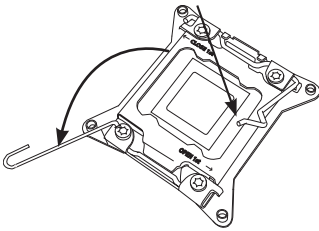

4. Use your index fingers to loosen the lever and open the load plate.

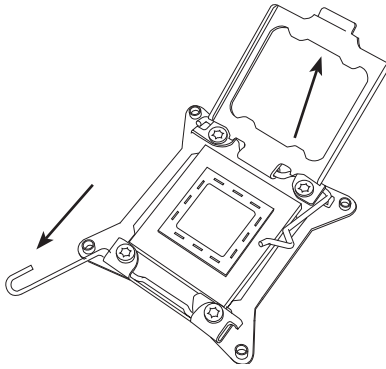

5. Use your thumb and index finger to hold the CPU on its edges. Align the CPU keys, which are semi-circle cutouts, against the socket keys.

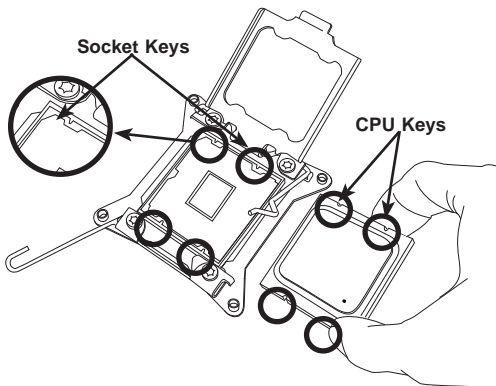

6. Once they are aligned, carefully lower the CPU straight down into the socket. (Do not drop the CPU on the socket. Do not move the CPU horizontally or vertically. Do not rub the CPU against the surface or against any pins of the socket to avoid damaging the CPU or the socket.)

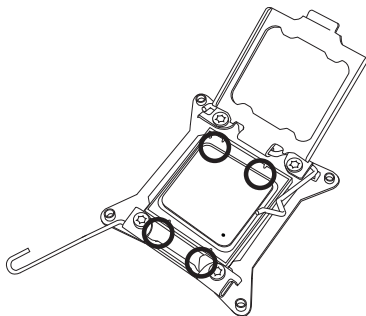

**Warning:** You can only install the CPU inside the socket in one direction. Make sure that it is properly inserted into the CPU socket before closing the load plate. If it doesn't close properly, do not force it as it may damage your CPU. Instead, open the load plate again and double-check that the CPU is aligned properly.

7. With the CPU inside the socket, inspect the four corners of the CPU to make sure that the CPU is properly installed.
8. Close the load plate with the CPU inside the socket. Lock the lever labeled 'Close 1st' first, then lock the lever labeled 'Open 1st' second. Use your thumb to gently push the load levers down to the lever locks.

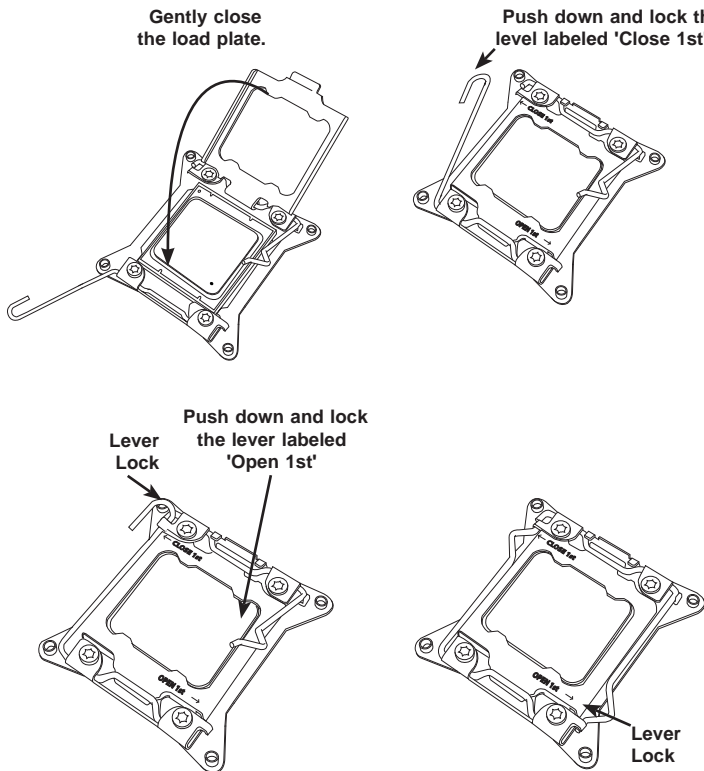

## Installing a Passive CPU Heatsink

1. Do not apply any thermal grease to the heatsink or the CPU die -- the required amount has already been applied.
2. Place the heatsink on top of the CPU so that the four mounting holes are aligned with those on the Serverboard's and the Heatsink Bracket underneath.
3. Screw in two diagonal screws (i.e., the #1 and the #2 screws) until just snug (-do not over-tighten the screws to avoid possible damage to the CPU.)
4. Finish the installation by fully tightening all four screws.

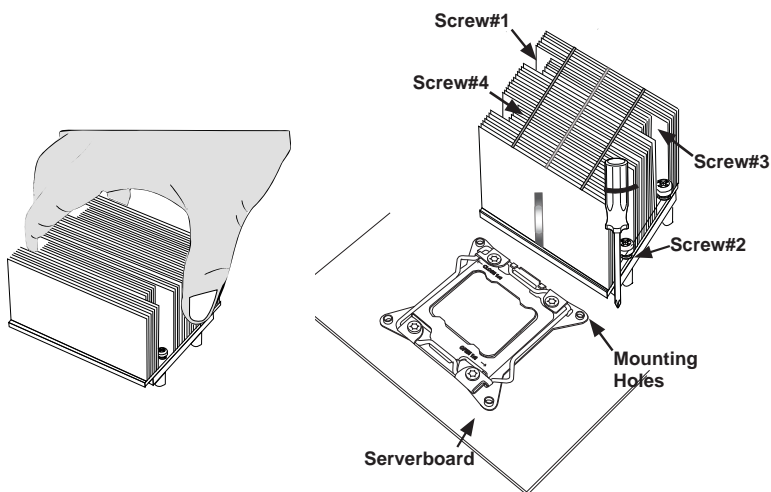

## Removing the Heatsink

**Caution:** We do not recommend that the CPU or the heatsink be removed. However, if you do need to uninstall the heatsink, please follow the instructions below to uninstall the heatsink to prevent damage done to the CPU or the CPU socket.

1. Unscrew the heatsink screws from the serverboard in the sequence as shown in the illustration below.
2. Gently wriggle the heatsink to loosen it from the CPU. (Do not use excessive force when wriggling the heatsink!)
3. Once the CPU is loosened, remove the CPU from the CPU socket.
4. Remove the used thermal grease and clean the surface of the CPU and the heatsink, Reapply the proper amount of thermal grease on the surface before reinstalling the CPU and the heatsink.

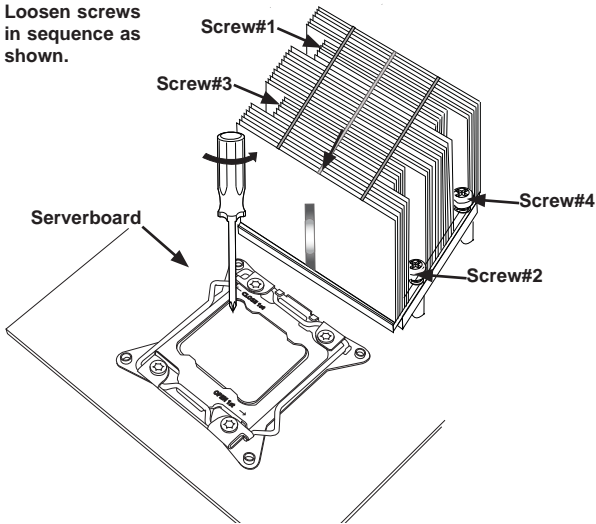

## 5-5 Installing Memory

**Caution:** exercise extreme care when installing or removing DIMMs to prevent possible damage. Remove power from the system before installing or changing memory modules.

### Installing Memory

#### Installing & Removing DIMMs

1. Insert the desired number of DIMMs into the memory slots, starting with P1-DIMMA1. (For best performance, use the memory modules of the same type and speed in the same bank.)
2. Push the release tabs outwards on both ends of the DIMM slot to unlock it.
3. Align the key along the bottom of the DIMM with the receptive point on the slot.
4. Use two thumbs together to press both ends of the module straight down into the slot until it snaps into place.
5. Push the release tabs to the locked position to secure the DIMM into the slot.
6. Unlock the release tabs to remove a DIMM from the serverboard.

### Memory Support

The X9DRG-OF/OTF supports up to 768 GB of LRDIMM or 128 GB of ECC/non-ECC UDIMM DDR3-1600/1333/1066/800 memory.

**Note:** Check the Supermicro website ([www.supermicro.com](http://www.supermicro.com)) for the latest memory support information.

Figure 5-3. Installing DIMM into Slot

**To Install:** Insert module vertically and press down until it snaps into place. Pay attention to the alignment notch at the bottom.

**To Remove:** Use your thumbs to gently push the release tabs near both ends of the module. This should release it from the slot.

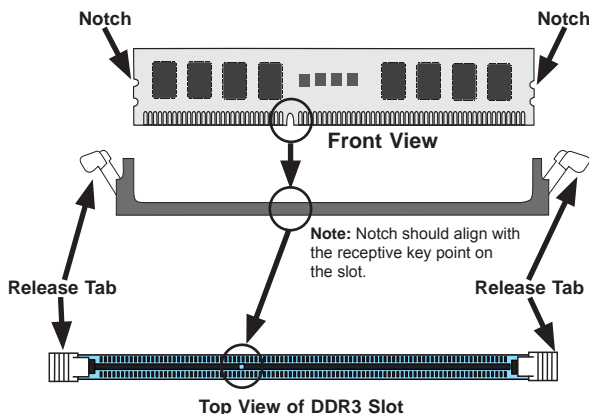

## Processor & Memory Module Population Configuration

For memory to work properly, follow the tables below for memory installation.

Processors and their Corresponding Memory Modules												
CPU#	Corresponding DIMM Modules											
<b>CPU 1 P1-DIMM</b>	A1	A2	A3	B1	B2	B3	C1	C2	C3	D1	D2	D3
<b>CPU2 P2-DIMM</b>	E1	E2	E3	F1	F2	F3	G1	G2	G3	H1	H2	H3

Processor and Memory Module Population	
Number of CPUs+DIMMs	CPU and Memory Population Configuration Table (*For memory to work properly, please follow the instructions below.)
<b>1 CPU &amp; 2 DIMMs</b>	CPU1 P1-DIMMA1/P1-DIMMB1
<b>1 CPU &amp; 4 DIMMs</b>	CPU1 P1-DIMMA1/P1-DIMMB1, P1-DIMMC1/P1-DIMMD1
<b>1 CPU &amp; 5-8 DIMMs</b>	CPU1 P1-DIMMA1/P1-DIMMB1, P1-DIMMC1/P1-DIMMD1, P1-DIMMA2/P1-DIMMB2, P1-DIMMC2/P1-DIMMD2
<b>1 CPU &amp; 9-12 DIMMs</b>	CPU1/CPU P1-DIMMA1/P1-DIMMB1, P1-DIMMC1/P1-DIMMD1, P1-DIMMA2/P1-DIMMB2, P1-DIMMC2/P1-DIMMD2, P1-DIMMA3/P1-DIMMB3, P1-DIMMC3/P1-DIMMD3
<b>2 CPUs &amp; 4 DIMMs</b>	CPU1 + CPU2 P1-DIMMA1/P1-DIMMB1, P2-DIMME1/P2-DIMMF1
<b>2 CPUs &amp; 6 DIMMs</b>	CPU1 + CPU2 P1-DIMMA1/P1-DIMMB1, P2-DIMME1/P2-DIMMF1, P1-DIMMC1/P1-DIMMD1
<b>2 CPUs &amp; 8 DIMMs</b>	CPU1 + CPU2 P1-DIMMA1/P1-DIMMB1, P2-DIMME1/P2-DIMMF1, P1-DIMMC1/P1-DIMMD1, P2-DIMMG1/P2-DIMMH1
<b>2 CPUs &amp; 9-12 DIMMs</b>	CPU1/CPU2 P1-DIMMA1/P1-DIMMB1, P2-DIMME1/P2-DIMMF1, P1-DIMMC1/P1-DIMMD1, P2-DIMMG1/P2-DIMMH1, P1-DIMMA2/P1-DIMMB2, P2-DIMME2/P2-DIMMF2
<b>2 CPUs &amp; 13 DIMMs-24 DIMMs</b>	CPU1/CPU P1-DIMMA1/P1-DIMMB1, P2-DIMME1/P2-DIMMF1, P1-DIMMC1/P1-DIMMD1, P2-DIMMG1/P2-DIMMH1, P1-DIMMA2/P1-DIMMB2, P2-DIMME2/P2-DIMMF2, P1-DIMMC2/P1-DIMMD2, P2-DIMMG2/P2-DIMMH2, P1-DIMMA3/P1-DIMMB3, P2-DIMME3/P2-DIMMF3, P1-DIMMC3/P1-DIMMD3, P2-DIMMG3/P2-DIMMH3

**Note:** For detailed information on memory support and updates, please refer to the SMC Recommended Memory List posted on our website at <http://www.supermicro.com/support/resources/mem.cfm>.

*Populating UDIMM (ECC/Non-ECC) Memory Modules*

<b>Intel E5-2600(v2) Series Processor UDIMM Memory Support</b>											
Ranks Per DIMM & Data Width	Memory Capacity Per DIMM  (See the Note below)			Speed (MT/s) and Voltage Validated by Slot per Channel (SPC) and DIMM Per Channel (DPC)							
				2 Slots Per Channel				3 Slots Per Channel			
	1DPC		2DPC		1DPC		2DPC				
	1.35V	1.5V	1.35V	1.5V	1.35V	1.5V	1.35V	1.5V			
SRx8 Non-ECC	1GB	2GB	4GB	NA	1066, 1333, 1600	NA	1066, 1333, 1600	N/A	1066, 1333, 1600	N/A	1066, 1333, 1600
DRx8 Non-ECC	2GB	4GB	8GB	NA	1066, 1333, 1600	NA	1066, 1333, 1600	N/A	1066, 1333, 1600	N/A	1066, 1333, 1600
SRx16 Non-ECC	512MB	1GB	2GB	NA	1066, 1333, 1600	NA	1066, 1333, 1600	N/A	1066, 1333, 1600	N/A	1066, 1333, 1600
SRx8 ECC	1GB	2GB	4GB	1066, 1333	1066, 1333, 1600	1066, 1333	1066, 1333, 1600	1066, 1333	1066, 1333, 1600	1066, 1333	1066, 1333, 1600
DRx8 ECC	2GB	4GB	8GB	1066, 1333	1066, 1333, 1600	1066, 1333	1066, 1333, 1600	1066, 1333	1066, 1333, 1600	1066, 1333	1066, 1333, 1600

*Populating RDIMM (ECC) Memory Modules*

<b>Intel E5-2600(v2) Series Processor RDIMM Memory Support</b>													
Ranks Per DIMM & Data Width	Memory Capacity Per DIMM  (See the Note Below)			Speed (MT/s) and Voltage Validated by Slot per Channel (SPC) and DIMM Per Channel (DPC)									
				2 Slots Per Channel				3 Slots Per Channel					
	1DPC		2DPC		1 DPC		2DPC		3DPC				
	1.35V	1.5V	1.35V	1.5V	1.35V	1.5V	1.35V	1.5V	1.35V	1.5V	1.35V	1.5V	
SRx8	1GB	2GB	4GB	1066, 1333	1066, 1333, 1600	1066, 1333	1066, 1333, 1600	1066, 1333	1066, 1333, 1600	1066, 1333	1066, 1333, 1600	800	800, 1066
DRx8	2GB	4GB	8GB	1066, 1333	1066, 1333, 1600	1066, 1333	1066, 1333, 1600	1066, 1333	1066, 1333, 1600	1066, 1333	1066, 1333, 1600	800	800, 1066
SRx4	2GB	4GB	8GB	1066, 1333	1066, 1333, 1600	1066, 1333	1066, 1333, 1600	1066, 1333	1066, 1333, 1600	1066, 1333	1066, 1333, 1600	800	800, 1066
DRx4	4GB	8GB	16GB	1066, 1333	1066, 1333, 1600	1066, 1333	1066, 1333, 1600	1066, 1333	1066, 1333, 1600	1066, 1333	1066, 1333, 1600	800	800, 1066
QRx4	8GB	16GB	32GB	800	800, 1066	800	800	800	800, 1066	800	800	N/A	N/A
QRx8	4GB	8GB	16GB	800	800, 1066	800	800	800	800, 1066	800	800	N/A	N/A

### Populating UDIMM (ECC/Non-ECC) Memory Modules

Intel E5-2600 Series Processor UDIMM Memory Support											
Ranks Per DIMM & Data Width	Memory Capacity Per DIMM (See the Note below)			Speed (MT/s) and Voltage Validated by Slot per Channel (SPC) and DIMM Per Channel (DPC)							
				2 Slots Per Channel				3 Slots Per Channel			
				1DPC		2DPC		1DPC		2DPC	
				1.35V	1.5V	1.35V	1.5V	1.35V	1.5V	1.35V	1.5V
SRx8 Non-ECC	1GB	2GB	4GB	NA	1066, 1333	NA	1066, 1333	N/A	1066, 1333	N/A	1066, 1333
DRx8 Non-ECC	2GB	4GB	8GB	NA	1066, 1333	NA	1066, 1333	N/A	1066, 1333	N/A	1066, 1333
SRx16 Non-ECC	512MB	1GB	2GB	NA	1066, 1333	NA	1066, 1333	N/A	1066, 1333	N/A	1066, 1333
SRx8 ECC	1GB	2GB	4GB	1066, 1333	1066, 1333	1066	1066, 1333	1066	1066, 1333	1066, 1333	1066, 1333
DRx8 ECC	2GB	4GB	8GB	1066, 1333	1066, 1333	1066	1066, 1333	1066	1066, 1333	1066, 1333	1066, 1333

### Populating RDIMM (ECC) Memory Modules

Intel E5-2600 Series Processor RDIMM Memory Support													
Ranks Per DIMM & Data Width	Memory Capacity Per DIMM (See the Note Below)			Speed (MT/s) and Voltage Validated by Slot per Channel (SPC) and DIMM Per Channel (DPC)									
				2 Slots Per Channel				3 Slots Per Channel					
				1DPC		2DPC		1 DPC		2DPC		3DPC	
				1.35V	1.5V	1.35V	1.5V	1.35V	1.5V	1.35V	1.5V	1.35V	1.5V
SRx8	1GB	2GB	4GB	1066, 1333	1066, 1333, 1600	1066, 1333	1066, 1333, 1600	1066, 1333	1066, 1333, 1600	1066, 1333, 1600	1066, 1333, 1600	N/A	800, 1066
DRx8	2GB	4GB	8GB	1066, 1333	1066, 1333, 1600	1066, 1333	1066, 1333, 1600	1066, 1333	1066, 1333, 1600	1066, 1333	1066, 1333, 1600	N/A	800, 1066
SRx4	2GB	4GB	8GB	1066, 1333	1066, 1333, 1600	1066, 1333	1066, 1333, 1600	1066, 1333	1066, 1333, 1600	1066, 1333	1066, 1333, 1600	N/A	800, 1066
DRx4	4GB	8GB	16GB	1066, 1333	1066, 1333, 1600	1066, 1333	1066, 1333, 1600	1066, 1333	1066, 1333, 1600	1066, 1333	1066, 1333, 1600	N/A	800, 1066
QRx4	8GB	16GB	32GB	800	1066	800	800	800	1066	800	800	N/A	N/A
QRx8	4GB	8GB	16GB	800	1066	800	800	800	1066	800	800	N/A	N/A

## 5-6 Adding PCI Expansion Cards

The 4027GR-TR/TRT supports up to eight PCI Express x16 cards.

### Installing an Expansion Card

1. After powering down the system, remove the PCI slot shield.
2. Fully seat the card into the slot, pushing down with your thumbs evenly on both sides of the card.
3. Finish by using a screw to secure the top of the card shield to the chassis.  
The PCI slot shield protects the serverboard and its components from EMI and aid in proper ventilation, so make sure it is always in place.

## 5-7 Serverboard Details

Figure 5-4. X9DRG-OF/OTF-PCIE Board Layout

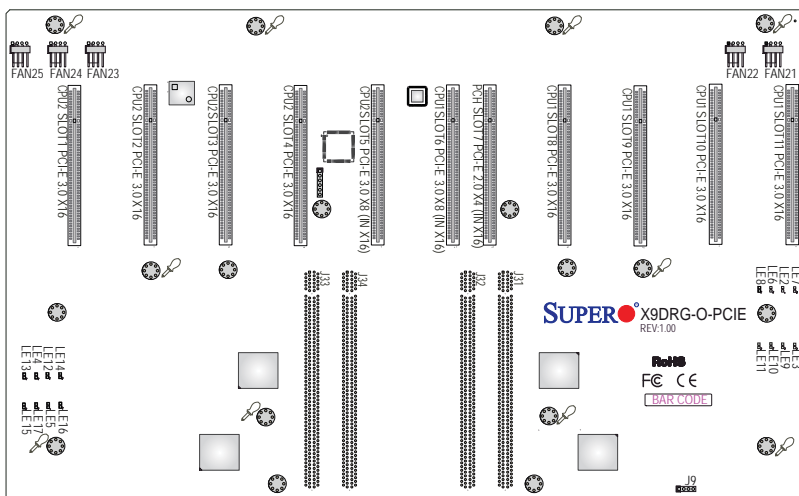
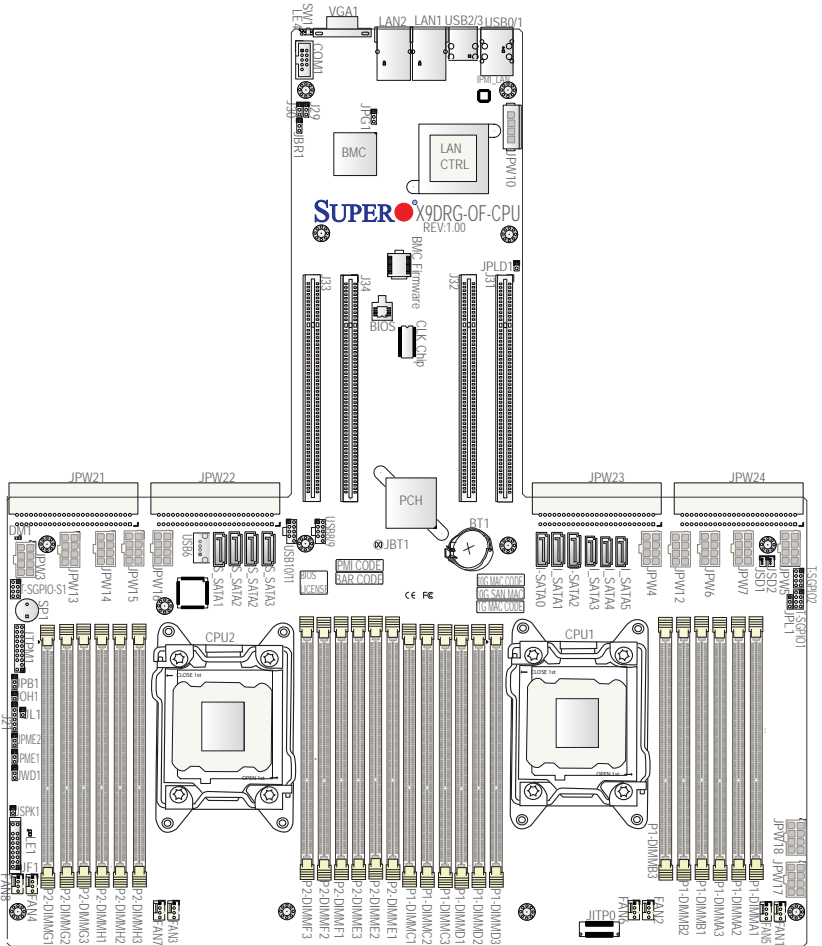

Figure 5-5. X9DRG-OF/OTFServerboard Layout



**Note:** Jumpers and connectors not indicated are for test purposes only.

## X9DRG-OF/OTF Quick Reference

Jumper	Description	Default Setting
JBR1	BIOS Recovery	Pins 1-2 (Normal)
JBT1	Clear CMOS	See Section 5-9
JPB1	BMC Enabled	Pins 1-2 (Enabled)
JPG1	VGA Enabled	Pins 1-2 (Enabled)
JPL1	GLAN1/GLAN2 Enable	Pins 1-2 (Enabled)
JPME1	Management Engine (ME) Recovery Mode	Pins 1-2 (Normal)
JPME2	Management Engine (ME) Manufacture Mode	Pins 1-2 (Normal)
JWD1	Watch Dog Timer Enable	Pins 1-2 (Reset)

Connector	Description
BT1	CMOS Battery
COM1	Serial Port (COM1) Header
FAN1-8	CPU/System Cooling Fans
J21	X9DRG-O(T)F-CPU CPLD Programming
J31/32/33/34	Slots for Riser Cards (RSC-X9DRG-O)
JF1	Front Panel Control Header
JL1	Chassis Intrusion
JOH1	Overheat LED Indicator
JPW3-JPW7, JPW12-JPW16	GPU and PCIe Add-on Card Auxilliary Power Connectors
JPW17-JPW18	HDD Backplane Power Connector
JPW21/22/23/24	Power Supply Connectors
JSD1/JSD2	SATA DOM (Device on Module) Power Connectors
JTPM1	TPM (Trusted Platform Module)/Port 80
LAN1/LAN2	10G Ethernet LAN Ports 1/2 (X9DRG-OTF), 1G LAN Ports 1/2 (X9DRG-OF)
(IPMI) LAN	Dedicated IPMI LAN
(I-)SATA 0-5	SATA 3.0 Ports (I-SATA 0/1), SATA 2.0 Connectors (I-SATA 2-5) from AHCI
S-SATA 1-4	SATA 2.0 Ports from SCU (S-SATA 1-4)
SP1	Onboard Speaker Header
SW1	UID Switch
T-SGPIO1/2	Serial Link General Purpose I/O Headers 1/2 for I-SATA Ports 0~5

T-SGPIO-S1	Serial Link General Purpose I/O Header for S-SATA Ports 1-4
USB 0/1, 2/3	Back Panel USB 2.0 Ports
USB 6	USB Internal Type A USB Header
USB 8/9	USB 2.0 Headers
USB 10/11	USB 2.0 Headers

LED	Description	State	Status
DM1	BMC Heartbeat LED	Green	BMC Normal
LE1	Standby PWR LED	Green: On	SB Power On
LE4	UID Switch LED	Blue: On	Unit Identified

#### X9DRG-O-PCIE Board

Connector	Description
JPCIE1	CPU2 Slot1 3.0 x16
JPCIE2	CPU2 Slot2 3.0 x16
JPCIE3	CPU2 Slot3 3.0 x16
JPCIE4	CPU2 Slot4 3.0 x16
JPCIE5	CPU2 Slot5 3.0 x8 (in x16)
JPCIE6	CPU1 Slot6 3.0 x8 (in x16)
JPCIE7	PCH Slot7 2.0 x4 (in x16)
JPCIE8	CPU1 Slot8 3.0 x16
JPCIE9	CPU1 Slot9 3.0 x16
JPCIE10	CPU1 Slot10 3.0 x16
JPCIE11	CPU1 Slot11 3.0 x16

LED	Description	State	Status
LE2	CPU1 Port2 Fatal Error Indicator	Static Red	Fatal Error
LE3	CPU1 Port3 Fatal Error Indicator	Static Red	Fatal Error
LE4	CPU2 Port2 Fatal Error Indicator	Static Red	Fatal Error
LE5	CPU2 Port3 Fatal Error Indicator	Static Red	Fatal Error
LE6	CPU1 Port2 Link Error Indicator	Off 1Hz Green Blinking 2Hz Green Blinking Static Green On	Link is down 2.5GT/s 5GT/s 8GT/s
LE7	CPU1 Slot8 Link Error Indicator	Off 1Hz Green Blinking 2Hz Green Blinking Static Green On	Link is down 2.5GT/s 5GT/s 8GT/s

LE8	CPU1 Slot9 Link Status Indicator	Off 1Hz Green Blinking 2Hz Green Blinking Static Green On	Link is down 2.5GT/s 5GT/s 8GT/s
LE9	CPU1 Port3 Link Status Indicator	Off 1Hz Green Blinking 2Hz Green Blinking Static Green On	Link is down 2.5GT/s 5GT/s 8GT/s
LE10	CPU1 Slot10 Link Status Indicator	Off 1Hz Green Blinking 2Hz Green Blinking Static Green On	Link is down 2.5GT/s 5GT/s 8GT/s
LE11	CPU1 Slot11 Link Status Indicator	Off 1Hz Green Blinking 2Hz Green Blinking Static Green On	Link is down 2.5GT/s 5GT/s 8GT/s
LE12	CPU2 Port2 Link Status Indicator	Off 1Hz Green Blinking 2Hz Green Blinking Static Green On	Link is down 2.5GT/s 5GT/s 8GT/s
LE13	CPU2 Slot3 Link Status Indicator	Off 1Hz Green Blinking 2Hz Green Blinking Static Green On	Link is down 2.5GT/s 5GT/s 8GT/s
LE14	CPU2 Slot4 Link Status Indicator	Off 1Hz Green Blinking 2Hz Green Blinking Static Green On	Link is down 2.5GT/s 5GT/s 8GT/s
LE15	CPU2 Port3 Link Status Indicator	Off 1Hz Green Blinking 2Hz Green Blinking Static Green On	Link is down 2.5GT/s 5GT/s 8GT/s
LE16	CPU2 Slot1 Link Status Indicator	Off 1Hz Green Blinking 2Hz Green Blinking Static Green On	Link is down 2.5GT/s 5GT/s 8GT/s
LE17	CPU2 Slot2 Link Status Indicator	Off 1Hz Green Blinking 2Hz Green Blinking Static Green On	Link is down 2.5GT/s 5GT/s 8GT/s

**Warning:** To provide adequate power supply to the system, be sure to connect all onboard power connectors to the power supply.

## 5-8 Connector Definitions

### Power Connectors

The main power to the serverboard is provided from the backplane through the JPW21, JPW22, JPW23 and JPW24 connectors. In addition, the following power connectors also need connected:

- Two HDD backplane power connectors (JPW17, JPW18)
- Ten PCI-E Add-on card auxilliary power connectors (JPW3-JPW7, JPW12-JPW16)

8-Pin PCI-E Aux. Power Connector Pin Definitions	
Pins	Definition
1~3	+12V
4~8	Ground

8-pin HDD Backplane Power Connector Pin Definitions	
Pins	Definition
1~4	Ground
5~6	+12V
7~8	+5V

**Warning:** To ensure adequate power supply to your serverboard, be sure to connect all the power connectors mentioned above to your power supply for proper system operation.

### NMI Button

The non-maskable interrupt button header is located on pins 19 and 20 of JF1. Refer to the table on the right for pin definitions.

NMI Button Pin Definitions (JF1)	
Pin#	Definition
19	Control
20	Ground

### Power LED

The Power LED connection is located on pins 15 and 16 of JF1. Refer to the table on the right for pin definitions.

Power LED Pin Definitions (JF1)	
Pin#	Definition
15	3.3V
16	PWR LED

### HDD LED/UID Switch

The HDD/UID LED connection is located on pins 13 and 14 of JF1. Attach a hard drive LED cable here to display HDD activity (including SATA). Connect a UID switch cable to use UID switch connection. The front UID switch works in conjunction with UID LED located at pins 7/8. See the table on the right for pin definitions.

HDD LED/UID Switch Pin Definitions (JF1)	
Pin#	Definition
13	UID Switch/3,3V
14	HDD Active

### NIC1/NIC2 LED Indicators

The NIC (Network Interface Controller) LED connection for LAN port 1 is located on pins 11 and 12 of JF1 and the LED connection for LAN Port 2. Attach the NIC LED cables here to display network activity. Refer to the table on the right for pin definitions.

NIC1/2 LED Pin Definitions (JF1)	
Pin#	Definition
9	NIC 2 Act. LED
10	NIC 2 Link LED
11	NIC 1 Act. LED
12	NIC 1 Link LED

### Overheat (OH)/Fan Fail/PWR Fail/ UID LED

Connect an LED cable to pins 7 and 8 of Front Control Panel to use the Overheat/Fan Fail/Power Fail and UID LED connections. The Red LED on pin 7 provides warnings of overheat, fan failure or power failure. The Blue LED on pin 8 works as the front panel UID LED indicator. The Red LED takes precedence over the Blue LED by default. Refer to the tables on the right for pin definitions.

OH/Fan Fail/ PWR Fail/Blue_UID LED Pin Definitions (JF1)	
Pin#	Definition
7	Red_LED-Cathode/OH/Fan Fail/ Power Fail5.5V.SB
8	Blue_UID LED

OH/Fan Fail/PWR Fail LED Status (Red LED)	
State	Definition
Off	Normal
On	Overheat
Flashing	Fan Fail

### Power Fail LED

The Power Fail LED connection is located on pins 5 and 6 of JF1. Refer to the table on the right for pin definitions.

PWR Fail LED Pin Definitions (JF1)	
Pin#	Definition
5	3.3V
6	PWR Supply Fail

### Reset Button

The Reset Button connection is located on pins 3 and 4 of JF1. Attach it to a hardware reset switch on the computer case. Refer to the table on the right for pin definitions.

Reset Button Pin Definitions (JF1)	
Pin#	Definition
3	Reset
4	Ground

## Power Button

The Power Button connection is located on pins 1 and 2 of JF1. Momentarily contacting both pins will power on/off the system. This button can also be configured to function as a suspend button (with a setting in the BIOS). To turn off the power when the system is in suspend mode, press the button for 4 seconds or longer. Refer to the table on the right for pin definitions.

Power Button Pin Definitions (JF1)	
Pin#	Definition
1	Signal
2	Ground

## Universal Serial Bus (USB)

Four Universal Serial Bus ports (USB 0/1, 2/3) are located on the I/O backplane to provide USB connections. (Cables are not included). See the tables on the right for pin definitions.

Backplane USB Pin Definitions	
Pin#	Definition
1	+5V
2	PO-
3	PO+
4	Ground
5	NA

## Unit Identifier Switch

A Unit Identifier (UID) switch and two LED indicators are located on the serverboard. The UID switch is located next to LAN2 port on the backplane. The rear UID LED (LE4) is located next to the UID switch. The Front Panel UID LED is located at pins 7/8 of JF1. Connect a cable to pin 8 on JF1 for Front Panel UID LED indication. When you press the UID switch, both the rear UID LED and front panel UID LED indicators will be turned on. Press the UID switch again to turn off both LED Indicators. These UID Indicators provide easy identification of a system unit that may be in need of service.

UID LED (LE) Status		
Color/State	OS	Status
Blue: On	Windows OS	Unit Identified
Blue: Blinking	Linux OS	Unit Identified

**Note:** UID can also be triggered via IPMI on the serverboard. For more information on IPMI, please refer to the IPMI User's Guide posted on our website at <http://www.supermicro.com>.

## Ethernet Ports

Two Ethernet ports (LAN1, LAN2) are located on the I/O backplane on the serverboard. These LAN ports support 10G LAN. These ports accept RJ45 type cables. Please refer to the LED Indicator Section for LAN LED information.



## Fan Headers

This serverboard has eight fan headers for CPU/system use. All these 4-pin fans headers are backward compatible with the traditional 3-pin fans. However, fan speed control is only available for 4-pin fans via IPMI thermal management. See the table on the right for pin definitions.

Fan Header Pin Definitions	
Pin#	Definition
1	Ground
2	+12V
3	Tachometer
4	Pulse Width Modulation

## Chassis Intrusion

A Chassis Intrusion header is located at JL1 on the serverboard. Attach an appropriate cable from the chassis to inform you of a chassis intrusion when the chassis is opened.

Chassis Intrusion Pin Definitions	
Pin#	Definition
1	Intrusion Input
2	Ground

## Serial Ports

A COM port header is located next to the BMC controller on the serverboard. See the table on the right for pin definitions.

Serial (COM) Port Pin Definitions			
Pin #	Definition	Pin #	Definition
1	DCD	6	DSR
2	RXD	7	RTS
3	TXD	8	CTS
4	DTR	9	RI
5	Ground	10	N/A

### TPM Header/Port 80

A Trusted Platform Module/Port 80 header is located at JTPM1 to provide TPM support and Port 80 connection. Use this header to enhance system performance and data security. See the table on the right for pin definitions.

TPM/Port 80 Header (JTPM1) Pin Definitions			
Pin#	Definition	Pin#	Definition
1	LCLK	2	GND
3	LFRAME#	4	<(KEY)>
5	LRESET#	6	+5V (X)
7	LAD 3	8	LAD 2
9	+3.3V	10	LAD1
11	LAD0	12	GND
13	SMB_CLK4	14	SMB_DAT4
15	+3V_DUAL	16	SERIRQ
17	GND	18	CLKRUN# (X)
19	LPCPD#	20	LDRQ# (X)

### Overheat LED/Fan Fail

The JOH1 header is used to connect an LED indicator to provide warnings of chassis overheating and fan failure. This LED will blink when a fan failure occurs. Refer to the tables on right for pin definitions.

Overheat LED Pin Definitions	
Pin#	Definition
1	P3V3
2	OH Active Low Signal

OH/Fan Fail LED Status	
State	Message
Solid	Overheat
Blinking (1Hz)	Fan Fail
Blinking (0.25Hz)	PWR Fail

### T-SGPIO1/2/-S1 Headers

Two T-SGPIO (Serial-Link General Purpose Input/Output) headers (T-SGPIO1/2/-S1) are located on the serverboard. These headers support a Serial Link interface for onboard SATA connections. See the table on the right for pin definitions.

T-SGPIO Pin Definitions			
Pin#	Definition	Pin#	Definition
1	NC	2	NC
3	Ground	4	Data
5	Load	6	Ground
7	Clock	8	NC

**Note:** NC= No Connection

### Speaker Header

The speaker header (JSPK1) for a buzzer can be used to provide audible indications for various beep codes. See the table on the right for pin definitions. Refer to the layout below for the locations of the speaker header.

Speaker Header Pin Definition		
Pin#	Definitions	
Pin 1	Pos. (+)	5V
Pin 2	Neg. (-)	Alarm Speaker

### DOM Power Connector

The power connectors for SATA DOM (Disk On Module) devices are located at JSD1 and JSD2. Connect an appropriate cable here to provide backup power support for your SATA DOM devices to retain cache data during power outage. See the table on the right for pin definitions.

DOM Power Pin Definitions	
Pin#	Definition
1	+5V
2	Ground
3	Ground

## 5-9 Jumper Settings

### Explanation of Jumpers

To modify the operation of the serverboard, jumpers can be used to choose between optional settings. Jumpers create shorts between two pins to change the function of the connector. Pin 1 is identified with a square solder pad on the printed circuit board. See the diagram at right for an example of jumping pins 1 and 2. Refer to the serverboard layout page for jumper locations.

**Note:** On two-pin jumpers, "Closed" means the jumper is on and "Open" means the jumper is off the pins.

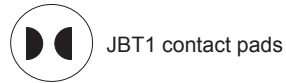
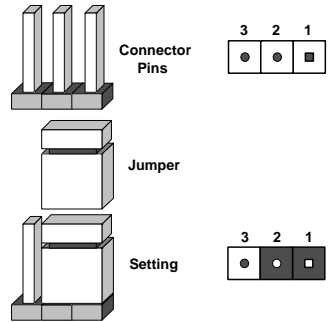

JBT1 contact pads

### CMOS Clear

JBT1 is used to clear CMOS, which will also clear any passwords. Instead of pins, this jumper consists of contact pads to prevent accidentally clearing the contents of CMOS.

#### To Clear CMOS

1. First power down the system and unplug the power cord(s). It is also recommended that you remove the onboard battery from the serverboard.
2. With the power disconnected, short the CMOS pads with a metal object such as a small screwdriver.
3. Remove the screwdriver (or shorting device).
4. Reconnect the power cord(s) and power on the system.

**Note:** Do not use the PW\_ON connector to clear CMOS.

### LAN Enable/Disable

JPL1 enables or disables the LAN1 and LAN2 ports on the serverboard. See the table on the right for jumper settings. The default setting is Enabled.

LAN Enable/Disable Jumper Settings	
Jumper Setting	Definition
Pins 1-2	Enabled
Pins 2-3	Disabled

**VGA Enable**

Jumper JPG1 allows the user to enable the onboard VGA connector. The default setting is 1-2 to enable the connection. See the table on the right for jumper settings.

VGA Enable/Disable Jumper Settings	
Jumper Setting	Definition
Pins 1-2	Enabled
Pins 2-3	Disabled

**BMC Enable**

Jumper JPB1 allows you to enable the embedded BMC (Baseboard Management) Controller to provide IPMI/KVM support on the serverboard. See the table on the right for jumper settings.

BMC Enable/Disable Jumper Settings	
Jumper Setting	Definition
Pins 1-2	BMC Enabled (Default)
Pins 2-3	Disabled

**Management Engine (ME) Recovery**

Use jumper JPME1 to select ME Firmware Recovery mode, which will limit resource allocation for essential system operation only in order to maintain normal power operation and management. In the single operation mode, online upgrade will be available via Recovery mode. See the table on the right for jumper settings.

ME Recovery Jumper Settings	
Jumper Setting	Definition
Pins 1-2	Normal (Default)
Pins 2-3	ME Recovery

**Manufacture Mode Select**

Close pins 2 and 3 of jumper JPME2 to bypass SPI flash security and force the system to operate in the Manufacture Mode, allowing the user to flash the system firmware from a host server for system setting modifications. See the table on the right for jumper settings.

ME Mode Select Jumper Settings	
Jumper Setting	Definition
Pins 1-2	Normal (Default)
Pins 2-3	Manufacture Mode

### Watch Dog Enable/Disable

Watch Dog (JWD1) is a system monitor that will reboot the system when a software application hangs. Close pins 1-2 to reset the system if an application hangs. Close pins 2-3 to generate a non-maskable interrupt signal for the application that hangs. See the table on the right for jumper settings. Watch Dog must also be enabled in the BIOS.

Watch Dog Jumper Settings	
Jumper Setting	Definition
Pins 1-2	Reset (default)
Pins 2-3	NMI
Open	Disabled

## 5-10 Onboard Indicators

### Onboard Power LED

An Onboard Power LED is located at LE1 on the serverboard. When this LED is lit, the system is on. Be sure to turn off the system and unplug the power cord before removing or installing components. See the tables at right for more information.

Onboard Power LED Indicator (LE1)	
LED Color	Definition
Off	System Off (PWR cable not connected)
Green	System On
Green: Flashing Quickly	ACPI S1 State
Green: Flashing Slowly	ACPI S3 (STR) State

### BMC Heartbeat LED

A BMC Heartbeat LED is located at DM1 on the serverboard. When DM1 is blinking, the BMC is functioning normally. See the table at right for more information.

BMC Heartbeat LED (DM1) Status	
Color/State	Definition
Green: Blinking	BMC:Normal

### GLAN LEDs

There are two Ethernet LAN ports on the serverboard. Each LAN port has two LEDs. The Yellow LED on the right indicates connection and activity. The Link LED on the left side may be green, amber or off to indicate the speed of the connection. 10G\_LAN support is available on the X9QR7-TF/JTF only. See the tables at right for more information.



GLAN Activity Indicator (Right) LED Settings		
Color	Status	Definition
Off	No Connections	
Yellow	Flashing	Active

GLAN Link Speed Indicator LED Settings	
LED Color	Definition
Off	No Connection, 10 or 100 Mbps
Green	10 Gb (for X9QR7-TF/JTF only)
Amber	1 Gbps

### IPMI Dedicated LAN LEDs

In addition to LAN 1/LAN 2, an IPMI Dedicated LAN is also located on the I/O Backplane of the serverboard. The amber LED on the right indicates connection and activity, while the green LED on the left indicates the speed of the connection. See the tables at right for more information.

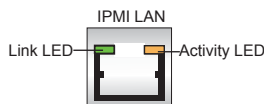

IPMI LAN Link Speed LED & Connection Activity LED		
LED	Color/State	Definition
Off	Off	No Connection
Activity	Amber: Blinking	Active
Speed	Green: Solid	100 Mbps

## 5-11 SATA Ports

### Serial ATA Ports

There are two SATA 3.0 Ports (I-SATA0/1) and four SATA 2.0 ports (I-SATA2-I-SATA5) on the motherboard. In addition, there are four S-SATA 2.0 ports (S-SATA1-S-SATA4). See the table on the right for pin definitions.

SATA Port Pin Definitions	
Pin #	Definition
1	Ground
2	TXP
3	TXN
4	Ground
5	RXN
6	RXP
7	Ground

**Note:** For more information on SATA or SAS RAID configuration, please refer to the Intel SATA HostRAID and LSI SAS MegaRAID User's Guides on our Website @ <http://www.supermicro.com>..

## 5-12 Installing Software

The Supermicro ftp site contains drivers and utilities for your system at <ftp://ftp.supermicro.com>. Some of these must be installed, such as the chipset driver.

After accessing the ftp site, go into the CDR\_Images directory and locate the ISO file for your serverboard. Download this file to create a CD/DVD of the drivers and utilities it contains. (You may also use a utility to extract the ISO file if preferred.)

Another option is to go to the Supermicro Website at <http://www.supermicro.com/products/>. Find the product page for your serverboard here, where you may download individual drivers and utilities.

After creating a CD/DVD with the ISO files, insert the disk into the CD/DVD drive on your system and the display shown in Figure 5-6 should appear.

**Figure 5-6. Driver/Tool Installation Display Screen**

**Note:** Click the icons showing a hand writing on paper to view the readme files for each item. Click the computer icons to the right of these items to install each item (from top to the bottom) one at a time. **After installing each item, you must re-boot the system before moving on to the next item on the list.** The bottom icon with a CD on it allows you to view the entire contents.

## SuperDoctor III

The SuperDoctor® III program is a web-based management tool that supports remote management capability. It includes Remote and Local Management tools. The local management is called SD III Client. The SuperDoctor III program allows you to monitor the environment and operations of your system. SuperDoctor III displays crucial system information such as CPU temperature, system voltages and fan status. See the figures below for examples of the SuperDoctor III interface.

**Note:** The default User Name and Password for SuperDoctor III is ADMIN / ADMIN.

**Note:** When SuperDoctor III is first installed, it adopts the temperature threshold settings that have been set in BIOS. Any subsequent changes to these thresholds must be made within SuperDoctor III, as the SuperDoctor III settings override the BIOS settings. To set the BIOS temperature threshold settings again, you would first need to uninstall SuperDoctor III.

Figure 5-7. SuperDoctor III Interface Display Screen (Health Information)

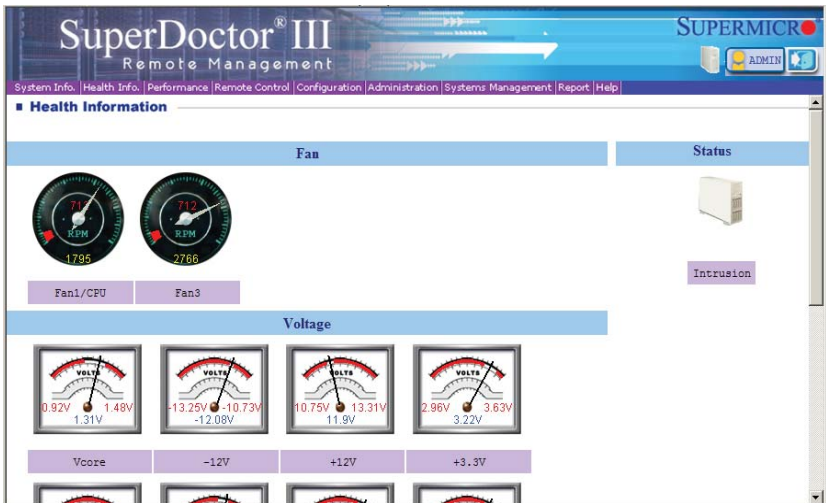
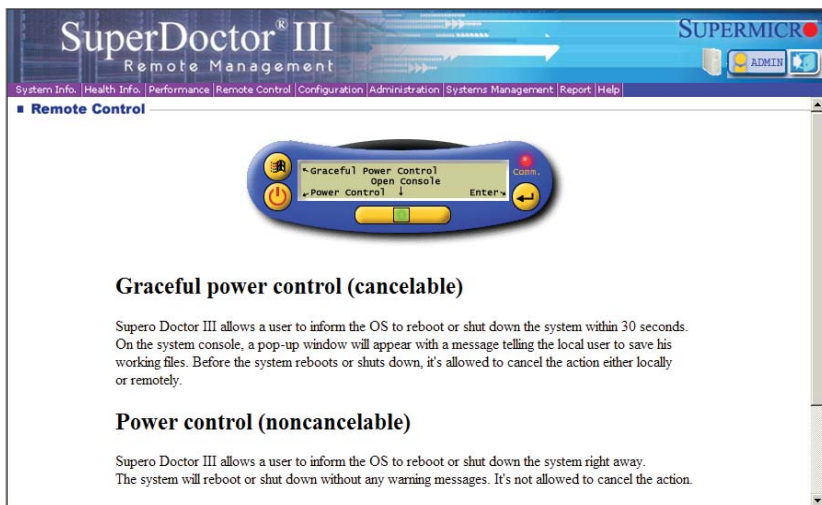

Figure 5-8. SuperDoctor III Interface Display Screen (Remote Control)



**Note:** The SuperDoctor III program and User's Manual can be downloaded from the Supermicro web site at <http://www.supermicro.com/products/accessories/software/SuperDoctorIII.cfm>. For Linux, we recommend that you use the SuperDoctor II application instead.

## 5-13 Onboard Battery

**Caution:** There is a danger of explosion if the onboard battery is installed upside down, which will reverse its polarities (see Figure 5-9). This battery must be replaced only with the same or an equivalent type recommended by the manufacturer (CR2032). Dispose of used batteries according to the manufacturer's instructions.

**Figure 5-9. Installing the Onboard Battery**

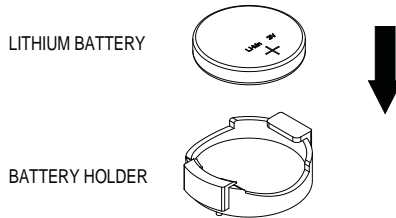

Please handle used batteries carefully. Do not damage the battery in any way; a damaged battery may release hazardous materials into the environment. Do not discard a used battery in the garbage or a public landfill. Please comply with the regulations set up by your local hazardous waste management agency to dispose of your used battery properly.

## Chapter 6

### Advanced Chassis Setup

This chapter covers the steps required to install components and perform maintenance on the SC418GTS-GTS-R3200B chassis. For component installation, follow the steps in the order given to eliminate the most common problems encountered. If some steps are unnecessary, skip ahead to the step that follows.

**Tools Required:** The only tool you will need to install components and perform maintenance is a Philips screwdriver.

#### 6-1 Static-Sensitive Devices

Electrostatic discharge (ESD) can damage electronic components. To prevent damage to any printed circuit boards (PCBs), it is important to handle them very carefully. The following measures are generally sufficient to protect your equipment from ESD damage.

##### Precautions

- Use a grounded wrist strap designed to prevent static discharge.
- Touch a grounded metal object before removing any board from its antistatic bag.
- Handle a board by its edges only; do not touch its components, peripheral chips, memory modules or gold contacts.
- When handling chips or modules, avoid touching their pins.
- Put the serverboard, add-on cards and peripherals back into their antistatic bags when not in use.
- For grounding purposes, make sure your computer chassis provides excellent conductivity between the power supply, the case, the mounting fasteners and the serverboard.

##### Unpacking

The serverboard is shipped in antistatic packaging to avoid static damage. When unpacking the board, make sure the person handling it is static protected.

Figure 6-1. Front and Rear Chassis Views

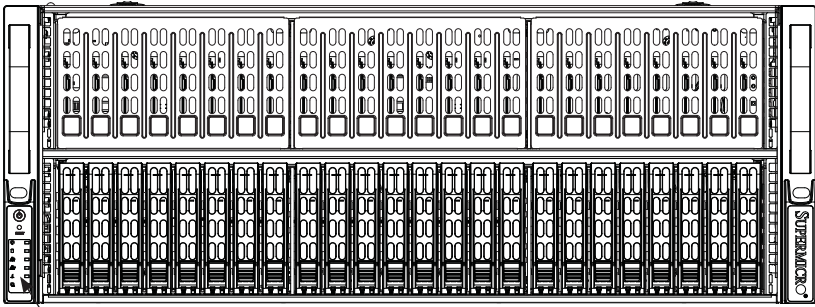

Control Panel

Hard Drives (24)

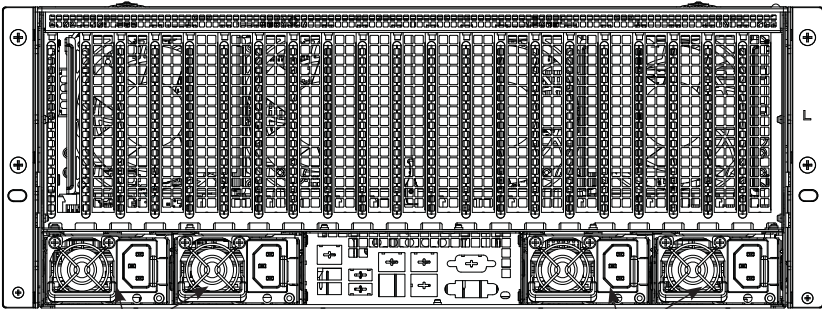

Power Supplies

I/O Ports

Power Supplies

## 6-2 Control Panel

The control panel is located on the front of the chassis. The LEDs inform you of system status.

See Chapter 3 for details on the LEDs and the control panel buttons.

## 6-3 Installing Hard Drives

The SC418GTS supports a total of 24 hard disk drives, which are mounted in drive carriers and reside within the the hard drive bays. These drives are hot-swappable and can be removed or replaced without powering down the chassis. Enterprise SAS or SATA HDDs only are recommended.

### ***Removing Hard Drives and their Carriers from the Hard Drive Bays***

1. Press the release button on the drive carrier. This extends the drive carrier handle.
2. Use the handle to pull the drive and its carrier out of the chassis.

**Figure 6-2. Removing a Hard Drive Carrier**

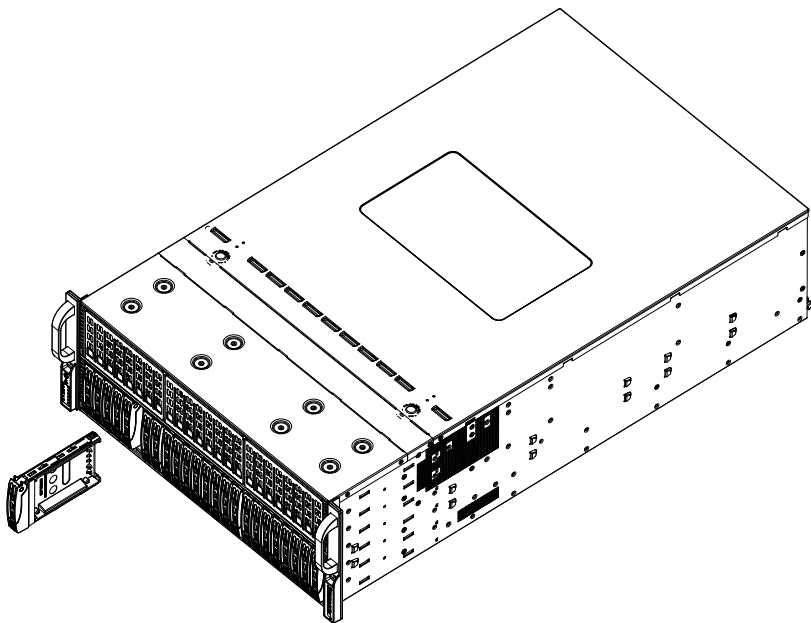

Enterprise level hard disk drives are recommended for use in Supermicro chassis and servers. For information on recommended HDDs, visit the Supermicro Web site at <http://www.supermicro.com/products/info/files/storage/SAS-1-CompList-110909.pdf>

***Installing a Hard Drive into a Drive Carrier***

1. Insert a drive into the carrier with the PCB side facing down and the connector end toward the rear of the carrier.
2. Align the drive in the carrier so that the screw holes of both line up. Note that there are holes in the carrier marked "SATA" to aid in correct installation.
3. Secure the drive to the carrier with four screws as illustrated below.
4. Insert the drive carrier into its bay, keeping the carrier oriented so that the hard drive is on the top of the carrier and the release button is on the right side. When the carrier reaches the rear of the bay, the release handle will retract.
5. Push the handle in until it clicks into its locked position.

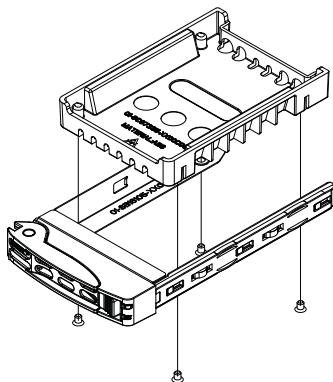
**Figure 6-3. Removing a Dummy Drive from a Tray**

## 6-4 Accessing the Inside of the System

### Removing the Chassis Cover

You will need to access the inside of the system to complete certain procedures such as replacing fans.

#### *Removing the Chassis Cover*

If working with components such as memory, processors or heatsinks, start by shutting the system down and disconnecting the AC power cord.

1. Depress the two release buttons on both sides of the cover.
2. Slide the cover toward the rear of the chassis
3. Lift the cover off the chassis.

Figure 6-4. Accessing the Inside of the System

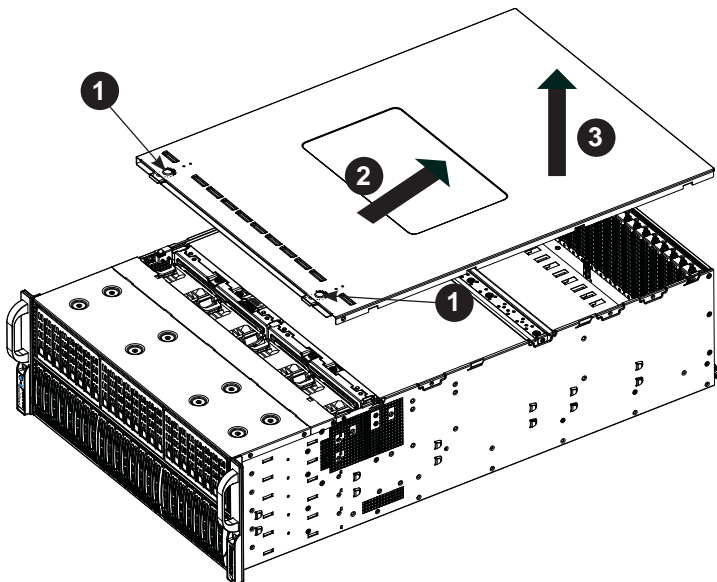

**Warning:** Except for short periods of time, do NOT operate the server without the cover in place. The chassis cover must be in place to allow proper airflow and prevent overheating.

## 6-5 Installing the Air Shroud

### Air Shrouds

Air shrouds concentrate airflow to maximize fan efficiency. Two air shrouds are included in the system: one for the CPUs and another for the PCI slots. The CPU air shroud, which sits behind the system fans, should be installed into the chassis first. These air shrouds do not require screws to install.

#### *Installing the CPU Air Shroud*

1. Confirm that all fans are in place and working properly.
2. Remove the fan bracket screws (one each on the left and right sides of chassis. **Note:** There are four serrated cutouts on the left and right sides of the rear edge of the shroud. Depending on your system configuration and GPU configuration, you will have to remove one or two of these cutouts to route the GPU power and SATA cables through the shroud.
3. Lift the fan bracket up a few inches (be careful not to raise it too far as doing so may disconnect the fans). With the fan bracket raised, install the CPU air shroud front side first. Then place the fan bracket back in its original position.
4. Route the GPU power and SATA data cables through the cutouts and place the rear edge of the air shroud between the PCI-E PCB and the mounting plate.
5. Replace the two fan bracket screws to finish.

Figure 6-5. CPU Air Shroud Placement

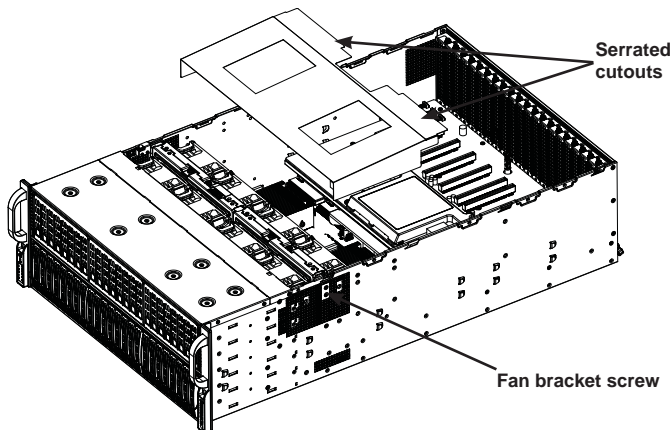

**Installing the PCI-E Air Shroud**

1. Remove the GPU retention bracket screw (located on the right side) and remove the GPU retention bracket.
2. Noting the front and rear sides of the air shroud, insert the sides of the air shroud between the chassis and GPU1 and GPU8. Insert the interior air shroud slots between GPU2/GPU3 and GPU6/GPU7. Finally, insert the center of the air shroud between GPU4 and GPU5.
3. Adjust the air shroud so that front edge is flush with the fan bracket.
4. Re-install the GPU retention bracket.

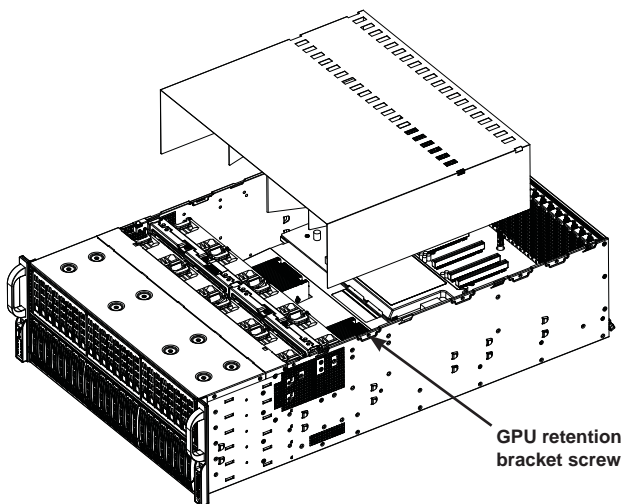
**Figure 6-6. PCI Air Shroud Placement**

## 6-6 Cooling System

The SC418GTS chassis contains eight 9-cm system fans that provide cooling for the system. All eight fans are hot-swappable. There is no need to power down the system when switching fans.

### *Changing a System Fan*

1. If necessary, open the chassis while the power is running to determine which fan has failed. (Never run the server for an extended period of time with the chassis cover open).
2. Press the fan housing lever to unlock the fan from the bracket.
3. While applying pressure to fan housing lever, gently push the fan upwards from underneath the fan housing to remove it.
4. Place the new fan into the vacant space in the housing. Make sure to apply pressure to the top of the new fan to lock it into the fan housing. The new fan should 'click' into place.
5. Confirm that the fan is working properly before replacing the chassis cover.

Figure 6-6. Replacing a System Fan

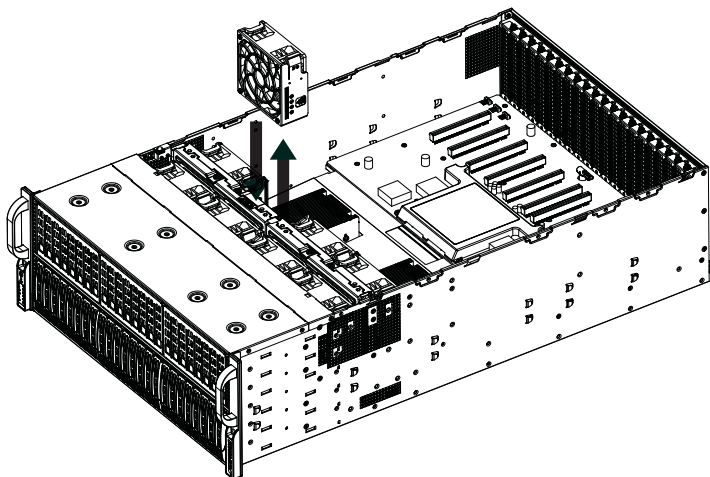

## 6-7 Power Supply

The 4027GR-TR/TRT has four redundant, high-efficiency 1600 Watt power supplies. These power supplies are auto-switching capable, enabling it to automatically sense and operate at a 100v to 240v input voltage. An amber light will be illuminated on the power supply when the power is off. An illuminated green light indicates that the power supply is operating.

### Power Supply Replacement

In the event that one of the power supplies needs to be replaced, one power supply can be removed without powering-down the system. Replacement power supply units may be ordered directly from Supermicro.

#### *Changing the Power Supply*

1. With the system running, unplug the AC power cord from the failed power supply module.
2. Push and hold the release tab on the back of the power supply.
3. Grasp the handle and pull the power supply out of its bay.
4. Push the replacement power supply module into the empty bay until it clicks into the locked position.
5. Plug the AC power cord back into the power supply module.

Figure 6-8. Replacing a Power Supply

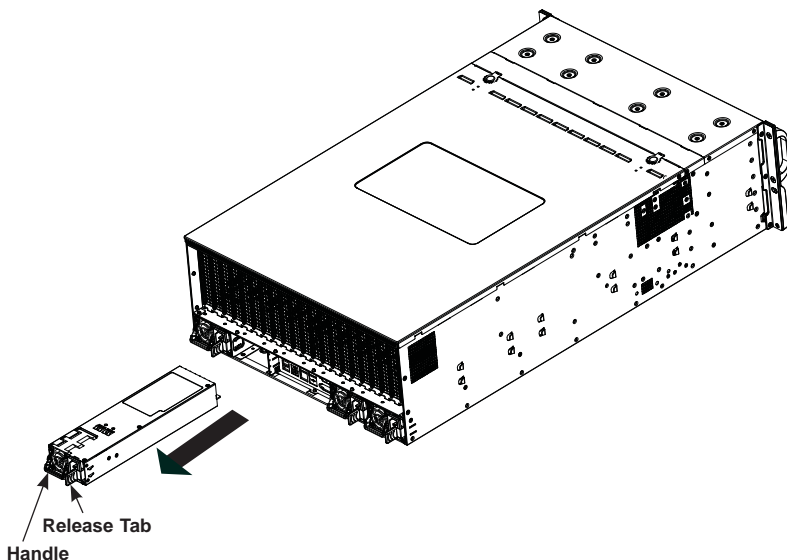

# Notes

# Chapter 7

## BIOS

### 7-1 Introduction

This chapter describes the AMI BIOS setup utility for the X9DRG-O(T)F-CPU/X9DRG-O-PCIE Platform. It also provides the instructions on how to navigate the AMI BIOS setup utility screens. The AMI ROM BIOS is stored in a Flash EEPROM and can be easily updated.

#### Starting BIOS Setup Utility

To enter the AMI BIOS setup utility screens, press the <Del> key while the system is booting up.

**Note:** In most cases, the <Del> key is used to invoke the AMI BIOS setup screen. There are a few cases when other keys are used, such as <F3>, <F4>, etc.

Each main BIOS menu option is described in this manual. The Main BIOS setup menu screen has two main frames. The left frame displays all the options that can be configured. Grayed-out options cannot be configured. Options in blue can be configured by the user. The right frame displays the key legend. Above the key legend is an area reserved for informational text related to the option currently selected in the left frame.

**Note:** The AMI BIOS has default informational messages built in. The manufacturer retains the option to include, omit, or change any of these informational messages.

The AMI BIOS setup utility uses a key-based navigation system called "hot keys." Most of the AMI BIOS setup utility "hot keys" can be used at any time during setup navigation. These keys include <F3>, <F4>, <Enter>, <ESC>, arrow keys, etc.

**Note 1:** In this section, options printed in **Bold** are default settings.

**Note 2:** <F3> is used to load optimal default settings. <F4> is used to save the settings and exit the setup utility.

## How To Change the Configuration Data

The configuration data that determines the system parameters may be changed by entering the AMI BIOS setup utility. This setup utility can be accessed by pressing <Delete> at the appropriate time during system boot.

**Note:** For AMI UEFI BIOS Recovery, please refer to the UEFI BIOS Recovery User Guide posted @<http://www.supermicro.com/support/manuals/>.

## Starting the Setup Utility

Normally, the only visible Power-On Self-Test (POST) routine is the memory test. As the memory is being tested, press the <Delete> key to enter the main menu of the AMI BIOS setup utility. From the main menu, you can access the other setup screens. An AMI BIOS identification string is displayed at the left bottom corner of the screen below the copyright message.

**Warning:** Do not upgrade the BIOS unless your system has a BIOS-related issue. Flashing the wrong BIOS can cause irreparable damage to the system. In no event shall the manufacturer be liable for direct, indirect, special, incidental, or consequential damage arising from a BIOS update. If you have to update the BIOS, do not shut down or reset the system while the BIOS is being updated to avoid possible boot failure.

## 7-2 Main Setup

When you first enter the AMI BIOS setup utility, you will enter the Main setup screen. You can always return to the Main setup screen by selecting the Main tab on the top of the screen. The Main BIOS setup menu screen is shown below.



The AMI BIOS main menu displays the following information:

**System Date**

This item displays the system date in Day MM/DD/YYYY format (e.g. Wed 01/15/2014).

**System Time**

This item displays the system time in HH:MM:SS format (e.g. 15:32:52).

**Supermicro X9DRG-O(T)F****Version**

This item displays the SMC version of the BIOS ROM used in this system.

**Build Date**

This item displays the date that the BIOS ROM was built.

**Memory Information****Total Memory**

This displays the amount of memory that is available in the system.

## 7-3 Advanced Setup Configurations

Use the arrow keys to select Advanced setup menu and press <Enter> to access the following submenu items.

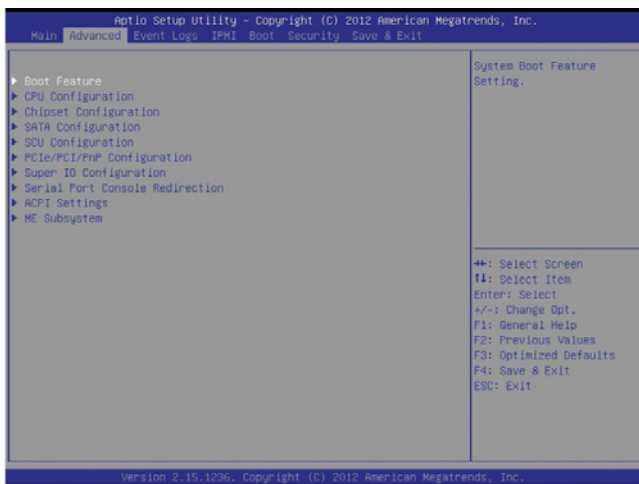

### ► Boot Feature

#### Quiet Boot

This feature allows the user to select the bootup screen display between POST messages and the OEM logo. Select Disabled to display the POST messages. Select Enabled to display the OEM logo instead of the normal POST messages. The options are **Enabled** and Disabled.

#### AddOn ROM Display Mode

Use this item to set the display mode for the Option ROM. Select Keep Current to use the current AddOn ROM Display setting. Select Force BIOS to use the Option ROM display mode set by the system BIOS. The options are **Force BIOS** and Keep Current.

#### Bootup Num-Lock

Use this feature to set the Power-on state for the Num Lock key. The options are Off and **On**.

#### Wait For 'F1' If Error

Select Enabled to force the system to wait until the 'F1' key is pressed if an error occurs. The options are Disabled and **Enabled**.

### Interrupt 19 Capture

Interrupt 19 is the software interrupt that handles the boot disk function. When this item is set to Enabled, the ROM BIOS of the host adaptors will "capture" Interrupt 19 at bootup and allow the drives that are attached to these host adaptors to function as bootable disks. If this item is set to Disabled, the ROM BIOS of the host adaptors will not capture Interrupt 19, and the drives attached to these adaptors will not function as bootable devices. The options are **Enabled** and Disabled.

### Re-try Boot

Use this item to select the type of the bootable device that the BIOS will continuously try to boot the system from. The options are **Disabled**, Legacy Boot, and EFI Boot.

## Power Configuration

### Watch Dog Function

If enabled, the Watch Dog timer will allow the system to automatically reboot when a non-recoverable error occurs that lasts for more than five minutes. The options are Enabled and **Disabled**.

### Power Button Function

If this feature is set to Instant Off, the system will power off immediately as soon as the user presses the power button. If this feature is set to 4 Seconds Override, the system will power off when the user presses the power button for 4 seconds or longer. The options are **Instant Off** and 4 Seconds Override.

### Restore on AC Power Loss

Use this feature to set the power state after a power outage. Select Stay Off for the system power to remain off after a power loss. Select Power On for the system power to be turned on after a power loss. Select Last State to allow the system to resume its last state before a power loss. The options are Power On, Stay Off, and **Last State**.

## ► CPU Configuration

This submenu displays the CPU information as detected by the BIOS. It also allows the user to configure CPU settings.

### ► Socket 1 CPU Information/Socket 2 CPU Information

This submenu displays the following information regarding the CPU installed in Socket 1 or Socket 2.

- Type of CPU

- CPU Signature
- Microcode Patch
- CPU Stepping
- Max (Maximum) CPU Speed
- Min (Minimum) CPU Speed
- Processor Cores
- Intel HT (Hyper-Threading) Technology
- Intel VT-x Technology
- Intel SMX Technology
- L1 Data Cache
- L1 Code Cache
- L2 Cache
- L3 Cache

### **CPU Speed**

This item displays the speed of the CPU installed in the Socket selected.

### **64-bit**

This item indicates if 64-bit technology is supported by the CPU installed in the socket specified.

### **Clock Spread Spectrum**

Select Enable to enable Clock Spread Spectrum support, which will allow the BIOS to monitor and attempt to reduce the level of Electromagnetic Interference caused by the components when needed. The options are **Disabled** and Enabled.

### **RTID (Record Types IDs)**

Use this item to configure the RTID setting which determines how the system memory should be accessed. Select Optimal for all normal applications and benchmarking operations. Select Alternate for I/O-intensive applications that require direct access to the system memory. The options are **Optimal** and Alternate.

### Hyper-threading

Select Enabled to support Intel Hyper-threading Technology to enhance CPU performance. The options are **Enabled** and Disabled.

### Active Processor Cores

Set to Enabled to use a processor's second core and above. (Please refer to Intel's website for more information.) The options are **All**, 1, 2, 3, 4, 5, 6, 7, 8, 9, 10, and 11.

### Limit CPUID Maximum

This feature allows the user to set the maximum CPU ID value. Enable this function to boot the legacy operating systems that cannot support processors with extended CPUID functions. The options are Enabled and **Disabled** (for the Windows OS).

### Execute-Disable Bit (Available if supported by the OS & the CPU)

Select Enabled to enable the Execute Disable Bit which will allow the processor to designate areas in the system memory where an application code can execute and where it cannot, thus preventing a worm or a virus from flooding illegal codes to overwhelm the processor or damage the system during an attack. The default is **Enabled**. (Refer to Intel and Microsoft Web sites for more information.)

### Intel® AES-NI

Select Enable to use the Intel Advanced Encryption Standard (AES) New Instructions (NI) technology to ensure data security. The options are **Enabled** and Disabled.

### MLC Streamer Prefetcher (Available when supported by the CPU)

If set to Enabled, the prefetcher for the MLC (mid-level cache) streamer will prefetch streams of data and instructions from the main memory to the L2 cache to improve CPU performance. The options are Disabled and **Enabled**.

### MLC Spatial Prefetcher (Available when supported by the CPU)

If this feature is set to Disabled, the CPU prefetches the cache line for 64 bytes. If this feature is set to Enabled the CPU fetches both cache lines for 128 bytes as comprised. The options are Disabled and **Enabled**.

### DCU Streamer Prefetcher (Available when supported by the CPU)

Select Enabled for the Data Cache Unit (DCU) prefetcher to prefetch L1 data for CPU use in an effort to speed up data accessing and processing in the DCU. The options are Disabled and **Enabled**.

### DCU IP Prefetcher

Select Enabled to activate the DCU (Data Cache Unit) IP prefetcher so that it will prefetch IP addresses to improve network connectivity and system performance. The options are **Enabled** and Disabled.

---

**Intel® Virtualization Technology (Available when supported by the CPU)**

Select Enabled to support Intel Virtualization Technology, which will allow one platform to run multiple operating systems and applications simultaneously in multiple partitions, creating multiple "virtual" systems in one physical computer. The options are **Enabled** and Disabled.

**Note:** If there is any change to this setting, you will need to reboot the system for the change to take effect. Please refer to Intel's website for detailed information.)

**PPIN Support (Available when supported by the CPU)**

Select Enabled to enable Protected Processor Inventory Number (PPIN) support, which will allow the Ivy Bridge server processors to return 64-bit ID numbers. The options are **Enabled** and Disabled.

**► CPU Power Management Configuration**

This submenu allows the user to configure the following CPU Power Management settings.

**Power Technology**

Select Energy Efficiency to support power-saving mode. Select Custom to customize system power settings. Select Disabled to disable power-saving features. Select Max Performance to configure power mode to allow for maximum system performance. The options are Disabled, **Energy Efficient**, Custom and Max Performance. If the option is set to Custom, the following items will display:

**EIST (Available when Power Technology is set to Custom)**

Select Enabled to support EIST (Enhanced Intel SpeedStep Technology) which will allow the system to automatically adjust processor voltage and core frequency to reduce power consumption and heat dissipation. The options are Disabled and **Enabled**.

**Turbo Mode (Available when Power Technology is set to Custom and EIST is enabled)**

This feature allows processor cores to run faster than marked frequency in specific conditions. The options are Disabled and **Enabled**.

**C1E Support (Available when Power Technology is set to Custom)**

Select Enabled to enable Enhanced C1 Power State to boost system performance. The options are **Enabled** and Disabled.

**CPU C3 Report (Available when Power Technology is set to Custom)**

Select Enabled to allow the BIOS to report the CPU C3 State (ACPI C2) to the operating system. During the CPU C3 State, the CPU clock generator is turned off. The options are Enabled and **Disabled**.

**CPU C6 Report (Available when Power Technology is set to Custom)**

Select Enabled to allow the BIOS to report the CPU C6 State (ACPI C3) to the operating system. During the CPU C6 State, the power to all cache is turned off. The options are **Enabled** and Disabled.

**Package C State limit (Available when Power Technology is set to Custom)**

This feature allows the user to set the limit on the C-State package register. The options are C0, C2, **C6**, and No Limit.

**Energy/Performance Bias**

Use this feature to select an appropriate fan setting to achieve maximum system performance (with maximum cooling) or maximum energy efficiency (with maximum power saving). The fan speeds are controlled by the firmware management via IPMI 2.0. The options are Performance, **Balanced Performance**, Balanced Energy, and Energy Efficient.

**Factory Long Duration Power Limit**

This item displays the power limit (in watts) set by the manufacturer during which long duration power is maintained.

**Long Duration Power Limit**

This item displays the power limit (in watts) set by the user during which long duration power is maintained. The default setting is **0**.

**Factory Long Duration Maintained**

This item displays the period of time (in seconds) set by the manufacturer during which long duration power is maintained.

**Long Duration Maintained**

This item displays the period of time (in seconds) during which long duration power is maintained. The default setting is **0**.

### **Recommended Short Duration Power Limit**

This item displays the short duration power settings (in watts) recommended by the manufacturer.

### **Short Duration Power Limit**

This item displays the time period during which short duration power (in watts) is maintained. The default setting is **0**.

## **► Chipset Configuration**

### **► North Bridge**

This feature allows the user to configure the settings for the Intel North Bridge.

### **► Integrated IO Configuration**

#### **Intel® VT-d**

Select Enabled to enable Intel Virtualization Technology support for Direct I/O VT-d by reporting the I/O device assignments to the VMM (Virtual Machine Monitor) through the DMAR ACPI Tables. This feature offers fully-protected I/O resource sharing across Intel platforms, providing greater reliability, security and availability in networking and data-sharing. The options are **Enabled** and **Disabled**.

#### **Ageing Timer Rollover**

Use this feature to determine how long the Ageing timer should be. The Ageing timer is used to break the deadlock of PCI-E bus transactions to resume normal system operations. The options are Disabled, 32 us, **128 us**, and 512 us.

#### **Intel® I/OAT**

Select Enabled to enable Intel I/OAT (I/O Acceleration Technology), which significantly reduces CPU overhead by leveraging CPU architectural capabilities and freeing up system resources for use of other tasks. The options are Disabled and **Enabled**.

#### **DCA Support**

When set to Enabled, this feature uses Intel's DCA (Direct Cache Access) Technology to improve data transfer efficiency. The options are **Enabled** and **Disabled**.

**MMCFG BASE**

This feature determines the lowest base address that can be assigned to PCI devices. The lower the address, the less system memory is available (for a 32-bit OS). The higher the address, the less resources are allocated to PCI devices. The options are 0x80000000, 0xA0000000, and **0xC0000000**.

**IIO 1 PCIe Port Bifurcation Control (Available when a PCI-E device is installed)**

This submenu configures the following Port-Bifurcation control settings which will determine how the PCI-Express lanes will be distributed between PCI-E ports.

**CPU1 Slot6 PCI-E 3.0 x8 Link Speed**

Use this item to select the desired type of PCI-Exp Generation support for the slot indicated above. The options are GEN1, GEN2, and **GEN3**.

**CPU1 Slot8/9 PCI-E 3.0 x16 Link Speed**

Use this item to select the desired type of PCI-Exp Generation support for the slot indicated above. The options are GEN1, GEN2, and **GEN3**.

**CPU1 Slot10/11 PCI-E 3.0 x16 Link Speed**

Use this item to select the desired type of PCI-Exp Generation support for the slot indicated above. The options are GEN1, GEN2, and **GEN3**.

**IIO 2 PCIe Port Bifurcation Control (Available when a PCI-E device is installed)**

This submenu configures the following Port-Bifurcation control settings which will determine how the PCI-Express lanes will be distributed between PCI-E ports..

**CPU2 Slot5 PCI-E 3.0 x8 Link Speed**

Use this item to select the desired type of PCI-Exp Generation support for the slot indicated above. The options are GEN1, GEN2, and **GEN3**.

**CPU2 Slot3/4 PCI-E 3.0 x16 Link Speed**

Use this item to select the desired type of PCI-Exp Generation support for the slot indicated above. The options are GEN1, GEN2, and **GEN3**.

**CPU2 Slot1/2 PCI-E 3.0 x16 Link Speed**

Use this item to select the desired type of PCI-Exp Generation support for the slot indicated above. The options are GEN1, GEN2, and **GEN3**.

## ►QPI Configuration

### Current QPI Link Speed

This item displays the speed of the QPI Link.

### Current QPI Link Frequency

This item displays the frequency of the QPI Link.

### Isoc

Select **Enabled** to enable Isochronous support to meet QoS (Quality of Service) requirements. This feature is especially important for Intel Virtualization technology support. The options are **Enabled** and **Disabled**.

### QPI (Quick Path Interconnect) Link Speed Mode

Use this feature to set data transfer rate for QPI Link connections. The options are **Fast** and **Slow**.

### QPI Link Frequency Select

Use this feature to set QPI Link frequency. The options are **Auto**, 6.4 GT/s, 7.2 GT/s, and 8.0 GT/s.

## ►DIMM Configuration

This section displays the following DIMM information.

### Memory Mode

This item displays the current memory mode.

### Current Memory Speed

This item displays the current memory speed.

### Mirroring

This item displays if memory mirroring is supported by the motherboard. Memory mirroring creates a duplicate copy of the data stored in the memory to enhance data security.

### Sparing

This item displays if memory sparing is supported by the motherboard. Memory sparing enhances system performance.

---

## ► DIMM Information

The status of a memory module is displayed as detected by the BIOS.

### Memory Mode

When Independent is selected, all DIMMs are available to the operating system. When Mirroring is selected, the motherboard maintains two identical copies of all data in memory for data backup. When Lockstep is selected, the motherboard uses two areas of memory to run the same set of operations in parallel. The options are **Independent**, Mirroring, and Lockstep.

### DRAM RAPL Mode

RAPL (Running Average Power Limit) is used to set the power consumption limit for a processor<sup>4</sup>. The options are DRAM RAPL MODE0, **DRAM RAPL MODE1**, and Disabled.

### DDR Speed

Use this feature to force a DDR3 memory module to run at a frequency other than what is specified by the manufacturer. The options are **Auto**, Force DDR3 800, Force DDR3 1066, Force DDR3 1333, Force DDR3 1600 and Force SPD.

### Channel Interleaving

Use this feature to select channel-interleaving mode for system memory modules. The options are **Auto**, 1 Way, 2 Way, 3, Way, and 4 Way.

### Rank Interleaving

Use this feature to select rank-interleaving mode for system memory modules. The options are **Auto**, 1 Way, 2 Way, 4, Way, and 8 Way.

### Patrol Scrub

Patrol Scrubbing is a process that allows the CPU to correct correctable memory errors detected on a memory module and send the correction to the requestor (the original source). When this item is set to Enabled, read-and-write will be performed every 16K cycles per cache line if there is no delay caused by internal processing. The options are **Enabled** and Disabled.

### Demand Scrub

Demand Scrubbing is a process that allows the CPU to correct correctable memory errors found on a memory module. When the CPU or I/O issues a demand-read command, and the read data from memory turns out to be a correctable error, the error is corrected and sent to the requestor (the original source). Memory is updated as well. Select Enabled to use Demand Scrubbing for ECC memory correction. The options are **Enabled** and Disabled.

**Data Scrambling**

Select Enabled to enable data scrambling to ensure data security and integrity. The options are Disabled and **Enabled**.

**Device Tagging**

Select Enabled to support device tagging which will allow the BIOS to tag a memory device that generates a stuck-bit or a hard error. The options are **Disabled** and Enabled.

**Thermal Throttling**

Throttling improves system reliability, availability and serviceability (RAS), and reduces CPU power consumption via automatic voltage control when the processor is idle. The options are Disabled and **CLTT** (Closed Loop Thermal Throttling).

**Double Refresh**

Select Enabled to support memory double-refreshing under high temperatures to ensure memory stability. The options are Disabled, **Auto**, and Enabled.

**► South Bridge**

This feature allows the user to configure the settings for the Intel PCH chip.

**PCH Information**

This feature displays the following PCH information.

**Name:** This item displays the name of the PCH chip.

**Stepping:** This item displays the PCH stepping.

**USB Devices:** This item displays the USB devices detected by the BIOS.

**All USB Devices**

Select Enabled to enable all USB ports and devices. The options are Disabled and **Enabled**.

**EHCI Controller 1, EHCI Controller 2 (Available when All USB Devices are set to Enabled)**

Select Enabled to enable EHCI (Enhanced Host Controller Interface) Controller 1 or Controller 2. The options are Disabled and **Enabled**.

**Legacy USB Support (Available when USB Functions is not Disabled)**

Select Enabled to support legacy USB devices. Select Auto to disable legacy support when legacy USB devices are not present. Select Disabled to make all USB

---

devices available for EFI (Extensive Firmware Interface) applications only. The settings are Disabled, **Enabled** and Auto.

### **Port 60/64 Emulation**

Select Enabled to enable I/O port 60h/64h emulation support for a legacy USB keyboard to be supported by the operating system that does not recognize a legacy USB device. The options are Disabled and **Enabled**.

### **EHCI Hand-Off**

This item is for operating systems that do not support Enhanced Host Controller Interface (EHCI) hand-off. When this feature is enabled, EHCI ownership change will be claimed by the EHCI driver. The options are **Disabled** and Enabled.

## **► SATA Configuration**

When this submenu is selected, the AMI BIOS automatically detects the presence of IDE or SATA devices and displays the following items.

**SATA Port0~SATA Port5:** The AMI BIOS displays the status of each SATA port as detected by the BIOS.

### **SATA Mode**

Use this feature to configure SATA mode for a selected SATA port. The options are Disabled, IDE Mode, **AHCI Mode**, and RAID Mode. The following items will be displayed pending on your selection:

#### **IDE Mode**

The following items are displayed when IDE Mode is selected:

#### **Serial-ATA (SATA) Controller 0~1**

Use this feature to activate or deactivate the SATA controller, and set the compatibility mode. The options are Disabled, Enhanced, and Compatible. The default for SATA Controller 0 is **Compatible**. The default of SATA Controller 1 is **Enhanced**.

#### **AHCI Mode**

The following items are displayed when the AHCI Mode is selected.

#### **Aggressive Link Power Management**

When this item is set to Enabled, the SATA AHCI controller manages the power usage of the SATA link. The controller will put the link in a low power mode during extended periods of I/O inactivity, and will return the link to

an active state when I/O activity resumes. The options are **Enabled** and **Disabled**.

#### **Port 0-5 Hot Plug**

Select **Enabled** to enable hot-plugging support for a particular port, which will allow the user to change a hardware component or device without shutting down the system. The options are **Enabled** and **Disabled**.

#### **Port 0-5 Staggered Spin Up**

Select **Enabled** to enable Staggered Spin-up support to prevent excessive power consumption caused by spinning-up of multiple devices simultaneously. The options are **Enabled** and **Disabled**.

### **RAID Mode**

The following items are displayed when RAID Mode is selected:

#### **SATA RAID Option ROM/UEFI Driver**

Use this feature to enable the onboard SATA Option ROM or EFI driver. The options are **Enabled** and **Disabled**.

#### **Port 0-5 Hot Plug**

Select **Enabled** to enable hot-plugging support for the particular port which will allow the user to replace a device without shutting down the system. The options are **Disabled** and **Enabled**.

## **► SCU (Storage Control Unit) Configuration**

### **Storage Controller Unit**

Select **Enabled** to support SCU storage devices. The options are **Disabled** and **Enabled**.

### **SCU RAID Option ROM/UEFI Driver**

Select **Enabled** to support the onboard SCU Option ROM to boot up the system via a storage device or from the UEFI driver. The options are **Disabled** and **Enabled**.

**SCU Port 0-SCU Port 3:** The AMI BIOS will automatically detect the onboard SCU devices and display the status of each SCU device as detected.

## ► PCIe/PCI/PnP Configuration

### Launch Storage OpROM Policy

Use this feature to select the Option ROM to boot the system when there are multiple Option ROMs available in the system. The options are UEFI only and **Legacy only**.

### PCI Latency Timer

Use this feature to set the latency timer of each PCI device installed on a PCI bus. Select 64 to set the PCI latency to 64 PCI clock cycles. The options are 32, 64, **96**, 128, 160, 192, 224 and 248.

### PERR# Generation

Select Enabled to allow a PCI device to generate a PERR number for a PCI Bus Signal Error Event. The options are Enabled and **Disabled**.

### SERR# Generation

Select Enabled to allow a PCI device to generate an SERR number for a PCI Bus Signal Error Event. The options are Enabled and **Disabled**.

### Maximum Payload

Select Auto to allow the system BIOS to automatically set the maximum payload value for a PCI-E device to enhance system performance. The options are **Auto**, 128 Bytes, 256 Bytes, 512 Bytes, 1024 Bytes, 2048 Bytes, and 4096 Bytes.

### Maximum Read Request

Select Auto to allow the system BIOS to automatically set the maximum Read Request size for a PCI-E device to enhance system performance. The options are **Auto**, 128 Bytes, 256 Bytes, 512 Bytes, 1024 Bytes, 2048 Bytes, and 4096 Bytes.

### ASPM Support

This feature allows the user to set the Active State Power Management (ASPM) level for a PCI-E device. Select Auto to allow the system BIOS to automatically set the ASPM level for the system. Select Disabled to disable ASPM support. The options are **Disabled** and Auto.

**Warning:** Enabling ASPM support may cause some PCI-E devices to fail!

### Above 4G Decoding (Available if the system supports 64-bit PCI decoding)

Select Enabled to decode a PCI device that supports 64-bit in the space above 4G Address. The options are **Enabled** and Disabled.

**CPU2 Slot1 PCI-E 3.0 x16 OPROM, CPU2 Slot2 PCI-E 3.0 x16 OPROM, CPU2 Slot3 PCI-E 3.0 x16 OPROM, CPU2 Slot4 PCI-E 3.0 x16 OPROM, CPU2 Slot5 PCI-E 3.0 x8 OPROM, CPU1 Slot6 PCI-E 3.0 x8 OPROM, PCI/PCIX/PCIe Slot7 OPROM, CPU1 Slot8 PCI-E 3.0 x16 OPROM, CPU1 Slot9 PCI-E 3.0 x16 OPROM, CPU1 Slot9 PCI-E 3.0 x16 OPROM, CPU1 Slot10 PCI-E 3.0 x16 OPROM, CPU1 Slot11 PCI-E 3.0 x16 OPROM,**

Select Enabled to enable Option ROM support to boot the computer using a device installed on the slot specified above. The options are **Enabled** and Disabled.

#### **Onboard LAN Option ROM Select**

Select iSCSI to use the iSCSI Option ROM to boot the computer from a SCSI drive. Select PXE (Preboot Execution Environment) to use an PXE Option ROM to boot the computer from a SCSI PXE drive. The options are iSCSI, FCoE, and **PXE**.

#### **Load Onboard LAN1 Option ROM, Load Onboard LAN2 Option ROM**

Select Enabled to enable the onboard LAN1/LAN2 Option ROM. This is to boot the computer using a network device installed in a LAN port specified. The default setting for LAN1 Option ROM is **Enabled**, and the default setting for LAN2 Option ROM is **Disabled**.

#### **VGA Priority**

This feature allows the user to select the graphics adapter to be used as the primary boot device. The options are **Onboard** and Offboard.

#### **Network Stack**

Select Enabled enable PXE (Preboot Execution Environment) or UEFI (Unified Extensible Firmware Interface) for network stack support. The options are Enabled and **Disabled**.

#### **IPv4 PXE Support (Available when the item above-Network Stack is set to Enabled)**

Set this item to Enabled to activate IPv4 PXE Support. The options are **Enabled** and Disabled.

### **► Super IO Configuration**

**Super IO Chip:** This item displays the Super IO chip used in the motherboard.

#### **WPCM450 Serial Port Attribute**

If this item is set to COM/SOL, the port specified above will be used for normal operation. Select BMC for the port specified above to be used for system debugging only. The options are **COM/SOL** and BMC.

---

## ► Serial Port 1 Configuration

### Serial Port

Select Enabled to enable a serial port specified by the user. The options are **Enabled** and Disabled.

### Device Settings

This item displays the settings of Serial Port 1.

### Change Settings

This option specifies the base I/O port address and the Interrupt Request address of Serial Port 1. Select Disabled to prevent the serial port from accessing any system resources. When this option is set to Disabled, the serial port becomes unavailable. The options are **Auto**, IO=3F8h, IRQ=4, IO=3F8h, IRQ=3; IO=2F8h, IRQ=3; IO=3E8h, IRQ=5; IO=2E8h, IRQ=7; IO=3F8h, IRQ=3, 4, 5, 6, 7, 10, 11, 12; IO=2F8h, IRQ=3, 4, 5, 6, 7, 10, 11, 12; IO=3E8h, IRQ=3, 4, 5, 6, 7, 10, 11, 12; IO=2E8h, IRQ=3, 4, 5, 6, 7, 10, 11, 12.

### Device Mode

Use this feature to select the desired mode for a serial port specified. The options are **Normal** and High Speed.

## ► Serial Port 2 Configuration

### SOL (Serial-Over-LAN) Serial Port

Select Enabled to enable a serial port specified by the user. The options are **Enabled** and Disabled.

### Device Settings

This item displays the settings of Serial Port 2.

### SOL Change Settings

This option specifies the base I/O port address and the Interrupt Request address of Serial Port 2. Select Disabled to prevent the serial port from accessing any system resources. When this option is set to Disabled, the serial port becomes unavailable. The options are **Auto**, IO=3F8h, IRQ=4; IO=3F8h, IRQ=3; IO=2F8h, IRQ=3; IO=3E8h, IRQ=5; IO=2E8h, IRQ=7; IO=3F8h, IRQ=3, 4, 5, 6, 7, 10, 11, 12; IO=2F8h, IRQ=3, 4, 5, 6, 7, 10, 11, 12; IO=3E8h, IRQ=3, 4, 5, 6, 7, 10, 11, 12; IO=2E8h, IRQ=3, 4, 5, 6, 7, 10, 11, 12.

### SOL Device Mode

Use this feature to select the desired mode for a serial port specified. The options are **Normal** and High Speed.

## ► Serial Port Console Redirection

### COM1/SOL

These two submenus allow the user to configure the following console redirection settings for a COM Port specified by the user.

#### COM1/SOL Console Redirection

Select Enabled to use a COM Port selected by the user for console redirection. The options are Enabled and Disabled. The default setting for COM1 is **Disabled**, and for COM2 is **Enabled**.

## ► Console Redirection Settings

This feature allows the user to specify how the host computer will exchange data with the client computer, which is the remote computer used by the user.

### Terminal Type

This feature allows the user to select the target terminal emulation type for console redirection. Select VT100 to use the ASCII Character set. Select VT100+ to add color and function key support. Select ANSI to use the Extended ASCII Character Set. Select VT-UTF8 to use UTF8 encoding to map Unicode characters into one or more bytes. The options are ANSI, VT100, **VT100+**, and VT-UTF8.

### Bits Per second

Use this feature to set the transmission speed for a serial port used in console redirection. Make sure that the same speed is used in the host computer and the client computer. A lower transmission speed may be required for long and busy lines. The options are 9600, 19200, 38400, 57600 and **115200** (bits per second).

### Data Bits

Use this feature to set the data transmission size for Console redirection. The options are 7 Bits and **8 Bits**.

### Parity

A parity bit can be sent along with regular data bits to detect data transmission errors. Select Even if the parity bit is set to 0, and the number of 1's in data bits is even. Select Odd if the parity bit is set to 0, and the number of 1's in data bits is odd. Select None if you do not want to send a parity bit with your data bits

in transmission. Select **Mark** to add a mark as a parity bit to be sent along with the data bits. Select **Space** to add a Space as a parity bit to be sent with your data bits. The options are **None**, Even, Odd, Mark and Space.

### **Stop Bits**

A stop bit indicates the end of a serial data packet. Select 1 Stop Bit for standard serial data communication. Select 2 Stop Bits if slower devices are used. The options are **1** and **2**.

### **Flow Control**

This feature allows the user to set the flow control for Console redirection to prevent data loss caused by buffer overflow. Send a "Stop" signal to stop sending data when the receiving buffer is full. Send a "Start" signal to start sending data when the receiving buffer is empty. The options are **None** and Hardware RTS/CTS.

### **VT-UTF8 Combo Key Support**

Select **Enabled** to enable VT-UTF8 Combination Key support for ANSI/VT100 terminals. The options are **Enabled** and **Disabled**.

### **Recorder Mode**

Select **Enabled** to capture the data displayed on a terminal and send it as text messages to a remote server. The options are **Disabled** and **Enabled**.

### **Resolution 100x31**

Select **Enabled** for extended-terminal resolution support. The options are **Disabled** and **Enabled**.

### **Legacy OS Redirection Resolution**

Use this feature to select the number of rows and columns used in Console redirection for legacy OS support. The options are 80x24 and **80x25**.

### **Putty KeyPad**

This feature selects Function Keys and KeyPad settings for Putty, which is a terminal emulator designed for the Windows OS. The options are **VT100**, LINUX, XTERMR6, SCO, ESCN, and VT400.

### **Redirection After BIOS Post**

Use this feature to enable or disable legacy console redirection after BIOS POST. When set to **Bootloader**, legacy console redirection is disabled before booting the OS. When set to **Always Enable**, legacy console redirection remains enabled when booting the OS. The options are **Always Enable** and **Bootloader**.

### **Serial Port for Out-of-Band Management/Windows Emergency Management Services (EMS)**

The submenu allows the user to configure console redirection settings to support Out-of-Band Serial Port management.

#### **Console Redirection**

Select Enabled to use a COM Port selected by the user for console redirection. The options are Enabled and **Disabled**.

#### **► Console Redirection Settings (for EMS)**

This feature allows the user to specify how the host computer will exchange data with the client computer, which is the remote computer used by the user.

#### **Out-of-Band Management Port**

The feature selects a serial port used by the Microsoft Windows Emergency Management Services (EMS) to communicate with a remote server. The options are **COM1** and SOL.

#### **Terminal Type**

This feature allows the user to select the target terminal emulation type for console redirection. Select VT100 to use the ASCII character set. Select VT100+ to add color and function key support. Select ANSI to use the extended ASCII character set. Select VT-UTF8 to use UTF8 encoding to map Unicode characters into one or more bytes. The options are ANSI, VT100, **VT100+**, and VT-UTF8.

#### **Bits Per Second**

This item sets the transmission speed for a serial port used in console redirection. Make sure that the same speed is used in the host computer and the client computer. A lower transmission speed may be required for long and busy lines. The options are 9600, 19200, 57600, and **115200** (bits per second).

#### **Flow Control**

This feature allows the user to set the flow control for console redirection to prevent data loss caused by buffer overflow. Send a "Stop" signal to stop sending data when the receiving buffer is full. Send a "Start" signal to start sending data when the receiving buffer is empty. The options are **None**, Hardware RTS/CTS, and Software Xon/Xoff.

#### **Data Bits, Parity, Stop Bits**

The setting for each of these items is displayed.

## ► ACPI Settings

Use this feature to configure Advanced Configuration and Power Interface (ACPI) power management settings for your system.

### ACPI Sleep State

Use this feature to select the ACPI State when the system is in the sleep mode. Select S1 (CPU Stop Clock) to erase all CPU caches and stop executing instructions. Power to the CPU(s) and RAM is maintained, and RAM is refreshed. Select Suspend Disabled to use power-reduced mode. Power will only be supplied to limited components (such as RAMs) to maintain the most critical functions of the system. The options are **S1 (CPU Stop Clock)**, and Suspend Disabled.

### NUMA (NON-Uniform Memory Access)

This feature enables the Non-Uniform Memory Access ACPI support. The options are **Enabled** and Disabled.

### High Precision Event Timer

Select Enabled to activate the High Precision Event Timer (HPET) that produces periodic interrupts at a much higher frequency than a real-time Clock (RTC) does in synchronizing multimedia streams, providing smooth playback, reducing the dependency on other timestamp calculation devices, such as an x86 RDTSC Instruction embedded in the CPU. The High Precision Event Timer is used to replace the 8254 Programmable Interval Timer. The options are **Enabled** and Disabled.

## ► Trusted Computing (Available when a TPM device is detected by the BIOS)

### Configuration

#### TPM Support

Select Enabled on this item and enable the TPM jumper on the motherboard to enable TPM support to improve data integrity and network security. The options are **Enabled** and Disabled.

#### TPM State

Select Enabled to enable TPM security settings to improve data integrity and network security. The options are Disabled and **Enabled**.

### Pending Operation

Use this item to schedule an operation for the security device. The options are **None**, Enable Take Ownership, Disable Take Ownership, and TPM Clear.

**Note:** During restart, the computer will reboot in order to execute the pending operation and change the state of the security device.

**Current Status Information:** This item displays the information regarding the current TPM status.

### TPM Enable Status

This item displays the status of TPM Support to indicate if TPM is currently enabled or disabled.

### TPM Active Status

This item displays the status of TPM Support to indicate if TPM is currently active or deactivated.

### TPM Owner Status

This item displays the status of TPM Ownership.

## ► Intel TXT (LT-SX) Configuration

### Intel TXT (LT-SX) Hardware Support

This feature indicates if the following hardware components support the Intel Trusted Execution Technology.

**CPU:** TXT (Trusted Execution Technology) Feature

**Chipset:** TXT (Trusted Execution Technology) Feature

### Intel TXT (LT-SX) Configuration

This feature displays the following TXT configuration setting.

**TXT (LT-SX) Support:** This item indicates if the Intel TXT support is enabled or disabled. The default setting is **Disabled**.

**Note:** Be sure to format your TPM module before enabling TXT (LT-SX) support for this feature to work properly.

### Intel TXT (LT-SX) Dependencies

For Trusted Execution Technology to work properly, be sure to enable the features displayed below:

**VT-d Support:** Intel Virtualization Technology with Direct I/O support

---

**VT Support:** Intel Virtualization Technology support

**TPM Support:** Trusted Platform support

**TPM State:** Trusted Platform state

## ► ME Subsystem

This feature displays the following ME Subsystem Configuration settings.

- **ME BIOS Interface Version**
- **ME Version**

## 7-4 Event Logs

Use this feature to configure Event Log settings.

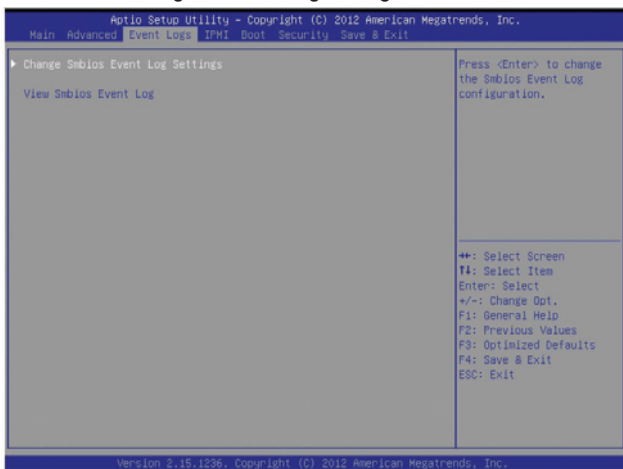

### ► Change SMBIOS Event Log Settings

This feature allows the user to configure SMBIOS Event settings.

#### Enabling/Disabling Options

##### SMBIOS Event Log

Select Enabled to enable SMBIOS (System Management BIOS) Event Logging during system boot. The options are **Enabled** and Disabled.

##### Runtime Error Logging Support

Select Enabled to support Runtime Error Logging. The options are **Enabled** and Disabled.

### **Memory Correctable Error Threshold**

This feature allows the user to enter the threshold value for correctable memory errors. The default setting is **10**.

### **PCI Error Logging Support**

Select Enabled to support error event logging for PCI slots. The options are Enabled and **Disabled**.

### **Erasing Settings**

#### **Erase Event Log**

Select Enabled to erase the SMBIOS (System Management BIOS) Event Log, which is completed before an event logging is initialized upon system reboot. The options are **No**, Yes, next reset, and Yes, every reset.

#### **When Log is Full**

Select Erase Immediately to immediately erase SMBIOS error event logs that exceed the limit when the SMBIOS event log is full. Select Do Nothing for the system to do nothing when the SMBIOS event log is full. The options are **Do Nothing** and Erase Immediately.

### **SMBIOS Event Log Standard Settings**

#### **Log System Boot Event**

Select Enabled to log system boot events. The options are **Disabled** and Enabled.

#### **MECI (Multiple Event Count Increment)**

Enter the increment value for the multiple event counter. Enter a number between 1 to 255. The default setting is **1**.

#### **METW (Multiple Event Count Time Window)**

This item allows the user to decide how long (in minutes) should the multiple event counter wait before generating a new event log. Enter a number between 0 to 99. The default setting is **60**.

#### **View SMBIOS Event Log**

This item allows the user to view the event in the SMBIOS event log. Select this item and press <Enter> to view the status of an event in the log.

- Date
- Time
- Error Code

- Severity

## 7-5 IPMI

Use this feature to configure Intelligent Platform Management Interface (IPMI) settings.

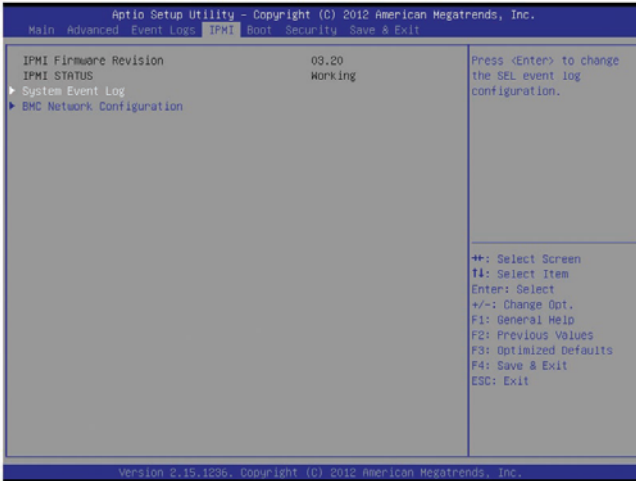

### IPMI Firmware Revision

This item indicates the IPMI firmware revision used in your system.

### IPMI Status

This item indicates the status of the IPMI firmware installed in your system.

## ► System Event Log

### Enabling/Disabling Options

#### SEL Components

Select Enabled for all system event logging at bootup. The options are **Enabled** and Disabled.

### Erasing Settings

#### Erase SEL

Select Yes, On next reset to erase all system event logs upon next system reboot.  
 Select Yes, On every reset to erase all system event logs upon each system reboot.

Select No to keep all system event logs after each system reboot. The options are **No**, Yes, On next reset, and Yes, On every reset.

#### **When SEL is Full**

This feature allows the user to decide what the BIOS should do when the system event log is full. Select Erase Immediately to erase all events in the log when the system event log is full. The options are **Do Nothing** and Erase Immediately.

### **►BMC Network Configuration**

The following information will be displayed.

#### **LAN Channel 1**

##### **IPMI LAN Selection**

##### **IPMI Network Link Status**

##### **Update IPMI LAN Configuration**

This feature allows the BIOS to implement any IP/MAC address changes at the next system boot. If the option is set to Yes, any changes made to the settings below will take effect when the system is rebooted. The options are **No** and Yes.

##### **Configuration Address Source**

This feature allows the user to select the source of the IP address for this computer. If Static is selected, you will need to know the IP address of this computer and enter it to the system manually in the field. If DHCP is selected, the BIOS will search for a DHCP (Dynamic Host Configuration Protocol) server in the network that it is attached to and request the next available IP address for this computer. The options for are **DHCP** and Static. The following items are assigned IP addresses automatically if DHCP is selected, or can be configured manually if Static is selected.

##### **Station IP Address**

This item displays the Station IP address for this computer. This should be in decimal and in dotted quad form (i.e., 192.168.10.253).

##### **Subnet Mask**

This item displays the sub-network that this computer belongs to. The value of each three-digit number separated by dots should not exceed 255.

##### **Station MAC Address**

This item displays the Station MAC address for this computer. Mac addresses are 6 two-digit hexadecimal numbers.

## Gateway IP Address

This item displays the Gateway IP address for this computer. This should be in decimal and in dotted quad form (i.e., 192.168.10.253).

## 7-6 Boot

This submenu allows the user to configure the following boot settings for the system.



## Boot Option Priority

### 1st Boot Device/2nd Boot Device/3rd Boot Device/4th Boot Device/5th Boot Device/6th Boot Device/

Use these items to specify the sequence of boot device priority.

#### ▶ Delete Driver Option

This feature allows the user to delete a previously defined boot device from which the systems boots during startup.

#### Delete Boot Drive Option

Select a bootable drive to remove it from the boot drive list so that the system can no longer boot from this drive.

#### ▶ Network Device BBS Priorities

- 1st Device

▶ **UEFI OS Boot Priorities**

- 1st Device

## 7-7 Security

This menu allows the user to configure the following security settings for the system.

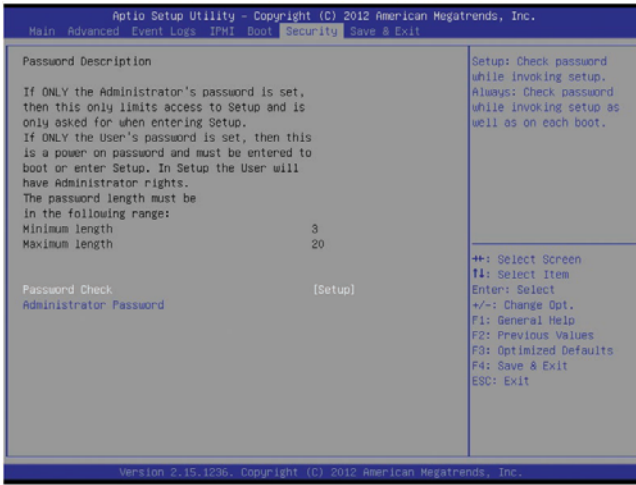

### Password Check

Use this feature to determine when a password entry is required. Select Setup for the user to enter a password only when entering setup. Select Always for the user to enter a password upon entering setup and at each system boot. The options are **Setup** and Always.

### Administrator Password

Use this feature to set the Administrator password which is required to enter the BIOS setup utility. The length of the password should be from 3 characters to 20 characters long.

## 7-8 Save & Exit

This submenu allows the user to configure the Save and Exit settings for the system.



### Discard Changes and Exit

Select this option to quit the BIOS setup menu without making any permanent changes to the system configuration, and reboot the computer. Select Discard Changes and Exit, and press <Enter>. When the dialog box appears, asking you if you want to exit the BIOS setup without saving, select **Yes** to quit BIOS without saving the changes, or select No to quit the BIOS and save changes.

### Save Changes and Reset

When you have completed the system setup changes, select this option to save the changes and reboot the computer so that the new system configuration settings can take effect. Select Save Changes and Exit, and press <Enter>. When the dialog box appears, asking you if you want to exit the BIOS setup without saving, select **Yes** to quit BIOS without saving the changes, or select No to quit the BIOS and save changes.

### Save Options

#### Save Changes

Select this option and press <Enter> to save all changes you've done so far and return to the AMI BIOS utility Program. When the dialog box appears, asking you if you want to save configuration, select **Yes** to save the changes, or select No to return to the BIOS without making changes.

**Discard Changes**

Select this feature and press <Enter> to discard all the changes and return to the BIOS setup. When the dialog box appears, asking you if you want to load previous values, select **Yes** to load the values previously saved, or select **No** to keep the changes you've made so far.

**Restore Optimized Defaults**

Select this feature and press <Enter> to load the optimized default settings that help optimize system performance. When the dialog box appears, asking you if you want to load optimized defaults, select **Yes** to load the optimized default settings, or select **No** to abandon optimized defaults.

**Save as User Defaults**

Select this feature and press <Enter> to save the current settings as the user's defaults. When the dialog box appears, asking you if you want to save values as user's defaults, click **Yes** to save the current values as user's default settings, or click **No** to keep the defaults previously saved as the user's defaults.

**Restore User Defaults**

Select this feature and press <Enter> to load the user's defaults previously saved in the system. When the dialog box appears, asking you if you want to restore user's defaults, select **Yes** to restore the user's defaults previously saved in the system, or select **No** to abandon the user's defaults that were previously saved.

**Boot Override**

This feature allows the user to override the Boot Option Priorities setting in the Boot menu, and instead immediately boot the system with one of the listed devices. This is a one-time override.

IBA XE Slot 0F00 v2304

UEFI: Built-in EFI Shell

## Notes

## Appendix A

### BIOS Error Beep Codes

During the POST (Power-On Self-Test) routines, which are performed at each system boot, errors may occur.

**Non-fatal errors** are those which, in most cases, allow the system to continue to boot. The error messages normally appear on the screen.

**Fatal errors** will not allow the system to continue with bootup procedure. If a fatal error occurs, you should consult with your system manufacturer for possible repairs.

These fatal errors are usually communicated through a series of audible beeps. The numbers on the fatal error list correspond to the number of beeps for the corresponding error.

X9 Motherboard BIOS Error Beep Codes		
Beep Code/LED	Error Message	Description
1 beep	Refresh	Ready to boot
5 short beeps + 1 long beep	Memory error	No memory detected in the system
5 beeps	No Con-In or No Con-Out devices	Con-In includes USB or PS/2 keyboard, PCI or Serial Console Redirection, IPMI KVM or SOL.  Con-Out includes Video Controller, PCI or Serial Console Redirection, IPMI SOL.
X9 IPMI Error Codes		
1 Continuous Beep	System OH	System Overheat

**Notes**

# Appendix B

## System Specifications

### Processors

Two E5-4600 series processors in Socket R LGA 2011 type sockets

**Note:** please refer to our website for details on supported processors.

### Chipset

C602 chipset

### BIOS

16MB SPI Flash EEPROM with AMI® BIOS

### Memory Capacity

Twenty four DIMM slots supporting up to 1.5 TB of LRDIMM. 768 GB of RDIMM or 128 GB of ECC/non-ECC UDIMM DDR3-1600/1333/1066/800 memory.

**Note:** Refer to Section 5-5 for details on installation. Check the Supermicro website ([www.supermicro.com](http://www.supermicro.com)) for the latest memory support information.

### SATA Drive Bays

Twenty-four hot-swap drive bays to house 2.5" SATA drives.

### GPUs (Graphics Processing Units)

A total of eight GPUs are supported (true PCI-E 3.0 x16 signal)

### PCI Expansion

Eight PCI Express 3.0 x16 slots, two PCI Express x8 slots (in x16 slots) and one PCI Express 2.0 x4 (in a x16 slot) slot

### Serverboard

4027GR-TR: X9DRG-OF, 4027GR-TRT X9DRG-OTF serverboard

(proprietary form factor)

Dimensions: 17 x 19 in. (43.2 x 48.3 mm)

## Chassis

SC418GTS-R3200B (4U rackmount)

Dimensions: (WxHxD) 7 x 17.2 x 29 in. (178 x 437 x 737 mm)

## Weight

Gross (Bare Bone): 100 lbs. (45.4 kg.)

## System Cooling

The system has eight 9-cm hot-swappable cooling fans

## System Input Requirements

AC Input Voltage: 100-240VAC auto-range

Rated Input Current: 1000W: 100-127V/12.9A, 1600W: 200-240V/9.5A

Rated Input Frequency: 50 to 60 Hz

## Power Supply

Rated Output Power: 1000W/1600W (Part# PWS-1K66P-1R)

Rated Output Voltages: 1000W: +12V (82A), +12Vsb (2A), 1600W: +12V (132A),  
+12Vsb (2A)

## Operating Environment

Operating Temperature: 10° to 35° C (50° to 95° F)

Non-operating Temperature: -40° to 70° C (-40° to 158° F)

Operating Relative Humidity: 8% to 90% (non-condensing)

Non-operating Relative Humidity: 5 to 95% (non-condensing)

## Regulatory Compliance

Electromagnetic Emissions: FCC Class A, EN 55022 Class A, EN 61000-3-2/-3-3, CISPR 22 Class A

Electromagnetic Immunity: EN 55024/CISPR 24, (EN 61000-4-2, EN 61000-4-3, EN 61000-4-4, EN 61000-4-5, EN 61000-4-6, EN 61000-4-8, EN 61000-4-11)

Safety: CSA/EN/IEC/UL 60950-1 Compliant, UL or CSA Listed (USA and Canada), CE Marking (Europe)

California Best Management Practices Regulations for Perchlorate Materials:  
This Perchlorate warning applies only to products containing CR (Manganese Dioxide) Lithium coin cells. "Perchlorate Material-special handling may apply.  
See [www.dtsc.ca.gov/hazardouswaste/perchlorate](http://www.dtsc.ca.gov/hazardouswaste/perchlorate)" for further details.

## Notes

(continued from front)

The products sold by Supermicro are not intended for and will not be used in life support systems, medical equipment, nuclear facilities or systems, aircraft, aircraft devices, aircraft/emergency communication devices or other critical systems whose failure to perform be reasonably expected to result in significant injury or loss of life or catastrophic property damage. Accordingly, Supermicro disclaims any and all liability, and should buyer use or sell such products for use in such ultra-hazardous applications, it does so entirely at its own risk. Furthermore, buyer agrees to fully indemnify, defend and hold Supermicro harmless for and against any and all claims, demands, actions, litigation, and proceedings of any kind arising out of or related to such ultra-hazardous use or sale.