

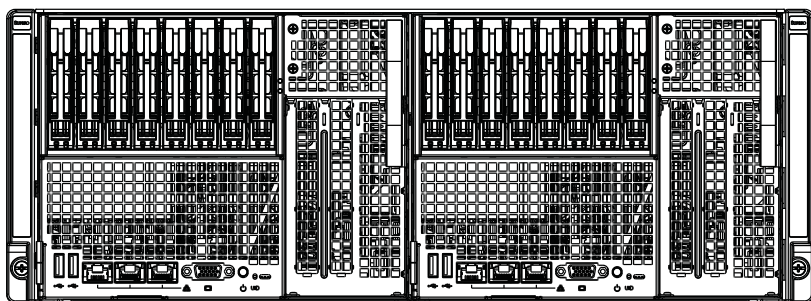

SUPERSERVER®

F648G2-FC0+
F648G2-FC0PT+



USER'S MANUAL

Revision 1.0

The information in this User's Manual has been carefully reviewed and is believed to be accurate. The vendor assumes no responsibility for any inaccuracies that may be contained in this document, makes no commitment to update or to keep current the information in this manual, or to notify any person or organization of the updates. **Please Note: For the most up-to-date version of this manual, please see our web site at www.supermicro.com.**

Super Micro Computer, Inc. ("Supermicro") reserves the right to make changes to the product described in this manual at any time and without notice. This product, including software and documentation, is the property of Supermicro and/or its licensors, and is supplied only under a license. Any use or reproduction of this product is not allowed, except as expressly permitted by the terms of said license.

IN NO EVENT WILL SUPERMICRO BE LIABLE FOR DIRECT, INDIRECT, SPECIAL, INCIDENTAL, SPECULATIVE OR CONSEQUENTIAL DAMAGES ARISING FROM THE USE OR INABILITY TO USE THIS PRODUCT OR DOCUMENTATION, EVEN IF ADVISED OF THE POSSIBILITY OF SUCH DAMAGES. IN PARTICULAR, SUPERMICRO SHALL NOT HAVE LIABILITY FOR ANY HARDWARE, SOFTWARE, OR DATA STORED OR USED WITH THE PRODUCT, INCLUDING THE COSTS OF REPAIRING, REPLACING, INTEGRATING, INSTALLING OR RECOVERING SUCH HARDWARE, SOFTWARE, OR DATA.

Any disputes arising between manufacturer and customer shall be governed by the laws of Santa Clara County in the State of California, USA. The State of California, County of Santa Clara shall be the exclusive venue for the resolution of any such disputes. Super Micro's total liability for all claims will not exceed the price paid for the hardware product.

FCC Statement: This equipment has been tested and found to comply with the limits for a Class A digital device pursuant to Part 15 of the FCC Rules. These limits are designed to provide reasonable protection against harmful interference when the equipment is operated in a commercial environment. This equipment generates, uses, and can radiate radio frequency energy and, if not installed and used in accordance with the manufacturer's instruction manual, may cause harmful interference with radio communications. Operation of this equipment in a residential area is likely to cause harmful interference, in which case you will be required to correct the interference at your own expense.

California Best Management Practices Regulations for Perchlorate Materials: This Perchlorate warning applies only to products containing CR (Manganese Dioxide) Lithium coin cells. "Perchlorate Material-special handling may apply. See www.dtsc.ca.gov/hazardouswaste/perchlorate"

WARNING: Handling of lead solder materials used in this product may expose you to lead, a chemical known to the State of California to cause birth defects and other reproductive harm.

Revision 1.0

Release Date: April 29, 2015

Unless you request and receive written permission from Super Micro Computer, Inc., you may not copy any part of this document.

Information in this document is subject to change without notice. Other products and companies referred to herein are trademarks or registered trademarks of their respective companies or mark holders.

Copyright © 2015 by Super Micro Computer, Inc.

All rights reserved.

Printed in the United States of America

Preface

About This Manual

This manual is written for professional system integrators and PC technicians. It provides information for the installation and use of the FatTwin™ F648G2-FC0+/FC0PT+ servers. Installation and maintenance should be performed by experienced technicians only.

The FatTwin F648G2-FC0+/FC0PT+ is a high-end server based on the F442BG-R2K04BP 4U rackmount chassis and a dual processor X10DRFF-CG/CTG serverboard. All models have two serverboard nodes each with an IPMI LAN port and up to eight (8) 2.5" HDD drives per node. The F648G2-FC0PT+ server uses 10-Gigabit LAN ports, while the F648G2-FC0+ server uses only Gigabit LAN ports.

Manual Organization

Chapter 1: Introduction

The first chapter provides a checklist of the main components included with the server system and describes the main features of the X10DRFF-CG/CTG serverboards and the F442BG-R2K04BP chassis.

Chapter 2: Server Installation

This chapter describes the steps necessary to install the FatTwin F648G2-FC0+/FC0PT+ servers into a rack and check out the server configuration prior to powering up the system. If your server was ordered without processor and memory components, this chapter will refer you to the appropriate sections of the manual for their installation.

Chapter 3: System Interface

Refer here for details on the system interface, which includes the functions and information provided by the control panel on the chassis as well as other LEDs located throughout the system.

Chapter 4: Standardized Warning Statements for AC Systems

You should thoroughly familiarize yourself with this chapter for a general overview of safety precautions that should be followed when installing and servicing the FatTwin F648G2-FC0+/FC0PT+ servers.

Chapter 5: Advanced Serverboard Setup

Chapter 5 provides detailed information on the X10DRFF-CG/CTG serverboards, including the locations and functions of connections, headers and jumpers. Refer to this chapter when adding or removing processors or main memory and when reconfiguring the serverboard.

Chapter 6: Advanced Chassis Setup

Refer to Chapter 6 for detailed information on the F442BG-R2K04BP server chassis. You should follow the procedures given in this chapter when installing, removing or reconfiguring SATA or peripheral drives and when replacing system power supply units and cooling fans.

Chapter 7: BIOS

The BIOS chapter includes an introduction to BIOS and provides detailed information on running the CMOS Setup Utility.

Appendix A: BIOS Error Beep Codes

Appendix B: System Specifications

Notes

Table of Contents

Chapter 1 Introduction

1-1	Overview	1-1
1-2	Serverboard Features	1-2
	Processors	1-2
	Memory	1-2
	Serial ATA	1-3
	SAS	1-3
	PCI Expansion Slots	1-3
	Onboard Controllers/Ports	1-3
	Graphics Controller	1-3
	Aspeed AST2400 Controller	1-4
	Other Features Supported by the Aspeed AST2400 Controller	1-4
	Power Supply	1-5
	Super I/O	1-5
1-3	Server Chassis Features	1-5
	System Power	1-5
	SAS/SATA Subsystem	1-5
	I/O Ports	1-5
	Cooling System	1-6
	Air Shrouds	1-6
	Mounting Rails	1-6
1-4	Advanced Power Management	1-6
	Intel® Intelligent Power Node Manager (NM)	1-6
	Manageability Engine (ME)	1-6
1-5	Contacting Supermicro	1-8
1-6	Fat Twin: System Nodes	1-9
	Nodes	1-9
	System Power	1-9
	SAS/SATA Backplane/Drives	1-9

Chapter 2 Server Installation

2-1	Overview	2-1
2-2	Unpacking the System	2-1
2-3	Preparing for Setup	2-1
2-4	Warnings and Precautions	2-2
	Choosing a Setup Location	2-2
	Rack Precautions	2-2

Server Precautions.....	2-2
Rack Mounting Considerations	2-3
Ambient Operating Temperature	2-3
Reduced Airflow	2-3
Mechanical Loading	2-3
Circuit Overloading.....	2-3
Reliable Ground	2-4
2-5 Rack Mounting Instructions.....	2-4
Identifying the Sections of the Rack Rails.....	2-4
Adjusting the Rails	2-5
Locking Tabs	2-5
Installing the Rails on a Rack.....	2-6
Chassis Installation	2-7
2-6 Checking the Serverboard Setup.....	2-8
2-7 Checking the Drive Bay Setup.....	2-9
Chapter 3 System Interface	
3-1 Overview	3-1
3-3 F442BG Front I/O Control Panel	3-1
Power	3-2
UID	3-2
3-4 Drive Carrier LEDs.....	3-2
Chapter 4 Standardized Warning Statements for AC Systems	
4-1 About Standardized Warning Statements.....	4-1
Warning Definition	4-1
Installation Instructions.....	4-4
Circuit Breaker	4-5
Power Disconnection Warning	4-6
Equipment Installation.....	4-8
Restricted Area.....	4-9
Battery Handling.....	4-10
Redundant Power Supplies	4-12
Backplane Voltage	4-13
Comply with Local and National Electrical Codes	4-14
Product Disposal	4-15
Hot Swap Fan Warning.....	4-16
Power Cable and AC Adapter	4-18

Chapter 5 Advanced Motherboard Setup

5-1	Handling the Motherboard	5-1
	Precautions	5-1
	Unpacking	5-1
5-2	Connecting Cables	5-2
	Connecting Data Cables	5-2
5-3	Control Panel Connectors and I/O Ports	5-2
5-4	Processor and Heatsink Installation.....	5-3
	Installing a Passive CPU Heatsink	5-7
	Removing the Passive Heatsink	5-8
5-5	Installing Memory	5-9
	Removing Memory Modules	5-9
	Memory Support.....	5-10
5-6	Motherboard Details.....	5-12
5-7	Connector Definitions.....	5-15
5-8	Jumper Settings	5-19
	Explanation of Jumpers	5-19
5-9	Onboard Indicators.....	5-22
5-10	Serial ATA and SAS Connections	5-24
5-11	Installing Drivers.....	5-25
	SuperDoctor 5	5-26
5-12	Serverboard Battery	5-28

Chapter 6 Advanced Chassis Setup

6-1	Static-Sensitive Devices.....	6-1
	Precautions	6-1
	Unpacking	6-1
6-2	Control Panel	6-2
6-3	Removing the Power Cord.....	6-3
6-4	Removing Nodes from the Chassis	6-3
6-5	Installing and Removing Hard Drives	6-4
	Removing Hard Drives from the Front of the Node.....	6-5
	Installing 2.5" Hard Drives into the Drive Carriers.....	6-6
6-6	Node Configuration	6-8
	Overview of the Node	6-8
6-7	Removing the Node Cover.....	6-9
6-8	Removing and Installing the Backplane.....	6-10
	Removing the Backplane	6-10
	Installing the Backplane	6-11
6-9	Power Adapter Board Replacement.....	6-12

6-10	Installing the Serverboard	6-16
	Compatible Motherboards.....	6-16
	Permanent and Optional Standoffs.....	6-16
6-11	Installing Front and Rear Expansion Cards.....	6-18
	PCI-E Slot Setup.....	6-18
	Installing an Expansion Card	6-19
6-12	Installing Internal GPUs	6-20
	Installing Front GPUs into the GPU Bracket	6-20
	Installing a Front GPU into the Node	6-21
	Preparation Before Installing Rear GPUs into the Node	6-21
	Installing the Rear 10.5" GPU into the Node	6-22
6-13	Installing the Air Shrouds	6-23
	Air Shrouds	6-23
6-14	Checking the Airflow	6-24
	Installation Complete.....	6-24
6-15	Replacing Exhaust Fans	6-25
6-16	Replacing the Power Supply.....	6-26
	Power Supply Replacement.....	6-26

Chapter 7 BIOS

7-1	Introduction.....	7-1
	Starting BIOS Setup Utility.....	7-1
	How To Change the Configuration Data	7-1
	Starting the Setup Utility	7-2
7-2	Main Setup	7-2
7-3	Advanced Setup Configurations.....	7-3
7-4	Event Logs	7-41
7-5	IPMI	7-43
7-6	Security Settings	7-45
7-7	Boot Settings.....	7-46
7-8	Save & Exit	7-48

Appendix A System Specifications

Notes

Chapter 1

Introduction

1-1 Overview

The FatTwin F648G2-FC0+/FC0PT+ is a high-end server comprised of two main subsystems: the F442BG-R2K04BP 4U server chassis and the X10DRFF-CG/CTG dual processor serverboard in two hot-swap nodes. Each node in the SCF442BG model supports eight 2.5" hard drives (sixteen total), and six internal GPUs per node (12 total).

Please refer to our web site for information on operating systems that have been certified for use with the system (www.supermicro.com).

In addition to the serverboard and chassis, various hardware components have been included with the FatTwin F648G2-FC0+/FC0PT+ server, as listed below:

- Four (4) 2U passive CPU heat sinks with Narrow ILM (SNK-P0048PS)
- Power Adapter:
 - Four (4) power backplanes for GPU (BPN-ADP-4UGPU-O-P)
 - Four (4) power backplanes (BPN-ADP-F418L-O-P)
- SAS/SATA Backplane and accessories:
 - Two (2) SDD/HDD backplanes (BPN-SAS3-I28A)
 - Sixteen (16) 2.5" HDD hot swap trays (MCP-220-00090-0B)
 - Two (2) 25-cm 30AWG internal mini-SAS HD to mini-SAS HD cables (CBL-SAST-0550)
 - Two (2) 11-cm 30AWG internal RA reverse mini-SAS to mini-SAS HD cables (CBL-SAST-0706)
 - Two (2) 8-pin to 2x4-pin (35-cm and 22-cm) 18AWG, HF, RoHS/REACH, PBF power cables (CBL-PWEX-0460-05)
- Riser Cards:
 - Two (2) PCI-E 3.0 x16 riser cards (RSC-R2UFF-X2E16B-O-P)
 - Two (2) PCI-E 3.0 x16 riser cards (RSC-R4UFF-A2E16A-O-P)
 - Two (2) PCI-E 3.0 x16 riser cards (RSC-R4UFF-A4E16B-O-P)
- One (1) F418/F424 rail set (MCP-290-41803-0N)

Note: For your system to work properly, please follow the links below to download all necessary drivers/utilities and the user's manual for your server.

- Supermicro product manuals: <http://www.supermicro.com/support/manuals/>
- Product drivers and utilities: <ftp://ftp.supermicro.com>
- Product safety information:
http://www.supermicro.com/about/policies/safety_information.cfm
- If you have any questions, please contact our support team at:
support@supermicro.com

1-2 Serverboard Features

At the heart of the FatTwin F648G2-FC0+/FC0PT+ lies the X10DRFF-CG/CTG, a dual processor serverboard based on the Intel® C612 chipset and designed to provide maximum performance. Two of these serverboards can be mounted in the F442BG-R2K04BP chassis.

The sections below cover the main features of the X10DRFF-CG/CTG serverboard (see Figure 1-1 for a block diagram of the chipset).

Processors

The X10DRFF-CG/CTG supports single or dual Intel® Xeon® E5-2600v3 series processors (Socket R3 LGA 2011). Each processor supports four full-width Intel QuickPath Interconnect (QPI) links, with support of up to 25.6 GT/s per QPI link and with Data Transfer Rate of up to 9.6 GT/s per direction. Please refer to the serverboard description pages on our web site for a complete listing of supported processors (www.supermicro.com).

Memory

Each X10DRFF-CG/CTG serverboard node has sixteen (16) DIMM slots supporting up to 1024 GB of LDIMM registered ECC or up to 512 GB of RDIMM ECC at DDR4-2133/1866/1600 MHz speeds and up to 1 GB, 2 GB, 4 GB, 8 GB, 16 GB, 32 GB or 64 GB size at 1.2V voltages. See Chapter 5 for details.

Note: For the latest CPU/memory updates, please refer to our website at <http://www.supermicro.com/products/motherboard>.

Serial ATA

A Serial ATA controller is integrated into the C612 to provide up to ten (10) SATA 3.0 connections, including six (6) SATA 3.0 ports supported by Intel PCH (I-SATA 0-5) and four (4) SATA 3.0 with 4 connections supported by the PCH (S-SATA 0-3) .

These drives support RAID 0, 1, 5 and 10 capability. The SATA drives are hot-swappable units.

Note: The operating system you use must have RAID support to enable the hot-swap capability and RAID function of the SATA drives.

SAS

Each of the and serverboards contains an integrated LSI® LSI 3008 SAS3 controller that provides up to an eight port 12 Gb/s SAS3 (Serial Attached SCSI) supported subsystem (SAS 0-3, 4-7). These provide the system with a RAID 0, 1 and 10 capability. The SAS drives are hot-swappable units.

Note: The operating system you use must have RAID support to enable the hotswap capability and RAID function of the SAS drives.

PCI Expansion Slots

Each node in the the FatTwin F648G2-FC0+/FC0PT+ server has the following expansion slots:

- Two (2) PCI Express 3.0 x8 slots (CPU1 Slot2, CPU2 Slot3)
- One (1) PCI-Express 2.0 x4 slot (PCH Slot4)
- One (1) SMC-proprietary PCI Express x16 slot (SXB1)
- One (1) SMC-proprietary PCI Express x32 slot (SXB2)

Onboard Controllers/Ports

One Fast UART 16550 serial port is located on the serverboard. The I/O ports include one VGA (monitor) port, two rear mounted USB 3.0 ports, an IPMI dedicated LAN port and either two Gigabit or two 10GBased-T Ethernet ports.

Note: For IPMI Configuration Instructions, please refer to the Embedded IPMI Configuration User's Guide available @ <http://www.supermicro.com/support/manuals/>.

Graphics Controller

The X10DRFF-CG/CTG features an integrated Aspeed AST2400 BMC Controller for onboard graphics capability.

Aspeed AST2400 Controller

Note: The term "IPMI controller" and the term "BMC controller" can be used interchangeably in this section.

The Aspeed AST2400 Controller, a Baseboard Management Controller (BMC), supports 2D/VGA-compatible Graphic Cores with PCI interface, creating multi-media virtualization via Keyboard/Video/Mouse Redirection (KVMR). The WPCM450R Controller is ideal for remote system management.

The Aspeed AST2400 Controller interfaces with the host system via PCI connections to communicate with the graphics cores. It supports USB 3.0 and 2.0 for remote keyboard/mouse/virtual media emulation. It also provides LPC interface support to control Super IO functions. The Aspeed AST2400 is connected to the network via an external Ethernet PHY module or shared NCSI connections.

The Aspeed AST2400 communicates with onboard components via six SMBus interfaces, PECE (Platform Environment Control Interface) buses, and General Purpose I/O ports.

Other Features Supported by the Aspeed AST2400 Controller

The Aspeed AST2400 supports the following features:

- IPMI 2.0
- Serial over LAN
- KVM over LAN
- LAN Alerting-SNMP Trap
- Event Log
- X-Bus parallel interface for I/O expansion
- Multiple ADC inputs, Analog and Digital Video outputs
- SPI Flash Host BIOS and firmware bootstrap program supported
- Reduced Media Independent Interface (RMII)
- OS (Operating System) Independency
- Provides remote Hardware Health Monitoring via IPMI. Key features
- Provides Network Management Security via remote access/console redirection.
- Supports the following Management tools: IPMIView, CLI (Command Line Interface)
- RMCP+ protocol supported

Note: For more information on IPMI configuration, please refer to the IPMI User's Guide posted on our website at <http://www.supermicro.com/support/manuals/>.

Power Supply

Please connect the power cable from the SMC-Proprietary Adaptor (BPN-ADP-F418L) to the motherboard in order to provide power to the system.

Super I/O

The Super I/O provides functions that comply with ACPI (Advanced Configuration and Power Interface), which includes support of legacy and ACPI power management through an SMI or SCI function pin. It also features auto power management to reduce power consumption.

1-3 Server Chassis Features

The following is a general outline of the main features of the F442BG server chassis.

System Power

The F442BG chassis model includes four high-efficiency 1 + 1 Titanium Level 96%+ redundant 2000 Watt power supplies (PWS-2K04A-1R). In the unlikely event your power supply fails, replacement is simple and can be accomplished without tools.

Note: The power supplies are both redundant, hot-plug.

SAS/SATA Subsystem

The F442BG supports up to eight SATA3/SAS3 HDD drives. These drives are hot swappable units and are connected to two backplanes (that provides power and control) per node.

Note: For more information, visit our Web site at: <http://www.supermicro.com>.

I/O Ports

The F442BG is an proprietary form factor chassis designed to be used in a 4U rackmount configuration. The F442BG chassis provides two low-profile add-on card slots, a VGA port, two USB 3.0 ports, one IPMI Ethernet port and two Gigabit or 10GBased-T Ethernet ports per node.

Cooling System

The F442BG chassis supports external exhaust fans that provide cooling for the system. The F648G2-FC0+/FC0PT+ server uses eight (8) 8-cm external system fans powered from either the backplane or the serverboards. When one of the serverboard nodes is removed, another serverboard will continue to operate the fans.

Note: The fans in this system are redundant, but NOT hot-plug.

Air Shrouds

The F442BG chassis requires mylar air shrouds for each node to direct the airflow where cooling is needed. The air shroud will differ for different motherboards. If using a serverboard which is not the default in the chassis, refer to the optional parts in the Appendix of this manual, or the Supermicro Web site at www.supermicro.com to purchase the proper air shroud.

Mounting Rails

The F442BG includes a set of rails, and can be placed in a rack for secure storage and use. To setup your rack, follow the step-by-step instructions included in this manual.

1-4 Advanced Power Management

Intel® Intelligent Power Node Manager (NM)

The Intel® Intelligent Power Node Manager (IPNM) provides your system with real-time thermal control and power management for maximum energy efficiency. Although IPNM Specification Version 1.5 is supported by the BMC (Baseboard Management Controller), your system must also have IPNM-compatible Manageability Engine (ME) firmware installed to use this feature.

Manageability Engine (ME)

The Manageability Engine, which is an ARC controller embedded in the IOH (I/O Hub), provides Server Platform Services (SPS) to your system. The services provided by SPS are different from those provided by the ME on client platforms.

**Figure 1-1. Intel C612Chipset:
System Block Diagram**

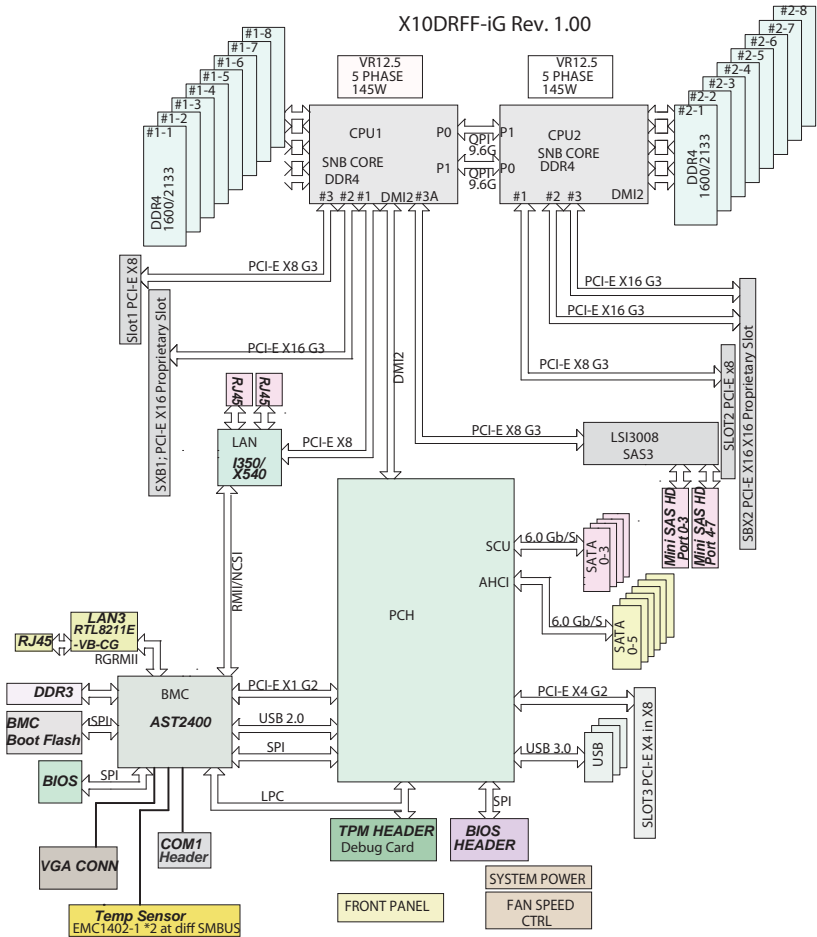

Note 1: This is a general block diagram and may not exactly represent the features on your motherboard. See the Motherboard Features pages for the actual specifications of each motherboard.

Note 2: Both CPUs need to be installed for full access to the PCI-E slots, DIMM slots, and onboard controllers. Refer to the block diagram above to determine which slots or devices may be affected.

1-5 Contacting Supermicro

Headquarters

Address: Super Micro Computer, Inc.
980 Rock Ave.
San Jose, CA 95131 U.S.A.

Tel: +1 (408) 503-8000

Fax: +1 (408) 503-8008

Email: marketing@supermicro.com (General Information)
support@supermicro.com (Technical Support)

Website: www.supermicro.com

Europe

Address: Super Micro Computer B.V.
Het Sterrenbeeld 28, 5215 ML
's-Hertogenbosch, The Netherlands

Tel: +31 (0) 73-6400390

Fax: +31 (0) 73-6416525

Email: sales@supermicro.nl (General Information)
support@supermicro.nl (Technical Support)
rma@supermicro.nl (Customer Support)

Website: www.supermicro.nl

Asia-Pacific

Address: Super Micro Computer, Inc.
3F, No. 150, Jian 1st Rd.
Zhonghe Dist., New Taipei City 235
Taiwan (R.O.C)

Tel: +886-(2) 8226-3990

Fax: +886-(2) 8226-3992

Email: support@supermicro.com.tw

Website: www.supermicro.com.tw

1-6 FatTwin: System Nodes

As a FatTwin configuration, the FatTwin F648G2-FC0+/FC0PT+ is a unique server system. With two system boards incorporated into a single chassis acting as two separate nodes, there are several points you should keep in mind.

Nodes

Each of the two serverboards act as a separate node in the system. As independant nodes, each may be powered off and on without affecting the other. In addition, each node is a hot-swappable unit that may be removed from the front of the chassis. The nodes are connected to the server backplane by means of an adapter card.

Note: A guide pin is located on the inner chassis wall. This guide pin also acts as a “stop” when a node is fully installed. If too much force is used when inserting a node this pin may break off. Take care to slowly slide a node in until you hear the “click” of the locking tab seating itself.

System Power

Four high-efficiency 96%+ Titanium Level 2000 Watt power supplies are used to provide the power for all serverboards. Each serverboard however, can be shut down independently of the other with the power button on its own control panel.

SAS/SATA Backplane/Drives

As a system, the FatTwin F648G2-FC0+/FC0PT+ supports the use of either eight (8) SAS3 or six (6) SATA3 drives per node. Each of the backplanes in the system logically connects the internal fixed SAS/SATA drives to each node's backplane/serverboard. See Chapter 6 for the logical hard drive and node configuration.

Notes

Chapter 2

Server Installation

2-1 Overview

This chapter provides a quick setup checklist to get your FatTwin F648G2-FC0+/FC0PT+ up and running. Following these steps in the order given should enable you to have the system operational within a minimum amount of time. This quick setup assumes that your system has come to you with the processors and memory preinstalled. If your system is not already fully integrated with a serverboard, processors, system memory etc., please turn to the chapter or section noted in each step for details on installing specific components.

2-2 Unpacking the System

You should inspect the box the FatTwin F648G2-FC0+/FC0PT+ was shipped in and note if it was damaged in any way. If the server itself shows damage you should file a damage claim with the carrier who delivered it.

Decide on a suitable location for the rack unit that will hold the FatTwin F648G2-FC0+/FC0PT+. It should be situated in a clean, dust-free area that is well ventilated. Avoid areas where heat, electrical noise and electromagnetic fields are generated. You will also need it placed near a grounded power outlet. Read the Rack and Server Precautions in the next section.

2-3 Preparing for Setup

The box the FatTwin F648G2-FC0+/FC0PT+ was shipped in should include two sets of rail assemblies, two rail mounting brackets and the mounting screws you will need to install the system into the rack. Follow the steps in the order given to complete the installation process in a minimum amount of time. Please read this section in its entirety before you begin the installation procedure outlined in the sections that follow.

2-4 Warnings and Precautions

Choosing a Setup Location

- Leave enough clearance in front of the rack to enable you to open the front door completely (~25 inches) and approximately 30 inches of clearance in the back of the rack to allow for sufficient airflow and ease in servicing.
- This product is for installation only in a Restricted Access Location (dedicated equipment rooms, service closets and the like).
- This product is not suitable for use with visual display work place devices according to §2 of the the German Ordinance for Work with Visual Display Units.

Rack Precautions

- Ensure that the leveling jacks on the bottom of the rack are fully extended to the floor with the full weight of the rack resting on them.
- In single rack installation, stabilizers should be attached to the rack. In multiple rack installations, the racks should be coupled together.
- Always make sure the rack is stable before extending a component from the rack.
- You should extend only one component at a time - extending two or more simultaneously may cause the rack to become unstable.

Server Precautions

- Review the electrical and general safety precautions in Chapter 4.
- Determine the placement of each component in the rack *before* you install the rails.
- Install the heaviest server components on the bottom of the rack first, and then work up.
- Use a regulating uninterruptible power supply (UPS) to protect the server from power surges, voltage spikes and to keep your system operating in case of a power failure.
- Allow any hot plug drives and power supply modules to cool before touching them.
- Always keep the rack's front door and all panels and components on the servers closed when not servicing to maintain proper cooling.

Rack Mounting Considerations



Warning! To prevent bodily injury when mounting or servicing this unit in a rack, you must take special precautions to ensure that the system remains stable. The following guidelines are provided to ensure your safety:

- This unit should be mounted at the bottom of the rack if it is the only unit in the rack.
- When mounting this unit in a partially filled rack, load the rack from the bottom to the top with the heaviest component at the bottom of the rack.
- If the rack is provided with stabilizing devices, install the stabilizers before mounting or servicing the unit in the rack.

Ambient Operating Temperature

If installed in a closed or multi-unit rack assembly, the ambient operating temperature of the rack environment may be greater than the ambient temperature of the room. Therefore, consideration should be given to installing the equipment in an environment compatible with the manufacturer's maximum rated ambient temperature (T_{mra}).

Reduced Airflow

Equipment should be mounted into a rack so that the amount of airflow required for safe operation is not compromised.

Mechanical Loading

Equipment should be mounted into a rack so that a hazardous condition does not arise due to uneven mechanical loading.

Circuit Overloading

Consideration should be given to the connection of the equipment to the power supply circuitry and the effect that any possible overloading of circuits might have on overcurrent protection and power supply wiring. Appropriate consideration of equipment nameplate ratings should be used when addressing this concern.

Reliable Ground

A reliable ground must be maintained at all times. To ensure this, the rack itself should be grounded. Particular attention should be given to power supply connections other than the direct connections to the branch circuit (i.e. the use of power strips, etc.).

2-5 Rack Mounting Instructions

This section provides information on installing the chassis into a rack unit with the rails provided. There are a variety of rack units on the market, which may mean that the assembly procedure will differ slightly from the instructions provided. You should also refer to the installation instructions that came with the rack unit you are using.

Note: This rail will fit a rack between 26.5" and 36.4" deep. The SCF418 is not designed for installation into a Telco post-style rack unit.



Warning: Do not pick up the server with the front handles. They are designed to pull the system from a rack only.



Stability Hazard: The rack stabilizing mechanism must be in place, or the rack must be bolted to the floor before you slide the unit out for servicing. Failure to stabilize the rack can cause the rack to tip over.



Warning: Slide rail mounted equipment is not to be used as a shelf or a work space.

Warning: When initially installing the server to a rack, test that the rail locking tabs engage to prevent the server from being overextended. Have a rack lift in place as a precaution in case the test fails.

Warning: In any instance of pulling the system from the rack, always use a rack lift and follow all associated safety precautions.

Identifying the Sections of the Rack Rails

The chassis package includes two rail assemblies in the rack mounting kit. Each assembly consists of two sections: A front section which secures to the front post of the rack and a rear section which adjusts in length and secures to the rear post of the rack. These assemblies are specifically designed for the left and right side of the chassis (see Figure 2-1).

Adjusting the Rails

Each rail assembly has an adjusting screw. loosening this screw allows you to adjust the length of the rail to fit a variety of rack sizes.

Locking Tabs

Each inner rail has a locking tab. This tab locks the chassis into place when installed and pushed fully into the rack. These tabs also lock the chassis in place when fully extended from the rack. This prevents the server from coming completely out of the rack when when the chassis is pulled out for servicing.

**Figure 2-1: Identifying the Outer Rail and Inner Rails
(Left Rail Assembly Shown)**

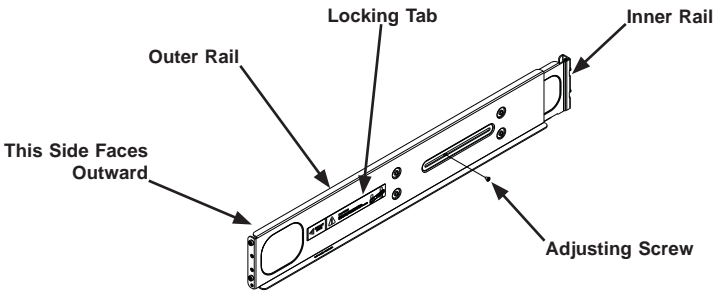

Installing the Rails on a Rack

Installing the Rails

1. Adjust the length of both rails as described on the previous page.
2. Align the front section of the outer rail with the slots on the front post of the rack. Secure the front of the outer rail to the rack with two screws.
3. Pull out the rear section of the outer rail, adjusting the length until it fits within the posts of the rack.
4. Align the rear section of the rail with the slots on the rear post of the rack. Secure the rear of the outer rail to the rear of the rack with two screws.
5. Repeat steps 1-4 for the remaining rail.

Figure 2-2: Attaching the Rails to a Rack

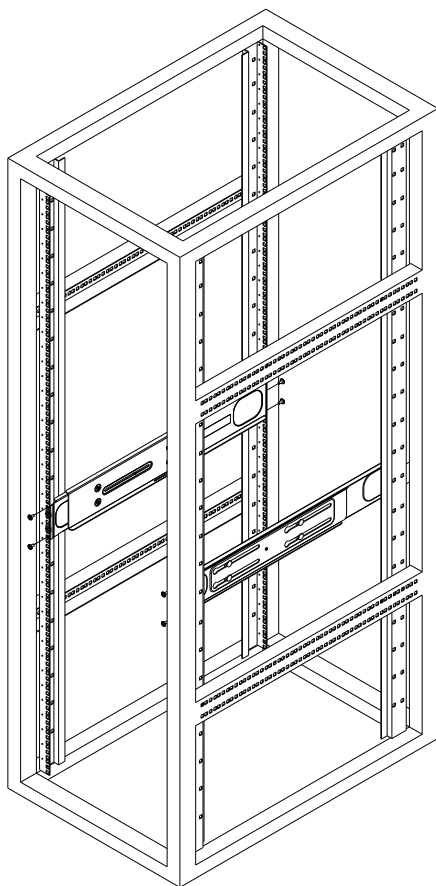

Chassis Installation

Installing the Chassis into a Rack

1. Confirm that the rails are correctly installed on the rack.
2. Align the bottom of the chassis with the bottom of the rails.
3. Insert the chassis into the rails, keeping the pressure even on both sides, pushing the chassis into the rack until it clicks into the locked position.
4. Secure the chassis handles to the front of the rack.

Figure 2-3: Installing into a Rack

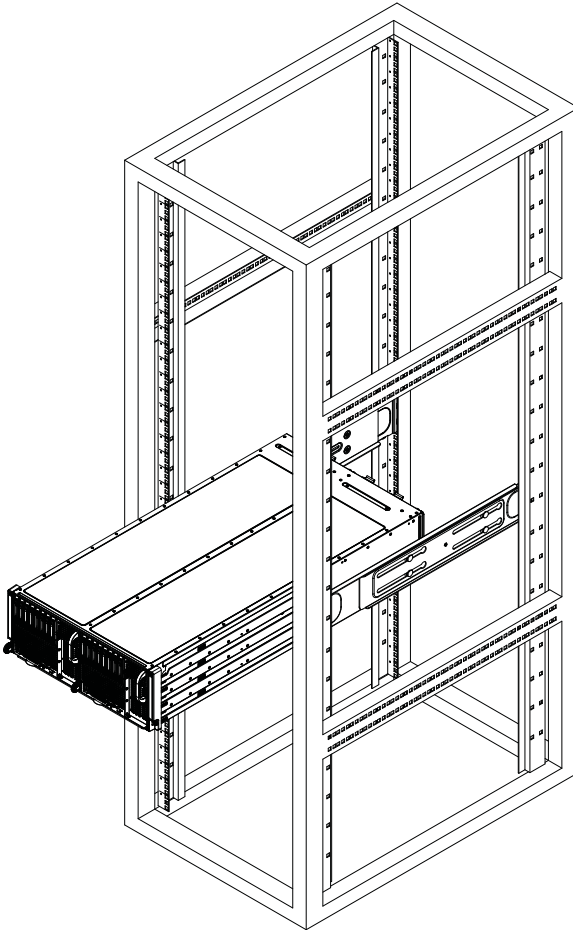

Note: The figure above is for illustration purposes only. Always install servers to the bottom of the rack first.

2-6 Checking the Serverboard Setup

After you install the SuperServer F648G2-FC0+/FC0PT+ in the rack, you will need to open the unit to make sure the serverboard is properly installed and all the connections have been made.

Accessing the inside of the System

Before operating the server for the first time, it is important to remove the protective film covering the top of the chassis, in order to allow for proper ventilation and cooling.

Warning: Except for short periods of time, do NOT operate the server without the cover in place. The chassis cover must be in place to allow proper airflow and prevent overheating.

Checking the Components and Setup

1. You may have one or two processors already installed into the serverboard. Each processor needs its own heat sink. See Chapter 5 for instructions on processor and heat sink installation.
2. Your SuperServer F648G2-FC0+/FC0PT+ server system may have come with system memory already installed. Make sure all DIMMs are fully seated in their slots. For details on adding system memory, refer to Chapter 5.
3. If desired, you can install add-on cards to the system. See Chapter 5 for details on installing PCI add-on cards.
4. Make sure all power and data cables are properly connected and not blocking the chassis airflow. Also make sure that no cables are positioned in front of the fans. See Chapter 5 for details on cable connections.

2-7 Checking the Drive Bay Setup

Next, you should check to make sure the peripheral drives and the SATA drives have been properly installed and all connections have been made.

Checking the Drives

1. All drives are accessible from the front of the server. A hard drive can be installed and removed from the front of the chassis without removing the top chassis cover.
2. Depending upon your system's configuration, your system may have one or more drives already installed. If you need to install hard drives, please refer to Chapter 6.

Checking the Airflow

1. Make sure there are no objects to obstruct airflow in and out of the server. In addition, if you are using a front bezel, make sure the bezel's filter is replaced periodically.
2. Do not operate the server without drives or drive trays in the drive bays. Use only recommended server parts.
3. Make sure that no wires or foreign objects obstruct air flow through the chassis. Pull all excess cabling out of the airflow path or use shorter cables. The control panel LEDs inform you of the system status. See "Chapter 3 System Interface" for details on the LEDs and the control panel buttons.

Providing Power

1. Plug the power cord(s) from the power supply unit(s) into a high-quality power strip that offers protection from electrical noise and power surges. It is recommended that you use an uninterruptible power supply (UPS).
2. Depress the power on button on the front of the chassis.

Notes

Chapter 3

System Interface

3-1 Overview

There are several LEDs on the control panel to keep you constantly informed of the overall status of the system. F442BG models include two control panels which control each of the systems.

This chapter explains the meanings of all LED indicators and the appropriate response you may need to take.

3-3 F442BG Front I/O Control Panel

The F442BG chassis include a power button with a built-in LED and features both a LAN LED and a UID LED on each node's front control panel.

Figure 3-2: F442BG Node Control Panel

(Your chassis and drives may differ from those shown in this illustration)

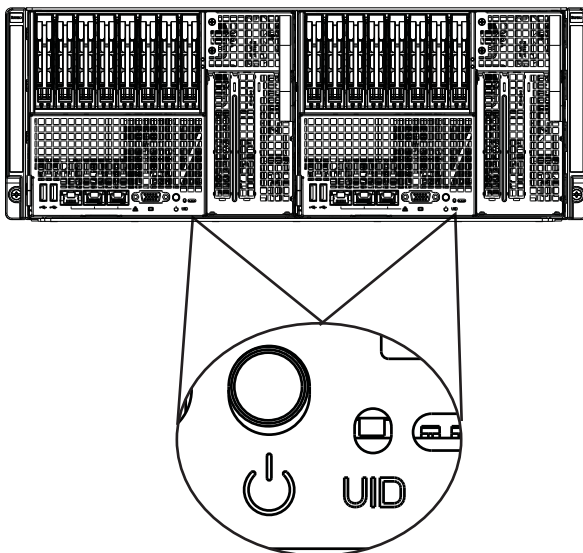



Power

The main power button on each of the two control panels is used to apply or remove power from the power supply to each of the two systems in the chassis. Turning off system power with this button removes the main power, but keeps standby power supplied to the system. Therefore, you must unplug system before servicing. The power button has a built-in LED which will turn green when the power is on.



UID

When used with a UID compatible serverboard, the UID button is used to turn on or off the blue light function of the LED. This is built into the front side of the UID button and at the rear end of each serverboard node, for those motherboards which support it. Once the blue light is activated, the unit can be easily located in very large racks and server banks.

3-4 Drive Carrier LEDs

The chassis includes externally accessible SAS/SATA drives. Each drive carrier displays two status LEDs on the front of the carrier.

	LED Color	State	Status
Activity LED	Green	Solid On	SAS drive installed
	Green	Blinking	I/O activity
Status LED	Red	Solid On	Failed drive for SAS/SATA with RSTe support
	Red	Blinking at 1 Hz	Rebuild drive for SAS/SATA with RSTe support
	Red	Blinking with two blinks and one stop at 1 Hz	Hot spare for SAS/SATA with RSTe support
	Red	On for five seconds, then off	Power on for SAS/SATA with RSTe support
	Red	Blinking at 4 Hz	Identify drive for SAS/SATA with RSTe support

Chapter 4

Standardized Warning Statements for AC Systems

4-1 About Standardized Warning Statements

The following statements are industry standard warnings, provided to warn the user of situations which have the potential for bodily injury. Should you have questions or experience difficulty, contact Supermicro's Technical Support department for assistance. Only certified technicians should attempt to install or configure components.

Read this appendix in its entirety before installing or configuring components in the Supermicro chassis.

These warnings may also be found on our web site at http://www.supermicro.com/about/policies/safety_information.cfm.

Warning Definition



Warning!

This warning symbol means danger. You are in a situation that could cause bodily injury. Before you work on any equipment, be aware of the hazards involved with electrical circuitry and be familiar with standard practices for preventing accidents.

警告の定義

この警告サインは危険を意味します。

人身事故につながる可能性がありますので、いずれの機器でも動作させる前に、電気回路に含まれる危険性に注意して、標準的な事故防止策に精通して下さい。

此警告符号代表危險。

您正處於可能受到嚴重傷害的工作環境中。在您使用設備開始工作之前，必須充分意識到觸電的危險，並熟练掌握防止事故發生的標準工作程序。請根據每項警告結尾的聲明號碼找到此設備的安全性警告說明的翻譯文本。

此警告符號代表危險。

您正處於可能身體可能會受損傷的工作環境中。在您使用任何設備之前，請注意觸電的危險，並且要熟悉預防事故發生的標準工作程序。請依照每一注意事項後的號碼找到相關的翻譯說明內容。

Warnung

WICHTIGE SICHERHEITSHINWEISE

Dieses Warnsymbol bedeutet Gefahr. Sie befinden sich in einer Situation, die zu Verletzungen führen kann. Machen Sie sich vor der Arbeit mit Geräten mit den Gefahren elektrischer Schaltungen und den üblichen Verfahren zur Vorbeugung vor Unfällen vertraut. Suchen Sie mit der am Ende jeder Warnung angegebenen Anweisungsnummer nach der jeweiligen Übersetzung in den übersetzten Sicherheitshinweisen, die zusammen mit diesem Gerät ausgeliefert wurden.

BEWAHREN SIE DIESE HINWEISE GUT AUF.

INSTRUCCIONES IMPORTANTES DE SEGURIDAD

Este símbolo de aviso indica peligro. Existe riesgo para su integridad física. Antes de manipular cualquier equipo, considere los riesgos de la corriente eléctrica y familiarícese con los procedimientos estándar de prevención de accidentes. Al final de cada advertencia encontrará el número que le ayudará a encontrar el texto traducido en el apartado de traducciones que acompaña a este dispositivo.

GUARDE ESTAS INSTRUCCIONES.

IMPORTANTES INFORMATIONS DE SÉCURITÉ

Ce symbole d'avertissement indique un danger. Vous vous trouvez dans une situation pouvant entraîner des blessures ou des dommages corporels. Avant de travailler sur un équipement, soyez conscient des dangers liés aux circuits électriques et familiarisez-vous avec les procédures couramment utilisées pour éviter les accidents. Pour prendre connaissance des traductions des avertissements figurant dans les consignes de sécurité traduites qui accompagnent cet appareil, référez-vous au numéro de l'instruction situé à la fin de chaque avertissement.

CONSERVEZ CES INFORMATIONS.

תקנון הצהרות אזהרה

הצהרות הבאות הן אזהרות על פי תקני התעשייה, על מנת להזהיר את המשתמש מפני חבלה פיזית אפשרית. במידה ויש שאלות או היתקלות בבעיה כלשהי, יש ליצור קשר עם מחלקת תמיכה טכנית של סופרמיקרו. טכנאים מוסמכים בלבד רשאים להתקין או להגדיר את הרכיבים.

יש לקרוא את הנספח במלואו לפני התקנת או הגדרת הרכיבים במארזי סופרמיקרו.

تحذير! هذا الرمز يعني خطر انك في حالة يمكن أن تتسبب في اصابة جسدية .
قبل أن تعمل على أي معدات، كن على علم بالمخاطر الناجمة عن الدوائر
الكهربائية
وكن على دراية بالممارسات الوقائية لمنع وقوع أي حوادث
استخدم رقم البيان المنصوص في نهاية كل تحذير للعثور ترجمتها

안전을 위한 주의사항

경고!

이 경고 기호는 위험이 있음을 알려 줍니다. 작업자의 신체에 부상을 야기 할 수 있는 상태에 있게 됩니다. 모든 장비에 대한 작업을 수행하기 전에 전기회로와 관련된 위험요소들을 확인하시고 사전에 사고를 방지할 수 있도록 표준 작업절차를 준수해 주시기 바랍니다.

해당 번역문을 찾기 위해 각 경고의 마지막 부분에 제공된 경고문 번호를 참조하십시오

BELANGRIJKE VEILIGHEIDSINSTRUCTIES

Dit waarschuwings symbool betekent gevaar. U verkeert in een situatie die lichamelijk letsel kan veroorzaken. Voordat u aan enige apparatuur gaat werken, dient u zich bewust te zijn van de bij een elektrische installatie betrokken risico's en dient u op de hoogte te zijn van de standaard procedures om ongelukken te voorkomen. Gebruik de nummers aan het eind van elke waarschuwing om deze te herleiden naar de desbetreffende locatie.

BEWAAR DEZE INSTRUCTIES

Installation Instructions



Warning!

Read the installation instructions before connecting the system to the power source.

設置手順書

システムを電源に接続する前に、設置手順書をお読み下さい。

警告

将此系统连接电源前，请先阅读安装说明。

警告

將系統與電源連接前，請先閱讀安裝說明。

Warnung

Vor dem Anschließen des Systems an die Stromquelle die Installationsanweisungen lesen.

¡Advertencia!

Lea las instrucciones de instalación antes de conectar el sistema a la red de alimentación.

Attention

Avant de brancher le système sur la source d'alimentation, consulter les directives d'installation.

יש לקרוא את הוראות התקנה לפני חיבור המערכת למקור מתח.

اقر إرشادات التركيب قبل توصيل النظام إلى مصدر للطاقة

시스템을 전원에 연결하기 전에 설치 안내를 읽어주십시오.

Waarschuwing

Raadpleeg de installatie-instructies voordat u het systeem op de voedingsbron aansluit.

Circuit Breaker



Warning!

This product relies on the building's installation for short-circuit (overcurrent) protection. Ensure that the protective device is rated not greater than: 250 V, 20 A.

サーキット・ブレーカー

この製品は、短絡(過電流)保護装置がある建物での設置を前提としています。
保護装置の定格が250 V、20 Aを超えないことを確認下さい。

警告

此产品的短路(过载电流)保护由建筑物的供电系统提供,确保短路保护设备的额定电流不大于250V,20A。

警告

此產品的短路(過載電流)保護由建築物的供電系統提供,確保短路保護設備的額定電流不大於250V,20A。

Warnung

Dieses Produkt ist darauf angewiesen, dass im Gebäude ein Kurzschluss- bzw. Überstromschutz installiert ist. Stellen Sie sicher, dass der Nennwert der Schutzvorrichtung nicht mehr als: 250 V, 20 A beträgt.

¡Advertencia!

Este equipo utiliza el sistema de protección contra cortocircuitos (o sobrecorrientes) del edificio. Asegúrese de que el dispositivo de protección no sea superior a: 250 V, 20 A.

Attention

Pour ce qui est de la protection contre les courts-circuits (surtension), ce produit dépend de l'installation électrique du local. Vérifiez que le courant nominal du dispositif de protection n'est pas supérieur à :250 V, 20 A.

מוצר זה מסתמך על הגנה המותקנת במבנים למניעת קצר חשמלי. יש לוודא כי
המכשיר המגן מפני הקצר החשמלי הוא לא יותר מ-250 V, 20 A

هذا المنتج يعتمد على معدات الحماية من الدوائر القصيرة التي تم تثبيتها في
المبنى

تأكد من أن تقييم الجهاز الوقائي ليس أكثر من: 20A, 250V

경고!

이 제품은 전원의 단락(과전류)방지에 대해서 전적으로 건물의 관련 설비에 의존합니다. 보호장치의 정격이 반드시 250V(볼트), 20A(암페어)를 초과하지 않도록 해야 합니다.

Waarschuwing

Dit product is afhankelijk van de kortsluitbeveiliging (overspanning) van uw elektrische installatie. Controleer of het beveiligde apparaat niet groter gedimensioneerd is dan 220V, 20A.

Power Disconnection Warning



Warning!

The system must be disconnected from all sources of power and the power cord removed from the power supply module(s) before accessing the chassis interior to install or remove system components.

電源切斷の警告

システムコンポーネントの取り付けまたは取り外しのために、シャーシ内部にアクセスするには、

システムの電源はすべてのソースから切斷され、電源コードは電源モジュールから取り外す必要があります。

警告

在你打开机箱并安装或移除内部器件前,必须将系统完全断电,并移除电源线。

警告

在您打開機殼安裝或移除內部元件前,必須將系統完全斷電,並移除電源線。

Warnung

Das System muss von allen Quellen der Energie und vom Netzanschlusskabel getrennt sein, das von den Spg.Versorgungsteilmodulen entfernt wird, bevor es auf den Chassisinnenraum zurückgreift, um Systemsbestandteile anzubringen oder zu entfernen.

¡Advertencia!

El sistema debe ser disconnected de todas las fuentes de energía y del cable eléctrico quitado de los módulos de fuente de alimentación antes de tener acceso el interior del chasis para instalar o para quitar componentes de sistema.

Attention

Le système doit être débranché de toutes les sources de puissance ainsi que de son cordon d'alimentation secteur avant d'accéder à l'intérieur du chasis pour installer ou enlever des composants de système.

אזהרה מפני ניתוק חשמלי

אזהרה!

יש לנתק את המערכת מכל מקורות החשמל ויש להסיר את כבל החשמלי מהספק לפני גישה לחלק הפנימי של המארז לצורך התקנת או הסרת רכיבים.

يجب فصل النظام من جميع مصادر الطاقة وإزالة سلك الكهرباء من وحدة امداد الطاقة قبل الوصول إلى المناطق الداخلية للهيكल لتثبيت أو إزالة مكونات الجهاز

경고!

시스템에 부품들을 장착하거나 제거하기 위해서는 새시 내부에 접근하기 전에 반드시 전원 공급장치로부터 연결되어있는 모든 전원과 전기코드를 분리해주어야 합니다.

Waarschuwing

Voordat u toegang neemt tot het binnenwerk van de behuizing voor het installeren of verwijderen van systeem onderdelen, dient u alle spanningsbronnen en alle stroomkabels aangesloten op de voeding(en) van de behuizing te verwijderen

Equipment Installation



Warning!

Only trained and qualified personnel should be allowed to install, replace, or service this equipment.

機器の設置

トレーニングを受け認定された人だけがこの装置の設置、交換、またはサービスを許可されています。

警告

只有经过培训且具有资格的人员才能进行此设备的安装、更换和维修。

警告

只有經過受訓且具資格人員才可安裝、更換與維修此設備。

Warnung

Das Installieren, Ersetzen oder Bedienen dieser Ausrüstung sollte nur geschultem, qualifiziertem Personal gestattet werden.

¡Advertencia!

Solamente el personal calificado debe instalar, reemplazar o utilizar este equipo.

Attention

Il est vivement recommandé de confier l'installation, le remplacement et la maintenance de ces équipements à des personnels qualifiés et expérimentés.

אזהרה!

צוות מוסמך בלבד רשאי להתקין, להחליף את הציוד או לתת שירות עבור הציוד.

يجب أن يسمح فقط للموظفين المؤهلين والمدربين لتثبيت واستبدال أو خدمة هذا الجهاز

경고!

훈련을 받고 공인된 기술자만이 이 장비의 설치, 교체 또는 서비스를 수행할 수 있습니다.

Waarschuwing

Deze apparatuur mag alleen worden geïnstalleerd, vervangen of hersteld door geschoold en gekwalificeerd personeel.

Restricted Area



Warning!

This unit is intended for installation in restricted access areas. A restricted access area can be accessed only through the use of a special tool, lock and key, or other means of security. (This warning does not apply to workstations).

アクセス制限区域

このユニットは、アクセス制限区域に設置されることを想定しています。

アクセス制限区域は、特別なツール、鍵と錠前、その他のセキュリティの手段を用いてのみ出入りが可能です。

警告

此部件应安装在限制进出的场所，限制进出的场所指只能通过使用特殊工具、锁和钥匙或其它安全手段进出的场所。

警告

此裝置僅限安裝於進出管制區域，進出管制區域係指僅能以特殊工具、鎖頭及鑰匙或其他安全方式才能進入的區域。

Warnung

Diese Einheit ist zur Installation in Bereichen mit beschränktem Zutritt vorgesehen. Der Zutritt zu derartigen Bereichen ist nur mit einem Spezialwerkzeug, Schloss und Schlüssel oder einer sonstigen Sicherheitsvorkehrung möglich.

¡Advertencia!

Esta unidad ha sido diseñada para instalación en áreas de acceso restringido. Sólo puede obtenerse acceso a una de estas áreas mediante la utilización de una herramienta especial, cerradura con llave u otro medio de seguridad.

Attention

Cet appareil doit être installée dans des zones d'accès réservés. L'accès à une zone d'accès réservé n'est possible qu'en utilisant un outil spécial, un mécanisme de verrouillage et une clé, ou tout autre moyen de sécurité.

אזור עם גישה מוגבלת

!אזהרה!

יש להתקין את היחידה באזורים שיש בהם הגבלת גישה. הגישה ניתנת בעזרת כלי אבטחה בלבד (מפתח, מנעול וכד').

تم تخصيص هذه الوحدة لتركيبها في مناطق محظورة .
يمكن الوصول إلى منطقة محظورة فقط من خلال استخدام أداة خاصة،
قفل ومفتاح أو أي وسيلة أخرى للأمان

경고!

이 장치는 접근이 제한된 구역에 설치하도록 되어있습니다. 특수도구, 잠금 장치 및 키, 또는 기타 보안 수단을 통해서만 접근 제한 구역에 들어갈 수 있습니다.

Waarschuwing

Dit apparaat is bedoeld voor installatie in gebieden met een beperkte toegang. Toegang tot dergelijke gebieden kunnen alleen verkregen worden door gebruik te maken van speciaal gereedschap, slot en sleutel of andere veiligheidsmaatregelen.

Battery Handling



Warning!

There is the danger of explosion if the battery is replaced incorrectly. Replace the battery only with the same or equivalent type recommended by the manufacturer. Dispose of used batteries according to the manufacturer's instructions

電池の取り扱い

電池交換が正しく行われなかった場合、破裂の危険性があります。交換する電池はメーカーが推奨する型、または同等のものを使用下さい。使用済電池は製造元の指示に従って処分して下さい。

警告

电池更换不当会有爆炸危险。请只使用同类电池或制造商推荐的功能相当的电池更换原有电池。请按制造商的说明处理废旧电池。

警告

電池更換不當會有爆炸危險。請使用製造商建議之相同或功能相當的電池更換原有電池。請按照製造商的說明指示處理廢棄舊電池。

Warnung

Bei Einsetzen einer falschen Batterie besteht Explosionsgefahr. Ersetzen Sie die Batterie nur durch den gleichen oder vom Hersteller empfohlenen Batterietyp. Entsorgen Sie die benutzten Batterien nach den Anweisungen des Herstellers.

Attention

Danger d'explosion si la pile n'est pas remplacée correctement. Ne la remplacer que par une pile de type semblable ou équivalent, recommandée par le fabricant. Jeter les piles usagées conformément aux instructions du fabricant.

¡Advertencia!

Existe peligro de explosión si la batería se reemplaza de manera incorrecta. Reemplazar la batería exclusivamente con el mismo tipo o el equivalente recomendado por el fabricante. Desechar las baterías gastadas según las instrucciones del fabricante.

אזהרה!

קיימת סכנת פיצוץ של הסוללה במידה והוחלפה בדרך לא תקינה. יש להחליף את הסוללה בסוג התואם מחברת יצרן מומלצת.

סילוק הסוללות המשומשות יש לבצע לפי הוראות היצרן.

هناك خطر من انفجار في حالة استبدال البطارية بطريقة غير صحيحة فعليك استبدال البطارية فقط بنفس النوع أو ما يعادلها كما أوصت به الشركة المصنعة تخلص من البطاريات المستعملة وفقا لتعليمات الشركة الصانعة

경고!

배터리가 올바르게 교체되지 않으면 폭발의 위험이 있습니다. 기존 배터리와 동일하거나 제조사에서 권장하는 동등한 종류의 배터리로만 교체해야 합니다. 제조사의 안내에 따라 사용된 배터리를 처리하여 주십시오.

Waarschuwing

Er is ontploffingsgevaar indien de batterij verkeerd vervangen wordt. Vervang de batterij slechts met hetzelfde of een equivalent type die door de fabrikant aanbevolen wordt. Gebruikte batterijen dienen overeenkomstig fabrieksvoorschriften afgevoerd te worden.

Redundant Power Supplies



Warning!

This unit might have more than one power supply connection. All connections must be removed to de-energize the unit.

冗長電源装置

このユニットは複数の電源装置が接続されている場合があります。
ユニットの電源を切るためには、すべての接続を取り外さなければなりません。

警告

此部件连接的电源可能不止一个，必须将所有电源断开才能停止给该部件供电。

警告

此装置连接的电源可能不只一个，必须切断所有电源才能停止对该装置的供电。

Warnung

Dieses Gerät kann mehr als eine Stromzufuhr haben. Um sicherzustellen, dass der Einheit kein Strom zugeführt wird, müssen alle Verbindungen entfernt werden.

¡Advertencia!

Puede que esta unidad tenga más de una conexión para fuentes de alimentación. Para cortar por completo el suministro de energía, deben desconectarse todas las conexiones.

Attention

Cette unité peut avoir plus d'une connexion d'alimentation. Pour supprimer toute tension et tout courant électrique de l'unité, toutes les connexions d'alimentation doivent être débranchées.

אם קיים יותר מספק אחד

אזהרה!

ליחידה יש יותר מחיבור אחד של ספק. יש להסיר את כל החיבורים על מנת לרוקן את היחידה.

قد يكون لهذا الجهاز عدة اتصالات بوحدات امداد الطاقة.
يجب إزالة كافة الاتصالات لعزل الوحدة عن الكهرباء

경고!

이 장치에는 한 개 이상의 전원 공급 단자가 연결되어 있을 수 있습니다. 이 장치에 전원을 차단하기 위해서는 모든 연결 단자를 제거해야만 합니다.

Waarschuwing

Deze eenheid kan meer dan één stroomtoevoeraansluiting bevatten. Alle aansluitingen dienen verwijderd te worden om het apparaat stroomloos te maken.

Backplane Voltage



Warning!

Hazardous voltage or energy is present on the backplane when the system is operating. Use caution when servicing.

バックプレーンの電圧

システムの稼働中は危険な電圧または電力が、バックプレーン上にかかっています。
修理するには注意ください。

警告

当系统正在进行时，背板上有很危险的电压或能量，进行维修时务必小心。

警告

當系統正在進行時，背板上有很危險的電壓或能量，進行維修時務必小心。

Warnung

Wenn das System in Betrieb ist, treten auf der Rückwandplatine gefährliche Spannungen oder Energien auf. Vorsicht bei der Wartung.

¡Advertencia!

Cuando el sistema está en funcionamiento, el voltaje del plano trasero es peligroso. Tenga cuidado cuando lo revise.

Attention

Lorsque le système est en fonctionnement, des tensions électriques circulent sur le fond de panier. Prendre des précautions lors de la maintenance.

מתח בפנל האחורי

אזהרה!
קיימת סכנת מתח בפנל האחורי בזמן תפעול המערכת. יש להיזהר במהלך העבודה.

هناك خطر من التيار الكهربائي أو الطاقة الموجودة على اللوحة عندما يكون النظام يعمل كن حذرا عند خدمة هذا الجهاز

경고!

시스템이 동작 중일 때 후면판 (Backplane)에는 위험한 전압이나 에너지가 발생합니다. 서비스 작업 시 주의하십시오.

Waarschuwing

Een gevaarlijke spanning of energie is aanwezig op de backplane wanneer het systeem in gebruik is. Voorzichtigheid is geboden tijdens het onderhoud.

Comply with Local and National Electrical Codes



Warning!

Installation of the equipment must comply with local and national electrical codes.

地方および国の電気規格に準拠

機器の取り付けはその地方および国の電気規格に準拠する必要があります。

警告

设备安装必须符合本地与本国电气法规。

警告

設備安裝必須符合本地與本國電氣法規。

Warnung

Die Installation der Geräte muss den Sicherheitsstandards entsprechen.

¡Advertencia!

La instalacion del equipo debe cumplir con las normas de electricidad locales y nacionales. Attention

L'équipement doit être installé conformément aux normes électriques nationales et locales.

תיאום חוקי החשמל הארצי

אזהרה!

התקנת הציוד חייבת להיות תואמת לחוקי החשמל המקומיים והארציים.

تركيب المعدات الكهربائية يجب أن يمتثل للقوانين المحلية والوطنية المتعلقة بالكهرباء

경고!

현 지역 및 국가의 전기 규정에 따라 장비를 설치해야 합니다.

Waarschuwing

Bij installatie van de apparatuur moet worden voldaan aan de lokale en nationale elektriciteitsvoorschriften.

Product Disposal



Warning!

Ultimate disposal of this product should be handled according to all national laws and regulations.

製品の廃棄

この製品を廃棄処分する場合、国の関係する全ての法律・条例に従い処理する必要があります。

警告

本产品的废弃处理应根据所有国家的法律和规章进行。

警告

本產品的廢棄處理應根據所有國家的法律和規章進行。

Warnung

Die Entsorgung dieses Produkts sollte gemäß allen Bestimmungen und Gesetzen des Landes erfolgen.

¡Advertencia!

Al deshacerse por completo de este producto debe seguir todas las leyes y reglamentos nacionales.

Attention

La mise au rebut ou le recyclage de ce produit sont généralement soumis à des lois et/ou directives de respect de l'environnement. Renseignez-vous auprès de l'organisme compétent.

סילוק המוצר

אזהרה!

סילוק סופי של מוצר זה חייב להיות בהתאם להנחיות וחוקי המדינה.

عند التخلص النهائي من هذا المنتج ينبغي التعامل معه وفقا لجميع القوانين واللوائح الوطنية

경고!

이 제품은 해당 국가의 관련 법규 및 규정에 따라 폐기되어야 합니다.

Waarschuwing

De uiteindelijke verwijdering van dit product dient te geschieden in overeenstemming met alle nationale wetten en reglementen.

Hot Swap Fan Warning



Warning!

The fans might still be turning when you remove the fan assembly from the chassis. Keep fingers, screwdrivers, and other objects away from the openings in the fan assembly's housing.

ファン・ホットスワップの警告

シャーシから冷却ファン装置を取り外した際、ファンがまだ回転している可能性があります。ファンの開口部に、指、ドライバー、およびその他のものを近づけないで下さい。

警告

当您从机架移除风扇装置，风扇可能仍在转动。小心不要将手指、螺丝起子和其他物品太靠近风扇

警告

當您從機架移除風扇裝置，風扇可能仍在轉動。小心不要將手指、螺絲起子和其他物品太靠近風扇。

Warnung

Die Lüfter drehen sich u. U. noch, wenn die Lüfterbaugruppe aus dem Chassis genommen wird. Halten Sie Finger, Schraubendreher und andere Gegenstände von den Öffnungen des Lüftergehäuses entfernt.

¡Advertencia!

Los ventiladores podran dar vuelta cuando usted quite el montaje del ventilador del chasis. Mantenga los dedos, los destornilladores y todos los objetos lejos de las aberturas del ventilador

Attention

Il est possible que les ventilateurs soient toujours en rotation lorsque vous retirerez le bloc ventilateur du châssis. Prenez garde à ce que doigts, tournevis et autres objets soient éloignés du logement du bloc ventilateur.

אזהרה!

כאשר מסירים את חלקי המאוורר מהמארז, יתכן והמאווררים עדיין עובדים. יש להרחיק למרחק בטוח את האצבעות וכלי עבודה שונים מהפתחים בתוך המאוורר

من الممكن أن المراوح لا تزال تدور عند إزالة كتلة المروحة من الهيكل يجب إبقاء الأصابع ومفكات البراغي وغيرها من الأشياء بعيدا عن الفتحات في كتلة المروحة.

경고!

새시로부터 팬 조립품을 제거할 때 팬은 여전히 회전하고 있을 수 있습니다. 팬 조립품 외관의 열려있는 부분들로부터 손가락 및 스크류드라이버, 다른 물체들이 가까이 하지 않도록 배치해 주십시오.

Waarschuwing

Het is mogelijk dat de ventilator nog draait tijdens het verwijderen van het ventilatorsamenstel uit het chassis. Houd uw vingers, schroevendraaiers en eventuele andere voorwerpen uit de buurt van de openingen in de ventilatorbehuizing.

Power Cable and AC Adapter



Warning!

When installing the product, use the provided or designated connection cables, power cables and AC adaptors. Using any other cables and adaptors could cause a malfunction or a fire. Electrical Appliance and Material Safety Law prohibits the use of UL or CSA -certified cables (that have UL/CSA shown on the code) for any other electrical devices than products designated by Supermicro only.

電源コードとACアダプター

製品を設置する場合、提供または指定された接続ケーブル、電源コードとACアダプターを使用下さい。他のケーブルやアダプタを使用すると故障や火災の原因になることがあります。電気用品安全法は、ULまたはCSA認定のケーブル(UL/CSEマークがコードに表記)を Supermicroが指定する製品以外に使用することを禁止しています。

警告

安裝此產品時，請使用本身提供的或指定的連接線，電源線和電源適配器。使用其它線材或適配器可能會引起故障或火災。除了 Supermicro 所指定的產品，電氣用品和材料安全法律規定禁止使用未經 UL 或 CSA 認證的線材。（線材上會顯示 UL/CSA 符號）。

警告

安裝此產品時，請使用本身提供的或指定的連接線，電源線和電源適配器。使用其它線材或適配器可能會引起故障或火災。除了 Supermicro 所指定的產品，電氣用品和材料安全法律規定禁止使用未經 UL 或 CSA 認證的線材。（線材上會顯示 UL/CSA 符號）。

Warnung

Bei der Installation des Produkts, die zur Verfügung gestellten oder benannt Anschlusskabel, Stromkabel und Netzteile. Verwendung anderer Kabel und Adapter kann zu einer Fehlfunktion oder ein Brand entstehen. Elektrische Geräte und Material Safety Law verbietet die Verwendung von UL-oder CSA-zertifizierte Kabel, UL oder CSA auf der Code für alle anderen elektrischen Geräte als Produkte von Supermicro nur bezeichnet gezeigt haben.

¡Advertencia!

Al instalar el producto, utilice los cables de conexión previstos o designados, los cables y adaptadores de CA. La utilización de otros cables y adaptadores podría ocasionar un mal funcionamiento o un incendio. Aparatos Eléctricos y la Ley de Seguridad del Material prohíbe el uso de UL o CSA cables certificados que tienen UL o CSA se muestra en el código de otros dispositivos eléctricos que los productos designados por Supermicro solamente.

Attention

Lors de l'installation du produit, utilisez les bables de connection fournis ou désigné. L'utilisation d'autres cables et adaptateurs peut provoquer un dysfonctionnement ou un incendie. Appareils électroménagers et de loi sur la sécurité Matériel interdit l'utilisation de UL ou CSA câbles certifiés qui ont UL ou CSA indiqué sur le code pour tous les autres appareils électriques que les produits désignés par Supermicro seulement.

AC שמשליים ומתאמי

אזהרה!

כאשר מתקינים את המוצר, יש להשתמש בכבלים, ספקים ומתאמים AC אשר נועדו וסופקו לשם כך. שימוש בכל כבל או מתאם אחר יכול לגרום לתקלה או קצר חשמלי. על פי חוקי שימוש במכשירי חשמל וחוקי בטיחות, קיים איסור להשתמש בכבלים המוסמכים ב- UL או ב- CSA (כשאר מופיע עליהם קוד של UL/CSA) עבור כל מוצר חשמלי אחר שלא צויין על ידי סופרמיקרו בלבד.

عند تركيب الجهاز يجب استخدام كابلات التوصيل، والكابلات الكهربائية
ومحولات التيار المتردد

التي . أن استخدام أي كابلات ومحولات أخرى يتسبب في حدوث عطل أو حريق.
تم توفيرها لك مع المنتج

الأجهزة الكهربائية ومواد قانون السلامة يحظر استخدام الكابلات CSA أو UL
معتمدة من قبل

لأي أجهزة كهربائية أخرى غير المنتجات المعينة من قبل Supermicro
(التي تحمل علامة UL/CSA)

경고!

제품을 설치할 때에는 제공되거나 지정된 연결케이블과 전원케이블, AC 어댑터를 사용해야 합니다. 그 밖의 다른 케이블들이나 어댑터들은 고장 또는 화재의 원인이 될 수 있습니다. 전기용품안전법 (Electrical Appliance and Material Safety Law)은 슈퍼마이크로에서 지정한 제품들 외에는 그 밖의 다른 전기 장치들을 위한 UL 또는 CSA에서 인증한 케이블(전선 위에 UL/CSA가 표시)들의 사용을 금지합니다.

Waarschuwing

Bij het installeren van het product, gebruik de meegeleverde of aangewezen kabels, stroomkabels en adapters. Het gebruik van andere kabels en adapters kan leiden tot een storing of een brand. Elektrisch apparaat en veiligheidsinformatiebladen wet verbiedt het gebruik van UL of CSA gecertificeerde kabels die UL of CSA die op de code voor andere elektrische apparaten dan de producten die door Supermicro alleen.

Chapter 5

Advanced Motherboard Setup

This chapter covers the steps required to install the X10DRFF-CG/CTG motherboard into the chassis, connect the data and power cables and install add-on cards. All motherboard jumpers and connections are also described. A layout and quick reference chart are included in this chapter for your reference. Remember to completely close the chassis when you have finished working with the motherboard to better cool and protect the system.

5-1 Handling the Motherboard

Electrostatic Discharge (ESD) can damage electronic components. To prevent damage to any printed circuit boards (PCBs), it is important to handle them very carefully (see previous chapter). To prevent the motherboard from bending, keep one hand under the center of the board to support it when handling. The following measures are generally sufficient to protect your equipment from electric static discharge.

Precautions

- Use a grounded wrist strap designed to prevent Electrostatic Discharge (ESD).
- Touch a grounded metal object before removing any board from its antistatic bag.
- Handle a board by its edges only; do not touch its components, peripheral chips, memory modules or gold contacts.
- When handling chips or modules, avoid touching their pins.
- Put the motherboard, add-on cards and peripherals back into their antistatic bags when not in use.
- For grounding purposes, make sure your computer chassis provides excellent conductivity between the power supply, the case, the mounting fasteners and the motherboard.

Unpacking

The motherboard is shipped in antistatic packaging to avoid electrical static discharge. When unpacking the board, make sure the person handling it is static protected.

5-2 Connecting Cables

Now that the processors are installed, the next step is to connect the cables to the serverboard.

Connecting Data Cables

The cables used to transfer data from the peripheral devices have been carefully routed in preconfigured systems to prevent them from blocking the flow of cooling air that moves through the system from front to back. If you need to disconnect any of these cables, you should take care to reroute them as they were originally after reconnecting them (make sure the red wires connect to the pin 1 locations). If you are configuring the system, keep the airflow in mind when routing the cables.

5-3 Control Panel Connectors and I/O Ports

The rear I/O ports are color coded in conformance with the PC 99 specification. See Figure 5-1 below for the colors and locations of the various I/O ports.

Figure 5-1. Front I/O Ports

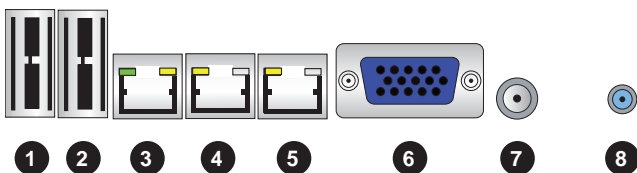

Back Panel I/O Port Locations and Definitions	
1	JUSB1: for Rear USB 2.0 Port 0 or Rear USB 3.0 Port 1
2	JUSB2: for Rear USB 2.0 Port 1 or Rear USB 3.0 Port 2
3	IPMI_Dedicated LAN
4	Gigabit LAN Port 1 (for X10DRFF-CG), 10GBase-T LAN Port 1 (for X10DRFF-CTG)
5	Gigabit LAN Port 2 (for X10DRFF-CG), 10GBase-T LAN Port 2 (for X10DRFF-CTG)
6	VGA Port
7	Power Switch
8	UID (Unit Identified) Button

5-4 Processor and Heatsink Installation

Warning! When handling the processor package, avoid placing direct pressure on the label area.

Warning! If you buy a CPU separately, make sure that you use an Intel-certified multi-directional heatsink only.

Notes:

1. Always connect the power cord last, and always remove it before adding, removing or changing any hardware components. Make sure that you install the processor into the CPU socket before you install the CPU heatsink.
2. Make sure to install the system board into the chassis before you install the CPU heatsink.
3. When receiving a server board without a processor pre-installed, make sure that the plastic CPU socket cap is in place and none of the socket pins are bent; otherwise, contact your retailer immediately.
4. Refer to the Supermicro website for updates on CPU support.
5. When only one CPU is installed, be sure to install it on CPU Socket 1 first.

Installing the LGA2011 Processor

1. There are two load levers on the LGA2011 socket. To open the socket cover, first press and release the load lever labeled 'Open 1st'.

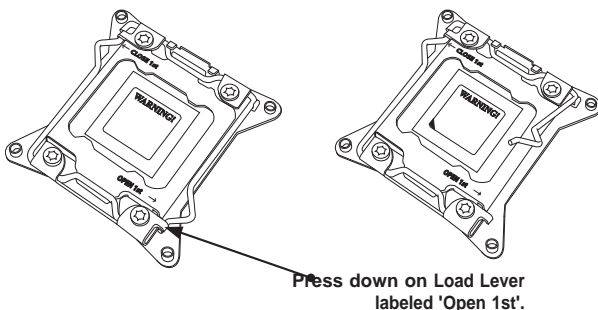

Note: Graphics and drawings shown in this manual are for illustration only. Your components may or may not look the same as the graphics shown in the manual.

2. Press the second load lever labeled 'Close 1st' to release the load plate that covers the CPU socket from its locking position.

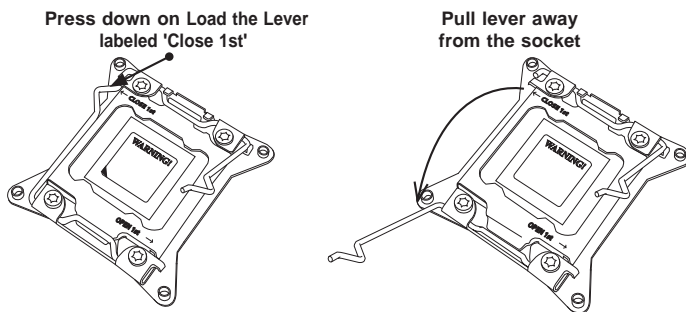

3. With the lever labeled 'Close 1st' fully retracted, gently push down on the 'Open 1st' lever to open the load plate. Lift the load plate to open it completely.

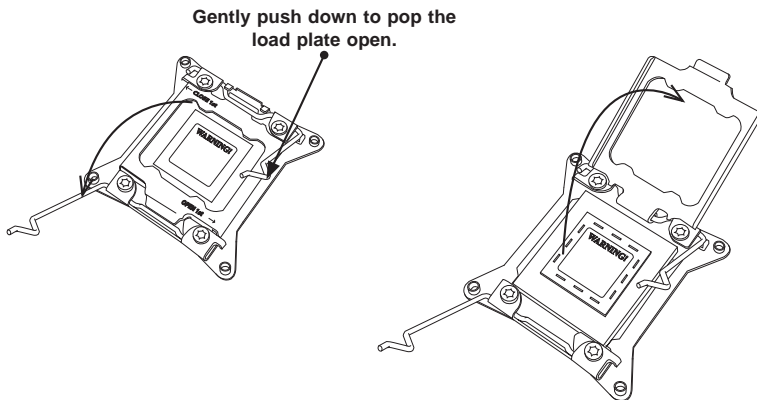

4. Using your thumb and the index finger, remove the 'WARNING' plastic cap from the socket.

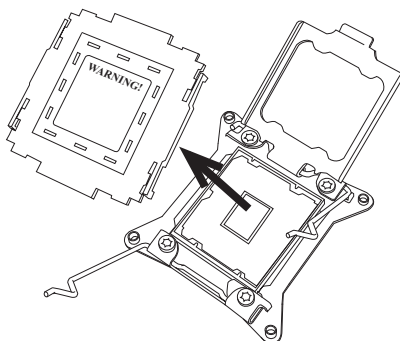

5. Use your thumb and index finger to hold the CPU on its edges. Align the CPU keys, which are semi-circle cutouts, against the socket keys.

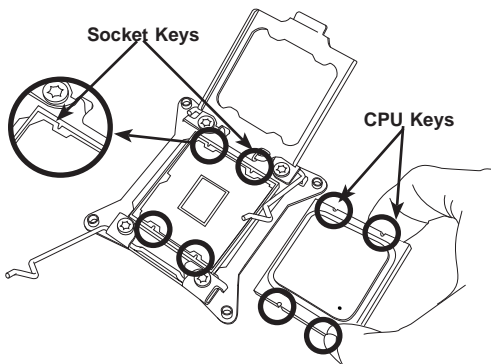

6. Once they are aligned, carefully lower the CPU straight down into the socket. (Do not drop the CPU on the socket. Do not move the CPU horizontally or vertically. Do not rub the CPU against the surface or against any pins of the socket to avoid damaging the CPU or the socket.)

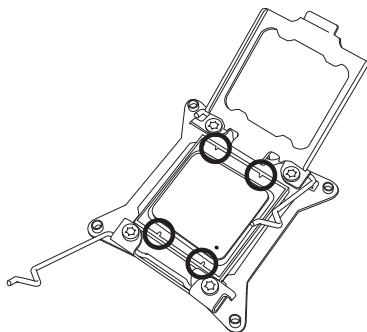

Caution: You can only install the CPU inside the socket in one direction. Make sure that it is properly inserted into the CPU socket before closing the load plate. If it doesn't close properly, do not force it as it may damage your CPU. Instead, open the load plate again and double-check that the CPU is aligned properly.

7. With the CPU inside the socket, inspect the four corners of the CPU to make sure that the CPU is properly installed.

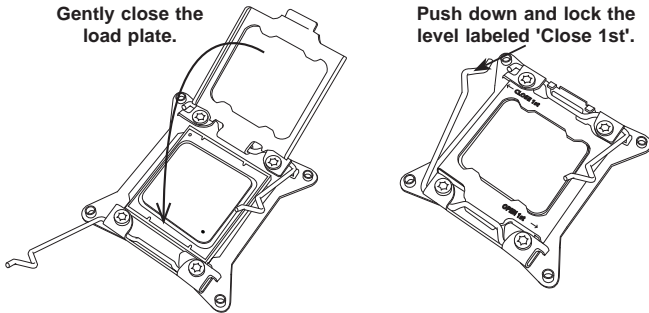

8. Close the load plate with the CPU inside the socket. Lock the lever labeled 'Close 1st' first, then lock the lever labeled 'Open 1st' second. Use your thumb to gently push the load levers down to the lever locks.

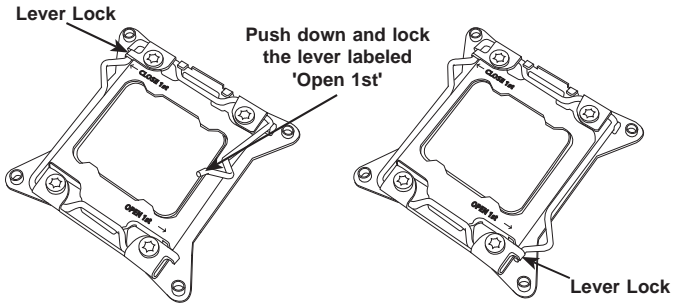

Installing a Passive CPU Heatsink

1. Apply the proper amount of thermal grease to the heatsink.
2. Place the heatsink on top of the CPU so that the two mounting holes on the heatsink are aligned with those on the retention mechanism.
3. Insert two push-pins on the sides of the heatsink through the mounting holes on the motherboard, and turn the push-pins clockwise to lock them.

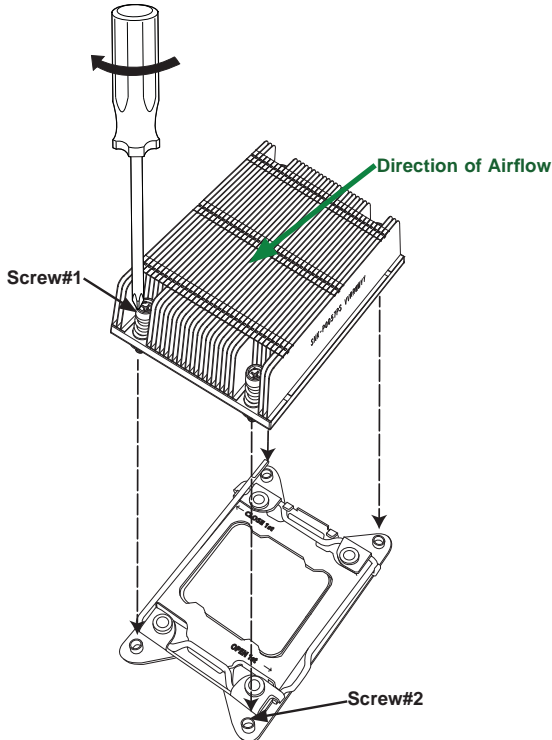

Note: For optimized airflow, please follow your chassis airflow direction to properly install the correct heatsink. Graphics included in this manual are for reference only. They might look different from the components installed in your system.

Removing the Passive Heatsink

Warning: We do not recommend that the CPU or the heatsink be removed. However, if you do need to remove the heatsink, please follow the instructions below to uninstall the heatsink to avoid damaging the CPU or other components.

1. Unplug the power cord from the power supply.
2. Press down the push-pin on the heatsink, and turn counter-clock-wise to loosen it. Repeat the same step to loosen the second push-pin.
3. Hold the heatsink as shown in the picture below, and gently wriggle the heatsink to loosen it. (Do not use excessive force when wriggling the heatsink.)
4. Once the heatsink is loosened, remove it from the motherboard.

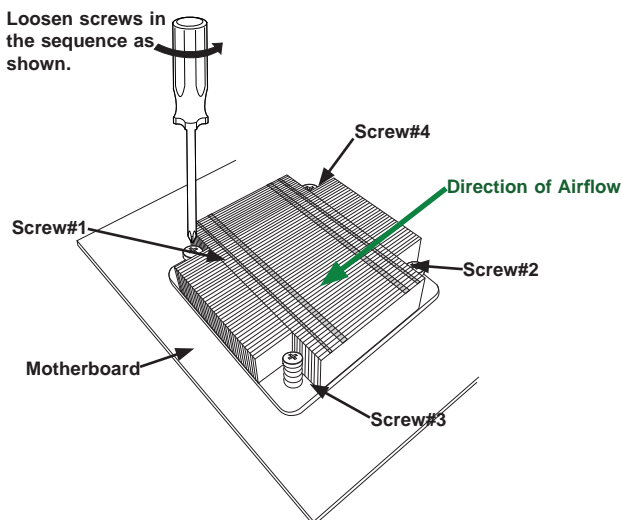

Note: For optimized airflow, please follow your chassis airflow direction to properly install the heatsink. Graphics included in this manual are for reference only. They might look different from the components installed in your system.

5-5 Installing Memory

Caution: exercise extreme care when installing or removing DIMM modules to prevent any possible damage.

Installing Memory

1. Insert the desired number of DIMMs into the memory slots, starting with P1-DIMM #A1. (For best performance, please use the memory modules of the same type and speed in the same bank.)
2. Push the release tabs outwards on both ends of the DIMM slot to unlock it.
3. Align the key of the DIMM module with the receptive point on the memory slot.
4. Align the notches on both ends of the module against the receptive points on the ends of the slot.
5. Use two thumbs together to press the notches on both ends of the module straight down into the slot until the module snaps into place.
6. Press the release tabs to the locking positions to secure the DIMM module into the slot.

Reverse the steps above to remove the DIMM modules from the motherboard.

Note: 1 GB, 2 GB, 4 GB, 8 GB, 16 GB, 32 GB or 64 GB size memory modules are supported. It is highly recommended that you remove the power cord from the system before installing or changing memory modules. Please refer to our web site for memory that has been tested on the X10DRFF-CG/CTG serverboard.

Figure 5-2. Installing DIMM into Slot

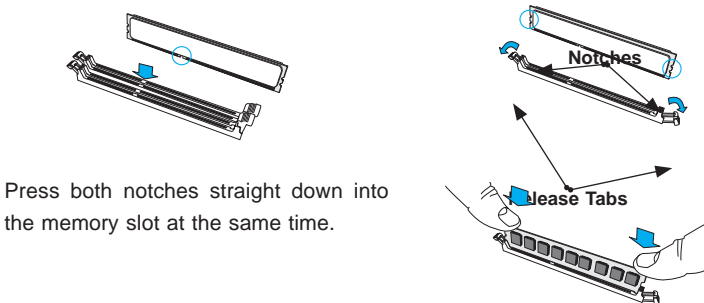

Removing Memory Modules

Press the release tabs on both ends of the memory module to unlock it. Once it is loosened, remove the DIMM module from the memory slot.

Memory Support

The X10DRFF-CG/CTG motherboard supports up to 1024 GB of Load Reduced (LRDIMM) or up to 512 GB of Registered (RDIMM) DDR4 (288-pin) ECC DDR4-2133/1866/1600 MHz memory modules in sixteen (16) slots (with 1 DIMM per channel). Memory speed support is pending on the processors used in the system.

Note: For the latest CPU/memory updates, please refer to our website at <http://www.supermicro.com/products/motherboard>.

Processors and their Corresponding Memory Modules								
CPU#	Corresponding DIMM Modules							
CPU 1	P1-DIMMA1	P1-DIMMB1	P1-DIMMC1	P1-DIMMD1	P1-DIMMA2	P1-DIMMB2	P1-DIMMC2	P1-DIMMD2
CPU2	P2-DIMME1	P2-DIMMF1	P2-DIMMG1	P2-DIMMH1	P2-DIMME2	P2-DIMMF2	P2-DIMMG2	P2-DIMMH2

Processor and Memory Module Population for Optimal Performance	
Number of CPUs+DIMMs	CPU and Memory Population Configuration Table (For memory to work properly, please follow the instructions below.)
1 CPU & 2 DIMMs	CPU1 P1-DIMMA1/P1-DIMMB1
1 CPU & 4 DIMMs	CPU1 P1-DIMMA1/P1-DIMMB1, P1-DIMMC1/P1-DIMMD1
1 CPU & 5-8 DIMMs	CPU1 P1-DIMMA1/P1-DIMMB1, P1-DIMMC1/P1-DIMMD1 + any pair of P1-DIMMA2/P1-DIMMB2/P1-DIMMC2/P1-DIMMD2 slots
2 CPUs & 4 DIMMs	CPU1 + CPU2 P1-DIMMA1/P1-DIMMB1, P2-DIMME1/P2-DIMMF1
2 CPUs & 6 DIMMs	CPU1 + CPU2 P1-DIMMA1/P1-DIMMB1/P1-DIMMC1/P1-DIMMD1, P2-DIMME1/P2-DIMMF1
2 CPUs & 8 DIMMs	CPU1 + CPU2 P1-DIMMA1/P1-DIMMB1/P1-DIMMC1/P1-DIMMD1, P2-DIMME1/P2-DIMMF1/P2-DIMMG1/P2-DIMMH1
2 CPUs & 9-16 DIMMs	CPU1/CPU2 P1-DIMMA1/P1-DIMMB1/P1-DIMMC1/P1-DIMMD1, P2-DIMME1/P2-DIMMF1/P2-DIMMG1/P2-DIMMH1 + any pair of P1, P2 DIMM slots
2 CPUs & 16 DIMMs	CPU1/CPU2 P1-DIMMA1/P1-DIMMB1/P1-DIMMC1/P1-DIMMD1, P2-DIMME1/P2-DIMMF1/P2-DIMMG1/P2-DIMMH1, P1-DIMMA2/P1-DIMMB2/P1-DIMMC2/P1-DIMMD2, P2-DIMME2/P2-DIMMF2/P2-DIMMG2/P2-DIMMH2

Populating Memory Modules

Intel E5-2600v3 Series Processor Memory Support						
Type	Ranks Per DIMM & Data Width (See the Note Below)	Memory Capacity Per DIMM		Speed (MT/s) and Voltage (V)		
				1 Slot Per Channel	2 Slots Per Channel	
				1DPC	1DPC	2DPC
		4 GB	8 GB	1.2V	1.2V	1.2V
RDIMM	SRx4	8 GB	16 GB	2133	2133	1866
RDIMM	SRx8	4 GB	8 GB	2133	2133	1866
RDIMM	DRx8	8 GB	16 GB	2133	2133	1866
RDIMM	DRx4	16 GB	32 GB	2133	2133	1866
LRDIMM	QRx4	32 GB	64 GB	2133	2133	2133

Note: For detailed information on memory support and updates, please refer to the SMC Recommended Memory List posted on our website at <http://www.supermicro.com/support/resources/mem.cfm>.

Other Important Notes and Restrictions

- For the memory modules to work properly, please install DIMM modules in pairs (w/even number of DIMMs installed).
- Mixing memory modules of different types, different speeds or different sizes is not allowed.

Notes:

1. For the latest CPU/Memory updates, please refer to our website at <http://www.supermicro.com/products/motherboard/> for details.
2. Use only the correct type of onboard CMOS battery as specified by the manufacturer. Do not install the onboard battery upside down to avoid possible explosion.
3. Components/Jumpers/LED Indicators that are not documented in this manual are reserved for internal testing only.

X10DRFF-CG/CTG Motherboard Jumpers

Jumper	Description	Default Setting
JBT1	Clear CMOS/Reset BIOS Configuration	See Chapter 2
JPB1	BMC Enabled	Pins 1-2 (Enabled)
JPG1	VGA Enabled	Pins 1-2 (Enabled)
JPL1	GLAN1/GLAN2 Enable (X10DRFF-CG) or 10G TLAN1/TLAN2 Enable (X10DRFF-CTG)	Pins 1-2 (Enabled)
JPME2	Manufacture Mode (ME) Select	Pins 1-2 (Normal)
JWD1	Watch Dog	Pins 1-2 (Reset)

X10DRFF-CG/CTG Motherboard LED Indicators

LED	Description	State
HDD_LED1	HDD Activity LED	Green: Blinking (HDD Active)
Failure_LED2	Motherboard Failure LED	Solid: On (Overheating) Blinking at 1Hz (Fan Failure) Blinking at 0.25Hz (Power Supply Failure)
LEDBMC	BMC Heartbeat LED	Green: Blinking (BMC Normal)
LEDS2	SAS Activity LED	Green: Blinking (SAS Active)
UID_LED1	Rear UID LED	Blue: On (Unit Identified)

X10DRFF-CG/CTG Motherboard Connectors

Connectors	Description
BT1 (Battery)	Onboard CMOS battery (See Chpt. 3 for Used Battery Disposal)
COM1	Serial port header
FAN1-8, Rear FAN1/2	CPU/system fan headers (Fan 1-Fan 8, Rear Fan1/Rear Fan1)
HDD PWR1/2	8-pin power connectors (1/2) for HDD devices
IPMI_LAN	IPMI_dedicated LAN support by the ASpeed controller
LAN1/LAN2	Gigabit Ethernet (GLAN) ports 1/2 (X10DRFF-CG) 10G-bit Ethernet (TLAN) ports 1/2 (X10DRFF-CTG)
JIPMB1	4-pin external BMC I ² C header (for an IPMI card)
JL1	Chassis intrusion header
JNVI ² C1/2	System management bus (SMBbus) (I ² C) for Non-Volatile (NV) memory
JPI ² C1	Power supply SMBbus I ² C header
JPW3	4-pin (PS_ON_N) power connector
JPW1/JPW2	12V 8-pin power connectors 1/2
JTPM1	TPM (Trusted Platform Module)/Port 80 header
JUIDB1	UID (Unit Identification) switch
JVRM1/2	VRM headers 1/2
PWR_SW1	Power switch
I-SATA 0-5	SATA 3.0 connectors supported by Intel PCH (I-SATA 0-5), (I-SATA4/I-SATA5: can be used as Supermicro SuperDOM (Disk-on-Module) with built-in power connectors)
S-SATA 0-3	SATA 3.0 connectors (0-3) supported by Intel PCH
SAS(0-3,4-7)(for X10DRFF-CG/CTG)	SAS 3.0 connections (0-3, 4-7) supported by the LSI 3008
S-SGPIO1	Seria_Link General Purpose I/O header for S-SATA ports (S-SATA0-3)
T-SGPIO1/2	Seria_Link General Purpose I/O headers 1/2 for SATA ports (I-SGPIO1 for I-SATA0-3, I-SGPIO2 for I-SATA4/5)
(CPU1) Slot2	PCI-Express 3.0 x8 slot from CPU1
(CPU2) Slot3	PCI-Express 3.0 x8 slot from CPU2
(PCH) Slot4	PCI-Express 2.0 x4 slot from PCH
SXB1 Slot1	CPU1 SLOT1 PCI-E x16 Proprietary Slot
SXB2 Slot2	CPU1 SLOT2 PCI-E x32 Proprietary Slot
(BP) USB 12/13 (3.0)	Backpanel USB 3.0 ports 12/13 (USB0/1)
VGA	Backpanel VGA port

5-7 Connector Definitions

Power Connectors

Two 8-pin power connectors (JPW1/JPW2) provide main power to the motherboard, while other two 8-pin power connectors (HDD_PWR1/HDD_PWR2) are used to supply power to HDD devices. The 4-pin power connector (JPW3) is used as auxiliary power. These power connectors provide adequate power to the system. See the tables on the right for pin definitions.

12V 8-pin Power Connector (JPW1/JPW2) Pin Definitions	
Pins	Definition
1 through 4	Ground
5 through 8	+12V

12V 8-pin HDD PWR Connector (HDD_PWR1/2HDD) Pin Definitions	
Pins	Definition
1	+12V
2-3	Ground
4	+5V

Warning: To ensure adequate power supply to your motherboard, be sure to connect all the power connectors mentioned above to your power supply. For proper system operation.

Universal Serial Bus (USB)

Two USB ports (USB 12/13) are located on the I/O back panel to provide USB 3.0 connections to the system. (Cables are not included.) See the tables on the right and below for pin definitions.

Back Panel USB 12/13 (3.0) Pin Definitions	
Pin#	Description
1	VBUS
2	SSRX-
3	SSRX+
4	Ground
5	SSTX-
6	SSTX+
7	GND_DRAIN
8	D-
9	D+

Power Switch

A power switch is located next to the VGA port on the IO back panel. Press this switch to turn on or turn off the system power. See the layout below for the location of the power switch.

Unit Identifier Button/UID LED Indicators

A rear Unit Identifier (JUIDB1) button and a UID LED (UID_LED1) are located next to the VGA port on the IO back panel. When you press the rear UID button, rear UID LED will be turned on. Press the UID button again to turn off the LED indicator. The UID indicator provides easy identification of a system unit that may be in need of service.

Note: UID can also be triggered via IPMI on the motherboard. For more information on IPMI, please refer to the IPMI user's guide posted on our website @ <http://www.supermicro.com>.

UID Switch (JUIDB1)	
Pin#	Definition
1	Ground
2	Ground
3	Button In
4	Ground

UID LED Status (UID_LED1)	
Color/State	Status
Blue: On	Unit Identified

Chassis Intrusion

A Chassis Intrusion header is located at JL1 on the motherboard. Attach an appropriate cable from the chassis to inform you of a chassis intrusion when the chassis is opened.

Chassis Intrusion (JL1) Pin Definitions	
Pin#	Definition
1	Intrusion Input
2	Ground

Serial Port Header

A COM port header is located next to the DIMM memory P1-DIMMC1 slot on the serverboard. COM1 provides serial connection support.

Ethernet Ports

Two Ethernet ports (LAN1/2) are located on the I/O back panel on the motherboard. These two LAN ports support Gigabit LAN connections. In addition, an IPMI-dedicated LAN, located next to LAN 2 on the back panel, provides IPMI KVM support. All these ports accept RJ45 type cables. (Note: Please refer to the LED Indicator Section for LAN LED information.)

Video Connector

A Video (VGA) connector is located next to IPMI_LAN on the IO back panel. This connector provides video and CRT display. Refer to the board layout below for the location.

Fan Headers

This motherboard has ten system/CPU fan headers (Fans 1-8, Rear Fan 1, and Rear Fan 2) on the motherboard. All these 4-pin fans headers are backward-compatible with the traditional 3-pin fans. However, fan speed control is available for 4-pin fans only by Thermal Management via the IPMI 2.0 interface. See the table on the right for pin definitions.

Fan Header Pin Definitions	
Pin#	Definition
1	Ground
2	+12V
3	Tachometer
4	PWR Modulation

TPM Header/Port 80

A Trusted Platform Module (TPM)/Port 80 header is located at JTPM1 to provide TPM support and Port 80 connections. Use this header to enhance system performance and data security. See the table on the right for pin definitions.

TPM/Port 80 Header (JTPM1) Pin Definitions			
Pin#	Definition	Pin#	Definition
1	LCLK	2	GND
3	LFRAME#	4	<(KEY)>
5	LRESET#	6	No Connection
7	LAD 3	8	LAD 2
9	+3.3V	10	LAD1
11	LAD0	12	GND
13	No Connection	14	No Connection
15	+3V_DUAL	16	SERIRQ
17	GND	18	CLKRUN# (X)
19	LPCPD#	20	No Connection

DOM Power Connectors

Two power connectors for SATA DOM (Disk_On_Module) devices are located at JSD1/JSD2. Connect appropriate cables here to provide power support for your Serial Link DOM devices.

DOM PWR (JSD1/2) Pin Definitions	
Pin#	Definition
1	+5V
2	Ground
3	Ground

Power SMB (I²C) Connector

The Power System Management Bus (I²C) connector (JPI²C1) monitors power supply, fan, and system temperatures. See the table on the right for pin definitions.

PWR SMB Connector (JPI ² C1) Pin Definitions	
Pin#	Definition
1	Clock
2	Data
3	PMBUS_Alert
4	Ground
5	+3.3V

IPMB I²C SMB

A System Management Bus header for IPMI 2.0 is located at JIPMB1. Connect the appropriate cable here to use the IPMB I²C connection on your system.

SMB Header (JIPMB1) Pin Definitions	
Pin#	Definition
1	Data
2	Ground
3	Clock
4	No Connection

T-SGPIO 1/2 & S-SGPIO 1 Headers

Three SGPIO (Serial Link General Purpose Input/Output) headers are located on the motherboard. T-SGPIO1/2 support onboard I-SATA 0-5, while S-SGPIO1 supports S-SATA 0-3 connections. See the tables on the right for SGPIO support and for pin definitions of the connectors.

T-SGPIO1/2, S-SGPIO Pin Definitions			
Pin#	Definition	Pin#	Definition
1	NC	2	NC
3	Ground	4	Data
5	Load	6	Ground
7	Clock	8	NC

NC indicates no connection.

I-SGPIO 0/1	
T-SGPIO1	I-SATA 3.0 ports 0-3 Supported
T-SGPIO2	I-SATA 3.0 ports 4/5 Supported
S-SGPIO1	S-SATA 3.0 ports 0-3 Supported

5-8 Jumper Settings

Explanation of Jumpers

To modify the operation of the motherboard, jumpers can be used to choose between optional settings. Jumpers create shorts between two pins to change the function of the connector. Pin 1 is identified with a square solder pad on the printed circuit board. See the diagram at right for an example of jumping pins 1 and 2. Refer to the motherboard layout page for jumper locations.

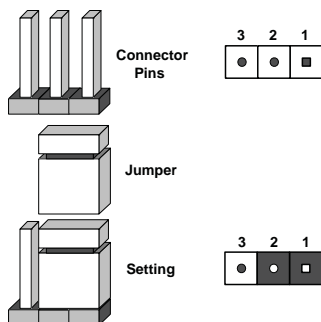

Note: On two-pin jumpers, "Closed" means the jumper is on and "Open" means the jumper is off the pins.

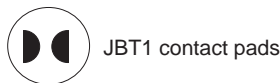

JBT1 contact pads

CMOS Clear

JBT1 is used to clear CMOS, which will also clear any passwords. Instead of pins, this jumper consists of contact pads to prevent accidentally clearing the contents of CMOS.

To Clear CMOS

1. First power down the system and unplug the power cord(s). It is also recommended that you remove the onboard battery from the serverboard.
2. With the power disconnected, short the CMOS pads with a metal object such as a small screwdriver.
3. Remove the screwdriver (or shorting device).
4. Reconnect the power cord(s) and power on the system.

Note 1. For an ATX power supply, you must completely shut down the system, remove the AC power cord, and then short JBT1 to clear CMOS.

Note 2. Be sure to remove the onboard CMOS Battery before you short JBT1 to clear CMOS.

Note 3. Clearing CMOS will also clear all passwords.

Note 4: Do not use the PW ON connector to clear CMOS.

LAN Enable/Disable

JPL1 enables or disables GbE LAN ports 1/2 on the X10DRFF-iG/CG and 10GbE LAN ports 1/2 on the X10DRFF-iTG/CTG. See the table on the right for jumper settings. The default setting is Enabled.

LAN Enable (JPL1) Jumper Settings	
Jumper Setting	Definition
Pins 1-2	Enabled (Default)
Pins 2-3	Disabled

Watch Dog Enable/Disable

The Watch Dog (JWD1) is a system monitor that will reboot the system when a software application hangs. Close pins 1-2 to reset the system if an application hangs. Close pins 2-3 to generate a non-maskable interrupt signal for the application that hangs. See the table on the right for jumper settings. The Watch Dog must also be enabled in the BIOS.

Watch Dog (JWD1) Jumper Settings	
Jumper Setting	Definition
Pins 1-2	Reset (Default)
Pins 2-3	NMI
Open	Disabled

VGA Enable

Jumper JPG1 allows the user to enable the onboard VGA connector. The default setting is on pins 1-2 to enable the connection. See the table on the right for jumper settings.

VGA Enable (JPG1) Jumper Settings	
Jumper Setting	Definition
Pins 1-2	Enabled (Default)
Pins 2-3	Disabled

BMC Enable

Jumper JPB1 allows you to enable the embedded ASpeed AST2400 Baseboard Management Controller (BMC) to provide IPMI 2.0/KVM support on the motherboard. See the table on the right for jumper settings.

BMC Enable (JPB1) Jumper Settings	
Jumper Setting	Definition
Pins 1-2	BMC Enable (Default)
Pins 2-3	Disabled

Manufacturer Mode Select

Close pin 2 and pin 3 of Jumper JPME2 to bypass SPI flash security and force the system to operate in the manufacturer mode, which will allow the user to flash the system firmware from a host server for system setting modifications. See the table on the right for jumper settings.

ME Mode Select (JPME2) Jumper Settings	
Jumper Setting	Definition
Pins 1-2	Normal (Default)
Pins 2-3	Manufacture Mode

5-9 Onboard Indicators

LAN LEDs

The Ethernet LAN port is located on the IO Backplane on the motherboard. Each LAN port has two LEDs. The Yellow LED indicates activity. The Link LED on the left side of the LAN port may be green, amber or off to indicate the speed of the connection. See the tables on the right for more information.

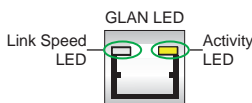

LAN Port Activity LED (Left) LED State		
Color	Status	Definition
Orange	Flashing	Active

1Gbps LAN Link LED Settings (For X10DRFF-CG MB Only)	
Color	Definition
Off	No Connection, 10 Mbps
Green	100 Mbps
Amber	1 Gbps

10Gbps LAN Link LED Settings (For X10DRFF-CTG MB Only)	
Color	Definition
Off	No Connection, 10 or 100 Mbps
Green	10 Gbps
Amber	1 Gbps

IPMI Dedicated LAN LEDs

In addition to the LAN Port 1, an IPMI Dedicated LAN is also located on the I/O Backplane. The amber LED on the right indicates connection and activity; while the green LED on the left indicates the speed of the connection. See the tables at right for more information.

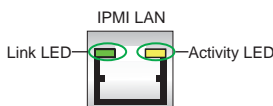

IPMI LAN Link/Speed LED (Left) & Activity LED (Right)		
LED	Color/Status	Definition
Link (Left)	Green: Solid	100 Mbps
	Amber: Solid	1 Gbps
Activity (Right)	Orange: Blinking	Active

HDD Activity LED

The HDD Activity LED is located at HDD_LED1 on the motherboard. When HDD_LED1 is blinking, HDD is active. See the table on the right for more information.

HDD Activity LED Status	
Color/State	Definition
Green: Blinking	HDD: Active

BMC Heartbeat LED

A BMC Heartbeat LED is located at LEDBMC on the motherboard. When LEDBMC is blinking, the BMC is normal. See the table at right for more information.

BMC Heartbeat LED States	
Color/State	Definition
Green: Blinking	BMC: Normal

SAS Activity LED (For X10DRFF-CG/CTG)

The SAS Activity LED is located at LEDS2 on the motherboard. When LEDS2 is blinking, the SAS drive supported by the LSI 3008 controller is active. See the table on the right for more information.

SAS Activity LED Status	
Color/State	Definition
Green: Blinking	SAS: Active

Motherboard Fault LED

The motherboard Fault LED is located at Failure_LED2 on the motherboard. When Failure_LED2 is on or blinking, an error has occurred to the motherboard. See the table on the right for more information.

Motherboard Fault LED Status	
State	Definition
Solid: On	MB overheating
Blinking@1Hz	Fan Failure
Blinking@0.25Hz	Power Supply Failure

5-10 Serial ATA and SAS Connections

SATA 3.0 Connections

Ten SATA 3.0 connections (I-SATA0-5, S-SATA0-3) are located on the motherboard. All these SATA 3.0 ports are supported by the Intel PCH C612. I-SATA4/5, the yellow connectors with power pins built-in, are used with Supermicro SuperDOM (Disk-on-Module) connectors, and do not require external power cables. SuperDOMs are backward-compatible with regular SATA HDDs and SATA DOMs that require external power cables. All SATA ports provide serial-link signal connections, which are faster than the connections of Parallel ATA. See the table on the right for pin definitions.

Note: For more information on the SATA HostRAID configuration, please refer to the Intel SATA HostRAID user's guide posted on our website at <http://www.supermicro.com>.

SAS Ports

Eight SAS ports, supported by the LSI 3008 SAS controller, are located at X10DRFF-CG/CTG. SAS 0-3 and SAS 4-7 support RAID 0, 1 and 10 (Hardware RAID + 2GB cache) from the LSI 3008 SAS controller.

Note: For more information on SAS RAID configuration, please refer to the LSI MegaRAID User's Guide posted on our website @ <http://www.supermicro.com>.

5-11 Installing Drivers

The Supermicro ftp site contains drivers and utilities for your system at <ftp://ftp.supermicro.com>. Some of these must be installed, such as the chipset driver.

After accessing the ftp site, go into the CDR_Images directory and locate the ISO file for your motherboard. Download this file to create a CD/DVD of the drivers and utilities it contains. (You may also use a utility to extract the ISO file if preferred.)

Another option is to go to the Supermicro Website at <http://www.supermicro.com/products/>. Find the product page for your motherboard here, where you may download individual drivers and utilities.

After creating a CD/DVD with the ISO files, insert the disk into the CD/DVD drive on your system and the display shown in Figure 5-4 should appear.

Figure 5-4. Driver/Tool Installation Display Screen

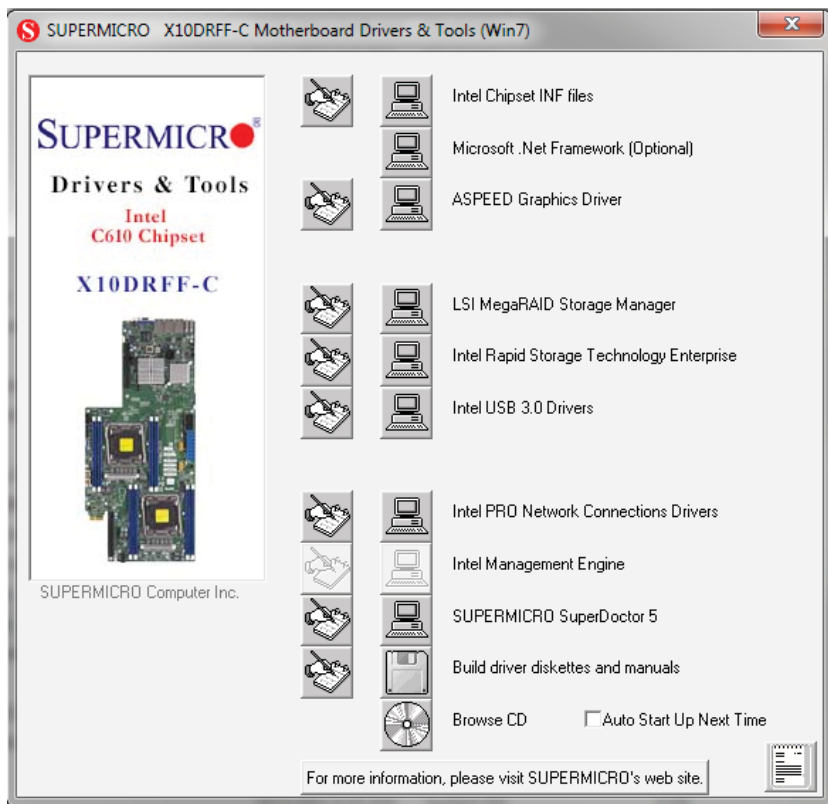

Note: Click the icons showing a hand writing on paper to view the readme files for each item. Click the computer icons to the right of these items to install each item (from top to the bottom) one at a time. **After installing each item, you must re-boot the system before moving on to the next item on the list.** The bottom icon with a CD on it allows you to view the entire contents.

SuperDoctor 5

The Supermicro SuperDoctor® 5 is a hardware and operating system services monitoring program that functions in a command-line or web-based interface in Windows and Linux operating systems. The program monitors system health information such as CPU temperature, system voltages, system power consumption, fan speed, and provides alerts via email or Simple Network Management Protocol (SNMP).

SuperDoctor 5 comes in local and remote management versions and can be used with Nagios to maximize your system monitoring needs. With SuperDoctor 5 Management Server (SSM Server), you can remotely control power on/off and reset chassis intrusion for multiple systems with SuperDoctor 5 or IPMI. SD5 Management Server monitors HTTP, FTP, and SMTP services to optimize the efficiency of your operation.

Note: The default User Name and Password for SuperDoctor 5 is admin / admin.

Figure 5-7. SuperDoctor 5 Interface Display Screen (Health Information)



Figure 5-8. SuperDoctor 5 Interface Display Screen (Remote Control)

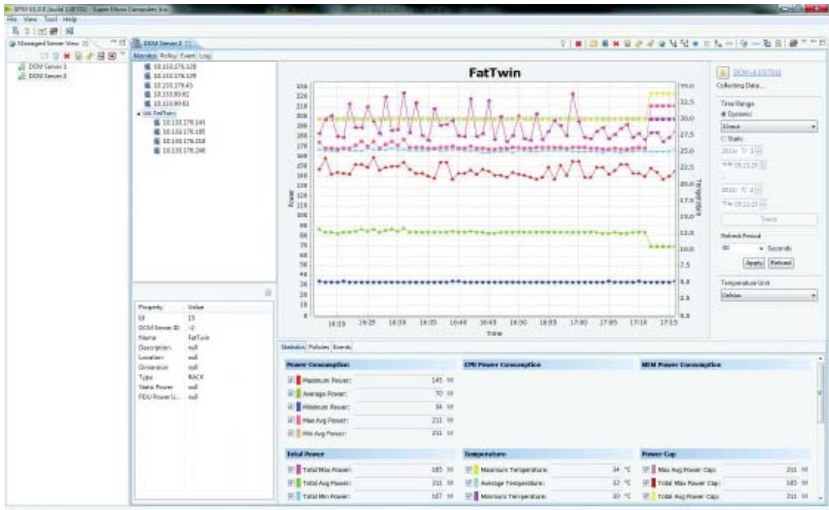

Note: The SuperDoctor 5 program and User's Manual can be downloaded from the Supermicro web site at http://www.supermicro.com/products/info/sms_sd5.cfm. For Linux, we recommend that you use the SuperDoctor II application instead.

5-12 Serverboard Battery

Caution: There is a danger of explosion if the onboard battery is installed upside down, which will reverse its polarities (see Figure 5-7). This battery must be replaced only with the same or an equivalent type recommended by the manufacturer (CR2032). Dispose of used batteries according to the manufacturer's instructions.

Figure 5-7. Installing the Onboard Battery

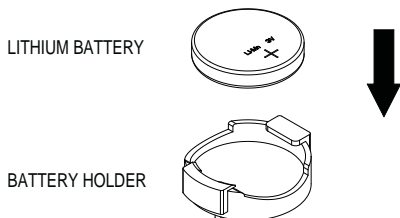

Please handle used batteries carefully. Do not damage the battery in any way; a damaged battery may release hazardous materials into the environment. Do not discard a used battery in the garbage or a public landfill. Please comply with the regulations set up by your local hazardous waste management agency to dispose of your used battery properly.

Chapter 6

Advanced Chassis Setup

This chapter covers the steps required to install components and perform maintenance on the F442BG-R2K04BP chassis. For component installation, follow the steps in the order given to eliminate the most common problems encountered. If some steps are unnecessary, skip ahead to the step that follows.

Tools Required: The only tool you will need to install components and perform maintenance is a Philips screwdriver.

6-1 Static-Sensitive Devices

Electrostatic discharge (ESD) can damage electronic components. To prevent damage to any printed circuit boards (PCBs), it is important to handle them very carefully. The following measures are generally sufficient to protect your equipment from ESD damage.

Precautions

- Use a grounded wrist strap designed to prevent static discharge.
- Touch a grounded metal object before removing any board from its antistatic bag.
- Handle a board by its edges only; do not touch its components, peripheral chips, memory modules or gold contacts.
- When handling chips or modules, avoid touching their pins.
- Put the serverboard, add-on cards and peripherals back into their antistatic bags when not in use.
- For grounding purposes, make sure your computer chassis provides excellent conductivity between the power supply, the case, the mounting fasteners and the serverboard.

Unpacking

The serverboard is shipped in antistatic packaging to avoid static damage. When unpacking the board, make sure the person handling it is static protected.

Figure 6-1. Front and Rear Chassis Views

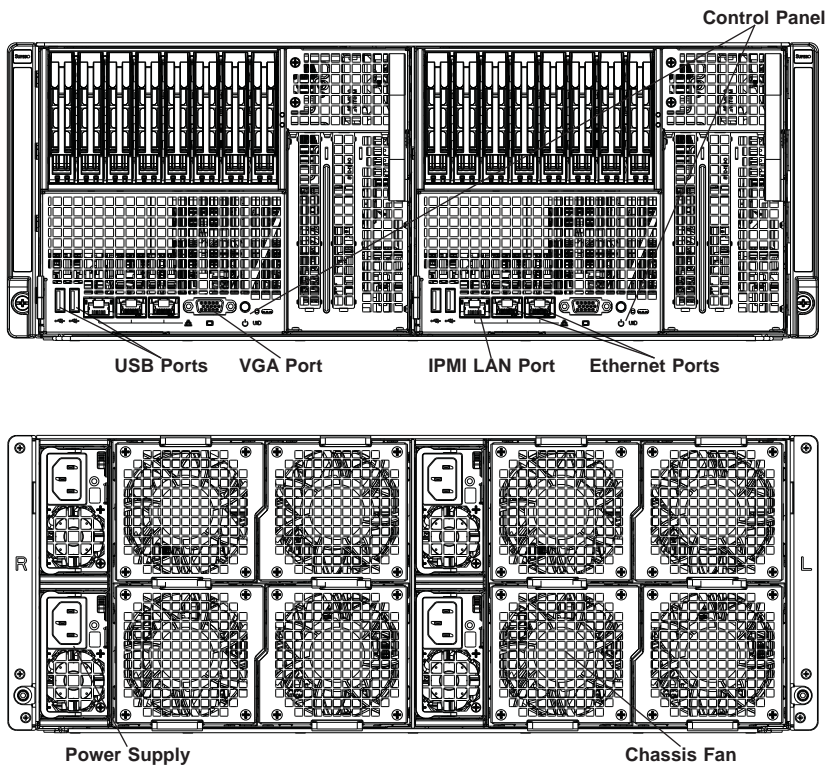

6-2 Control Panel

The control panel for each node is located on the front of the chassis. The LEDs inform you of system status.

See Chapter 3 for details on the LEDs and the control panel buttons.

6-3 Removing the Power Cord

Before performing any setup or maintenance on the chassis, use the following procedure to ensure that power has been removed from the system.

Removing the Power Cord

1. Use the operating system to power down the node, following the on-screen prompts.
2. After the system has completely shut-down, carefully grasp the head of the power cord and gently pull it out of the back of the power supply.
3. If your system has dual redundant power supplies, remove the cords from both power supplies.
4. Disconnect the cord from the power strip or wall outlet.

6-4 Removing Nodes from the Chassis

Each of the two individual serverboard nodes may be removed from the chassis. Note that any time a node is removed from the chassis, the hard drives located in the node will shut-down.

Removing a Serverboard Node

5. Power down the system and remove the power cords from the rear of the node as described in Section 6-3 above.
6. Grasp the node by the handles on either side of the front of the node.
7. Carefully pull the node forward and out of the chassis.

6-5 Installing and Removing Hard Drives

The F442BG chassis contains individual motherboards in separate 4U nodes. Each serverboard node controls the hard drives contained within that node. Note that if a node is pulled out of the chassis, the hard drives associated with that node will power down as well. Only enterprise level hard drives are recommended for use in Supermicro chassis.

F442BG Node Locations in the Chassis	
Node 1 Controls eight 2.5" HDDs, A1-A8	Node 2 Controls eight 2.5" HDDs, B1-B8

Figure 6-2: Hard Drives and the Corresponding Motherboards

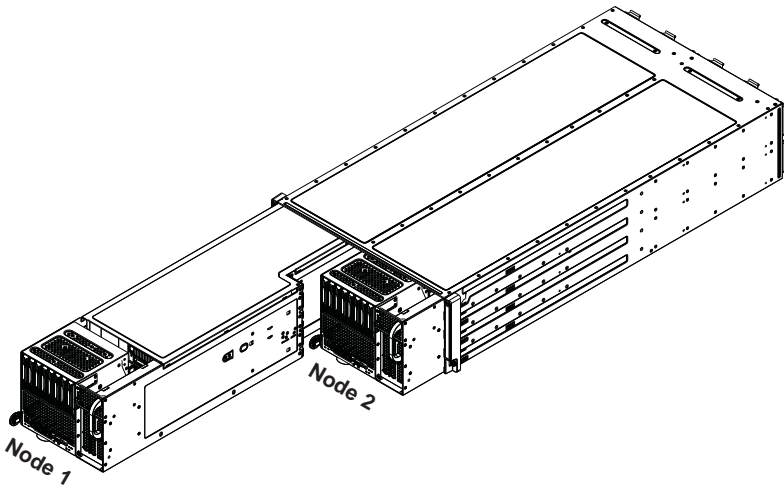

Note: Refer to the following FTP site for RAID setup guidelines: <ftp://ftp.supermicro.com/driver/SAS/LSI/LSI_SAS_EmbMRAID_SWUG.pdf> and Supermicro's web site for additional information <<http://www.supermicro.com/support/manuals/>>.

Removing Hard Drives from the Front of the Node

F442BG models are equipped with eight 2.5" hard drives in each node. These hard drives are hot-swappable and can be removed without powering down the server.

Removing Hard Drive Carriers from the Node

1. Press the release button on the drive carrier. This extends the drive bay handle.
2. Use the handle to pull the drive carrier out of the node.

Figure 6-3: Removing a Hard Drive Carrier from the Front of the Node

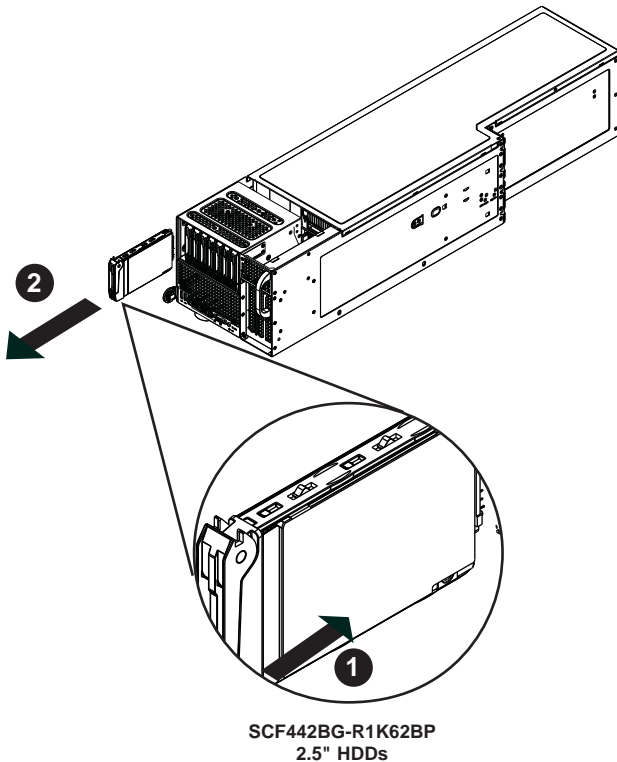

Installing 2.5" Hard Drives into the Drive Carriers

The 2.5" hard drives are mounted in drive carrier to simplify their installation and removal from the chassis. These carriers also help promote proper airflow for the drive bays.

Figure 6-4: 2.5" Hard Drive Carrier

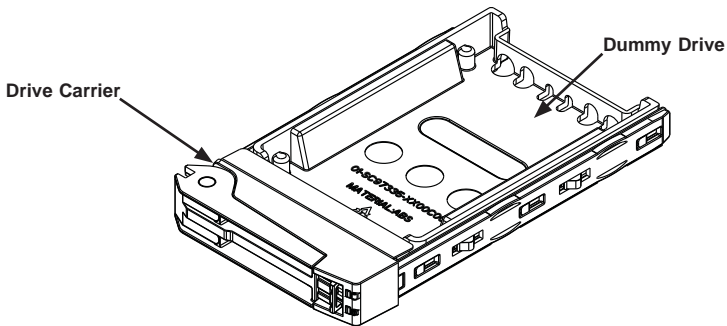

Warning: Except for short periods of time while swapping hard drives, do not operate the server with the hard drives bays empty.

Installing a 2.5" Drive into the Hard Drive Carrier

1. Remove the two screws holding the drive to the carrier.
2. Remove the drive from the carrier.

Figure 6-5 Removing the Dummy Drive from the 2.5" Drive Carrier

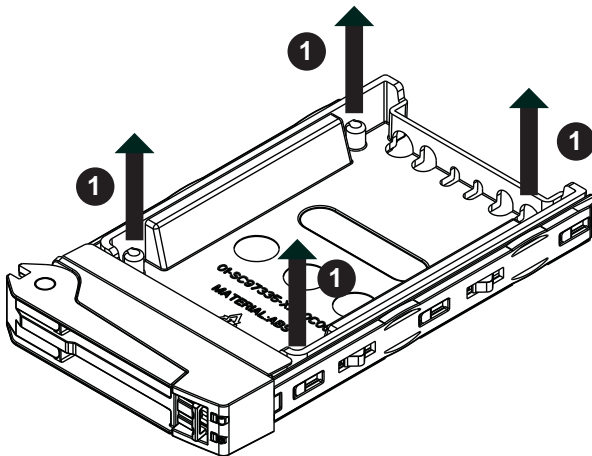

3. Install a new drive into the carrier with the printed circuit board side facing down so that the mounting holes align with those in the carrier.
4. Secure the hard drive by tightening all four screws.
5. Use the open handle to replace the drive carrier into the chassis. Make sure the close the drive carrier handle.

Figure 6-6: Installing a 2.5" Hard Drive in the Drive Carrier

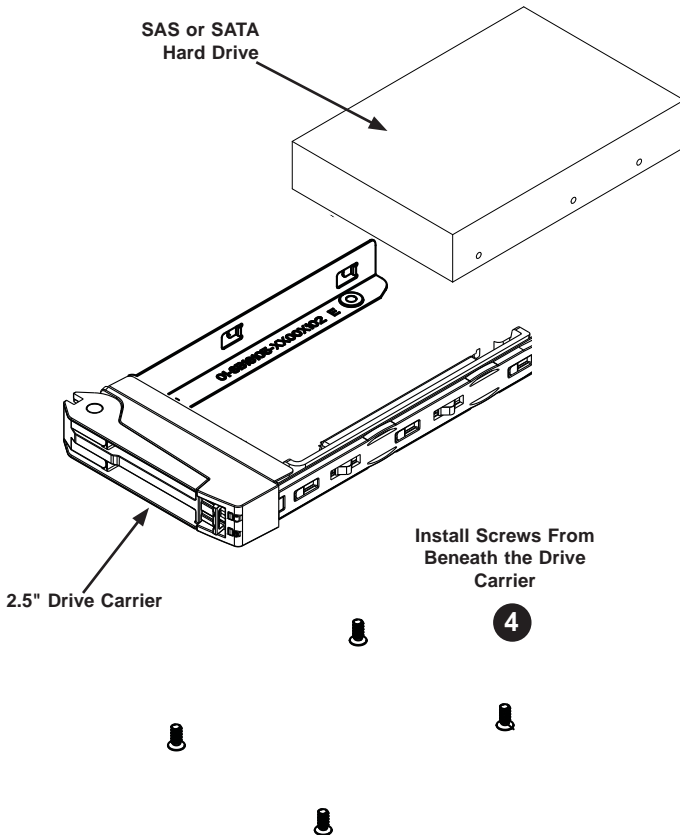

Caution: Enterprise level hard disk drives are recommended for use in Supermicro chassis and servers. For information on recommended HDDs, visit the Supermicro Web site at <http://www.supermicro.com/products/nfo/files/storage/SAS-CompList.pdf>

6-6 Node Configuration

Overview of the Node

F442BG-R2K04BP	
Front of Node	Rear of Node
Two full-height, half-length PCI slots Eight 2.5" HDDs	Four optional fixed fans

Figure 6-7: Front and Rear of the F442BG-R2K04BP

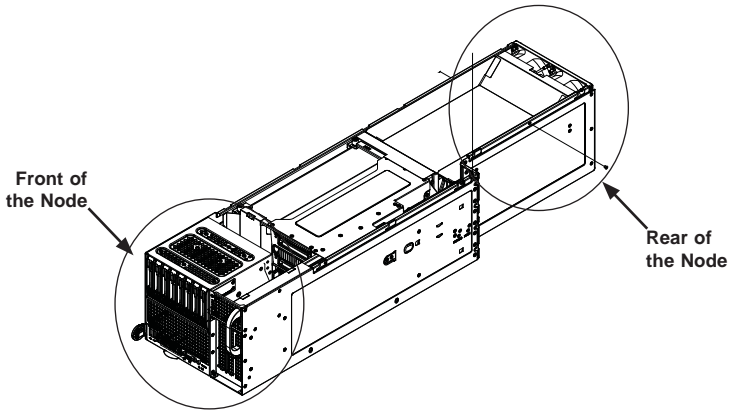

6-7 Removing the Node Cover

Each node has a removable cover which will permit access to the nodes components.

Removing the Node Cover

1. Remove the power cord from the rear of the node and remove the node from the chassis as described in Section 6-3. Remove the node from the chassis as described in Section 6-4. Place the node on a flat, stable surface.
2. Remove the three screws securing the cover to the node, as illustrated above.
3. Lift the cover up and off the node.

Figure 6-8: Removing the Node Cover

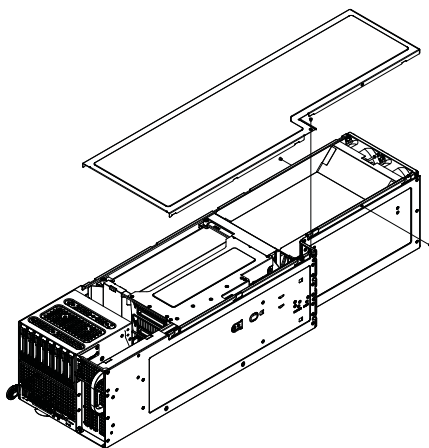

6-8 Removing and Installing the Backplane

The F442BG chassis backplane is located behind the hard drives and in front of the front system fans in each serverboard node. Although backplane failure rarely occurs, in the event of a backplane failure, follow the instructions below.

Removing the Backplane

Removing the Backplane from the Node

1. Remove the power cord from the rear of the node as described in Section 6-3. Remove the node from the chassis as described in Section 6-4. Place the node on a flat, stable surface and remove the node cover as described in Section 6-7.
2. Ensure that all of the hard drive carriers have been removed from the bays in the front of the node (see 6-5 Installing and Removing Hard Drives).
3. Lift the mylar air shroud off the top of the serverboard and remove it from the node as shown in Section 6-13.
4. Remove the screws securing the backplane to the node. The BPN-SAS-I28A backplane has two screws.

Figure 6-9: Removing the Screws from the Backplane

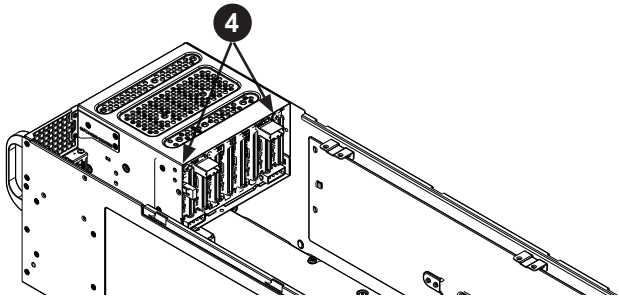

5. Lift the backplane up and out of the node.

Figure 6-10: Removing the Backplane from the Node

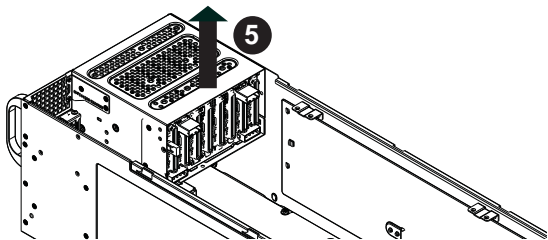

Installing the Backplane

Installing the Backplane into the Node

1. Ensure that all of the hard drive carriers have been removed from the bays in the front of the node (see 6-5 Installing and Removing Hard Drives).
2. Ease the backplane forward, against the front of the node.
3. Align the mounting holes in the backplane with the holes in the chassis. Replace the screws securing the backplane to the Node.

Figure 6-11: Installing the Backplane

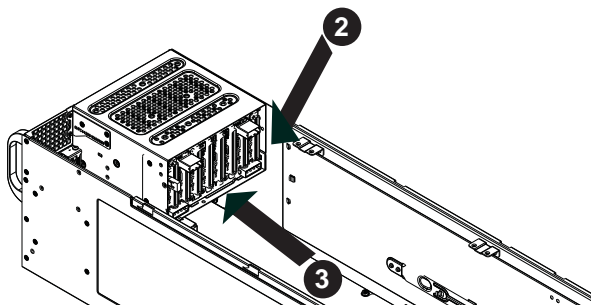

4. Reconnect all cables and return the hard drive trays to their bays in the front of the serverboard node.

Figure 6-12: Removing the Backplane from the Node

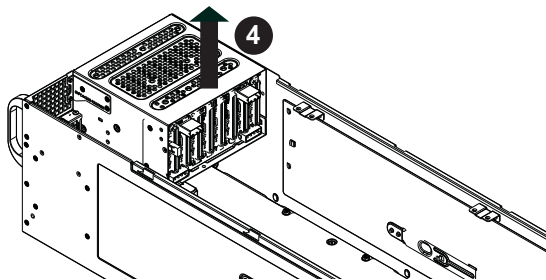

5. Return the air shroud to its position on the serverboard, reinstall the cover onto the node, plug the power cord into the back of the power supply and power up the system.

6-9 Power Adapter Board Replacement

Each of the serverboard nodes includes an upper and lower power adapter board. In the unlikely event of a failure of the power adapter board, replacement is simple and requires only a Phillips head screwdriver.

Changing the Power Adapter Board

1. Remove the power cord from the rear of the node as described in Section 6-3. Remove the node from the chassis as described in Section 6-4. Place the node on a flat, stable surface and remove the node cover as described in Section 6-7.
2. Remove the four screws securing the upper power adapter board to the support bracket.
3. Carefully lift the power adapter board up and out of the node. Set the screws aside for later use.

Figure 6-13: Removing the Upper Power Adapter Board

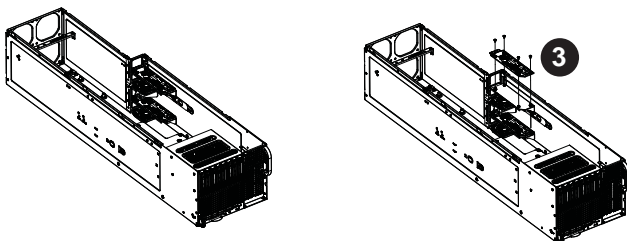

4. Remove the screw securing the upper power adapter bracket to the node and lift it out of the node.
5. Remove the screws securing the second power adapter board to the floor of the node and set the screws aside for later use.
6. Lift the second power adapter board up and out of the node.

Figure 6-14: Removing the Second Power Adapter Board

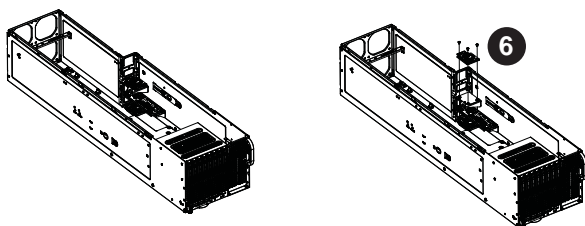

7. Remove the screw securing the second power adapter board bracket to the node, and remove the bracket from the node.
8. Remove the screws securing the third power adapter board to the bracket.
9. Lift the third power adapter board out of the node.

Figure 6-15: Removing the Third Power Adapter Board

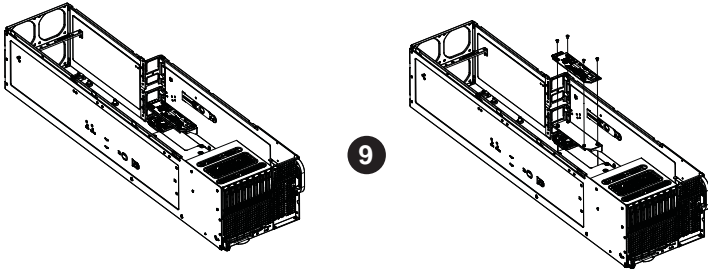

10. Remove the screw securing the third power adapter board bracket to the node. Lift the third power adapter bracket up and out of the node.
11. Remove the screws securing the lower power adapter board to the floor of the node. Lift the lower power adapter board up and out of the node.

Figure 6-16: Removing the Lower Power Adapter Board

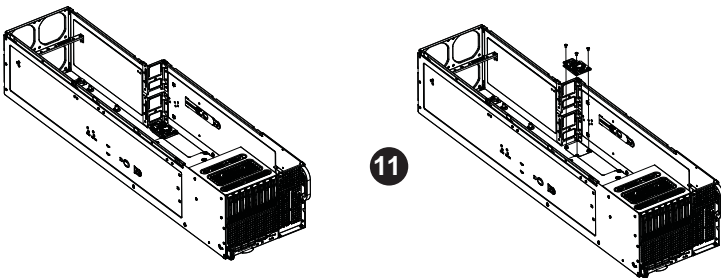

12. Install the replacement lower power adapter board into the same position on the floor of the serverboard node, aligning the mounting holes of the board with those in the node.

13. Secure the lower power adapter board to the floor of the node with the screws previously set aside. Do not exceed eight pounds of torque when tightening the screws.

Figure 6-17: Installing the Lower Power Adapter Board

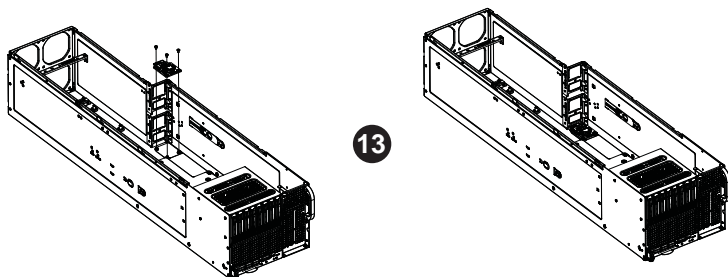

14. Put the third support bracket back into place in the node and secure it with the screw previously set aside.
15. Secure the third power adapter board to the support bracket using the screws previously set aside. Do not exceed eight pounds of torque when tightening the screws.

Figure 6-18: Replacing the Third Power Adapter Board

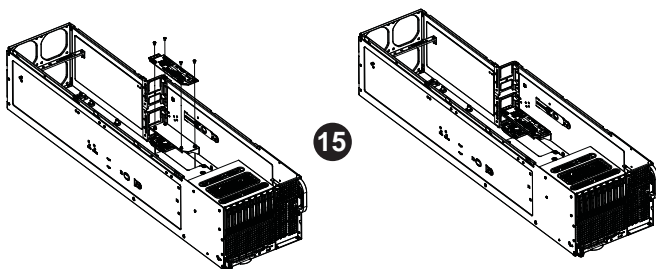

16. Put the second power adapter support bracket back into place in the node and secure it with the screw previously set aside.

- Secure the second power adapter board to the support bracket using the screws previously set aside. Do not exceed eight pounds of torque when tightening the screws.

Figure 6-19: Replacing the Second Power Adapter Board

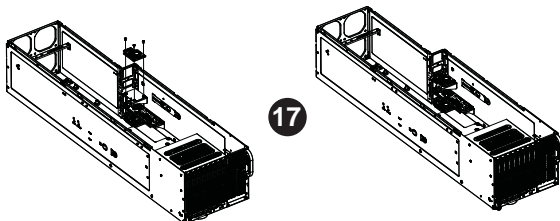

- Put the upper support bracket back into place in the node and secure it with the screw previously set aside.
- Secure the upper power adapter board to the support bracket using the screws previously set aside. Do not exceed eight pounds of torque when tightening the screws.

Figure 6-20: Replacing the Upper Power Adapter Board

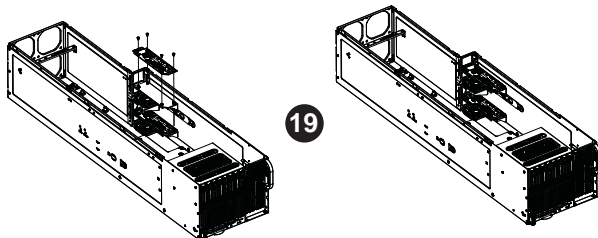

- Replace the air shroud and return the node to its bay in the chassis.
- Reattach the power cord to the back of the power supply and power up the node.

6-10 Installing the Serverboard

Compatible Motherboards

For the most up-to-date information on compatible motherboards and other parts, visit the Supermicro web site at www.supermicro.com.

Permanent and Optional Standoffs

Standoffs prevent short circuits by creating space between the serverboard and the floor of the node. The F442BG includes permanent standoffs in locations used by most motherboards. These standoffs use the rounded Phillips head screws included in the F442BG accessories packaging.

Some motherboards require additional screws for heatsinks, general components and/or non-standard security. Optional standoffs are used for these motherboards.

Remove the power cord from the rear of the node as described in Section 6-3. Remove the node from the chassis as described in Section 6-4. Place the node on a flat, stable surface and remove the node cover as described in Section 6-7.

To use an optional standoff, compare the mounting holes in the serverboard with those in the floor of the serverboard node. Then place a screw through the bottom the node and secure the screw with a hexagonal nut (rounded side up).

Depending upon the configuration of the serverboard being used, it is also possible that some of the optional standoffs which are pre-installed and may need to be removed. Add or remove standoffs as needed.

Figure 6-21: Installing the Serverboard in the Node

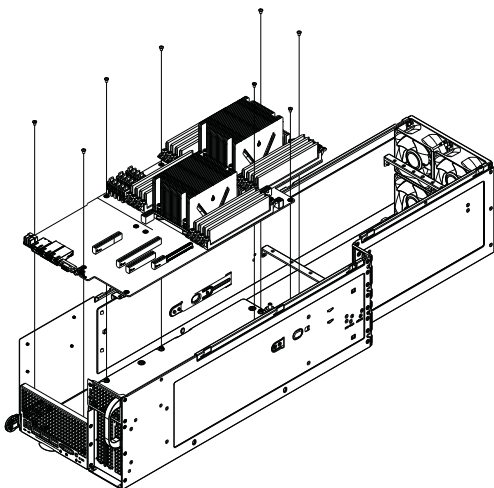

Installing the Serverboard

1. Review the documentation that came with your serverboard. Become familiar with component placement, requirements, cautions, and cable connections.
2. Remove the power cord from the rear of the node as described in Section 6-3. Remove the node from the chassis as described in Section 6-4. Place the node on a flat, stable surface and remove the node cover as described in Section 6-7.
3. Removed the HDD cage and GPU brackets from the MB tray.
4. Compare the holes in the serverboard to those in the node and add or remove standoffs as needed.
5. Lay the serverboard in the node and secure it to the floor of the node using the rounded, Phillips head screws included for this purpose. Do not exceed eight pounds of torque when tightening down the serverboard.
6. Secure the CPU(s), heatsinks, and other components to the serverboard as described in the serverboard documentation.
7. See the following page for instructions on installing expansion cards before connecting the reconnecting the cables.
8. Install the HDD cage and GPU bracket back into the serverboard tray.
9. After installing the expansion card, connect the cables between the serverboard, backplane, chassis, front panel, and power supply.
10. Place the air shroud as described in Section 6-13 Installing the Air Shroud
11. Return the node to the chassis.

6-11 Installing Front and Rear Expansion Cards

PCI-E Slot Setup

The nodes of the F442BG chassis models support full-height, half-length expansion cards. To install expansion cards, follow the instructions on the following pages.

Figure 6-22: PCI-E Slot Cover Configuration

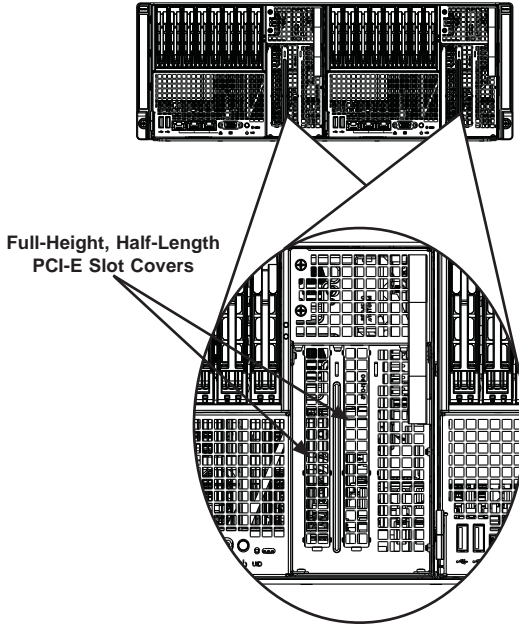

Installing an Expansion Card

Each serverboard node supports two full-height, half-length expansion cards.

Installing an Expansion Card into a Node

1. Remove the power cord from the rear of the node as described in Section 6-3. Remove the node from the chassis as described in Section 6-4. Place the node on a flat, stable surface and remove the node cover as described in Section 6-7.
2. Remove the mounting screw which secures the PCI-E slot cover in the PCI-E slot and set this aside for later use.
3. Remove the PCI-E slot cover by sliding it upward and out of the PCI-E slot.
4. Simultaneously slide the expansion card into the open PCI-E slot, while inserting the expansion card into the serverboard.
5. Secure the expansion card to the node using the screws that were previously set aside.
6. Replace the air shroud as described in the following section.
7. Place the cover on the node and secure it with the screws previously set aside.
8. Return the node to its bay in the chassis.

Figure 6-23: Installing the Expansion Card

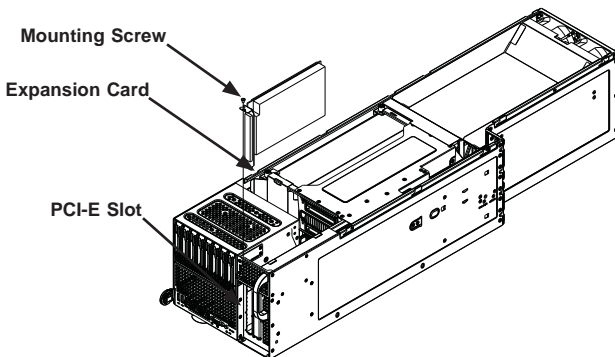

6-12 Installing Internal GPUs

Each node supports six internal GPUs. There are a variety of internal GPUs supported by the F442BG chassis. For the most up-to-date list of compatible GPUs, visit the Supermicro web site at www.supermicro.com.

Installing Front GPUs into the GPU Bracket

Installing a Front GPU into a Bracket

1. Remove the power cord from the rear of the node as described in Section 6-3. Remove the node from the chassis as described in Section 6-4. Place the node on a flat, stable surface and remove the node cover as described in Section 6-7.
2. Determine the correct method of installation for your particular GPU by examining the illustrations on the following pages. Follow steps three, four and five in the illustration specific to your GPU model on the following pages..

Figure 6-24: Installing the Front GPU into the Bracket

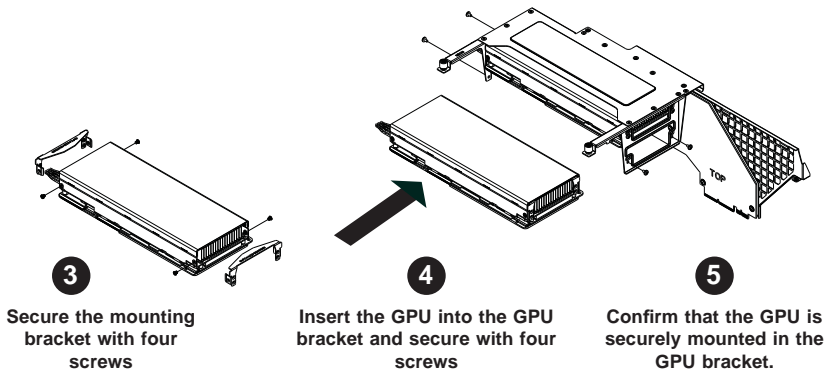

Installing a Front GPU into the Node

Installing a Front GPU into a Node

1. Confirm that the GPU has been correctly installed in the GPU bracket as described in the previous section.
2. Position the GPU bracket in the node as illustrated below.
3. Secure the GPU bracket to the node as shown using the three screws provided.
4. Proceed to the next section to install the rear internal GPUs.

Figure 6-25: Installing the Front Internal GPU into the Node

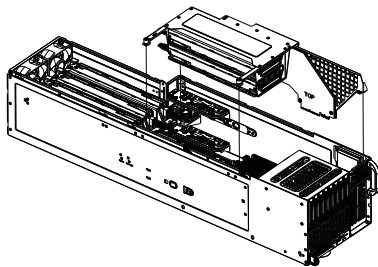

Preparation Before Installing Rear GPUs into the Node

Installing a Rear GPU into a Node

1. Confirm that the front GPU has been correctly installed as described in the previous section.
2. Place the GPU into the bracket as illustrated below.
3. Secure the GPU to the bracket using three screws.

Figure 6-26: Preparation Before Installing Rear GPUs into the Node

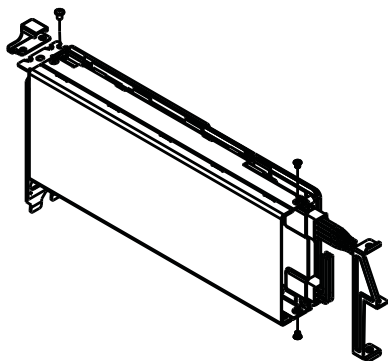

Installing the Rear 10.5" GPU into the Node

Installing a Rear GPU into a Node

1. Confirm that the GPU has been correctly installed in the GPU bracket as described in the previous section.
2. Position the GPU bracket in the node as illustrated below.
3. Secure the GPU bracket to the node as shown using the two screws provided.
4. Return the node to the chassis, reconnect the cord to the power supply and power up the system.

Figure 6-27: Installing the Rear 13" GPU into the Node

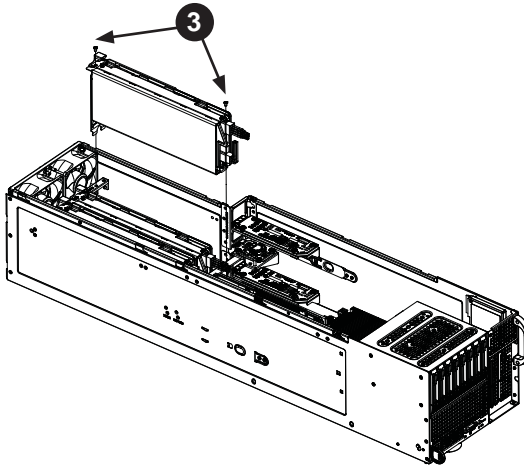

6-13 Installing the Air Shrouds

Air Shrouds

Air shrouds concentrate airflow to maximize fan efficiency. The F442BG chassis requires a front and rear air shroud in each serverboard node.

Installing the Air Shrouds

1. Remove the power cord from the rear of the node as described in Section 6-3. Remove the node from the chassis as described in Section 6-4. Place the node on a flat, stable surface and remove the node cover as described in Section 6-7.
2. Make sure that the serverboard and all components are properly installed in each serverboard node.
3. Place front and rear air shrouds over the serverboard, as illustrated above.
4. Repeat the procedure for the remaining serverboard node.

Figure 6-28: Installing the Air Shrouds

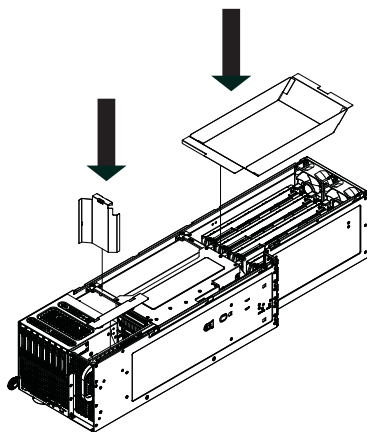

6-14 Checking the Airflow

Checking Airflow

1. Make sure there are no objects to obstruct airflow in and out of the server. In addition, if you are using a front bezel, make sure the bezel's filter is replaced periodically.
2. Do not operate the server without drive carriers and either a drive or dummy drive in the carrier. Use only recommended server parts.
3. Make sure no wires or foreign objects obstruct airflow through the chassis. Pull all excess cabling out of the airflow path or use shorter cables.

Installation Complete

In most cases, the node power supplies and fans are pre-installed. If you need to install fans or power supplies, continue to the Systems Fan and Power Supply sections of this chapter. If the chassis will be installed into a rack, continue to the next chapter for rack installation instructions.

6-15 Replacing Exhaust Fans

Each node supports rear exhaust fans that provide cooling for the node. These fans circulate air through the node as a means of lowering the internal temperature. In the unlikely event of a fan failure, the F442BG fans are easily removed from the rear of the node without tools.

These fans are redundant, but NOT hot-plug and should be replaced when they fail.

Removing a Rear Exhaust Fan

1. Determine which node contains the failed fan and power down the node with the operating system.
2. Remove the power cord from the rear of the node as described Section 6-3.
3. Press the release tab on the bottom of the fan and pull it away from rear of the node.

Installing a Rear Exhaust Fan

4. Press the release tab on the bottom of the fan and insert it into the open fan bay.
5. Push the fan into the bay until it clicks into the locked position.

Figure 6-29: Replacing a Rear Fan

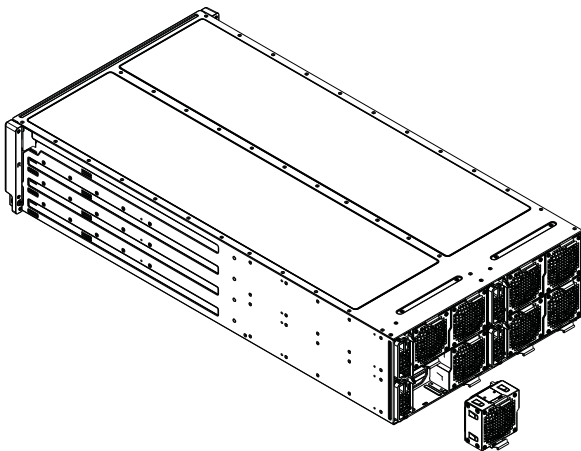

6-16 Replacing the Power Supply

The F442BG chassis includes a 2000 Watt power supply. This power supply is auto-switching capable. This enables it to automatically sense and operate at a 100v to 240v input voltage. An amber light will be illuminated on the power supply when the power is off. An illuminated green light indicates that the power supply is operating.

Power Supply Replacement

The F442BG chassis utilizes redundant, hot-plug power supplies, with a total of four power supplies in the chassis. In the unlikely event that the power supply unit needs to be replaced, one power supply can be removed, without powering down the system. Replacement units can be ordered directly from Supermicro (See the contact information in the Preface of this manual).

Changing the Power Supply

1. Disconnect the power cord on the back of the failed power supply as described in Section 6-3.
2. Press the release tab on the back of the power supply and pull the power supply out using the handle provided.
3. Push the replacement power supply module into the power bay until it clicks into the locked position.
4. Plug the AC power cord back into the module and return the node to its bay in the chassis.

Figure 6-30: Changing the Power Supply

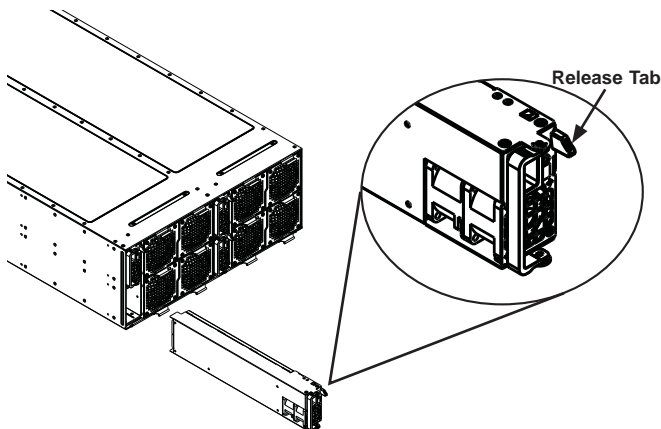

Chapter 7

BIOS

7-1 Introduction

This chapter describes the AMI BIOS Setup utility for the X10DRFF-CG/CTG. It also provides the instructions on how to navigate the AMI BIOS Setup utility screens. The AMI ROM BIOS is stored in a Flash EEPROM and can be easily updated.

Starting BIOS Setup Utility

To enter the AMI BIOS Setup utility screens, press the key while the system is booting up.

Note: In most cases, the key is used to invoke the AMI BIOS setup screen. There are a few cases when other keys are used, such as <F3>, <F4>, etc.

Each main BIOS menu option is described in this manual. The Main BIOS setup menu screen has two main frames. The left frame displays all the options that can be configured. Grayed-out options cannot be configured. Options in blue can be configured by the user. The right frame displays the key legend. Above the key legend is an area reserved for informational text related to the option currently selected in the left frame. When an option is selected in the left frame, it is highlighted in white.

Note: The AMI BIOS has default informational messages built in. The manufacturer retains the option to include, omit, or change any of these messages.

The AMI BIOS Setup utility uses a key-based navigation system called "hot keys." Most of the AMI BIOS setup utility "hot keys" can be used at any time during setup navigation. These keys include <F3>, <F4>, <Enter>, <ESC>, arrow keys, etc.

Note 1: Options printed in **Bold** are default settings.

Note 2: <F3> is used to load optimal default settings. <F4> is used to save the settings and exit the setup utility.

How To Change the Configuration Data

The configuration data that determines the system parameters may be changed by entering the AMI BIOS Setup utility. This Setup utility can be accessed by pressing <Delete> at the appropriate time during system boot.

Note: For AMI UEFI BIOS Recovery, please refer to the UEFI BIOS Recovery User Guide posted @<http://www.supermicro.com/support/manuals/>.

Starting the Setup Utility

Normally, the only visible Power-On Self-Test (POST) routine is the memory test. As the memory is being tested, press the <Delete> key to enter the main menu of the AMI BIOS Setup utility. From the main menu, you can access the other setup screens. An AMI BIOS identification string is displayed at the left bottom corner of the screen below the copyright message.

Warning! Do not upgrade the BIOS unless your system has a BIOS-related issue. Flashing the wrong BIOS can cause irreparable damage to the system. In no event shall the manufacturer be liable for direct, indirect, special, incidental, or consequential damage arising from a BIOS update. If you have to update the BIOS, do not shut down or reset the system while the BIOS is being updated to avoid possible boot failure.

7-2 Main Setup

When you first enter the AMI BIOS setup utility, you will enter the Main setup screen. You can always return to the Main setup screen by selecting the Main tab on the top of the screen. The Main BIOS setup screen is shown below.

The following Main menu items will be displayed:



System Date/System Time

Use this option to change the system date and time. Highlight *System Date* or *System Time* using the arrow keys. Enter new values using the keyboard. Press the <Tab> key or the arrow keys to move between fields. The date must be entered in Day MM/DD/YYYY format. The time is entered in HH:MM:SS format.

Note: The time is in the 24-hour format. For example, 5:30 P.M. appears as 17:30:00.

Supermicro X10DRFF-iG/CG

Version: This item displays the version of the BIOS ROM used in the system.

Build Date: This item displays the date when the version of the BIOS ROM used in the system was built.

Memory Information

Total Memory: This item displays the total size of memory available in the system.

Memory Speed: This item displays the default speed of the memory modules installed in the system.

7-3 Advanced Setup Configurations

Use the arrow keys to select Advanced setup and press <Enter> to access the submenu items:

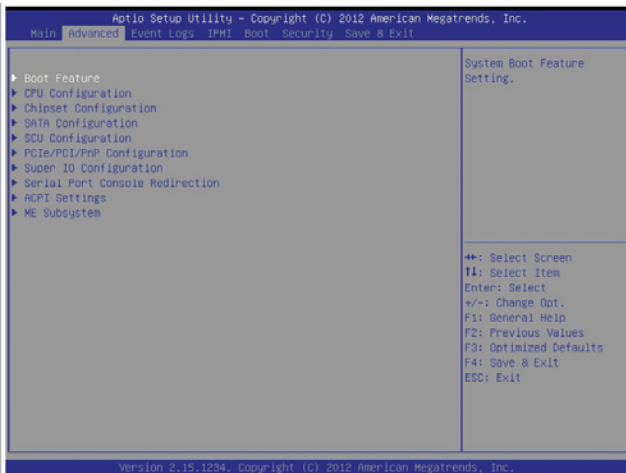

Warning: Take Caution when changing the Advanced settings. An incorrect value, a very high DRAM frequency or an incorrect BIOS timing setting may cause the system to malfunction. When this occurs, restore the setting to the manufacture default setting.

► Boot Feature

Quiet Boot

Use this feature to select the screen display between POST messages or the OEM logo at bootup. Select Disabled to display the POST messages. Select Enabled to display the OEM logo instead of the normal POST messages. The options are **Enabled** and Disabled.

AddOn ROM Display Mode

Use this item to set the display mode for the Option ROM. Select Keep Current to use the current AddOn ROM display setting. Select Force BIOS to use the Option ROM display mode set by the system BIOS. The options are **Force BIOS** and Keep Current.

Bootup Num-Lock State

Use this item to set the Power-on state for the Numlock key. The options are Off and **On**.

Wait For 'F1' If Error

Select Enabled to force the system to wait until the <F1> key is pressed if an error occurs. The options are Disabled and **Enabled**.

Interrupt 19 Capture

Interrupt 19 is the software interrupt that handles the boot disk function. When this item is set to Immediate, the ROM BIOS of the host adaptors will "capture" Interrupt 19 at bootup immediately and allow the drives that are attached to the host adaptors to function as bootable disks. If this item is set to Postponed, the ROM BIOS of the host adaptors will not capture Interrupt 19 immediately to allow the drives attached to the adaptors to function as bootable devices at bootup. The options are **Immediate** and Postponed.

Re-try Boot

Select EFI Boot to allow the BIOS to automatically reboot the system from an EFI boot device after its initial boot failure. Select Legacy Boot to allow the BIOS to automatically reboot the system from a Legacy boot device after its initial boot failure. The options are **Disabled**, Legacy Boot, and EFI Boot.

Power Configuration

Watch Dog Function

Select Enabled to allow the Watch Dog timer to reboot the system when it is inactive for more than 5 minutes. The options are Enabled and **Disabled**.

Power Button Function

This feature controls how the system shuts down when the power button is pressed. Select 4 Seconds Override for the user to power off the system after pressing and holding the power button for 4 seconds or longer. Select Instant Off to instantly power off the system as soon as the user presses the power button. The options are 4 Seconds Override and **Instant Off**.

Restore on AC Power Loss

Use this feature to set the power state after a power outage. Select Power Off for the system power to remain off after a power loss. Select Power On for the system power to be turned on after a power loss. Select Last State to allow the system to resume its last power state before a power loss. The options are Power On, Stay Off, and **Last State**.

► CPU Configuration

This submenu displays the following CPU information as detected by the BIOS. It also allows the user to configure CPU settings.

- Processor Socket
- Processor ID
- Processor Frequency
- Processor Max Ratio
- Processor Min Ratio
- Microcode Revision
- L1 Cache RAM
- L2 Cache RAM
- L3 Cache RAM
- CPU 1 Version
- CPU 2 Version

Clock Spread Spectrum

Select Enabled to allow the BIOS to monitor and attempt to reduce the level of Electromagnetic Interference caused by the components whenever needed. The options are **Disabled** and Enabled.

Hyper-Threading (All)

Select Enable to support Intel's Hyper-threading Technology to enhance CPU performance. The options are **Enable** and Disable.

Cores Enabled

This feature allows the user to determine the number of CPU cores to enable. Enter "0" to enable all cores. The default setting is **0**, which enables all CPU cores in the system.

Execute Disable Bit (Available if supported by the OS & the CPU)

Select Enable for Execute Disable Bit Technology support, which will allow the processor to designate areas in the system memory where an application code can execute and where it cannot, thus preventing a worm or a virus from flooding illegal codes to overwhelm the processor to damage the system during an attack. The options are **Enable** and Disable. (Refer to Intel's and Microsoft's websites for more information.)

PPIN Control

Select Unlock/Enable to use the Protected-Processor Inventory Number (PPIN) control in the system. The options are **Unlock/Enable** and Unlock/Disable.

Hardware Prefetcher (Available when supported by the CPU)

If set to Enable, the hardware prefetcher will prefetch streams of data and instructions from the main memory to the L2 cache to improve CPU performance. The options are Disable and **Enable**.

Adjacent Cache Prefetch (Available when supported by the CPU)

Select Enable for the CPU to prefetch both cache lines for 128 bytes as comprised. Select Disable for the CPU to prefetch both cache lines for 64 bytes. The options are Disable and **Enable**.

Note: Please reboot the system for changes on this setting to take effect. Please refer to Intel's website for detailed information.

DCU (Data Cache Unit) Streamer Prefetcher (Available when supported by the CPU)

If set to Enable, the DCU Streamer prefetcher will prefetch data streams from the cache memory to the DCU (Data Cache Unit) to speed up data accessing and processing to enhance CPU performance. The options are Disable and **Enable**.

DCU IP Prefetcher

If set to Enable, the IP prefetcher in the DCU (Data Cache Unit) will prefetch IP addresses to improve network connectivity and system performance. The options are **Enable** and Disable.

Direct Cache Access (DCA)

Select Enable to use Intel DCA (Direct Cache Access) Technology to improve the efficiency of data transferring and accessing. The options are **Auto**, Enable, and Disable.

X2 APIC (Advanced Programmable Interrupt Controller)

Based on Intel's Hyper-Threading architecture, each logical processor (thread) is assigned 256 APIC IDs (APIDs) in 8-bit bandwidth. When this feature is set to Enable, the APIC ID will expand(X2) from 8 bits to 16 bits to provide 512 APIDs to each thread for CPU performance enhancement. The options are **Disable** and Enable.

AES-NI

Select Enable to use the Intel Advanced Encryption Standard (AES) New Instructions (NI) to ensure data security. The options are **Enable** and Disable.

Intel Virtualization Technology

Select Enable to use Intel Virtualization Technology support for Direct I/O VT-d support by reporting the I/O device assignments to the VMM (Virtual Machine Monitor) through the DMAR ACPI tables. This feature offers fully-protected I/O resource sharing across Intel platforms, providing greater reliability, security and availability in networking and data-sharing. The options are **Enable** and Disable.

► Advanced Power Management Configuration

Advanced Power Management Configuration

Power Technology

Select Energy Efficient to support power-saving mode. Select Custom to customize system power settings. Select Disabled to disable power-saving settings. The options are Disable, **Energy Efficient**, and Custom.

► CPU P State Control (Available when Power Technology is set to Custom)

EIST (P-States)

EIST (Enhanced Intel SpeedStep Technology) allows the system to automatically adjust the processor voltage and core frequency to reduce power consumption and heat dissipation. The options are Disable and **Enable**.

Turbo Mode

Select Enabled to use the Turbo Mode to boost system performance. The options are **Enable** and Disable.

P-State Coordination

This feature is used to change the P-state (Power-Performance State) coordination type. P-state is also known as "SpeedStep" for Intel processors. Select HW_ALL to change the P-state coordination type for hardware components only. Select SW_ALL to change the P-state coordination type for all software installed in the system. Select SW_ANY to change the P-state coordination type for a software program in the system. The options are **HW_All**, SW_ALL, and SW_ANY.

► CPU C State Control (Available when Power Technology is set to Custom)

Package C State limit

Use this item to set the limit on the C-State package register. The options are C0/1 state, C2 state, C6 (non-Retention) state, **C6 (Retention) state**, and No Limit.

CPU C3 Report

Select Enable to allow the BIOS to report the CPU C3 State (ACPI C2) to the operating system. During the CPU C3 State, the CPU clock generator is turned off. The options are Enable and **Disable**.

CPU C6 Report (Available when Power Technology is set to Custom)

Select Enable to allow the BIOS to report the CPU C6 state (ACPI C3) to the operating system. During the CPU C6 state, power to all cache is turned off. The options are **Enable** and Disable.

Enhanced Halt State (C1E)

Select Enabled to use Enhanced Halt-State technology, which will significantly reduce CPU power consumption by reducing CPU clock cycles and voltages during a Halt-state. The options are Disable and **Enable**.

► CPU T State Control (Available when Power Technology is set to Custom)

ACPI (Advanced Configuration Power Interface) T-States

Select Enable to support CPU throttling by the operating system to reduce power consumption. The options are **Enable** and Disable.

► Socket RAPL (Running Average Power Limit) Config. (Configuration)

FAST_RAPL_NSTRIKE_PL2_DUTY_CYCLE

This feature displays the value of the item above within the range between 25 (10%) and 64 (25%). The default setting is **64**.

Turbo Power Limit Lock

Select Enable to set the power use limit for the machine when it is running in the turbo mode. The options are Enable and **Disable**.

Long Pwr (Power) Limit Ovr (Override)

Select Enable to support long-term power limit override. If this feature is disabled, BIOS will set the default value. The options are **Enable** and Disable.

Long Dur (Duration) Power Limit

This item displays the power limit set by the user during which long duration power is maintained. The default setting is **0**.

Long Dur (Duration) Time Window

Use this item to set the time window value (in seconds) over which the TDP (Thermal Design Point) should be maintained. The default setting is **1**, which will allow the value to be automatically programmed by the system.

Pkg (Package) Clmp (Clamping) Limit1

Use this item to set the limit on power performance states for the runtime processor, with P0 being the state with the highest frequency (clock speed) and power (consumption), and P1, a step lower in performance than P0, with its frequency and voltage scaled back a notch. The options are Between P1/P0 and **Below P1**.

Short Dur (Duration) Pwr (Power) Limit En (Enable)

Select Enable to support Short Duration Power Limit (Power Limit 2). The options are **Enable** and Disable.

Short Dur (Duration) Pwr (Power) Limit

This item displays the time period during which short duration power is maintained. The default setting is **0**.

Pkg (Package) Clmp (Clamping) Lim2

Use this item to set the limit on power performance states for the processor operating in turbo mode, with P0 being the state with the highest frequency (clock speed) and power (consumption), and P1, a step lower in performance than P0, with its frequency and voltage scaled back a notch. The options are Between P1/P0 and **Below P1**.

► DRAM RAPL (Running Average Power Limit) Configuration**DRAM RAPL (Running Average Power Limit) Baseline**

Use this item to set the run-time power-limit baseline for DRAM modules. The options are Disable, DRAM RAPL Mode 0, and **DRAM RAPL Mode 1**.

Override BW_LIMIT_TF (BW_limit_tf)

This feature allows the user to turn off the "Override BW_Limit_TF (Time Frame)" setting when the item--the "Running Average Power Limit for DRAM modules" (DRAM RAPL) is set to Enabled so that the DRAM RAPL setting can work properly. The default setting is **1**.

DRAM RAPL (Running Average Power Limit) Extended Range

Select Enable to extend the RAPL range for the DRAM modules. The options are Disable and **Enable**.

► Chipset Configuration

Warning! Please set the correct settings for the items below. A wrong configuration setting may cause the system to become malfunction.

► North Bridge

This feature allows the user to configure the settings for the Intel North Bridge.

► IIO Configuration

EV DFX (Device Function On-Hide) Features

When this feature is set to Enable, the EV_DFX Lock Bits that are located on a processor will always remain clear during electric tuning. The options are **Disable** and Enable.

► IIO0 Configuration

IOU2 (IIO PCIe Port 1)

This item configures the PCI-E port Bifuraction setting for a PCI-E port specified by the user. The options are x4x4, **x8**, and Auto.

IOU0 (IIO PCIe Port 2)

This item configures the PCI-E port Bifuraction setting for a PCI-E port specified by the user. The options are x4x4x4x4, x4x4x8, x8x4x4, **x8x8**, x16, and Auto.

IOU1 (IIO1 PCIe Port 3)

This item configures the PCI-E port Bifuraction setting for a PCI-E port specified by the user. The options are x4x4x4x4, x4x4x8, x8x4x4, **x8x8**, x16, and Auto..

No PCIe Port Active ECO (Engineer Change Order)

This feature provides a work-around solution when there is no active PCI device detected by the BIOS. The options are **PCU Squelch Exit Ignore Option** and Reset the SQ FLOP by CSR Option.

► Socket 0 PCIeD00F0 - Port 0/DMI**Link Speed**

This item configures the link speed of a PCI-E port specified by the user. The options are Gen 1 (Generation 1) (2.5 GT/s), Gen 2 (Generation 2) (5 GT/s), and **Auto**.

PCI-E Port DeEmphasis

This item configures the De-Emphasis Control (LANKCON2 [6]) setting for this computer. The options are **-6.0 dB** and -3.5 dB.

The following items will be display:

- PCI-E Port Link Status
- PCI-E Port Link Max
- PCI-E Port Link Speed

PCI-E Port L0s Exit Latency

Use this item to set the length of time required for the port specified by the user to complete the transition from L0s to L0. The default setting is **4uS - 8uS**.

PCI-E Port L1 Exit Latency

Use this item to set the length of time required for the port specified by the user to complete the transition from L1 to L0. The default setting is <1uS, 1uS - 2uS, 2uS - 4uS, 4uS - 8uS, **8uS - 16uS**, 16uS - 32uS, 32uS - 64uS, and >64uS.

Fatal Err (Error) Over

Select Enable to force fatal error prorogation to the IIO core error logic for the port specified by the user. The options are **Disable** and Enable.

Non-Fatal Err (Error) Over

Select Enable to force non-fatal error prorogation to the IIO core error logic for the port specified by the user. The options are **Disable** and Enable.

Corr Err (Correctable Error) Over

Select Enable to force correctable error prorogation to the IIIIO core error logic for the port specified by the user. The options are **Disable** and Enable.

L0s Support

When this item is set to Disable, IIO will not put its transmitter in the L0s state. The default setting is **Disable**.

► **Socket 0 PCIeD01F0 - Port 1A/Socket 0 PCIeD02F0 - Port 2A/
Socket 0 PCIeD20F2 - Port 2C/Socket 0 PCIeD03F0 - Port 3A/Socket
0 PCIeD03F2 - Port 3C**

PCI-E Port

Select Enable to enable the PCI-E port specified by the user. The options are **Auto**, Enable, and Disable.

Hot Plug Capable

Select Enable to enable hot-plugging support for the PCI-E port specified by the user to allow the user to replace the device installed on the port without shutting down the system. The options are **Disable** and Enable.

PCI-E Port Link

Select Disable to disable the link that is not involved in training activities, but its CFG is still active. The options are **Enable** and Disable.

Link Speed

Use this item to select the link speed for the PCI-E port specified by the user. The options are GEN1 (2.5 GT/s), GEN2 (5 GT/s), GEN3 (8 GT/s), and **Auto**.

PCI-E Port DeEmphasis

Use this item to select the De-Emphasis control setting for a PCI-E port specified by the user. The options are **-6.0 dB** and -3.5 dB.

The following items will be display:

- PCI-E Port Link Status
- PCI-E Port Link Max
- PCI-E Port Link Speed

PCI-E Port L0s Exit Latency

Use this item to set the length of time required for the port specified by the user to complete the transition from L0s to L0. The default setting is **4uS - 8uS**.

PCI-E Port L1 Exit Latency

Use this item to set the length of time required for the port specified by the user to complete the transition from L1 to L0. The default setting is <1uS, 1uS - 2uS, 2uS - 4uS, 4uS - 8uS, **8uS - 16uS**, 16uS - 32uS, 32uS - 64uS, and >64uS.

Fatal Err (Error) Over

Select Enable to force fatal error prorogation to the IIO core error logic for the port specified by the user. The options are **Disable** and Enable.

Non-Fatal Err (Error) Over

Select Enable to force non-fatal error prorogation to the IIO core error logic for the port specified by the user. The options are **Disable** and Enable.

Corr Err (Correctable Error) Over

Select Enable to force correctable error prorogation to the IIIO core error logic for the port specified by the user. The options are **Disable** and Enable.

L0s Support

When this item is set to Disable, IIO will not put its transmitter in the L0s state. The default setting is **Disable**.

PM ACPI Support

Select Enable to generate an _HPGPE message on a PM ACPI event. Select Disable to generate an MSI message. The options are **Disable** and Enable.

Gen3 (Generation 3) Eq (Equalization) Mode

Use this item to set the "Adaptive Equalization" mode for PCI-E Generation 3 devices. The options are **Auto**, Enable Phase 0, 1, 2, 3; Disable Phase 0, 1, 2, 3; Enable Phase 1 Only, Enable Phase 0, 1 Only, Enable MMM Offset West, and Advanced.

Gen3 (Generation 3) Spec (Specifics) Mode

Use this item to set the Specifics mode for PCI-E Generation 3 devices. The options are **Auto**, 0.70 July, 0.70 Sept and 071 Sept.

Gen3 (Generation 3) Phase2 Mode

Use this item to set the PCI-E Generation 3 Phase 2 mode. The options are **Hardware Adaptive** and Manual.

Gen3 (Generation 3) DN TX Preset

Use this item to set the Preset mode for PCI-E Gen3 downstream transmitting (TX) from the master device to a slave device. The options are **Auto**, P0 (-6.0/0.0 dB), P1 (-3.5/0.0 dB), P2 (-4.5/0.0 dB), P3 (-2.5/0.0 dB), P4 (0.0/0.0 dB), P5 (0.0/2.0 dB), P6 (0.0/2.5 dB), P7 (-6.0 /3.5 dB), P8 (-3.5/3.5 dB), and P9 (0.0/3.5 dB).

Gen3 (Generation 3) DN RX Preset Hint

Use this item to set the Preset Hint mode for PCI-E Gen3 downstream receiving (RX) from the master device to a slave device. The options are **Auto**, P0 (-6.0 dB), P1 (-7.0 dB), P2 (-8.0 dB), P3 (-9.0 dB), P4 (-10.0 dB) P5 (-11.0 dB), and P6 (-12.0 dB).

Gen3 (Generation 3) Up TX Preset

Use this item to set the Preset mode for PCI-E Gen3 upstream transmitting (TX) from a slave device to the master device. The options are **Auto**, P0 (-6.0/0.0 dB), P1 (-3.5/0.0 dB), P2 (-4.5/0.0 dB), P3 (-2.5/0.0 dB), P4 (0.0/0.0 dB), P5 (0.0/2.0 dB), P6 (0.0/2.5 dB), P7 (-6.0/3.5 dB), P8 (-3.5/3.5 dB), and P9 (0.0/3.5 dB).

Non-Transparent Bridge PCIe Port Definition (Available on the Socket 0 PCIeD03F0 - Port 3A only)

Select Transparent Bridge to enable Transparent Bridge support for the PCI-E port specified by the user. Please do not select NTB-RP for a legacy IIO device. The options are **Transparent Bridge**, NTB to NTB, and NTB to RP.

Hide Port?

Select Yes to hide the PCI-E port specified from the OS. The options are **No** and Yes.

► IIO1 Configuration**IOU2 (IIO PCIe Port 1)**

This item configures the PCI-E port Bifurcation setting for a PCI-E port specified by the user. The options are x4x4, **x8**, and Auto.

IOU0 (IIO PCIe Port 2)

This item configures the PCI-E port Bifurcation setting for a PCI-E port specified by the user. The options are x4x4x4x4, x4x4x8, x8x4x4, **x8x8**, x16, and Auto.

IOU1 (IIO1 PCIe Port 3)

This item configures the PCI-E port Bifurcation setting for a PCI-E port specified by the user. The options are x4x4x4x4, x4x4x8, x8x4x4, x8x8, **x16**, and Auto..

No PCIe Port Active ECO (Engineer Change Order)

This feature provides a work-around solution when there is no active PCI device detected by the BIOS. The options are **PCU Squelch Exit Ignore Option** and Reset the SQ FLOP by CSR Option..

► **Socket 1 PCIeD00F0 - Port 0/DMI/Socket 1 PCIeD01F0 - Port 1A/Socket 1 PCIeD02F0 - Port 2A/Socket 1 PCIeD20F2 - Port 2C/Socket 1 PCIeD03F0 - Port 3A**

PCI-E Port

Select Enable to enable the PCI-E port specified by the user. The options are **Auto**, Enable, and Disable.

Hot Plug Capable

Select Enable to enable hot-plugging support for the PCI-E port specified by the user to allow the user to replace the device installed on the port without shutting down the system. The options are **Disable** and Enable.

PCI-E Port Link

Select Disable to disable the link that is not involved in training activities, but its CFG is still active. The options are **Enable** and Disable.

Link Speed

Use this item to select the link speed for the PCI-E port specified by the user. The options are GEN1 (2.5 GT/s), GEN2 (5 GT/s), GEN3 (8 GT/s), and **Auto**.

PCI-E Port DeEmphasis

Use this item to select the De-Emphasis control setting for a PCI-E port specified by the user. The options are **-6.0 dB** and -3.5 dB.

The following items will be display:

- PCI-E Port Link Status
- PCI-E Port Link Max
- PCI-E Port Link Speed

PCI-E Port L0s Exit Latency

Use this item to set the length of time required for the port specified by the user to complete the transition from L0s to L0. The default setting is **4uS - 8uS**.

PCI-E Port L1 Exit Latency

Use this item to set the length of time required for the port specified by the user to complete the transition from L1 to L0. The default setting is <1uS, 1uS - 2uS, 2uS - 4uS, 4uS - 8uS, **8uS - 16uS**, 16uS - 32uS, 32uS - 64uS, and >64uS.

Fatal Err (Error) Over

Select Enable to force fatal error prorogation to the IIO core error logic for the port specified by the user. The options are **Disable** and Enable.

Non-Fatal Err (Error) Over

Select Enable to force non-fatal error prorogation to the IIO core error logic for the port specified by the user. The options are **Disable** and Enable.

Corr Err (Correctable Error) Over

Select Enable to force correctable error prorogation to the IIO core error logic for the port specified by the user. The options are **Disable** and Enable.

L0s Support

When this item is set to Disable, IIO will not put its transmitter in the L0s state. The default setting is **Disable**.

PM ACPI Support

Select Enable to generate an _HPGPE message on a PM ACPI event. Select Disable to generate an MSI message. The options are **Disable** and Enable.

Gen3 (Generation 3) Eq (Equalization) Mode

Use this item to set the "Adaptive Equalization" mode for PCI-E Generation 3 devices. The options are **Auto**, Enable Phase 0, 1, 2, 3; Disable Phase 0, 1, 2, 3; Enable Phase 1 Only, Enable Phase 0, 1 Only, Enable MMM Offset West, and Advanced.

Gen3 (Generation 3) Spec (Specifics) Mode

Use this item to set the Specifics mode for PCI-E Generation 3 devices. The options are **Auto**, 0.70 July, 0.70 Sept and 071 Sept.

Gen3 (Generation 3) Phase2 Mode

Use this item to set the PCI-E Generation 3 Phase 2 mode. The options are **Hardware Adaptive** and Manual.

Gen3 (Generation 3) DN TX Preset

Use this item to set the Preset mode for PCI-E Gen3 downstream transmitting (TX) from the master device to a slave device. The options are **Auto**, P0 (-6.0/0.0 dB), P1 (-3.5/0.0 dB), P2 (-4.5/0.0 dB), P3 (-2.5/0.0 dB), P4 (0.0/0.0 dB), P5 (0.0/2.0 dB), P6 (0.0/2.5 dB), P7 (-6.0 /3.5 dB), P8 (-3.5/3.5 dB), and P9 (0.0/3.5 dB).

Gen3 (Generation 3) DN RX Preset Hint

Use this item to set the Preset Hint mode for PCI-E Gen3 downstream receiving (RX) from the master device to a slave device. The options are **Auto**, P0 (-6.0 dB), P1 (-7.0 dB), P2 (-8.0 dB), P3 (-9.0 dB), P4 (-10.0 dB), P5 (-11.0 dB), and P6 (-12.0 dB).

Gen3 (Generation 3) Up TX Preset

Use this item to set the Preset mode for PCI-E Gen3 upstream transmitting (TX) from a slave device to the master device. The options are **Auto**, P0 (-6.0/0.0 dB), P1 (-3.5/0.0 dB), P2 (-4.5/0.0 dB), P3 (-2.5/0.0 dB), P4 (0.0/0.0 dB), P5 (0.0/2.0 dB), P6 (0.0/2.5 dB), P7 (-6.0/3.5 dB), P8 (-3.5/3.5 dB), and P9 (0.0/3.5 dB).

Non-Transparent Bridge PCIe Port Definition (Available on the Socket 1 PCIeD03F0 - Port 3A only)

Select Transparent Bridge to enable Transparent Bridge support for the PCI-E port specified by the user. Please do not select NTB-RP for a legacy IIO device. The options are **Transparent Bridge**, NTB to NTB, and NTB to RP.

Hide Port?

Select Yes to hide the PCI-E port specified from the OS. The options are **No** and Yes.

►IOAT (Intel® IO Acceleration) Configuration**Enable IOAT**

Select Enable to enable Intel I/OAT (I/O Acceleration Technology) support, which significantly reduces CPU overhead by leveraging CPU architectural improvements and freeing the system resource for other tasks. The options are **Enable** and Disable.

No Snoop

Select Enable to support no-snoop mode for each CB device. The options are **Disable** and Enable.

Relaxed Ordering

Select Enable to enable Relaxed Ordering support which will allow certain transactions to violate the strict-ordering rules of PCI bus for a transaction to be completed prior to other transactions that have already been enqueued. The options are **Disable** and Enable.

► Intel VT for Directed I/O (VT-d)

Intel® VT for Directed I/O (VT-d)

Select Enable to use Intel Virtualization Technology for Direct I/O VT-d support by reporting the I/O device assignments to the VMM (Virtual Machine Monitor) through the DMAR ACPI tables. This feature offers fully-protected I/O resource sharing across Intel platforms, providing greater reliability, security and availability in networking and data-sharing. The options are **Enable** and Disable.

Interrupt Remapping

Select Enable for Interrupt Remapping support to enhance system performance. The options are **Enable** and Disable.

► QPI (Quick Path Interconnect) Configuration

► QPI General Configuration

► QPI Status

The following information will display:

- Number of CPU
- Number of IIO
- Current QPI Link Speed
- Current QPI Link Frequency
- QPI Global MMIO Low Base/Limit
- QPI Global MMIO High Base/Limit
- QPI PCIe Configuration Base/Size

Link Frequency Select

Use this item to select the desired frequency for QPI Link connections. The options are 6.4GB/s, 8.0GB/s, 9.6GB/s, **Auto**, and Auto Limited.

Link L0p Enable

Select Enable for Link L0p support to reduce power consumption. The options are **Enable** and Disable.

Link L1 Enable

Select Enable for Link L1 support to reduce power consumption. The options are **Enable** and Disable.

COD Enable (Available when the OS and the CPU support this feature)

Select Enable for Cluster-On-Die support to enhance system performance in cloud computing. The options are Enable and **Disable**.

Early Snoop (Available when the OS and the CPU support this feature)

Select Enable for Early Snoop support to enhance system performance. The options are Enable, Disable, and **Auto**.

Isoc Mode

Select Enable for Isochronous support to meet QoS (Quality of Service) requirements. This feature is especially important for Intel Virtualization Technology. The options are Enable and **Disable**.

► Memory Configuration

This submenu allows the user to configure Integrated Memory Controller (IMC) settings.

Enforce POR

Select Enabled to enforce POR restrictions on DDR4 frequency and voltage programming. The options are **Enabled** and Disabled.

Memory Frequency

Use this feature to set the maximum memory frequency for onboard memory modules. The options are **Auto**, 1333, 1400, 1600, 1800, 1867, 2000, 2133, 2200, 2400, 2600, 2667, 2800, 2993, 3000, 3200, and Reserved (Do not select Reserved).

Data Scrambling

Select Enabled to enable data scrambling to enhance system performance and data integrity. The options are **Auto**, Disabled and Enabled.

DRAM RAPL (Running Average Power Limit) Baseline

Use this feature to set the run-time power-limit baseline for DRAM modules. The options are Disable, DRAM RAPL Mode 0, and **DRAM RAPL Mode 1**.

Set Throttling Mode

Throttling improves CPU reliability and reduces power consumption via automatic-voltage control during CPU idle states. The options are Disabled and **CLTT** (Closed Loop Thermal Throttling).

Socket Interleave Below 4GB

Select Enable for the memory above the 4G Address space to be split between two sockets. The options are Enable and **Disable**.

A7 Mode

Select Enable to support the A7 (Addressing) mode to improve memory performance. The options are **Enable** and Disable.

► DIMM Information

This item displays the status of a DIMM module as detected by the AMI BIOS.

- P1 DIMMA1
- P2 DIMME1

► Memory RAS (Reliability_Availability_Serviceability) Configuration

Use this submenu to configure the following Memory RAS settings.

RAS Mode

When Disable is selected, RAS is not supported. When Mirror is selected, the motherboard maintains two identical copies of all data in memory for data backup. When Lockstep is selected, the motherboard uses two areas of memory to run the same set of operations in parallel to boost performance. The options are **Disable**, Mirror, and Lockstep Mode.

Memory Rank Sparing

Select Enable to enable memory-sparing support for memory ranks to improve memory performance. The options are **Disabled** and Enabled.

Patrol Scrub

Patrol Scrubbing is a process that allows the CPU to correct correctable memory errors detected on a memory module and send the correction to the requestor (the original source). When this item is set to Enable, the IO hub will read and write back one cache line every 16K cycles, if there is no delay caused by internal processing. By using this method, roughly 64 GB of memory behind the IO hub will be scrubbed every day. The options are **Enable** and Disable.

Patrol Scrub Interval

This feature allows you to decide how many hours the system should wait before the next complete patrol scrub is performed. Use the keyboard to enter a value from 0-24. The Default setting is **24**.

Demand Scrub

Demand Scrubbing is a process that allows the CPU to correct correctable memory errors found on a memory module. When the CPU or I/O issues a demand-read command, and the read data from memory turns out to be a correctable error, the error is corrected and sent to the requestor (the original source). Memory is updated as well. Select Enable to use Demand Scrubbing for ECC memory correction. The options are **Enable** and Disable.

Device Tagging

Select Enable to support device tagging. The options are **Disable** and Enable.

► South Bridge Configuration

The following South Bridge information will display:

► USB Configuration

- USB Module Version
- USB Devices

Legacy USB Support

Select Enabled to support onboard legacy USB devices. Select Auto to disable legacy support if there are no legacy USB devices present. Select Disabled to have all USB devices available for EFI applications only. The options are **Enabled**, Disabled and Auto.

XHCI Hand-Off

This is a work-around solution for operating systems that do not support XHCI (Extensible Host Controller Interface) hand-off. The XHCI ownership change should be claimed by the XHCI driver. The settings are **Enabled** and Disabled.

EHCI Hand-Off

This item is for operating systems that do not support Enhanced Host Controller Interface (EHCI) hand-off. When this item is enabled, EHCI ownership change will be claimed by the EHCI driver. The settings are Enabled and **Disabled**.

Port 60/64 Emulation

Select Enabled to support I/O port 60h/64h emulation, which will provide complete legacy USB keyboard support for the operating systems that do not support legacy USB devices. The options are Disabled and **Enabled**.

USB 3.0 Support

Select Enabled for USB 3.0 support. The options are Smart Auto, Auto, Enabled, and **Disabled**.

EHCI1

Select Enabled to enable EHCI (Enhanced Host Controller Interface) support on USB 2.0 connector #1 (-at least one USB 2.0 connector should be enabled for EHCI support.) The options are Disabled and **Enabled**.

EHCI2

Select Enabled to enable EHCI (Enhanced Host Controller Interface) support on USB 2.0 connector #2 (-at least one USB 2.0 connector should be enabled for EHCI support.) The options are Disabled and **Enabled**.

►SATA Configuration

When this submenu is selected, AMI BIOS automatically detects the presence of the SATA devices that are supported by the Intel PCH chip and displays the following items:

SATA Controller

Select Enabled to enable the onboard SATA controller supported by the Intel PCH chip. The options are **Enabled** and Disabled.

Configure SATA as

Select IDE to configure a SATA drive specified by the user as an IDE drive. Select AHCI to configure a SATA drive specified by the user as an AHCI drive. Select RAID to configure a SATA drive specified by the user as a RAID drive. The options are IDE, **AHCI**, and RAID.

**If the item above "Configure SATA as" is set to AHCI, the following items will display:*

Support Aggressive Link Power Management

When this item is set to Enabled, the SATA AHCI controller manages the power usage of the SATA link. The controller will put the link to a low power state when the I/O is inactive for an extended period of time, and the power state will return to normal when the I/O becomes active. The options are **Enabled** and Disabled.

SATA Port 0~ Port 5

This item displays the information of a SATA device installed on the SATA port specified by the user.

- Model number of drive and capacity
- Software Preserve

Port 0~ Port 5

Select Enabled to enable a SATA port specified by the user. The options are Disabled and **Enabled**.

Spin Up Device

On an edge detect from 0 to 1, set this item to allow the PCH to initialize the device. The options are Enabled and **Disabled**.

SATA Device Type

Use this item to specify if the SATA port specified by the user should be connected to a Solid State drive or a Hard Disk Drive. The options are **Hard Disk Drive** and Solid State Drive.

**If the item above "Configure SATA as" is set to IDE, the following items will display:*

SATA Port 0~ Port 5

This item displays the information of a SATA device installed on the SATA port specified by the user.

- Software Preserve

SATA Device Type (Available when a SATA port is detected)

Use this item to specify if the SATA port specified by the user should be connected to a Solid State drive or a Hard Disk Drive. The options are **Hard Disk Drive** and Solid State Drive.

**If the item above "Configure SATA as" is set to RAID, the following items will display:*

Support Aggressive Link Power Management

When this item is set to Enabled, the SATA AHCI controller manages the power usage of the SATA link. The controller will put the link to a low power state when the I/O is inactive for an extended period of time, and the power state will return to normal when the I/O becomes active. The options are **Enabled** and Disabled.

SATA RAID Option ROM/UEFI Driver

Select EFI to load the EFI driver for system boot. Select Legacy to load a legacy OPROM for system boot. The options are Disabled, EFI, and **Legacy**.

SATA/sSATA RAID Boot Select

Select SATA Controller to boot the system from a SATA RAID device. Select sSATA Controller to boot the system from a sSATA RAID device. Select Both to boot the system either from a SATA RAID device or from an sSATA RAID device. Please note that the option-Both is not supported by the Windows Server 2012/R2 OS. The options are None, Both, SATA Controller, and **sSATA Controller**.

Serial ATA Port 0~ Port 5

This item displays the information of a SATA device installed on the SATA port specified by the user.

- Model number of drive and capacity
- Software Preserve

Port 0~ Port 5

Select Enabled to enable a SATA port specified by the user. The options are Disabled and **Enabled**.

Spin Up Device

On an edge detect from 0 to 1, set this item to allow the PCH to start a COMRESET initialization to the device. The options are Enabled and **Disabled**.

SATA Device Type

Use this item to specify if the SATA port specified by the user should be connected to a Solid State drive or a Hard Disk Drive. The options are **Hard Disk Drive** and Solid State Drive.

►sSATA Configuration

When this submenu is selected, AMI BIOS automatically detects the presence of the SATA devices that are supported by the PCH-sSATA controller and displays the following items:

sSATA Controller

This item enables or disables the onboard SATA controller supported by the Intel PCH-sSATA controller. The options are **Enabled** and Disabled.

Configure sSATA as

Select IDE to configure an sSATA drive specified by the user as an IDE drive. Select AHCI to configure an sSATA drive specified by the user as an AHCI drive. Select RAID to configure an sSATA drive specified by the user as a RAID drive. The options are IDE, **AHCI**, and RAID.

**If the item above "Configure sSATA as" is set to AHCI, the following items will display:*

Support Aggressive Link Power Management

When this item is set to Enabled, the SATA AHCI controller manages the power usage of the SATA link. The controller will put the link to a low power state when the I/O is inactive for an extended period of time, and the power state will return to normal when the I/O becomes active. The options are **Enabled** and Disabled.

sSATA Port 0~ Port 3

This item displays the information detected on the installed on the sSATA port. specified by the user.

- Model number of drive and capacity

sSATA Port 0~ Port 3

Select Enabled to enable an sSATA port specified by the user. The options are Disabled and **Enabled**.

Spin Up Device

On an edge detect from 0 to 1, set this item to allow the PCH to start a COMRESET initialization to the device. The options are Enabled and **Disabled**.

Device Type

Use this item to specify if the sSATA port specified by the user should be connected to a Solid State drive or a Hard Disk Drive. The options are **Hard Disk Drive** and Solid State Drive.

**If the item above "Configure sSATA as" is set to IDE, the following items will display:*

sSATA Port 0~ Port 3

This item indicates that an sSATA port specified by the user is installed (present) or not.

sSATA Device Type (Available when a sSATA port is detected)

Use this item to specify if the sSATA port specified by the user should be connected to a Solid State drive or a Hard Disk Drive. The options are **Hard Disk Drive** and Solid State Drive.

**If the item above "Configure sSATA as" is set to RAID, the following items will display:*

Support Aggressive Link Power Management

When this item is set to Enabled, the SATA AHCI controller manages the power usage of the sSATA link. The controller will put the link to a low power state when the I/O is inactive for an extended period of time, and the power state will return to normal when the I/O becomes active. The options are **Enabled** and Disabled.

sSATA RAID Option ROM/UEFI Driver

Select EFI to load the EFI driver for system boot. Select Legacy to load a legacy OPROM for system boot. The options are Disabled, EFI, and **Legacy**.

SATA/sSATA RAID Boot Select

Select SATA Controller to boot the system from a SATA RAID device. Select sSATA Controller to boot the system from a sSATA RAID device. Select Both to boot the system either from a SATA RAID device or from an sSATA RAID device. Please note that the option-Both is not supported by the Windows Server 2012/R2 OS. The options are None, Both, SATA Controller, and **sSATA Controller**.

sSATA Port 0~ Port 3

Select Enabled to enable an sSATA port specified by the user. The options are Disabled and Enabled.

Spin Up Device

On an edge detect from 0 to 1, set this item to allow the PCH to start a COMRESET initialization to the device. The options are Enabled and **Disabled**.

Device Type

Use this item to specify if the sSATA port specified by the user should be connected to a Solid State drive or a Hard Disk Drive. The options are **Hard Disk Drive** and Solid State Drive.

► Server ME (Management Engine) Configuration

This feature displays the following system ME configuration settings.

- General ME Configuration
- Operational Firmware Version
- Recovery Firmware Version
- ME Firmware Features
- ME Firmware Status #1
- ME Firmware Status #2
 - Current State
 - Error Code

Altitude

This item indicates the altitude of this machine that is above the sea level. The value is shown in meters. If the value is unknown, enter the number "**8000000**".

MCTP (Management Component Transport Protocol) Bus Owner

This item indicates the location of the MCTP Bus owner. Enter 0's to all fields to disable the MCTP Bus owner.

► PCIe/PCI/PnP Configuration

PCI Latency Timer

Use this item to configure the PCI latency timer for a device installed on a PCI bus. Select 32 to set the PCI latency timer to 32 PCI clock cycles. The options are **32**, 64, 96, 128, 160, 192, 224, and 248 (PCI Bus Clocks).

PERR# Generation

Select Enabled to allow a PCI device to generate a PERR (PCI/PCI-E Parity Error) number for a PCI bus error event. The options are Enabled and **Disabled**.

SERR# Generation

Select Enabled to allow a PCI device to generate an SERR (System Error) number for a PCI bus error event. The options are Enabled and **Disabled**.

PCI PERR/SERR Support

Select Enabled to support PERR (PCI/PCI-E Parity Error)/SERR (System Error) runtime error reporting for a PCI/PCI-E slot. The options are Enabled and **Disabled**.

Above 4G Decoding (Available if the system supports 64-bit PCI decoding)

Select Enabled to decode a PCI device that supports 64-bit in the space above 4G Address. The options are Enabled and **Disabled**.

SR-IOV (Available if the system supports Single-Root Virtualization)

Select Enabled for Single-Root IO Virtualization support. The options are Enabled and **Disabled**.

Maximum Payload

Select Auto for the system BIOS to automatically set the maximum payload value for a PCI-E device to enhance system performance. The options are **Auto**, 128 Bytes, 256 Bytes, 512 Bytes, 1024 Bytes, 2048 Bytes, and 4096 Bytes.

Maximum Read Request

Select Auto for the system BIOS to automatically set the maximum size for a read request for a PCI-E device to enhance system performance. The options are **Auto**, 128 Bytes, 256 Bytes, 512 Bytes, 1024 Bytes, 2048 Bytes, and 4096 Bytes.

ASPM Support

Use this item to set the Active State Power Management (ASPM) level for a PCI-E device. Select Auto for the system BIOS to automatically set the ASPM level based on the system configuration. Select Disabled to disable ASPM support. The options are **Disabled** and Auto.

Warning: Enabling ASPM support may cause some PCI-E devices to fail!

MMIOHBase

Use this item to select the I/O base memory size according to memory-address mapping for the PCH chip. The base memory size must be between 4032G to 4078G. The options are **56T**, 48T, 24T, 2T, 512G, and 256G.

MMIO High Size

Use this item to select the high I/O memory size according to memory-address mapping for the PCH chip. The options are **256G**, 128G, 512G, and 1024G.

PCI Devices Option ROM Setting

CPU1 Slot1 PCI-E x8 OPROM/CPU1 Slot2 PCI-E x16 OPROM/CPU1 Slot3 PCI-E x8 OPROM/CPU2 Slot4 PCI-E x16 OPROM/CPU2 Slot5 PCI-E x8 OPROM/CPU2 Slot6 PCI-E x16 OPROM/CPU2 Slot7 PCI-E x16 OPROM/ Onboard Video Option ROM

Select Enabled to enable Option ROM support to boot the computer using a device installed on the slot specified by the user. The options are Disabled, **Legacy**, and EFI.

Onboard LAN Option ROM Type

Select Enabled to enable Option ROM support to boot the computer using a device installed on the slot specified by the user. The options are **Legacy** and EFI.

VGA Priority

Use this item to select the graphics device to be used as the primary video display for system boot. The options are **Onboard** and Offboard.

Onboard LAN1 Option ROM/Onboard LAN2 Option ROM

Use this option to select the type of device installed in LAN Port1 or LAN Port2 for system boot. The default setting for LAN1 Option ROM is **PXE**, and for LAN2 Option ROM is **Disabled**.

Network Stack

Select Enabled to enable PXE (Preboot Execution Environment) or UEFI (Unified Extensible Firmware Interface) for network stack support. The options are Enabled and **Disabled**.

► Super IO Configuration

Super IO Chip AST2400

► Serial Port 1 Configuration/Serial Port 2 Configuration

Serial Port 1/Serial Port 2

Select **Enabled** to enable the onboard serial port specified by the user. The options are **Enabled** and **Disabled**.

Device Settings

This item displays the base I/O port address and the Interrupt Request address for a serial port specified by the user. The default setting for Serial Port 1 is IO=3F8h IRQ=4; for Serial Port 2 is IO=2F8h, IRQ=3.

Change Port 1 Settings/Change Port 2 Settings

This feature specifies the base I/O port address and the Interrupt Request address of Serial Port 1 or Serial Port 2. Select **Auto** for the BIOS to automatically assign the base I/O and IRQ address to a serial port specified.

The options for Serial Port 1 are **Auto**, (IO=3F8h; IRQ=4), (IO=3F8h; IRQ=3, 4, 5, 6, 7, 10, 11, 12), (IO=2F8h; IRQ=3, 4, 5, 6, 7, 10, 11, 12); (IO=3E8h; IRQ=3, 4, 5, 6, 7, 10, 11, 12), and (IO=2E8h; IRQ=3, 4, 5, 6, 7, 10, 11, 12).

The options for Serial Port 2 are **Auto**, (IO=2F8h; IRQ=3), (IO=3F8h; IRQ=3, 4, 5, 6, 7, 10, 11, 12), (IO=2F8h; IRQ=3, 4, 5, 6, 7, 10, 11, 12); (IO=3E8h; IRQ=3, 4, 5, 6, 7, 10, 11, 12), and (IO=2E8h; IRQ=3, 4, 5, 6, 7, 10, 11, 12).

Device Mode

Use this item to select the SUART Clock source for a serial port specified by the user. The options are **24MHz/13** and **24MHz**.

Serial Port 2 Attribute

Select **SOL** to use COM Port 2 as a Serial_Over_LAN (SOL) port for console redirection. The options are **COM** and **SOL**.

► Serial Port Console Redirection

COM 1

COM 1 Console Redirection

Select Enabled to enable COM Port 1 Console Redirection, which will allow a client machine to be connected to a host machine at a remote site for networking. The options are **Disabled** and Enabled.

**If the item above set to Enabled, the following items will become available for configuration:*

► COM1 Console Redirection Settings

Terminal Type

Use this item to select the target terminal emulation type for Console Redirection. Select VT100 to use the ASCII Character set. Select VT100+ to add color and function key support. Select ANSI to use the Extended ASCII Character set. Select VT-UTF8 to use UTF8 encoding to map Unicode characters into one or more bytes. The options are ANSI, VT100, **VT100+**, and VT-UTF8.

Bits Per second

Use this item to set the transmission speed for a serial port used in Console Redirection. Make sure that the same speed is used in the host computer and the client computer. A lower transmission speed may be required for long and busy lines. The options are 9600, 19200, 38400, 57600 and **115200** (bits per second).

Data Bits

Use this item to set the data transmission size for Console Redirection. The options are 7 (Bits) and **8 (Bits)**.

Parity

A parity bit can be sent along with regular data bits to detect data transmission errors. Select Even if the parity bit is set to 0, and the number of 1's in data bits is even. Select Odd if the parity bit is set to 0, and the number of 1's in data bits is odd. Select None if you do not want to send a parity bit with your data bits in transmission. Select Mark to add a mark as a parity bit to be sent along with the data bits. Select Space to add a Space as a parity bit to be sent with your data bits. The options are **None**, Even, Odd, Mark and Space.

Stop Bits

A stop bit indicates the end of a serial data packet. Select 1 Stop Bit for standard serial data communication. Select 2 Stop Bits if slower devices are used. The options are **1** and **2**.

Flow Control

Use this item to set the flow control for Console Redirection to prevent data loss caused by buffer overflow. Send a "Stop" signal to stop sending data when the receiving buffer is full. Send a "Start" signal to start sending data when the receiving buffer is empty. The options are **None** and Hardware RTS/CTS.

VT-UTF8 Combo Key Support

Select Enabled to enable VT-UTF8 Combination Key support for ANSI/VT100 terminals. The options are **Enabled** and Disabled.

Recorder Mode

Select Enabled to capture the data displayed on a terminal and send it as text messages to a remote server. The options are **Disabled** and Enabled.

Resolution 100x31

Select Enabled for extended-terminal resolution support. The options are Disabled and **Enabled**.

Legacy OS Redirection Resolution

Use this item to select the number of rows and columns used in Console Redirection for legacy OS support. The options are 80x24 and **80x25**.

Putty KeyPad

Use this item to select Function Keys and KeyPad settings for Putty, which is a terminal emulator designed for the Windows OS. The options are **VT100**, LINUX, XTERMR6, SCO, ESCN, and VT400.

Redirection After BIOS Post

Use this item to enable or disable legacy Console Redirection after BIOS POST (Power-On Self-Test). When "Bootloader" is selected, legacy Console Redirection is disabled before booting the OS. When "Always Enable" is selected, legacy Console Redirection remains enabled while the OS boots up. The options are **Always Enable** and Bootloader.

SOL/COM2

SOL/COM2 Console Redirection

Select Enabled to use the SOL port for Console Redirection. The options are **Enabled** and Disabled.

**If the item above set to Enabled, the following items will become available for user's configuration:*

► SOL/COM2 Console Redirection Settings

Use this feature to specify how the host computer will exchange data with the client computer, which is the remote computer used by the user.

Terminal Type

Use this feature to select the target terminal emulation type for Console Redirection. Select VT100 to use the ASCII Character set. Select VT100+ to add color and function key support. Select ANSI to use the Extended ASCII Character Set. Select VT-UTF8 to use UTF8 encoding to map Unicode characters into one or more bytes. The options are ANSI, VT100, **VT100+**, and VT-UTF8.

Bits Per second

Use this feature to set the transmission speed for a serial port used in Console Redirection. Make sure that the same speed is used in the host computer and the client computer. A lower transmission speed may be required for long and busy lines. The options are 9600, 19200, 38400, 57600 and **115200** (bits per second).

Data Bits

Use this feature to set the data transmission size for Console Redirection. The options are 7 (Bits) and **8 (Bits)**.

Parity

A parity bit can be sent along with regular data bits to detect data transmission errors. Select Even if the parity bit is set to 0, and the number of 1's in data bits is even. Select Odd if the parity bit is set to 0, and the number of 1's in data bits is odd. Select None if you do not want to send a parity bit with your data bits in transmission. Select Mark to add a mark as a parity bit to be sent along with the data bits. Select Space to add a Space as a parity bit to be sent with your data bits. The options are **None**, Even, Odd, Mark and Space.

Stop Bits

A stop bit indicates the end of a serial data packet. Select 1 Stop Bit for standard serial data communication. Select 2 Stop Bits if slower devices are used. The options are **1** and **2**.

Flow Control

Use this feature to set the flow control for Console Redirection to prevent data loss caused by buffer overflow. Send a "Stop" signal to stop sending data when the receiving buffer is full. Send a "Start" signal to start data-sending when the receiving buffer is empty. The options are **None** and Hardware RTS/CTS.

VT-UTF8 Combo Key Support

Select Enabled to enable VT-UTF8 Combination Key support for ANSI/VT100 terminals. The options are **Enabled** and Disabled.

Recorder Mode

Select Enabled to capture the data displayed on a terminal and send it as text messages to a remote server. The options are **Disabled** and Enabled.

Resolution 100x31

Select Enabled for extended-terminal resolution support. The options are Disabled and **Enabled**.

Legacy OS Redirection Resolution

Use this feature to select the number of rows and columns used in Console Redirection for legacy OS support. The options are 80x24 and **80x25**.

Putty KeyPad

This feature selects Function Keys and KeyPad settings for Putty, which is a terminal emulator designed for the Windows OS. The options are **VT100**, LINUX, XTERMR6, SCO, ESCN, and VT400.

Redirection After BIOS Post

Use this feature to enable or disable legacy Console Redirection after BIOS POST (Power-On Self-Test). When this feature is set to Bootloader, legacy Console Redirection is disabled before booting the OS. When this feature is set to Always Enable, legacy Console Redirection remains enabled upon OS boot. The options are **Always Enable** and Bootloader.

Legacy Console Redirection

The submenu allows the user to configure Legacy Console Redirection settings so that legacy devices can be used for Console Redirection.

► Legacy Console Redirection Settings

Use this feature to specify how the host computer will communicate with the client compute at a remote site via legacy devices.

Legacy Serial Redirection Port

The feature selects a legacy serial port to be used for Console Redirection. The options are **COM1 Console Redirection** and COM2/SOL Console Redirection.

Serial Port for Out-of-Band Management/Windows Emergency Management Services (EMS)

The submenu allows the user to configure Console Redirection settings to support Out-of-Band Serial Port management.

(EMS) Console Redirection

Select Enabled to use a COM port selected by the user for EMS Console Redirection. The options are Enabled and **Disabled**.

*If the item above set to Enabled, the following items will become available for user's configuration:

► EMS Console Redirection Settings (Available when EMS Console Redirection is enabled)

Use this feature to specify how the host computer will exchange data with the client computer, which is the remote computer used by the user.

Out-of-Band Management Port

The feature selects a serial port in a client server to be used by the Windows Emergency Management Services (EMS) to communicate with a remote host server. The options are **COM1 (Console Redirection)** and COM2/SOL (Console Redirection).

Terminal Type

Use this feature to select the target terminal emulation type for Console Redirection. Select VT100 to use the ASCII character set. Select VT100+ to add color and function key support. Select ANSI to use the extended ASCII character set. Select VT-UTF8 to use UTF8 encoding to map Unicode characters into one or more bytes. The options are ANSI, VT100, VT100+, and **VT-UTF8**.

Bits Per Second

This item sets the transmission speed for a serial port used in Console Redirection. Make sure that the same speed is used in both host computer and the client computer. A lower transmission speed may be required for long and busy lines. The options are 9600, 19200, 57600, and **115200** (bits per second).

Flow Control

Use this item to set the flow control for Console Redirection to prevent data loss caused by buffer overflow. Send a "Stop" signal to stop data-sending when the receiving buffer is full. Send a "Start" signal to start data-sending when the receiving buffer is empty. The options are **None**, Hardware RTS/CTS, and Software Xon/Xoff.

The following settings will be displayed:

Data Bits, Parity, Stop Bits

► Trusted Computing (Available when a TPM device is installed and detected by the BIOS)

Configuration

Security Device Support

If this feature and the TPM jumper on the motherboard are both set to Enabled, onboard security devices will be enabled for TPM (Trusted Platform Module) support to enhance data integrity and network security. Please reboot the system for a change on this setting to take effect. The options are Enabled and **Disabled**.

TPM State

Select Enabled to use TPM (Trusted Platform Module) settings to enhance system data security. Please reboot your system for any change on the TPM state to take effect. The options are Disabled and **Enabled**.

Pending Operation

Use this item to schedule a TPM-related operation to be performed by a security device for system data integrity. Your system will reboot to carry out a pending TPM operation. The options are **0**, Enable Take Ownership, Disable Take Ownership, and TPM Clear.

Note: Your system will reboot to carry out a pending TPM operation.

Current Status Information

This item displays the status of the TPM support on this motherboard.

► Intel TXT (LT-SX) Configuration

This submenu allows the user to configure the following TXT settings.

TXT Support

Select Enabled to enable Intel Trusted Execution Technology (TXT) support. The options are **Disabled** and Enabled.

Note: If the option for this item (TXT Support) is set to Enabled, be sure to disable EV DFX (Device Function On-Hide) support for the system to work properly. (EV DFX is under "I/O Configuration" in the "Chipset/North Bridge" submenu on Page 4-11).

► ACPI Settings

WHEA Support

Select Enabled to support the Windows Hardware Error Architecture (WHEA) platform and provide a common infrastructure for the system to handle hardware errors within the Windows OS environment to reduce system crashes and to enhance system recovery and health monitoring. The options are **Enabled** and Disabled.

High Precision Event Timer

Select Enabled to activate the High Precision Event Timer (HPET) that produces periodic interrupts at a much higher frequency than a Real-time Clock (RTC) does in synchronizing multimedia streams, providing smooth playback and reducing the dependency on other timestamp calculation devices, such as an x86 RDTSC Instruction embedded in the CPU. The High Performance Event Timer is used to replace the 8254 Programmable Interval Timer. The options are **Enabled** and Disabled.

NUMA (Available when the OS supports this feature)

Select Enabled to enable Non-Uniform Memory Access support to enhance system performance. The options are **Enabled** and Disabled.

PCI AER (Advanced Error-Reporting) Support

Select Enabled to support Advanced Error-Reporting for onboard PCI devices. The options are **Disabled** and Enabled.

► **iSCSI Configuration**

This item displays iSCSI configuration information:

iSCSI Initiator Name

Use this item to enter the name of the iSCSI Initiator, which is a unique name used in the world. The name must in the IQN format. The following submenu will be available for configuration:

► **Add an Attempt**

► **Delete Attempts**

► **Change Attempt Order**

7-4 Event Logs

This submenu allows the user to configure Event Log settings.

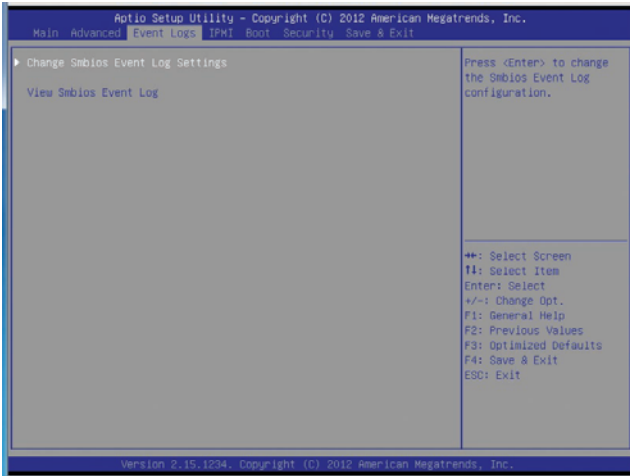

► Change SMBIOS Event Log Settings

This feature allows the user to configure SMBIOS Event settings.

Enabling/Disabling Options

SMBIOS Event Log

Select Enabled to enable SMBIOS (System Management BIOS) Event Logging during system boot. The options are **Enabled** and Disabled.

Runtime Error Logging Support

Select Enable to support Runtime Error logging. The options are **Enabled** and Disabled. If this item is set to Enabled, the following item will be available for configuration:

Memory Corrected Error Enabling (Available when the item above-Runtime Error Logging Support is set to Enabled)

Select Enabled to log an event whenever a memory error is corrected. The options are **Enabled** and Disabled.

PCI-E Error Enable (Available when the item above-Runtime Error Logging Support is set to Enabled)

Select Enabled to log an event when an error has occurred on a device installed in a PCI-E slot. The options are Enabled and **Disabled**.

Memory Correctable Error Threshold (Available when the item above- Runtime Error Logging Support is set to Enabled)

Use this item to specify the threshold value for correctable memory-error logging, which sets a limit on the maximum number of events that can be logged in the memory-error log at a given time. The default setting is **10**.

Erasing Settings

Erase Event Log

Select Yes to erase all error events in the SMBIOS (System Management BIOS) log before an event logging is initialized at bootup. The options are **No**, Yes, Next reset, and Yes, every reset.

When Log is Full

Select Erase Immediately to immediately erase all errors in the SMBIOS event log when the event log is full. Select Do Nothing for the system to do nothing when the SMBIOS event log is full. The options are **Do Nothing** and Erase Immediately.

SMBIOS Event Log Standard Settings

Log System Boot Event

Select Enabled to log system boot events. The options are **Disabled** and Enabled.

MECI (Multiple Event Count Increment)

Enter the increment value for the multiple event counter. Enter a number between 1 to 255. The default setting is **1**.

METW (Multiple Event Count Time Window)

This item is used to determine how long (in minutes) the multiple event counter should wait before generating a new event log. Enter a number between 0 to 99. The default setting is **60**.

Note: Please reboot the system for the changes to take effect.

►View SMBIOS Event Log

This item allows the user to view the event in the SMBIOS event log. The following categories are displayed:

Date/Time/Error Code/Severity

7-5 IPMI

This submenu allows the user to configure Intelligent Platform Management Interface (IPMI) settings.



BMC (Baseboard Management Controller) Firmware Revision

This item indicates the BMC firmware revision used in your system.

Status of BMC

This item indicates the status of the onboard BMC chip installed in your system.

► System Event Log

Enabling/Disabling Options

SEL Components

Select Enabled to enable all system event logging support at bootup. The options are **Enabled** and Disabled.

Erasing Settings

Erase SEL

Select Yes, On next reset to erase all system event logs upon next system reboot.
 Select Yes, On every reset to erase all system event logs upon each system reboot.
 Select No to keep all system event logs after each system reboot. The options are **No**, Yes, On next reset, and Yes, On every reset.

When SEL is Full

This feature allows the user to determine what the AMI BIOS should do when the system event log is full. Select Erase Immediately to erase all events in the log when the system event log is full. The options are **Do Nothing** and Erase Immediately.

Note: After making changes on a setting, be sure to reboot the system for the changes to take effect.

►BMC Network Configuration

The following items will be displayed:

- IPMI LAN Selection
- IPMI Network Link Status

Update IPMI LAN Configuration

Select Yes for the system BIOS to automatically reset the following IPMI settings upon next system boot. The options are Yes and **No**.

Configuration Address Source (Available when the item above - Update IPMI LAN Configuration is set to Yes)

Use this item to select the IP address source for this computer. If Static is selected, you will need to know the IP address of this computer and enter it to the system manually in the field. If DHCP is selected, AMI BIOS will search for a DHCP (Dynamic Host Configuration Protocol) server attached to the network and request the next available IP address for this computer. The options are **DHCP** and Static.

Station IP Address

This item displays the Station IP address for this computer. This should be in decimal and in dotted quad form (i.e., 192.168.10.253).

Subnet Mask

This item displays the sub-network that this computer belongs to. The value of each three-digit number is separated by dots and it should not exceed 255.

Station MAC Address

This item displays the Station MAC address for this computer. Mac addresses are 6 two-digit hexadecimal numbers.

Gateway IP Address

This item displays the Gateway IP address for this computer. This should be in decimal and in dotted quad form (i.e., 192.168.10.253).

7-6 Security Settings

This submenu allows the user to configure the following security settings for the system.

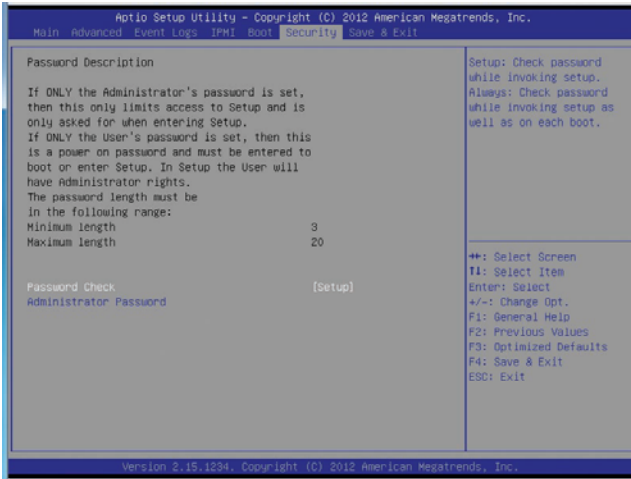

Administrator Password

Use this feature to set the administrator password which is required before entering the BIOS setup utility. The length of the password should be from 3 characters to 20 characters long.

User Password (Available after an Administrator Password is entered)

Use this feature to set the user password which is required to enter the BIOS setup utility. The length of the password should be from 3 characters to 20 characters long.

7-7 Boot Settings

This submenu allows the user to configure Boot settings for this system:

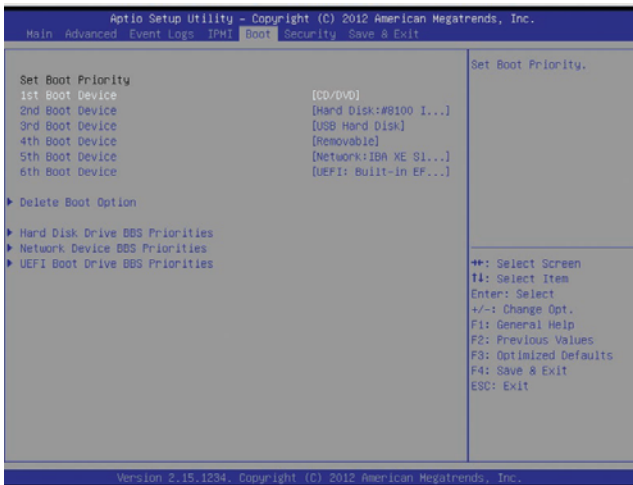

Boot Configuration

Boot Mode Select

Use this item to select the type of device to be used for system boot. The options are Legacy, UEFI, and **Dual**.

Fixed Boot Order Priorities

This option prioritizes the order of bootable devices from which the system will boot. Press <Enter> on each entry from top to bottom to select devices.

When the item above -"Boot Mode Select" is set to **Dual** (default), the following items will be displayed for configuration:

- Boot Option #1 - Boot Option #15

When the item above -"Boot Mode Select" is set to Legacy, the following items will be display for configuration:

- Boot Option #1 - Boot Option #7

When the item above -"Boot Mode Select" is set to UEFI, the following items will be display for configuration:

- Boot Option #1 - Boot Option #8

▶ Delete Boot Option

Use this item to select a boot device to delete from the boot priority list.

Delete Boot Option

Select the target boot device to delete from the boot priority list.

▶ Delete Driver Option

Use this item to select a driver to delete from the boot priority list.

Delete Boot Option

Select the target boot drive to delete from the boot priority list.

▶ Hard Disk Drive BBS Priorities

- Boot Option #1

▶ Network Drive BBS Priorities

- Boot Option #1

▶ UEFI Application Boot Priorities

- UEFI Boot Option #1

7-8 Save & Exit

This submenu allows the user to configure the following Save & Exit settings:

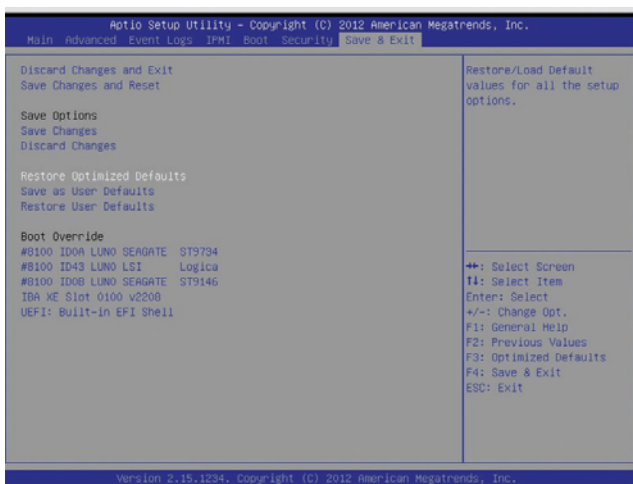

Discard Changes and Exit

Select this item to exit from the BIOS setup without making any permanent changes to the system configuration, and reboot the computer.

Save Changes and Reset

When you have completed the system configuration changes, select this item to leave the BIOS setup utility and reboot the computer for the new system configuration parameters to take effect. Select Yes and press <Enter> to save the changes you've made and reboot the system.

Save Options

Save Changes

When you have completed the system configuration changes, select this item to save all changes made. This will not reset (reboot) the system.

Discard Changes

Select this item to discard all the changes and return to the AMI BIOS setup utility. Select Yes and press <Enter> to discard all changes made.

Restore Defaults

Select this item and press <Enter> to load the manufacture default settings which are designed for maximum system performance but not for maximum stability.

Save As User Defaults

Select this item and press <Enter> to save the current BIOS settings as user's default settings for future use.

Restore User Defaults

Select this item and press <Enter> to retrieve the user-defined default settings that were previously saved to be used as current default settings.

Boot Override

This feature allows the user to override the boot priority sequence in the Boot submenu and immediately boot the system with another device specified by the user. This is a one-time override.

Notes

Appendix A

System Specifications

Note: Unless noted specifications apply to a complete system (all serverboards). There are two serverboard drawer nodes per system.

Processors

Two E5-2600v3 series processors per node in Socket R3 LGA 2011 type sockets

Note: please refer to our website for details on supported processors.

Chipset

One C612 chipset per node

BIOS

128 Mb AMI BIOS® Flash EEPROM per node

Memory Capacity

Each X10DRFF-CG/CTG serverboard node has sixteen (16) DIMM slots supporting up to 1024 GB of LDIMM registered ECC or up to 512 GB of RDIMM at DDR4-2133/1866/1600 MHz speeds and up to 1 GB, 2 GB, 4 GB, 8 GB, 16 GB, 32 GB or 64 GB size at 1.2V voltages.

Note: refer to Section 5-5 for details on installation.

Note: Check the Supermicro website (www.supermicro.com) for the latest memory support information.

SAS/SATA Drive Bays

Each node of the FatTwin F648G2-FC0+/FC0PT+ contains eight (8) SAS3 or eight (8) SATA3 hot-swap drive bays to house up to eight standard 2.5" SAS/SATA drives per node.

PCI Expansion

Each node in the the FatTwin F648G2-FC0+/FC0PT+ server has two expansion slots available for use.

Serverboard

F648G2-FC0+/FC0PT+ serverboard (proprietary form factor)

Dimensions: (LxW) 18.73" (L) x 8.54" (W) (475.74 mm x 216.92 mm)

Chassis

F442BG-R2K04BP (4U rackmount)

Dimensions: (WxHxD) 17.63 x 6.96 x 35 in. (448 x 177 x 889 mm)

Weight

Gross (Bare Bone): 150 lbs (68.04 kg)

System Cooling

The system has eight (8) 8-cm PWM system cooling fans in the rear of the chassis.

Note: The system cooling fans are redundant, but NOT hot-plug.

System Power Ratings

PWS-2K04A-1R) Power Ratings			
Region	Input Power Source	Current Rating	Maximum Output Power
North America	100-120V, 50-60Hz	12.0-10.5A	1100W
	200-240V, 50-60Hz	11.0-9.8A	2000W
International	100-120V, 50-60Hz	12.0-10.5A	1100W
	200-240V, 50-60Hz	10.0-8.3A	1995W

Note: The system power supplies are redundant, hot-plug.

Operating Environment

Operating Temperature: 10°C to 35°C (50°F to 95°F)

Non-operating Temperature: -40°C to 70°C (-40°F to 158°F)

Operating Relative Humidity: 8% to 90% (non-condensing)

Non-operating Relative Humidity: 5 to 95% (non-condensing)

The table below specifies the preferred ambient temperature versus processor support for the FatTwin F648G2-FC0+/FC0PT+ system.

Ambient Temperature versus Porcessor Support			
CPU TDP	35°C	30°C	25°C
145 W		X _{1,3}	X ₃
135 W	X _{1,3}	X _{1,3}	X _{1,2}
120 W	X _{1,3}	X ₃	X _{1,2}
105 W	X _{1,3}	X ₃	X _{1,2}
85 W	X ₃	X ₃	X _{1,2}

Notes:

1. With four 9.5K RPM inner fans per node.
2. With K80/Xeon Phi GPU card installed.
3. With K40/ Xeon Phi GPU card installed.

Note: For Frequency Optimized CPU, please consult technical support.

Regulatory Compliance

Electromagnetic Emissions: FCC Class A, EN 55022 Class A, EN 61000-3-2/-3-3, CISPR 22 Class A

Electromagnetic Immunity: EN 55024/CISPR 24, (EN 61000-4-2, EN 61000-4-3, EN 61000-4-4, EN 61000-4-5, EN 61000-4-6, EN 61000-4-8, EN 61000-4-11)

Safety: CSA/EN/IEC/UL 60950-1 Compliant, UL or CSA Listed (USA and Canada), CE Marking (Europe)

California Best Management Practices Regulations for Perchlorate Materials: This Perchlorate warning applies only to products containing CR (Manganese Dioxide) Lithium coin cells. "Perchlorate Material-special handling may apply. See www.dtsc.ca.gov/hazardouswaste/perchlorate" for further details.

(continued from front)

The products sold by Supermicro are not intended for and will not be used in life support systems, medical equipment, nuclear facilities or systems, aircraft, aircraft devices, aircraft/emergency communication devices or other critical systems whose failure to perform be reasonably expected to result in significant injury or loss of life or catastrophic property damage. Accordingly, Supermicro disclaims any and all liability, and should buyer use or sell such products for use in such ultra-hazardous applications, it does so entirely at its own risk. Furthermore, buyer agrees to fully indemnify, defend and hold Supermicro harmless for and against any and all claims, demands, actions, litigation, and proceedings of any kind arising out of or related to such ultra-hazardous use or sale.