

Information for Lot 9 of ErP (Ecodesign)

This addendum addresses European Union (EU) Ecodesign requirements for servers and storage products. All data and ratings within this addendum are in reference only to the Supermicro product(s) in the manual. The below information conforms to requirements laid down in Annex II of the Commission Regulation 2019/424.

- 3(1)(a): See Section 1.1 of the system manual for the product type.
- 3(1)(b): See the title page and preface of the system manual for the trademark and manufacturer's address.
- 3(1)(c): See the title page of the system manual for product model number(s).
- 3(1)(d): See the serial number on the physical system to determine the year of manufacture.
- 3(1)(e-j): **PSU Efficiency and Power Factor Value (Table) (From 80 Plus report)**

PSU Model #: PWS-3K06G-2R Watts: 3000W	PSU Efficiency				Power Factor
	10 %	20 %	50 %	100 %	
% of Rated Load	10 %	20 %	50 %	100 %	50 %
Single Output (AC-DC)	91.52%	94.62%	96.34%	95.80%	0.9945
Multiple Output (AC-DC)	N/A	N/A	N/A	N/A	N/A

System (EUT) Efficiency in **Idle State** Power (Table)

Representative Configurations	Measured Idle State Power (W)	Calculated Idle Power Allowance (W)
High-End Performance Configuration	2398.2	837.2
Typical Configuration	N/A	N/A
Low-End Performance Configuration	1677.4	589.8

System (EUT) Efficiency in **Active State** Power (Table)

Representative Configurations	Active State Efficiency Score (Effserver)	Minimum Active State Efficiency for 2-Socket Server
High-End Performance Configuration	22.8	9.5
Typical Configuration	N/A	
Low-End Performance Configuration	26.1	

3(1)(k): The operating condition class is **A2**.

Operating condition class	Dry bulb temp °C		Humidity range, non-condensing		Max dew point (°C)	Maximum rate of change (°C/hr)
	Allowable range	Recommended range	Allowable range	Recommended range		
A1	15- 32	18-27	- 12 °C Dew Point (DP) and 8 % relative humidity (RH) to 17 °C DP and 80 % RH	- 9 °C DP to 15 °C DP and 60 % RH	17	5/20
A2	10-35	18-27	- 12 °C DP and 8 % RH to 21 °C DP and 80 % RH	Same as A1	21	5/20
A3	5-40	18-27	- 12 °C DP and 8 % RH to 24 °C DP and 85 % RH	Same as A1	24	5/20
A4	5-45	18-27	- 12 °C DP and 8 % RH to 24 °C DP and 90 % RH	Same as A1	24	5/20

3(1)(l): The idle state power at the higher boundary temperature of the operating conditions class is 2829.9 W.

3(1)(m): The active state efficiency and performance is 22.8.

3(1)(n): There are two methods by which a user can securely delete data from this system. The user performing secure data deletion should be an IT professional. The first is with a Unified Extensible Firmware Interface (UEFI) shell utility. This utility works on X10/X11/H11/H12/M11 motherboard series with onboard SATA/NVMe devices. Any user may access and download this utility through following link:
https://www.supermicro.com/about/policies/disclaimer.cfm?url=/wftp/utility/Lot9_Secure_Data_Deletion_UTILITY/

Download the shell utility package and extract it to a USB flash drive, then plug the drive into the server for which secure data deletion is necessary. Then turn the system on. Navigate to the BIOS setup menu, then place the server system into the UEFI shell environment. Follow the instructions in the README file to invoke the utility and complete the deletion.

The second method is through the secure data deletion tool provided by the original manufacturer of the hard drive. This should be used in a scenario where the shell utility is not applicable. Each manufacturer should have the tool available on their website. If needed, please look on the hard drive label for the name of the manufacturer and model information.

3(1)(o): List of recommended combinations of blade servers with chassis: N/A.

3(1)(p): List of all current SKUs within this product family: AS -8125GS-TNHR.

3(3)(a):

There is no use of cobalt in batteries in this product.

The indicative weight range of neodymium in the HDD is 0.0 if manufactured by Western Digital, and is between 5-25 grams if manufactured by Seagate.

3(3)(b):

Please see the disassembly instructions on the next page.

Illustrated System Disassembly Instructions

Please note: All the illustrations in the below disassembly instructions are for demonstration only. Components shown here may not match exactly with the components in your system.

CAUTION: Always power off the system and unplug the power cord(s) first before disassembling the system!

1. External Data Storage Devices

Type and number of fastenings: One (1) release button and two (2) locking clasps.

Tools required: None.

Procedure:

1. Push the release button on the drive carrier, which will extend the drive carrier handle.
2. Use the drive carrier handle to pull the drive out of the chassis.
3. Unlock the two locking clasps on the side of drive carrier.
4. Lift the drive out of the carrier.

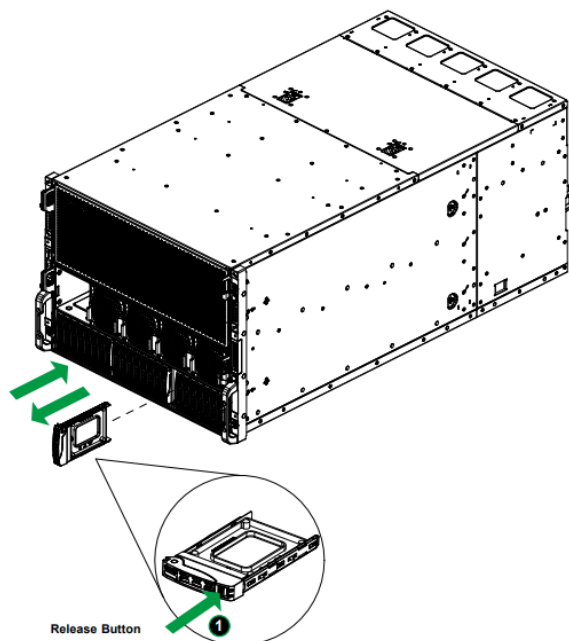

2. Chassis Fans

Type and number of fastenings: Two (2) quick-release tabs per fan.

Tools required: None.

Procedure: Squeeze the quick-release tabs together and pull the fan out of the chassis.

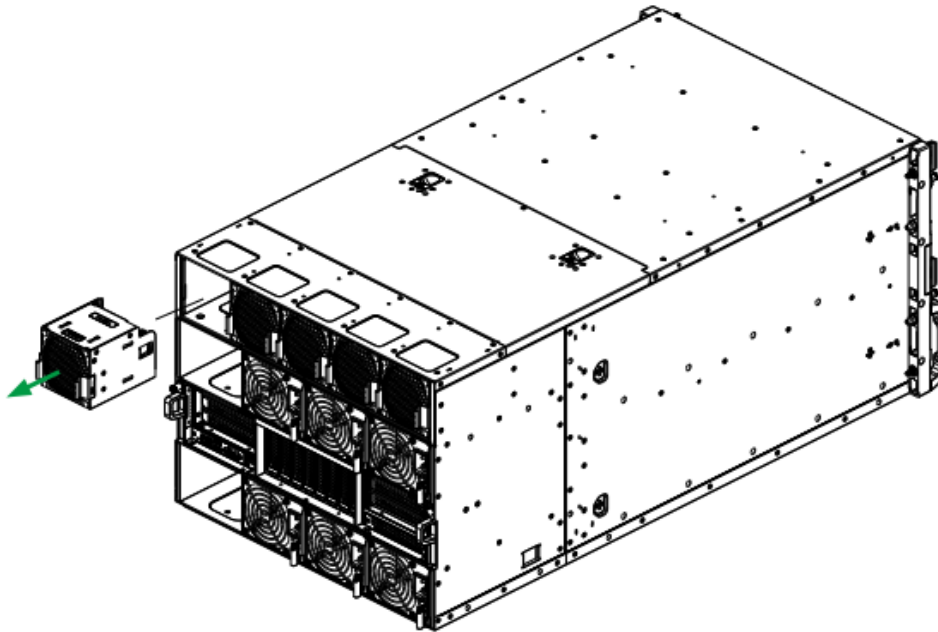

3. Power Supplies / Fan Modules

Type and number of fastenings: One (1) latch per module.

Tools required: None.

Procedure: Unplug the power cord from the power supply (if applicable). Lift the release latch on the back of the power supply module and pull the module straight out.

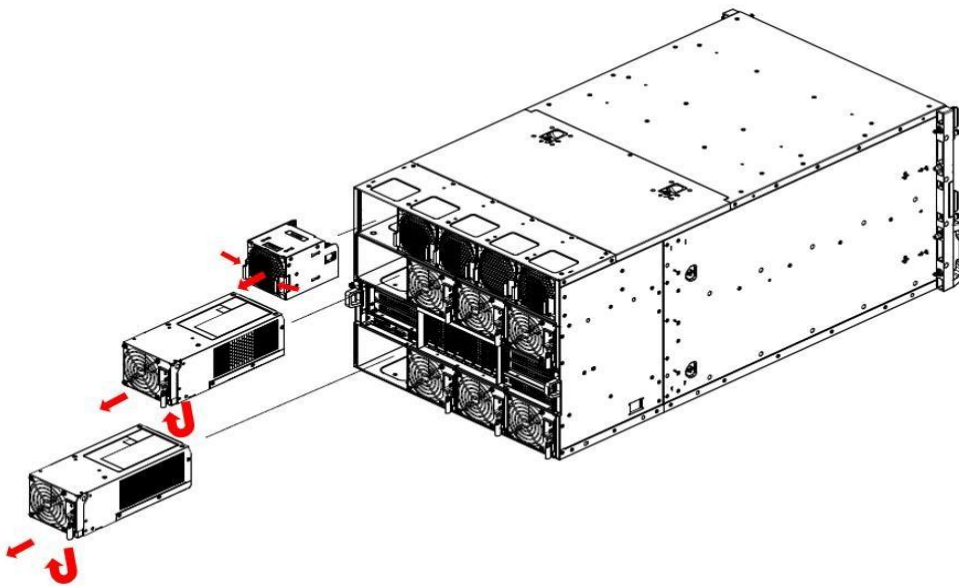

4. Rear PCIe Tray

Type and number of fastenings: Two (2) captive Phillips screws.

Tools required: Screwdriver with PH2 bit.

Procedure: Loosen the two captive Phillips screws from the handle levers, then pull down on both handle levers simultaneously to disengage the rear PCIe tray and pull it out of the chassis.

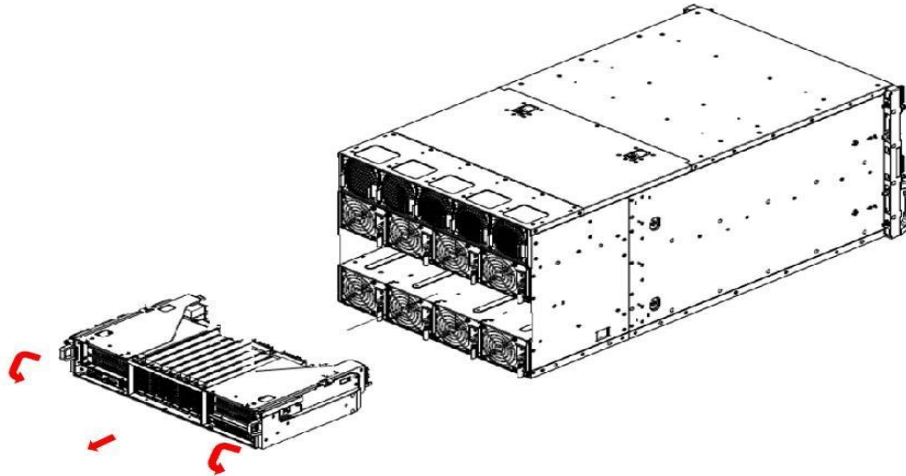

5. Rear PCIe Expansion Carrier and Rear PCIe Riser Card

Type and number of fastenings: Four (4) small Phillips screws per expansion carrier; five (5) large Phillips screws for each PCIe riser card.

Tools required: Screwdriver with PH2 bit.

Procedure: Remove three screws from the top plane of the expansion carrier and one screw from the side wall. Lift the expansion carrier straight up out of the PCIe tray. Remove the five Phillips screws and detach the riser card from the expansion carrier.

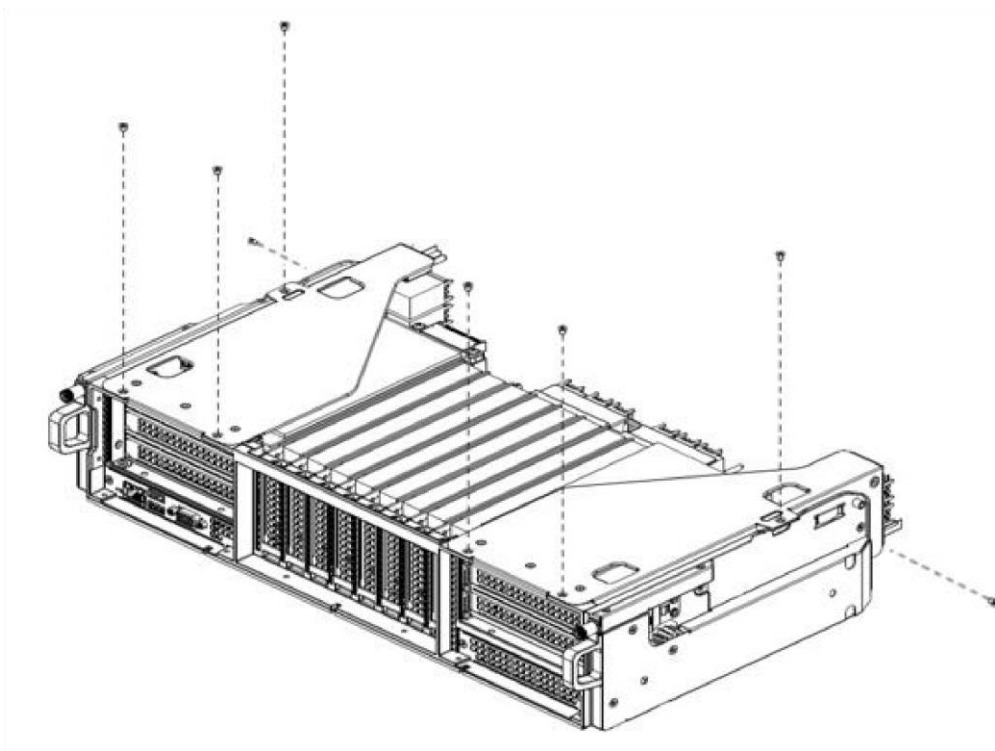

6. Rear Expansion Card

Type and number of fastenings: One (1) large Phillips screw per expansion card installed.

Tools required: Screwdriver with PH2 bit.

Procedure: Remove the Phillips screw from the expansion card rear I/O panel and pull the expansion card out from its corresponding slot.

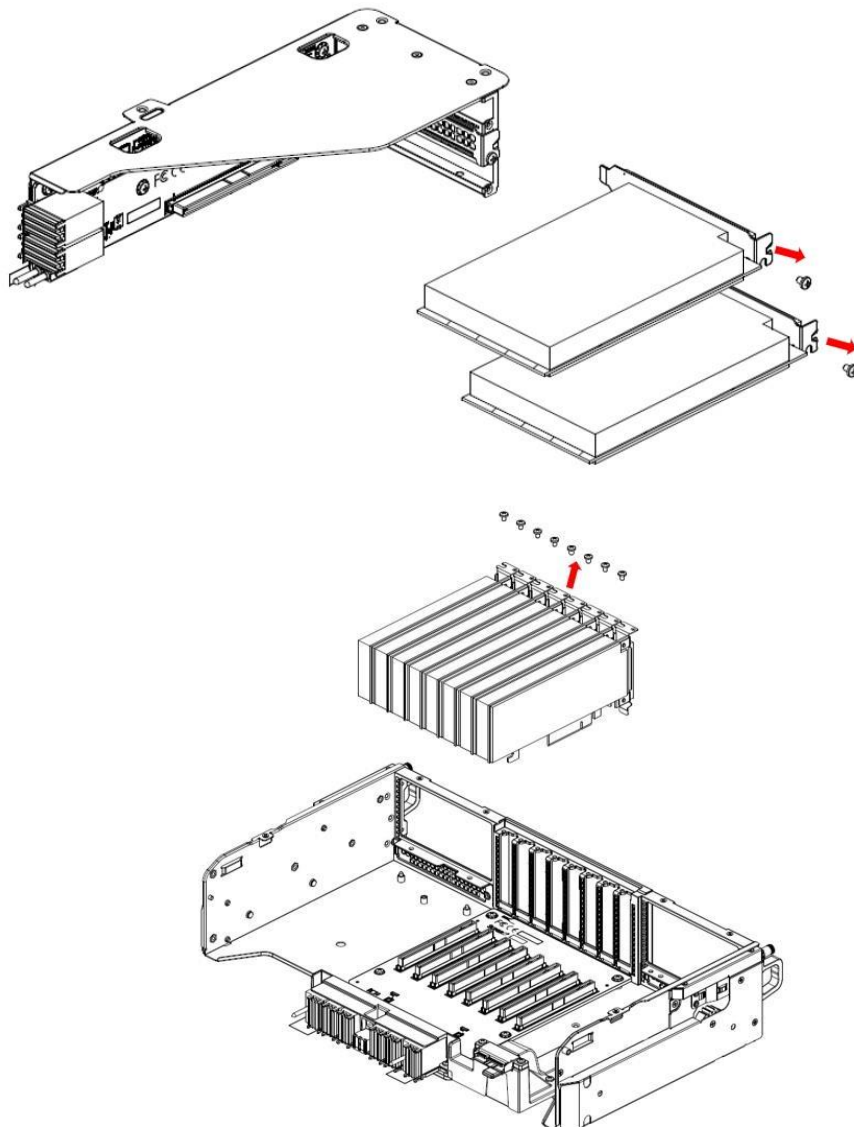

7. Motherboard Tray

Type and number of fastenings: Two (2) captive Phillips screws.

Tools required: Screwdriver with PH2 bit.

Procedure: Loosen the two captive Phillips screws from the handle levers, then pull down on both handle levers simultaneously to disengage the motherboard tray and pull it out of the chassis.

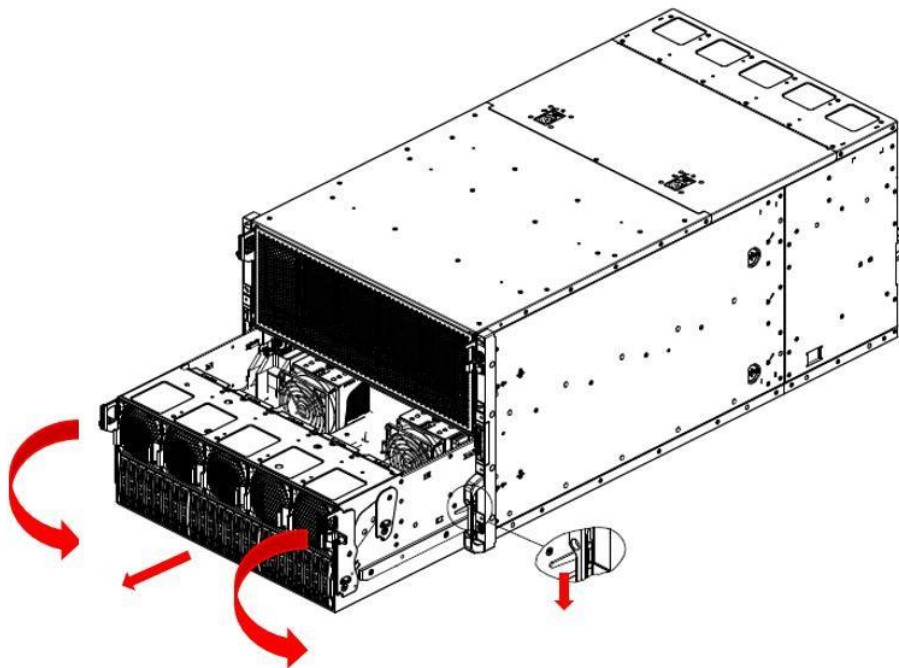

8. Air Shroud

Type and number of fastenings: Three (3) captive Phillips screws, four (4) small Phillips screws, and two (2) long Phillips screws.

Tools required: Screwdriver with PH2 bit.

Procedure:

1. Remove the five black fan louvers by pulling them horizontally away from the interior fan casing, noting the embossed arrow pointing into the motherboard tray.
2. Disconnect the two cables from the fan control board to avoid interference.
3. Loosen the three captive Phillips screws from the top of the air shroud.
4. Remove the four Phillips screws securing the air shroud components to the side of the motherboard tray (two on each side). The central air shroud component will lift up.
5. Slide the left and right air shroud components forward horizontally and then upward diagonally after clearing the side metal brackets.
6. The remaining long and narrow air shroud component is secured in place by two long Phillips screws; remove them and lift up.

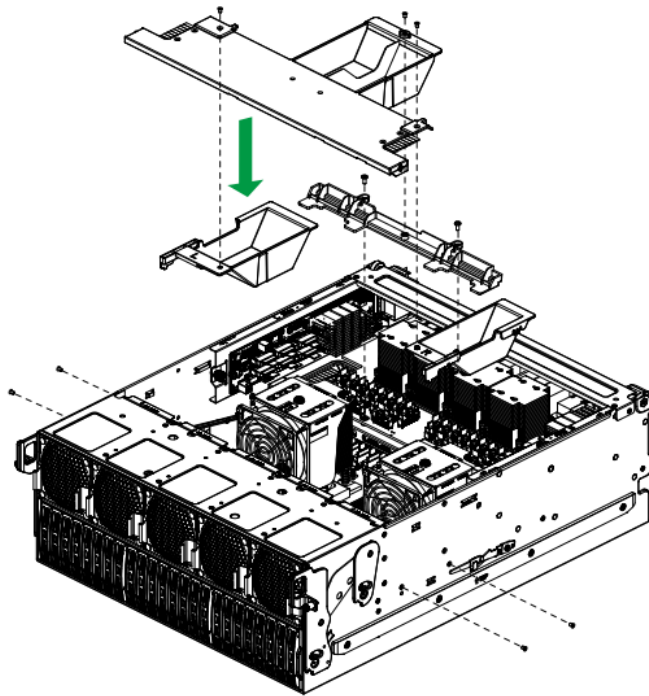

9. Memory

Type and number of fastenings: Two (2) latches per memory module.

Tools required: None.

Procedure: Press both release tabs on the ends of the memory module to unlock it. Once the module is loosened, remove it from the memory slot.

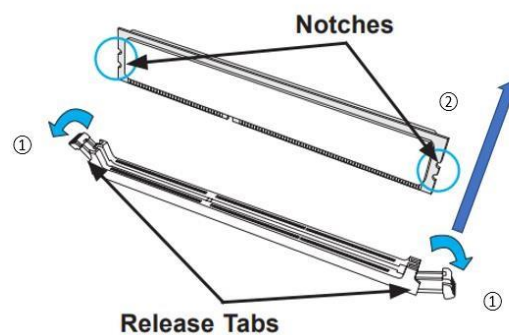

10. Processor

Type and number of fastenings: Six T30 screws.

Tools required: Screwdriver with T30 Torx bit.

Procedure:

1. Using a T30-bit screwdriver, remove the heatsink attached to the top of the processor package in the order of 6, 5, 4, 3, 2, then 1, as shown in the picture below.

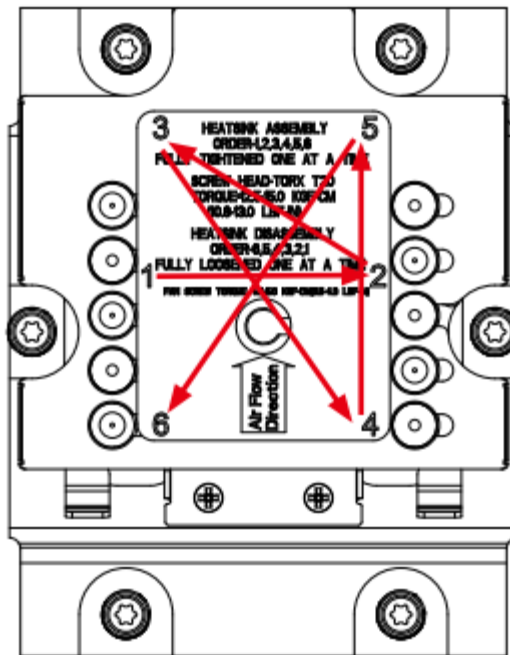

2. Unscrew the plate and lift the force frame up to vertical.

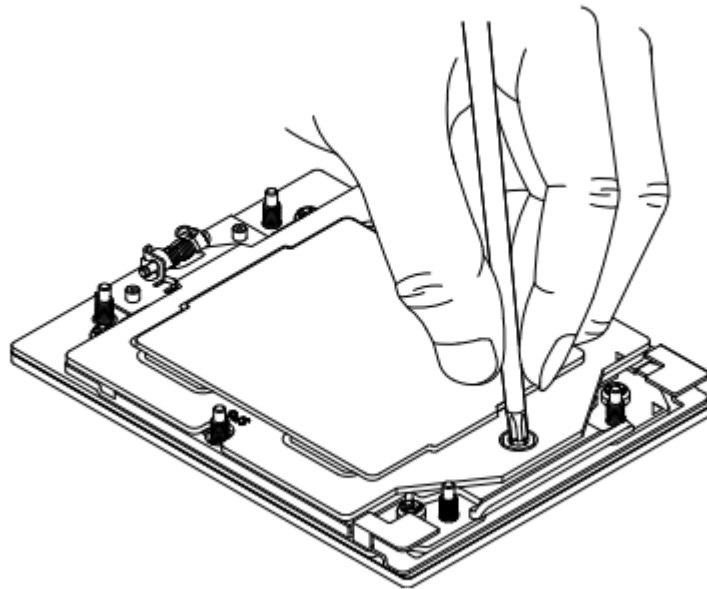

3. Lift the rail frame using the lift tabs near the front end of the rail frame. Note that the rail frame is spring-loaded, so use caution when lifting it up into a vertical position.

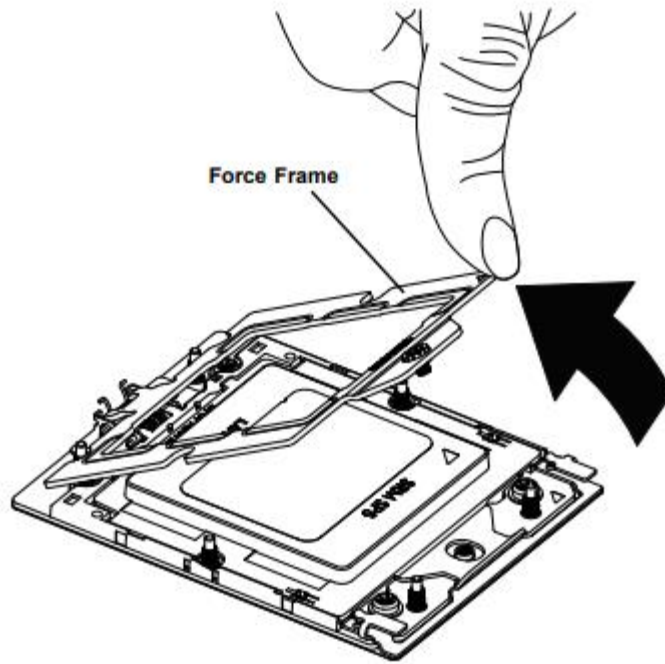

4. Grip the handle of the carrier frame and pull upward to extract it from the rail frame. Return the carrier frame/processor package to its original shipping container.

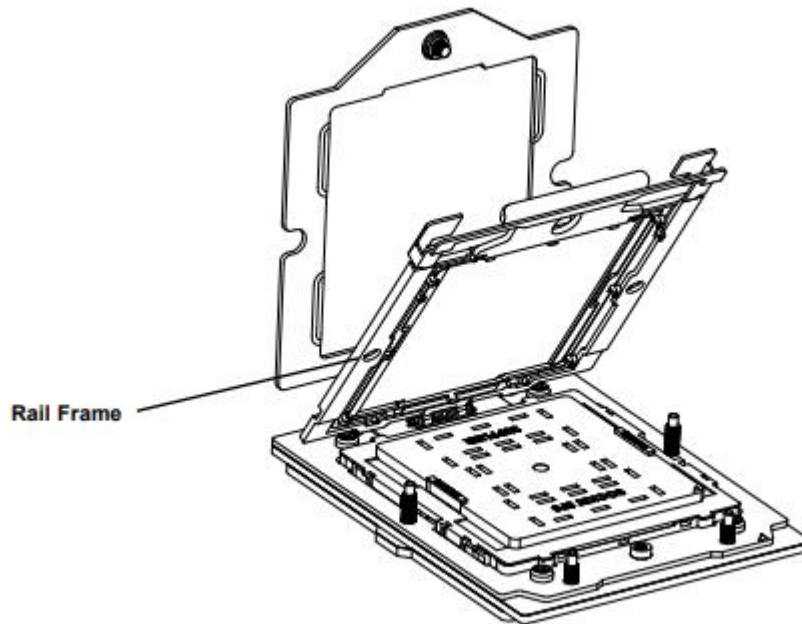

5. Grip the handle on the external cap and return it to the rail frame sliding it downward until it rests in the frame.

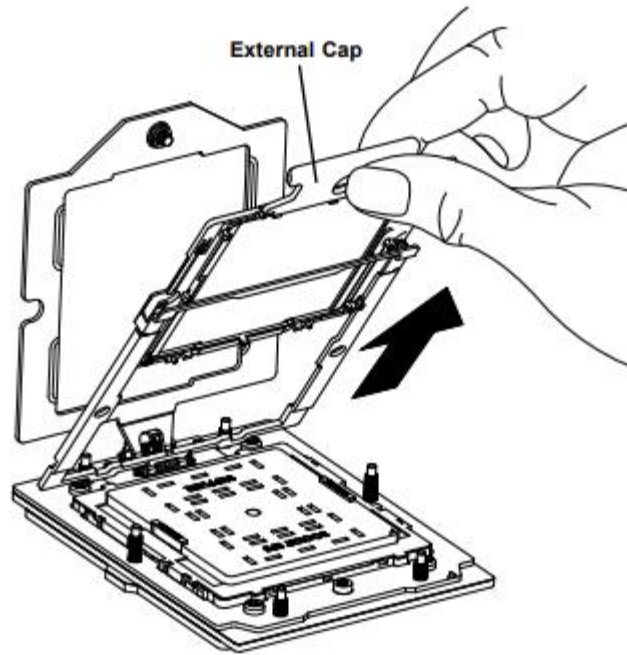

6. Gripping the rail frame, rotate it downward until it rests above and locks over the socket housing horizontally.

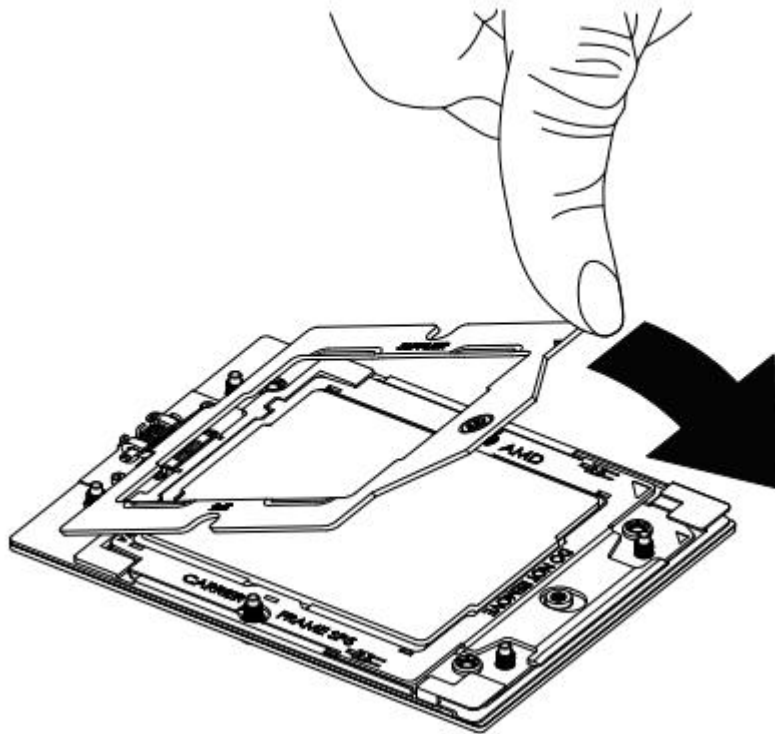

7. Push and rotate the force frame down until it is over the external cap and rail frame horizontally. The force frame is spring-loaded and must be held in place before it is secured.

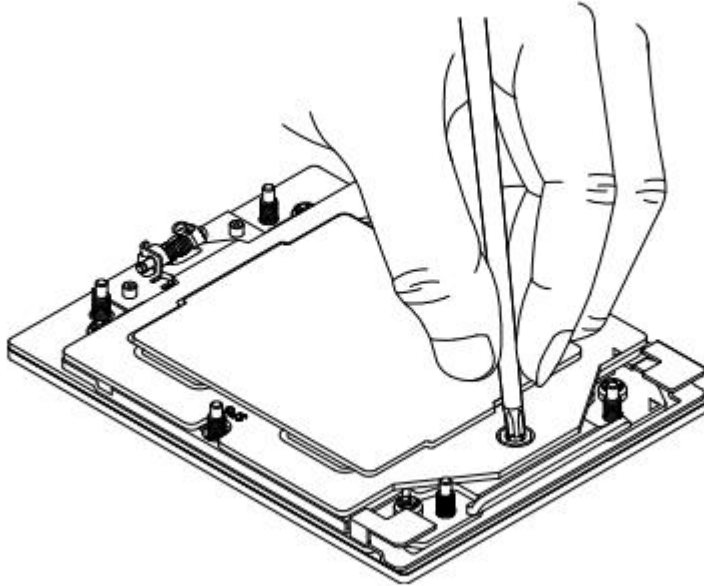

8. While holding down the force frame, secure it back to the socket frame by securing Screw #1 in place.

11. GPU Tray

Type and number of fastenings: Two (2) captive Phillips screws.

Tools required: Screwdriver with PH2 bit.

Procedure: Loosen the two captive Phillips screws from the handle levers, then pull down on both handle levers simultaneously to disengage the GPU tray and pull it out of the chassis.

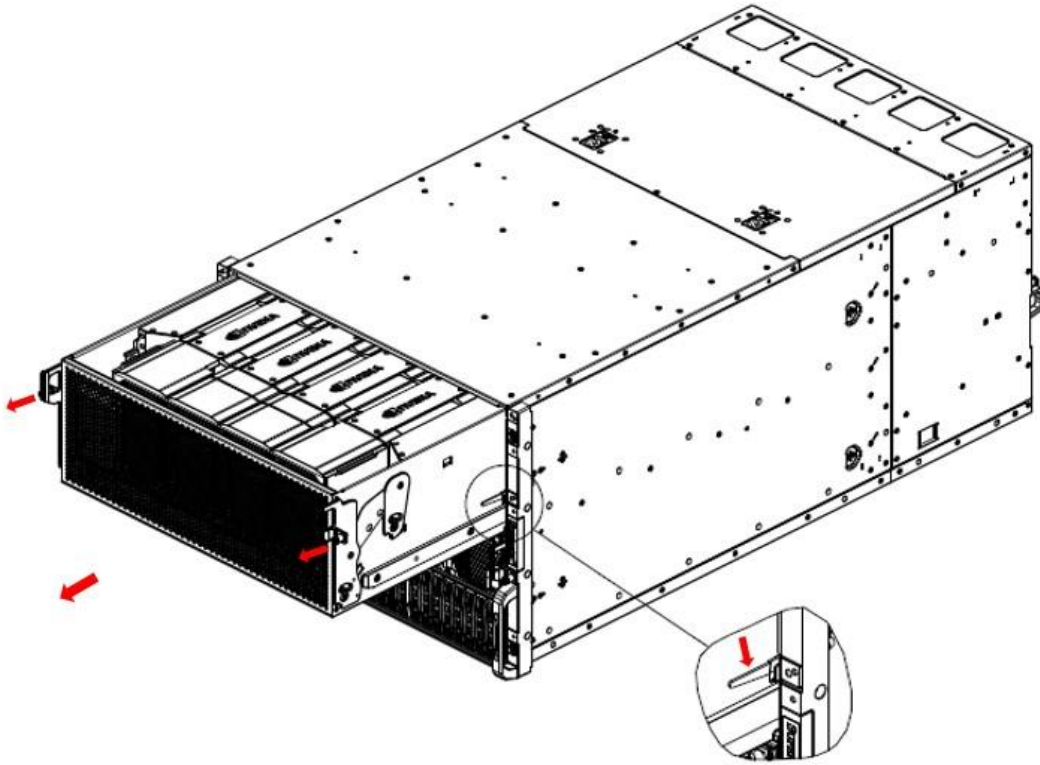

12. GPU

Type and number of fastenings: Two (2) small Phillips screws, two (2) latch levers, 17 Torx T15 screws.

Tools required: Screwdriver with PH2 bit, T15 bit. (8 inch / 200 mm length recommended.)

Procedure:

1. Remove the two small Phillips screws from the structural support bar running across the width of the GPU tray at the top rear.
2. Flip the two latch levers on each metal air blocker to the open position and slide the metal air blocker up along the tray side wall.
3. Extend the two GPU lifting handles fully. Loosen the 17 captive T15 screws.
4. Once the screws have been loosened, lift the GPU up and out of the system.

