



SUPERSERVER[®] SYS-821GV-TNR



USER'S MANUAL

Revision 1.0a

The information in this User's Manual has been carefully reviewed and is believed to be accurate. The vendor assumes no responsibility for any inaccuracies that may be contained in this document, and makes no commitment to update or to keep current the information in this manual, or to notify any person or organization of the updates. Please Note: For the most up-to-date version of this manual, please see our website at www.supermicro.com.

Super Micro Computer, Inc. ("Supermicro") reserves the right to make changes to the product described in this manual at any time and without notice. This product, including software and documentation, is the property of Supermicro and/or its licensors, and is supplied only under a license. Any use or reproduction of this product is not allowed, except as expressly permitted by the terms of said license.

IN NO EVENT WILL Super Micro Computer, Inc. BE LIABLE FOR DIRECT, INDIRECT, SPECIAL, INCIDENTAL, SPECULATIVE OR CONSEQUENTIAL DAMAGES ARISING FROM THE USE OR INABILITY TO USE THIS PRODUCT OR DOCUMENTATION, EVEN IF ADVISED OF THE POSSIBILITY OF SUCH DAMAGES. IN PARTICULAR, SUPER MICRO COMPUTER, INC. SHALL NOT HAVE LIABILITY FOR ANY HARDWARE, SOFTWARE, OR DATA STORED OR USED WITH THE PRODUCT, INCLUDING THE COSTS OF REPAIRING, REPLACING, INTEGRATING, INSTALLING OR RECOVERING SUCH HARDWARE, SOFTWARE, OR DATA.

Any disputes arising between manufacturer and customer shall be governed by the laws of Santa Clara County in the State of California, USA. The State of California, County of Santa Clara shall be the exclusive venue for the resolution of any such disputes. Supermicro's total liability for all claims will not exceed the price paid for the hardware product.

FCC Statement: This equipment has been tested and found to comply with the limits for a Class A or Class B digital device pursuant to Part 15 of the FCC Rules. These limits are designed to provide reasonable protection against harmful interference when the equipment is operated in industrial environment for Class A device or in residential environment for Class B device. This equipment generates, uses, and can radiate radio frequency energy and, if not installed and used in accordance with the manufacturer's instruction manual, may cause harmful interference with radio communications. Operation of this equipment in a residential area is likely to cause harmful interference, in which case you will be required to correct the interference at your own expense.

California Best Management Practices Regulations for Perchlorate Materials: This Perchlorate warning applies only to products containing CR (Manganese Dioxide) Lithium coin cells. Perchlorate Material-special handling may apply. See www.dtsc.ca.gov/hazardouswaste/perchlorate.



WARNING: This product can expose you to chemicals including lead, known to the State of California to cause cancer and birth defects or other reproductive harm. For more information, go to www.P65Warnings.ca.gov.

The products sold by Supermicro are not intended for and will not be used in life support systems, medical equipment, nuclear facilities or systems, aircraft, aircraft devices, aircraft/emergency communication devices or other critical systems whose failure to perform be reasonably expected to result in significant injury or loss of life or catastrophic property damage. Accordingly, Supermicro disclaims any and all liability, and should buyer use or sell such products for use in such ultra-hazardous applications, it does so entirely at its own risk. Furthermore, buyer agrees to fully indemnify, defend and hold Supermicro harmless for and against any and all claims, demands, actions, litigation, and proceedings of any kind arising out of or related to such ultra-hazardous use or sale.

Manual Revision 1.0a

Release Date: October 30, 2023

Unless you request and receive written permission from Super Micro Computer, Inc., you may not copy any part of this document. Information in this document is subject to change without notice. Other products and companies referred to herein are trademarks or registered trademarks of their respective companies or mark holders.

Copyright © 2023 by Super Micro Computer, Inc.
All rights reserved.

Printed in the United States of America

Preface

About this Manual

This manual is written for professional system integrators and PC technicians. It provides information for the installation and use of this server. Installation and maintenance should be performed by experienced technicians only.

Please refer to the SYS-821GV-TNR server specifications [page](#) on our website for updates on supported memory, processors and operating systems (www.supermicro.com).

Notes

For your system to work properly, please follow the links below to download all necessary drivers/utilities and the user's manual for your server.

- Supermicro product manuals: <https://www.supermicro.com/support/manuals/>
- Product drivers and utilities: <https://www.supermicro.com/wdl/>
- Product safety info: <https://www.supermicro.com/en/about/policies/safety-information>

If you have any questions, please contact our support team at: support@supermicro.com

This manual may be periodically updated without notice. Please check the Supermicro website for possible updates to the manual revision level.

Secure Data Deletion

A secure data deletion tool designed to fully erase all data from storage devices can be found on our website: https://www.supermicro.com/about/policies/disclaimer.cfm?url=/wdl/utility/Lot9_Secure_Data_Deletion_Utility/

Warnings

Special attention should be given to the following symbols used in this manual.



Warning! Indicates important information given to prevent equipment/property damage or personal injury.



Warning! Indicates high voltage may be encountered when performing a procedure.

Contents

Chapter 1 Introduction

1.1 Overview.....	9
1.2 System Features	10
Front View	10
Drive Carrier Indicators.....	11
Input/Output Panel.....	11
Control Panel.....	12
Rear View.....	14
Power Supply Indicator.....	15
Fan Module Indicator.....	15
Top View, Motherboard Tray and Switch Module	16
Top View, GPU Tray.....	18
1.3 System Block Diagram.....	19
PCIe Mapping	20
1.4 Motherboard Layout	21
Quick Reference	22
Motherboard Block Diagram	24

Chapter 2 Server Installation

2.1 Overview.....	25
2.2 Unpacking the System	25
2.3 Preparing for Setup	25
Choosing a Setup Location.....	25
Rack Precautions	26
Server Precautions.....	26
Rack Mounting Considerations	26
Ambient Operating Temperature.....	26
Airflow	26
Mechanical Loading.....	27
Circuit Overloading	27
Reliable Ground.....	27
2.4 Installing the Rails	28
2.5 Installing the Server	30

Chapter 3 Maintenance and Component Installation

3.1 Removing Power	31
3.2 Accessing the System.....	31
3.3 Processor and Heatsink.....	36
Processor Overview	36
Installation Overview	37
Installation Procedure Overview.....	37
Create the Processor Carrier Assembly	38
Assemble the Processor Heatsink Module	42
Remove the Socket Cover.....	44
Install the PHM.....	45
Removing the PHM.....	48
Removing the Carrier Assembly from the Heatsink	50
Removing the Processor from the Carrier Assembly	51
3.4 Memory.....	52
Memory Support.....	52
Memory Population Guidelines	54
Guidelines Regarding Mixing DIMMs	54
DIMM Construction	54
Max Series CPUs	54
Installing Memory	55
3.5 Motherboard Battery.....	56
3.6 Storage Drives.....	57
Installing Hot-Swap Drives.....	57
M.2 Drives	59
Checking the Temperature of an NVMe Drive.....	60
3.7 System Cooling	61
Changing a System Fan	61
Motherboard Air Shroud.....	62
3.8 Power Supply	63
Power Supply LEDs	63
3.9 PCIe Expansion Cards.....	65
Installing Expansion Cards (1–8).....	66
Installing Riser Expansion Cards (9–12)	67

Chapter 4 Motherboard Connections

4.1 Rear Connectors	69
4.2 Power Connections	69
4.3 Headers and Connectors	70
4.4 Jumpers	72
4.5 LED Indicators	73

Chapter 5 Software

5.1 Driver Installation.....	75
5.2 SuperDoctor® 5.....	76
5.3 BMC.....	77
BMC ADMIN User Password	77

Chapter 6 Optional Components

6.1 Power Supply Modules	78
6.2 NIC Kit	78

Chapter 7 Troubleshooting and Support

7.1 Information Resources	79
Website	79
Direct Links for the SYS-821GV-TNR System	79
Direct Links for General Support and Information	79
7.2 BMC Interface	80
7.3 Troubleshooting Procedures	81
General Technique	81
No Power	81
No Video	81
System Boot Failure	82
Memory Errors	82
Losing the System Setup Configuration	82
When the System Becomes Unstable	82
7.4 BIOS Error Beep (POST) Codes	84
Additional BIOS POST Codes	84
7.5 Crash Dump Using the BMC Dashboard.....	85
7.6 UEFI BIOS Recovery	86
Overview	86
Recovering the UEFI BIOS Image.....	86
Recovering the Main BIOS Block with a USB Device.....	86
7.7 CMOS Clear	91

7.8 BMC Reset.....91

7.9 Where to Get Replacement Components92

7.10 Reporting an Issue.....92

 Technical Support Procedures92

 Returning Merchandise for Service.....92

 Vendor Support Filing System93

7.11 Feedback.....93

7.12 Contacting Supermicro.....94

Appendix A Standardized Warning Statements for AC Systems

Appendix B System Specifications

Contacting Supermicro

Headquarters

Address: Super Micro Computer, Inc.
980 Rock Ave.
San Jose, CA 95131 U.S.A.

Tel: +1 (408) 503-8000

Fax: +1 (408) 503-8008

Email: marketing@supermicro.com (General Information)
Sales-USA@supermicro.com (Sales Inquiries)
Government_Sales-USA@supermicro.com (Gov. Sales Inquiries)
support@supermicro.com (Technical Support)
RMA@supermicro.com (RMA Support)
Webmaster@supermicro.com (Webmaster)

Website: www.supermicro.com

Europe

Address: Super Micro Computer B.V.
Het Sterrenbeeld 28, 5215 ML
's-Hertogenbosch, The Netherlands

Tel: +31 (0) 73-6400390

Fax: +31 (0) 73-6416525

Email: Sales_Europe@supermicro.com (Sales Inquiries)
Support_Europe@supermicro.com (Technical Support)
RMA_Europe@supermicro.com (RMA Support)

Website: www.supermicro.nl

Asia-Pacific

Address: Super Micro Computer, Inc.
3F, No. 150, Jian 1st Rd.
Zhonghe Dist., New Taipei City 235
Taiwan (R.O.C)

Tel: +886-(2) 8226-3990

Fax: +886-(2) 8226-3992

Email: Sales-Asia@supermicro.com.tw (Sales Inquiries)
Support@supermicro.com.tw (Technical Support)
RMA@supermicro.com.tw (RMA Support)

Website: www.supermicro.com.tw

Chapter 1

Introduction

1.1 Overview

This chapter provides an outline of the functions and features of the SuperServer SYS-821GV-TNR. This GPU system supports the Intel PVC OAM. The following provides an overview of the specifications and capabilities.

System Overview	
Motherboard	X13DEG-PVC
Chassis	CSE-GP801TS
Processors	Supports dual 4th Gen Intel Xeon Scalable processors, in Socket E (LGA4677) with four UPIs (16 GT/s max.) and a thermal design power (TDP) of up to 350 W. Supports SP XCC, SP MCC, and Max Series (HBM) SKUs.
Memory	Up to 8 TB 3DS RDIMM/RDIMM DDR5 ECC memory with speeds up to 4800 MT/s (1PDC) or 4400 MT/s (2DPC) in 32 DIMM slots
GPUs	Intel OAM 1.0 PVC, PCIe 5.0 x16 CPU-to-GPU Interconnect, XeLink GPU-to-GPU interconnect
Storage	Nineteen 2.5" hot-swap front drive bays: sixteen NVMe and three SATA (four of the NVMe drives require an optional NIC kit) Two M.2 NVMe SSDs
Expansion Slots	Twelve PCIe 5.0 slots (see Section 3.9 for details)
I/O Ports	One RJ45 dedicated BMC LAN port Two USB 3.0 ports; one VGA port
System Cooling	Eighteen heavy duty fans with speed control, including fans as part of the power modules GPU air blockers, motherboard air shrouds
Power	Six redundant power supplies (3 + 3 redundancy); 3000 W (per power supply), 80Plus Titanium level
Form Factor	8U; 17.2" x 14" x 33.2" (WxHxD) (43.7 x 35.6 x 84.3 cm)

A Quick Reference Guide can be found on the [product page](#) of the Supermicro website.

The following safety models associated with the SYS-821GV-TNR have been certified as compliant with UL and CSA: GP801-Q30X13, GP801-GPU, GP801-30.

1.2 System Features

The following views of the system display the main features. Refer to [Appendix B](#) for additional specifications.

Front View

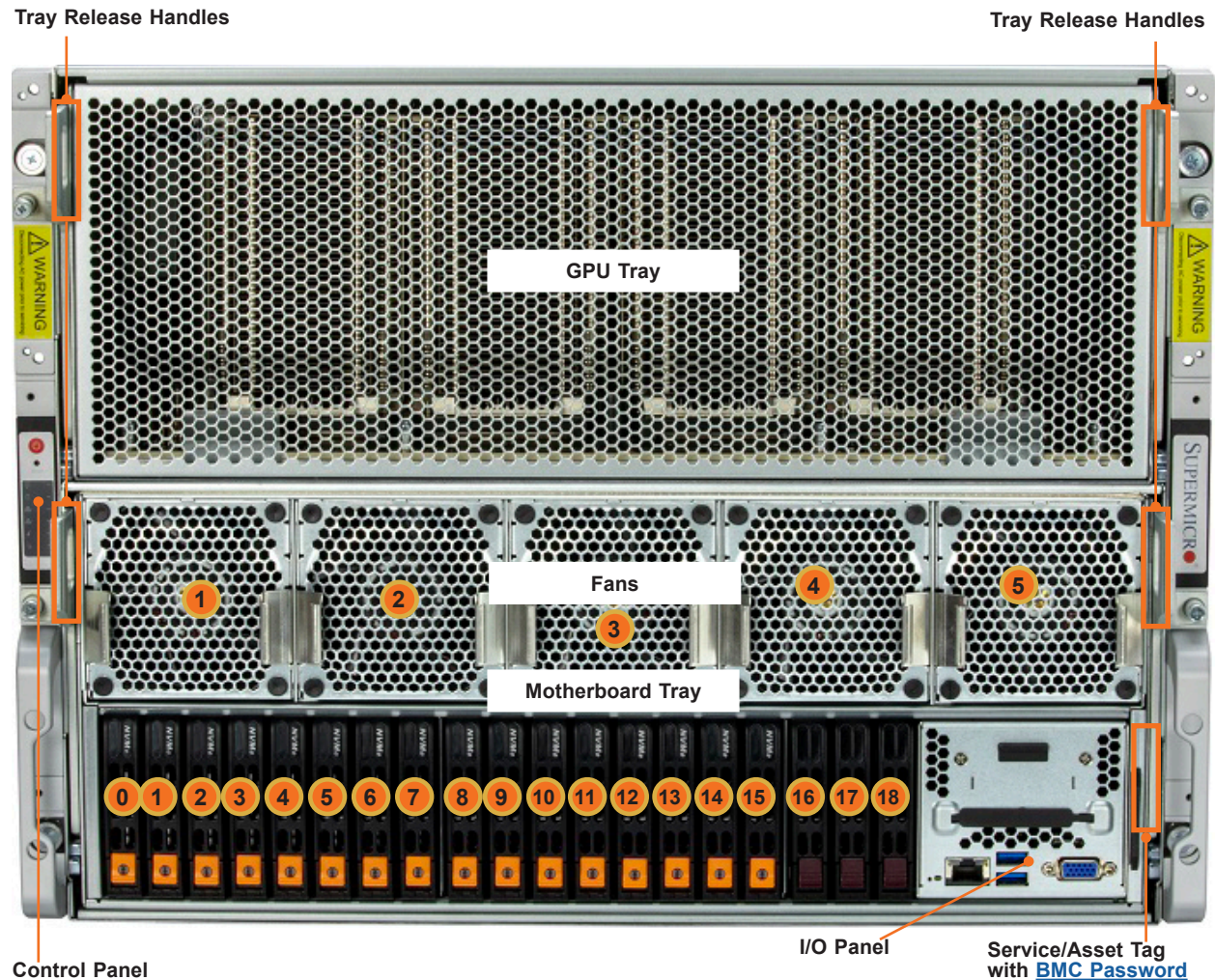

Figure 1-1. Front View

Logical Storage Drive Numbers	
Item	Description
0 to 15	Sixteen 2.5-inch hot-swap NVMe drive bays
16 to 18	Three 2.5-inch hot-swap SATA drive bays

Drive Carrier Indicators

Each drive carrier has two LED indicators: an activity indicator and a status indicator. For RAID configurations using a controller, the meaning of the status indicator is described in the table below. For OS RAID or non-RAID configurations, some LED indications are not supported, such as hot spare.

Drive Carrier LED Indicators			
	Color	Blinking Pattern	Behavior for Device
Activity LED	Blue	Solid On	Idle SAS/NVMe drive installed
	Blue	Blinking	I/O activity
	Off		Idle SATA drive installed
Status LED	Red	Solid On	Failure of drive with RSTe support
	Red	Blinking at 1 Hz	Rebuild drive with RSTe support
	Red	Blinking with two blinks and one stop at 1 Hz	Hot spare for drive with RSTe support
	Red	On for five seconds, then off	Power on for drive with RSTe support
	Red	Blinking at 4 Hz	Identify drive with RSTe support
	Green	Solid on	Safe to remove NVMe drive
	Amber	Blinking at 1Hz	Do not remove NVMe drive

Input/Output Panel

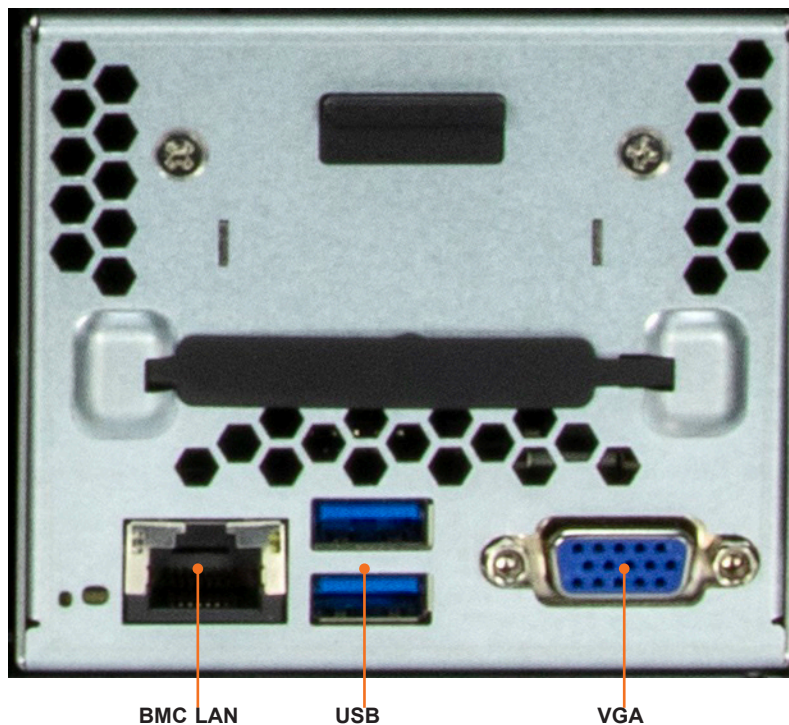

Figure 1-2. Input/Output Panel

Control Panel

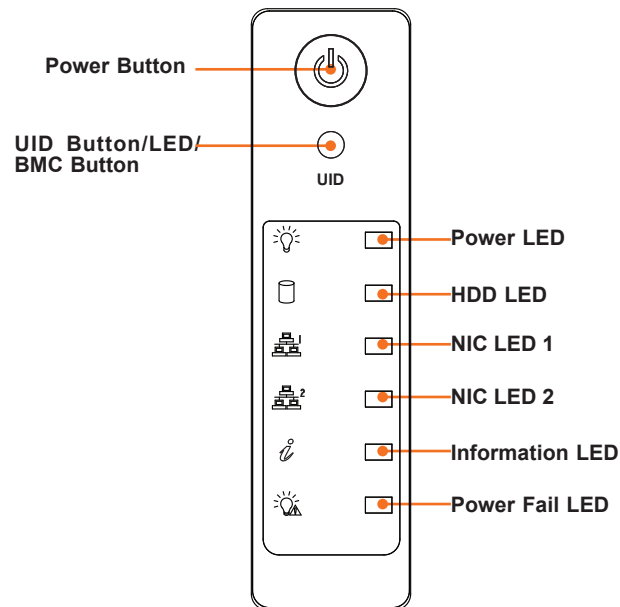

Figure 1-3. Control Panel

Control Panel Features	
Features	Description
Power Button	The main power switch applies or removes primary power from the power supply to the server but maintains standby power.
UID button/LED/BMC button	The unit identification (UID) button turns on or off the blue light function of the Information LED and a blue LED on the rear of the chassis. This button can also be used to reset the BMC .
Power LED	Steady on – Power on Blinking at 4 Hz – Checking BIOS/BMC integrity Blinking at 4 Hz and "i" LED is blue – BIOS firmware updating Two blinks at 4 Hz, one pause 2hz and "i" LED blue – BMC firmware updating Blinking at 1 Hz and "i" LED red – Fault detected
HDD LED	Indicates activity on the storage drives when flashing.
NIC LEDs	Non-functional, as there are no onboard network connections.
Information LED	Alerts operator to several states (noted in the table below).
Power Fail LED	Indicates a power supply module has failed.

Information LED	
Color, Status	Description
Red, solid	An overheating condition has occurred
Red, blinking at 1 Hz	Fan failure, check for an inoperative fan
Red, blinking at 0.25 Hz	Power failure, check for a non-operational power supply
Red, blinking at 10 Hz	CPLD recovery mode error

(Table continued on next page)

Information LED	
Color, Status	Description
Blue, solid	Unit ID has been activated by switch
Blue, blinking at 1 Hz	Unit ID has been activated using the BMC
Blue, blinking at 2 Hz, and BMC Heartbeat LED on the motherboard is green	BMC is resetting
Blue, blinking at 4 Hz	BMC is setting factory defaults
Blue, blinking at 10 Hz	BIOS/BMC is recovering or updating
Red, blinking at 10 Hz and the rear UID LED is blue, blinking at 10 Hz	CPLD recovery or update is in progress

Front Control Panel LED Indicators						
Event	Power	HDD	NIC	UID	Info	Power Fail
Power On	Solid On					
HDD Activity		Blinking				
NIC Activity			Blinking			
Overheat					Solid On	
Fan Fail					Blinking 1Hz	
Power Fail					Blinking 1/4Hz	Solid On
Local UID On				Solid On		
Remote UID On				Blinking 1Hz		
Checking BMC/BIOS	Blinking at 4HZ					
Recovering/Updating	BMC Blinking at 4HZ BMC 2 Blinks at 4Hz, 1 Pause at 2Hz (on-on-off-off)			BIOS/BMC Blinking @10Hz		
Flash Not Detected or Golden Image Check Failed	BMC/BIOS Blinking at 1HZ					
CPLD Recovery Mode				Blinking @10Hz (MB UID LED)	Blinking at 10Hz (FP Red LED)	

Rear View

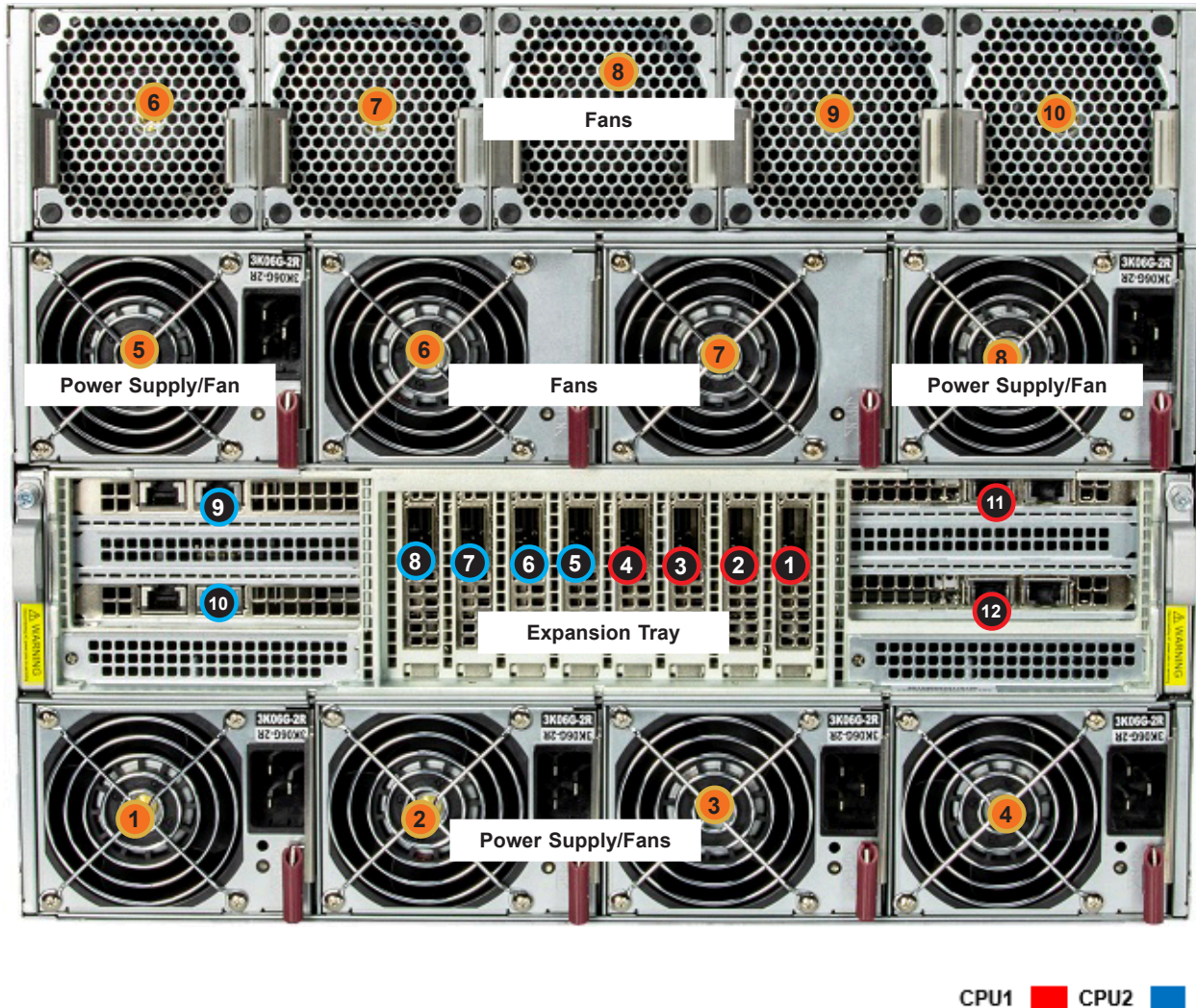

Figure 1-4. System: Rear View

System Features: Rear	
Feature	Description
Fans	Seven exhaust fans, showing logical numbering
Power Supply/Fans	Six combination power supply modules with system cooling fans, showing logical numbering
PCIe Slots	Twelve slots for PCIe expansion cards, showing logical numbering

Expansion Slot Locations	
Slot	Description
1	PCIe 5.0 x16 (LP) from PLX switch to GPUs
2	PCIe 5.0 x16 (LP) from PLX switch to GPUs
3	PCIe 5.0 x16 (LP) from PLX switch to GPUs
4	PCIe 5.0 x16 (LP) from PLX switch to GPUs
5	PCIe 5.0 x16 (LP) from PLX switch to GPUs
6	PCIe 5.0 x16 (LP) from PLX switch to GPUs
7	PCIe 5.0 x16 (LP) from PLX switch to GPUs
8	PCIe 5.0 x16 (LP) from PLX switch to GPUs
9	PCIe 5.0 x16 (FHFL) (requires an optional NIC kit)
10	PCIe 5.0 x16 (FHFL) (requires an optional NIC kit)
11	PCIe 5.0 x16 (FHFL)
12	PCIe 5.0 x16 (FHFL)

Power Supply Indicator

Power Supply Indicator	
LED Color and State	Power Supply Condition
Solid Green	Indicates that the power supply is on
Blinking Green	Indicates that the power supply is plugged in and turned off by the system.
Blinking Amber	Indicates that the power supply has a warning condition and continues to operate.
Solid Amber	Indicates that the power supply is plugged in, and is in an abnormal state. The system might need service. Please contact Supermicro technical support.
Off	No AC power to modules

Fan Module Indicator

Fan Module Indicator	
LED Color and State	Condition
Solid Green	Indicates that the fan is on and working
Solid Amber	Indicates failure or needs attention
Solid Red	Indicates that the fan is receiving standby power
Off	Indicates the fan is off

Top View, Motherboard Tray and Switch Module

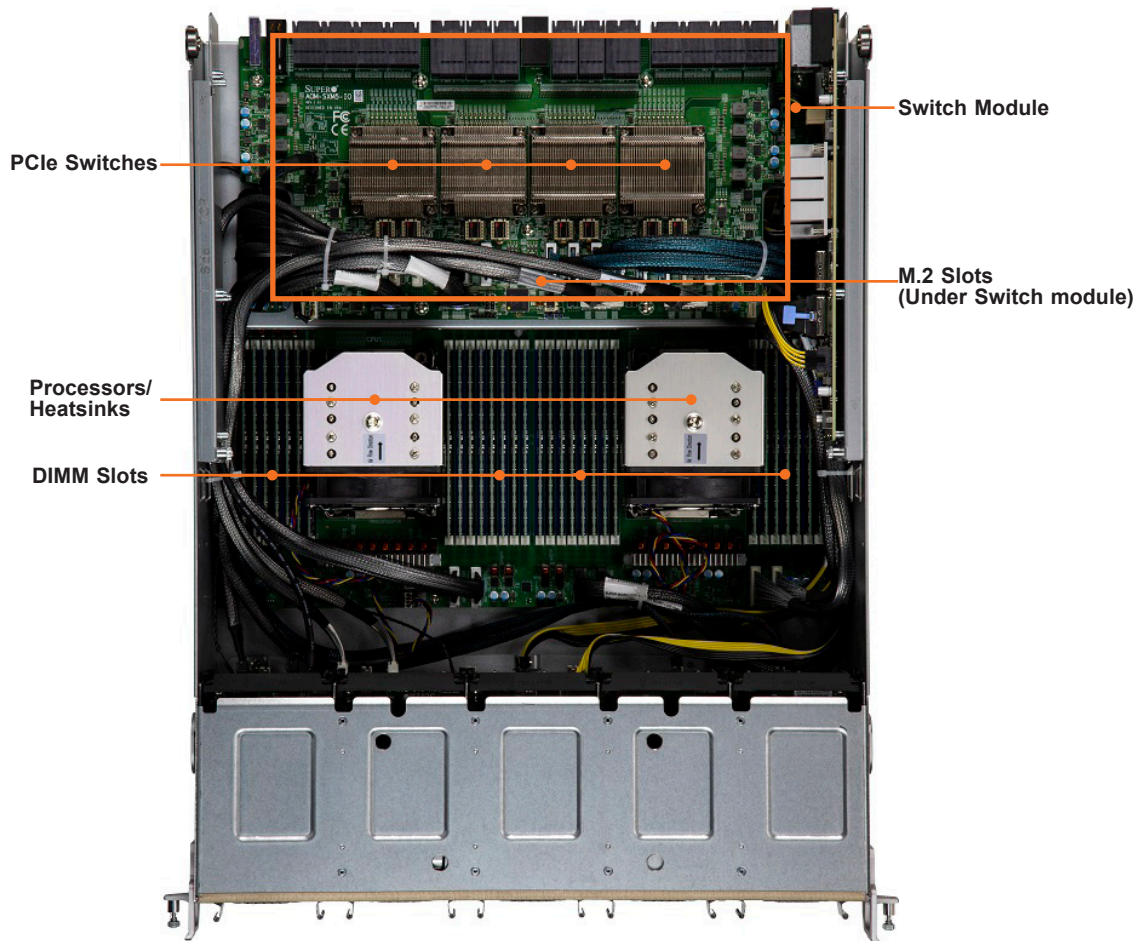

Figure 1-5. Motherboard Tray: Top View

Motherboard Tray Features	
Feature	Description
Switch Module	Platform for switches and I/O
PCIe Switches	Four switches to facilitate direct communication between GPUs
M.2 Slots	Two slots for PCIe 3.0 x2 M.2 NVMe
Processors	Dual 4th Gen Intel Xeon Scalable with active heatsinks
DIMM Slots	Thirty-two memory slots

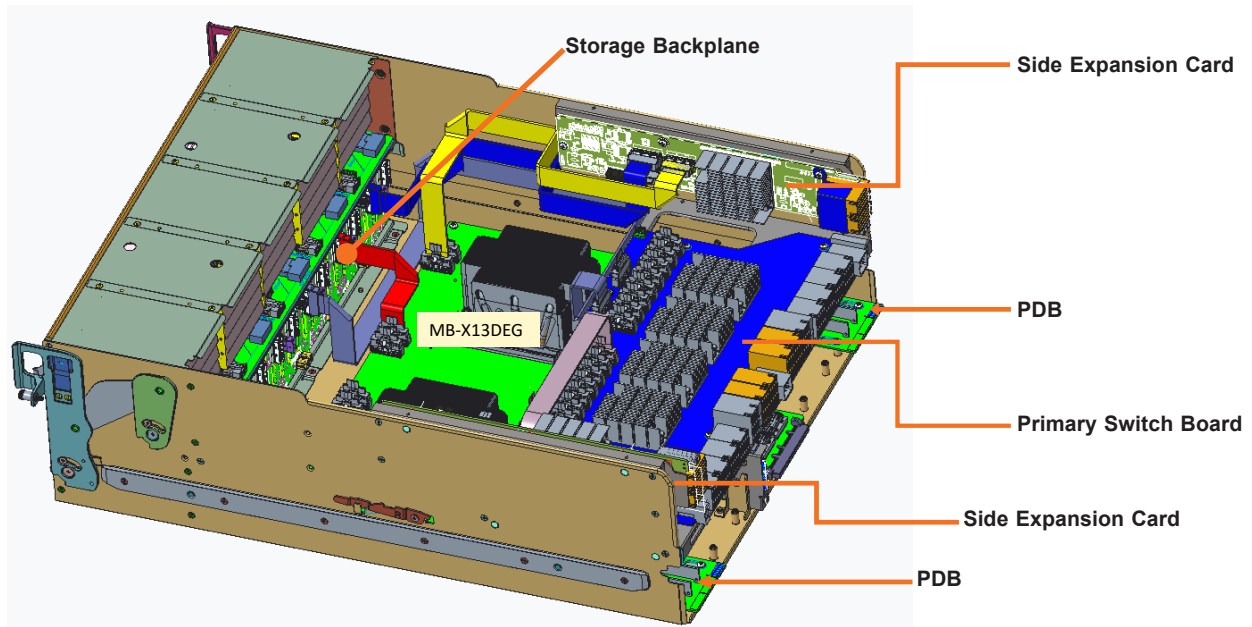

Figure 1-6. Motherboard Tray: Components

Motherboard Tray Features	
Feature	Description
Side Expansion Card(s)	Add-on modules with PLX switch to facilitate front NVMe and rear PCIe NIC riser board. The default configuration includes one card.
Primary Switch Board	PCIe Gen5 switch board
Storage Backplane	Twenty-four slot direct-attached backplane
PDBs	Two power distribution boards (extension board)

Top View, GPU Tray

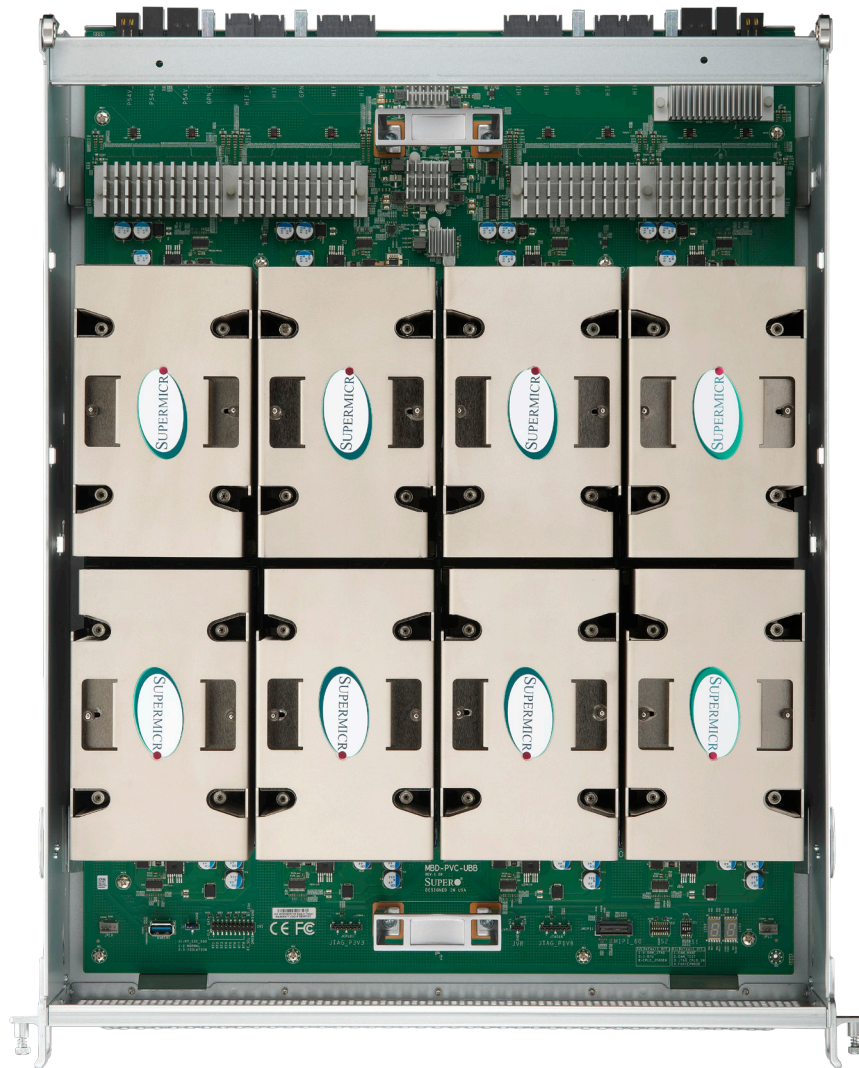

Figure 1-7. Intel PVC Max Series 1550 8-GPU: Top View

1.3 System Block Diagram

The block diagram below shows the connections and relationships between the subsystems and major components of the overall system.

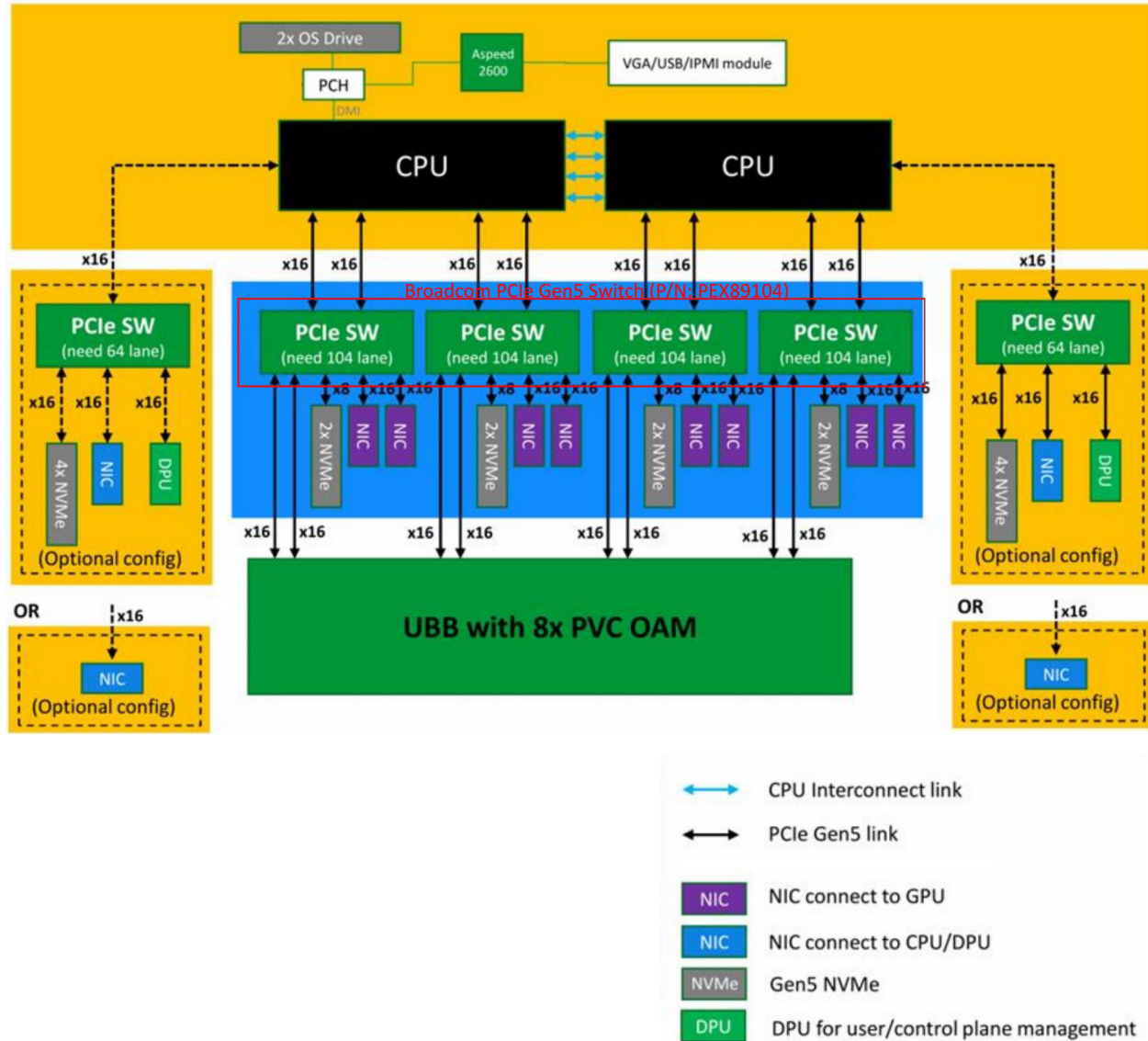

Figure 1-8. System Block Diagram

PCIe Mapping

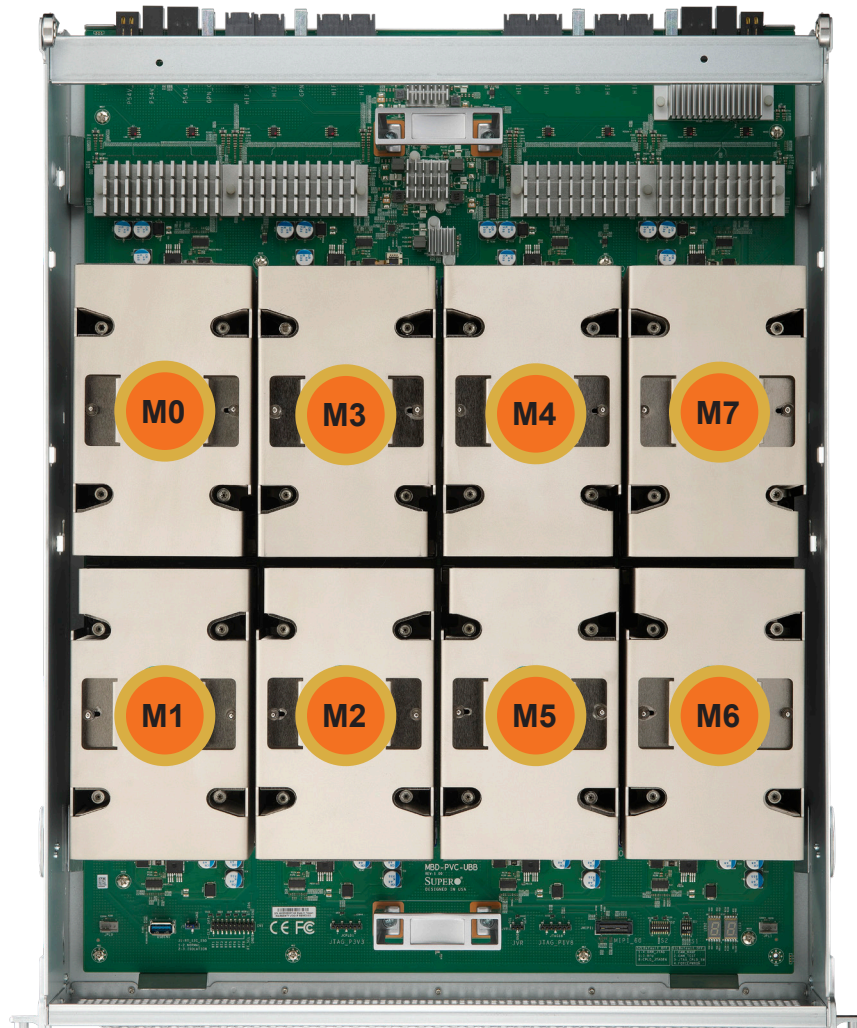

Figure 1-9. UBB Mapping

UBB PCIe Mapping Table		
Linux OS Numbering	Physical Location	PCIe Bus ID
Numbering changes with every system boot	M0	2c:00:00
	M1	1a:00:00
	M2	5f:00:00
	M3	3c:00:00
	M4	ad:00:00
	M5	9c:00:00
	M6	dd:00:00
	M7	bc:00:00

1.4 Motherboard Layout

Below is a layout of the X13DEG-PVC motherboard with jumper, connector and LED locations shown. See the table on the following page for descriptions. For detailed descriptions, pinout information and jumper settings, refer to [Chapter 4](#) or the [Motherboard Manual](#).

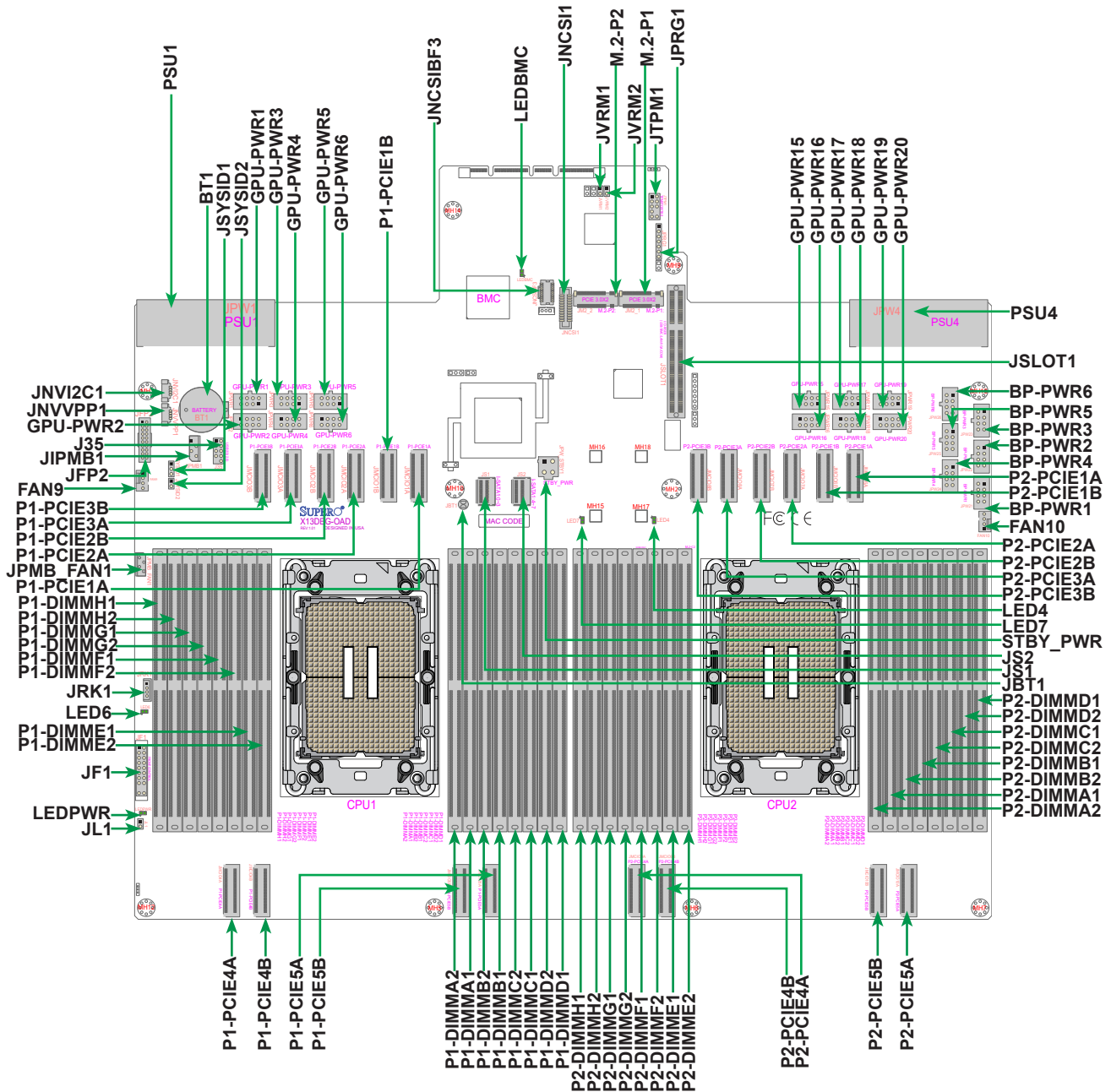

Figure 1-10. Motherboard Layout

Quick Reference

Jumper	Description	Default Setting
JBT1	CMOS Clear	Open (Normal)
JVRM1 JVRM2	BMC and PCH I ² C/SDA to VRM or BMC and PCH I ² C/SCL to VRM Select	Pins 1/3 BMC I ² C/SDA for VRM (Default); Pins 3/5 PCH I ² C/SDA for VRM, Pins 2/4: BMC I ² C/SCL for VRM (Default); Pins 4/6: PCH I ² C/SCL for VRM support

Connector	Description
Battery (BT1)	Onboard battery
BP-PWR1–3 (JPW21–JPW23)	12V 8-pin power connector
FAN9–FAN10, JPMB_FAN1	4-pin CPU heatsink fan headers; JPMB_FAN1 is not used in this system
J35 (USB2/3)	USB 2.0 header (supports up to two USB connections)
JF1	Front Control Panel header with I ² C (not used in this system)
JFP2	Front Control Panel header with USB and VGA (not used in this system)
GPU-PWR1–20 (JPWR1– JPWR20)	12V 8-pin power connectors
JIPMB1	6-pin BMC external I2C header
JL1	Chassis Intrusion header
JNCSI1	NC-SI (Network Controller Sideband Interface) connector
JNCSIBF3	BF-3 card NC-SI (Network Controller Sideband Interface) connector
JNVI2C1	Header for NVMe I2C
JNVVPP1	Header for VPP I2C
JPRG1	Connector reserved for manufacturer use for onboard CPLD (Complex Programmable Logic Device) firmware programming
JRK1	Not used in this system
JTPM1	Trusted Platform Module/Port 80 connector
JSLOT1	Used for I/O board which provides: dedicated BMC LAN, two USB 3.0 ports, VGA header, COM header, and dual 1G or 10G (redundant only) ports
JS1 (I-SATA 0-3)	SlimSAS LP (MCIO) connector with support for eight Intel PCH SATA 3.0 connections (RAID 0, RAID 1, RAID 5, and RAID 10 supported)
JS2 (I-SATA 4-7)	SlimSAS LP (MCIO) connector with support for eight Intel PCH SATA 3.0 connections (RAID 0, RAID 1, RAID 5, and RAID 10 supported)
JSYSID1	System SKU Identifier Header
JSYSID2	System SKU Identifier Header
M.2-P1 (JM2_1)/M.2-P2 (JM2_2)	PCIe 3.0 x2 M.2 slots (with support of M-Key 2280, and 22110)
MH1–MH14	Mounting holes for screws used to attach the motherboard to the chassis
MH15 – MH18	Mounting holes for M.2 SSDs
P1-PCIE3B (JMCIO3B)	PCIe 5.0 x8 MCIO connector connected to CPU1
P1-PCIE3A (JMCIO3A)	PCIe 5.0 x8 MCIO connector connected to CPU1
P1-PCIE2B (JMCIO2B)	PCIe 5.0 x8 MCIO connector connected to CPU1
P1-PCIE2A (JMCIO2A)	PCIe 5.0 x8 MCIO connector connected to CPU1
P1-PCIE1B (JMCIO1B)	PCIe 5.0 x8 MCIO connector connected to CPU1
P1-PCIE1A (JMCIO1A)	PCIe 5.0 x8 MCIO connector connected to CPU1
P2-PCIE3B (JMCIO8B)	PCIe 5.0 x8 MCIO connector connected to CPU2

Connector	Description
P2-PCIE3A (JMCIO8A)	PCIe 5.0 x8 MCIO connector connected to CPU2
P2-PCIE2A (JMCIO7A)	PCIe 5.0 x8 MCIO connector connected to CPU2
P2-PCIE2A (JMCIO7A)	PCIe 5.0 x8 MCIO connector connected to CPU2
P2-PCIE1B (JMCIO6B)	PCIe 5.0 x8 MCIO connector connected to CPU2
P2-PCIE1A (JMCIO6A)	PCIe 5.0 x8 MCIO connector connected to CPU2
P1-PCIE4A (JMCIO4A)	PCIe 5.0 x8 MCIO connector connected to CPU1
P1-PCIE4B (JMCIO4B)	PCIe 5.0 x8 MCIO connector connected to CPU1
P1-PCIE5A (JMCIO5A)	PCIe 5.0 x8 MCIO connector connected to CPU1
P1-PCIE5B (JMCIO5A)	PCIe 5.0 x8 MCIO connector connected to CPU1
P2-PCIE4A (JMCIO9A)	PCIe 5.0 x8 MCIO connector connected to CPU2
P2-PCIE4B (JMCIO9B)	PCIe 5.0 x8 MCIO connector connected to CPU2
P2-PCIE5A (JMCIO10A)	PCIe 5.0 x8 MCIO connector connected to CPU2
P2-PCIE5B (JMCIO10B)	PCIe 5.0 x8 MCIO connector connected to CPU2
PSU1, 4 (JPW1, JPW4)	Power supply connectors for system power
STBY_PWR (JPW_STBY1)	Standby power connector

LED	Description	State: Status
LED6 (UID-LED)	Unit Identifier (UID) LED	Solid Blue: Unit Identified
LED4, LED7	M.2 Activity LED	Blinking Green: Device Working
LEDBMC	BMC Heartbeat LED	Blinking Green: BMC Normal (Active), Solid Green: (During BMC Reset or during a Cold Reboot)
LEDPWR	Power LED	LED On: Onboard Power On

Motherboard Block Diagram

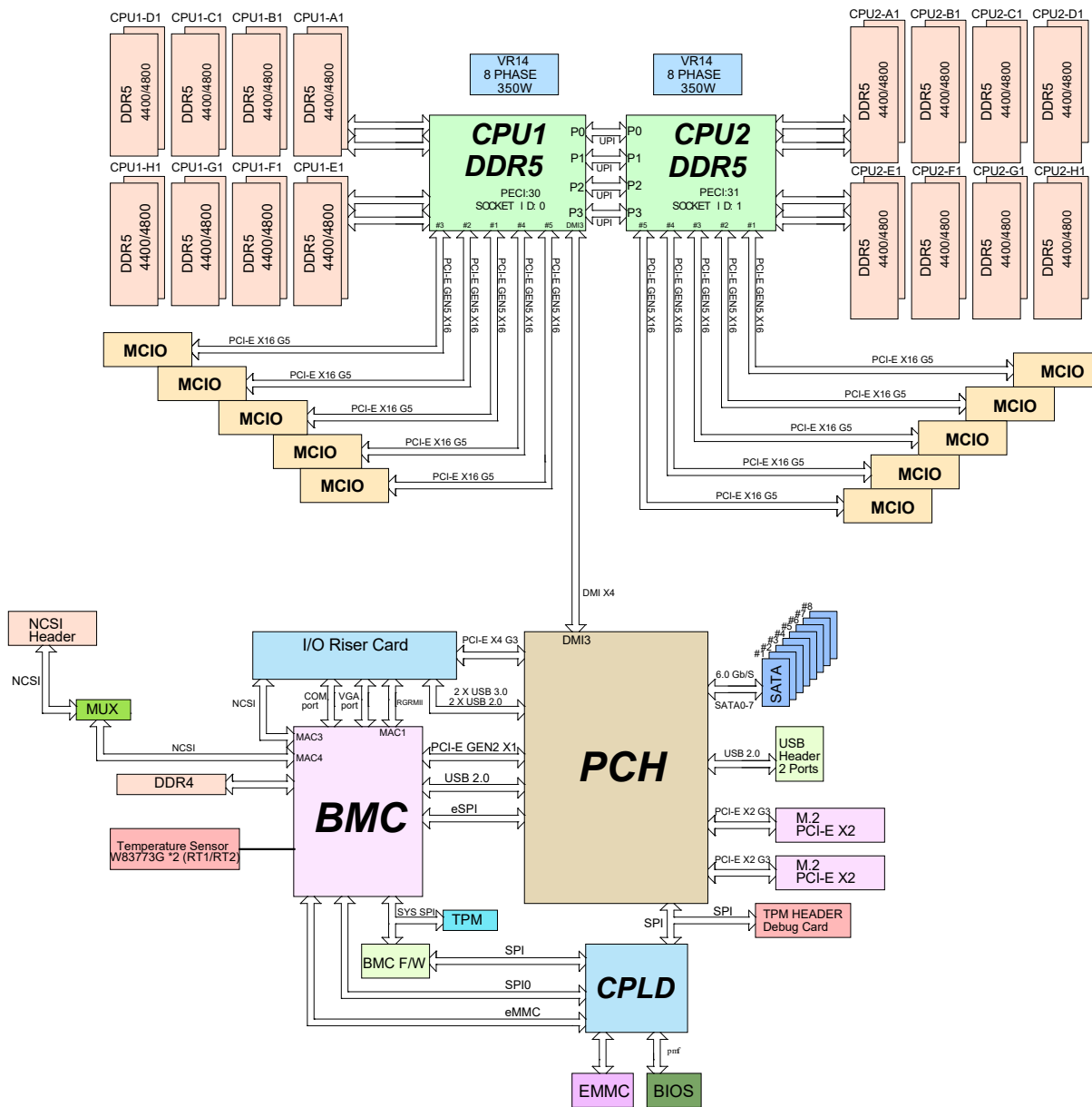

Figure 1-11. Motherboard Block Diagram

Chapter 2

Server Installation

2.1 Overview

This chapter provides advice and instructions for mounting your system in a server rack. If your system is not already fully integrated with processors, system memory, etc., refer to [Chapter 3](#) for details on installing those specific components.

Caution: Electrostatic Discharge (ESD) can damage electronic components. To prevent such damage to PCBs (printed circuit boards), it is important to use a grounded wrist strap, handle all PCBs by their edges and keep them in anti-static bags when not in use.

2.2 Unpacking the System

Inspect the box in which the SuperServer was shipped, and note if it was damaged in any way. If any equipment appears damaged, file a damage claim with the carrier who delivered it.

Decide on a suitable location for the rack unit that will hold the server. It should be situated in a clean, dust-free area that is well ventilated. Avoid areas where heat, electrical noise and electromagnetic fields are generated. It will also require a grounded AC power outlet nearby. Be sure to read the precautions and considerations noted in [Appendix A](#).

2.3 Preparing for Setup

The box in which the system was shipped should include the rackmount hardware needed to install it into the rack. Please read this section in its entirety before you begin the installation.

Choosing a Setup Location

- The system should be situated in a clean, dust-free area that is well ventilated. Avoid areas where heat, electrical noise and electromagnetic fields are generated.
- Leave enough clearance in front of the rack so that you can open the front door completely (~25 inches) and approximately 30 inches of clearance in the back of the rack to allow sufficient space for airflow and access when servicing.
- This product should be installed only in a Restricted Access Location (dedicated equipment rooms, service closets, etc.).
- This product is not suitable for use with visual display workplace devices according to §2 of the German Ordinance for Work with Visual Display Units.

Rack Precautions

- Ensure that the leveling jacks on the bottom of the rack are extended to the floor so that the full weight of the rack rests on them.
- In single rack installations, stabilizers should be attached to the rack. In multiple rack installations, the racks should be coupled together.
- Always make sure the rack is stable before extending a server or other component from the rack.
- You should extend only one server or component at a time. Extending two or more simultaneously may cause the rack to become unstable.

Server Precautions

- Review the electrical and general safety precautions in [Appendix A](#).
- Determine the placement of each component in the rack *before* you install the rails.
- Install the heaviest server components at the bottom of the rack first and then work your way up.
- Use a regulating uninterruptible power supply (UPS) to protect the server from power surges and voltage spikes and to keep your system operating in case of a power failure.
- Allow any drives and power supply modules to cool before touching them.
- When not servicing, always keep the front door of the rack and all covers/panels on the servers closed to maintain proper cooling.

Rack Mounting Considerations

Ambient Operating Temperature

If installed in a closed or multi-unit rack assembly, the ambient operating temperature of the rack environment may be greater than the room's ambient temperature. Therefore, consideration should be given to installing the equipment in an environment compatible with the manufacturer's maximum rated ambient temperature (TMRA).

Airflow

Equipment should be mounted into a rack so that the amount of airflow required for safe operation is not compromised.

Mechanical Loading

Equipment should be mounted into a rack so that a hazardous condition does not arise due to uneven mechanical loading.

Circuit Overloading

Consideration should be given to the connection of the equipment to the power supply circuitry and the effect that any possible overloading of circuits might have on overcurrent protection and power supply wiring. Appropriate consideration of equipment nameplate ratings should be used when addressing this concern.

Reliable Ground

A reliable ground must be maintained at all times. To ensure this, the rack itself should be grounded. Particular attention should be given to power supply connections other than the direct connections to the branch circuit (i.e. the use of power strips, etc.).



Warning! To prevent bodily injury when mounting or servicing this unit in a rack, you must take special precautions to ensure that the system remains stable. The following guidelines are provided to ensure your safety:

- This unit should be mounted at the bottom of the rack if it is the only unit in the rack.
- When mounting this unit in a partially filled rack, load the rack from the bottom to the top with the heaviest component at the bottom of the rack.
- If the rack is provided with stabilizing devices, install the stabilizers before mounting or servicing the unit in the rack.
- Slide rail mounted equipment is not to be used as a shelf or a work space.

2.4 Installing the Rails

There are a variety of rack units on the market, which may require a slightly different assembly procedure. Also refer to the installation instructions that came with the rack.

This rail set fits a rack between 28" and 33.5" deep. Do not use a two post "telco" type rack.

1. Identify the left rail set and right rail set, as they are different.
2. Position the template at the front of the system to determine the locations of the screws for the rails.

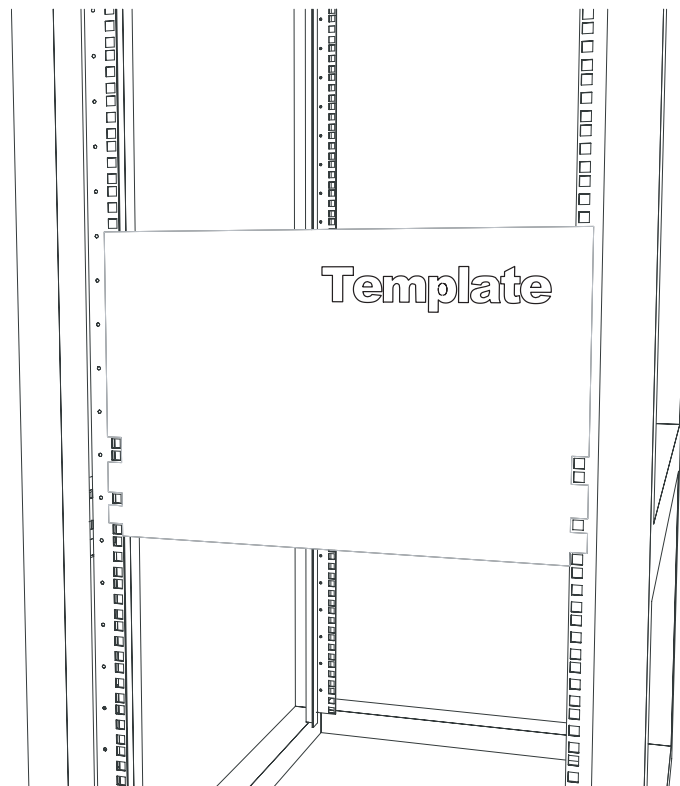

Figure 2-1. Placing the Template

3. In each rail set, the two sections are screwed together to keep them immobile during shipping. Release these screws just enough to allow the rail sections to slide apart. Note the arrow on the rail, which indicates the end that attaches to the front of the rack.
4. Slide the rails sections apart to match the depth of the rack. Position the rails with the template and secure the front of each to the front of the rack with two flathead screws, then secure the back of each rail to the rear of the rack with two flathead screws (see Figure 2-2).
5. Tighten the screws that keep the two rail sections from sliding.

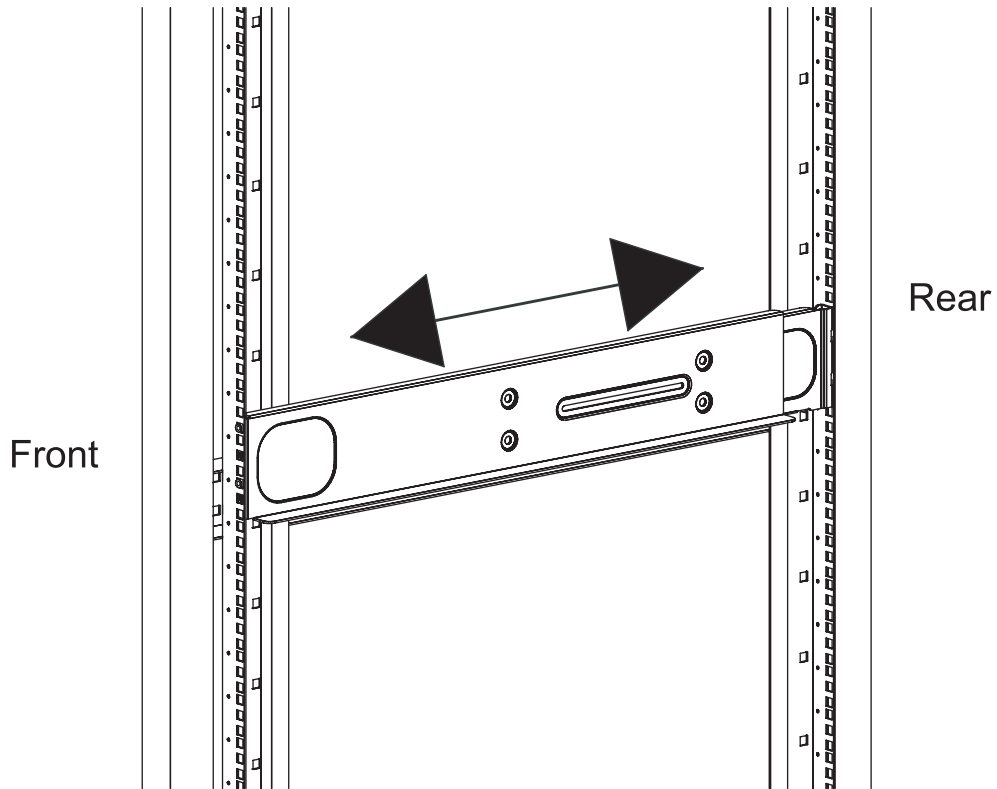

Figure 2-2. Installing the Left Rail

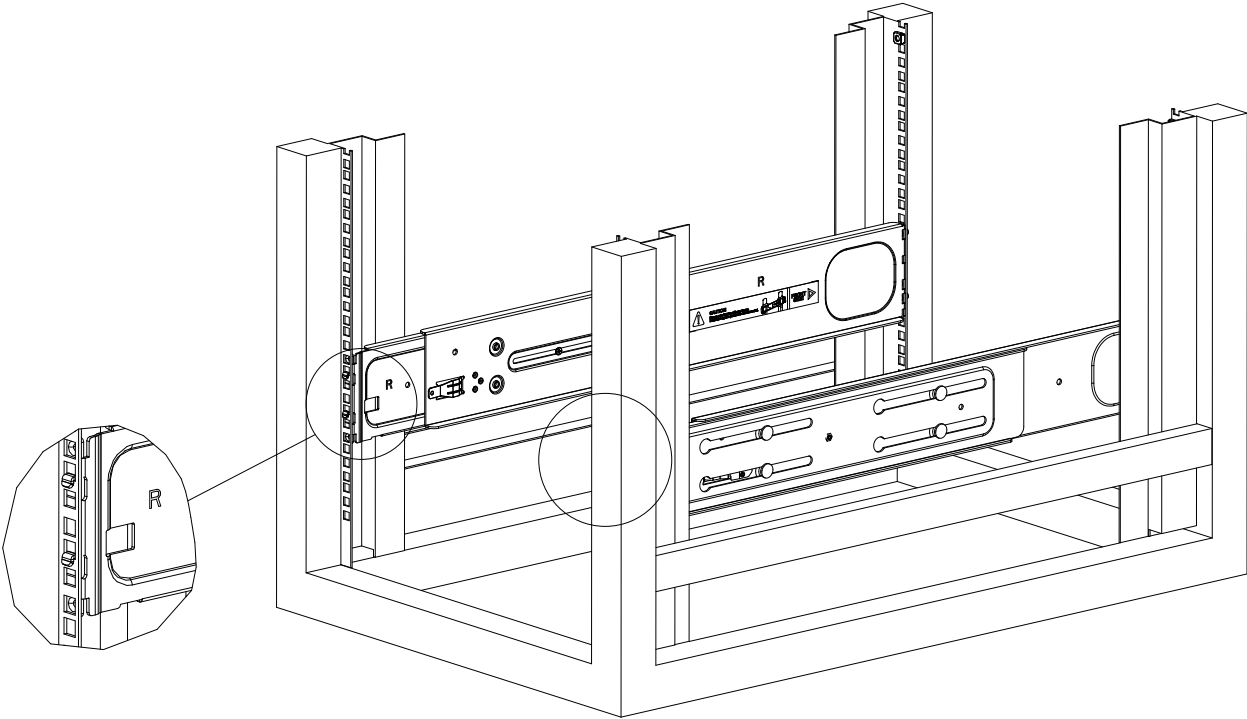

Figure 2-3. Outer Rails Installed on the Rack

2.5 Installing the Server

Caution: The assembled system is quite heavy. Use a lift and multiple people to move it.

1. Using a lift and as many people as necessary, lift the system and slide it onto the installed rails.
2. After pushing the enclosure all the way into the rack, use the thumbscrew on each side of the server to lock it into place.

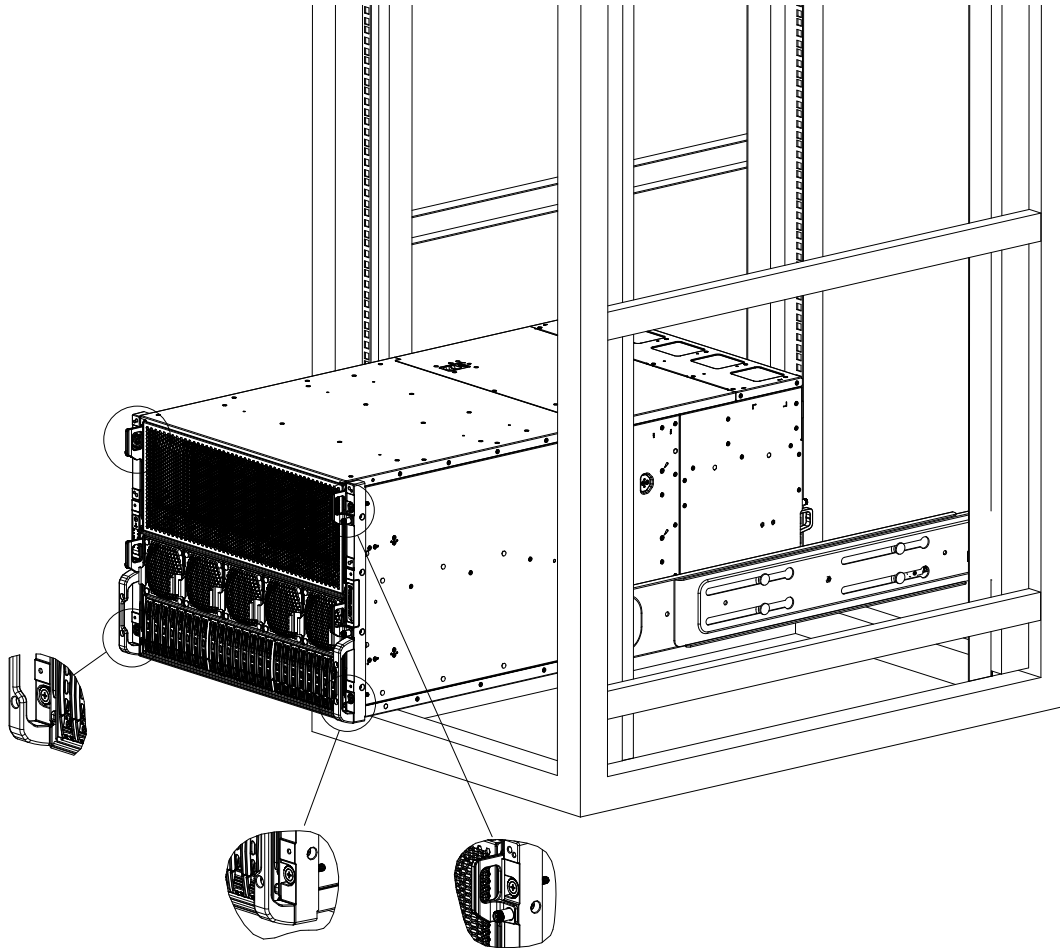

Figure 2-4. Installing the Server onto the Rails

Chapter 3

Maintenance and Component Installation

This chapter provides instructions on installing and replacing main system components. To prevent compatibility issues, only use components that match the specifications and/or part numbers given.

Installation or replacement of most components require that power first be removed from the system. Please follow the procedures given in each section.

3.1 Removing Power

Use the following procedure to ensure that power has been removed from the system. This step is necessary when removing or installing non hot-swap components.

1. Use the operating system to power down the system.
2. After the system has completely shut-down, disconnect the AC power cords from the power strip or outlet. Note that a complete shut-down means that all power supply fans have stopped spinning. It is highly recommended to allow the chassis fans to also spin down to allow for heat dissipation.
3. Disconnect the power cords from the power supply modules.

3.2 Accessing the System

The system is comprised of several trays. Each tray can be removed from the chassis using release levers. Before removing the trays, power down, as described in [Section 3.1](#).

To replace the trays, be sure the primary handles start in the pulled down position. Once the tray is fully inserted, lift and close the handles to lock the tray in place.

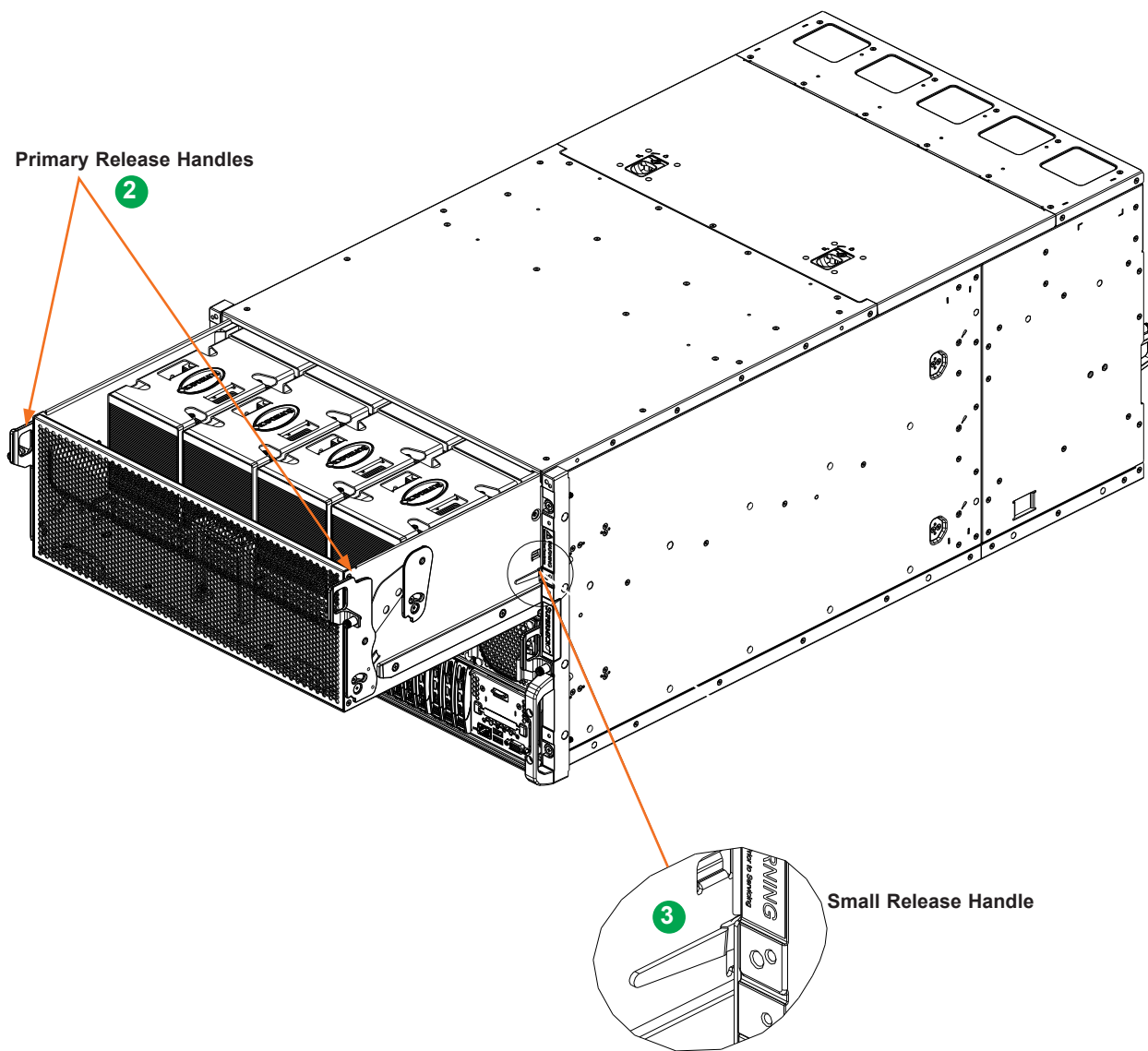

Figure 3-1. Chassis Front, Removing the GPU Tray



Warning: The tray is heavy (70 lbs). Use a lift or multiple people to install or remove it.

Removing the GPU Tray

1. Power down as described in [Section 3.1](#).
2. Pull down the release handles on each side of the tray, and pull the tray part way out.
3. To fully release the tray, find and depress the the small handles on each side of the tray.

Caution: The mid-plane connectors on the rear of the tray are not capable of supporting the weight of the tray. Once the tray is removed from the system, be careful not to lift or tilt the tray so that the connectors are stressed. See the following instructions.

Lift the GPU tray using the sides, as marked below. Do not lift using the handles or the connectors.

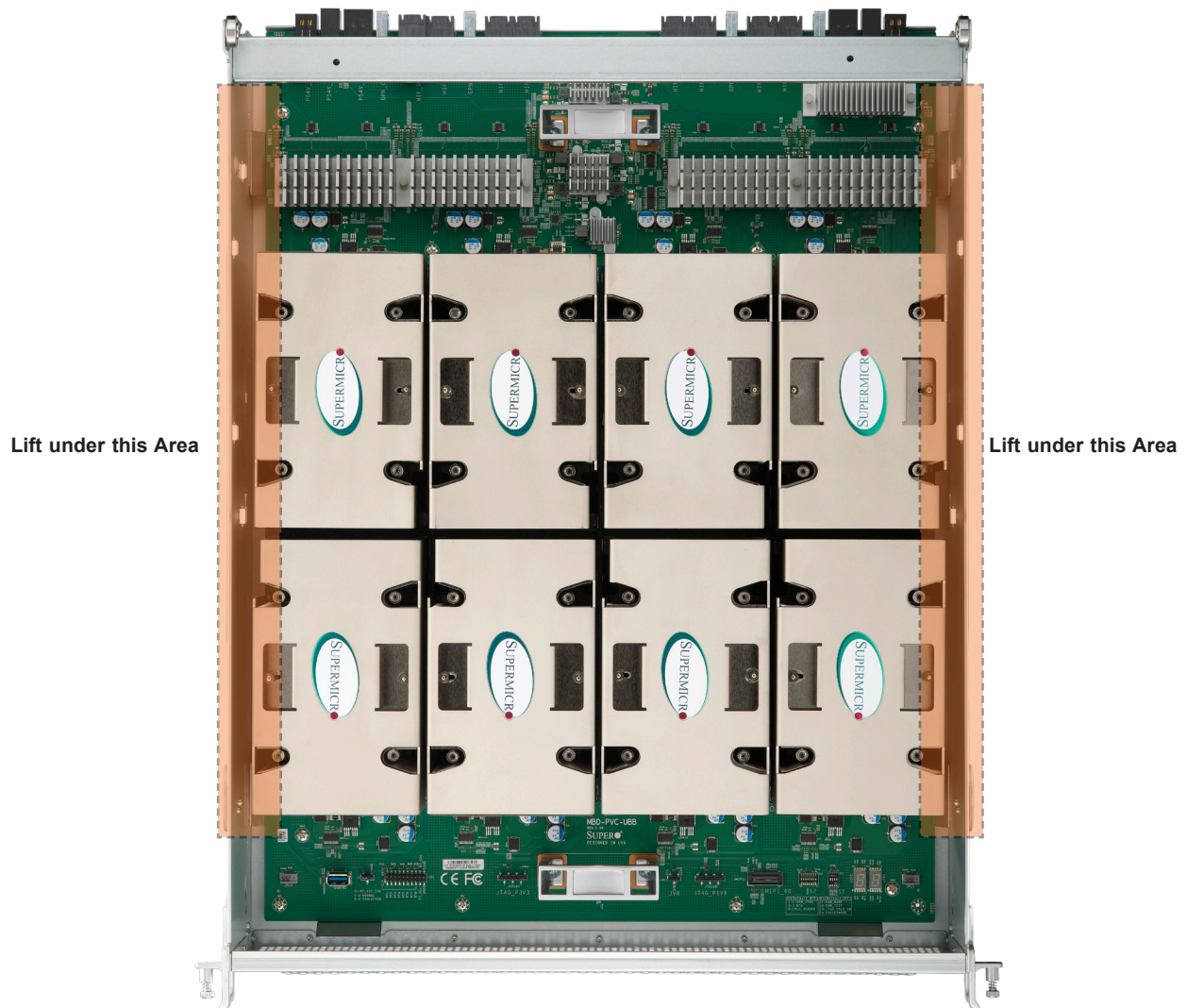

Figure 3-2. Lifting the GPU Tray

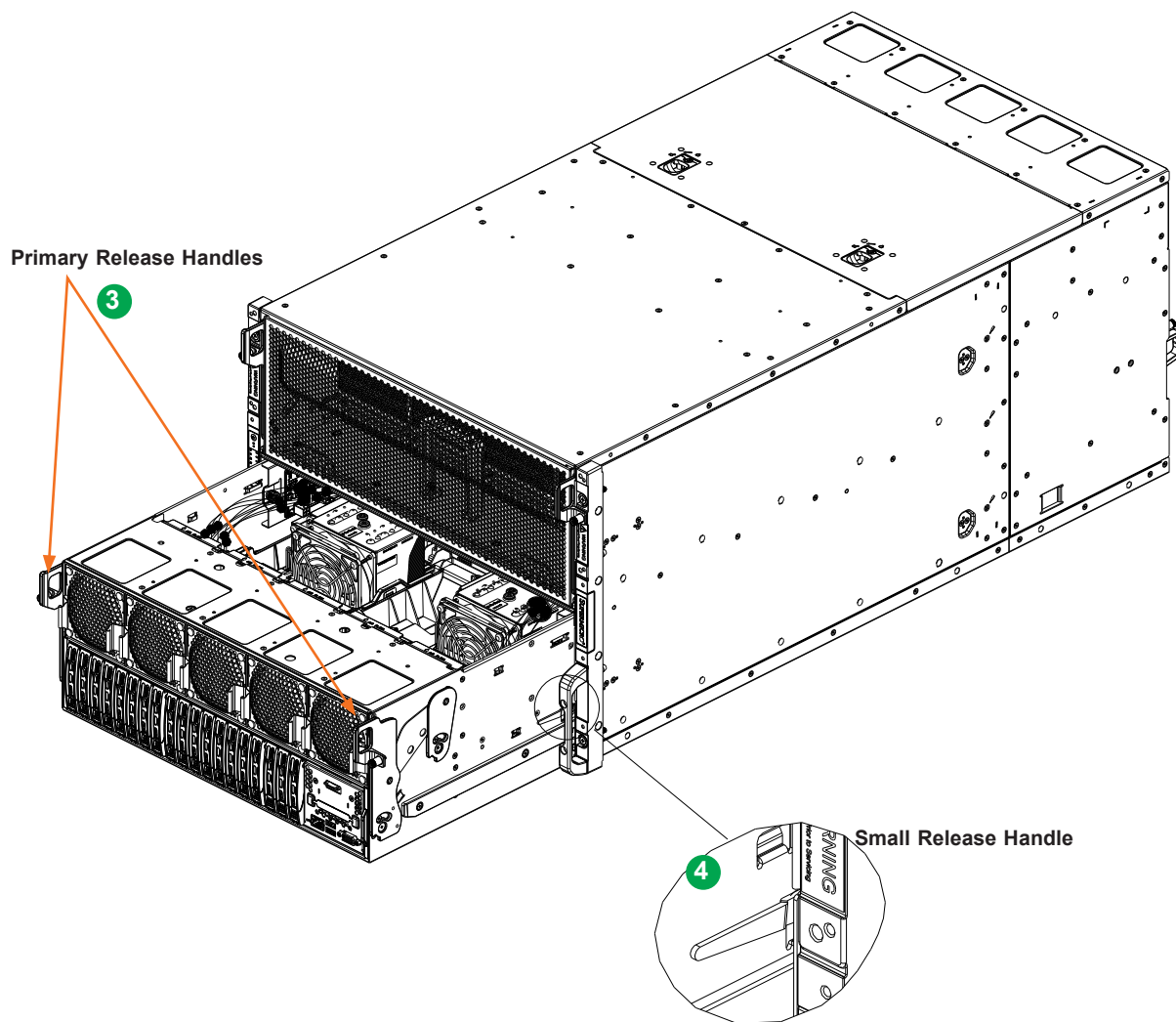

Figure 3-3. Chassis Front, Removing the Motherboard Tray

Removing the Motherboard Tray

1. Power down as described in [Section 3.1](#).
2. Remove rear PCIe tray. (see the next page)
3. Pull down the release handles on each side of the tray, and pull the tray part way out.
4. To fully release the tray, find and depress the the small handles on the side of each tray.

Replacing the Motherboard Tray

1. Be sure the primary handles start in the pulled down position. Once the tray is fully inserted, lift and close the handles to lock the tray in place.
2. Re-insert rear PCIe tray.

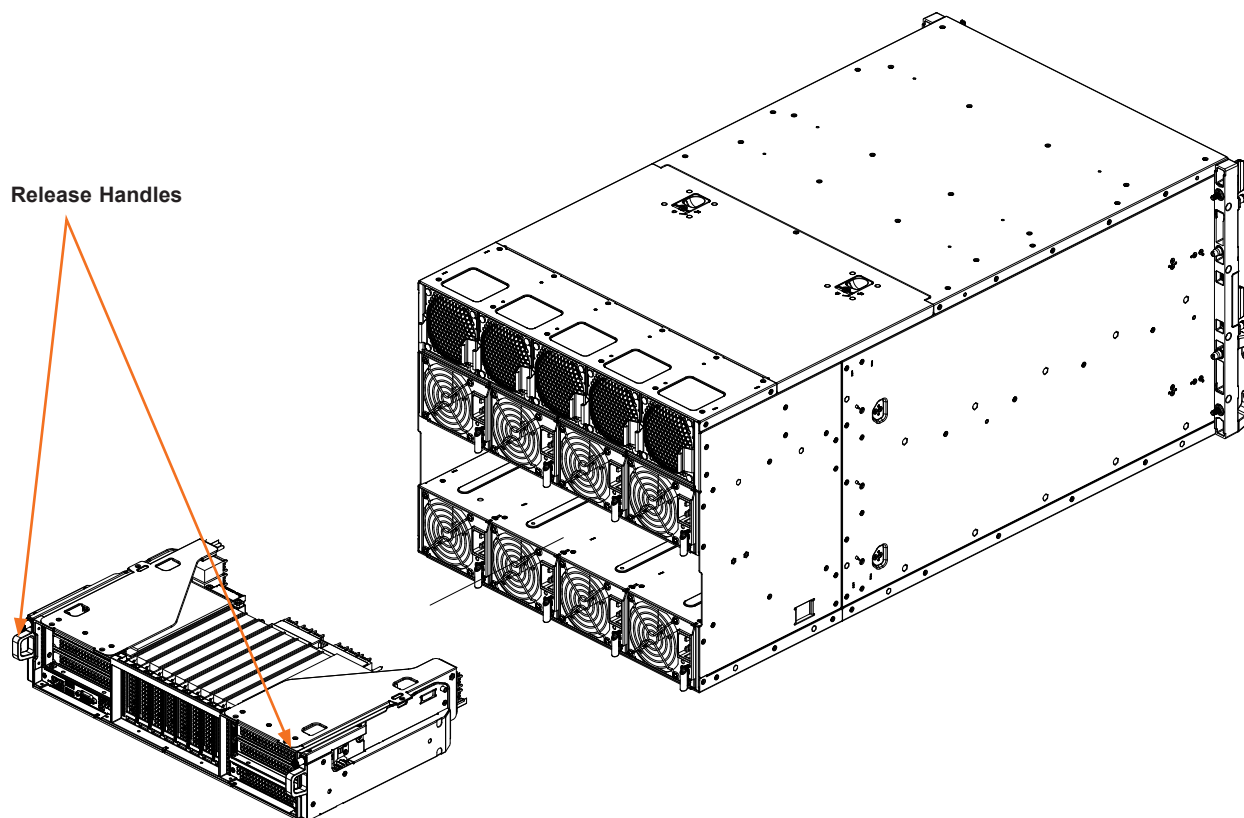

Figure 3-4. Chassis Rear, Removing the PCIe Expansion Tray

Removing the PCIe Expansion Tray

1. Power down as described in [Section 3.1](#).
2. Pull down the release handles on each side of the tray, and pull the tray out.

Note: When replacing trays, insert the front motherboard tray before the PCIe tray.

3.3 Processor and Heatsink

Processor Overview

The motherboard supports three versions of the 4th Gen Intel Xeon Scalable processors. They differ in the number of cores, and each requires a different CPU carrier. The XCC version supports up to 60 cores, the MCC version supports up to 32 cores, and the Max Series (HBM) version supports up to 56 cores. The CPU carriers differ by the presence or absence of shims and levers.

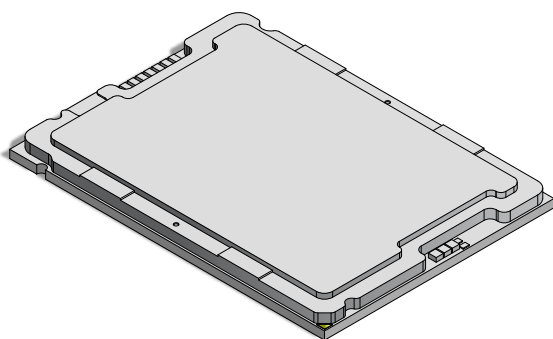

XCC

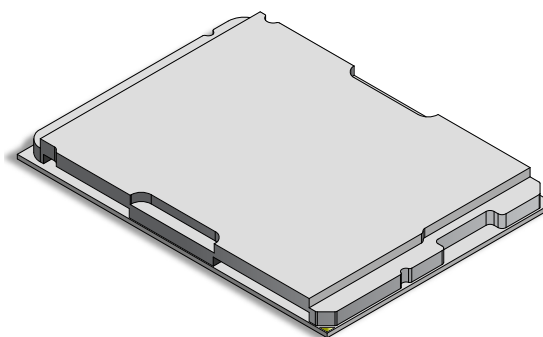

MCC

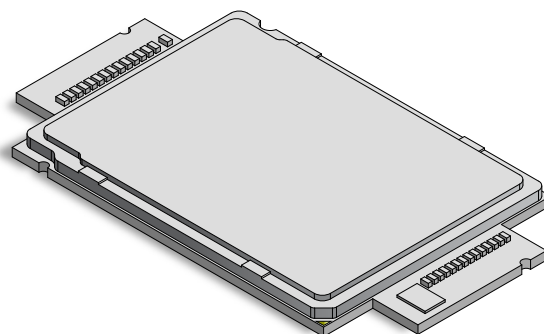

Max

CPU and Carrier Type					
CPU Type	Cores	Carrier Type	Lever	Shim	Carrier Part Number
XCC	60	E1A	Yes	No	SKT-1333L-0000-FXC (alt: SKT-1333L-0001-LTS)
MCC	32	E1B	Yes	Yes	SKT-1424L-001B-FXC (alt: SKT-1424L-001B-LTS)
Max	56	E1C	No	No	SKT-1425H-001C-FXC (alt: SKT-1425H-001C-LTS)

Installation Overview

The processor (CPU) and processor carrier should be assembled together first to form the processor carrier assembly. This will be attached to the heatsink to form the processor heatsink module (PHM) before being installed onto the CPU socket.

Notes:

- Use ESD protection.
- The system power cords must be removed from all power supplies.
- Check that the plastic protective cover is on the CPU socket and none of the socket pins are bent. If they are, contact your retailer.
- When handling the processor, avoid touching or placing direct pressure on the LGA lands (gold contacts). Improper installation or socket misalignment can cause serious damage to the processor or socket, which may require manufacturer repairs.
- Refer to the Supermicro website for updates on processor support.

Installation Procedure Overview

After preparing the system, and following ESD precautions, there are four steps to installing the processor and heatsink onto the motherboard.

1. Attach the processor to a plastic carrier to create the processor carrier assembly.
2. Attach the processor carrier assembly to the heatsink to create the processor heatsink module (PHM).
3. Remove the socket cover.
4. Install the PHM.

Create the Processor Carrier Assembly

Assembling the Process Carrier Assembly

1. Hold the processor with the gold pins (LGA lands) facing down. Locate the gold triangle at the corner of the processor and the corresponding hollowed triangle on the processor carrier as shown below. These triangles indicate the location of pin 1.

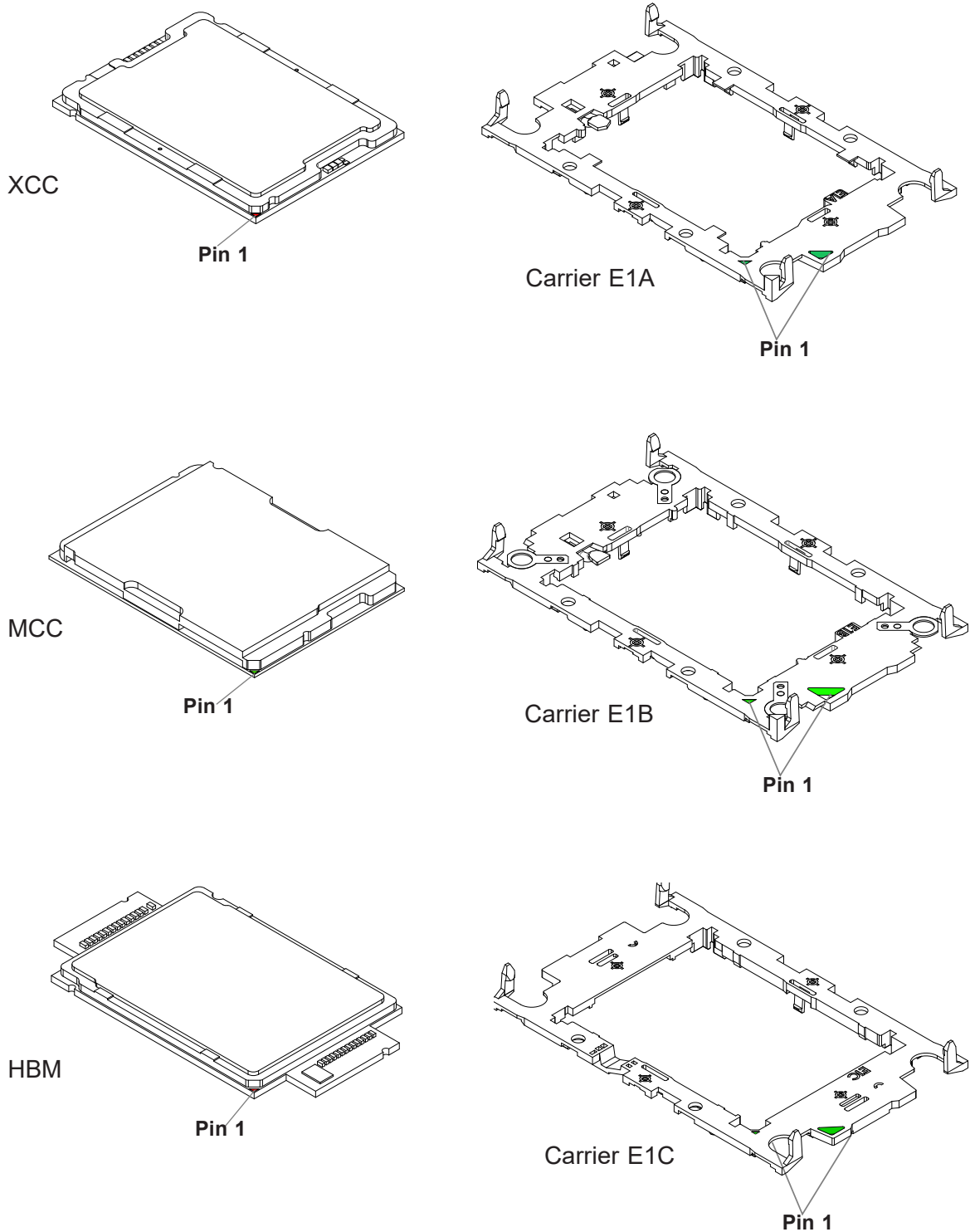

2. Turn the processor over (with the gold pins up). Locate the CPU keys on the processor and the four latches on the carrier.

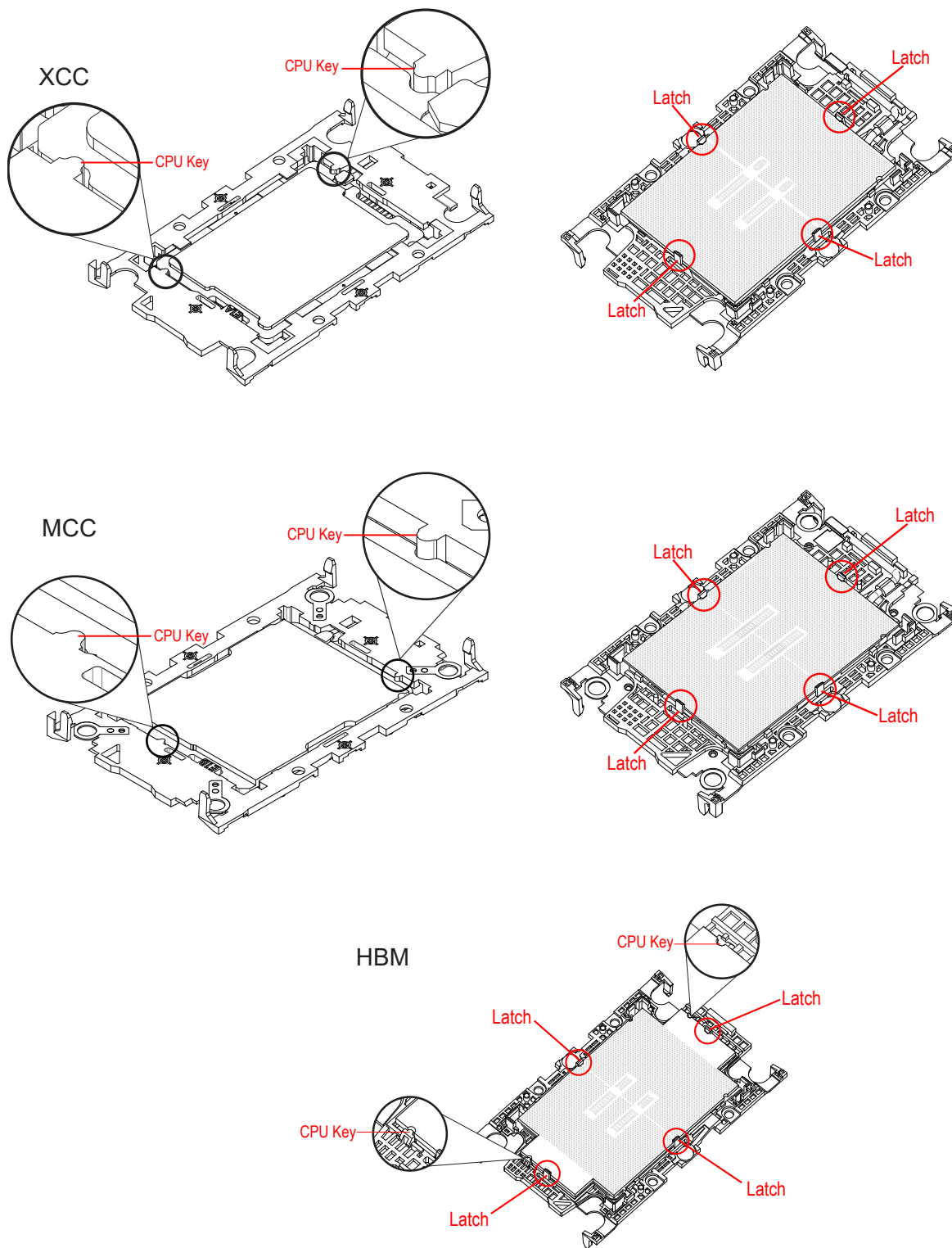

3. Locate the lever on the processor carrier and press it down (E1A and E1B only).

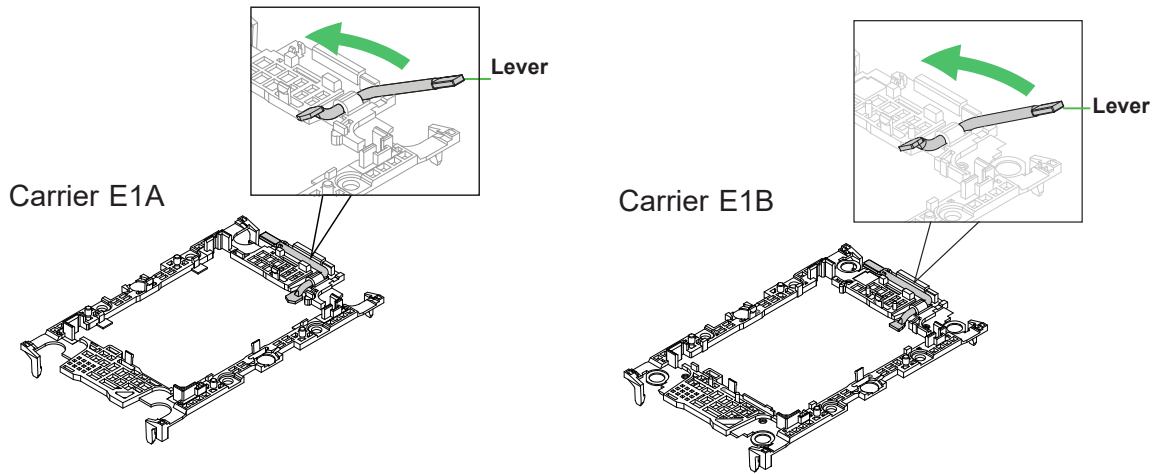

4. Using pin 1 as a guide, carefully align the CPU keys on the processor (A & B) with those on the carrier (a & b).

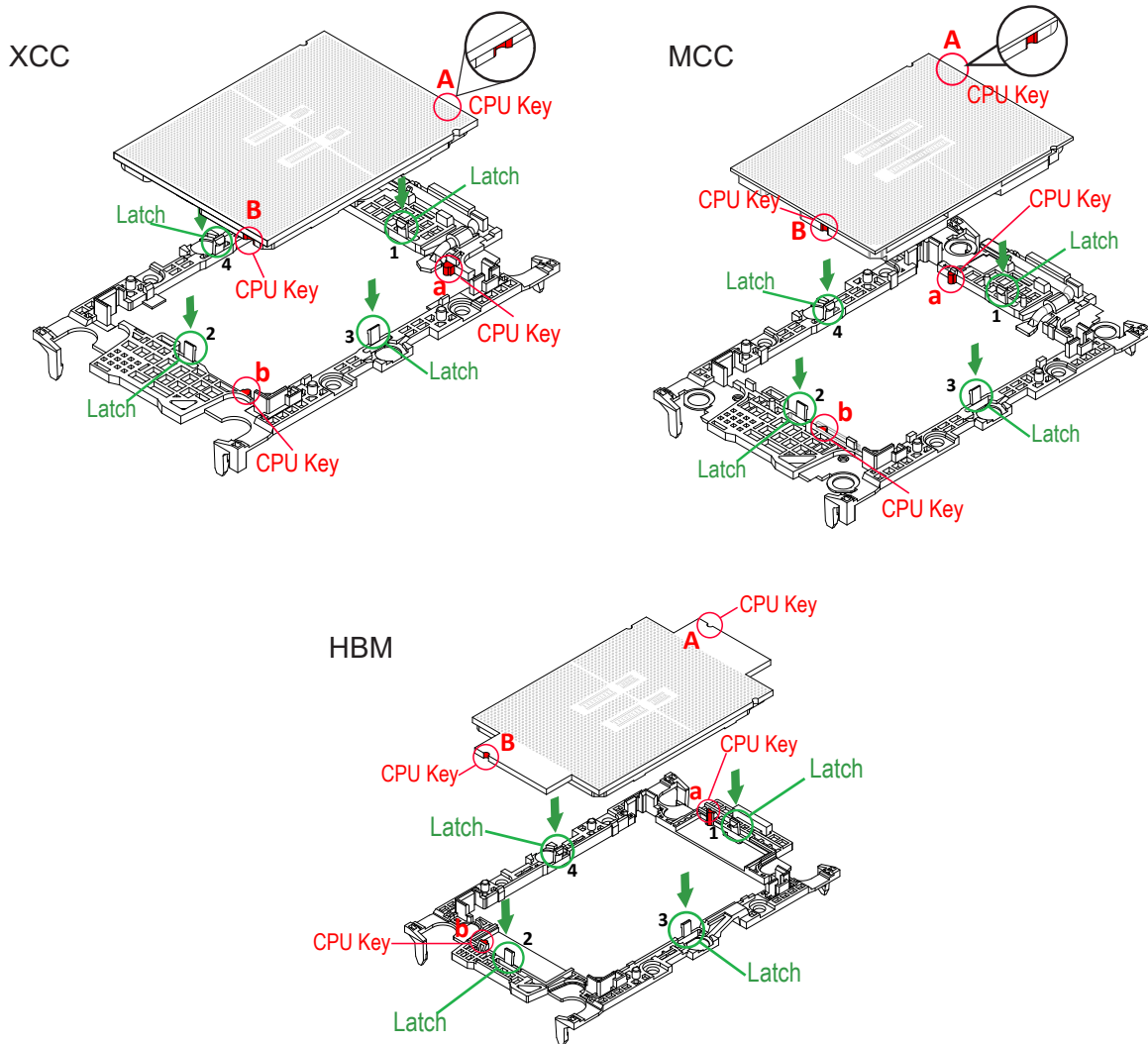

5. Once aligned, carefully insert the CPU into the carrier, making sure that the CPU is secured by latches 1, 2, 3, and 4.

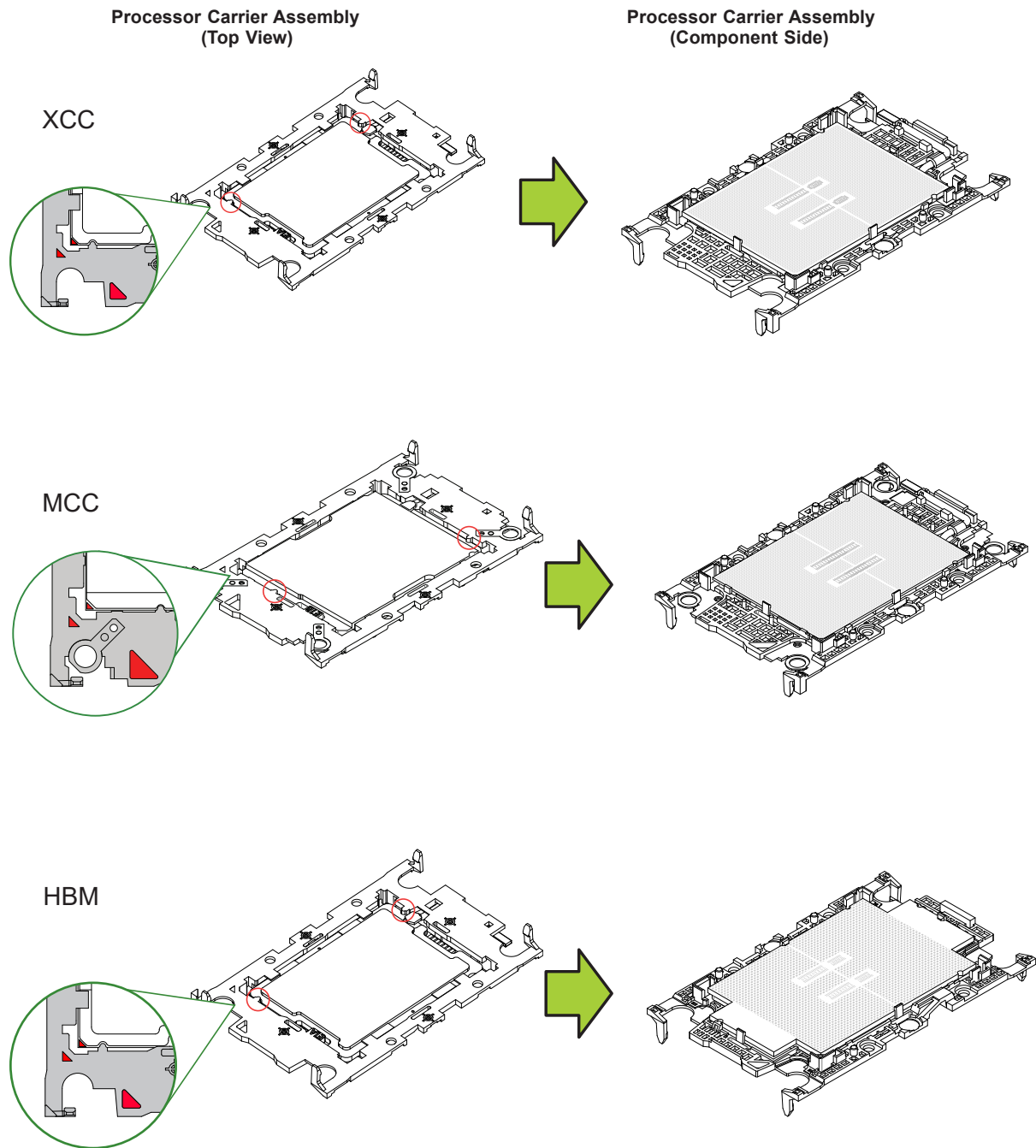

Assemble the Processor Heatsink Module

Thermal grease is pre-applied on a new heatsink. No additional thermal grease is needed. If this is a re-installation, apply the proper amount of thermal grease to the underside of the heatsink.

Assembling the Processor Heatsink Module (PHM)

1. Turn the heatsink over with the thermal grease facing up. Locate the two triangle cutouts (A, B) at the diagonal corners of the heatsink as shown in the drawing below.
2. Hold the processor carrier assembly component side up to locate the triangles on the processor and the carrier, which indicate pin 1.
3. Turn the processor carrier assembly over so that the gold pins are facing up, noting the two pin 1 locations ("A" on the processor and "a" on the processor carrier assembly).

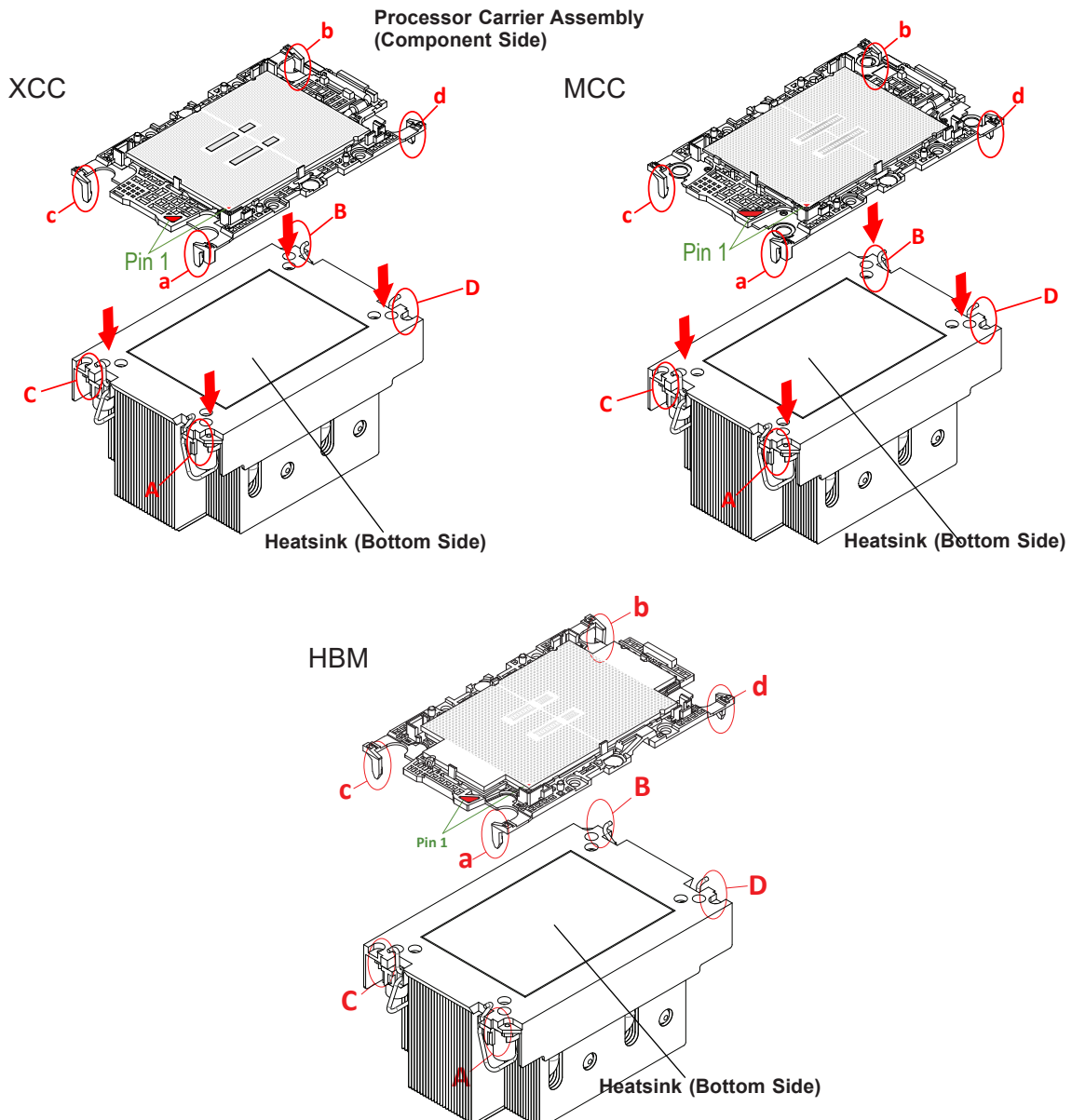

4. Align "a" on the processor carrier assembly with the triangular cutout "A" on the heatsink along with "b", "c", "d" on the processor assembly with "B", "C", "D" on the heatsink.
5. Once properly aligned, place the heatsink on the processor carrier assembly with all corners matched up, making sure that the four clips are properly securing the heatsink.

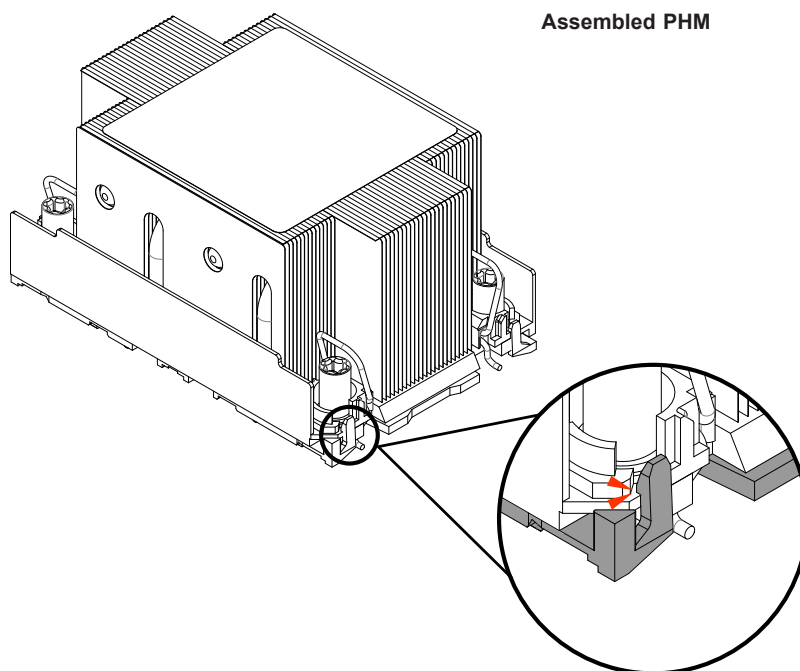

Note: The figure is for illustrative purposes. Your components may differ slightly from the components shown.

Remove the Socket Cover

Remove the plastic protective cover from the socket by gently squeezing the grip tabs and pulling the cover off.

CPU Socket with Plastic Protective Cover

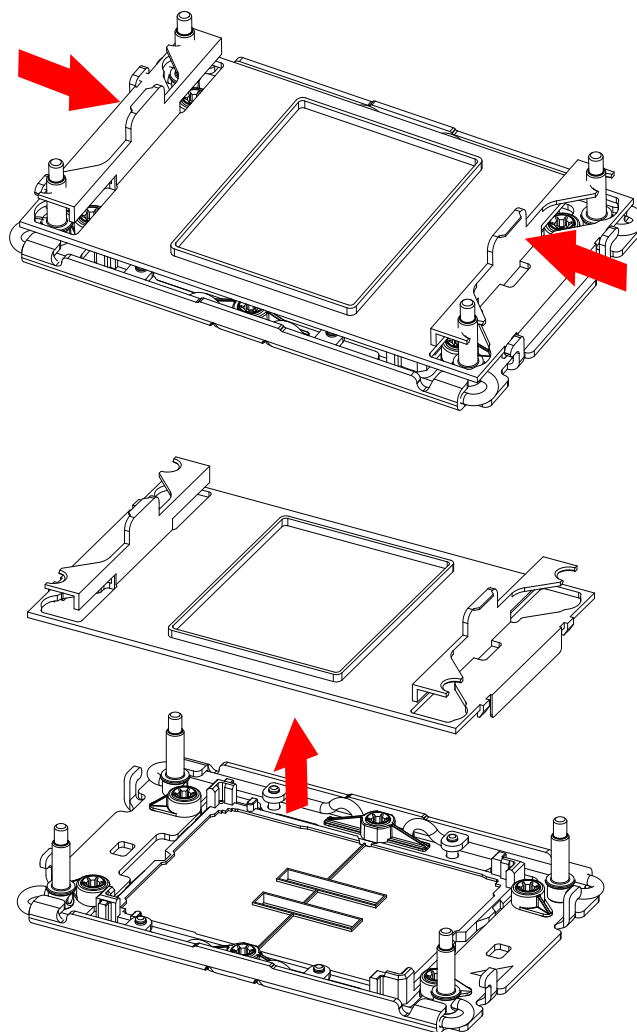

Install the PHM

To install the PHM into the CPU socket, follow these steps.

1. Locate four threaded fasteners (a, b, c, d) and Pin 1 on the CPU socket.

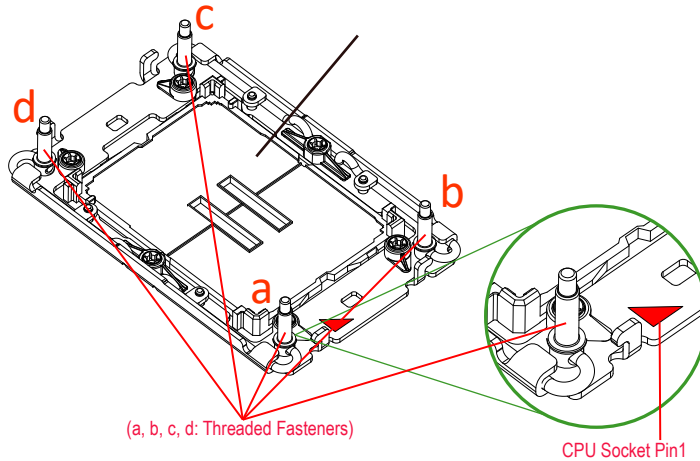

2. Locate four PEEK nuts (A, B, C, D) and four rotating wires (1, 2, 3, 4) on the heatsink.

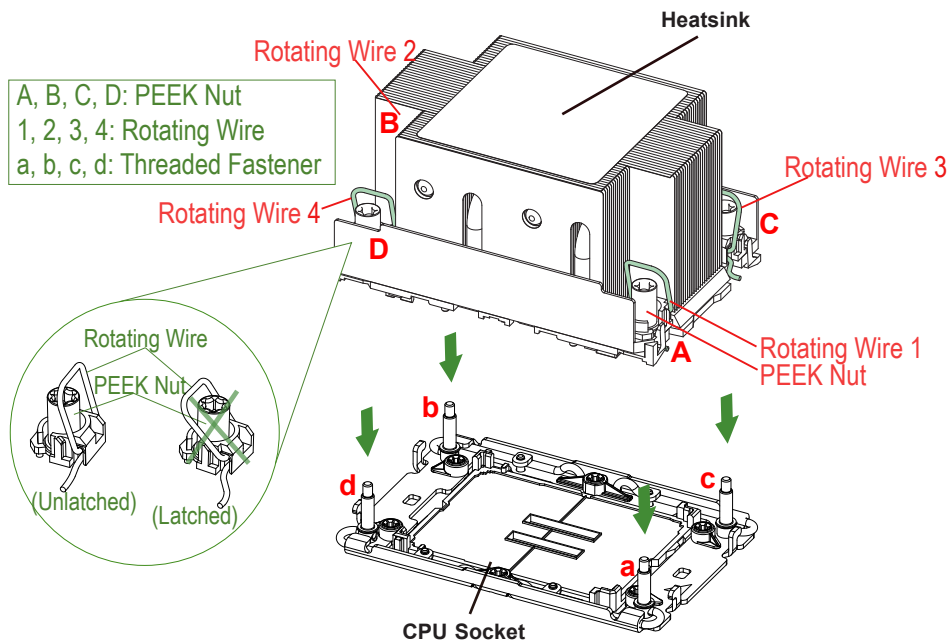

3. Check the rotating wires (1, 2, 3, 4) to make sure that they are in the unlatched position.

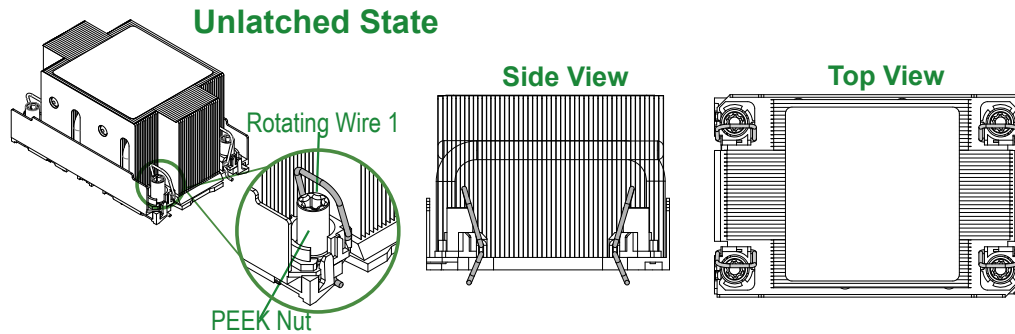

4. Align PEEK nut "A" (next to the triangular pin 1 on the heatsink) with threaded fastener "a" on the CPU socket. Then align PEEK nuts "B", "C", "D" on the heatsink with threaded fasteners "b", "c", "d" on the CPU socket.
5. Once aligned, gently place the PHM on the CPU socket, making sure that each PEEK nut is properly attached to its corresponding threaded fastener.

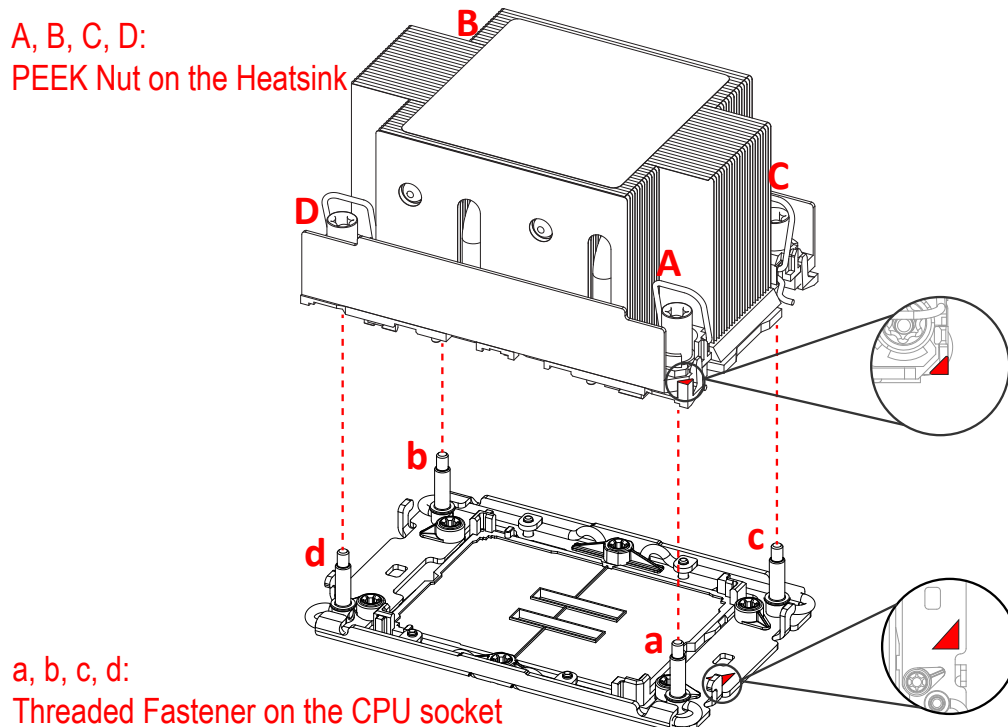

6. Press all four rotating wires outward and make sure that the heatsink is securely latched into the CPU socket.

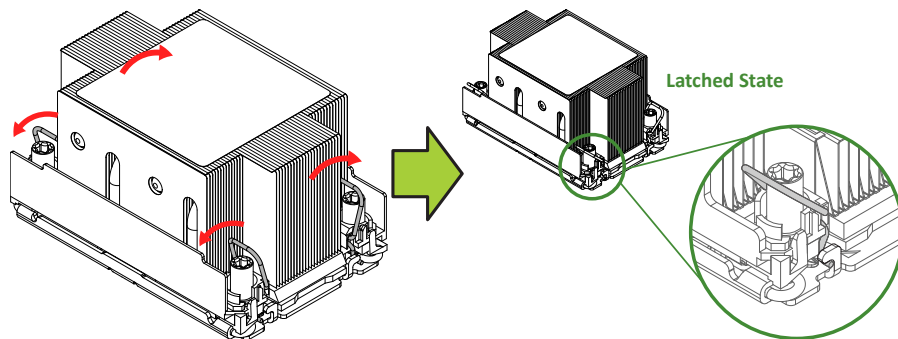

7. With a t30-bit screwdriver, tighten all PEEK nuts in the sequence of "A", "B", "C", and "D" with even pressure. Note the torque specifications written on the heatsink, and do not exceed them when tightening the screws.
8. Examine all corners of the heatsink to ensure that the PHM is firmly attached to the CPU socket.

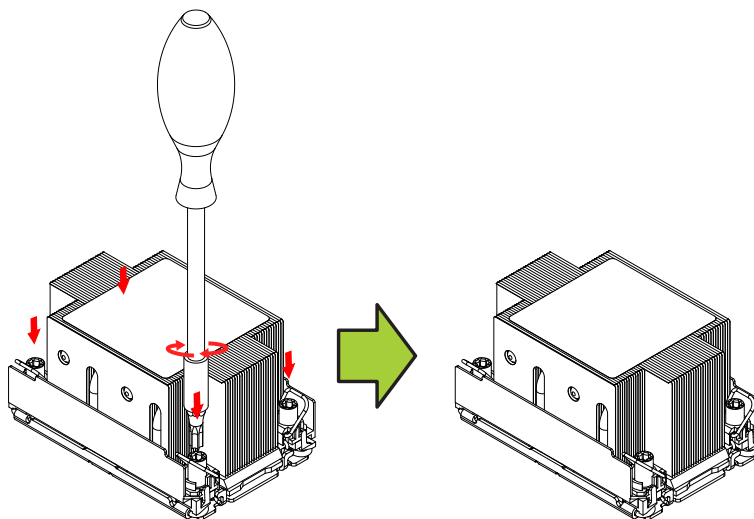

Removing the PHM

To remove the processor heatsink module (PHM) from the motherboard, follow these steps.

1. Shut down the system and unplug the AC power cord from all power supplies.
2. Use a T30-bit screwdriver to loosen the four PEEK nuts on the heatsink in the sequence of A, B, C, and D.

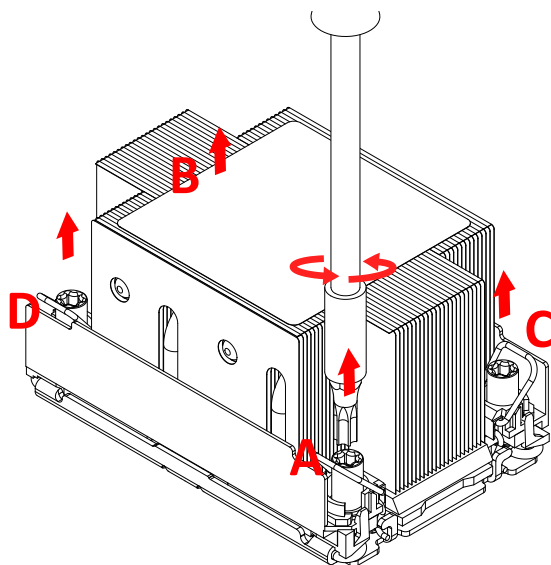

3. Press the rotating wires inward to unlatch the PHM from the socket as shown below.

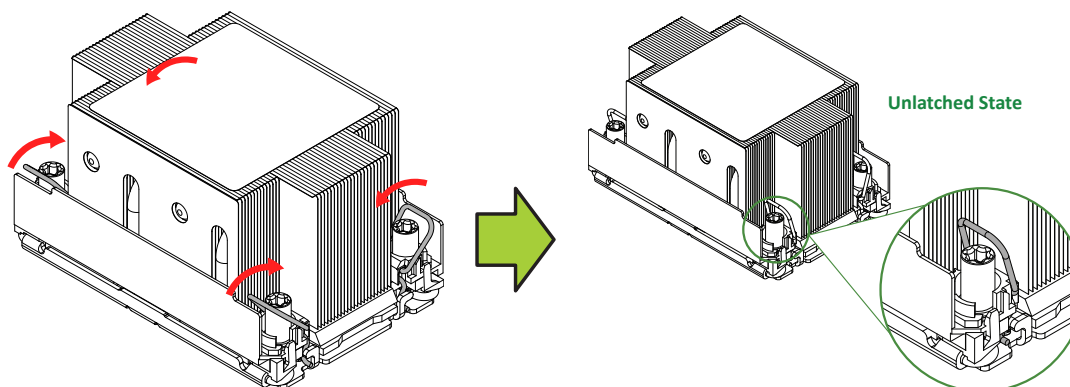

4. Gently lift the PHM upward to remove it from the CPU socket.

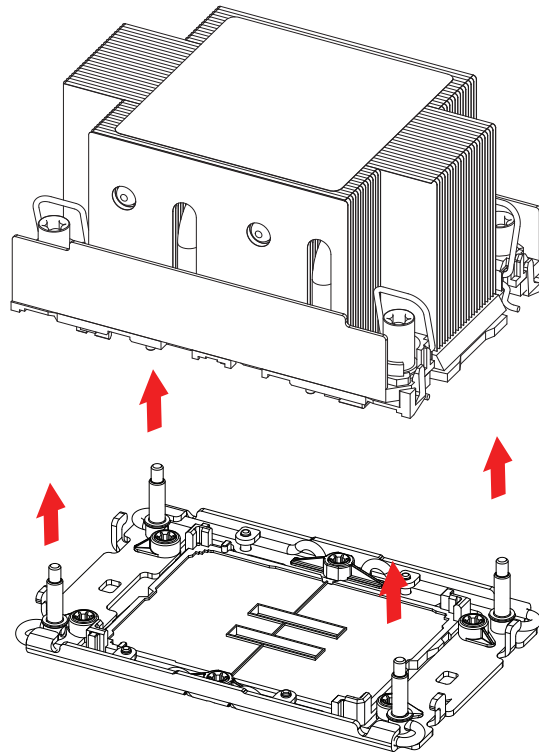

Removing the Carrier Assembly from the Heatsink

To remove the processor carrier assembly from the PHM, follow these steps:

1. Detach the four plastic clips (marked a, b, c, d) on the processor carrier assembly from the four corners of the heatsink (marked A, B, C, D) as shown below.

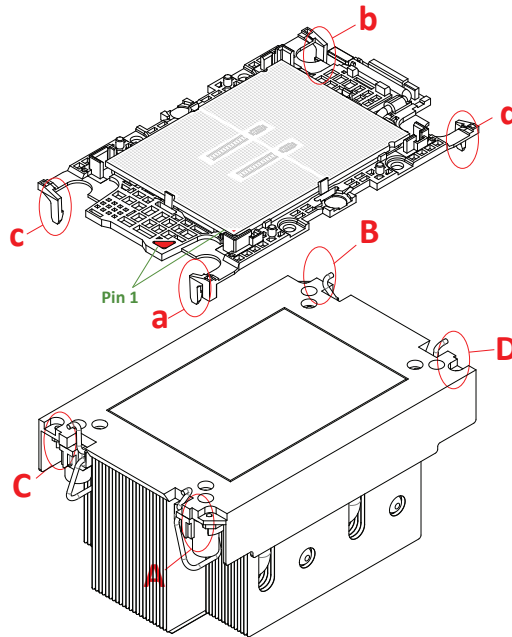

2. When all plastic clips have been detached from the heatsink, remove the processor carrier assembly from the heatsink

Removing the Processor from the Carrier Assembly

To remove the processor from the processor carrier, follow these steps.

1. Unlock the lever from its locked position and push it upwards to disengage the processor from the processor carrier as shown below right.

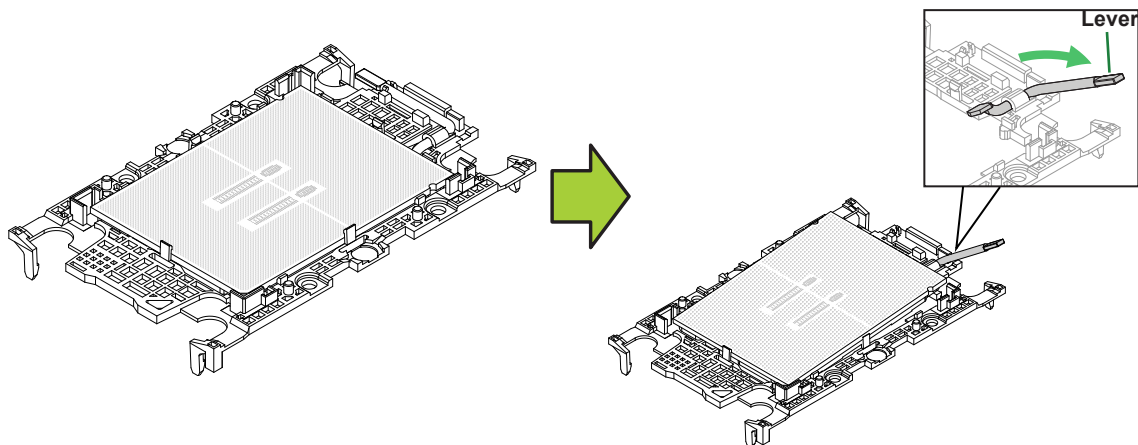

2. Once the processor has been loosened from the carrier, carefully remove the processor from the carrier.

Note: Handle the processor with care.

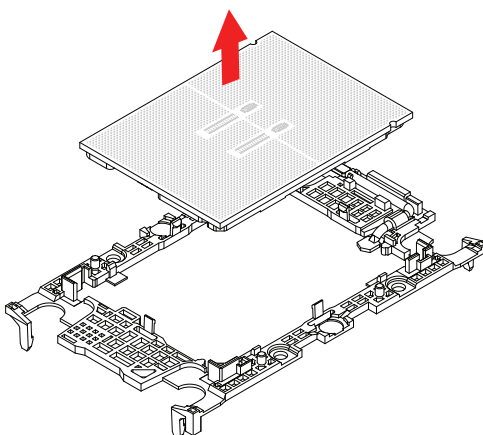

3.4 Memory

Memory Support

This motherboard supports up to 8 TB 3DS RDIMM/RDIMM DDR5 (288-pin) ECC memory with speeds up to 4800 MT/s (1DPC) / 4400 MT/s (2DPC) in 32 DIMM slots. LRDIMM/LRDIMM-3DS is not supported. For validated memory, use our [Product Resources page](#).

DDR5 Memory Support for the 4th Gen Intel Xeon Scalable Processors-SP					
Type	Ranks Per DIMM and Data Width (Stack)	DIMM Capacity (GB)		Speed (MT/s)	
				One DIMM per Channel ¹	Two DIMMs per Channel
		Memory Density 16 Gb	Memory Density 24Gb ²	1.1 Volts	
RDIMM	SRx8 (RC D)	16 GB	24 GB	4800*	4400*
	SRx4 (RC C)	32 GB	48 GB		
	SRx4 (RC F) 9x4	32 GB	NA		
	DRx8 (RC E)	32 GB	48 GB		
	DRx4 (RC A)	64 GB	96 GB		
	DRx4 (RC B) 9x4	64 GB	NA		
RDIMM 3DS	(4R/8R) x4 (RC A)	2H-128 GB 4H-256 GB	NA		

*Memory speed and capacity support depends on the processors used in the system.

Note 1: 1DPC applies to 1SPC or 2SPC implementations (SPC - sockets per channel).

Note 2: 24Gb XCC only with limited configs: 1DPC all DIMM types, 2DPC 96GB only. Only 8 and 16 DIMM configs, no failbacks. .

Key Parameters for DIMM Configurations	
Parameters	Possible Values
Number of Channels per Socket	1, 2, 4, 6, 8
Number of DIMMs per Channel	1DPC (1 DIMM Per Channel) or 2DPC (2 DIMMs Per Channel)
DIMM Type	RDIMM, 3DS RDIMM, and 9x4 RDIMMs
DIMM Construction	Non-3DS RDIMM Raw Cards: A (2Rx4), C (1Rx4), D (1Rx8), E (2Rx8) 3DS RDIMM Raw Cards: A (4Rx4, 8Rx4) 9x4 RDIMM Raw Cards: B (2Rx4), F (1Rx4)

Use the DIMM slots listed below for memory modules. This memory population table is based on guidelines provided by Intel to support Supermicro motherboards.

Memory Population, XCC and MCC CPUs, 32 DIMM Slots	
CPUs/DIMMs	DIMM Slots
2 CPUs & 2 DIMMs	CPU1 A1, and CPU2: A1 or CPU1 B1, and CPU2: B1 or CPU1 E1, and CPU2: E1 or CPU1 F1, and CPU2: F1
2 CPUs & 4 DIMMs	CPU1 A1, G1 and CPU2: A1, G1 or CPU1 C1, E1 and CPU2: C1, E1
2 CPUs & 8 DIMMs	CPU1: A1, C1, E1, G1, and CPU2: A1, C1, E1, G1
2 CPUs & 10 DIMMs	CPU1: A1, C1, D1, E1, F1, G1, and CPU2: A1, C1, E1, G1
2 CPUs & 12 DIMMs	CPU1: A1, C1, D1, E1, F1, G1 and CPU2: A1, C1, D1, E1, F1, G1 or CPU1: A1, B1, C1, E1, G1, H1 and CPU2: A1, B1, C1, E1, G1, H1 or CPU1: B1, C1, D1, E1, F1, H1 and CPU2: B1, C1, D1, E1, F1, H1 or CPU1: A1, B1, D1, F1, G1, H1 and CPU2: A1, B1, D1, F1, G1, H1
2 CPUs & 16 DIMMs	CPU1: A1, B1, C1, D1, E1, F1, G1, H1, and CPU2: A1, B1, C1, D1, E1, F1, G1, H1
2 CPUs & 22 DIMMs	CPU1: A1, A2, B1, B2, C1, C2, D1, D2, E1, E2, F1, F2, G1, G2, H1, H2 CPU2: A1, C1, D1, E1, F1, G1
2 CPUs & 24 DIMMs	CPU1: A1, A2, B1, B2, C1, C2, D1, D2, E1, E2, F1, F2, G1, G2, H1, H2 CPU2: A1, B1, C1, D1, E1, F1, G1, H1
2 CPUs & 32 DIMMs	CPU1: A1, A2, B1, B2, C1, C2, D1, D2, E1, E2, F1, F2, G1, G2, H1, H2 CPU2: A1, A2, B1, B2, C1, C2, D1, D2, E1, E2, F1, F2, G1, G2, H1, H2

Memory Population, Max CPU, 32 DIMM Slots	
CPUs/DIMMs	DIMM Slots
2 CPUs & 2 DIMMs	CPU1 A1, and CPU2: A1 or CPU1 E1, and CPU2: E1
2 CPUs & 4 DIMMs	CPU1 A1, G1 and CPU2: A1, G1 or CPU1 C1, E1 and CPU2: C1, E1
2 CPUs & 8 DIMMs	CPU1: A1, C1, E1, G1, and CPU2: A1, C1, E1, G1
2 CPUs & 16 DIMMs	CPU1: A1, B1, C1, D1, E1, F1, G1, H1, and CPU2: A1, B1, C1, D1, E1, F1, G1, H1
2 CPUs & 32 DIMMs	CPU1: A1, A2, B1, B2, C1, C2, D1, D2, E1, E2, F1, F2, G1, G2, H1, H2 CPU2: A1, A2, B1, B2, C1, C2, D1, D2, E1, E2, F1, F2, G1, G2, H1, H2

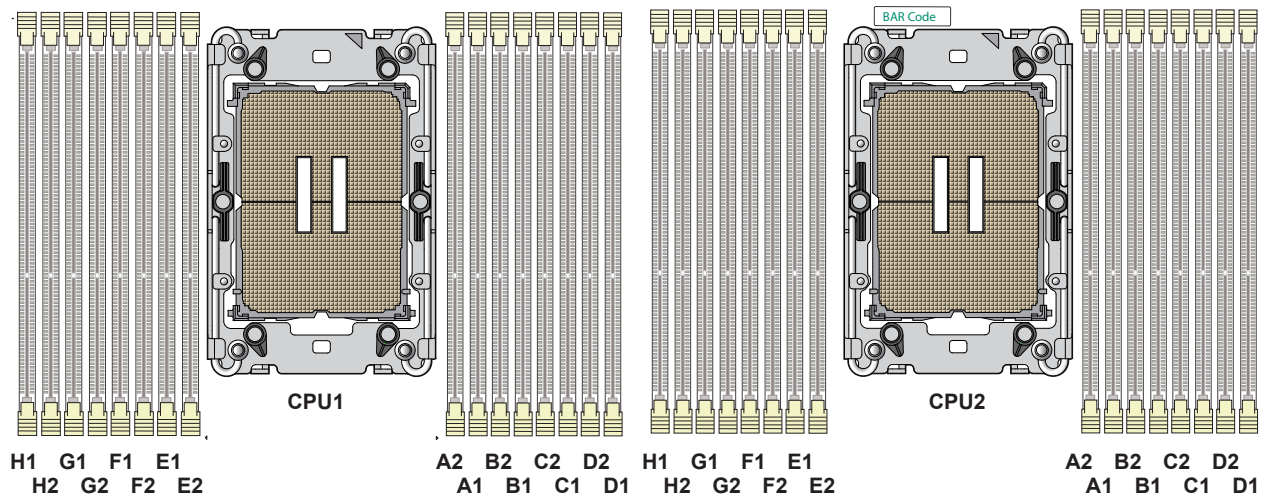

Figure 3-5. Memory Slots

Memory Population Guidelines

- 16 and 32 DIMM configurations are preferred to achieve HGX GPU memory utilization recommendations.
- All DIMMs must be DDR5.
- Balance memory. Using unbalanced memory topology, such as populating two DIMMs in one channel while populating one DIMM in another channel, reduces performance. It is not recommended for Supermicro systems.

Guidelines Regarding Mixing DIMMs

- Mixing memory modules of different types, speeds, ranks and vendors is very likely to cause performance issues, and therefore not recommended.
- Populating slots with a pair of DIMM modules of the same type and size results in interleaved memory, which improves memory performance.
- x4 and x8 DIMMs can be mixed in the same channel.
- LRDIMMs are not supported.

DIMM Construction

- RDIMM (*non-3DS*) Raw Cards: A/B (2Rx4), C (1Rx4), D (1Rx8), E (2Rx8)
- 3DS RDIMM Raw Cards: A/B (4Rx4)

Max Series CPUs

Notes:

- Max Series (HBM) CPU supports 1DPC (4800 MT/s) / 2DPC (4400 MT/s) to optimize the memory bandwidth. Max Series (HBM) CPU supports 1, 2, 4, 8, or 16 DIMMs in Flat Mode as well as Cache Mode, and 0 DIMMs in HBM-Only mode. HBM-Only mode runs exclusively using HBM memory.
- SPR+HBM supports 4, 8, or 16 DIMMs in all modes (Flat / Cached and Quadrant / SNC4)
 - 4 DIMMs -> populate 1 DIMM/iMC
 - 8 DIMMs -> populate 1 DIMM/Channel, 2 DIMM/iMC
 - 16 DIMMs -> populate 1 DIMM/Channel, 4 DIMM/iMC
- All other configurations not listed above are not supported.
- For 2S design, each socket has to be populated identically.

Installing Memory

Electrostatic Discharge (ESD) can damage electronic components including memory modules. To avoid damaging DIMM modules, it is important to handle them carefully. The following measures are generally sufficient.

- Use a grounded wrist strap designed to prevent static discharge.
- Handle the memory module by its edges only.
- Put the memory modules into the antistatic bags when not in use.

Installing Memory

Begin by removing power from the system as described in Section 3.1. Follow the memory population sequence in the table above.

1. Push the release tabs outwards on both ends of the DIMM slot to unlock it.

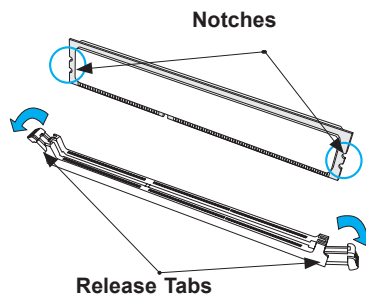

2. Align the key of the DIMM with the receptive point on the memory slot and with your thumbs on both ends of the module, press it straight down into the slot until the module snaps into place.

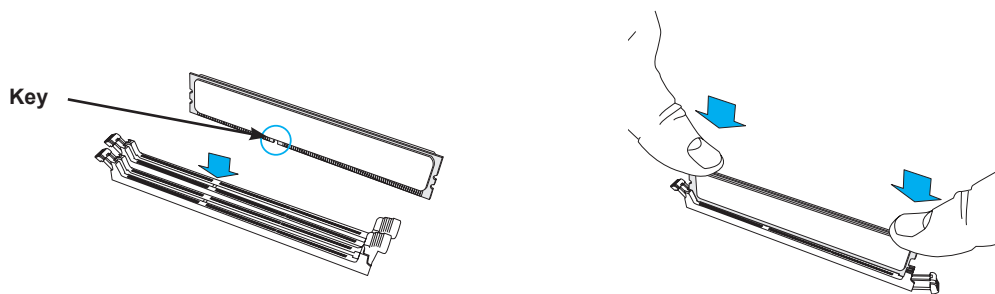

3. Press the release tabs to the locked position to secure the DIMM module into the slot.

Caution: Exercise extreme caution when installing or removing memory modules to prevent damage to the DIMMs or slots.

Removing Memory

To remove a DIMM, unlock the release tabs then pull the DIMM from the memory slot.

3.5 Motherboard Battery

The motherboard uses non-volatile memory to retain system information when system power is removed. This memory is powered by a lithium battery residing on the motherboard.

Replacing the Battery

Begin by [removing power](#) from the system.

1. Push aside the small clamp that covers the edge of the battery. When the battery is released, lift it out of the holder.
2. To insert a new battery, slide one edge under the lip of the holder with the positive (+) side facing up. Then push the other side down until the clamp snaps over it.

Note: Handle used batteries carefully. Do not damage the battery in any way; a damaged battery may release hazardous materials into the environment. Do not discard a used battery in the garbage or a public landfill. Please comply with the regulations set up by your local hazardous waste management agency to dispose of your used battery properly.

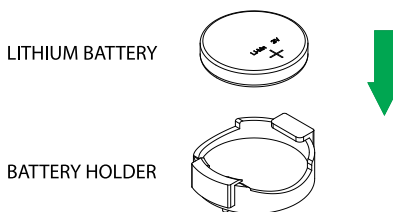

Figure 3-6. Installing the Onboard Battery



Warning: There is a danger of explosion if the onboard battery is installed upside down (which reverses its polarities). This battery must be replaced only with the same or an equivalent type recommended by the manufacturer (CR2032).

3.6 Storage Drives

The system supports sixteen 2.5" NVMe storage drives and three 2.5" SATA storage drives. The drives are mounted in tool-less drive carriers that simplify their removal from the chassis. These carriers also help promote proper airflow. Drive carrier status indicators are described in [Section 1.2](#).

Note: Enterprise level storage drives are recommended for use in Supermicro servers. For compatible storage drives, see the [system web page](#).

Installing Hot-Swap Drives



Figure 3-7. Logical Drive Numbers

Logical Storage Drive Numbers	
Item	Description
0 to 15	Sixteen 2.5-inch hot-swap NVMe drive bays
16 to 18	Three 2.5-inch hot-swap SATA drive bays

To install drives, first remove the drive carrier from the system.

Removing a Hot-Swap Drive Carrier

1. Press the release button on the drive carrier, which will extend the drive carrier handle.
2. Use the drive carrier handle to pull the drive out of the chassis.

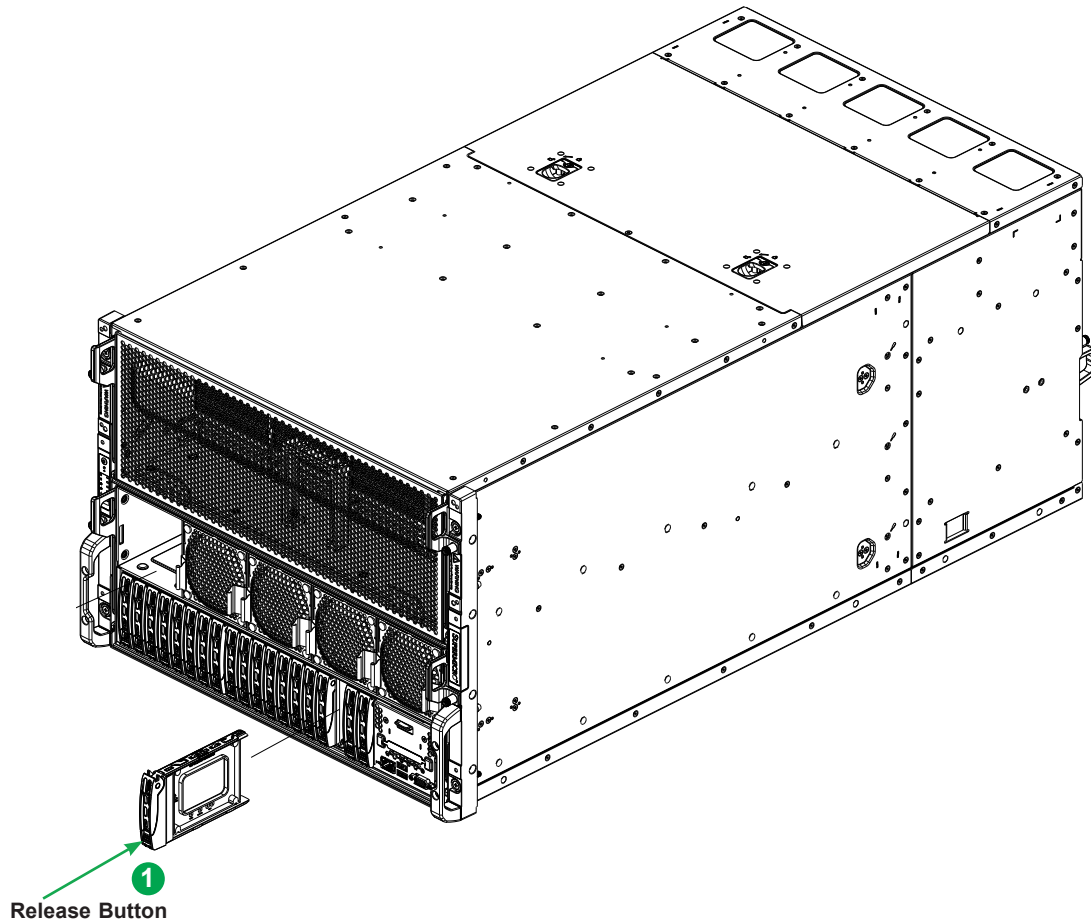

Figure 3-8. Removing a Drive Carrier

Installing a Drive

1. Remove the dummy drive, which comes pre-installed in the drive carrier. Pull out the two locking clasps on the left outside of the carrier and lift out the dummy drive.
2. Position the drive above the carrier with the PCB side facing down and the connector end toward the rear of the carrier.

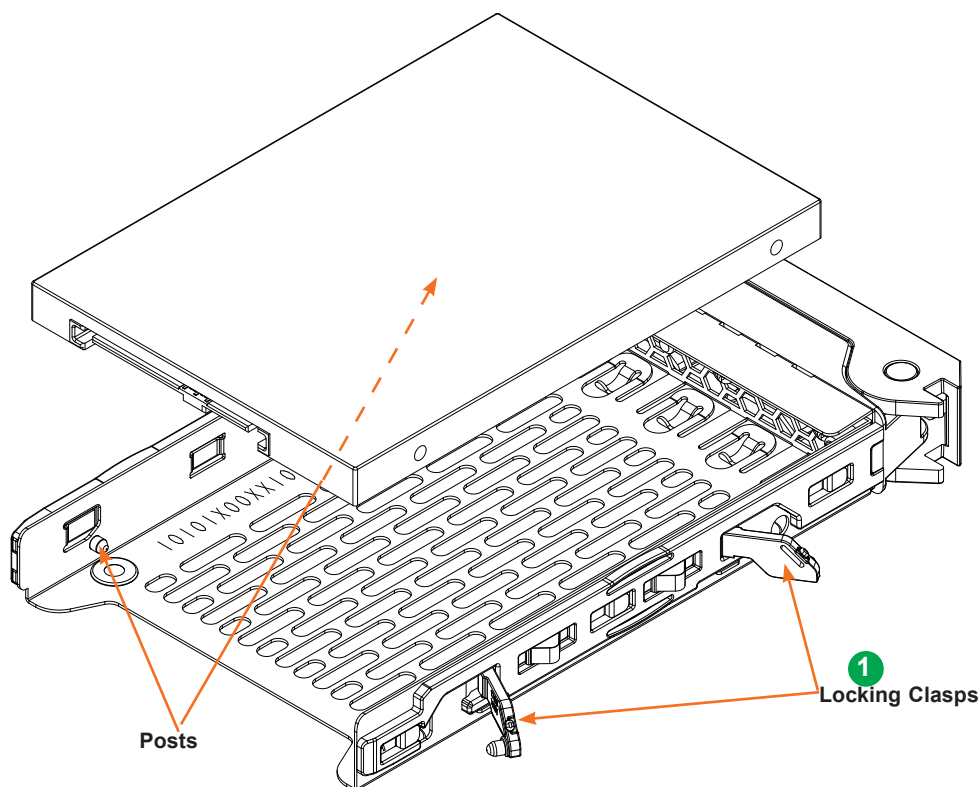

Figure 3-9. Installing a Drive into a Carrier

3. Tilt the drive to insert it onto the two posts inside of the carrier.
4. Pull out the two spring locking clasps and allow the drive to sit fully in the carrier, then close them to secure the drive.
5. Insert the drive carrier into its bay, keeping the release button on the bottom. When the carrier reaches the rear of the bay, the release handle will retract.
6. Push the handle in until it clicks into its locked position

M.2 Drives

The system supports two M.2 NVMe SSDs. They are located underneath the switch module, and should be installed or replaced by the manufacturer.

Checking the Temperature of an NVMe Drive

There are two ways to check using the BMC Dashboard.

Checking a Drive

- **BMC Dashboard > Server Health > NVMe SSD** – Shows the temperatures of all NVMe drives.
- **BMC Dashboard > Server Health > Sensor Reading > NVME_SSD** – Shows the single highest temperature among all the NVMe drives.

3.7 System Cooling

Multiple 8-cm fans provide the cooling for the system. Fans may be replaced while the system continues to operate. Cooling is aided by louvers in the chassis that help prevent expelled hot air from returning into the chassis.

Changing a System Fan

To replace fans in the chassis front, or on the top row of the chassis rear. The logical fan numbering is shown in [Chapter 1](#).

1. Determine which fan is failing. If possible, use the BMC.
2. Pinch the metal release latches on each side of the fan, and pull the fan out.
3. Place the replacement fan into the vacant space. Push until the latches click and the fan is secure.

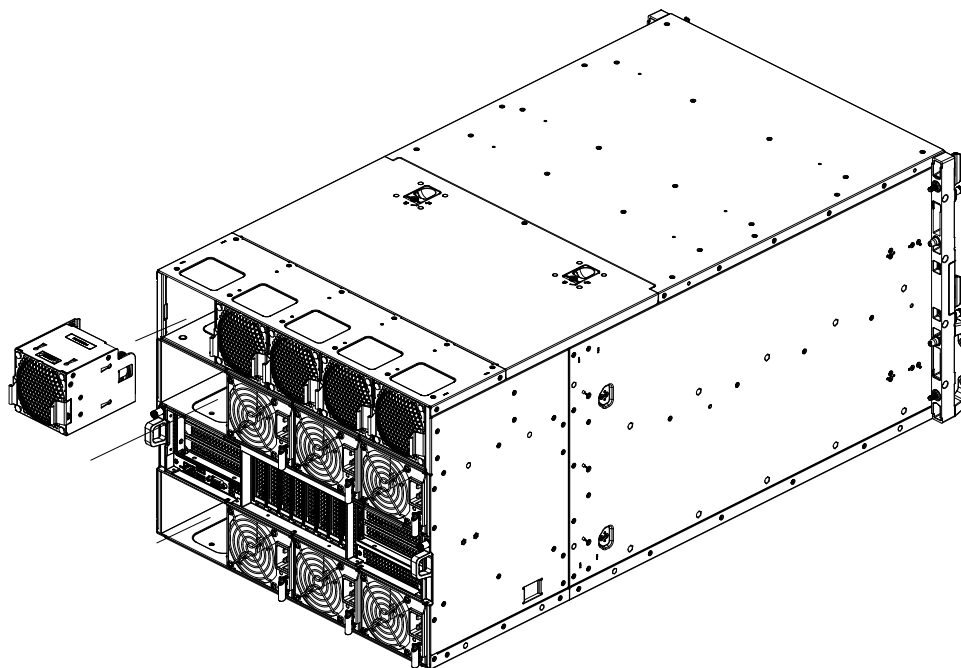

Figure 3-10. Replacing the Fans

To replace a power supply/fan combination, see the [Power Supply](#) section.

Motherboard Air Shroud

The air shroud system concentrates airflow to maximize fan efficiency. It is installed on the motherboard tray around the CPU heatsinks, and above the DIMMs.

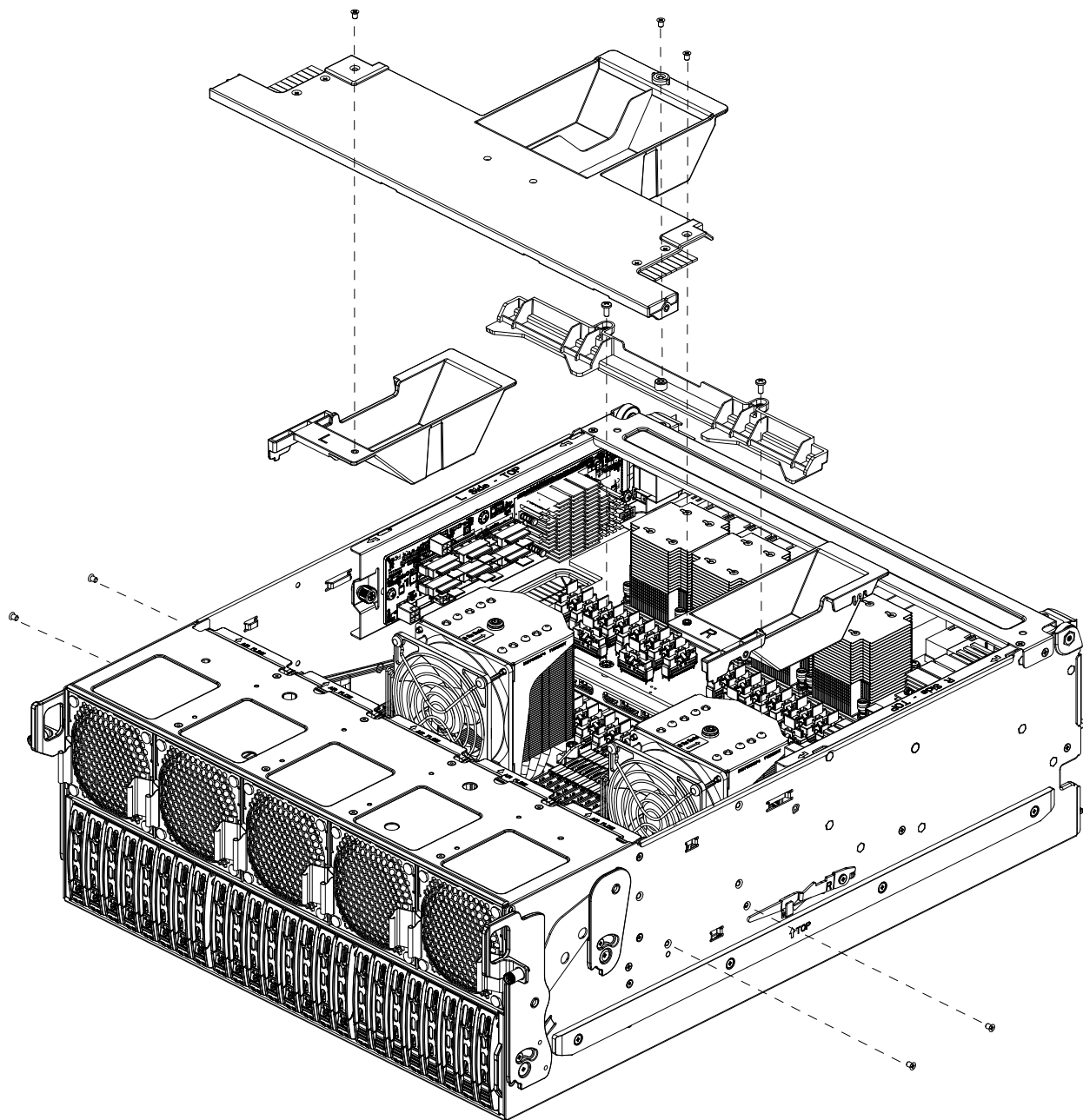

Figure 3-11. Installing the Motherboard Air Shrouds

3.8 Power Supply

The system features redundant power supplies. The power modules can be changed without powering down the system, but only up to the redundancy supported. Standard configuration supports 3 + 3 redundancy. Up to three modules can be offline for service, although that is not recommended. New units can be ordered directly from Supermicro or authorized distributors.

Power Supply LEDs

On the rear of the power supply module, an LED displays the status.

Power Supply Indicator	
LED Color and State	Power Supply Condition
Solid Green	Indicates that the power supply is on
Blinking Green	Indicates that the power supply is plugged in and turned off by the system.
Blinking Amber	Indicates that the power supply has a warning condition and continues to operate.
Solid Amber	Indicates that the power supply is plugged in, and is in an abnormal state. The system might need service. Please contact Supermicro technical support.
Off	No AC power to modules

Replacing the Power Supply

The logical power supply module numbering is shown in [Chapter 1](#).

1. Unplug the AC cord from the module to be replaced.
2. Pull the release handle on the back of the power supply as illustrated.
3. Pull the power supply out using the handle.
4. Replace the failed power module with the same model.
5. Push the new power supply module into the power bay until it clicks.
6. Plug the AC power cord back into the module.

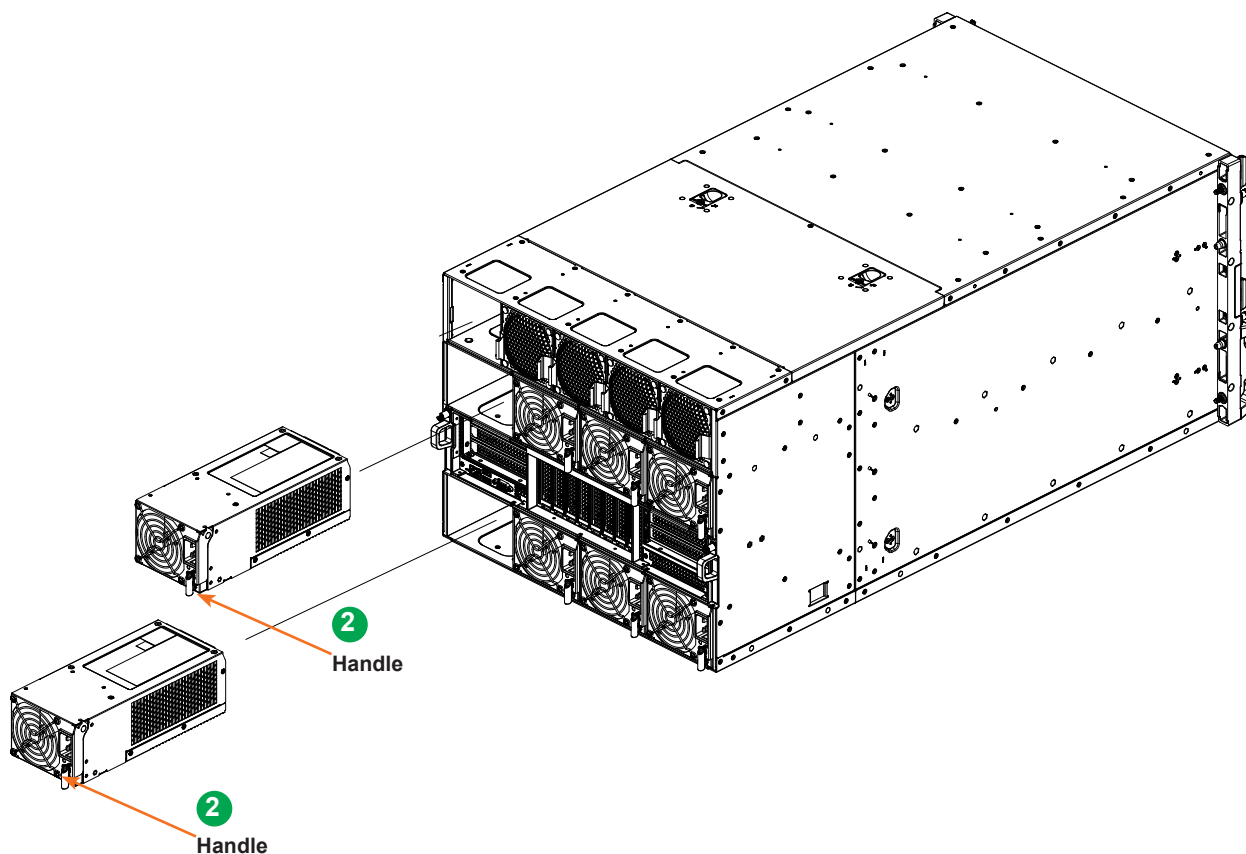

Figure 3-13. Installing a Power Supply Module

3.9 PCIe Expansion Cards

The default system can accommodate 10 PCIe cards. An optional kit can be added to support two more

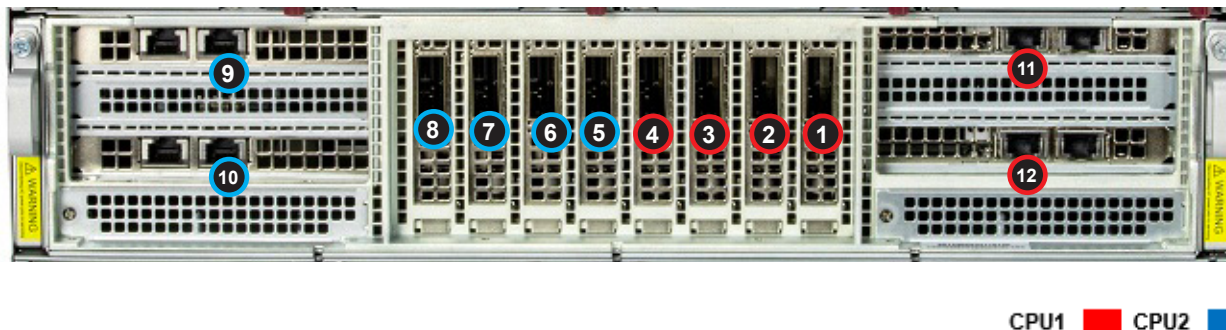

Figure 3-14. Expansion Cards

Expansion Slot Locations	
Slot	Description
1	PCIe 5.0 x16 (LP) from PLX switch to GPUs
2	PCIe 5.0 x16 (LP) from PLX switch to GPUs
3	PCIe 5.0 x16 (LP) from PLX switch to GPUs
4	PCIe 5.0 x16 (LP) from PLX switch to GPUs
5	PCIe 5.0 x16 (LP) from PLX switch to GPUs
6	PCIe 5.0 x16 (LP) from PLX switch to GPUs
7	PCIe 5.0 x16 (LP) from PLX switch to GPUs
8	PCIe 5.0 x16 (LP) from PLX switch to GPUs
9	PCIe 5.0 x16 (FHFL) (requires an optional NIC kit)
10	PCIe 5.0 x16 (FHFL) (requires an optional NIC kit)
11	PCIe 5.0 x16 (FHFL, double width)
12	PCIe 5.0 x16 (FHFL, double width)

Installing Expansion Cards (1–8)

1. [Power down](#) the system and pull out the PCIe expansion tray as described in [Section 3.2](#).
2. In the front of the tray, remove the blank PCI shield.
3. Slide the expansion card into the PCIe slot on the PCIe expansion tray floor while aligning the bracket with the chassis. It may be helpful to remove one of the riser card brackets to allow room to work (see next subsection).
4. Push the PCIe expansion tray into the chassis.

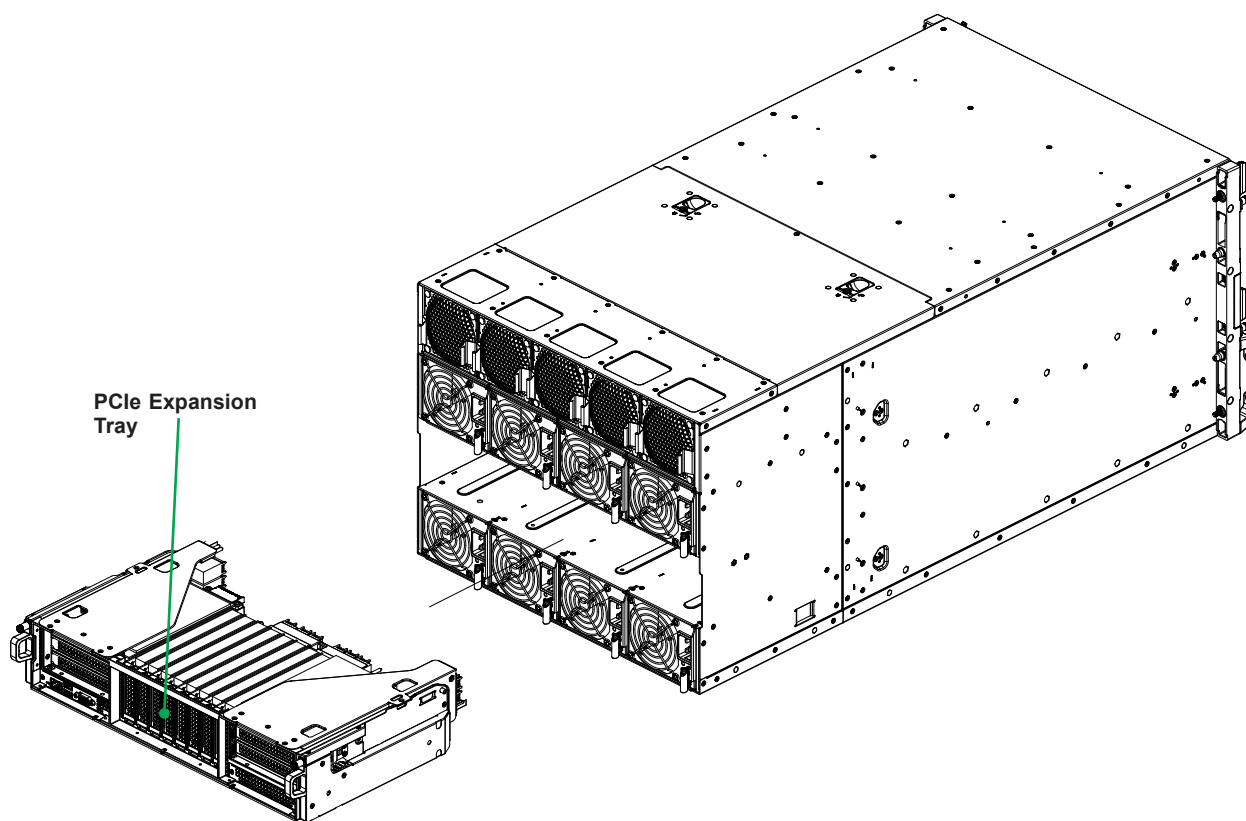

Figure 3-15. Adding Expansion Cards (1–8)

Installing Riser Expansion Cards (9–12)

Expansion cards can be added for slots 9–12 by means of riser cards mounted on riser card brackets as shown below.

1. [Power down](#) the system and remove the PCIe tray as described in [Section 3.2](#).
2. Unscrew (four screws for each) and remove the riser card bracket for the slots you want to use.

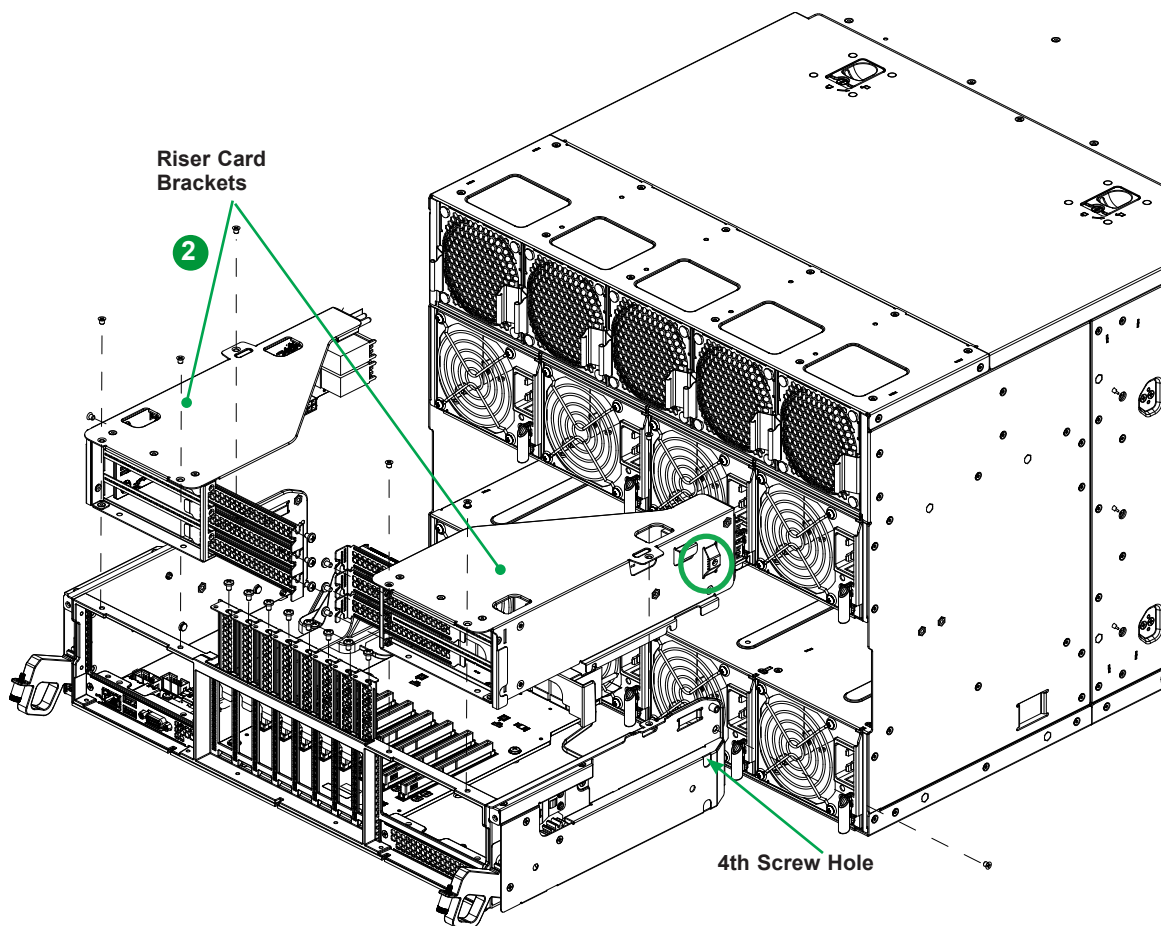

Figure 3-16. Removing Riser Card Brackets and Shields

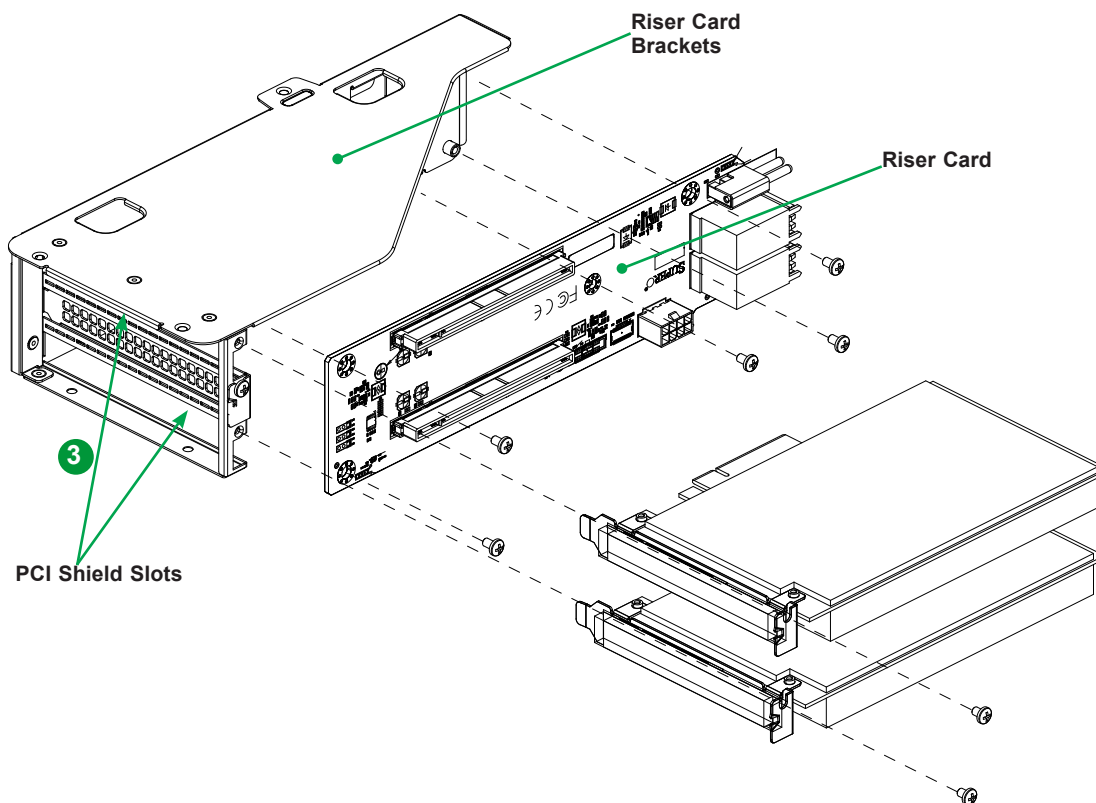

Figure 3-17. Riser Card Brackets and Shields

3. Remove the blank PCI shield that covers the bracket slot.
4. Slide the expansion card(s) into the slot(s) on the riser card while aligning the shield(s) with the bracket.
5. Return the brackets to the PCIe tray and the PCIe tray into the chassis.

Chapter 4

Motherboard Connections

This section describes the connections on the motherboard and provides pinout definitions. Note that depending on how the system is configured, not all connections are required. The LEDs on the motherboard are also described here. A motherboard layout indicating component locations may be found in [Chapter 1](#). More detail can be found in the [Motherboard Manual](#). Please review the Safety Precautions in [Appendix A](#) before installing or removing components.

4.1 Rear Connectors



Figure 4-1. Motherboard Rear Connectors

The rear connectors are for the power delivery boards.

4.2 Power Connections

Power Supply Connectors

Two power supply connectors, located at PSU1 and PSU4, provide main power to your system. Twelve 8-pin power connectors (GPU-PWR1–6, GPU-PWR15–20) and six 8-pin power connectors (BP-PWR1–6) can be used to provide power to additional devices. All the 8-pin power connectors meet the ATX SSI EPS 12V specification

One 8-pin connector is used for each AOM-GP801-SW/ADP installed.

8-pin Power Pin Definitions	
Pin#	Definition
1 - 4	Ground
5 - 8	+12V

Required Connection

4.3 Headers and Connectors

Fan Headers

Two 4-pin fan headers (FAN9, FAN10) are used to power and control the active CPU heatsink fans. Fan speed control for these fans is supported by Thermal Management using the BMC 2.0 interface.

4-pin Fan Header Pin Definitions	
Pin#	Definition
1	Ground (Black)
2	+12V (Red)
3	Tachometer
4	PWM Control

TPM/Port 80 Header

The JTPM1 header is used to connect a TPM Module for Trust Platform Module/Port 80 support. The TPM module, which is optional and available from Supermicro, is a security device that supports encryption and authentication in storage drives. It allows the motherboard to deny access if the TPM associated with the storage drive is not installed in the system. See the layout below for the location of the TPM header. Please go to the following link for more information on the TPM: <https://www.supermicro.com/manuals/other/TPM.pdf>.

Trusted Platform Module Header Pin Definitions			
Pin#	Definition	Pin#	Definition
1	+3.3V	2	SPI_CS#
3	RESET#	4	SPI_MISO
5	SPI_CLK	6	GND
7	SPI_MOSI	8	NC
9	+3.3V Stdbby	10	SPI_IRQ#

BMC External I²C Header

A System Management Bus 6-pin header for BMC is located at JIPMB1. Connect a cable to this header to use the IPMB I²C connection on your system.

NC-SI Connector

The NC-SI (Network Controller Sideband Interface) connector is located at (JNCSI1). This connector is used to connect a Network Interface Card (NIC) to the motherboard to allow the onboard BMC (Baseboard Controller) to communicate with a network.

Note: For detailed instructions on how to configure Network Interface Card (NIC) settings, please refer to the Network Interface Card Configuration User's Guide posted on the web page under the link: <http://www.supermicro.com/support/manuals/>.

PCIe 3.0 M.2 Slots

Two M.2 slots are located at M.2-P1 and M.2-P2. They support PCIe 3.0 x2 M.2 NVMe SSDs in the 2280 and 22110 form factors. Two mounting holes are provided on the motherboard. Use mounting hole MH15 or MH16 for M.2-P2 slot support, and MH17 or MH18 for M.2-P1 slot support.

MCIO NVMe Connectors

MCIO NVMe connectors, located at P1-PCIE1A/1B/2A/2B/3A/3B/4A/4B/5A/5B and P2-PCIE1A/1B/2A/2B/3A/3B/4A/4B/5A/5B, provide twenty PCIe 5.0 x16 connections on the motherboard. P1-PCIE1A–5B connections are supported by CPU1, and P2-PCIE1A–5B connections are supported by CPU2. Use these MCIO connectors to support high-speed PCIe storage devices.

Note: When installing an NVMe device on a motherboard, connect the first NVMe port (P1-PCIE1A and P1-PCIE1A) first for your system to work properly.

I-SATA 3.0 0–7 Ports

Two SATA 3.0 headers, located at JS1 and JS2, support three SATA 3.0 connections (SATA0–7). These SATA 3.0 ports are supported by the Intel PCH C741 chipset. Connect a proper SATA cable to JS1 and JS2 to use SATA 3.0 connections.

I/O Connector

An I/O riser connector, located on JSLOT1, provides dedicated BMC LAN/USB/VGA support on the rear side of the motherboard.

4.4 Jumpers

Explanation of Jumpers

To modify the operation of the motherboard, jumpers are used to choose between optional settings. Jumpers create shorts between two pins to change the function associated with it. Pin 1 is identified with a square solder pad on the printed circuit board. See the motherboard layout page for jumper locations.

Note: On a two-pin jumper, "Closed" means the jumper is on both pins and "Open" indicates the jumper is either on only one pin or has been completely removed.

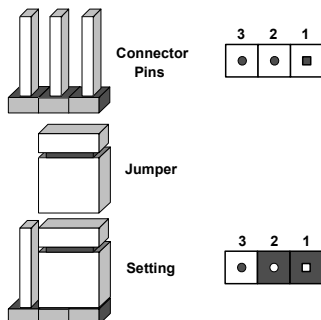

CMOS Clear

JBT1 is used to clear CMOS. See [Section 7.7](#) for details.

BMC and PCH I²C/SDA to VRM and BMC and PCH I²C/SCI to VRM Select Jumper

Use jumpers JVRM1 and JVRM2 to select between BMC and PCH I²C/SDA for VRM support or BMC and PCH I²C/SCI for VRM support. Connect a cable to JVRM1 to enable BMC and PCH I²C/SDA for VRM support.

BMC and PCH I ² C/SDA to VRM and BMC and PCH I ² C/SCL to VRM Select Jumper Jumper Settings	
Jumper Setting	Definition
Closed	BMC and PCH I ² C/SDA for VRM support (Default)
Open	BMC and PCH I ² C/SCI for VRM support

4.5 LED Indicators

BMC LAN LEDs

A dedicated BMC LAN connection is provided on the I/O riser connector (JSLOT1) by the mezzanine board. The Link LED indicates the speed of the connection. The other LED indicates activity.

BMC Link LED	
Color	Definition
Off	No Connection
Green	100 Mb/s
Amber	1 Gb/s



Onboard Power LED

The Onboard Power LED is located at LEDPWR on the motherboard. When this LED is on, the system power is on. Be sure to turn off the system power and unplug the power cords before removing or installing components.

BMC Heartbeat LED

A BMC Heartbeat LED is located at LEDBMC on the motherboard. When LEDBMC is blinking green, the BMC is functioning normally.

Chapter 5

Software

After the hardware has been installed, you can install the operating system, configure RAID settings and install the drivers. The OSs for this system that support GPUs are:

Supported Operating Systems	
OS	Version
Ubuntu	22.04/20.04(LTS)
SLES	15 SP4
RHEL	8.6

5.1 Driver Installation

The Supermicro website contains drivers and utilities for your system at <https://www.supermicro.com/wdl/driver>. Some of these must be installed, such as the chipset driver.

After accessing the website, go into the CDR_Images (in the parent directory of the above link) and locate the ISO file for your motherboard. Download this file to to a USB flash or media drive. (You may also use a utility to extract the ISO file if preferred.)

Another option is to go to the Supermicro website at <http://www.supermicro.com/products/>. Find the product page for your motherboard, and "Download the Latest Drivers and Utilities".

Insert the flash drive or media drive and the screenshot shown below should appear.

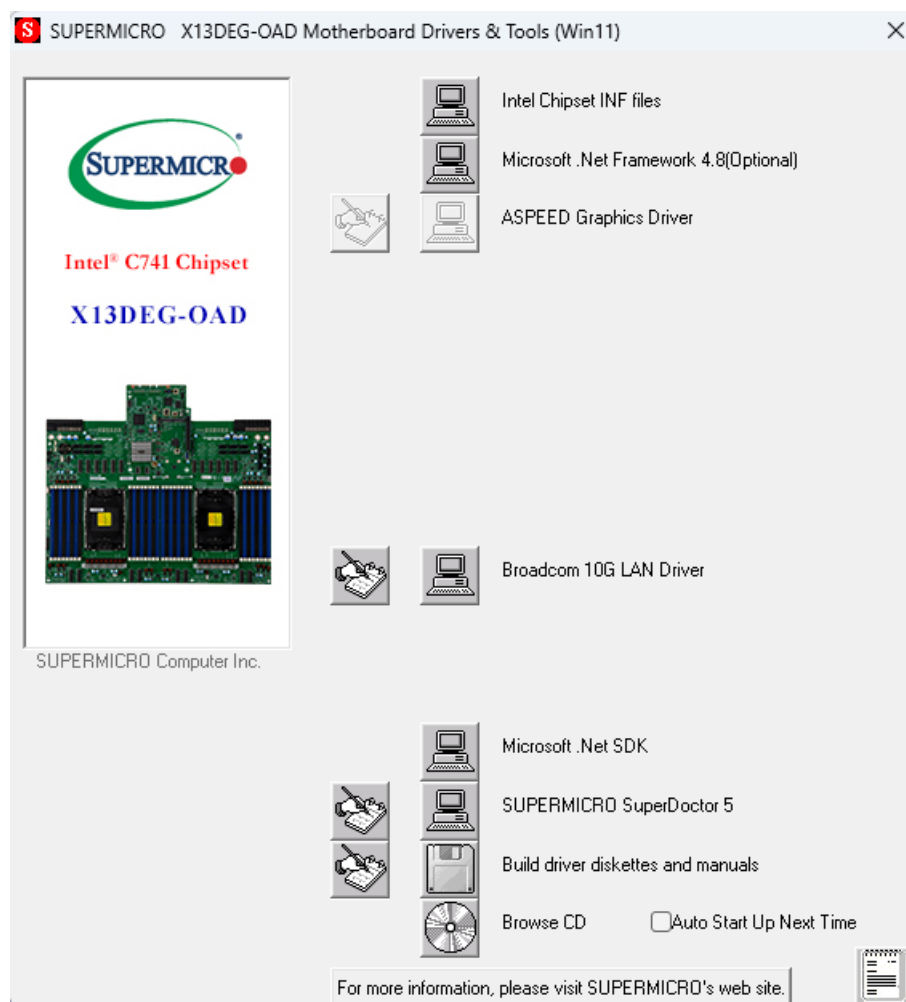

Figure 5-1. Driver & Tool Installation Screen

Note: Click the icons showing a hand writing on paper to view the readme files for each item. Click the computer icons to the right of these items to install each item (from top to the bottom) one at a time. **After installing each item, you must re-boot the system before moving on to the next item on the list.** The bottom icon with a CD on it allows you to view the entire contents.

5.2 SuperDoctor® 5

The Supermicro SuperDoctor 5 is a program that functions in a command-line or web-based interface for Windows and Linux operating systems. The program monitors such system health information as CPU temperature, system voltages, system power consumption, fan speed, and provides alerts via email or Simple Network Management Protocol (SNMP).

SuperDoctor 5 comes in local and remote management versions and can be used with Nagios to maximize your system monitoring needs. With SuperDoctor 5 Management Server (SSM Server), you can remotely control power on/off and reset chassis intrusion for multiple systems with SuperDoctor 5 or IPMI. SuperDoctor 5 Management Server monitors HTTP, FTP, and SMTP services to optimize the efficiency of your operation.

[SuperDoctor® Manual and Resources](#)

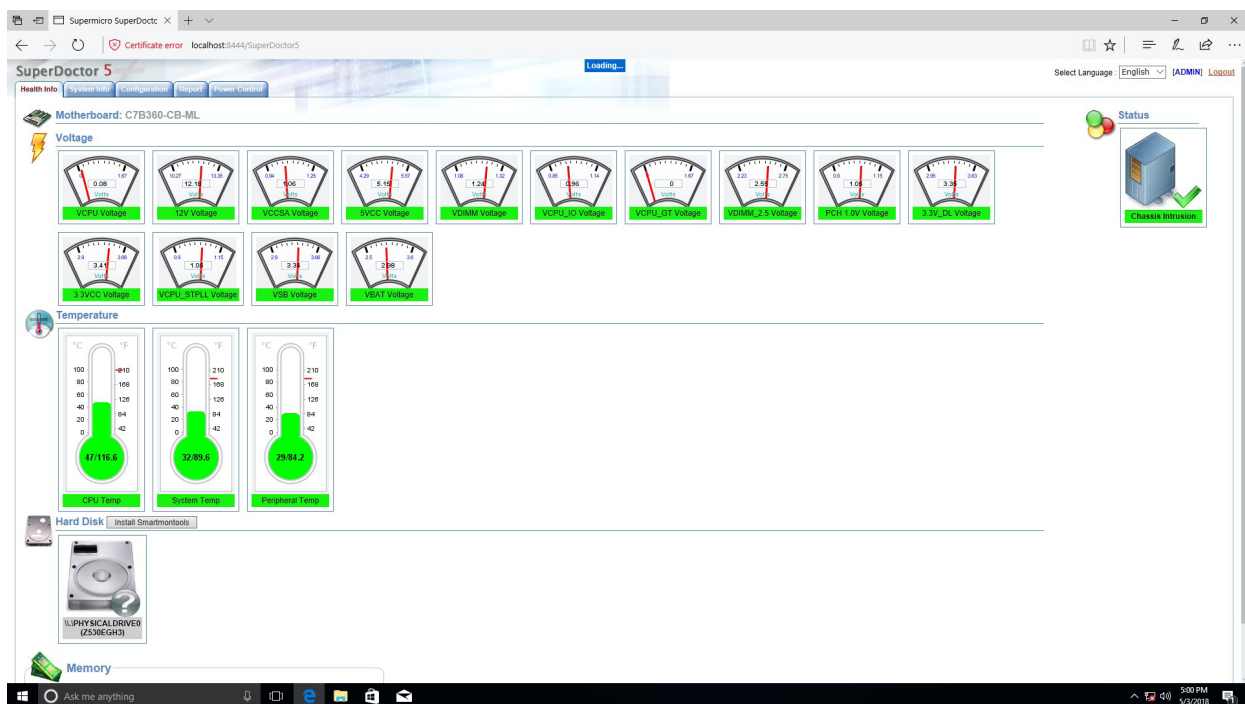

Figure 5-2. SuperDoctor 5 Interface Display Screen (Health Information)

5.3 BMC

The motherboard provides remote access, monitoring and management through the baseboard management controller (BMC) and other management controllers distributed among different system modules. There are several BIOS settings that are related to BMC. For general documentation and information on BMC, visit our website at:

www.supermicro.com/en/solutions/management-software/bmc-resources

BMC ADMIN User Password

For security, each system is assigned a unique default BMC password for the ADMIN user. This can be found on a sticker on the chassis and a sticker on the motherboard. The sticker also displays the BMC MAC address.



Figure 5-3. BMC Password Label

See Chapter 1 for the [locations](#) of the labels.

Chapter 6

Optional Components

This chapter describes optional system components and installation procedures.

6.1 Power Supply Modules

The default configuration includes six power supply modules. Two more can be added.

6.2 NIC Kit

The default configuration includes one expansion card kit (NIC Kit), which is composed of one internal side expansion card, one rear PCIe NIC riser, and supporting cables. This enables NVMe drive bays 0-11 and expansion slots 1-8 and 11-12.

A second NIC Kit is required to enable NVMe drive bays 12-15 and expansion slots 9-10.

Chapter 7

Troubleshooting and Support

7.1 Information Resources

Website

A great deal of information is available on the Supermicro website, [supermicro.com](https://www.supermicro.com).

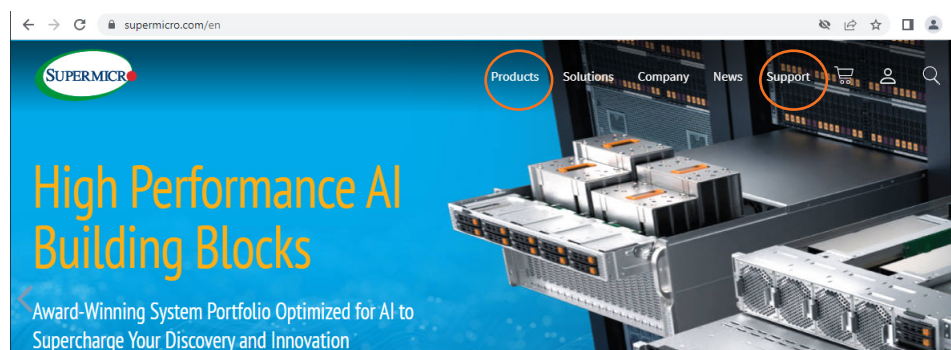

Figure 7-1. Supermicro Website

- Specifications for servers and other hardware are available by clicking the **Products** option.
- The **Support** option offers downloads (manuals, BIOS/BMC, drivers, etc.), FAQs, RMA, warranty, and other service extensions.

Direct Links for the SYS-821GV-TNR System

Web SYS-821GV-TNR [specifications page](#)

Web X13DEG-PVC [motherboard page](#) for links to the Quick Reference Guide, User Manual, validated storage drives, etc.

Direct Links for General Support and Information

[Frequently Asked Questions](#)

[Add-on card descriptions](#)

[TPM User Guide](#)

[General Memory Configuration Guide](#)

[BMC User Guide](#)

[SuperDoctor5 Large Deployment Guide](#)

Direct Links (continued)

For validated memory, use our [Product Resources page](#)

[Product Matrices](#) page for links to tables summarizing specs for systems, motherboards, power supplies, riser cards, add-on cards, etc.

[Security Center](#) for recent security notices

[Supermicro Phone and Addresses](#)

7.2 BMC Interface

The system supports a Baseboard Management Controller (BMC) interface. It provides remote access, monitoring and management. There are several BIOS settings related to the BMC.

For general documentation and information on the BMC, please visit our website at: https://www.supermicro.com/manuals/other/BMC_IPMI_X13_H13.pdf

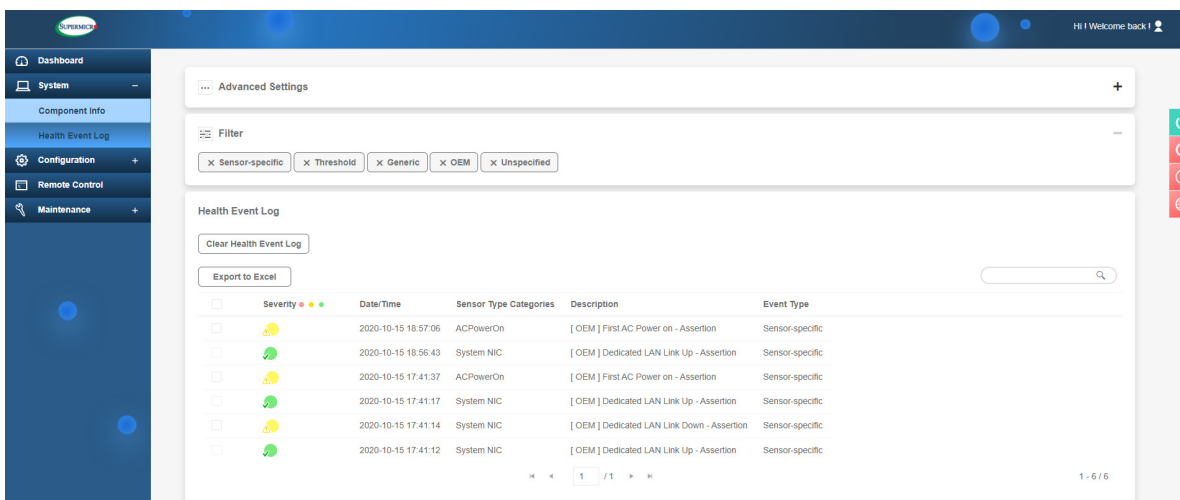

Figure 7-2. BMC Dashboard Sample

7.3 Troubleshooting Procedures

Use the following procedures to troubleshoot your system. If you have followed all of the procedures below and still need assistance, refer to the [Technical Support Procedures](#) or [Returning Merchandise for Service](#) section(s) in this chapter. [Power down](#) the system before changing any non hot-swap hardware components.

General Technique

If you experience unstable operation or get no boot response, try:

1. With power off, remove all but one DIMM and other added components, such as add-on cards, from the motherboard. Make sure the motherboard is not shorted to the chassis.
2. Set all jumpers to their default positions.
3. Power up. If the system boots, check for memory errors and add-on card problems

No Power

- Check that the power LED on the motherboard is on.

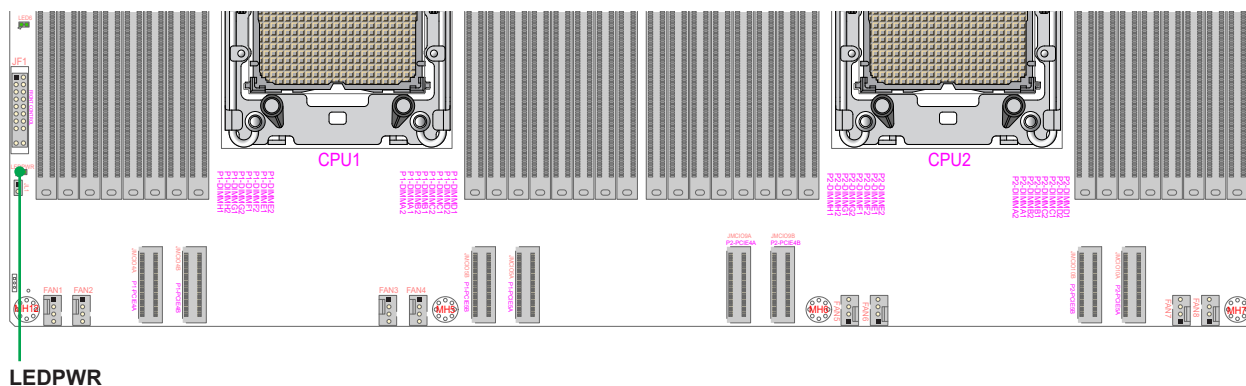

Figure 7-3. Location of the MB Power LED

- Make sure that the power connector is connected to the power supply.
- Check that the motherboard battery still supplies approximately 3 VDC. If it does not, replace it.
- Check that the system input voltage is 200-240 v.
- Turn the power switch on and off to test the system

No Video

If the power is on but you have no video, remove all add-on cards and cables.

System Boot Failure

If the system does not display Power-On-Self-Test (POST) or does not respond after the power is turned on, try the following:

- Turn on the system with only one DIMM module installed. If the system boots, check for bad DIMM modules or slots by following the Memory Errors Troubleshooting procedure below.

Memory Errors

- Make sure that the DIMM modules are properly and fully installed.
- Confirm that you are using the correct memory. Also, it is recommended that you use the same memory type and speed for all DIMMs in the system. See [Section 3.4](#) for memory details.
- Check for bad DIMM modules or slots by swapping modules between slots and noting the results.

Losing the System Setup Configuration

- Always replace power supplies with the exact same model that came with the system. A poor quality power supply may cause the system to lose the CMOS setup configuration.
- Check that the motherboard battery still supplies approximately 3 VDC. If it does not, replace it.

If the above steps do not fix the setup configuration problem, contact your vendor for repairs.

When the System Becomes Unstable

If the system becomes unstable during or after OS installation, check the following:

- CPU/BIOS support: Make sure that your CPU is supported and that you have the latest BIOS installed in your system.
- Memory: Make sure that the memory modules are supported. Refer to the [product page](#) on our website at www.supernmicro.com. Test the modules using **memtest86** or a similar utility.
- Storage drives: Make sure that all drives work properly. Replace if necessary.
- System cooling: Check that all heatsink fans and system fans work properly. Check the hardware monitoring settings in the BMC to make sure that the CPU and system temperatures are within the normal range. Also check the Control panel Overheat LED.

- Adequate power supply: Make sure that the power supply provides adequate power to the system. Make sure that all power connectors are connected. Refer to the Supermicro website for the minimum power requirements.
- Proper software support: Make sure that the correct drivers are used.

If the system becomes unstable before or during OS installation, check the following:

- Source of installation: Make sure that the devices used for installation are working properly, including boot devices.
- Cable connection: Check to make sure that all cables are connected and working properly.
- Use the minimum configuration for troubleshooting: Remove all unnecessary components (starting with add-on cards first), and use the minimum configuration (but with a CPU and a memory module installed) to identify the trouble areas.
- Identify a bad component by isolating it. Check and change one component at a time.
 - Remove a component in question from the chassis, and test it in isolation. Replace it if necessary.
 - Or swap in a new component for the suspect one.
 - Or install the possibly defective component into a known good system. If the new system works, the component is likely not the cause or the problem.

7.4 BIOS Error Beep (POST) Codes

During the POST (Power-On Self-Test) routines, which are performed each time the system is powered on, errors may occur.

Non-fatal errors are those which, in most cases, allow the system to continue the boot-up process. The error messages normally appear on the screen.

Fatal errors are those which will not allow the system to continue the boot-up procedure. If a fatal error occurs, you should consult with your system manufacturer for possible repairs.

These fatal errors are usually communicated through a series of audible beeps. The table below lists some common errors and their corresponding beep codes encountered by users.

BIOS Error Beep (POST) Codes		
Beep Code	Error Message	Description
1 short	Refresh	Circuits have been reset (Ready to power up)
5 short, 1 long	Memory error	No memory detected in system
5 long, 2 short	Display memory read/write error	Video adapter missing or with faulty memory
1 long continuous	System OH	System overheat condition

Additional BIOS POST Codes

The AMI BIOS supplies additional checkpoint codes, which are documented online at <http://www.supermicro.com/support/manuals/> ("AMI BIOS POST Codes User's Guide").

When BIOS performs the Power On Self Test, it writes checkpoint codes to I/O port 0080h. If the computer cannot complete the boot process, a diagnostic card can be attached to the computer to read I/O port 0080h (Supermicro p/n AOC-LPC80-20).

For information on AMI updates, please refer to <http://www.ami.com/products/>.

7.5 Crash Dump Using the BMC Dashboard

In the event of a processor internal error (IERR) that crashes your system, you may want to provide information to support staff. You can download a crash dump of status information using the BMC Dashboard. The BMC manual is available at https://www.supermicro.com/manuals/other/BMC_IPMI_X13_H13.pdf.

Check Error Log

1. Access the BMC web interface.
2. Click the **Server Health** tab, then **Event Log** to verify an IERR error.

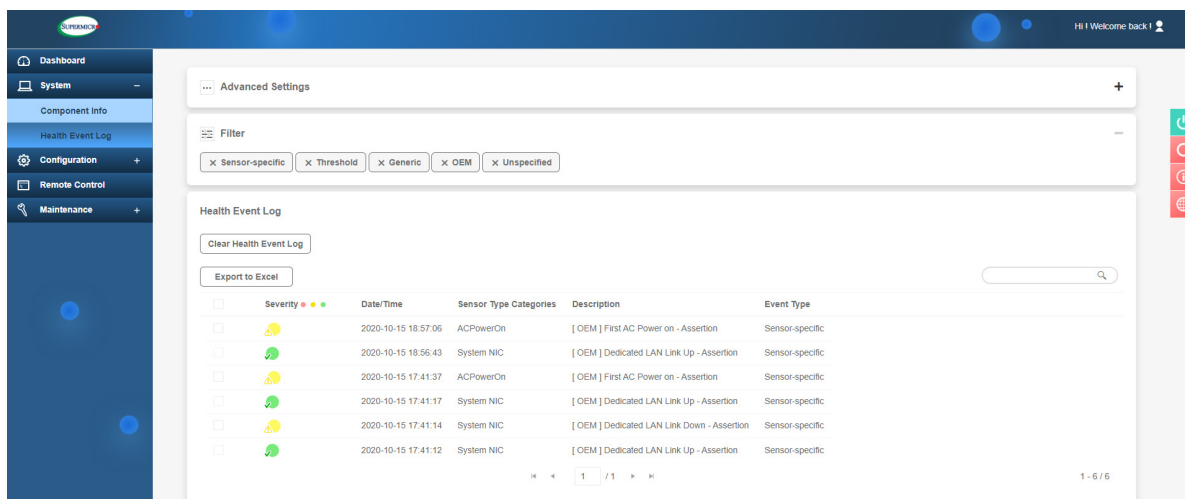

Figure 7-4. BMC Event Log

In the event of an IERR, the BMC executes a crash dump. You must download the crash dump and save it.

7.6 UEFI BIOS Recovery

Warning: Do not upgrade the BIOS unless your system has a BIOS-related issue. Flashing the wrong BIOS can cause irreparable damage to the system. In no event shall Supermicro be liable for direct, indirect, special, incidental, or consequential damages arising from a BIOS update. If you do update the BIOS, do not shut down or reset the system while the BIOS is updating to avoid possible boot failure.

Overview

The Unified Extensible Firmware Interface (UEFI) provides a software-based interface between the operating system and the platform firmware in the pre-boot environment. The UEFI specification supports an architecture-independent mechanism that will allow the UEFI OS loader stored in an add-on card to boot the system. The UEFI offers clean, hands-off management to a computer during system boot.

Recovering the UEFI BIOS Image

A UEFI BIOS flash chip consists of a recovery BIOS block and a main BIOS block (a main BIOS image). The recovery block contains critical BIOS codes, including memory detection and recovery codes for the user to flash a healthy BIOS image if the original main BIOS image is corrupted. When the system power is turned on, the recovery block codes execute first. Once this process is complete, the main BIOS code will continue with system initialization and the remaining POST (Power-On Self-Test) routines.

Note 1: Follow the BIOS recovery instructions below for BIOS recovery when the main BIOS block crashes.

Note 2: When the BIOS recovery block crashes, you will need to follow the procedures to make a Returned Merchandise Authorization (RMA) request. Also, you may use the Supermicro Update Manager (SUM) Out-of-Band (https://www.supermicro.com.tw/products/nfo/SMS_SUM.cfm) to reflash the BIOS.

Recovering the Main BIOS Block with a USB Device

This feature allows the user to recover the main BIOS image using a USB-attached device without additional utilities used. A USB flash device such as a USB Flash Drive, or a USB CD/DVD ROM/RW device can be used for this purpose. However, a USB storage drive cannot be used for BIOS recovery at this time.

The file system supported by the recovery block is FAT (including FAT12, FAT16, and FAT32) which is installed on a bootable or non-bootable USB-attached device. However, the BIOS might need several minutes to locate the SUPER.ROM file if the media size becomes too large due to the huge volumes of folders and files stored in the device.

To perform UEFI BIOS recovery using a USB-attached device, follow the instructions below.

1. Using a different machine, copy the "Super.ROM" binary image file into the Root "\\" directory of a USB device or a writable CD/DVD.

Note 1: If you cannot locate the "Super.ROM" file in your drive, visit our website at www.supermicro.com to download the BIOS package. Extract the BIOS binary image into a USB flash device and rename it "Super.ROM" for the BIOS recovery use.

Note 2: Before recovering the main BIOS image, confirm that the "Super.ROM" binary image file you download is the same version or a close version meant for your motherboard.

2. Insert the USB device that contains the new BIOS image ("Super.ROM") into your USB drive and reset the system when the following screen appears.
3. After locating the healthy BIOS binary image, the system will enter the BIOS Recovery menu as shown below.



Note: At this point, you may decide if you want to start the BIOS recovery. If you decide to proceed with BIOS recovery, follow the procedures below.

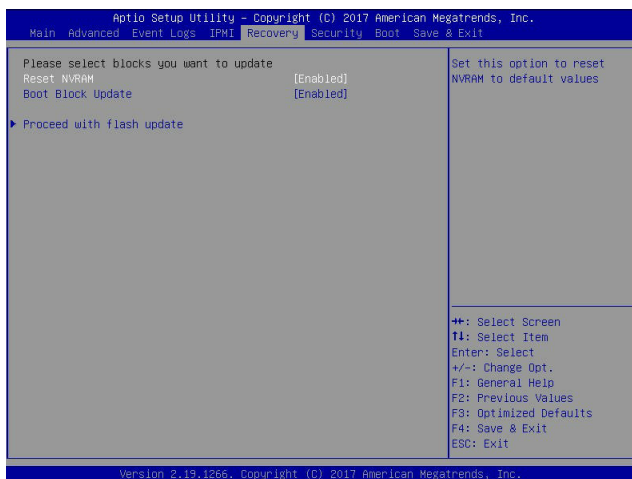

4. When the screen as shown above displays, use the arrow keys to select the item "Proceed with flash update" and press the <Enter> key. You will see the BIOS recovery progress as shown in the screen below.

Note: Do not interrupt the BIOS flashing process until it has completed.

5. After the BIOS recovery process is complete, press any key to reboot the system.
6. Using a different system, extract the BIOS package into a USB flash drive.

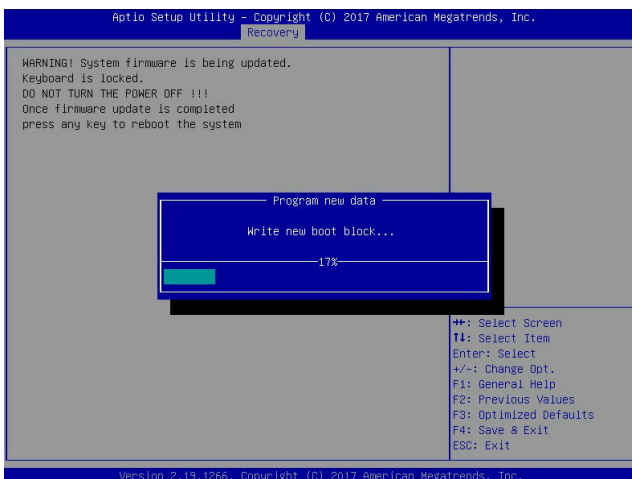

7. Press continuously during system boot to enter the BIOS Setup utility. From the top of the tool bar, select Boot to enter the submenu. From the submenu list, select Boot

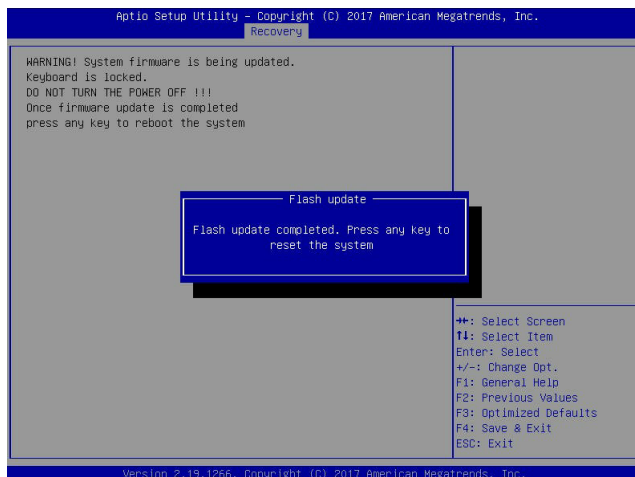

Option #1 as shown below. Then, set Boot Option #1 to [UEFI AP:UEFI: Built-in EFI Shell]. Press <F4> to save the settings and exit the BIOS Setup utility.

8. When the UEFI Shell prompt appears, type fs# to change the device directory path. Go to the directory that contains the BIOS package you extracted earlier from Step 6. Enter flash.nsh BIOSname.### at the prompt to start the BIOS update process.

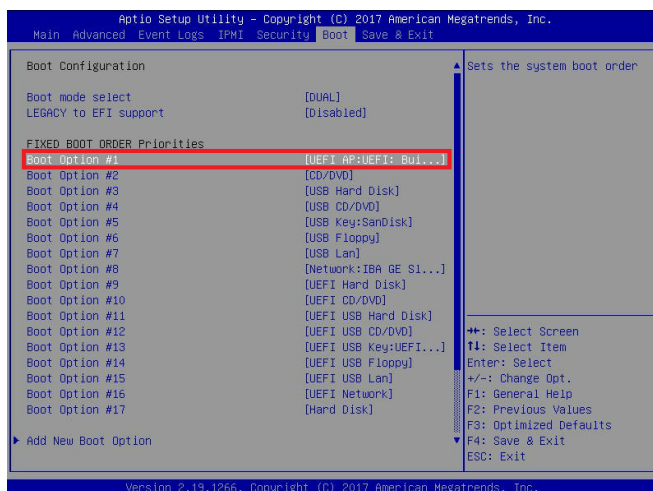

Note: *Do not interrupt this process* until the BIOS flashing is complete.

```

UEFI Interactive Shell v2.1
EDK II
UEFI v2.50 (American Megatrends, 0x0005000C)
Mapping table
  FS0: Alias(s):HD0:0B:BLK1:
        PciRoot(0x0)/Pci(0x14,0x0)/USB(0x11,0x0)/HD(1,MBR,0x37901D72,0x800,0x1
CR9592)
  BLK0: Alias(s):
        PciRoot(0x0)/Pci(0x14,0x0)/USB(0x11,0x0)
Press F8 in 1 seconds to skip startup.nsh or any other key to continue.
Shell: fs0:
FS0:\> cd \AFUDOS
FS0:\AFUDOS> cd SNIJPM2_03162017
FS0:\AFUDOS\SNIJPM2_03162017> flash.nsh X110PU7_314

```

9. The screen above indicates that the BIOS update process is complete. When you see the screen above, unplug the AC power cable from the power supply, clear CMOS, and plug

```

Done.
[ Access Cmos Port Ex ]
<Read>
Index 0x51: 0x10

Done.
*****
*
* Program BIOS and ME (including FDT) regions...
*
*****
| AMT Firmware Update Utility v5.09.01.1917 |
| Copyright (C)2017 American Megatrends Inc. All Rights Reserved. |
*****
CPUID = 50652

Reading flash ..... done
- ME Data Size checking - ok
- FFS checksums ..... ok
- Check RomLayout ..... Ok
Erasing Boot Block ..... done
Updating Boot Block ..... done
Verifying Boot Block ..... done
_Erasing Main Block ..... 0x00132000 (0x)

```

the AC power cable in the power supply again to power on the system.

10. Press continuously to enter the BIOS Setup utility.

```

Verifying NDB Block ..... done
- Update success for FDR
- Update success for IE
- Successful Update Recovery Loader to OPRx11
- Successful Update MFSB11
- Successful Update FPR11
- Successful Update MFS, IVBI and IVB211
- Successful Update FLOG and UTDK11
- ME Entire Image update success !!
WARNING : System must power-off to have the changes take effect!
Moving F80:\AFUDOS\SNIJPM2_03162017\Fdtv64.efi -> F80:\AFUDOS\SNIJPM2_03162017\
d1.smc
- [ok]
Moving F80:\AFUDOS\SNIJPM2_03162017\Fuef1x64.efi -> F80:\AFUDOS\SNIJPM2_0316201
7\Fuef1.smc
- [ok]
*****
* Please ignore this 'Shell: Cannot read from file - Device Error'
* warning message due to it does not impact flashing process.
*
*****
Deleting "F:\SetupRom"
Delete successful.
FS0:\>

```

11. Press <F3> to load the default settings.
12. After loading the default settings, press <F4> to save the settings and exit the BIOS Setup utility.

7.7 CMOS Clear

JBT1 is used to clear CMOS, which will also clear any passwords. Instead of pins, this jumper consists of contact pads to prevent accidentally clearing the contents of CMOS.

To Clear CMOS

1. First [power down](#) the system completely.
2. Remove the cover of the chassis to access the motherboard.
3. [Remove the onboard battery](#) from the motherboard.
4. Short the CMOS pads with a metal object such as a small screwdriver for at least four seconds.
5. Remove the screwdriver or shorting device.
6. Replace the onboard battery and chassis cover, and reconnect the power cords, then power on the system.



Notes: Clearing CMOS will also clear all passwords.

Do not use the PW_ON connector to clear CMOS.

7.8 BMC Reset

The BMC can be reset using the UID button.

- Reset – Press and hold the UID button. After six seconds, the LED blinks at 2Hz. The BMC resets and the reset duration is ~250 ms. Then the BMC starts to boot.
- Restore factory default configuration – Hold the UID button for twelve seconds. The LED blinks at 4Hz while defaults are configured. **Note:** All BMC settings including username and password will be removed except the FRU and network settings.

Firmware update – When the BMC firmware is being updated, the UID LED blinks at 10Hz.

BMC Reset Options		
Event	UID LED	BMC Heartbeat LED
Reset	Blue, Blinks at 2Hz	Green, solid
Restore Defaults	Blue, Blinks at 4Hz	Off
Update	Blue, Blinks at 10Hz	

7.9 Where to Get Replacement Components

If you need replacement parts for your system, to ensure the highest level of professional service and technical support, purchase exclusively from our Supermicro Authorized Distributors/System Integrators/Resellers. A list can be found at: <http://www.supermicro.com>. Click the "Where to Buy" tab.

7.10 Reporting an Issue

Technical Support Procedures

Before contacting Technical Support, please take the following steps. If your system was purchased through a distributor or reseller, please contact them for troubleshooting services. They have the best knowledge of your specific system configuration.

1. Please review the [Troubleshooting Procedures](#) in this manual and [Frequently Asked Questions](#) on our website before contacting Technical Support.
2. BIOS upgrades can be downloaded from our website. **Note:** Not all BIOS can be flashed depending on the modifications to the boot block code.
3. If you still cannot resolve the problem, include the following information when contacting us for technical support:
 - System, motherboard, and chassis model numbers and PCB revision number
 - BIOS release date/version (this can be seen on the initial display when your system first boots up)
 - System configuration

An example of a Technical Support form is posted on our [website](#). Distributors: For immediate assistance, please have your account number ready when contacting our technical support department by email.

Returning Merchandise for Service

A receipt or copy of your invoice marked with the date of purchase is required before any warranty service will be rendered. You can obtain service by calling your vendor for a Returned Merchandise Authorization (RMA) number. When returning to the manufacturer, the RMA number should be prominently displayed on the outside of the shipping carton, and mailed prepaid or hand-carried. Shipping and handling charges will be applied for all orders that must be mailed when service is complete.

For faster service, RMA authorizations may be requested online (<http://www.supermicro.com/support/rma/>).

Whenever possible, repack the chassis in the original Supermicro carton, using the original packaging material. If these are no longer available, be sure to pack the chassis securely, using packaging material to surround the chassis so that it does not shift within the carton and become damaged during shipping.

This warranty only covers normal consumer use and does not cover damages incurred in shipping or from failure due to the alteration, misuse, abuse or improper maintenance of products.

During the warranty period, contact your distributor first for any product problems.

Vendor Support Filing System

For issues related to Intel, use the Intel IPS filing system:

<https://www.intel.com/content/www/us/en/design/support/ips/training/welcome.html>

For issues related to Red Hat Enterprise Linux, since it is a subscription based OS, contact your account representative.

7.11 Feedback

Supermicro values your feedback as we strive to improve our customer experience in all facets of our business. Please email us at techwriterteam@supermicro.com to provide feedback on our manuals.

7.12 Contacting Supermicro

Headquarters

Address: Super Micro Computer, Inc.
980 Rock Ave.
San Jose, CA 95131 U.S.A.

Tel: +1 (408) 503-8000

Fax: +1 (408) 503-8008

Email: marketing@supermicro.com (General Information)
Sales-USA@supermicro.com (Sales Inquiries)
Government_Sales-USA@supermicro.com (Gov. Sales Inquiries)
support@supermicro.com (Technical Support)
RMA@supermicro.com (RMA Support)
Webmaster@supermicro.com (Webmaster)

Website: www.supermicro.com

Europe

Address: Super Micro Computer B.V.
Het Sterrenbeeld 28, 5215 ML
's-Hertogenbosch, The Netherlands

Tel: +31 (0) 73-6400390

Fax: +31 (0) 73-6416525

Email: Sales_Europe@supermicro.com (Sales Inquiries)
Support_Europe@supermicro.com (Technical Support)
RMA_Europe@supermicro.com (RMA Support)

Website: www.supermicro.nl

Asia-Pacific

Address: Super Micro Computer, Inc.
3F, No. 150, Jian 1st Rd.
Zhonghe Dist., New Taipei City 235
Taiwan (R.O.C)

Tel: +886-(2) 8226-3990

Fax: +886-(2) 8226-3992

Email: Sales-Asia@supermicro.com.tw (Sales Inquiries)
Support@supermicro.com.tw (Technical Support)
RMA@supermicro.com.tw (RMA Support)

Website: www.supermicro.com.tw

Appendix A

Standardized Warning Statements for AC Systems

About Standardized Warning Statements

The following statements are industry standard warnings, provided to warn the user of situations which have the potential for bodily injury. Should you have questions or experience difficulty, contact Supermicro's Technical Support department for assistance. Only certified technicians should attempt to install or configure components.

Read this appendix in its entirety before installing or configuring components in the Supermicro chassis.

These warnings may also be found on our website at http://www.supermicro.com/about/policies/safety_information.cfm.

Warning Definition



Warning! This warning symbol means danger. You are in a situation that could cause bodily injury. Before you work on any equipment, be aware of the hazards involved with electrical circuitry and be familiar with standard practices for preventing accidents.

警告の定義

この警告サインは危険を意味します。

人身事故につながる可能性がありますので、いずれの機器でも動作させる前に、電気回路に含まれる危険性に注意して、標準的な事故防止策に精通して下さい。

此警告符号代表危險。

您正处于可能受到严重伤害的工作环境中。在您使用设备开始工作之前，必须充分意识到触电的危险，并熟练掌握防止事故发生的标准工作程序。请根据每项警告结尾的声明号码找到此设备的安全性警告说明的翻译文本。

此警告符號代表危險。

您正處於可能身體可能會受損傷的工作環境中。在您使用任何設備之前，請注意觸電的危險，並且要熟悉預防事故發生的標準工作程序。請依照每一注意事項後的號碼找到相關的翻譯說明內容。

Warnung

WICHTIGE SICHERHEITSHINWEISE

Dieses Warnsymbol bedeutet Gefahr. Sie befinden sich in einer Situation, die zu Verletzungen führen kann. Machen Sie sich vor der Arbeit mit Geräten mit den Gefahren elektrischer Schaltungen und den üblichen Verfahren zur Vorbeugung vor Unfällen vertraut. Suchen Sie mit der am Ende jeder Warnung angegebenen Anweisungsnummer nach der jeweiligen Übersetzung in den übersetzten Sicherheitshinweisen, die zusammen mit diesem Gerät ausgeliefert wurden.

BEWAHREN SIE DIESE HINWEISE GUT AUF.

INSTRUCCIONES IMPORTANTES DE SEGURIDAD

Este símbolo de aviso indica peligro. Existe riesgo para su integridad física. Antes de manipular cualquier equipo, considere los riesgos de la corriente eléctrica y familiarícese con los procedimientos estándar de prevención de accidentes. Al final de cada advertencia encontrará el número que le ayudará a encontrar el texto traducido en el apartado de traducciones que acompaña a este dispositivo.

GUARDE ESTAS INSTRUCCIONES.

IMPORTANTES INFORMATIONS DE SÉCURITÉ

Ce symbole d'avertissement indique un danger. Vous vous trouvez dans une situation pouvant entraîner des blessures ou des dommages corporels. Avant de travailler sur un équipement, soyez conscient des dangers liés aux circuits électriques et familiarisez-vous avec les procédures couramment utilisées pour éviter les accidents. Pour prendre connaissance des traductions des avertissements figurant dans les consignes de sécurité traduites qui accompagnent cet appareil, référez-vous au numéro de l'instruction situé à la fin de chaque avertissement.

CONSERVEZ CES INFORMATIONS.

תקנון הזהרות אזהרה

הזהרות הבאות הן אזהרות על פי תקני התעשייה, על מנת להזהיר את המשתמש מפני חבלה פיזית אפשרית. במידה ויש שאלות או היתקלות בבעיה כלשהי, יש ליצור קשר עם מחלקת תמיכה טכנית של סופרמיקרו. טכנאים מוסמכים בלבד רשאים להתקין או להגדיר את הרכיבים. יש לקרוא את הנספח במלואו לפני התקנת או הגדרת הרכיבים במארזי סופרמיקרו.

اَكْ ف حالة وُكِي اَي تتسبب ف اصابة جسدهُ هذا الزهز عُ خطر! تحذُرُ .
 قبل اَي تعول على اَي هعدات، كي على علن بالوخاطز ال اُجوة عي الذوائر
 الكهزبائِة
 وكي على دراةُ بالووارسات النقاىِة لو عُ وقع اَي حادث
 استخدم رقن الب اى الو صُص ف هاةُ كل تحذُرُ للعشر تزجوتها

안전을 위한 주의사항

경고!

이 경고 기호는 위험이 있음을 알려 줍니다. 작업자의 신체에 부상을 야기 할 수 있는 상태에 있게 됩니다. 모든 장비에 대한 작업을 수행하기 전에 전기회로와 관련된 위험요소들을 확인하시고 사전에 사고를 방지할 수 있도록 표준 작업절차를 준수해 주시기 바랍니다.

해당 번역문을 찾기 위해 각 경고의 마지막 부분에 제공된 경고문 번호를 참조하십시오

BELANGRIJKE VEILIGHEIDSINSTRUCTIES

Dit waarschuwings symbool betekent gevaar. U verkeert in een situatie die lichamelijk letsel kan veroorzaken. Voordat u aan enige apparatuur gaat werken, dient u zich bewust te zijn van de bij een elektrische installatie betrokken risico's en dient u op de hoogte te zijn van de standaard procedures om ongelukken te voorkomen. Gebruik de nummers aan het eind van elke waarschuwing om deze te herleiden naar de desbetreffende locatie.

BEWAAR DEZE INSTRUCTIES

Installation Instructions



Warning! Read the installation instructions before connecting the system to the power source.

設置手順書

システムを電源に接続する前に、設置手順書をお読み下さい。

警告

将此系统连接电源前,请先阅读安装说明。

警告

將系統與電源連接前，請先閱讀安裝說明。

Warnung

Vor dem Anschließen des Systems an die Stromquelle die Installationsanweisungen lesen.

¡Advertencia!

Lea las instrucciones de instalación antes de conectar el sistema a la red de alimentación.

Attention

Avant de brancher le système sur la source d'alimentation, consulter les directives d'installation.

יש לקרוא את הוראות התקנה לפני חיבור המערכת למקור מתח.

اقرأ إرشادات التركيب قبل توصيل النظام إلى مصدر للطاقة

시스템을 전원에 연결하기 전에 설치 안내를 읽어주십시오.

Waarschuwing

Raadpleeg de installatie-instructies voordat u het systeem op de voedingsbron aansluit.

Circuit Breaker

Warning! This product relies on the building's installation for short-circuit (overcurrent) protection. Ensure that the protective device is rated not greater than: 250 V, 20 A.

サーキット・ブレーカー

この製品は、短絡(過電流)保護装置がある建物での設置を前提としています。

保護装置の定格が250 V、20 Aを超えないことを確認下さい。

警告

此产品的短路(过载电流)保护由建筑物的供电系统提供,确保短路保护设备的额定电流不大于250V,20A。

警告

此產品的短路(過載電流)保護由建築物的供電系統提供,確保短路保護設備的額定電流不大於250V,20A。

Warnung

Dieses Produkt ist darauf angewiesen, dass im Gebäude ein Kurzschluss- bzw. Überstromschutz installiert ist. Stellen Sie sicher, dass der Nennwert der Schutzvorrichtung nicht mehr als: 250 V, 20 A beträgt.

¡Advertencia!

Este equipo utiliza el sistema de protección contra cortocircuitos (o sobrecorrientes) del edificio. Asegúrese de que el dispositivo de protección no sea superior a: 250 V, 20 A.

Attention

Pour ce qui est de la protection contre les courts-circuits (surtension), ce produit dépend de l'installation électrique du local. Vérifiez que le courant nominal du dispositif de protection n'est pas supérieur à :250 V, 20 A.

מוצר זה מסתמך על הגנה המותקנת במבנים למניעת קצר חשמלי. יש לוודא כי המכשיר המגן מפני הקצר החשמלי הוא לא יותר מ-250VDC, 20A

هذا المنتج يعتمد على معدات الحماية مه الدوائر القصيرة التي تم تثبيتها في المبنى
تأكد من أن تقييم الجهاز الوقائي ليس أكثر من : 20A, 250V

경고!

이 제품은 전원의 단락(과전류)방지에 대해서 전적으로 건물의 관련 설비에 의존합니다. 보호장치의 정격이 반드시 250V(볼트), 20A(암페어)를 초과하지 않도록 해야 합니다.

Waarschuwing

Dit product is afhankelijk van de kortsluitbeveiliging (overspanning) van uw elektrische installatie. Controleer of het beveiligde apparaat niet groter gedimensioneerd is dan 250V, 20A.

Power Disconnection Warning



Warning! The system must be disconnected from all sources of power and the power cord removed from the power supply module(s) before accessing the chassis interior to install or remove system components.



電源切断の警告

システムコンポーネントの取り付けまたは取り外しのために、シャーシ内部にアクセスするには、システムの電源はすべてのソースから切断され、電源コードは電源モジュールから取り外す必要があります。

警告

在你打开机箱并安装或移除内部器件前,必须将系统完全断电,并移除电源线。

警告

在您打開機殼安裝或移除內部元件前，必須將系統完全斷電，並移除電源線。

Warnung

Das System muss von allen Quellen der Energie und vom Netzanschlusskabel getrennt sein, das von den Spg.Versorgungsteilmodulen entfernt wird, bevor es auf den Chassisinnenraum zurückgreift, um Systemsbestandteile anzubringen oder zu entfernen.

¡Advertencia!

El sistema debe ser disconnected de todas las fuentes de energía y del cable eléctrico quitado de los módulos de fuente de alimentación antes de tener acceso el interior del chasis para instalar o para quitar componentes de sistema.

Attention

Le système doit être débranché de toutes les sources de puissance ainsi que de son cordon d'alimentation secteur avant d'accéder à l'intérieur du chasis pour installer ou enlever des composants de système.

אזהרה מפני ניתוק חשמלי

אזהרה!

יש לנתק את המערכת מכל מקורות החשמל ויש להסיר את כבל החשמלי מהספק לפני גישה לחלק הפנימי של המארז לצורך התקנת או הסרת רכיבים.

يجب فصل انظاو من جميع مصادر انطاقت وإزانت سهك انكهرباء من وحدة امداد انطاقت قيم

انصل إلى امناطق انداخهيت نههيكم نتشيج أو إزانت مكناث الجهاز

경고!

시스템에 부품들을 장착하거나 제거하기 위해서는 새시 내부에 접근하기 전에 반드시 전원 공급장치로부터 연결되어있는 모든 전원과 전기코드를 분리해주어야 합니다.

Waarschuwing

Voordat u toegang neemt tot het binnenwerk van de behuizing voor het installeren of verwijderen van systeem onderdelen, dient u alle spanningsbronnen en alle stroomkabels aangesloten op de voeding(en) van de behuizing te verwijderen

Equipment Installation



Warning! Only trained and qualified personnel should be allowed to install, replace, or service this equipment.

機器の設置

トレーニングを受け認定された人だけがこの装置の設置、交換、またはサービスを許可されています。

警告

只有经过培训且具有资格的人员才能进行此设备的安装、更换和维修。

警告

只有經過受訓且具資格人員才可安裝、更換與維修此設備。

Warnung

Das Installieren, Ersetzen oder Bedienen dieser Ausrüstung sollte nur geschultem, qualifiziertem Personal gestattet werden.

¡Advertencia!

Solamente el personal calificado debe instalar, reemplazar o utilizar este equipo.

Attention

Il est vivement recommandé de confier l'installation, le remplacement et la maintenance de ces équipements à des personnels qualifiés et expérimentés.

אזהרה!

צוות מוסמך בלבד רשאי להתקין, להחליף את הציוד או לתת שירות עבור הציוד.

والمدربيه لتزكيب واستبدال أو خدمة هذا الجهاز يجب أن يسمح فقط للمظفيه المؤهليه

경고!

훈련을 받고 공인된 기술자만이 이 장비의 설치, 교체 또는 서비스를 수행할 수 있습니다.

Waarschuwing

Deze apparatuur mag alleen worden geïnstalleerd, vervangen of hersteld door geschoold en gekwalificeerd personeel.

Restricted Area



Warning! This unit is intended for installation in restricted access areas. A restricted access area can be accessed only through the use of a special tool, lock and key, or other means of security. (This warning does not apply to workstations).

アクセス制限区域

このユニットは、アクセス制限区域に設置されることを想定しています。

アクセス制限区域は、特別なツール、鍵と錠前、その他のセキュリティの手段を用いてのみ出入りが可能です。

警告

此部件应安装在限制进出的场所，限制进出的场所指只能通过使用特殊工具、锁和钥匙或其它安全手段进出的场所。

警告

此裝置僅限安裝於進出管制區域，進出管制區域係指僅能以特殊工具、鎖頭及鑰匙或其他安全方式才能進入的區域。

Warnung

Diese Einheit ist zur Installation in Bereichen mit beschränktem Zutritt vorgesehen. Der Zutritt zu derartigen Bereichen ist nur mit einem Spezialwerkzeug, Schloss und Schlüssel oder einer sonstigen Sicherheitsvorkehrung möglich.

¡Advertencia!

Esta unidad ha sido diseñada para instalación en áreas de acceso restringido. Sólo puede obtenerse acceso a una de estas áreas mediante la utilización de una herramienta especial, cerradura con llave u otro medio de seguridad.

Attention

Cet appareil doit être installée dans des zones d'accès réservés. L'accès à une zone d'accès réservé n'est possible qu'en utilisant un outil spécial, un mécanisme de verrouillage et une clé, ou tout autre moyen de sécurité.

אזור עם גישה מוגבלת

אזהרה!

יש להתקין את היחידה באזורים שיש בהם הגבלת גישה. הגישה ניתנת בעזרת 'כלי אבטחה בלבד' (מפתח, מנעול וכד.).

تخصيص هذه انحدّة نترك بُها ف مناطق محظورة تم .
ممكن اننصل إن منطقت محظورة فقط من خلال استخداو أداة خاصت
أو أ وس هُت أخري نلالأمما ققم ومفتاح

경고!

이 장치는 접근이 제한된 구역에 설치하도록 되어있습니다. 특수도구, 잠금 장치 및 키, 또는 기타 보안 수단을 통해서만 접근 제한 구역에 들어갈 수 있습니다.

Waarschuwing

Dit apparaat is bedoeld voor installatie in gebieden met een beperkte toegang. Toegang tot dergelijke gebieden kunnen alleen verkregen worden door gebruik te maken van speciaal gereedschap, slot en sleutel of andere veiligheidsmaatregelen.

Battery Handling



Warning! There is the danger of explosion if the battery is replaced incorrectly. Replace the battery only with the same or equivalent type recommended by the manufacturer. Dispose of used batteries according to the manufacturer's instructions

電池の取り扱い

電池交換が正しく行われなかった場合、破裂の危険性があります。交換する電池はメーカーが推奨する型、または同等のものを使用下さい。使用済電池は製造元の指示に従って処分して下さい。

警告

電池更換不當會有爆炸危險。請只使用同類電池或製造商推薦的功能相當的電池更換原有電池。請按製造商的說明處理廢舊電池。

警告

電池更換不當會有爆炸危險。請使用製造商建議之相同或功能相當的電池更換原有電池。請按照製造商的說明指示處理廢棄舊電池。

Warnung

Bei Einsetzen einer falschen Batterie besteht Explosionsgefahr. Ersetzen Sie die Batterie nur durch den gleichen oder vom Hersteller empfohlenen Batterietyp. Entsorgen Sie die benutzten Batterien nach den Anweisungen des Herstellers.

Attention

Danger d'explosion si la pile n'est pas remplacée correctement. Ne la remplacer que par une pile de type semblable ou équivalent, recommandée par le fabricant. Jeter les piles usagées conformément aux instructions du fabricant.

¡Advertencia!

Existe peligro de explosión si la batería se reemplaza de manera incorrecta. Reemplazar la batería exclusivamente con el mismo tipo o el equivalente recomendado por el fabricante. Desechar las baterías gastadas según las instrucciones del fabricante.

אזהרה!

קיימת סכנת פיצוץ של הסוללה במידה והוחלפה בדרך לא תקינה. יש להחליף את הסוללה בסוג התואם מחברת יצרן מומלצת. סילוק הסוללות המשומשות יש לבצע לפי הוראות היצרן.

هناك خطر من انفجار في حالة اسبدال البطارية بطريقة غير صحيحة فعلياً اسبدال البطارية فقط بنفس النوع أو ما يعادلها مما أوصت به الشركة المصنعة جخلص من البطاريات المسعملة وفقاً لتعليمات الشركة الصانعة

경고!

배터리가 올바르게 교체되지 않으면 폭발의 위험이 있습니다. 기존 배터리와 동일하거나 제조사에서 권장하는 동등한 종류의 배터리로만 교체해야 합니다. 제조사의 안내에 따라 사용된 배터리를 처리하여 주십시오.

Waarschuwing

Er is ontploffingsgevaar indien de batterij verkeerd vervangen wordt. Vervang de batterij slechts met hetzelfde of een equivalent type die door de fabrikant aanbevolen wordt. Gebruikte batterijen dienen overeenkomstig fabrieksvoorschriften afgevoerd te worden.

Redundant Power Supplies



Warning! This unit might have more than one power supply connection. All connections must be removed to de-energize the unit.

冗長電源装置

このユニットは複数の電源装置が接続されている場合があります。

ユニットの電源を切るためには、すべての接続を取り外さなければなりません。

警告

此部件连接的电源可能不止一个，必须将所有电源断开才能停止给该部件供电。

警告

此裝置連接的電源可能不只一個，必須切斷所有電源才能停止對該裝置的供電。

Warnung

Dieses Gerät kann mehr als eine Stromzufuhr haben. Um sicherzustellen, dass der Einheit kein Strom zugeführt wird, müssen alle Verbindungen entfernt werden.

¡Advertencia!

Puede que esta unidad tenga más de una conexión para fuentes de alimentación. Para cortar por completo el suministro de energía, deben desconectarse todas las conexiones.

Attention

Cette unité peut avoir plus d'une connexion d'alimentation. Pour supprimer toute tension et tout courant électrique de l'unité, toutes les connexions d'alimentation doivent être débranchées.

אם קיים יותר מספק אחד

אזהרה!

ליחידה יש יותר מחיבור אחד של ספק. יש להסיר את כל החיבורים על מנת לרוקן את היחידה.

قد يكون لهذا الجهاز عدة اتصالات بوحدات امداد الطاقة .
يجب إزالة كافة الاتصالات لعسل الوحدة عن الكهرباء

경고!

이 장치에는 한 개 이상의 전원 공급 단자가 연결되어 있을 수 있습니다. 이 장치에 전원을 차단하기 위해서는 모든 연결 단자를 제거해야만 합니다.

Waarschuwing

Deze eenheid kan meer dan één stroomtoevoeraansluiting bevatten. Alle aansluitingen dienen verwijderd te worden om het apparaat stroomloos te maken.

Backplane Voltage



Warning! Hazardous voltage or energy is present on the backplane when the system is operating. Use caution when servicing.

バックプレーンの電圧

システムの稼働中は危険な電圧または電力が、バックプレーン上にかかっています。

修理する際にはご注意ください。

警告

当系统正在进行时，背板上有很危险的电压或能量，进行维修时务必小心。

警告

當系統正在進行時，背板上有危險的電壓或能量，進行維修時務必小心。

Warnung

Wenn das System in Betrieb ist, treten auf der Rückwandplatine gefährliche Spannungen oder Energien auf. Vorsicht bei der Wartung.

¡Advertencia!

Cuando el sistema está en funcionamiento, el voltaje del plano trasero es peligroso. Tenga cuidado cuando lo revise.

Attention

Lorsque le système est en fonctionnement, des tensions électriques circulent sur le fond de panier. Prendre des précautions lors de la maintenance.

מתח בפנל האחורי

אזהרה!

קיימת סכנת מתח בפנל האחורי בזמן תפעול המערכת. יש להיזהר במהלך העבודה.

هناك خطر من التيار الكهربائي أو الطاقة المجددة على اللوحة عندما يكن النظام يعمل كه حذرا عند خدمة هذا الجهاز

경고!

시스템이 동작 중일 때 후면판 (Backplane)에는 위험한 전압이나 에너지가 발생 합니다. 서비스 작업 시 주의하십시오.

Waarschuwing

Een gevaarlijke spanning of energie is aanwezig op de backplane wanneer het systeem in gebruik is. Voorzichtigheid is geboden tijdens het onderhoud.

Comply with Local and National Electrical Codes



Warning! Installation of the equipment must comply with local and national electrical codes.

地方および国の電気規格に準拠

機器の取り付けはその地方および国の電気規格に準拠する必要があります。

警告

设备安装必须符合本地与本国电气法规。

警告

設備安裝必須符合本地與本國電氣法規。

Warnung

Die Installation der Geräte muss den Sicherheitsstandards entsprechen.

¡Advertencia!

La instalacion del equipo debe cumplir con las normas de electricidad locales y nacionales.

Attention

L'équipement doit être installé conformément aux normes électriques nationales et locales.

תיאום חוקי החשמל הארצי

אזהרה!

התקנת הציוד חייבת להיות תואמת לחוקי החשמל המקומיים והארציים.

تركيب المعدات الكهربائية يجب أن يمتثل للقوايه المحلية والبطية المتعلقة

بالكهرباء

경고!

현 지역 및 국가의 전기 규정에 따라 장비를 설치해야 합니다.

Waarschuwing

Bij installatie van de apparatuur moet worden voldaan aan de lokale en nationale elektriciteitsvoorschriften.

Product Disposal



Warning! Ultimate disposal of this product should be handled according to all national laws and regulations.

製品の廃棄

この製品を廃棄処分する場合、国の関係する全ての法律・条例に従い処理する必要があります。

警告

本产品的废弃处理应根据所有国家的法律和规章进行。

警告

本產品的廢棄處理應根據所有國家的法律和規章進行。

Warnung

Die Entsorgung dieses Produkts sollte gemäß allen Bestimmungen und Gesetzen des Landes erfolgen.

¡Advertencia!

Al deshacerse por completo de este producto debe seguir todas las leyes y reglamentos nacionales.

Attention

La mise au rebut ou le recyclage de ce produit sont généralement soumis à des lois et/ou directives de respect de l'environnement. Renseignez-vous auprès de l'organisme compétent.

סילוק המוצר

אזהרה!

סילוק סופי של מוצר זה חייב להיות בהתאם להנחיות וחוקי המדינה.

التخلص النهائي من هذا المنتج ينبغي التعامل معه وفقا لجميع القوانين واللوائح الوطنية عند

경고!

이 제품은 해당 국가의 관련 법규 및 규정에 따라 폐기되어야 합니다.

Waarschuwing

De uiteindelijke verwijdering van dit product dient te geschieden in overeenstemming met alle nationale wetten en reglementen.

Hot Swap Fan Warning



Warning! Hazardous moving parts. Keep away from moving fan blades. The fans might still be turning when you remove the fan assembly from the chassis. Keep fingers, screwdrivers, and other objects away from the openings in the fan assembly's housing.

ファン・ホットスワップの警告

警告!回転部品に注意。運転中は回転部(羽根)に触れないでください。シャーシから冷却ファン装置を取り外した際、ファンがまだ回転している可能性があります。ファンの開口部に、指、ドライバー、およびその他のものを近づけないで下さい。

警告!

警告! 危険的可移動性零件。请务必与转动的风扇叶片保持距离。当您从机架移除风扇装置，风扇可能仍在转动。小心不要将手指、螺丝起子和其他物品太靠近风扇。

警告

危険的可移動性零件。請務必與轉動的風扇葉片保持距離。當您從機架移除風扇裝置，風扇可能仍在轉動。小心不要將手指、螺絲起子和其他物品太靠近風扇。

Warnung

Gefährlich Bewegende Teile. Von den bewegenden Lüfterblätter fern halten. Die Lüfter drehen sich u. U. noch, wenn die Lüfterbaugruppe aus dem Chassis genommen wird. Halten Sie Finger, Schraubendreher und andere Gegenstände von den Öffnungen des Lüftergehäuses entfernt.

¡Advertencia!

Riesgo de piezas móviles. Mantener alejado de las aspas del ventilador. Los ventiladores podran dar vuelta cuando usted quite ell montaje del ventilador del chasis. Mandtenga los dedos, los destornilladores y todos los objetos lejos de las aberturas del ventilador

Attention

Pieces mobiles dangereuses. Se tenir a l'écart des lames du ventilateur Il est possible que les ventilateurs soient toujours en rotation lorsque vous retirerez le bloc ventilateur du châssis. Prenez garde à ce que doigts, tournevis et autres objets soient éloignés du logement du bloc ventilateur.

אזהרה!

חלקים נעים מסוכנים. התרחק מלהבי המאוורר בפעולה כאשר מסירים את חלקי המאוורר מהמארז, יתכן והמאווררים עדיין עובדים. יש להרחיק למרחק בטוח את האצבעות וכלי עבודה שונים מהפתחים בתוך המאוורר

تحذير! أجزاء متحركة خطيرة. ابتعد عن شفرات المروحة المتحركة. من الممكن أن المراوح لا تزال تدور عند إزالة كتلة المروحة من الهيكل يجب إبقاء الأصابع ومفكات البراغي وغيرها من الأشياء بعيدا عن الفتحات في كتلة المروحة.

경고!

움직이는 위험한 부품. 회전하는 송풍 날개에 접근하지 마세요. 새시로부터 팬 조립품을 제거할 때 팬은 여전히 회전하고 있을 수 있습니다. 팬 조립품 외관의 열려있는 부분들로부터 손가락 및 스크류드라이버, 다른 물체들이 가까이 하지 않도록 배치해 주십시오.

Waarschuwing

Gevaarlijk bewegende onderdelen. Houd voldoende afstand tot de bewegende ventilatorbladen. Het is mogelijk dat de ventilator nog draait tijdens het verwijderen van het ventilatorsamenstel uit het chassis. Houd uw vingers, schroevendraaiers en eventuele andere voorwerpen uit de buurt van de openingen in de ventilatorbehuizing.

Power Cable and AC Adapter



Warning! When installing the product, use the provided or designated connection cables, power cables and AC adaptors. Using any other cables and adaptors could cause a malfunction or a fire. Electrical Appliance and Material Safety Law prohibits the use of UL or CSA -certified cables (that have UL/CSA shown on the cord) for any other electrical devices than products designated by Supermicro only.

電源コードとACアダプター

製品を設置する場合、提供または指定および購入された接続ケーブル、電源コードとACアダプターを該当する地域の条例や安全基準に適合するコードサイズやプラグと共に使用下さい。他のケーブルやアダプタを使用すると故障や火災の原因になることがあります。

電気用品安全法は、ULまたはCSA認定のケーブル(UL/CSAマークがコードに表記)を Supermicro が指定する製品以外に使用することを禁止しています。

警告

安装此产品时,请使用本身提供的或指定的或采购的连接线,电源线和电源适配器。包含遵照当地法规和安全要求的合规的电源线尺寸和插头。使用其它线材或适配器可能会引起故障或火灾。除了Supermicro所指定的产品,电气用品和材料安全法律规定禁止使用未经UL或CSA认证的线材。(线材上会显示UL/CSA符号)。

警告

安裝此產品時,請使用本身提供的或指定的或採購的連接線,電源線和電源適配器。包含遵照當地法規和安全要求的合規的電源線尺寸和插頭。使用其它線材或適配器可能會引起故障或火災。除了Supermicro所指定的產品,電氣用品和材料安全法律規定禁止使用未經UL或CSA認證的線材。(線材上會顯示UL/CSA符號)。

Warnung

Nutzen Sie beim Installieren des Produkts ausschließlich die von uns zur Verfügung gestellten Verbindungskabeln, Stromkabeln und/oder Adapter, die Ihre örtlichen Sicherheitsstandards einhalten. Der Gebrauch von anderen Kabeln und Adapter können Fehlfunktionen oder Feuer verursachen. Die Richtlinien untersagen das Nutzen von UL oder CAS zertifizierten Kabeln (mit UL/CSA gekennzeichnet), an Geräten oder Produkten die nicht mit Supermicro gekennzeichnet sind.

¡Advertencia!

Cuando instale el producto, utilice la conexión provista o designada o procure cables, Cables de alimentación y adaptadores de CA que cumplan con los códigos locales y los requisitos de seguridad, incluyendo el tamaño adecuado del cable y el enchufe. El uso de otros cables y adaptadores podría causar un mal funcionamiento o un incendio. La Ley de Seguridad de Aparatos Eléctricos y de Materiales prohíbe El uso de cables certificados por UL o CSA (que tienen el certificado UL / CSA en el código) para cualquier otros dispositivos eléctricos que los productos designados únicamente por Supermicro.

Attention

Lors de l'installation du produit, utilisez les cables de connection fournis ou désigné ou achetez des cables, cables de puissance et adaptateurs respectant les normes locales et les conditions de securite y compris les tailles de cables et les prises electriques appropries. L'utilisation d'autres cables et adaptateurs peut provoquer un dysfonctionnement ou un incendie. Appareils électroménagers et la Loi sur la Sécurité Matériel interdit l'utilisation de câbles certifiés- UL ou CSA (qui ont UL ou CSA indiqué sur le code) pour tous les autres appareils électriques sauf les produits désignés par Supermicro seulement.

AC ימאתמו סיילמשח סילבכ

!הרהזא

ךרוצל ומאתוה וא ושכרנ רשא AC מימאתמו סיקפס, סילבכב שמתשהל שי, רצומה תא מיניקתמ רשאכ לכב שומיש. עקתהו לבכה לש הנוכח הדימ ללוכ, תוימוקמה תוחיטבה תושירדל ומאתוה רשאו, הנקתהה למשחה ירישכמב שומישה יקוחל סאתהב. ילמשח רצק וא הלוקתל סורגל לולע, רחא גוסמ סאתמ וא לבכ לש דוק סהילע עיפומ רשאכ) UL-ב או CSA-ב UL-ב מיכסומה סילבכב שמתשהל רוסיא סייק, תוחיטבה יקוחו דבלב Supermicro י"ע סאתוה רשא רצומב קר אלא, רחא ילמשח רצומ לכ רובע (UL/CSA)

تالبالكلا ءارشب مق وأ ءددحملأ وأ ءرفوتملأ تالبيصوتلأ مادختساب مق، جتئلأ بيكفرت دن ع لكلذ يف امب ءيلحملأ ءمالسلأ تابلطتمو نين او قب مازتلأ عم ددرتئلأ رايئلأ تالوحو ءيئابرهكلا قيروح وأ لطلع يف ببستتي دق ىرخأ تالوحو تالبالك ي مادختسا. ميلسلأ سبالل او لصولمأ م جح CSA وأ UL لبق نم ءدمتعملأ تالبالكلا مادختسا تادعملأ ءيئابرهكلا ءزهألل ءمالسلأ نوناق رظحي Supermicro لبق نم ءددحملأ ءينعملأ تاجتئلأ ريغ ىرخأ تادعم يأ عم (UL/CSA) ءمالع لمحت يتلأو

전원 케이블 및 AC 어댑터

경고! 제품을 설치할 때 현지 코드 및 적절한 굵기의 코드와 플러그를 포함한 안전 요구 사항을 준수하여 제공되거나 지정된 연결 혹은 구매 케이블, 전원 케이블 및 AC 어댑터를 사용하십시오.

다른 케이블이나 어댑터를 사용하면 오작동이나 화재가 발생할 수 있습니다. 전기 용품 안전법은 UL 또는 CSA 인증 케이블 (코드에 UL / CSA가 표시된 케이블)을 Supermicro 가 지정한 제품 이외의 전기 장치에 사용하는 것을 금지합니다.

Stroomkabel en AC-Adapter

Waarschuwing! Bij het aansluiten van het Product uitsluitend gebruik maken van de geleverde Kabels of een andere geschikte aan te schaffen Aansluitmethode, deze moet altijd voldoen aan de lokale voorschriften en veiligheidsnormen, inclusief de juiste kabeldikte en stekker. Het gebruik van niet geschikte Kabels en/of Adapters kan een storing of brand veroorzaken. Wetgeving voor Elektrische apparatuur en Materiaalveiligheid verbied het gebruik van UL of CSA -gecertificeerde Kabels (met UL/CSA in de code) voor elke andere toepassing dan de door Supermicro hiervoor beoogde Producten.

Appendix B

System Specifications

Processors

Dual 4th Gen Intel Xeon Scalable processors in Socket E (LGA4677) with four UPIs (16 GT/s max.) and a thermal design power (TDP) of up to 350 W; Supports SP XCC, SP MCC, and Max Series (HBM) SKUs.

Chipset

Intel PCH C741

BIOS

AMI 32 MB SPI Flash EEPROM

Memory

Up to 8 TB 3DS RDIMM/RDIMM DDR5 (288-pin) ECC memory with speeds up to 4800 MT/s (1PDC) or 4400 MT/s (2DPC) in 32 DIMM slots; DIMM size up to 256GB at P12 V

Graphic Processing Units

HGX H100 8-GPU SXM5 Multi-GPU Board PCIe 5.0 x16 CPU-to-GPU Interconnect, NVIDIA NVLink with NVSwitch

Storage Drives

Nineteen 2.5" hot-swap front drive bays: 16 NVMe and 3 SATA
Two M.2 NVMe SSDs

PCI Expansion Slots

Twelve PCIe 5.0 slots (two require an [optional NIC kit](#))

Input/Output

LAN: One dedicated BMC LAN port
USB: Two USB 3.0 ports
Video: One VGA port

Motherboard

X13DEG-OAD, 15.00" (W) X 17.00" (L) (381.00mm x 431.8mm)

Chassis

CSE-GP801TS; 8U Rackmount, 17.2" x 14" x 33.2" (WxHxD) (43.7 x 356 x 843 cm)

System Cooling

Eighteen heavy duty fans with speed control, including fans as part of the power modules
Motherboard air shrouds

Power Supply

(Six default) PWS-3K06G-2R, 3000 W 3 + 3 redundant modules, 80Plus Titanium level

Input:

2880W: 200-207 Vac, 16-15.7 A, 50-60 Hz
3000W: 207.1-240 Vac, 16-14.5 A, 50-60 Hz
3000W: 240 Vdc, 15 A

DC Output:

+54V, 45 A
+12V, 91.66 A
+12Vsb, 3 A

Operating Environment

Operating Temperature: 10° to 35° C (50° to 95° F)
Non-operating Temperature: -40° to 60° C (-40° to 140° F)
Operating Relative Humidity: 8% to 90% (non-condensing)
Non-operating Relative Humidity: 5% to 95% (non-condensing)

Regulatory Compliance

FCC, ICES, CE, VCCI, RCM, UKCA, NRTL, CB

Applied Directives, Standards

EMC/EMI: 2014/30/EU (EMC Directive)

Electromagnetic Compatibility Regulations 2016

FCC Part 15

ICES-003

VCCI-CISPR 32

AS/NZS CISPR 32

BS/EN55032

BS/EN55035

CISPR 32

CISPR 35

BS/EN 61000-3-2

BS/EN 61000-3-3

BS/EN 61000-4-2

BS/EN 61000-4-3

BS/EN 61000-4-4

BS/EN 61000-4-5

BS/EN 61000-4-6

BS/EN 61000-4-8

BS/EN 61000-4-11

Environment:

2011/65/EU (RoHS Directive)

EC 1907/2006 (REACH)

2012/19/EU (WEEE Directive)

California Proposition 65

Product Safety: 2014/35/EU (LVD Directive)

UL/CSA 62368-1 (USA and Canada)

Electrical Equipment (Safety) Regulations 2016

IEC/BS/EN 62368-1

Perchlorate Warning

California Best Management Practices Regulations for Perchlorate Materials: This Perchlorate warning applies only to products containing CR (Manganese Dioxide) Lithium coin cells. "Perchlorate Material-special handling may apply. See www.dtsc.ca.gov/hazardouswaste/perchlorate"

この装置は、クラスA機器です。この装置を住宅環境で使用すると電波妨害を引き起こすことがあります。この場合には使用者が適切な対策を講ずるよう要求されることがあります。

VCCI — A

General Data Center Environmental Specifications

Particulate contamination specifications

Air filtration: Data centers must be kept clean to Class 8 of ISO 14644-1 (ISO 2015). The air entering the data center should be filtered with a MERV 11 filter or better. The air within the data center should be continuously filtered with a MERV 8 filter or better.

Conductive dust: Air should be free of conductive dust, zinc whiskers, or other conductive particles.

Corrosive dust: Air should be free of corrosive dust.

Gaseous* contamination specifications

Copper coupon corrosion rate: <300 Å/month per class G1 as defined by ANSI.ISA71.04-2013, referenced by ASHRAE TC 9.9

Silver coupon corrosion rate: <200 Å/month per class G1 as defined by ANSI.ISA71.04-2013, referenced by ASHRAE TC 9.9

*If testing with silver or copper coupons results in values less than 200 Å/month or 300 Å/month, respectively, then operating up to 70% relative humidity (RH) is acceptable. If the testing shows corrosion levels exceed these limits, then catalyst-type pollutants are probably present and RH should be driven to 50% or lower.