



# SUPERSERVER<sup>®</sup> SYS-821GE-TNMR2



USER'S MANUAL

Revision 1.0

The information in this User's Manual has been carefully reviewed and is believed to be accurate. The vendor assumes no responsibility for any inaccuracies that may be contained in this document, and makes no commitment to update or to keep current the information in this manual, or to notify any person or organization of the updates. Please Note: For the most up-to-date version of this manual, please see our website at [www.supermicro.com](http://www.supermicro.com).

Super Micro Computer, Inc. ("Supermicro") reserves the right to make changes to the product described in this manual at any time and without notice. This product, including software and documentation, is the property of Supermicro and/or its licensors, and is supplied only under a license. Any use or reproduction of this product is not allowed, except as expressly permitted by the terms of said license.

IN NO EVENT WILL Super Micro Computer, Inc. BE LIABLE FOR DIRECT, INDIRECT, SPECIAL, INCIDENTAL, SPECULATIVE OR CONSEQUENTIAL DAMAGES ARISING FROM THE USE OR INABILITY TO USE THIS PRODUCT OR DOCUMENTATION, EVEN IF ADVISED OF THE POSSIBILITY OF SUCH DAMAGES. IN PARTICULAR, SUPER MICRO COMPUTER, INC. SHALL NOT HAVE LIABILITY FOR ANY HARDWARE, SOFTWARE, OR DATA STORED OR USED WITH THE PRODUCT, INCLUDING THE COSTS OF REPAIRING, REPLACING, INTEGRATING, INSTALLING OR RECOVERING SUCH HARDWARE, SOFTWARE, OR DATA.

Any disputes arising between manufacturer and customer shall be governed by the laws of Santa Clara County in the State of California, USA. The State of California, County of Santa Clara shall be the exclusive venue for the resolution of any such disputes. Supermicro's total liability for all claims will not exceed the price paid for the hardware product.

FCC Statement: This equipment has been tested and found to comply with the limits for a Class A or Class B digital device pursuant to Part 15 of the FCC Rules. These limits are designed to provide reasonable protection against harmful interference when the equipment is operated in industrial environment for Class A device or in residential environment for Class B device. This equipment generates, uses, and can radiate radio frequency energy and, if not installed and used in accordance with the manufacturer's instruction manual, may cause harmful interference with radio communications. Operation of this equipment in a residential area is likely to cause harmful interference, in which case you will be required to correct the interference at your own expense.

California Best Management Practices Regulations for Perchlorate Materials: This Perchlorate warning applies only to products containing CR (Manganese Dioxide) Lithium coin cells. Perchlorate Material-special handling may apply. See [www.dtsc.ca.gov/hazardouswaste/perchlorate](http://www.dtsc.ca.gov/hazardouswaste/perchlorate).



WARNING: This product can expose you to chemicals including lead, known to the State of California to cause cancer and birth defects or other reproductive harm. For more information, go to [www.P65Warnings.ca.gov](http://www.P65Warnings.ca.gov).

The products sold by Supermicro are not intended for and will not be used in life support systems, medical equipment, nuclear facilities or systems, aircraft, aircraft devices, aircraft/emergency communication devices or other critical systems whose failure to perform be reasonably expected to result in significant injury or loss of life or catastrophic property damage. Accordingly, Supermicro disclaims any and all liability, and should buyer use or sell such products for use in such ultra-hazardous applications, it does so entirely at its own risk. Furthermore, buyer agrees to fully indemnify, defend and hold Supermicro harmless for and against any and all claims, demands, actions, litigation, and proceedings of any kind arising out of or related to such ultra-hazardous use or sale.

Manual Revision 1.0

Release Date: September 06, 2024

Unless you request and receive written permission from Super Micro Computer, Inc., you may not copy any part of this document. Information in this document is subject to change without notice. Other products and companies referred to herein are trademarks or registered trademarks of their respective companies or mark holders.

Copyright © 2024 by Super Micro Computer, Inc.  
All rights reserved.

**Printed in the United States of America**

# Preface

## About this Manual

This manual is written for professional system integrators and PC technicians. It provides information for the installation and use of this server. Installation and maintenance should be performed by certified service technicians only.

Please refer to the SYS-821GE-TNMR2 server specifications [page](#) on our website for updates on supported memory, processors and operating systems ([www.supermicro.com](http://www.supermicro.com)).

## Notes

For your system to work properly, please follow the links below to download all necessary drivers/utilities and the user's manual for your server.

- Supermicro product manuals: <https://www.supermicro.com/support/manuals/>
- Product drivers and utilities: <https://www.supermicro.com/wdl/>
- Product safety info: <https://www.supermicro.com/en/about/policies/safety-information>

If you have any questions, please contact our support team at: [support@supermicro.com](mailto:support@supermicro.com)

This manual may be periodically updated without notice. Please check the Supermicro website for possible updates to the manual revision level.

## Secure Data Deletion

A secure data deletion tool designed to fully erase all data from storage devices can be found on our website: [https://www.supermicro.com/about/policies/disclaimer.cfm?url=/wdl/utility/Lot9\\_Secure\\_Data\\_Deletion\\_Utility/](https://www.supermicro.com/about/policies/disclaimer.cfm?url=/wdl/utility/Lot9_Secure_Data_Deletion_Utility/)

## Warnings

Special attention should be given to the following symbols used in this manual.



**Warning!** Indicates important information given to prevent equipment/property damage or personal injury.



**Warning!** Indicates high voltage may be encountered when performing a procedure.

# Contents

## **Chapter 1 Introduction**

1.1 Overview.....	9
1.2 System Features .....	10
Front View .....	10
Drive Carrier Indicators.....	11
Control Panel.....	12
Rear View.....	14
Power Supply Indicator.....	15
Fan Module Indicator.....	15
Top View, Motherboard Tray .....	16
Top View, GPU Tray.....	17
1.3 System Block Diagram.....	18
1.4 Motherboard Layout .....	19
Quick Reference Table.....	20
Motherboard Block Diagram .....	22

## **Chapter 2 Server Installation**

2.1 Overview.....	23
2.2 Unpacking the System .....	23
2.3 Preparing for Setup.....	23
Choosing a Setup Location.....	23
Rack Precautions .....	24
Server Precautions.....	24
Rack Mounting Considerations .....	24
Ambient Operating Temperature.....	24
Airflow .....	24
Mechanical Loading.....	25
Circuit Overloading .....	25
Reliable Ground.....	25
2.4 Installing the Rails .....	26
2.5 Installing the Server .....	28

## **Chapter 3 Maintenance and Component Installation**

3.1 Removing Power .....	29
3.2 Accessing the System.....	29
3.3 Processor and Heatsink .....	34

Processor Overview .....	34
Installation Overview .....	35
Installation Procedure Overview .....	35
Create the Processor Carrier Assembly .....	36
Assemble the Processor Heatsink Module .....	40
Remove the Socket Cover .....	42
Install the PHM .....	43
Removing the PHM .....	46
Removing the Carrier Assembly from the Heatsink .....	48
Removing the Processor from the Carrier Assembly .....	49
3.4 Memory Support and Installation .....	50
Memory Support .....	50
DDR5 Memory Support for 5 <sup>th</sup> /4 <sup>th</sup> Gen. Intel Xeon Scalable Processors .....	50
Memory Population for the X13DEG-M Motherboard (with 32 DIMM Slots) .....	52
Memory Slots .....	54
DIMM Installation .....	56
DIMM Removal .....	57
Motherboard Battery .....	58
3.5 Storage Drives .....	59
Installing Hot-Swap Drives .....	59
M.2 Drives .....	61
Checking the Temperature of an NVMe Drive .....	62
3.6 System Cooling .....	63
Changing a System Fan .....	63
Motherboard Air Shroud .....	64
GPU Air Blockers .....	65
3.7 PCIe Expansion Cards .....	66
Installing Expansion Cards (1–8) .....	67
Installing Riser Expansion Cards (9–12) .....	68
3.8 Power Supply .....	70
Power Supply LEDs .....	70
<b>Chapter 4 Motherboard Connections</b>	
4.1 Power Connections .....	72
4.2 Headers and Connectors .....	74
4.3 Input/Output Ports .....	79

---

---

I/O Module Connectors .....	79
4.4 Jumpers .....	80
How Jumpers Work.....	80
4.5 LED Indicators .....	81
4.6 M.2 Solid State Drive Installation .....	82
<b>Chapter 5 Software</b>	
5.1 Microsoft Windows OS Installation.....	83
5.2 Driver Installation.....	85
5.3 BMC.....	86
5.4 Logging into the BMC .....	86
<b>Chapter 6 Optional Components</b>	
6.1 Power Supply Modules .....	87
6.2 NIC Kit.....	87
6.3 Additional Storage Drives.....	88
<b>Chapter 7 Troubleshooting and Support</b>	
7.1 Information Resources .....	89
Website .....	89
Direct Links for the SYS-821GE-TNMR2 System .....	89
Direct Links for General Support and Information .....	89
7.2 BMC Interface .....	90
7.3 Troubleshooting Procedures .....	91
Before Power On .....	91
No Power .....	91
No Video .....	92
System Boot Failure .....	92
Memory Errors .....	92
Losing the System Setup Configuration .....	92
When the System Becomes Unstable .....	93
Issues with NVMe Storage Devices.....	94
7.4 BIOS POST Codes.....	95
7.5 Technical Support Procedures .....	95
7.6 Frequently Asked Questions .....	96
7.7 Battery Removal and Installation .....	97
Battery Removal.....	97
Proper Battery Disposal .....	97

---

---



---

Battery Installation.....	97
7.8 Where to Get Replacement Components .....	98
7.9 Reporting an Issue .....	98
Returning Merchandise for Service.....	98
7.10 Feedback.....	98
7.11 Contacting Supermicro .....	99

***Appendix A Standardized Warning Statements for AC Systems***

***Appendix B System Specifications***

---

---

## Contacting Supermicro

### Headquarters

Address: Super Micro Computer, Inc.  
980 Rock Ave.  
San Jose, CA 95131 U.S.A.

Tel: +1 (408) 503-8000

Fax: +1 (408) 503-8008

Email: [marketing@supermicro.com](mailto:marketing@supermicro.com) (General Information)  
[Sales-USA@supermicro.com](mailto:Sales-USA@supermicro.com) (Sales Inquiries)  
[Government\\_Sales-USA@supermicro.com](mailto:Government_Sales-USA@supermicro.com) (Gov. Sales Inquiries)  
[support@supermicro.com](mailto:support@supermicro.com) (Technical Support)  
[RMA@supermicro.com](mailto:RMA@supermicro.com) (RMA Support)  
[Webmaster@supermicro.com](mailto:Webmaster@supermicro.com) (Webmaster)

Website: [www.supermicro.com](http://www.supermicro.com)

### Europe

Address: Super Micro Computer B.V.  
Het Sterrenbeeld 28, 5215 ML  
's-Hertogenbosch, The Netherlands

Tel: +31 (0) 73-6400390

Fax: +31 (0) 73-6416525

Email: [Sales\\_Europe@supermicro.com](mailto:Sales_Europe@supermicro.com) (Sales Inquiries)  
[Support\\_Europe@supermicro.com](mailto:Support_Europe@supermicro.com) (Technical Support)  
[RMA\\_Europe@supermicro.com](mailto:RMA_Europe@supermicro.com) (RMA Support)

Website: [www.supermicro.nl](http://www.supermicro.nl)

### Asia-Pacific

Address: Super Micro Computer, Inc.  
3F, No. 150, Jian 1st Rd.  
Zhonghe Dist., New Taipei City 235  
Taiwan (R.O.C)

Tel: +886-(2) 8226-3990

Fax: +886-(2) 8226-3992

Email: [Sales-Asia@supermicro.com.tw](mailto:Sales-Asia@supermicro.com.tw) (Sales Inquiries)  
[Support@supermicro.com.tw](mailto:Support@supermicro.com.tw) (Technical Support)  
[RMA@supermicro.com.tw](mailto:RMA@supermicro.com.tw) (RMA Support)

Website: [www.supermicro.com.tw](http://www.supermicro.com.tw)

# Chapter 1

## Introduction

### 1.1 Overview

This chapter provides an outline of the functions and features of the SuperServer SYS-821GE-TNMR2. The system is based on the X13DEG-MA motherboard and the CSE-GP801TS chassis. This is an HPC GPU system that supports AMD Instinct™ MI300X GPU Accelerators. The following provides an overview of the specifications and capabilities of the system.

System Overview	
<b>Motherboard</b>	X13DEG-MA
<b>Chassis</b>	CSE-GP801TS
<b>Processors</b>	Supports dual 4th and 5th Gen Intel Xeon Scalable processors in Socket E (LGA 4677), thermal design power (TDP) of up to 350W. - 4th Gen: up to 60 cores and supports SP XCC, SP MCC, and Max Series (HBM) SKUs. - 5th Gen: up to 64 cores and supports SP XCC and SP MCC SKUs.
<b>Memory</b>	Supports up to 8 TB 3DS RDIMM/RDIMM DDR5 (288-pin) ECC memory with speeds up to 5600 MT/s (1PDC) or 4400 MT/s (2DPC) in 32 DIMM slots <b>Note:</b> Memory speed and capacity support depends on the processors used in the system.
<b>GPUs</b>	Eight AMD Instinct™ MI300X GPU Accelerators
<b>Storage</b>	Twelve PCIe 5.0 x4 NVMe U.2 Four PCIe 5.0 x4 NVMe U.2 (optional) Two onboard NVMe M.2 slots Eight 2.5" SATA
<b>Expansion Slots</b>	Eight PCIe 5.0 x16 LP slots Two PCIe 5.0 x16 FHFL slots (slots 11 and 12) (Optional) Two PCIe 5.0 x16 FHFL slots (slots 9 and 10)
<b>I/O Ports</b>	One VGA port Two USB 3.0 ports One Dedicated IPMI RJ45 port
<b>System Cooling</b>	Five front and five rear 8-cm fans with optimal fan speed control
<b>Power</b>	Six redundant power supplies (4+2 redundancy) with the option for two more (4+4 redundancy); 3000W (per power supply), 80Plus Titanium level
<b>Form Factor</b>	8U; 17.2" x 14" x 33.2" (W x H x D), (43.7 x 356 x 843 cm)

A Quick Reference Guide can be found on the [product page](#) of the Supermicro website.

The following safety models associated with the SYS-821GE-TNMR2 have been certified as compliant with UL and CSA: GP801-H30X13, GP801-GPU, GP801-3.

## 1.2 System Features

The following views of the system display the main features.

### Front View

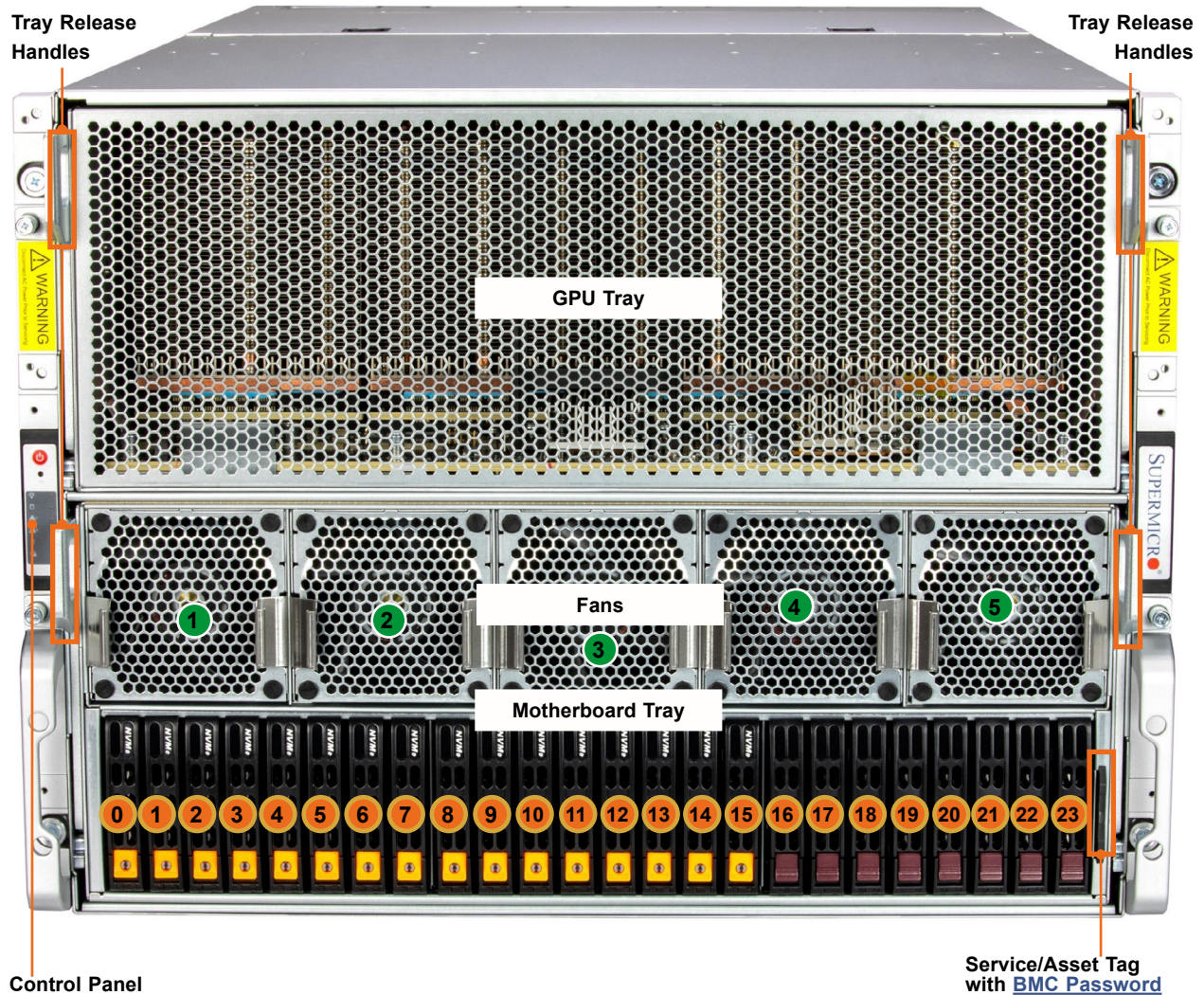

Figure 1-1. Front View

Logical Storage Drive Numbers	
Item	Description
0 to 11	Twelve 2.5-inch hot-swap NVMe drive bays
12 to 15	(Optional) Four 2.5-inch hot-swap NVMe drive bays (optional)
16 to 23	Eight 2.5-inch hot-swap SATA drive bays

### ***Drive Carrier Indicators***

Each drive carrier has two LED indicators: an activity indicator and a status indicator. For RAID configurations using a controller, the meaning of the status indicator is described in the table below. For OS RAID or non-RAID configurations, some LED indications are not supported, such as hot spare.

<b>System Features: Front</b>			
	<b>Color</b>	<b>Blinking Pattern</b>	<b>Behavior for Device</b>
Activity LED	Blue	Blinking	I/O activity
	Off		Idle SATA drive installed
Status LED	Green	Solid On	Safe to remove NVMe drive
	Amber	Blinking at 1 Hz	Do not remove NVMe drive

**Figure 1-2. Input/Output Panel**

## Control Panel

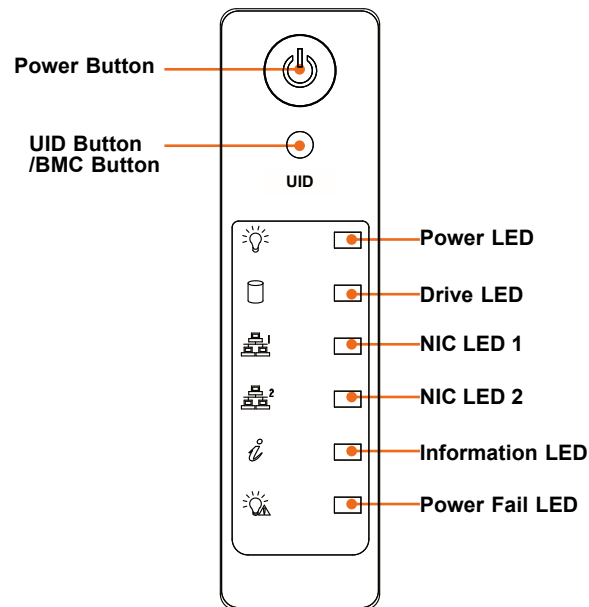

**Figure 1-3. Control Panel**

Control Panel Features	
Features	Description
Power Button	The main power switch applies or removes primary power from the power supply to the server but maintains standby power.
UID button/ BMC button	The unit identification (UID) button turns on or off the blue light function of the Information LED. This button can also be used to <a href="#">reset the BMC</a> .
Power LED	Steady on – Power on Blinking at 4Hz – Checking BIOS/BMC integrity Blinking at 4Hz and "i" LED is blue – BIOS firmware updating Two blinks at 4Hz, one pause 2hz and "i" LED blue – BMC firmware updating Blinking at 1Hz and "i" LED red – Fault detected
Drive LED	Indicates activity on the storage drives when flashing.
NIC LEDs	Non-functional, as there are no onboard network connections.
Information LED	Alerts operator to several states (noted in the table below).
Power Fail LED	Indicates a power supply module has failed.

Information LED	
Color, Status	Description
Red, solid	An overheating condition has occurred
Red, blinking at 1 Hz	Fan failure, check for an inoperative fan
Red, blinking at 0.25 Hz	Power failure, check for a non-operational power supply
Red, blinking at 10 Hz	CPLD recovery mode error

*(Table continued on next page)*

Information LED	
Color, Status	Description
Blue, solid	Unit ID has been activated by button
Blue, blinking at 1 Hz	Unit ID has been activated using the BMC
Blue, blinking at 2 Hz, and BMC Heartbeat LED on the motherboard is green	BMC is resetting
Blue, blinking at 4 Hz	BMC is setting factory defaults
Blue, blinking at 10 Hz	BIOS/BMC is recovering or updating

Front Control Panel LED Indicators						
Event	Power	HDD	NIC	UID	Info	Power Fail
Power On	Solid On					
HDD Activity		Blinking				
NIC Activity			Blinking			
Overheat					Solid On	
Fan Fail					Blinking 1 Hz	
Power Fail					Blinking 1/4 Hz	Solid On
Local UID On				Solid On		
Remote UID On				Blinking at 1 Hz		
Checking BMC/BIOS	Blinking at 4 Hz					
Recovering/Updating	BMC Blinking at 4 Hz BMC 2 Blinks at 4 Hz, 1 Pause at 2 Hz (on-on-off-off)			BIOS/BMC Blinking at 10 Hz		
Flash Not Detected or Golden Image Check Failed	BMC/BIOS Blinking at 1 Hz					
CPLD Recovery Mode				Blinking at 10 Hz (MB UID LED)	Blinking at 10 Hz (FP Red LED)	

## Rear View

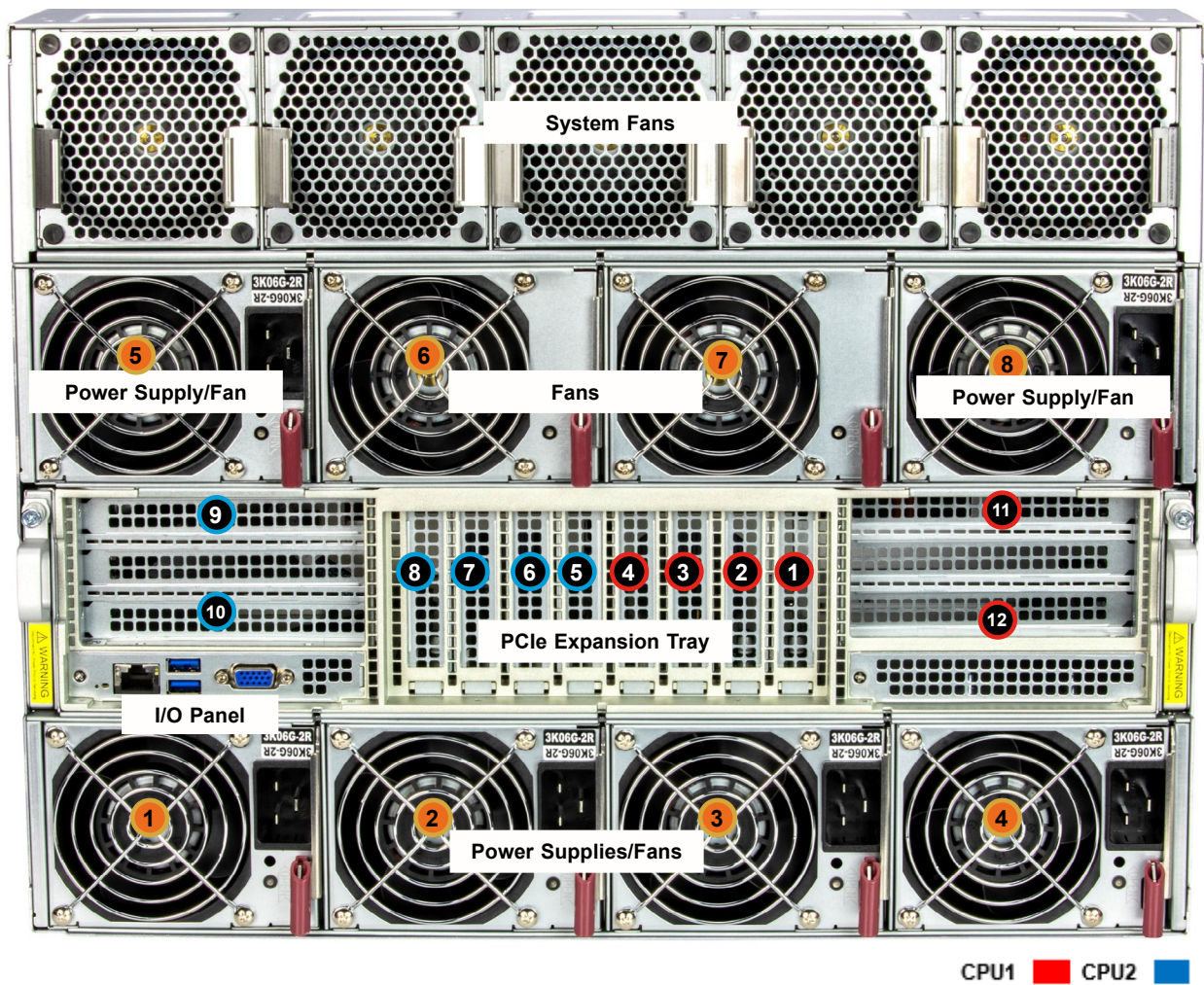

Figure 1-4. System: Rear View

System Features: Rear	
Feature	Description
System Fans	Five exhaust fans
Power Supply/Fans	Six combination 3000 W power supply modules with system cooling fans, logical numbering shown
PCle Slots	Twelve slots for PCIe expansion cards, logical numbering shown
I/O Panel	See next page for details on the input/output panel

Expansion Slot Locations	
Slot	Description
1	PCIe 5.0 x16 (LP) from PLX switch to GPUs
2	PCIe 5.0 x16 (LP) from PLX switch to GPUs
3	PCIe 5.0 x16 (LP) from PLX switch to GPUs
4	PCIe 5.0 x16 (LP) from PLX switch to GPUs
5	PCIe 5.0 x16 (LP) from PLX switch to GPUs
6	PCIe 5.0 x16 (LP) from PLX switch to GPUs
7	PCIe 5.0 x16 (LP) from PLX switch to GPUs
8	PCIe 5.0 x16 (LP) from PLX switch to GPUs
9	PCIe 5.0 x16 (FHHL) (requires an <a href="#">optional NIC kit</a> )
10	PCIe 5.0 x16 (FHHL) (requires an <a href="#">optional NIC kit</a> )
11	PCIe 5.0 x16 (FHHL)
12	PCIe 5.0 x16 (FHHL)

### Power Supply Indicator

Power Supply Indicator	
LED Color and State	Power Supply Condition
Solid Green	Indicates that the power supply is on
Blinking Green	Indicates that the power supply is plugged in and turned off by the system.
Blinking Amber	Indicates that the power supply has a warning condition and continues to operate.
Solid Amber	Indicates that the power supply is plugged in, and is in an abnormal state. The system might need service. Please contact Supermicro technical support.
Off	No AC power to modules

### Fan Module Indicator

Fan Module Indicator	
LED Color and State	Condition
Solid Green	Indicates that the fan is on and working
Solid Amber	Indicates failure or needs attention
Solid Red	Indicates that the fan is receiving standby power
Off	Indicates the fan is off

## Top View, Motherboard Tray

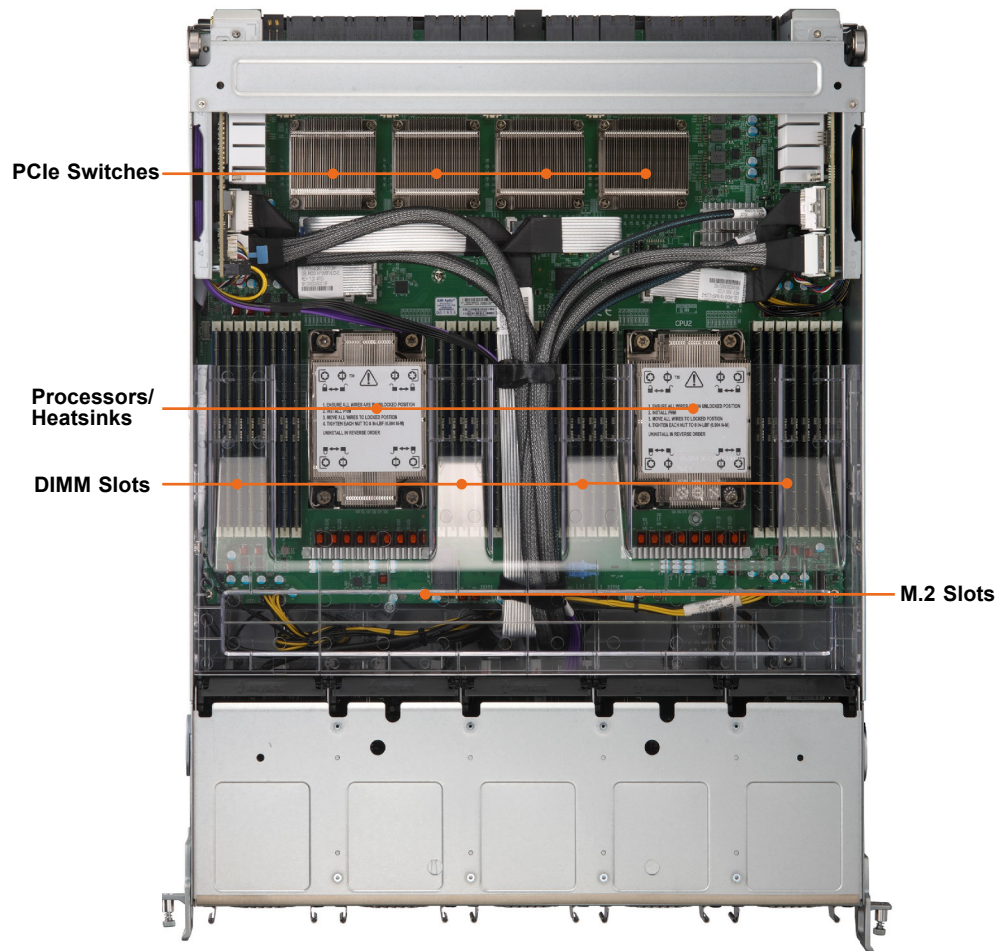

**Figure 1-5. Motherboard Tray: Top View**

Motherboard Tray Features	
Feature	Description
PCIe Switches	Four switches to facilitate direct communication between GPUs
Processors	Two 4th and 5th Gen Intel Xeon Scalable processors with heatsinks
DIMM Slots	Thirty-two memory slots
M.2 Slots	Two slots for PCIe 3.0 x2 M.2 NVMe

# Top View, GPU Tray

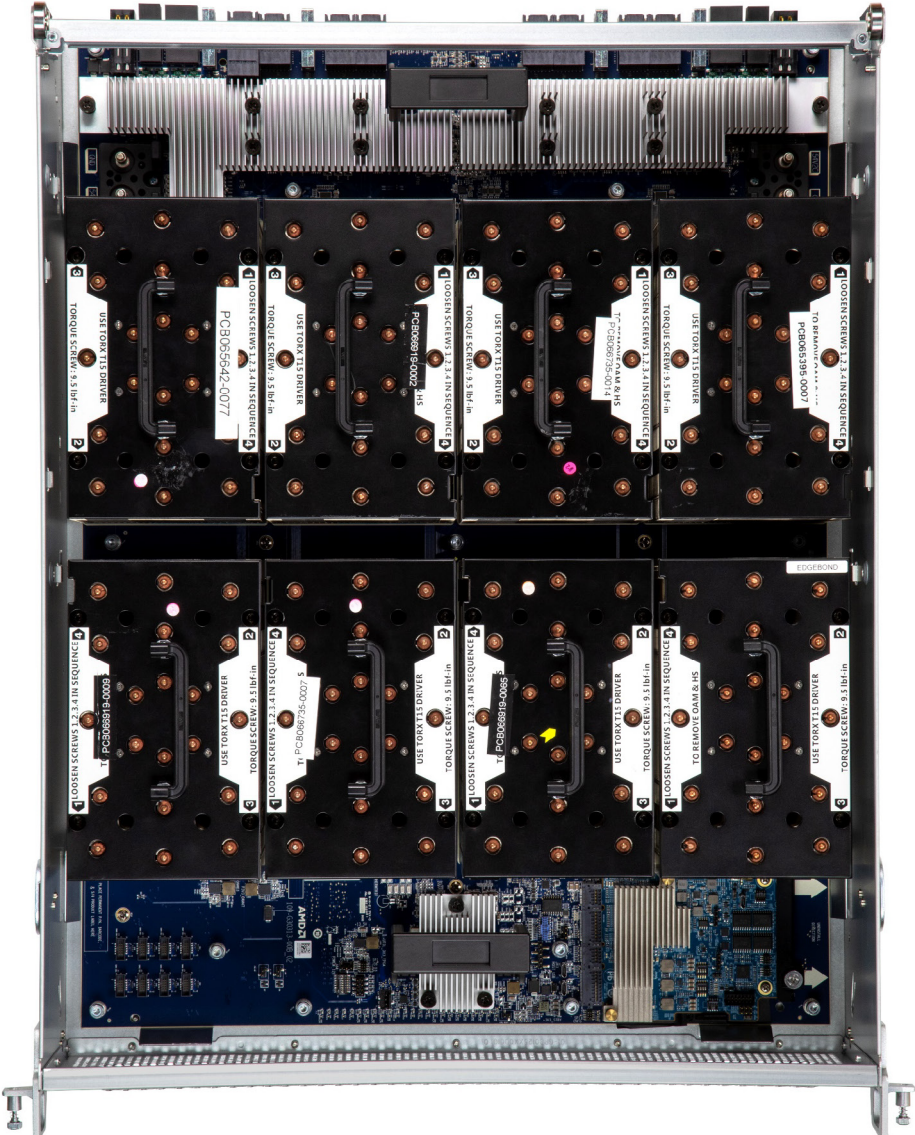

Figure 1-7. AMD Instinct MI300X 8-GPU Baseboard: Top View





## Quick Reference Table

Jumper	Description	Default Setting
JBT1	CMOS Clear	Open (Normal)
JDBG1, JDBG2	For manufacturing use only	Open (Normal)
JSWID1, JSWID2	PSUs and redundant PSUs support (For manufacturing use only)	JSWID1 and JSWID2: Pins 1-2 (Closed) Two PSUs and two redundant PSUs
JVRM1, JVRM2	For manufacturing use only	Pins 1-2 (Closed)

**Note:** JSWID1 and JSWID2 settings depend on the system configuration.

LED	Description	Status
LED4, LED7	M.2 Activity LED for JM2_D bottom/top M.2	Blinking Green: Device Working
LEDBMC	BMC Heartbeat LED	Blinking Green: BMC Normal (Active), Solid Green: During BMC Reset or during a Cold Reboot
LEDPWR	Power LED	LED On: Onboard Power On

Connector	Description
BT1	Onboard Battery
EJ21	I <sup>2</sup> C Header for Fan Board
EJNIC1 - 6	ExaMAX PCIe 5.0 Connectors for NIC card carrier board supporting eight PCIe 5.0 x 16 connections
EJNVME1 - 4	MCIO x8 Connectors supported by PLX switch, each supporting two PCIe 5.0 x4 NVMe connections
EJSW_3 - 10	ExaMAX Connectors for midplane to GPU system connection
EJSW_GDE1, EJSW_GDE2	Midplane Guide Pins
EJSW_P54V	54 V Power Input Connector from midplane
EJSW_PWR1, EJSW_PWR3, EJSW_PWR4	12 V PowerMAX Connector from midplane
EJSW_PWR2	12 V PowerMAX Connector for NIC card carrier board
FAN1 - 4	6-pin Cooling Fan Headers
FST_80, FST_110	Mounting holes for M.2 SSDs
JFP2	Connector for front I/O module (with support of USB, VGA and BMC dedicated LAN) (mutually exclusive with JSW1)
JIPMB1	4-pin BMC External I <sup>2</sup> C Header (for Inlet Temperature Sensor)
JLC1, JLC2	Liquid Cooling Leak Detection Connectors
JM2_D	M.2 Socket with two PCIe 3.0 x2 NVMe M.2 Slots supported by Intel PCH (with support of M-Key 2280 and 22110 form factors)
JMCIO1A, JMCIO1B	Two MCIO x8 Connectors supported by CPU1 for side switch board
JMCIO2A, JMCIO2B	Two MCIO x8 Connectors supported by CPU2 for side switch board
JNCSI1	NC-SI (Network Controller Sideband Interface) Connector
JNVI2C1	NVMe I <sup>2</sup> C Header for storage backplane
JNVVPP1	VPP I <sup>2</sup> C Header for storage backplane

---

---

<b>Connector</b>	<b>Description</b>
JPWR1 - 5	12 V Power Connectors
JRK1	Intel VROC Key Header for NVMe RAID support
JS1 (I-SATA 0 - 3), JS2 (I-SATA 4 - 7)	SlimSAS x4 Connectors supported by Intel PCH for eight SATA 3.0 connections (RAID 0, 1, 5, and 10 supported)
JSSW1, JSSW2	I <sup>2</sup> C Headers for side switch boards
JSW1	ExaMAX Connector for midplane to rear I/O module connection (with support of USB, VGA and BMC dedicated LAN) (mutually exclusive with JFP2)
JTPM1	Trusted Platform Module/Port 80 Connector
P54V_JPWR1	54 V Power Output Connector

## Motherboard Block Diagram

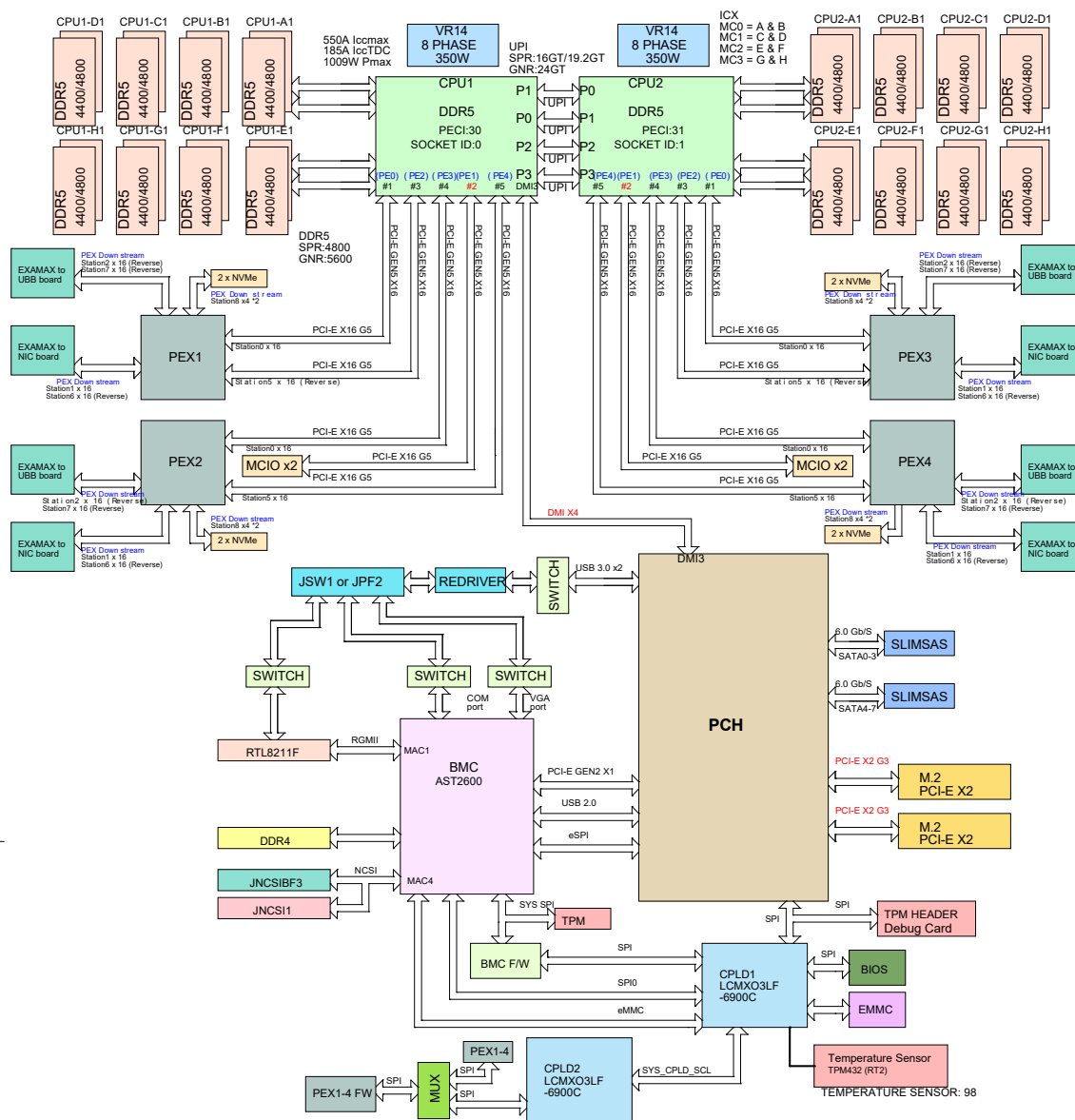

Figure 1-10. Motherboard Block Diagram

# Chapter 2

## Server Installation

### 2.1 Overview

This chapter provides advice and instructions for mounting your system in a server rack. If your system is not already fully integrated with processors, system memory, etc., refer to [Chapter 3](#) for details on installing those specific components.

**Caution:** Electrostatic Discharge (ESD) can damage electronic components. To prevent such damage to PCBs (printed circuit boards), it is important to use a grounded wrist strap, handle all PCBs by their edges and keep them in anti-static bags when not in use.

### 2.2 Unpacking the System

Inspect the box in which the SuperServer was shipped, and note if it was damaged in any way. If any equipment appears damaged, file a damage claim with the carrier who delivered it.

Decide on a suitable location for the rack unit that will hold the server. It should be situated in a clean, dust-free area that is well ventilated. Avoid areas where heat, electrical noise and electromagnetic fields are generated. It will also require a grounded AC power outlet nearby. Be sure to read the precautions and considerations noted in [Appendix A](#).

### 2.3 Preparing for Setup

The box in which the system was shipped should include the rackmount hardware needed to install it into the rack. Please read this section in its entirety before you begin the installation.

#### Choosing a Setup Location

- The system should be situated in a clean, dust-free area that is well ventilated. Avoid areas where heat, electrical noise and electromagnetic fields are generated.
- Leave enough clearance in front of the rack so that you can open the front door completely (~25 inches) and approximately 30 inches of clearance in the back of the rack to allow sufficient space for airflow and access when servicing.
- This product should be installed only in a Restricted Access Location (dedicated equipment rooms, service closets, etc.).
- This product is not suitable for use with visual display workplace devices according to §2 of the German Ordinance for Work with Visual Display Units.

## Rack Precautions

- Ensure that the leveling jacks on the bottom of the rack are extended to the floor so that the full weight of the rack rests on them.
- In single rack installations, stabilizers should be attached to the rack. In multiple rack installations, the racks should be coupled together.
- Always make sure the rack is stable before extending a server or other component from the rack.
- You should extend only one server or component at a time. Extending two or more simultaneously may cause the rack to become unstable.

## Server Precautions

- Review the electrical and general safety precautions in [Appendix A](#).
- Determine the placement of each component in the rack *before* you install the rails.
- Install the heaviest server components at the bottom of the rack first and then work your way up.
- Use a regulating uninterruptible power supply (UPS) to protect the server from power surges and voltage spikes and to keep your system operating in case of a power failure.
- Allow any drives and power supply modules to cool before touching them.
- When not servicing, always keep the front door of the rack and all covers/panels on the servers closed to maintain proper cooling.

## Rack Mounting Considerations

### *Ambient Operating Temperature*

If installed in a closed or multi-unit rack assembly, the ambient operating temperature of the rack environment may be greater than the room's ambient temperature. Therefore, consideration should be given to installing the equipment in an environment compatible with the manufacturer's maximum rated ambient temperature (TMRA).

### *Airflow*

Equipment should be mounted into a rack so that the amount of airflow required for safe operation is not compromised.

### ***Mechanical Loading***

Equipment should be mounted into a rack so that a hazardous condition does not arise due to uneven mechanical loading.

### ***Circuit Overloading***

Consideration should be given to the connection of the equipment to the power supply circuitry and the effect that any possible overloading of circuits might have on overcurrent protection and power supply wiring. Appropriate consideration of equipment nameplate ratings should be used when addressing this concern.

### ***Reliable Ground***

A reliable ground must be maintained at all times. To ensure this, the rack itself should be grounded. Particular attention should be given to power supply connections other than the direct connections to the branch circuit (i.e. the use of power strips, etc.).



**Warning!** To prevent bodily injury when mounting or servicing this unit in a rack, you must take special precautions to ensure that the system remains stable. The following guidelines are provided to ensure your safety:

- This unit should be mounted at the bottom of the rack if it is the only unit in the rack.
- When mounting this unit in a partially filled rack, load the rack from the bottom to the top with the heaviest component at the bottom of the rack.
- If the rack is provided with stabilizing devices, install the stabilizers before mounting or servicing the unit in the rack.
- Slide rail mounted equipment is not to be used as a shelf or a work space.

## 2.4 Installing the Rails

There are a variety of rack units on the market, which may require a slightly different assembly procedure. Also refer to the installation instructions that came with the rack.

This rail set fits a rack between 28" and 33.5" deep. Do not use a two post "telco" type rack.

1. Identify the left rail set and right rail set, as they are different.
2. Position the template at the front of the system to determine the locations of the screws for the rails.

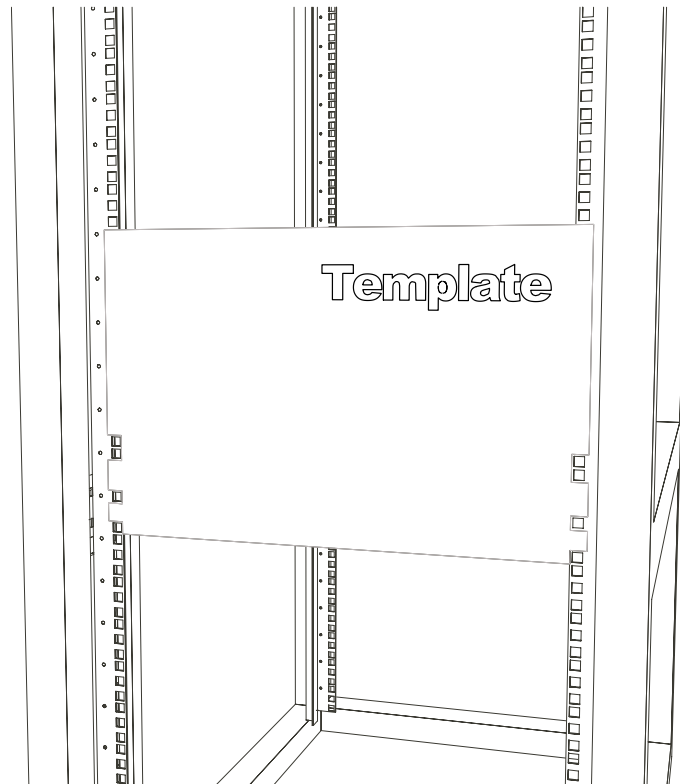

**Figure 2-1. Placing the Template**

3. In each rail set, the two sections are screwed together to keep them immobile during shipping. Release these screws just enough to allow the rail sections to slide apart. Note the arrow on the rail, which indicates the end that attaches to the front of the rack.
4. Slide the rails sections apart to match the depth of the rack. Position the rails with the template and secure the front of each to the front of the rack with two flathead screws, then secure the back of each rail to the rear of the rack with two flathead screws (see Figure 2-2).
5. Tighten the screws that keep the two rail sections from sliding.

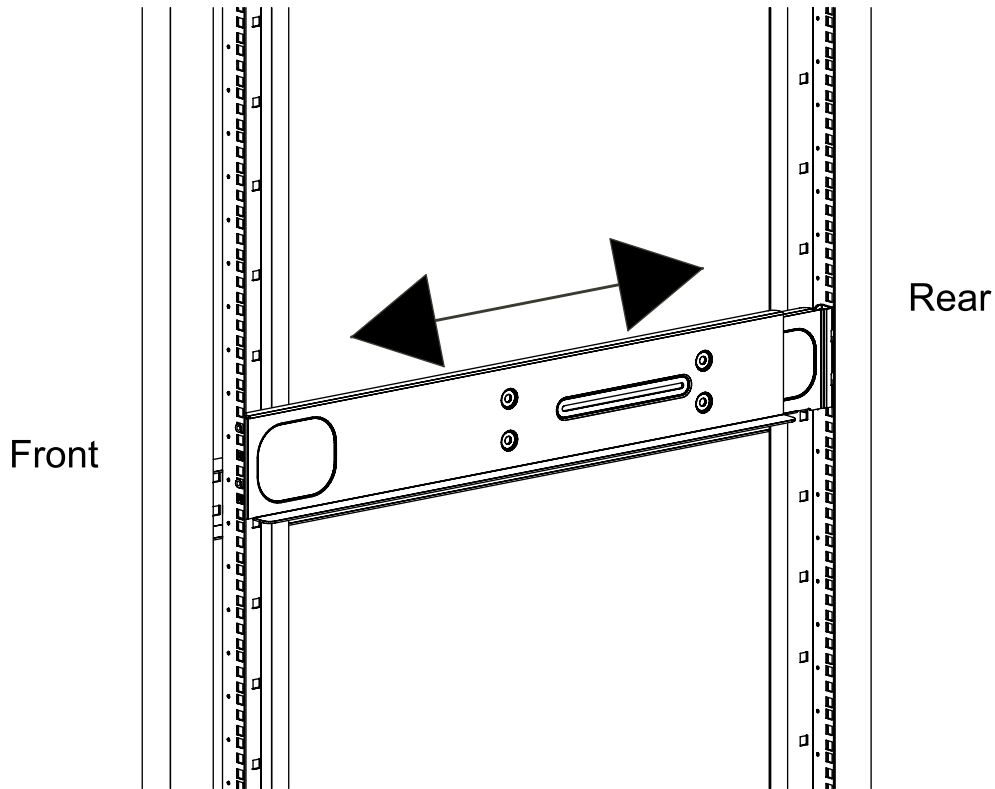

Figure 2-2. Installing the Left Rail

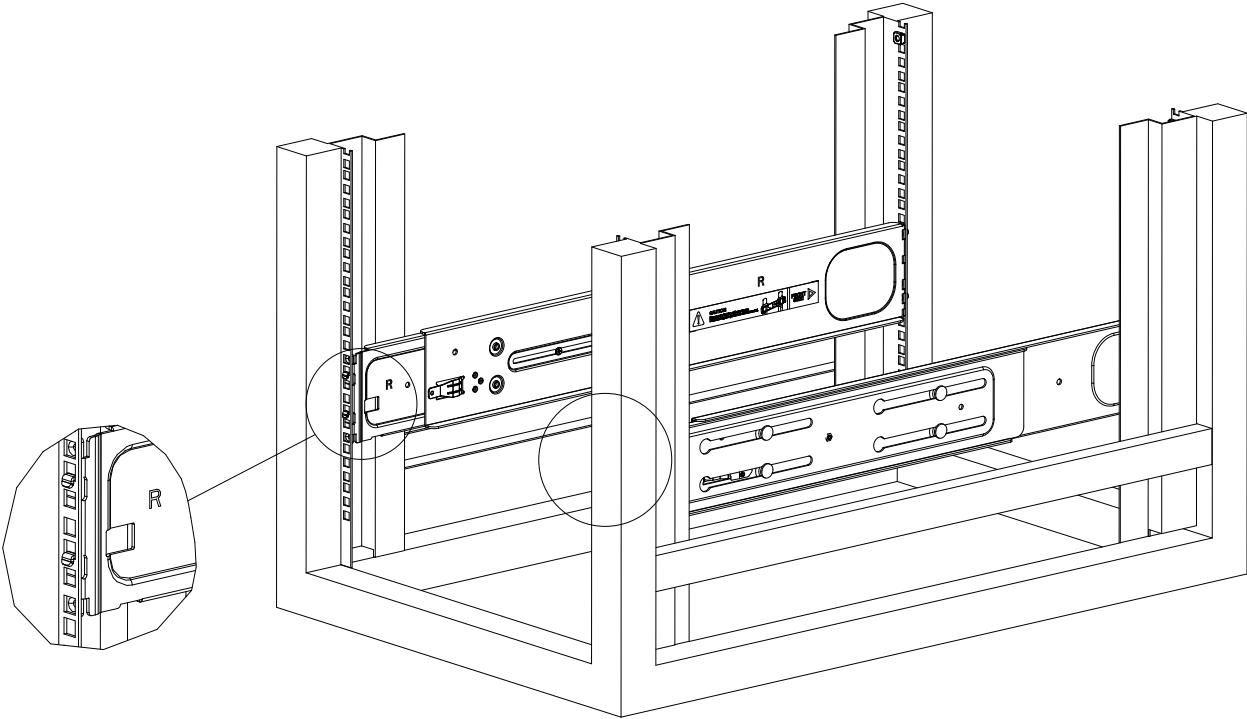

Figure 2-3. Outer Rails Installed on the Rack

## 2.5 Installing the Server



**Warning:** The assembled system is very heavy. Use a lift and multiple people to move it.

1. Using a lift and as many people as necessary, lift the system and slide it onto the installed rails.
2. After pushing the enclosure all the way into the rack, use the thumbscrew on each side of the server to lock it into place.

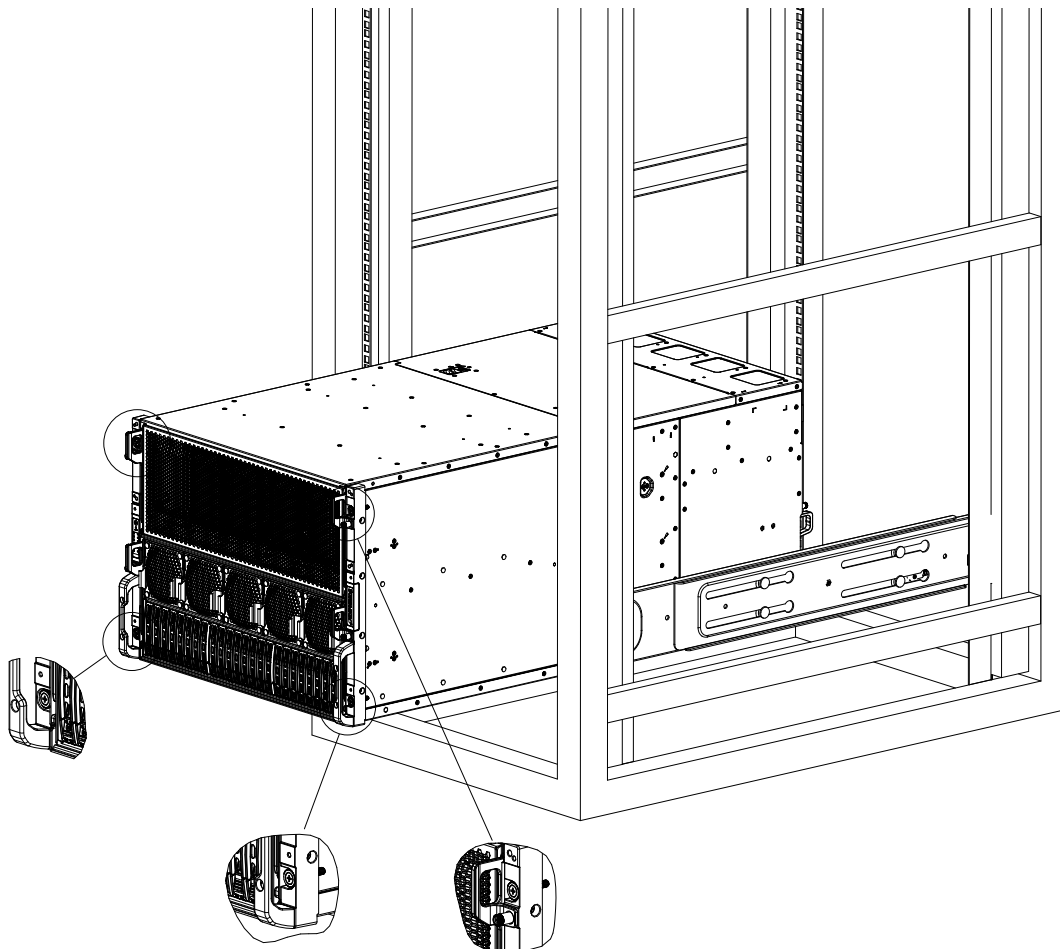

Figure 2-4. Installing the Server onto the Rails

## Chapter 3

# Maintenance and Component Installation

This chapter provides instructions on installing and replacing main system components. To prevent compatibility issues, only use components that match the specifications and/or part numbers given.

Installation or replacement of most components require that power first be removed from the system. Please follow the procedures given in each section.

### 3.1 Removing Power

Use the following procedure to ensure that power has been removed from the system. This step is necessary when removing or installing non hot-swap components or when replacing a non-redundant power supply.

1. Use the operating system to power down the system.
2. After the system has completely shut-down, disconnect the AC power cord(s) from the power strip or outlet. (If your system has more than one power supply, remove the AC power cords from all power supply modules.)
3. Disconnect the power cord(s) from the power supply module(s).

### 3.2 Accessing the System

The system is comprised of several trays. Each tray can be removed from the chassis using release levers.

To replace the trays, be sure the primary handles start in the pulled down position. Once the tray is fully inserted, lift and close the handles to lock the tray in place.



**Warning!** The populated tray is heavy (70 lbs). Use a lift or multiple people to install or remove it.

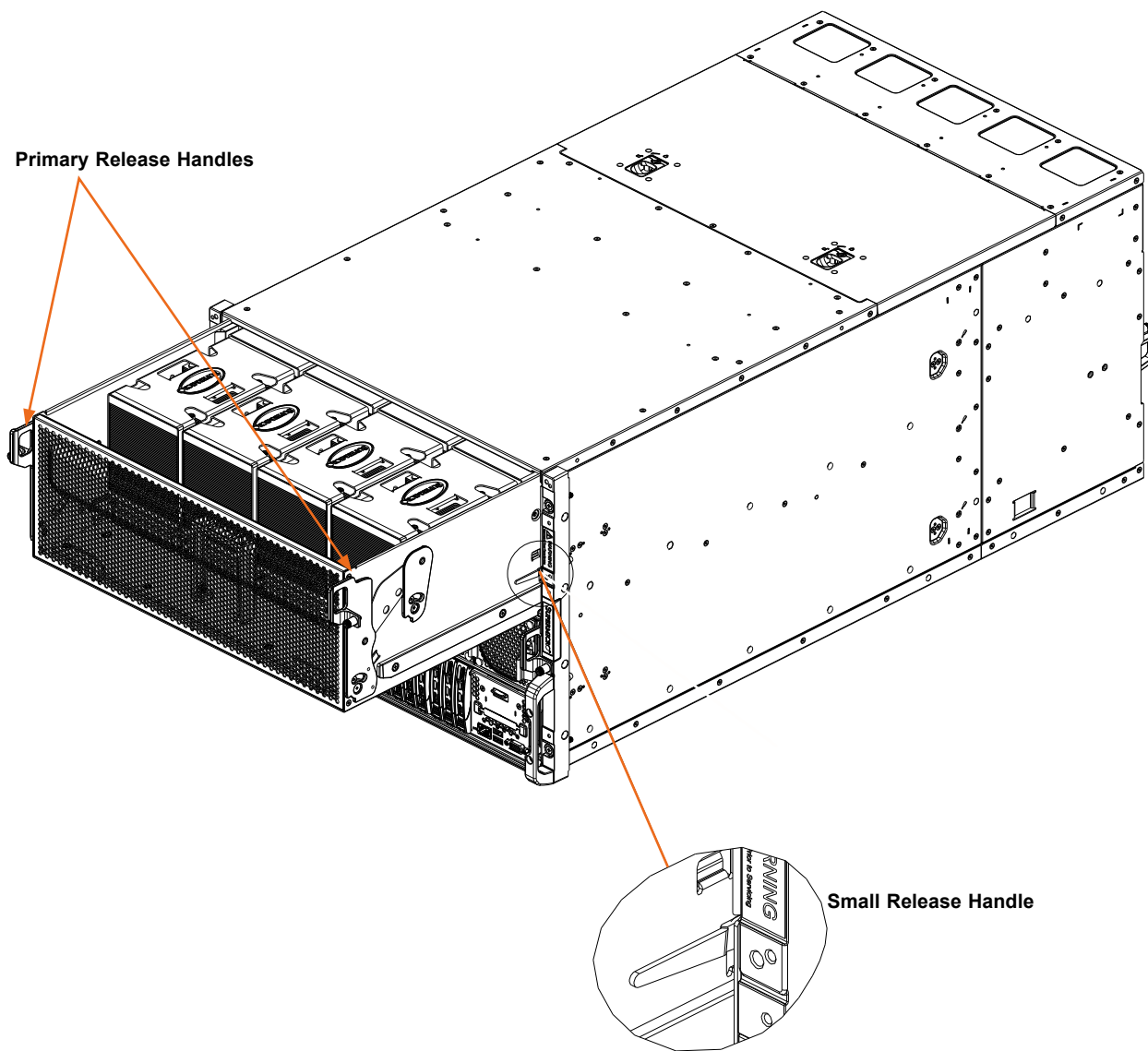

Figure 3-1. Chassis Front, Removing the GPU Tray

### ***Removing the GPU Tray***

1. Power down as described in Section 3.1.
2. Pull down the release handles on each side of the tray, and pull the tray part way out.
3. To fully release the tray, find and depress the the small handles on each side of the tray.

**Caution:** The mid-plane connectors on the rear of the tray are not capable of supporting the weight of the tray. Once the tray is removed from the system, be careful not to lift or tilt the tray so that the connectors are stressed. See the following instructions.



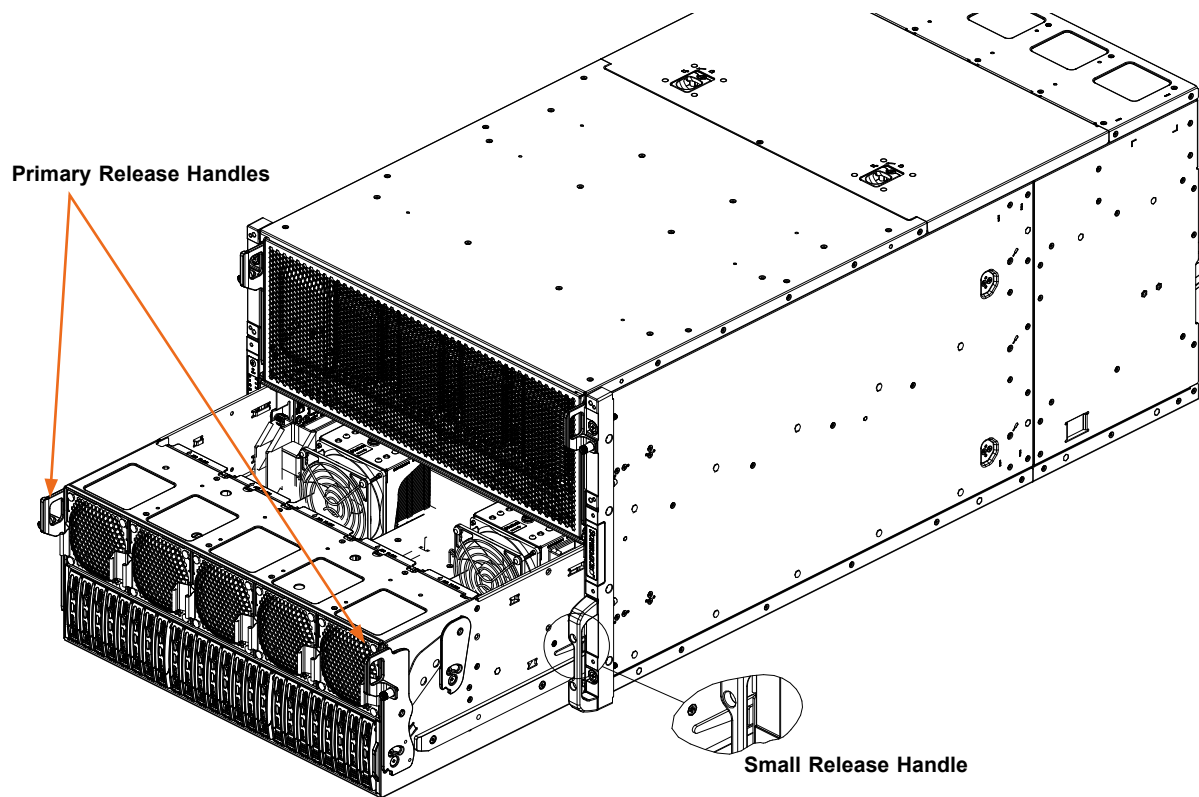

**Figure 3-3. Chassis Front, Removing the Motherboard Tray**



**Warning:** The tray is heavy (70 lbs). Use a lift or multiple people to install or remove it. Do not lift the chassis by the empty motherboard tray slot.

#### ***Removing the Motherboard Tray***

1. Power down as described in Section 3.1.
2. Remove rear PCIe tray. (see the next page)
3. Pull down the release handles on each side of the tray, and pull the tray part way out.
4. To fully release the tray, find and depress the the small handles on the side of each tray.

#### ***Replacing the Motherboard Tray***

1. Be sure the primary handles start in the pulled down position. Once the tray is fully inserted, lift and close the handles to lock the tray in place.
2. Re-insert rear PCIe tray.

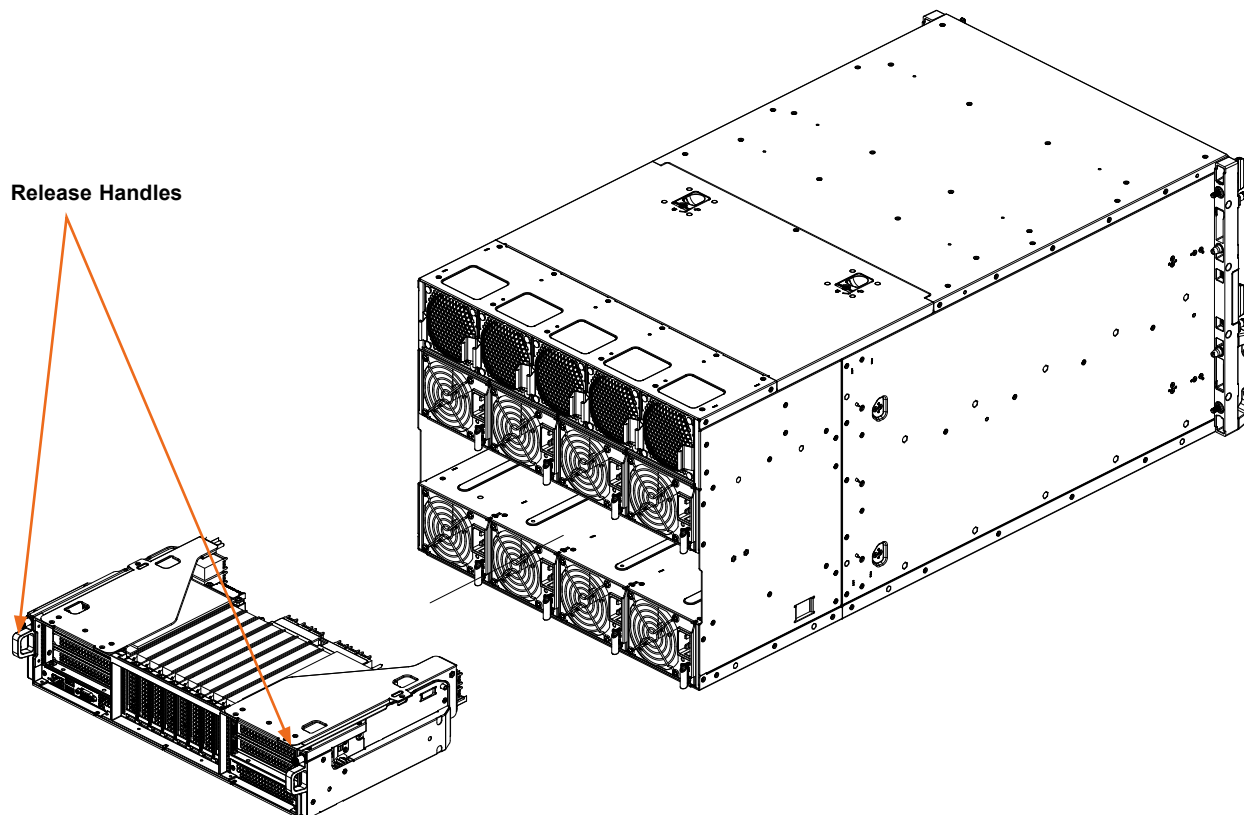

**Figure 3-4. Chassis Rear, Removing the PCIe Expansion Tray**

***Removing the PCIe Expansion Tray***

1. Power down as described in Section 3.1.
2. Pull down the release handles on each side of the tray, and pull the tray out.

**Note:** When replacing trays, insert the front motherboard tray before the PCIe tray.

**Caution:** Do not lift the chassis by the empty PCIe tray slot.

## 3.3 Processor and Heatsink

### Processor Overview

The motherboard supports 4th and 5th Gen Intel Xeon Scalable processors. The models of each differ in the number of cores, and each requires a different CPU carrier. The CPU carriers differ by the presence or absence of shims and levers. Note that the 5th Gen processors do not support the Max Series for high bandwidth memory (HBM) version.

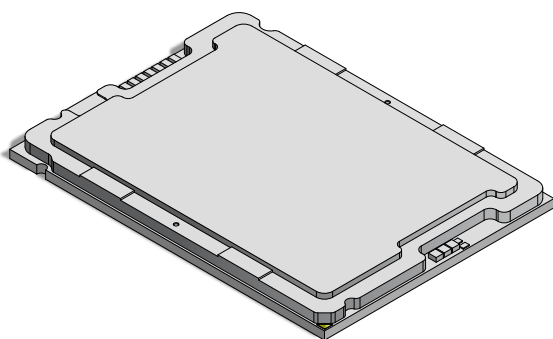

XCC

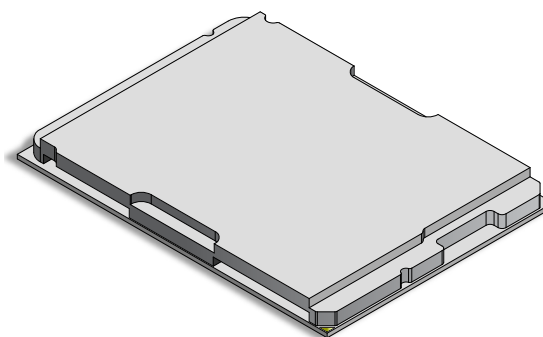

MCC

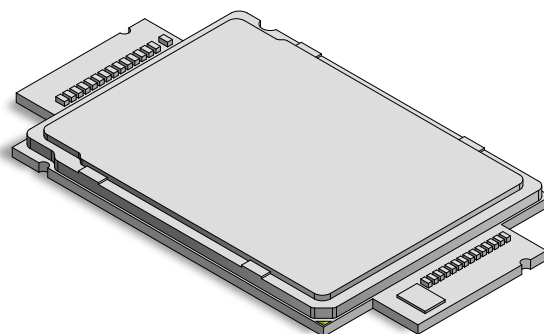

Max

CPU and Carrier Type					
CPU Type	Cores 4th/5th	Carrier Type	Lever	Shim	Carrier Part Number
<b>XCC</b>	60/64	E1A	Yes	No	SKT-1333L-0000-FXC (alt: SKT-1333L-0001-LTS)
<b>MCC</b>	32/36	E1B	Yes	Yes	SKT-1424L-001B-FXC (alt: SKT-1424L-001B-LTS)
<b>Max</b>	56/NA	E1C	No	No	SKT-1425H-001C-FXC (alt: SKT-1425H-001C-LTS)

## **Installation Overview**

The processor (CPU) and processor carrier should be assembled together first to form the processor carrier assembly. This will be attached to the heatsink to form the processor heatsink module (PHM) before being installed onto the CPU socket.

### **Notes:**

- Use ESD protection.
- The system power cords must be removed from all power supplies.
- Check that the plastic protective cover is on the CPU socket and none of the socket pins are bent. If they are, contact your retailer.
- When handling the processor, avoid touching or placing direct pressure on the LGA lands (gold contacts). Improper installation or socket misalignment can cause serious damage to the processor or socket, which may require manufacturer repairs.
- Refer to the Supermicro website for updates on processor support.

## ***Installation Procedure Overview***

After preparing the system, and following ESD precautions, there are four steps to installing the processor and heatsink onto the motherboard.

1. Attach the processor to a plastic carrier to create the processor carrier assembly.
2. Attach the processor carrier assembly to the heatsink to create the processor heatsink module (PHM).
3. Remove the socket cover.
4. Install the PHM.

## Create the Processor Carrier Assembly

### Assembling the Process Carrier Assembly

1. Hold the processor with the gold pins (LGA lands) facing down. Locate the gold triangle at the corner of the processor and the corresponding hollowed triangle on the processor carrier as shown below. These triangles indicate the location of pin 1.

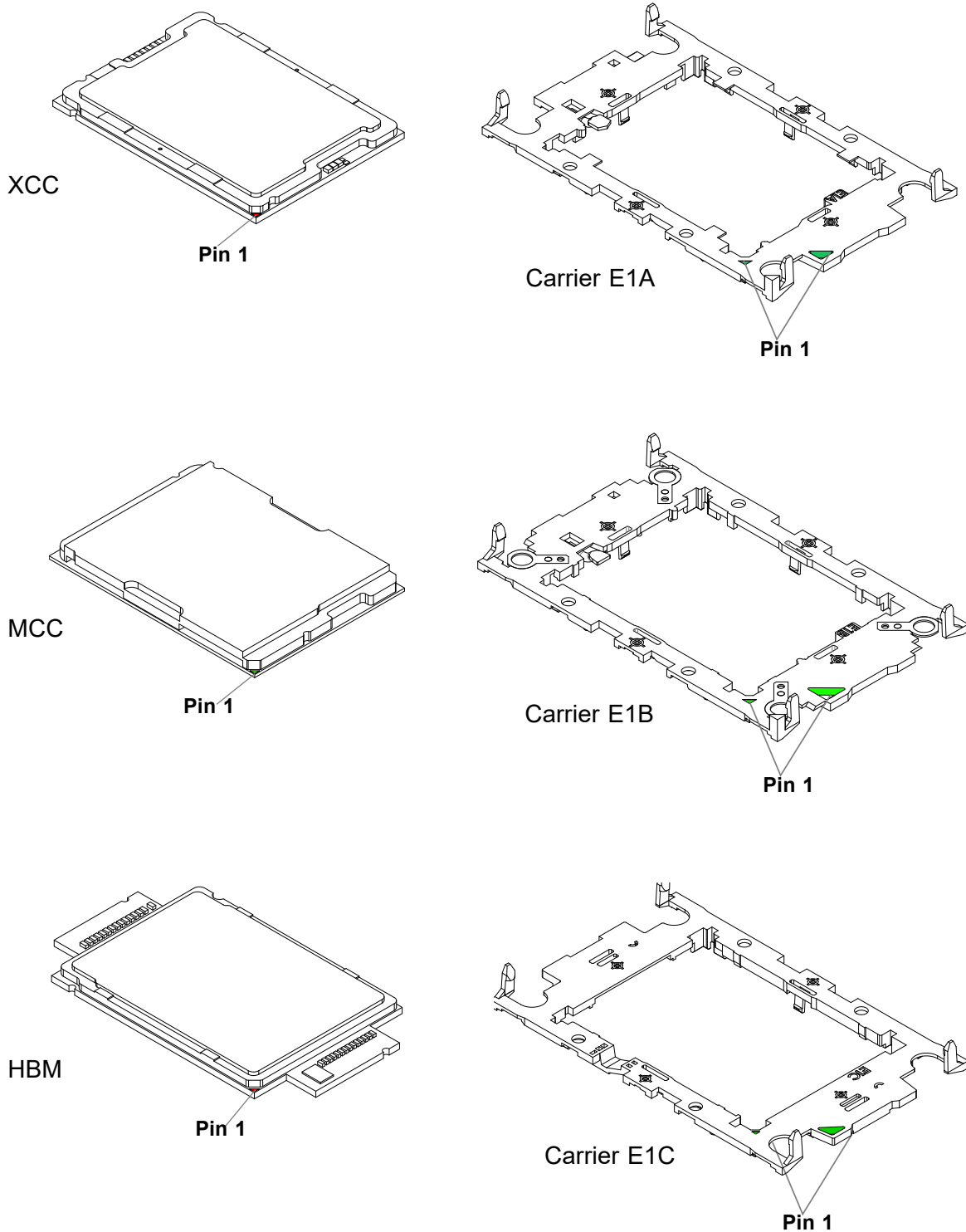

2. Turn the processor over (with the gold pins up). Locate the CPU keys on the processor and the four latches on the carrier.

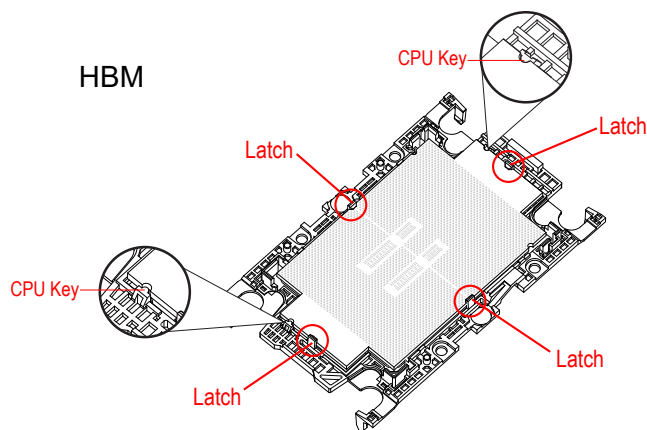
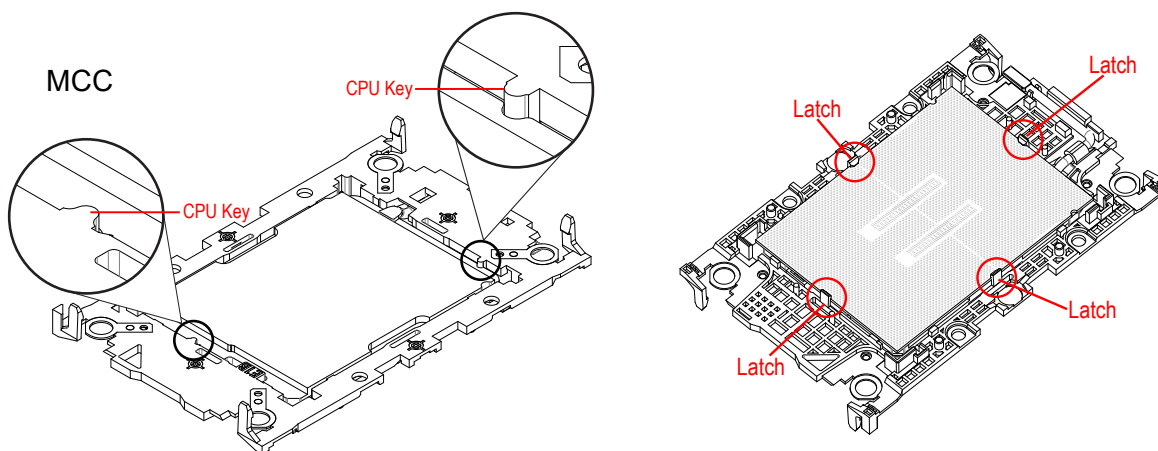
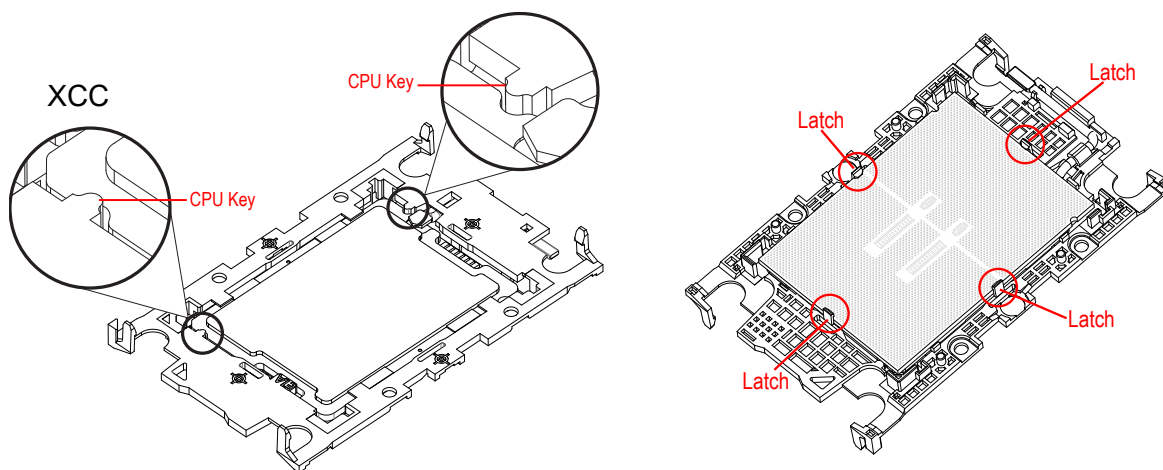

3. Locate the lever on the processor carrier and press it down (E1A and E1B only).

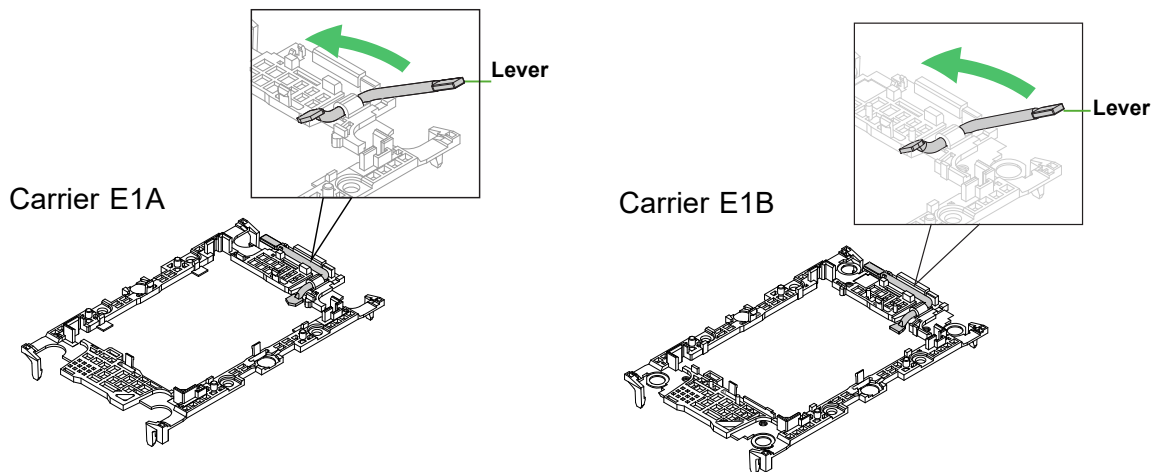

4. Using pin 1 as a guide, carefully align the CPU keys on the processor (A & B) with those on the carrier (a & b).

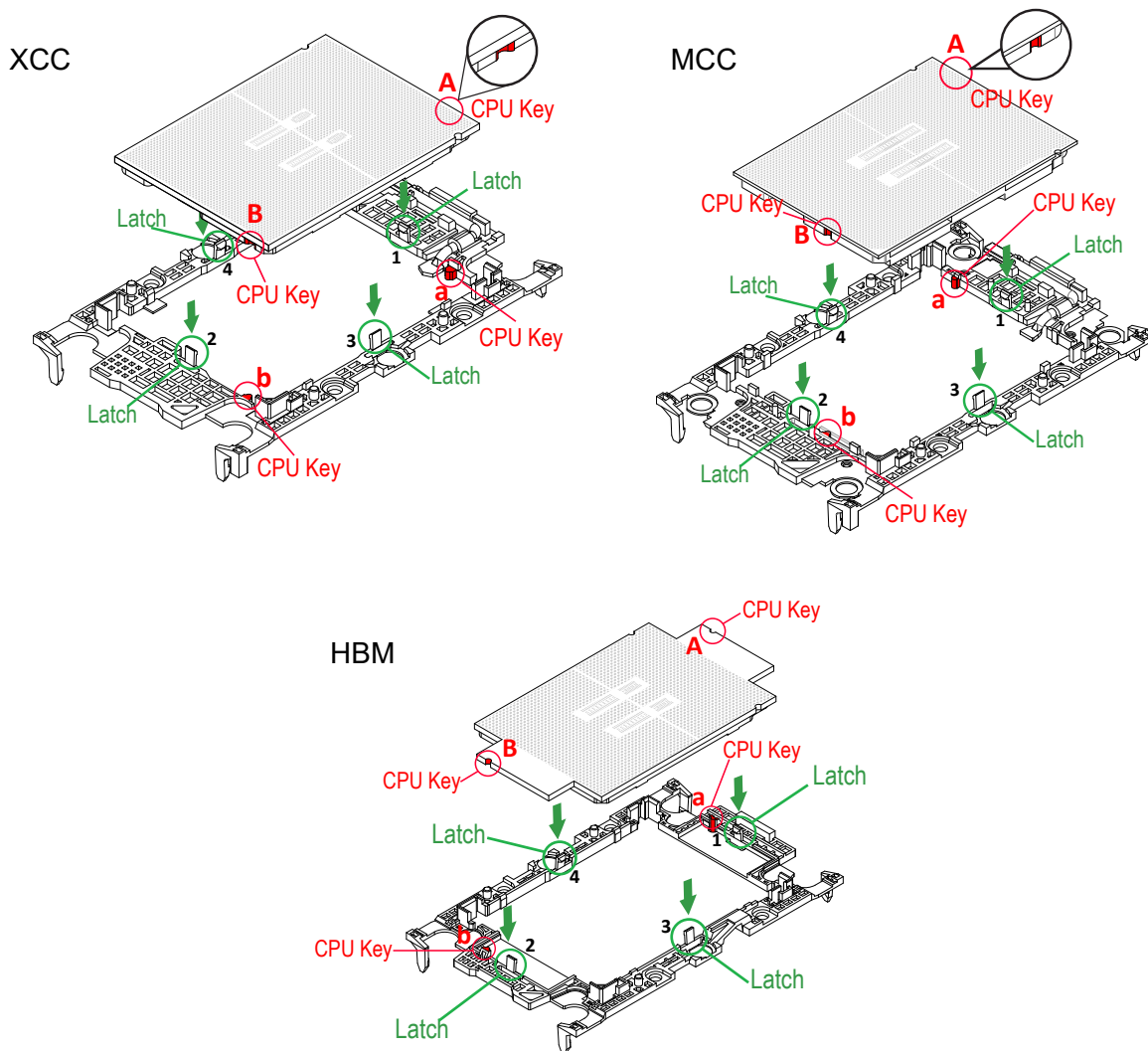

- Once aligned, carefully insert the CPU into the carrier, making sure that the CPU is secured by latches 1, 2, 3, and 4.

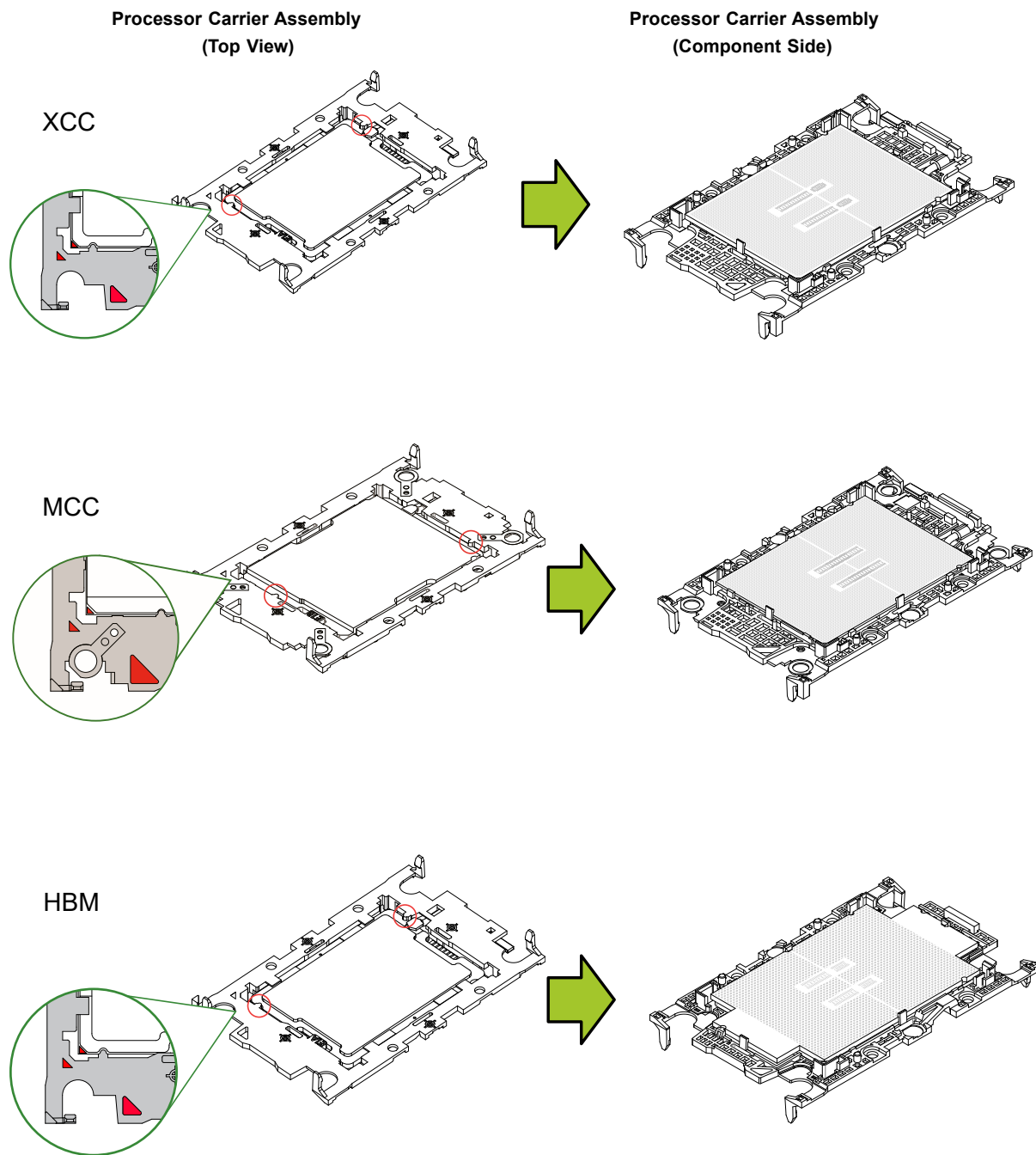

## Assemble the Processor Heatsink Module

Thermal grease is pre-applied on a new heatsink. No additional thermal grease is needed. If this is a re-installation, apply the proper amount of thermal grease to the underside of the heatsink.

### Assembling the Processor Heatsink Module (PHM)

1. Turn the heatsink over with the thermal grease facing up. Locate the two triangle cutouts (A, B) at the diagonal corners of the heatsink as shown in the drawing below.
2. Hold the processor carrier assembly component side up to locate the triangles on the processor and the carrier, which indicate pin 1.
3. Turn the processor carrier assembly over so that the gold pins are facing up, noting the two pin 1 locations ("A" on the processor and "a" on the processor carrier assembly).

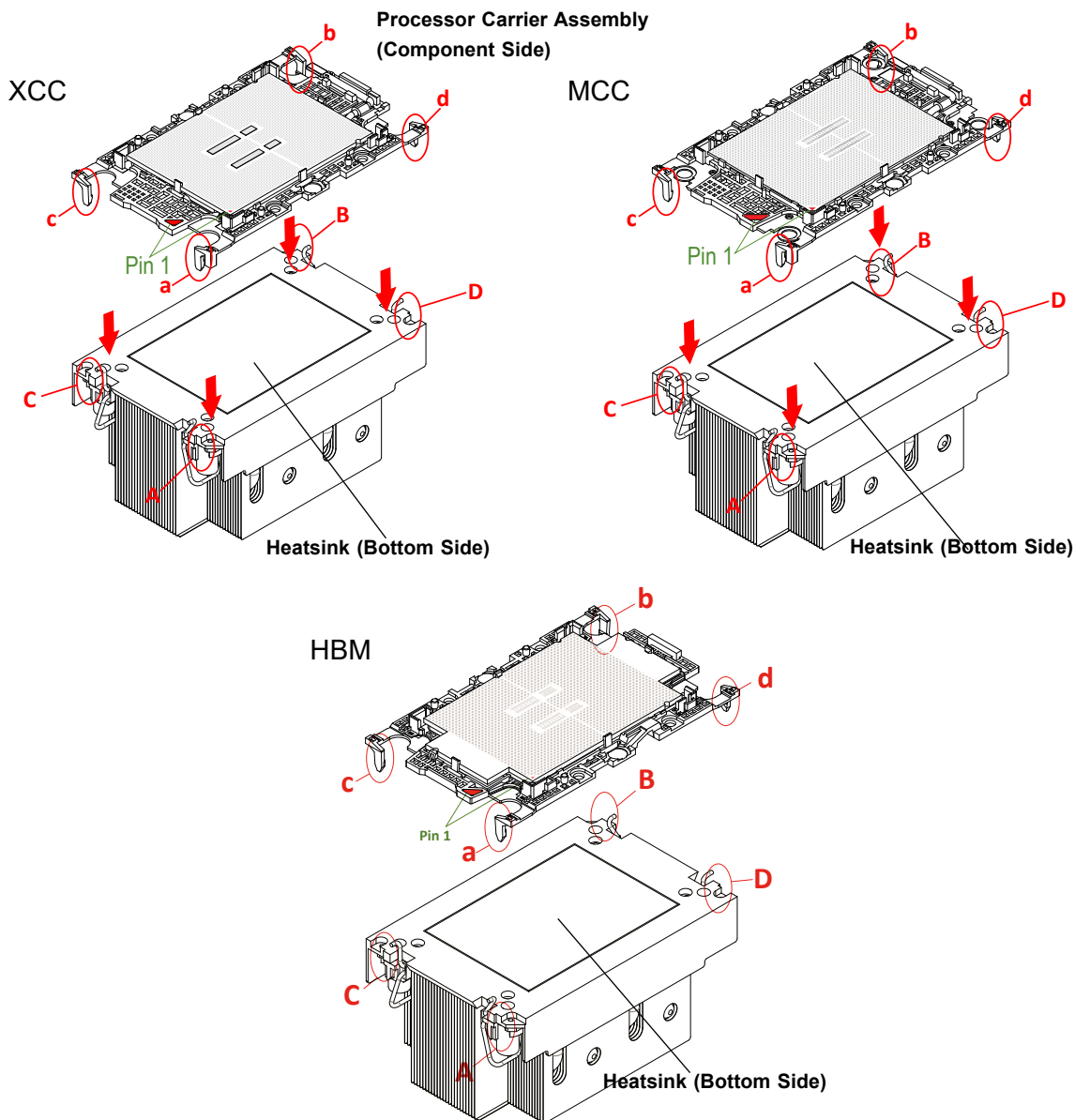

4. Align "a" on the processor carrier assembly with the triangular cutout "A" on the heatsink along with "b", "c", "d" on the processor assembly with "B", "C", "D" on the heatsink.
5. Once properly aligned, place the heatsink on the processor carrier assembly with all corners matched up, making sure that the four clips are properly securing the heatsink.

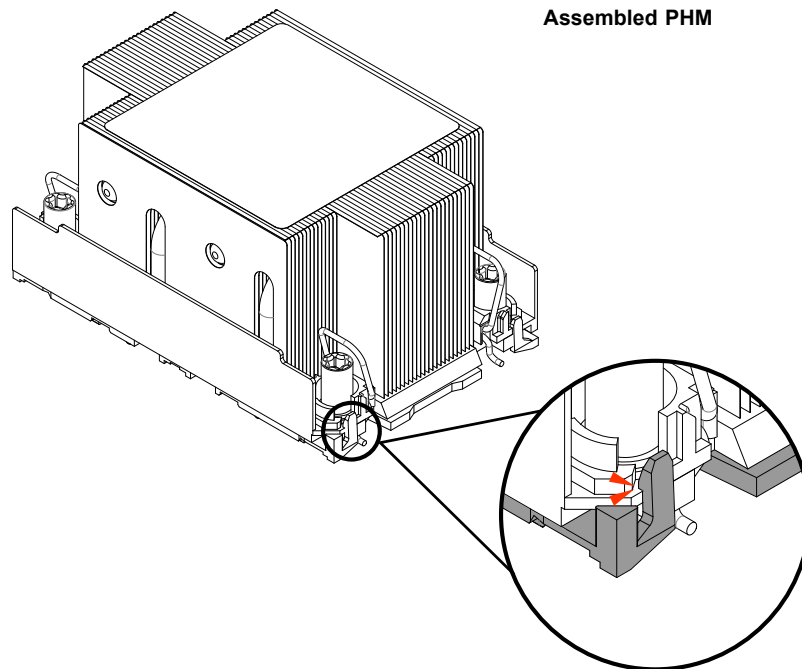

**Note:** The figure is for illustrative purposes. Your components may differ slightly from the components shown.

## Remove the Socket Cover

Remove the plastic protective cover from the socket by gently squeezing the grip tabs and pulling the cover off.

CPU Socket with Plastic Protective Cover

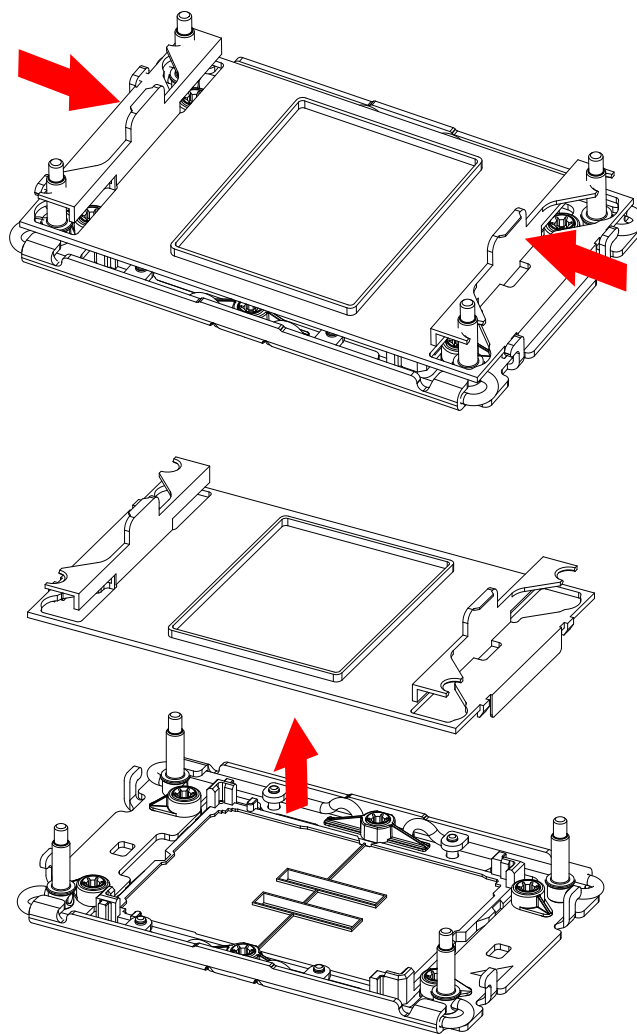

## Install the PHM

To install the PHM into the CPU socket, follow these steps.

1. Locate four threaded fasteners (a, b, c, d) and Pin 1 on the CPU socket.

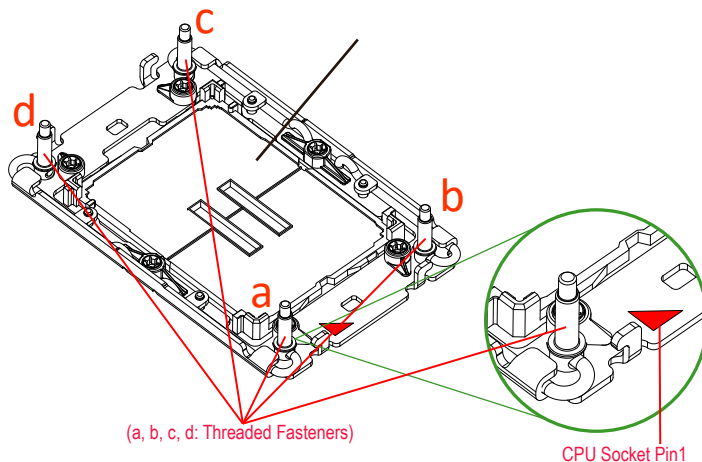

2. Locate four PEEK nuts (A, B, C, D) and four rotating wires (1, 2, 3, 4) on the heatsink.

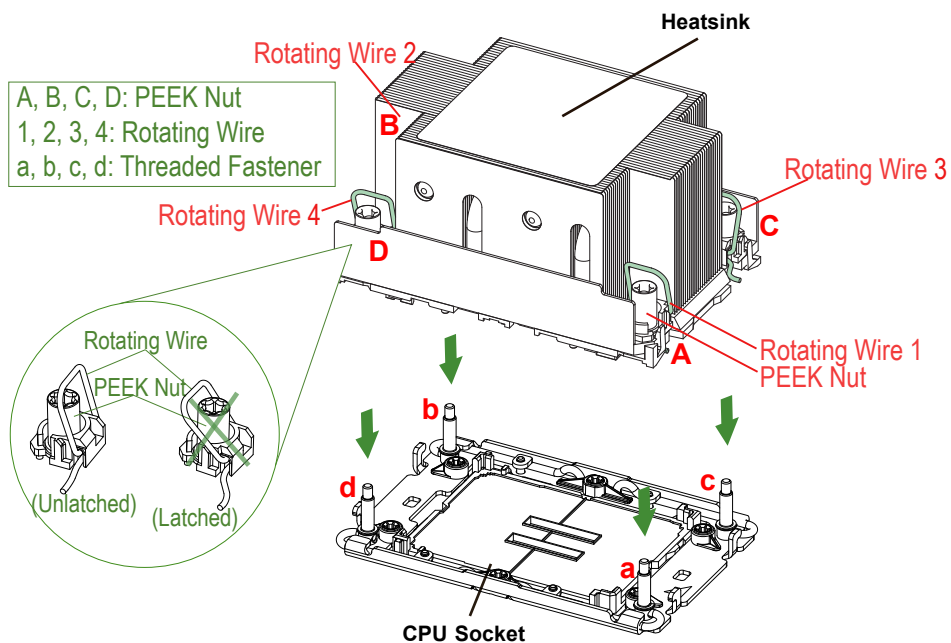

3. Check the rotating wires (1, 2, 3, 4) to make sure that they are in the unlatched position.

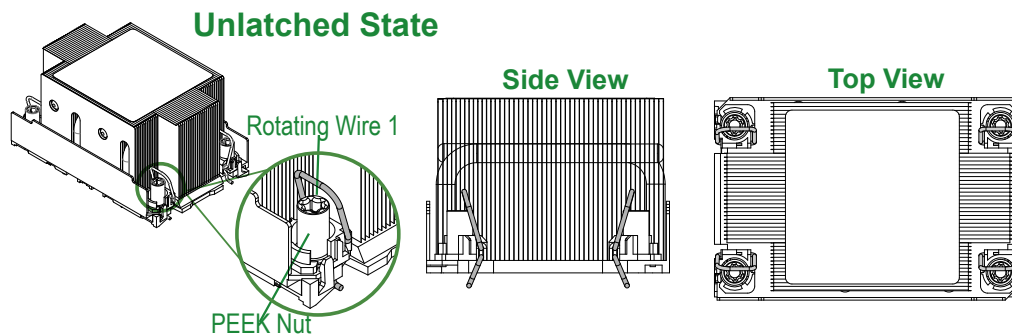

4. Align PEEK nut "A" (next to the triangular pin 1 on the heatsink) with threaded fastener "a" on the CPU socket. Then align PEEK nuts "B", "C", "D" on the heatsink with threaded fasteners "b", "c", "d" on the CPU socket.
5. Once aligned, gently place the PHM on the CPU socket, making sure that each PEEK nut is properly attached to its corresponding threaded fastener.

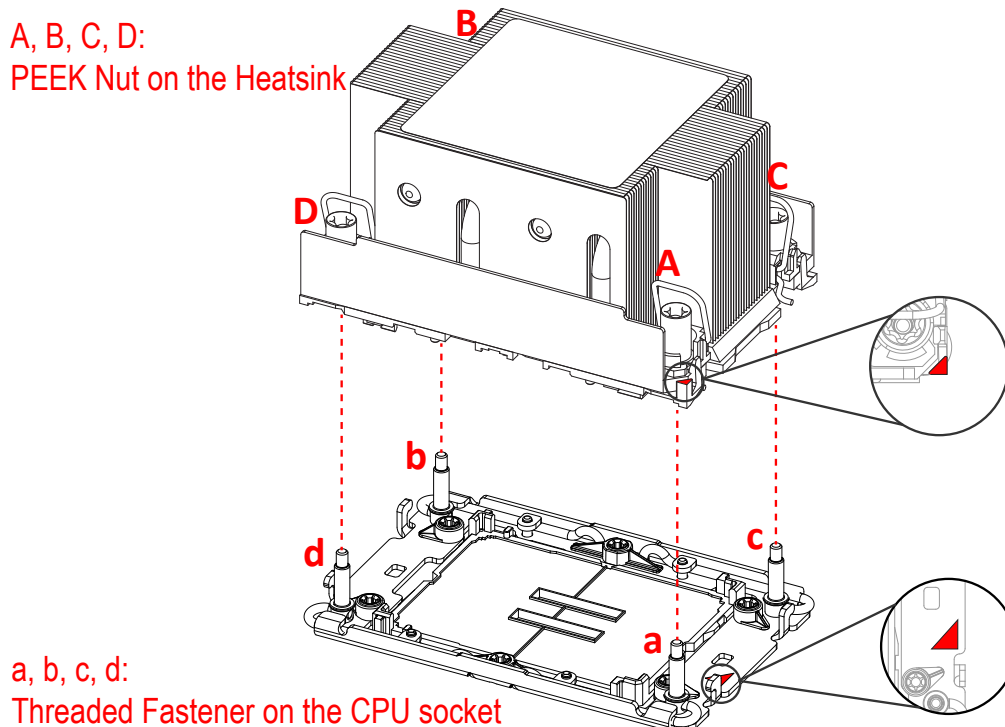

6. Press all four rotating wires outward and make sure that the heatsink is securely latched into the CPU socket.

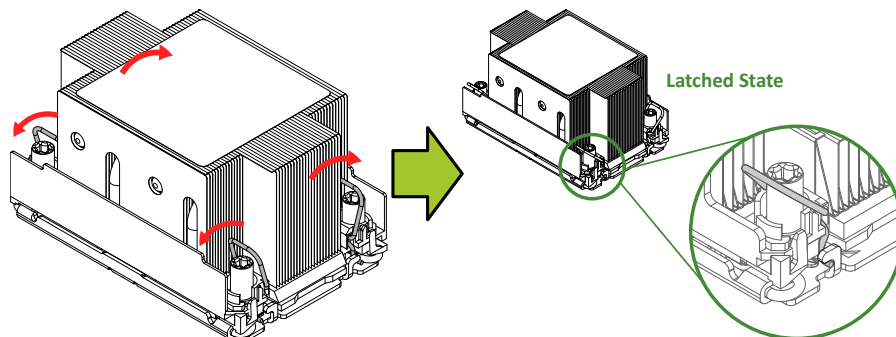

7. With a T30 bit torque driver set to a force of 8.0 in-lbf (0.904 N-m), tighten the PEEK nuts in the sequence of "A", "B", "C", and "D". Note the torque specifications written on the heatsink, and do not exceed them when tightening the screws.
8. Examine all corners of the heatsink to ensure that the PHM is firmly attached to the CPU socket.

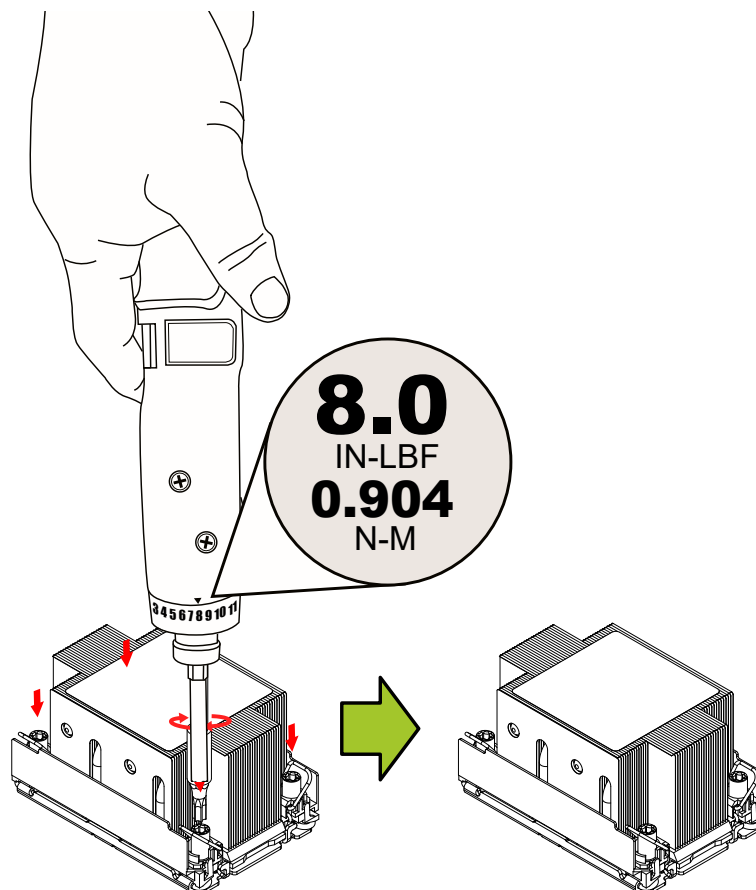

## Removing the PHM

To remove the processor heatsink module (PHM) from the motherboard, follow these steps.

1. Shut down the system and unplug the AC power cord from all power supplies.
2. Use a T30-bit torque driver to loosen the four PEEK nuts on the heatsink in the sequence of A, B, C, and D.

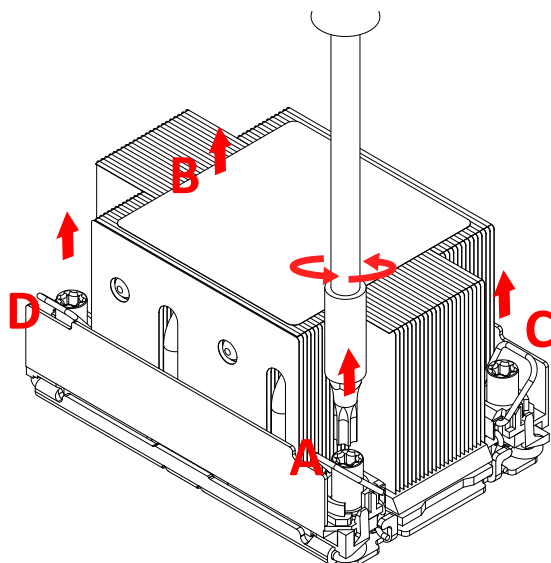

3. Press the rotating wires inward to unlatch the PHM from the socket as shown below.

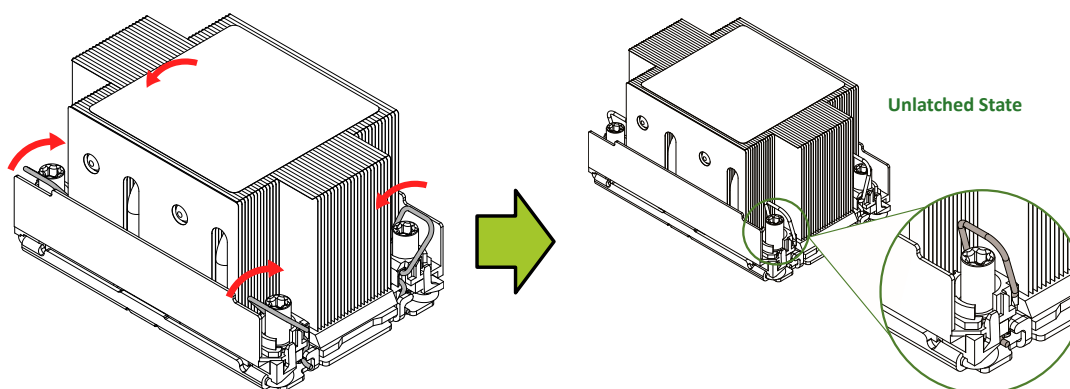

4. Gently lift the PHM upward to remove it from the CPU socket.

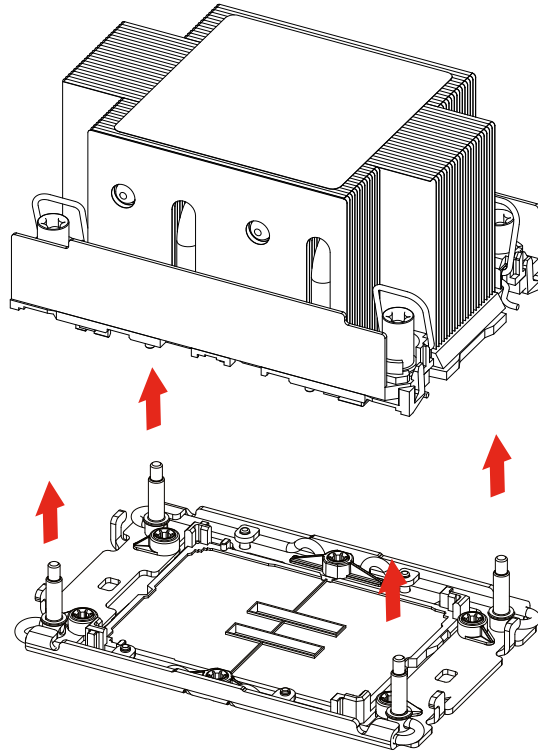

### ***Removing the Carrier Assembly from the Heatsink***

To remove the processor carrier assembly from the PHM, follow these steps:

1. Detach the four plastic clips (marked a, b, c, d) on the processor carrier assembly from the four corners of the heatsink (marked A, B, C, D) as shown below.

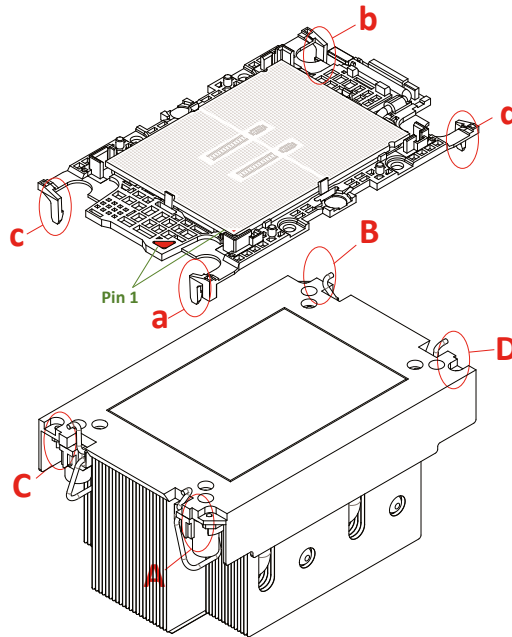

2. When all plastic clips have been detached from the heatsink, remove the processor carrier assembly from the heatsink

### ***Removing the Processor from the Carrier Assembly***

To remove the processor from the processor carrier, follow these steps.

1. Unlock the lever from its locked position and push it upwards to disengage the processor from the processor carrier as shown below right.

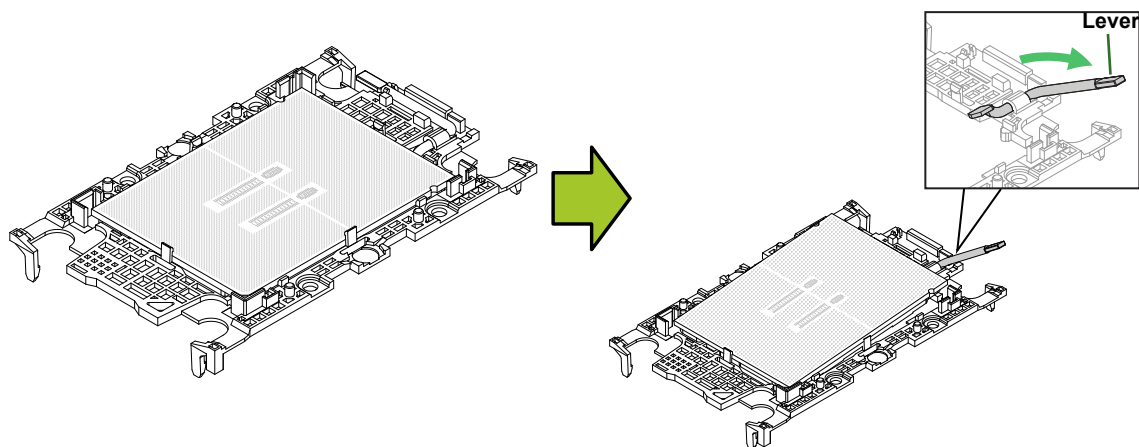

2. Once the processor has been loosened from the carrier, carefully remove the processor from the carrier.

**Note:** Handle the processor with care.

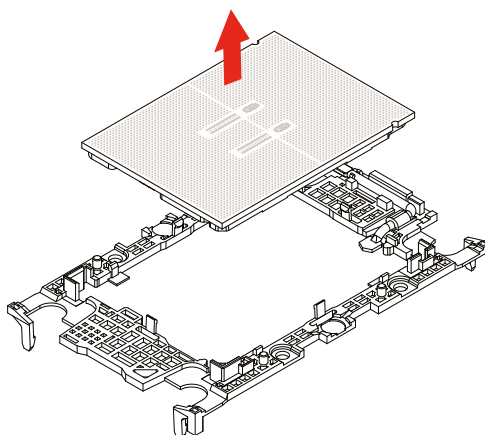

## 3.4 Memory Support and Installation

**Note:** Check the Supermicro website for recommended memory modules and updates on possible memory support.

**Important:** Exercise extreme care when installing or removing DIMM modules to prevent any possible damage.

### Memory Support

This motherboard supports up to 8 TB 3DS RDIMM/RDIMM DDR5 (288-pin) ECC memory with speeds up to 5600 MT/s (1DPC) or 4400 MT/s (2DPC) in 32 DIMM configuration (Note below).

**Note:** Memory speed and capacity support depends on the processors used in the system. The 5<sup>th</sup> Gen. Xeon Scalable processors support DDR5 memory with speeds up to 5600MT/s (or up to 4400 MT/s in 32 DIMM configuration). The 4<sup>th</sup> Gen. Xeon Scalable processors support DDR5 memory with speeds up to 4800 MT/s (or up to 4400 MT/s in 32 DIMM configuration).

### *DDR5 Memory Support for 5<sup>th</sup>/4<sup>th</sup> Gen. Intel Xeon Scalable Processors*

Key Parameters for DIMM Configurations	
Parameters	Possible Values
Number of Channels per Socket	1, 2, 4, 6, 8
Number of DIMMs per Channel	1DPC (1 DIMM Per Channel) or 2DPC (2 DIMMs Per Channel)
DIMM Type	RDIMM and 3DS RDIMM
DIMM Construction	non-3DS RDIMM Raw Cards: A (2Rx4), C (1Rx4), D (1Rx8), E (2Rx8) 3DS RDIMM Raw Cards: A (4Rx4, 8Rx4) 9x4 RDIMM Raw Cards: B (2Rx4), F (1Rx4)

DDR5 Memory Support for the 5 <sup>th</sup> Gen. Intel Xeon Scalable Processors					
Type	Ranks Per DIMM & Data Width (Stack)	DIMM Density and DIMM Capacity		Speed (MT/s); Voltage (V); DIMM Per Channel (DPC)	
				1DPC (Note)	2DPC
		16 Gb	24 Gb	1.1 V	
RDIMM	SRx8 (RC D)	16 GB	24 GB	5600	4400
	SRx4 (RC C)	32 GB	48 GB		
	SRx4 (RC F) 9x4	N/A	N/A		
	DRx8 (RC E)	32 GB	48 GB		
	DRx4 (RC A)	64 GB	96 GB		
	DRx4 (RC B) 9x4	N/A	N/A		
RDIMM 3DS	(4R/8R) x4 (RC A)	2H-128 GB 4H-256 GB	N/A	5600	
LRDIMM/LRDIMM-3DS	N/A	N/A	N/A	Not Supported	Not Supported

**Note 1:** 1DPC (1 DIMM Per Channel) applies to 1SPC (Sockets Per Channel) or 2SPC implementation.

**Note 2:** 24 Gb, 24 GB, and 48 GB DRAM capacity is not supported in 2DPC.

**Note 3:** Memory speed will be 5600 MT/s 1DPC or 4400 MT/s 2DPC.

**Note 4:** For 1DPC 5600 MT/s speed, DDR5-5600 DIMMs are required.

**Note 5:** Mixing DRAM densities (16 Gb/24 Gb) and/or frequencies is not allowed.

DDR5 Memory Support for the 4 <sup>th</sup> Gen. Intel Xeon Scalable Processors					
Type	Ranks Per DIMM & Data Width (Stack)	DIMM Density and DIMM Capacity		Speed (MT/s); Voltage (V); DIMM Per Channel (DPC)	
				1DPC (Note)	2DPC
		16 Gb	24 Gb	1.1 V	
RDIMM	SRx8 (RC D)	16 GB	24 GB	4800	4400
	SRx4 (RC C)	32 GB	48 GB		
	SRx4 (RC F) 9x4	32 GB	N/A		
	DRx8 (RC E)	32 GB	48 GB		
	DRx4 (RC A)	64 GB	96 GB		
	DRx4 (RC B) 9x4	64 GB	N/A		
RDIMM 3DS	(4R/8R) x4 (RC A)	2H-128 GB 4H-256 GB	N/A		
LRDIMM/LRDIMM-3DS	N/A	N/A	N/A	Not Supported	Not Supported

**Note 1:** 1DPC (1 DIMM Per Channel) applies to 1SPC (Sockets Per Channel) or 2SPC implementation.

**Note 2:** 24 Gb XCC only with limited configs: 1DPC all DIMM type, 2DPC 96 GB only. Only 8 and 16 DIMM configs, no fallbacks.

**Note 3:** Memory speed will be 4800 MT/s 1DPC or 4400 MT/s 2DPC.

**Note 4:** Mixing DRAM densities (16 Gb/24 Gb) and/or frequencies is not allowed.

### Memory Population for the X13DEG-M Motherboard (with 32 DIMM Slots)

DDR5 Memory Population Table for the X13DEG-M Motherboard (with 32 DIMM Slots)	
<b>1 CPU:</b>	<b>Memory Population Sequence</b>
<b>1 CPU &amp; 1 DIMM</b>	<b>CPU1:</b> P1-DIMMA1 or P1-DIMME1 or P1-DIMMB1 or P1-DIMMF1
<b>1 CPU &amp; 2 DIMMs</b>	<b>CPU1:</b> P1-DIMMA1 / P1-DIMMG1 or P1-DIMMC1 / P1-DIMME1
<b>1 CPU &amp; 4 DIMMs</b>	<b>CPU1:</b> P1-DIMMA1 / P1-DIMMC1 / P1-DIMME1 / P1-DIMMG1
<b>1 CPU &amp; 6 DIMM</b>	<b>CPU1:</b> P1-DIMMA1 / P1-DIMMC1 / P1-DIMMD1 / P1-DIMME1 / P1-DIMMF1 / P1-DIMMG1 or <b>CPU1:</b> P1-DIMMA1 / P1-DIMMB1 / P1-DIMMC1 / P1-DIMME1 / P1-DIMMG1 / P1-DIMMH1 or <b>CPU1:</b> P1-DIMMB1 / P1-DIMMC1 / P1-DIMMD1 / P1-DIMME1 / P1-DIMMF1 / P1-DIMMH1 or <b>CPU1:</b> P1-DIMMA1 / P1-DIMMB1 / P1-DIMMD1 / P1-DIMMF1 / P1-DIMMG1 / P1-DIMMH1
<b>1 CPU &amp; 8 DIMMs</b>	P1-DIMMA1 / P1-DIMMB1 / P1-DIMMC1 / P1-DIMMD1 / P1-DIMME1 / P1-DIMMF1 / P1-DIMMG1 / P1-DIMMH1
<b>1 CPU &amp; 12 DIMMs</b>	<b>CPU1:</b> P1-DIMMA1 / P1-DIMMA2 / P1-DIMMB1 / P1-DIMMC1 / P1-DIMMC2 / P1-DIMMD1 / P1-DIMME1 / P1-DIMME2 / P1-DIMMF1 / P1-DIMMG1 / P1-DIMMG2 / P1-DIMMH1 or <b>CPU1:</b> P1-DIMMA1 / P1-DIMMB1 / P1-DIMMB2 / P1-DIMMC1 / P1-DIMMD1 / P1-DIMMD2 / P1-DIMME1 / P1-DIMMF1 / P1-DIMMF2 / P1-DIMMG1 / P1-DIMMH1 / P1-DIMMH2
<b>1 CPU &amp; 16 DIMMs</b>	<b>CPU1:</b> P1-DIMMA1 / P1-DIMMA2 / P1-DIMMB1 / P1-DIMMB2 / P1-DIMMC1 / P1-DIMMC2 / P1-DIMMD1 / P1-DIMMD2 / P1-DIMME1 / P1-DIMME2 / P1-DIMMF1 / P1-DIMMF2 / P1-DIMMG1 / P1-DIMMG2 / P1-DIMMH1 / P1-DIMMH2
<b>2 CPUs: (Recommended)</b>	<b>Memory Population Sequence</b>
<b>2 CPUs &amp; 2 DIMMs</b>	<b>CPU1:</b> P1-DIMMA1, <b>CPU2:</b> P2-DIMMA1 or <b>CPU1:</b> P1-DIMME1, <b>CPU2:</b> P2-DIMME1 or <b>CPU1:</b> P1-DIMMB1, <b>CPU2:</b> P2-DIMMB1 or <b>CPU1:</b> P1-DIMMF1, <b>CPU2:</b> P2-DIMMF1
<b>2 CPUs &amp; 4 DIMMs</b>	<b>CPU1:</b> P1-DIMMA1 / P1-DIMMG1, <b>CPU2:</b> P2-DIMMA1 / P2-DIMMG1 or <b>CPU1:</b> P1-DIMMC1 / P1-DIMME1, <b>CPU2:</b> P2-DIMMC1 / P2-DIMME1
<b>2 CPUs &amp; 8 DIMMs</b>	<b>CPU1:</b> P1-DIMMA1 / P1-DIMMC1 / P1-DIMME1 / P1-DIMMG1 <b>CPU2:</b> P2-DIMMA1 / P2-DIMMC1 / P2-DIMME1 / P2-DIMMG1
<b>2 CPUs &amp; 10 DIMMs</b>	<b>CPU1:</b> P1-DIMMA1 / P1-DIMMC1 / P1-DIMMD1 / P1-DIMME1 / P1-DIMMF1 / P1-DIMMG1 <b>CPU2:</b> P2-DIMMA1 / P2-DIMMC1 / P2-DIMME1 / P2-DIMMG1
<b>2 CPUs &amp; 12 DIMMs</b>	<b>CPU1:</b> P1-DIMMA1 / P1-DIMMC1 / P1-DIMMD1 / P1-DIMME1 / P1-DIMMF1 / P1-DIMMG1 <b>CPU2:</b> P2-DIMMA1 / P2-DIMMC1 / P2-DIMMD1 / P2-DIMME1 / P2-DIMMF1 / P2-DIMMG1 or <b>CPU1:</b> P1-DIMMA1 / P1-DIMMB1 / P1-DIMMC1 / P1-DIMME1 / P1-DIMMG1 / P1-DIMMH1 <b>CPU2:</b> P2-DIMMA1 / P2-DIMMB1 / P2-DIMMC1 / P2-DIMME1 / P2-DIMMG1 / P2-DIMMH1 or <b>CPU1:</b> P1-DIMMB1 / P1-DIMMC1 / P1-DIMMD1 / P1-DIMME1 / P1-DIMMF1 / P1-DIMMH1 <b>CPU2:</b> P2-DIMMB1 / P2-DIMMC1 / P2-DIMMD1 / P2-DIMME1 / P2-DIMMF1 / P2-DIMMH1 or <b>CPU1:</b> P1-DIMMA1 / P1-DIMMB1 / P1-DIMMD1 / P1-DIMMF1 / P1-DIMMG1 / P1-DIMMH1 <b>CPU2:</b> P2-DIMMA1 / P2-DIMMB1 / P2-DIMMD1 / P2-DIMMF1 / P2-DIMMG1 / P2-DIMMH1
<b>2 CPUs &amp; 16 DIMMs</b>	<b>CPU1:</b> P1-DIMMA1 / P1-DIMMB1 / P1-DIMMC1 / P1-DIMMD1 / P1-DIMME1 / P1-DIMMF1 / P1-DIMMG1 / P1-DIMMH1 <b>CPU2:</b> P2-DIMMA1 / P2-DIMMB1 / P2-DIMMC1 / P2-DIMMD1 / P2-DIMME1 / P2-DIMMF1 / P2-DIMMG1 / P2-DIMMH1
<b>2 CPUs &amp; 22 DIMMs</b>	<b>CPU1:</b> P1-DIMMA1 / P1-DIMMA2 / P1-DIMMB1 / P1-DIMMB2 / P1-DIMMC1 / P1-DIMMC2 / P1-DIMMD1 / P1-DIMMD2 / P1-DIMME1 / P1-DIMME2 / P1-DIMMF1 / P1-DIMMF2 / P1-DIMMG1 / P1-DIMMG2 / P1-DIMMH1 / P1-DIMMH2 <b>CPU2:</b> P2-DIMMA1 / P2-DIMMC1 / P2-DIMMD1 / P2-DIMME1 / P2-DIMMF1 / P2-DIMMG1
<b>2 CPUs &amp; 24 DIMMs</b>	<b>CPU1:</b> P1-DIMMA1 / P1-DIMMA2 / P1-DIMMB1 / P1-DIMMB2 / P1-DIMMC1 / P1-DIMMC2 / P1-DIMMD1 / P1-DIMMD2 / P1-DIMME1 / P1-DIMME2 / P1-DIMMF1 / P1-DIMMF2 / P1-DIMMG1 / P1-DIMMG2 / P1-DIMMH1 / P1-DIMMH2 <b>CPU2:</b> P2-DIMMA1 / P2-DIMMB1 / P2-DIMMC1 / P2-DIMMD1 / P2-DIMME1 / P2-DIMMF1 / P2-DIMMG1 / P2-DIMMH1
<b>2 CPUs &amp; 32 DIMMs</b>	<b>CPU1:</b> P1-DIMMA1 / P1-DIMMA2 / P1-DIMMB1 / P1-DIMMB2 / P1-DIMMC1 / P1-DIMMC2 / P1-DIMMD1 / P1-DIMMD2 / P1-DIMME1 / P1-DIMME2 / P1-DIMMF1 / P1-DIMMF2 / P1-DIMMG1 / P1-DIMMG2 / P1-DIMMH1 / P1-DIMMH2 <b>CPU2:</b> P2-DIMMA1 / P2-DIMMA2 / P2-DIMMB1 / P2-DIMMB2 / P2-DIMMC1 / P2-DIMMC2 / P2-DIMMD1 / P2-DIMMD2 / P2-DIMME1 / P2-DIMME2 / P2-DIMMF1 / P2-DIMMF2 / P2-DIMMG1 / P2-DIMMG2 / P2-DIMMH1 / P2-DIMMH2

**Note:** This memory configuration is recommended by Supermicro for optimal memory performance. Please use this configuration to maximize your memory performance.

DDR5 Memory Population Table for HMB CPU 32-DIMM Motherboards	
<b>1 CPU:</b>	<b>Memory Population Sequence</b>
<b>1 CPU &amp; 1 DIMM</b>	P1-DIMMA1 or P1-DIMME1
<b>1 CPU &amp; 2 DIMMs</b>	P1-DIMMA1 / P1-DIMMG1 or P1-DIMMC1 / P1-DIMME1
<b>1 CPU &amp; 4 DIMMs</b>	P1-DIMMA1 / P1-DIMMC1 / P1-DIMME1 / P1-DIMMG1
<b>1 CPU &amp; 8 DIMMs</b>	P1-DIMMA1/P1-DIMMB1 / P1-DIMMC1 / P1-DIMMD1 / P1-DIMME1 / P1-DIMMF1 / P1-DIMMG1 / P1-DIMMH1
<b>1 CPU &amp; 16 DIMMs</b>	P1-DIMMA1 / P1-DIMMA2 / P1-DIMMB1 / P1-DIMMB2 / P1-DIMMC1 / P1-DIMMC2 / P1-DIMMD1 / P1-DIMMD2 / P1-DIMME1 / P1-DIMME2 / P1-DIMMF1 / P1-DIMMF2 / P1-DIMMG1 / P1-DIMMG2 / P1-DIMMH1 / P1-DIMMH2
<b>2 CPUs: (Recommended)</b>	<b>Memory Population Sequence</b>
<b>2 CPUs &amp; 2 DIMMs</b>	<b>CPU1:</b> P1-DIMMA1, <b>CPU2:</b> P2-DIMMA1 or <b>CPU1:</b> P1-DIMME1, <b>CPU2:</b> P2-DIMME1
<b>2 CPUs &amp; 4 DIMMs</b>	<b>CPU1:</b> P1-DIMMA1 / P1-DIMMG1, <b>CPU2:</b> P2-DIMMA1 / P2-DIMMG1 or <b>CPU1:</b> P1-DIMMC1 / P1-DIMME1, <b>CPU2:</b> P2-DIMMC1 / P2-DIMME1
<b>2 CPUs &amp; 8 DIMMs</b>	<b>CPU1:</b> P1-DIMMA1 / P1-DIMMC1 / P1-DIMME1 / P1-DIMMG1 or <b>CPU2:</b> P2-DIMMA1 / P2-DIMMC1 / P2-DIMME1 / P2-DIMMG1
<b>2 CPUs &amp; 16 DIMMs</b>	<b>CPU1:</b> P1-DIMMA1 / P1-DIMMB1 / P1-DIMMC1 / P1-DIMMD1 / P1-DIMME1 / P1-DIMMF1 / P1-DIMMG1 / P1-DIMMH1 or <b>CPU2:</b> P2-DIMMA1 / P2-DIMMB1 / P2-DIMMC1 / P2-DIMMD1 / P2-DIMME1 / P2-DIMMF1 / P2-DIMMG1 / P2-DIMMH1
<b>2 CPUs &amp; 32 DIMMs</b>	<b>CPU1:</b> P1-DIMMA1 / P1-DIMMA2 / P1-DIMMB1 / P1-DIMMB2 / P1-DIMMC1 / P1-DIMMC2 / P1-DIMMD1 / P1-DIMMD2 / P1-DIMME1 / P1-DIMME2 / P1-DIMMF1 / P1-DIMMF2 / P1-DIMMG1 / P1-DIMMG2 / P1-DIMMH1 / P1-DIMMH2 <b>CPU2:</b> P2-DIMMA1 / P2-DIMMA2 / P2-DIMMB1 / P2-DIMMB2 / P2-DIMMC1 / P2-DIMMC2 / P2-DIMMD1 / P2-DIMMD2 / P2-DIMME1 / P2-DIMME2 / P2-DIMMF1 / P2-DIMMF2 / P2-DIMMG1 / P2-DIMMG2 / P2-DIMMH1 / P2-DIMMH2

### Notes:

- Max Series (HBM) processors support 1DPC (4800 MT/s) / 2DPC (4400 MT/s) to optimize the memory bandwidth. Max Series (HBM) processors support 1, 2, 4, 8, or 16 DIMMs in Flat Mode and Cache Mode, and 0 DIMMs in HBM-Only mode. HBM-Only mode runs exclusively using HBM memory.
- For the best memory performance in Flat mode and Cache mode, please use 4, 8, or 16 DIMM configurations. (At least one DIMM per memory controller for balanced configuration)
  - 4 DIMMs -> populate 1 DIMM/iMC
  - 8 DIMMs -> populate 1 DIMM/Channel, 2 DIMM/iMC
  - 16 DIMMs -> populate 2 DIMM/Channel, 4 DIMM/iMC
- All other configurations not listed above are not supported.
- For a dual-socket design, each socket has to be populated identically.

## Memory Slots

This motherboard supports up to 8 TB of DDR5 memory in 32 slots. Please refer to the layout drawing below for the locations of the DIMM slots:

<b>DIMM Slots Supported by CPU1</b>	<b>DIMM Slots Supported by CPU2</b>
P1-DIMMA1	P2-DIMMA1
P1-DIMMA2	P2-DIMMA2
P1-DIMMB1	P2-DIMMB1
P1-DIMMB2	P2-DIMMB2
P1-DIMMC1	P2-DIMMC1
P1-DIMMC2	P2-DIMMC2
P1-DIMMD1	P2-DIMMD1
P1-DIMMD2	P2-DIMMD2
P1-DIMME1	P2-DIMME1
P1-DIMME2	P2-DIMME2
P1-DIMMF1	P2-DIMMF1
P1-DIMMF2	P2-DIMMF2
P1-DIMMG1	P2-DIMMG1
P1-DIMMG2	P2-DIMMG2
P1-DIMMH1	P2-DIMMH1
P1-DIMMH2	P2-DIMMH2

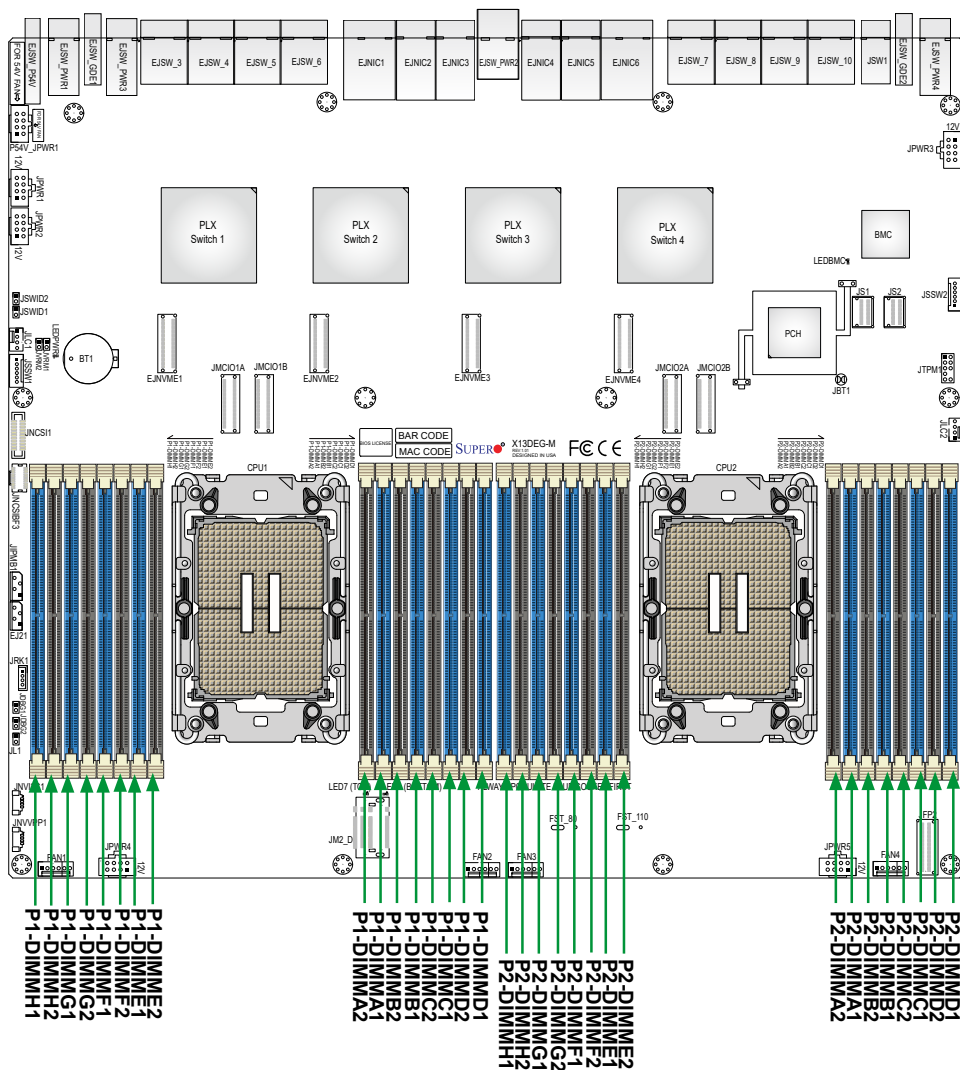
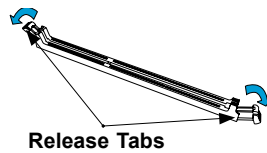
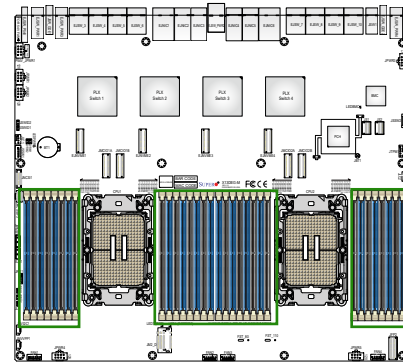

Figure 3-5. DIMM Numbering

## DIMM Installation

**Note:** The DDR5 DIMM module is **NOT** hot-swap and be sure to disconnect power for a minimum of 20 seconds before inserting or removing it.

1. Insert the desired number of DIMMs into the memory slots based on the recommended DIMM population tables in the previous section. Locate DIMM memory slots on the motherboard as shown on the right.



2. Push the release tabs outwards on both ends of the DIMM slot to unlock it.

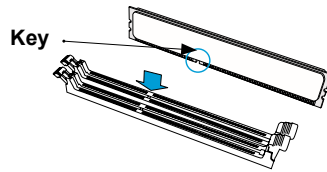

3. Align the key of the memory module with the DIMM socket key on the memory slot.

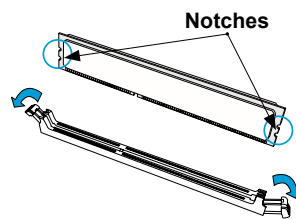

4. Align the notches on both ends of the module against the latches on the ends of the slot.
5. Push both ends of the module straight down into the slot until the module snaps into place.
6. Press the release tabs to the lock positions to secure the memory module into the slot.

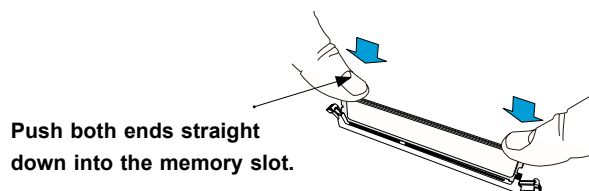

## DIMM Removal

Press both release tabs on the ends of the memory module to unlock it. Once the memory module has been loosened, remove it from the memory slot.

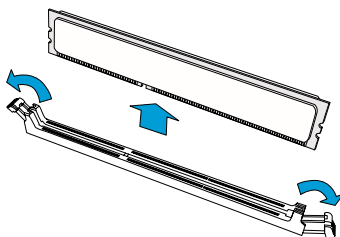

**Note:** Removing a DDR5 DIMM module at a slant angle will cause module damages. It is strongly recommended that you lift the module straight up out of the slot.

**Warning!** Please do not use excessive force when pressing the release tabs on the ends of the DIMM socket to avoid causing any damage to the memory module or the DIMM socket. Please handle memory modules with care. Carefully follow all the instructions given on page 24 to avoid ESD-related damages done to your memory modules or components.

## Motherboard Battery

The motherboard uses non-volatile memory to retain system information when system power is removed. This memory is powered by a lithium battery residing on the motherboard.

### *Replacing the Battery*

Begin by removing power from the system as described in Section 3.1.

1. Push aside the small clamp that covers the edge of the battery. When the battery is released, lift it out of the holder.
2. To insert a new battery, slide one edge under the lip of the holder with the positive (+) side facing up. Then push the other side down until the clamp snaps over it.

**Note:** Handle used batteries carefully. Do not damage the battery in any way; a damaged battery may release hazardous materials into the environment. Do not discard a used battery in the garbage or a public landfill. Please comply with the regulations set up by your local hazardous waste management agency to dispose of your used battery properly.

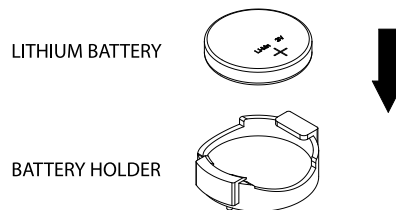

**Figure 3-6. Installing the Onboard Battery**

**Warning:** There is a danger of explosion if the onboard battery is installed upside down (which reverses its polarities). This battery must be replaced only with the same or an equivalent type recommended by the manufacturer (CR2032).

## 3.5 Storage Drives

The system supports sixteen 2.5" NVMe storage drives and three 2.5" SATA storage drives. (An option with more drives is available.) The drives are mounted in tool-less drive carriers that simplify their removal from the chassis. These carriers also help promote proper airflow. Drive carrier status indicators are described in Section 1.2.

**Note:** Enterprise level storage drives are recommended for use in Supermicro servers. For compatible storage drives, see the [system web page](#).

**Note:** Do not mix NVMe drive vendors in the front bays.

### Installing Hot-Swap Drives

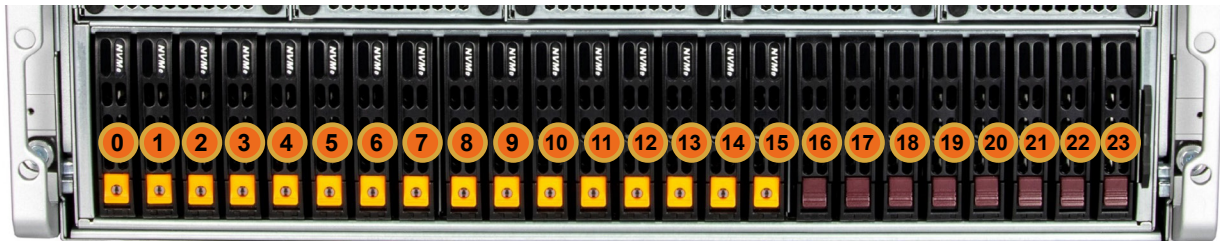

Figure 3-7. Logical Drive Numbers

Logical Storage Drive Numbers	
Item	Description
0 to 11	Twelve 2.5-inch hot-swap NVMe drive bays
12 to 15	(Optional) Four 2.5-inch hot-swap NVMe drive bays (optional)
16 to 23	Eight 2.5-inch hot-swap SATA drive bays

To install drives, first remove the drive carrier from the system.

***Removing a Hot-Swap Drive Carrier***

1. Press the release button on the drive carrier, which will extend the drive carrier handle.
2. Use the drive carrier handle to pull the drive out of the chassis.

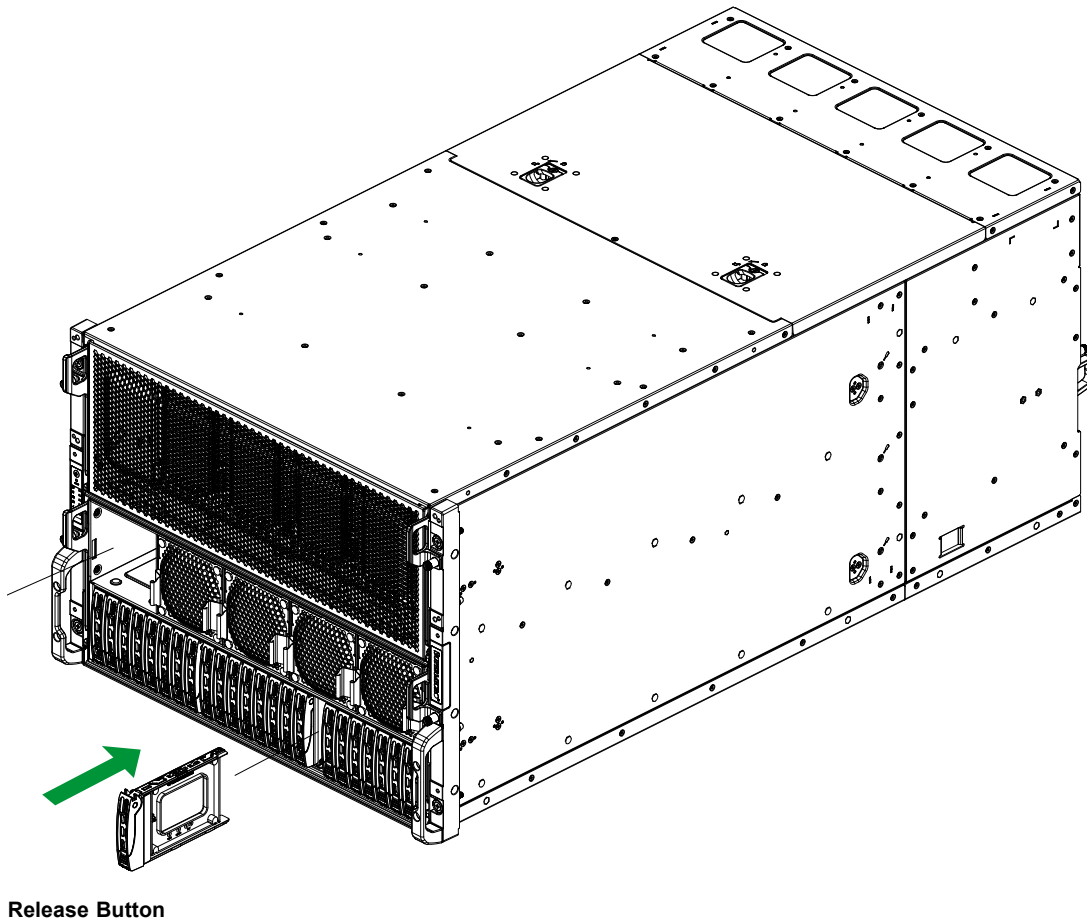

**Figure 3-8. Removing a Drive Carrier**

### Installing a Drive

1. Remove the dummy drive, which comes pre-installed in the drive carrier. Pull out the two locking clasps on the left outside of the carrier and lift out the dummy drive.
2. Position the drive above the carrier with the PCB side facing down and the connector end toward the rear of the carrier.

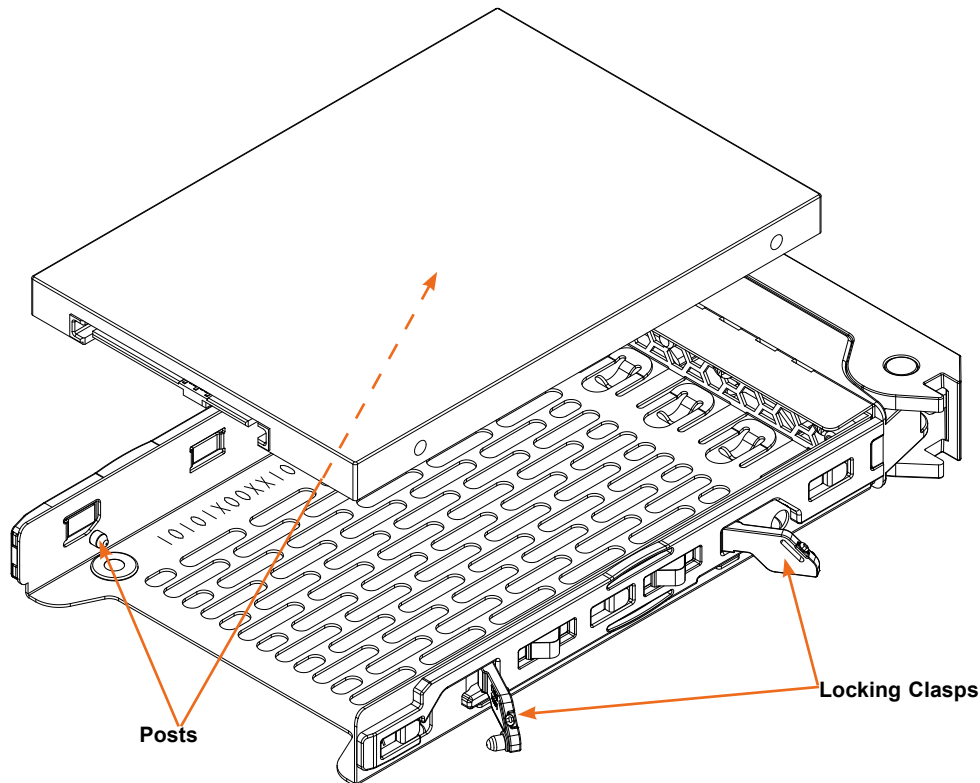

**Figure 3-9. Installing a Drive into a Carrier**

3. Tilt the drive to insert it onto the two posts inside of the carrier.
4. Pull out the two spring locking clasps and allow the drive to sit fully in the carrier, then close them to secure the drive.
5. Insert the drive carrier into its bay, keeping the release button on the bottom. When the carrier reaches the rear of the bay, the release handle will retract.
6. Push the handle in until it clicks into its locked position

### M.2 Drives

The system supports two M.2 NVMe SSDs. They are located underneath the switch module, and should be installed or replaced by the manufacturer.

## Checking the Temperature of an NVMe Drive

There are two ways to check using the BMC Dashboard.

### *Checking a Drive*

- **BMC Dashboard > Server Health > NVMe SSD** – Shows the temperatures of all NVMe drives.
- **BMC Dashboard > Server Health > Sensor Reading > NVME\_SSD** – Shows the single highest temperature among all the NVMe drives.

## 3.6 System Cooling

Multiple 8-cm fans provide the cooling for the system. Fans may be replaced while the system continues to operate. Cooling is aided by louvers in the chassis that help prevent expelled hot air from returning into the chassis.

### Changing a System Fan

To replace fans in the chassis front, or on the top row of the chassis rear. The logical fan numbering is shown in Chapter 1.

1. Determine which fan is failing. If possible, use the BMC.
2. Pinch the metal release latches on each side of the fan, and pull the fan out.
3. Place the replacement fan into the vacant space. Push until the latches click and the fan is secure.

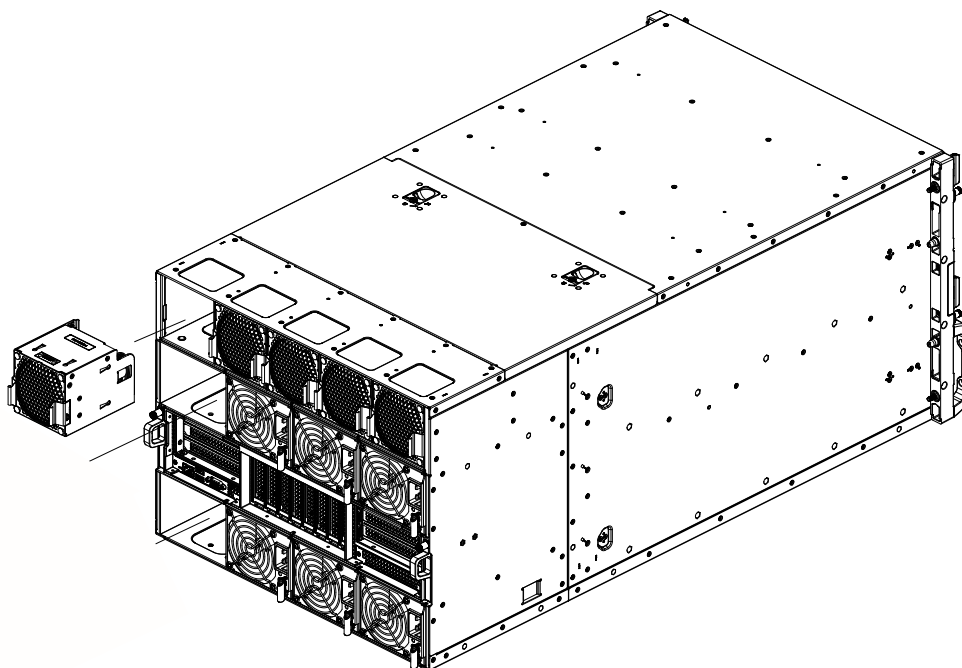

**Figure 3-10. Replacing the Fans**

To replace a power supply/fan combination, see the Power Supply section.

## Motherboard Air Shroud

The air shroud system concentrates airflow to maximize fan efficiency. It is installed on the motherboard tray around the CPU heatsinks, and above the DIMMs.

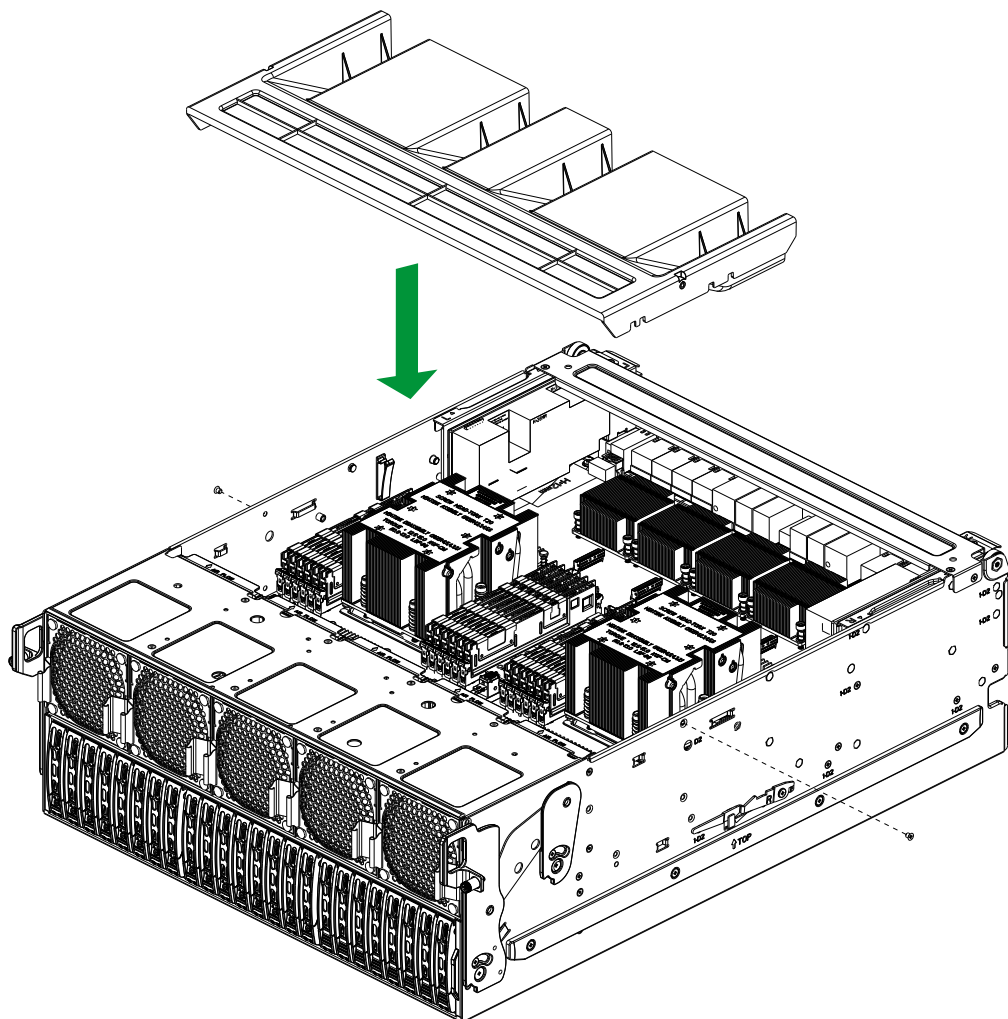

Figure 3-11. Installing the Motherboard Air Shroud

## GPU Air Blockers

Two metal GPU air blockers fit along the sides of the GPU tray to concentrate the airflow.

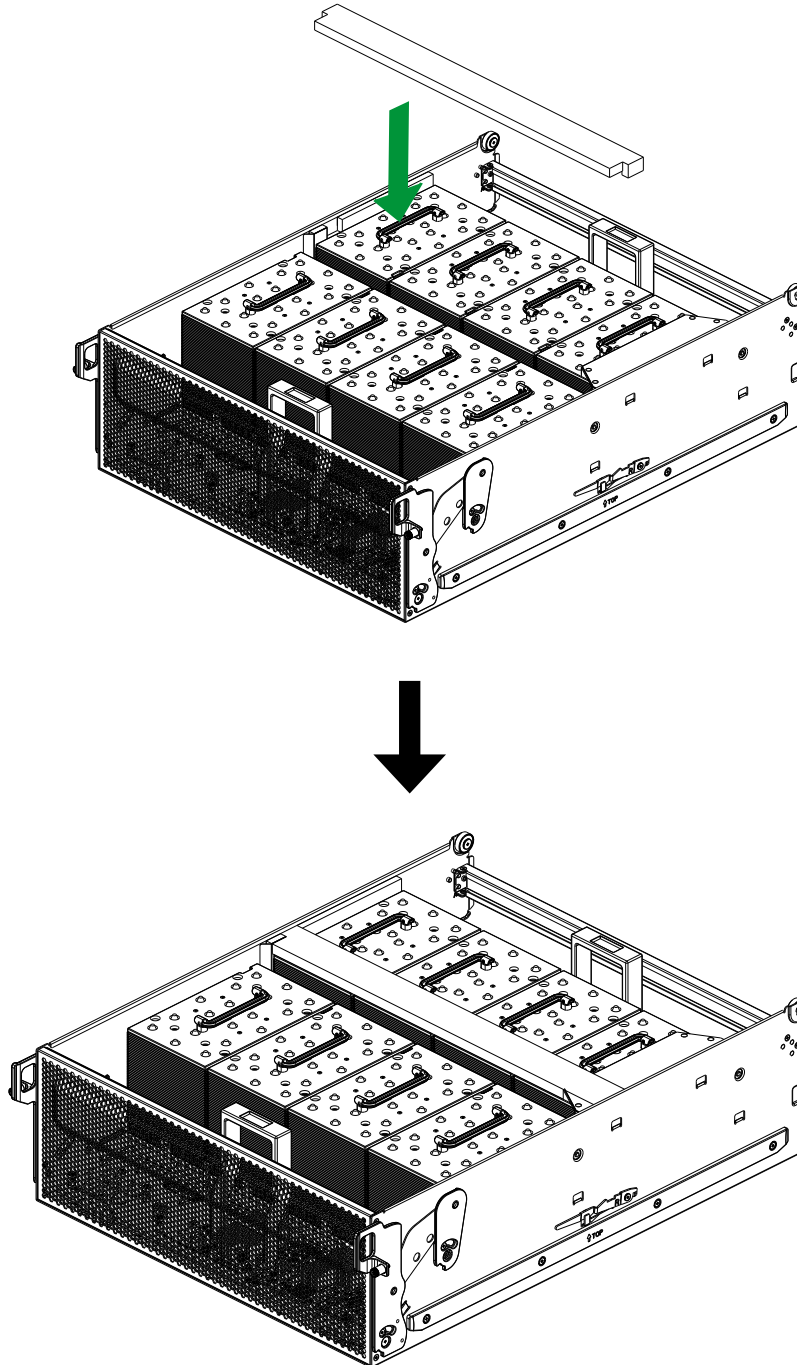

Figure 3-12. Installing the GPU Air Blockers

## 3.7 PCIe Expansion Cards

The default system can accommodate 12 PCIe cards. An optional kit can be added to support two more

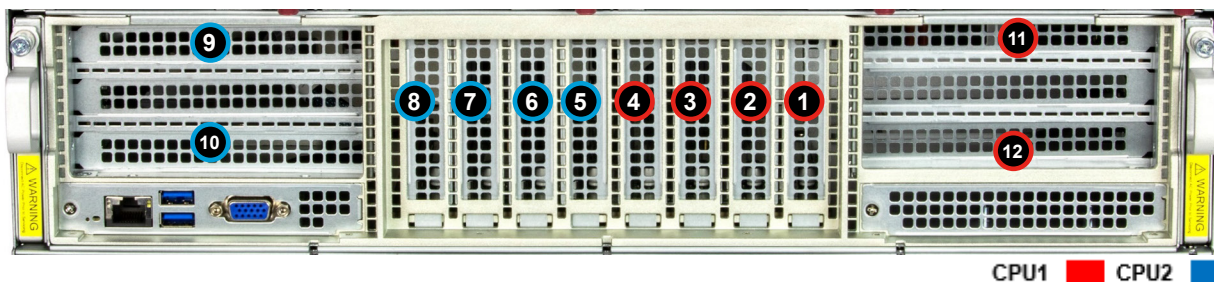
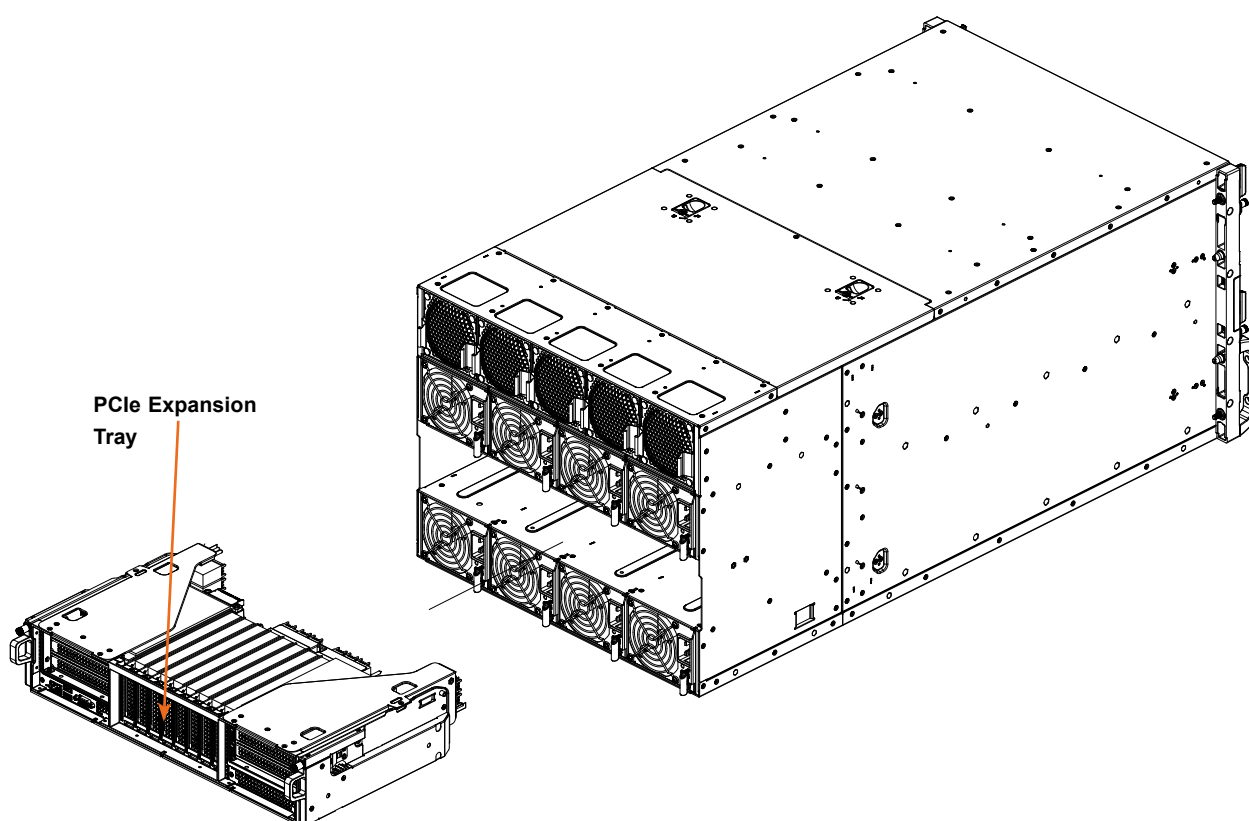

Figure 3-13. Expansion Cards

Expansion Slot Locations	
Slot	Description
1	PCIe 5.0 x16 (LP) from PLX switch to GPUs
2	PCIe 5.0 x16 (LP) from PLX switch to GPUs
3	PCIe 5.0 x16 (LP) from PLX switch to GPUs
4	PCIe 5.0 x16 (LP) from PLX switch to GPUs
5	PCIe 5.0 x16 (LP) from PLX switch to GPUs
6	PCIe 5.0 x16 (LP) from PLX switch to GPUs
7	PCIe 5.0 x16 (LP) from PLX switch to GPUs
8	PCIe 5.0 x16 (LP) from PLX switch to GPUs
9	PCIe 5.0 x16 (FHHL) (requires an optional NIC kit)
10	PCIe 5.0 x16 (FHHL) (requires an optional NIC kit)
11	PCIe 5.0 x16 (FHHL)
12	PCIe 5.0 x16 (FHHL)

### Installing Expansion Cards (1–8)

1. Power down the system and pull out the PCIe expansion tray as described in Section 3.2.
2. In the front of the tray, remove the blank PCI shield.
3. Slide the expansion card into the PCIe slot on the PCIe expansion tray floor while aligning the bracket with the chassis. It may be helpful to remove one of the riser card brackets to allow room to work (see next subsection).
4. Push the PCIe expansion tray into the chassis.



**Figure 3-14. Adding Expansion Card (1–8)**

**Caution:** Do not lift the chassis by the empty PCIe tray slot.

### Installing Riser Expansion Cards (9–12)

Expansion cards can be added for slots 9–12 by means of riser cards mounted on riser card brackets as shown below.

1. Power down the system and remove the PCIe tray as described in Section 3.2.
2. Unscrew (four screws for each) and remove the riser card bracket for the slots you want to use.

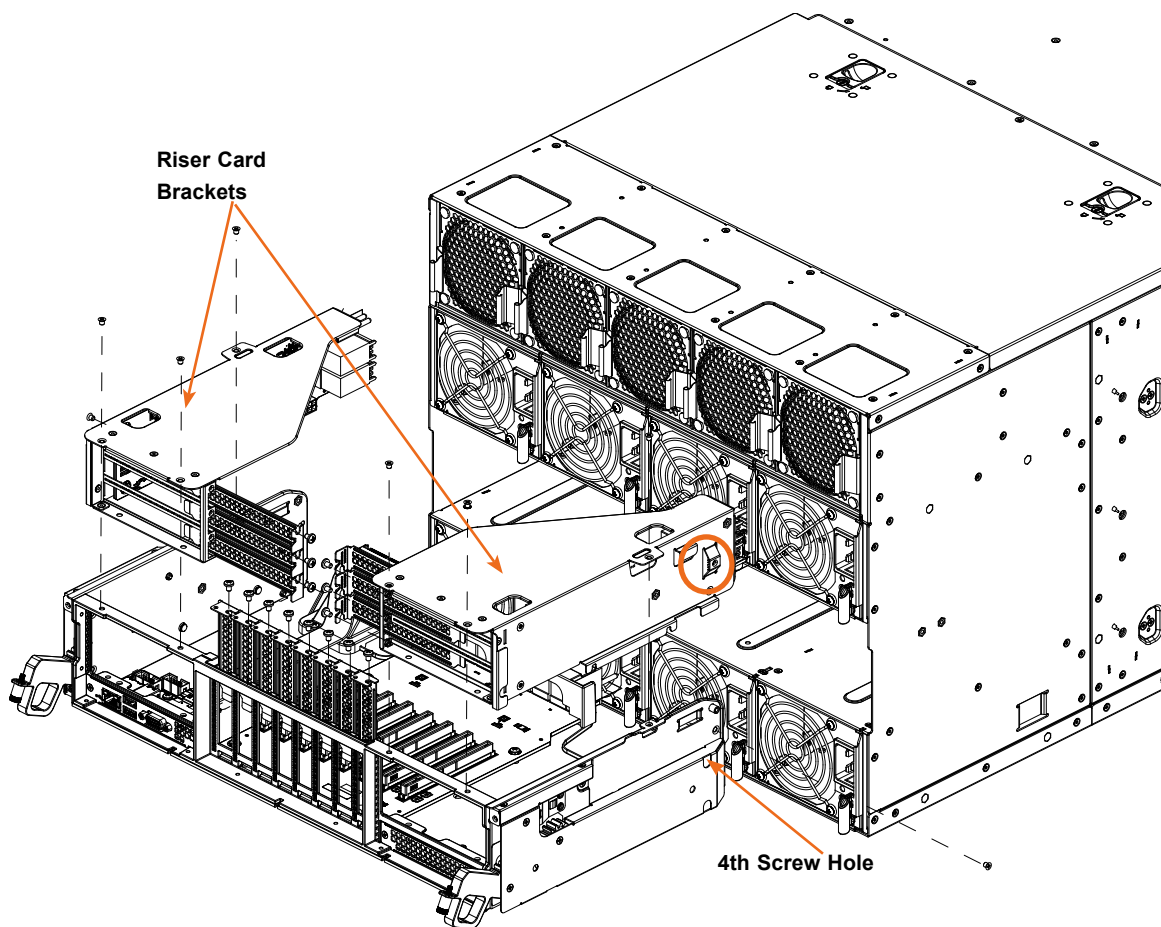
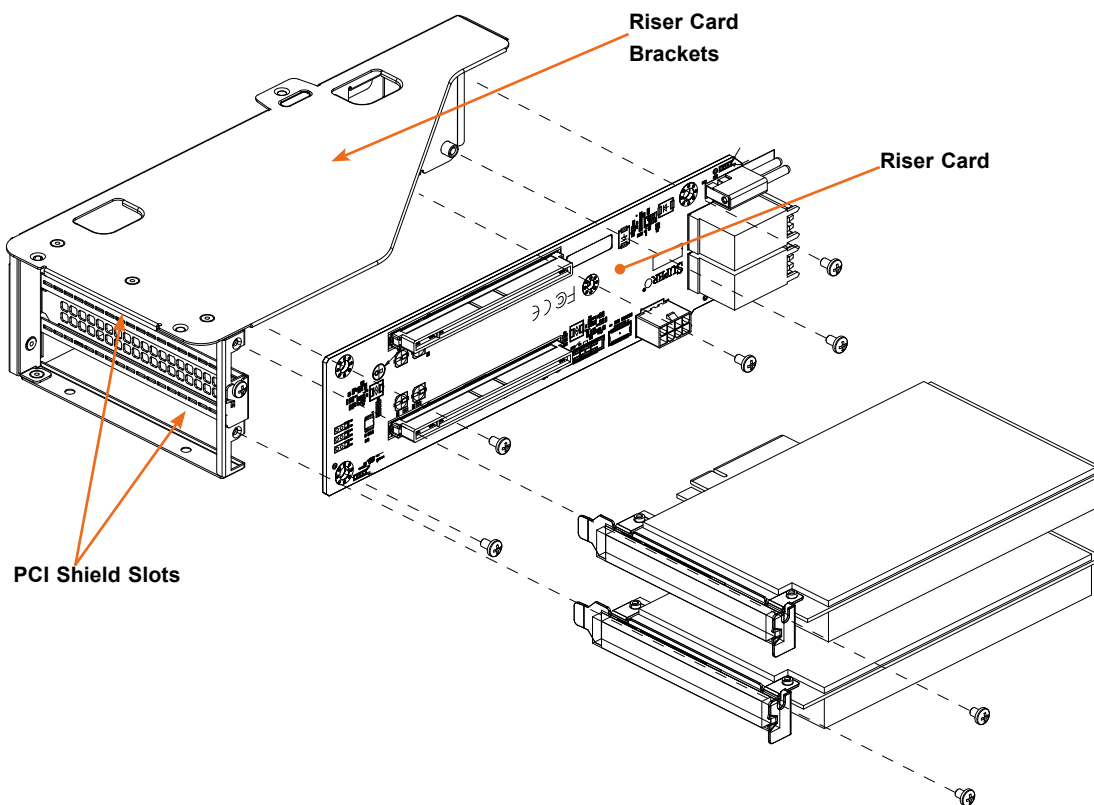

Figure 3-15. Removing Riser Card Brackets and Shields



**Figure 3-16. Riser Card Brackets and Shields**

3. Remove the blank PCI shield that covers the bracket slot.
4. Slide the expansion card(s) into the slot(s) on the riser card while aligning the shield(s) with the bracket.
5. Return the brackets to the PCIe tray and the PCIe tray into the chassis.

## 3.8 Power Supply

The system features redundant power supplies. The power modules can be changed without powering down the system, but only up to the redundancy supported. Standard configuration supports 4 + 2 redundancy. Up to two modules can be offline for service, although that is not recommended. New units can be ordered directly from Supermicro or authorized distributors.

### Power Supply LEDs

On the rear of the power supply module, there is an LED that displays the power status.

Power Supply Indicator	
LED Color and State	Power Supply Condition
Solid Green	Indicates that the power supply is on
Blinking Green	Indicates that the power supply is plugged in and turned off by the system.
Blinking Amber	Indicates that the power supply has a warning condition and continues to operate.
Solid Amber	Indicates that the power supply is plugged in, and is in an abnormal state. The system might need service. Please contact Supermicro technical support.
Off	No AC power to modules

### ***Replacing the Power Supply***

The logical power supply module numbering is shown in Chapter 1.

1. Unplug the AC cord from the module to be replaced.
2. Pull the release handle on the back of the power supply as illustrated.
3. Pull the power supply out using the handle.
4. Replace the failed power module with the same model.
5. Push the new power supply module into the power bay until it clicks.
6. Plug the AC power cord back into the module.

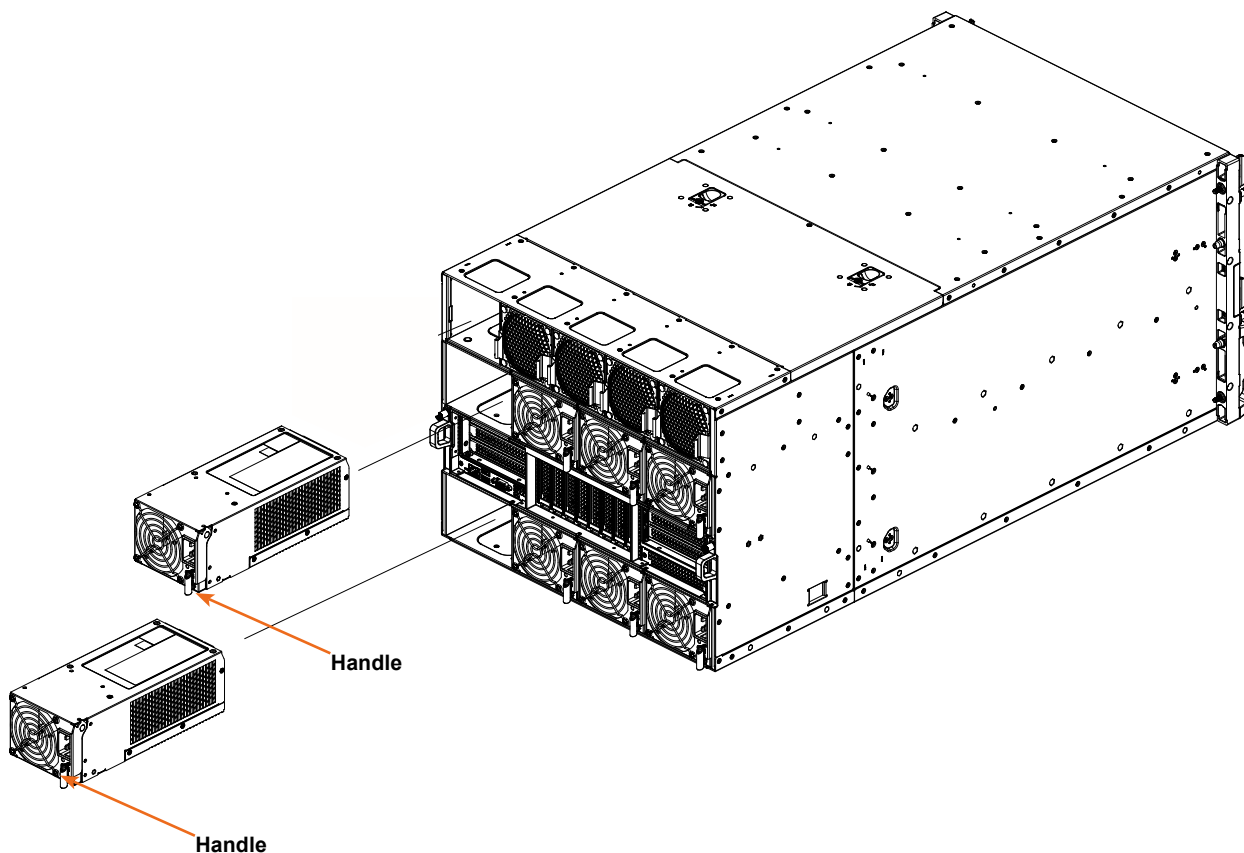

**Figure 3-17. Installing a Power Supply Module**

**Caution:** Do not attempt to lift the chassis by the empty power supply slot.

# Chapter 4

## Motherboard Connections

This section describes the connections on the motherboard and provides pinout definitions. Note that depending on how the system is configured, not all connections are required. The LEDs on the motherboard are also described here. A motherboard layout indicating component locations may be found in Chapter 1.

Please review the Safety Precautions in Chapter 3 before installing or removing components.

### 4.1 Power Connections

#### Power Supply Connectors

This motherboard has four PowerMAX power input connectors. EJSW\_PWR1, EJSW\_PWR3, and EJSW\_PWR4 are used for 12 V DC power input via the midplane, while EJSW\_P54V is used for 54 V DC power input via the midplane.

#### Power Connector for NIC Card Carrier Board

EJSW\_PWR2 is a PowerMAX connector that provides 12 V DC power. It is designed to deliver power to the NIC card carrier board.

#### Power Connector for System Fan Board

P54V\_JPWR1 is an 8-pin 54 V DC power output connector. It is designed to deliver 54 V power to the fan board.

8-pin 54 V Power Pin Definitions	
Pin#	Definition
1-4	Ground
5-8	P54V (54V Power)

## Power Connectors

There are five 8-pin 12 V DC power connectors (JPWR1 – 5) on the motherboard to provide adequate power to the onboard devices. Refer to the table below for pin definitions.

8-pin 12 V Power Pin Definitions	
Pin#	Definition
1-4	Ground
5-8	+12 V

## Midplane and NIC Card Carrier Board Connectors

There are eight ExaMax connectors (EJSW\_3 – EJSW\_10) on the motherboard to connect to the midplane for the GPU system. EJSW\_GDE1 and EJSW\_GDE2 are the guide pins for the midplane.

In addition, there are six PCIe 5.0 ExaMax connectors (EJNIC1 – 6) to connect to the NIC card carrier board, which supports eight PCIe 5.0 x16 connections.

## 4.2 Headers and Connectors

### Fan Headers

There are four 6-pin fan headers (FAN1 – 4) on the motherboard. These fan headers are used for the cooling fans for your system. Fan speed control for these fans is supported by Thermal Management via the BMC 2.0 interface. Refer to the layout below for the locations of the fan headers.

6-pin Fan Header Pin Definitions	
Pin#	Definition
1	Ground
2	3 A/+12 V
3	Tachometer
4	PWM_Control
5	3 A/12 V
6	Ground

### TPM / Port 80 Connector

The JTPM1 header is used to connect a TPM Module for Trust Platform Module/Port 80 support. The TPM module, which is optional and available from Supermicro, is a security device that supports encryption and authentication in hard drives. It allows the motherboard to deny access if the TPM associated with the hard drive is not installed in the system.

See the layout below for the location of the TPM header. Please go to the following link for more information on the TPM: [https://www.supermicro.com/manuals/other/AOM-TPM-9670V\\_9670H.pdf](https://www.supermicro.com/manuals/other/AOM-TPM-9670V_9670H.pdf).

Trusted Platform Module Header Pin Definitions			
Pin#	Definition	Pin#	Definition
1	+3.3 V	2	SPI_CS#
3	RESET#	4	SPI_MISO
5	SPI_CLK	6	GND
7	SPI_MOSI	8	NC
9	+3.3 V Stdby	10	SPI_IRQ#

### VROC RAID Key Header

A VROC RAID Key header is located at JRK1 on the motherboard. Install a VROC RAID Key on JRK1 for NVMe RAID support as shown in the illustration below. Refer to the layout below for the location of JRK1.

**Note:** For detailed instructions on how to configure VROC RAID settings, please refer to the VROC RAID Configuration User's Guide posted on the web page under the link:

<https://www.supermicro.com/support/manuals/>.

Intel VROC Key Pin Definitions	
Pin#	Definition
1	Ground
2	3.3 V Standby
3	Ground
4	PCH RAID Key

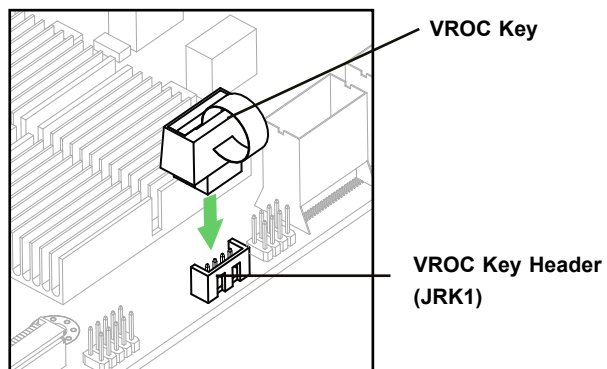

**Note:** The graphics contained in this user's manual are for illustration purposes only. The components installed in your system may or may not look exactly the same as the graphics shown in the manual.

### 4-pin BMC External I<sup>2</sup>C Header

A System Management Bus header for the BMC is located at JIPMB1. Connect the appropriate cable here to use the IPMB I<sup>2</sup>C connection on your system. Refer to the layout for the location of JIPMB1.

### NC-SI Connector

The NC-SI (Network Controller Sideband Interface) connector is located at (JNCSI1). This connector is used to connect a Network Interface Card (NIC) to the motherboard to allow the onboard BMC (Baseboard Controller) to communicate with a network.

**Note:** For detailed instructions on how to configure Network Interface Card (NIC) settings, please refer to the Network Interface Card Configuration User's Guide posted at: <https://www.supermicro.com/support/manuals/>.

### Side Switch Board I<sup>2</sup>C Headers

Two I<sup>2</sup>C headers for side switch boards are located at JSSW1 and JSSW2 on the motherboard. Connect the appropriate cables here to use the I<sup>2</sup>C connections for the side switch boards on your system. See the table below for pin definitions.

Side Switch Board I <sup>2</sup> C Header Pin Definitions	
Pin#	Definition
1	P3V3_STBY
2	Clock
3	Data
4	Ground
5	Ground
6	P3V3_STBY

### Fan Board I<sup>2</sup>C Header

An I<sup>2</sup>C fan header for the fan board is located at EJ21. Fan speed control for this fan is supported by Thermal Management via the BMC 2.0 interface. See the table below for pin definitions.

Side Switch Board I <sup>2</sup> C Header Pin Definitions	
Pin#	Definition
1	Data
2	Ground
3	Clock
4	P3V3_STBY

### VPP I<sup>2</sup>C Header

A VPP I<sup>2</sup>C header for storage backplane is located at JNVVPP1 on the motherboard. Connect the appropriate cable here to use the VPP I<sup>2</sup>C connection on your system. See the table below for pin definitions.

VPP I <sup>2</sup> C Header Pin Definitions	
Pin#	Definition
1	Data
2	Ground
3	Clock
4	P3V3

### NVMe I<sup>2</sup>C Header

The NVMe SMBus (I<sup>2</sup>C) header (JNVI2C1) provides hot-plug support via a dedicated SMBus interface. This feature is only available for a Supermicro complete system with an Supermicro proprietary NVMe add-on card and a proper cable installed. See the table below for pin definitions.

NVMe I <sup>2</sup> C Header Pin Definitions	
Pin#	Definition
1	Data
2	Ground
3	Clock
4	P3V3

### Liquid Cooling Leak Detection Connector

Two liquid cooling leak detection connectors are located at JLC1 and JLC2 on the motherboard. JLC1 is used for leak detection on the CPU side, while JLC2 is used for leak detection on the GPU side. Attach the appropriate cable from the chassis to inform you when the leak is detected. Refer to the table below for pin definitions.

Leak Detection Connector Pin Definitions	
Pin#	Definition
1	Ground
2	P12V
3	Detection Pin

**PCIe 3.0 NVMe M.2 Slots**

Two PCIe 3.0 x2 NVMe M.2 slots supported by Intel PCH are located at JM2\_D on the motherboard. These M.2 slots support M.2 NVMe SSDs in the 2280 and 22110 form factors. M.2 allows for a variety of card sizes, increased functionality, and spatial efficiency. Refer to the layout below for the locations of the M.2 slots.

**MCIO NVMe Connectors**

The motherboard has four MCIO x8 connectors (EJNVME1 – 4) supported by the PLX switches. Each of these connectors supports two PCIe 5.0 x4 NVMe connections.

**Note:** When connecting an NVMe device to the motherboard, please be sure to connect the first NVMe port (EJNVME1) first for your system to work properly.

In addition, there are four MCIO x8 connectors supported by the CPUs. JMCIO1A and JMCIO1B are supported by CPU1 while JMCIO2A and JMCIO2B are supported by CPU2. These MCIO connectors are used to connect to side switch boards for expansions.

**Slim SAS Connectors (for SATA 3.0 Connection)**

Two slim SAS x4 connectors are located at JS1 and JS2 on the motherboard. Each slim SAS connector supports four SATA 3.0 connections (JS1 for SATA0 – 4 and JS2 for SATA0 – 7). These slim SAS connectors are supported by the Intel C741 chipset. Connect proper cables to JS1/JS2 to use SATA 3.0 connections.

## 4.3 Input/Output Ports

### I/O Module Connectors

There are two connectors on the motherboard that can be used for I/O modules connections. An ExaMAX connector, located at JSW1, supports the rear I/O module connection via the midplane. Another connector, located at JFP2, provides connection to an I/O module for front access. Both connectors support the following components on the I/O module:

- Two USB 3.0 ports
- One VGA port
- One BMC dedicated LAN port
- One UID switch
- One UID LED indicator

**Note:** JSW1 and JFP2 connectors are mutually exclusive; only one connector can be utilized at a time.

## 4.4 Jumpers

### How Jumpers Work

To modify the operation of the motherboard, jumpers can be used to choose between optional settings. Jumpers create shorts between two pins to change the function of the connector. Pin #1 is identified with a square solder pad on the printed circuit board. See the diagram below for an example of jumping pins 1 and 2. Refer to the motherboard layout page for jumper locations.

**Note 1:** On two-pin jumpers, "Closed" means the jumper is on and "Open" means the jumper is off the pins.

**Note 2:** Unplug the power cord from all power supplies before adjusting jumper settings.

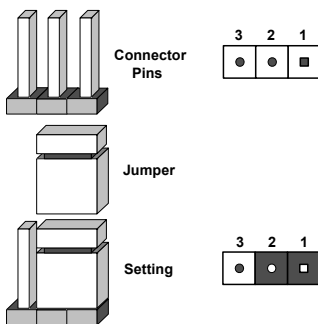

### CMOS Clear

JBT1 is used to clear CMOS, which will also clear any passwords. Instead of pins, this jumper consists of contact pads to prevent accidentally clearing the contents of CMOS.

#### To Clear CMOS

1. First power down the system and unplug the power cord(s).
2. Remove the cover of the chassis to access the motherboard and remove the battery from the motherboard.
3. Short the CMOS pads, JBT1, with a metal object such as a small screwdriver for at least four seconds.
4. Remove the screwdriver (or shorting device).
5. Replace the cover, reconnect the power cord(s), and power on the system.

**Note :** Clearing CMOS will also clear all passwords.

## 4.5 LED Indicators

### Onboard Power LED

The Onboard Power LED is located at LEDPWR on the motherboard. When this LED is on, the system power is on. Be sure to turn off the system power and unplug the power cords before removing or installing components. Refer to the table below for more information.

Onboard Power LED Indicator	
LED Color	Definition
Off	System Power Off (power cable not connected)
Green	System Power On

### BMC Heartbeat LED

A BMC Heartbeat LED is located at LEDBMC on the motherboard. When LEDBMC is blinking green, the BMC is functioning normally. Refer to the layout below for the location of LEDBMC.

BMC Heartbeat LED State	
LED Color	Definition
Green: Blinking	BMC Normal

### M.2 LED Indicators

Two M.2 LED indicators are located at LED4 and LED7 on the motherboard. When LED4 is blinking, the bottom M.2 device functions normally. When LED7 is blinking, the top M.2 device functions properly. Refer to the layout below for locations of LED4 and LED7.

M.2 LED State	
LED Color	Definition
Green: Blinking	M.2 device working

## 4.6 M.2 Solid State Drive Installation

### Installing Dual M.2 SSDs

1. Disconnect power from the motherboard or system.
2. Refer to the motherboard layout and locate the M.2 dual slot (J18).
3. Insert lower M.2 sideways into the connector so that it lays flat, then follow the instructions below from ① to ③.
4. Insert upper M.2 sideways into the connector so that it lays flat, then follow the instructions below from ④ to ⑥.

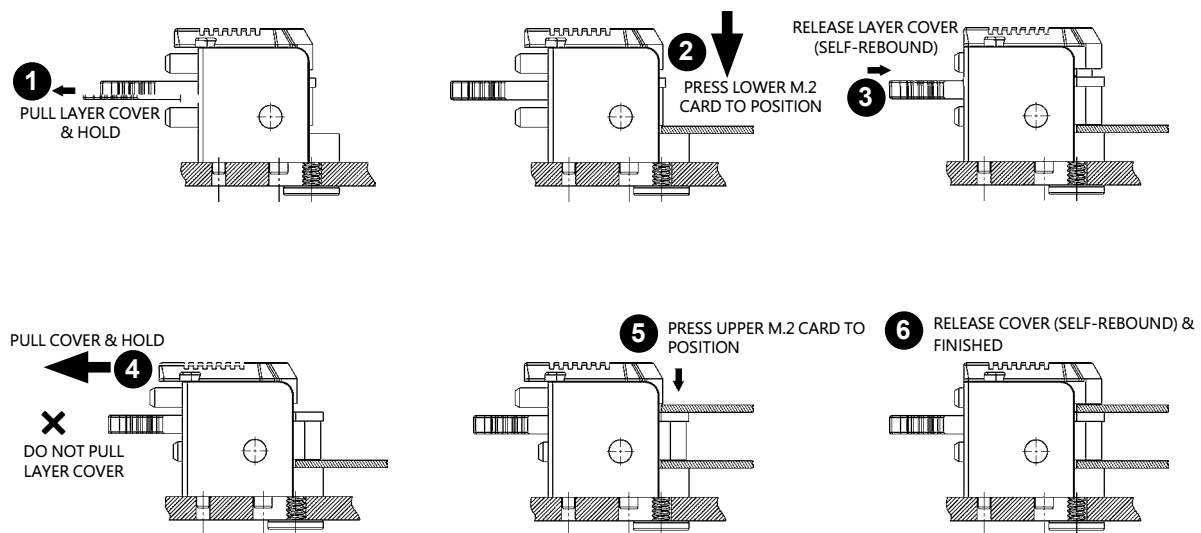

### Releasing Dual M.2 SSDs

1. Follow the instructions below from ① to ⑤ to remove M.2 SSDs.

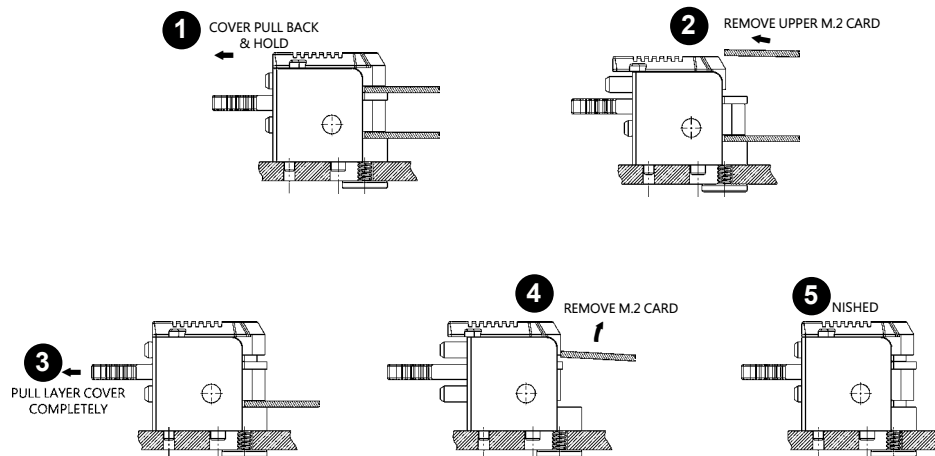

Figure 4-1. Releasing Dual M.2 SSDs

# Chapter 5

## Software

After the hardware has been installed, you can install the Operating System (OS), configure RAID settings, and install the drivers.

### 5.1 Microsoft Windows OS Installation

If you will be using RAID, you must configure RAID settings before installing the Windows OS and the RAID driver. Refer to the RAID Configuration User Guides posted on our website at [www.supernmicro.com/support/manuals](http://www.supernmicro.com/support/manuals).

#### *Installing the OS*

1. Create a method to access the Microsoft Windows installation ISO file. That can be a USB flash or media drive.
2. Retrieve the proper RST/RSTe driver. Go to the Supermicro web page for your motherboard and click on "Download the Latest Drivers and Utilities", select the proper driver, and copy it to a USB flash drive.
3. Boot from a bootable device with Windows OS installation. You can see a bootable device list by pressing **<F11>** during the system startup.

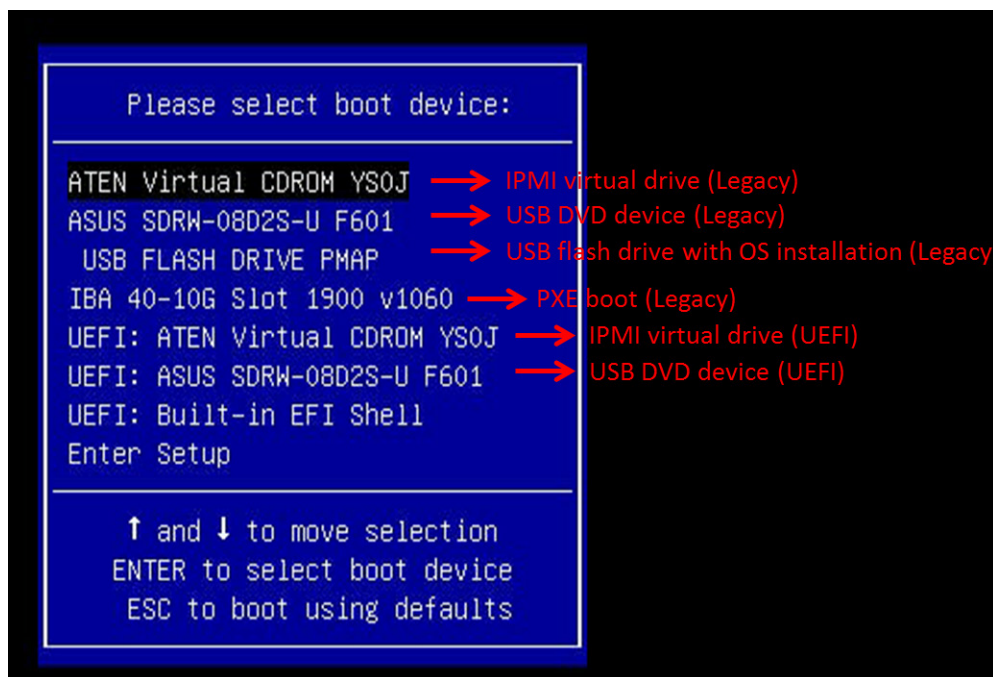
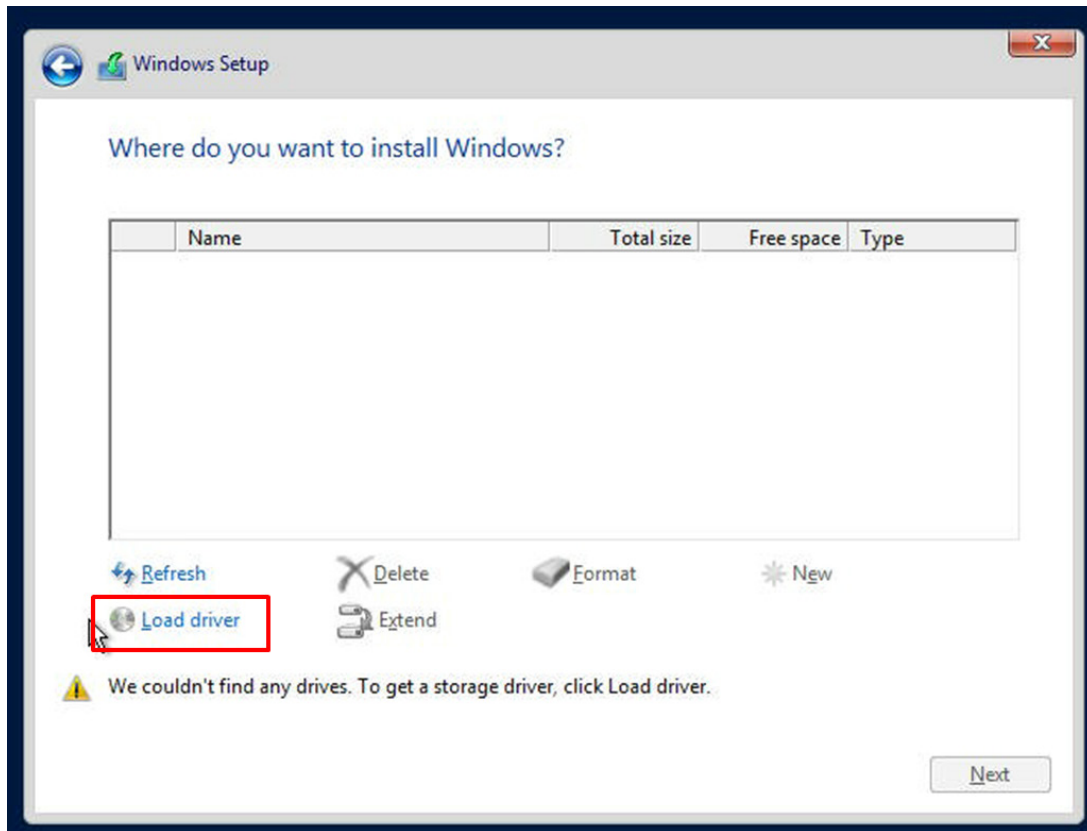

Figure 5-1. Select Boot Device

4. During Windows Setup, continue to the dialog where you select the drives on which to install Windows. If the disk you want to use is not listed, click on “Load driver” link at the bottom left corner.



**Figure 5-2. Load Driver Link**

To load the driver, browse the USB flash drive for the proper driver files.

- For RAID, choose the SATA/sSATA RAID driver indicated then choose the storage drive on which you want to install it.
  - For non-RAID, choose the SATA/sSATA AHCI driver indicated then choose the storage drive on which you want to install it.
5. Once all devices are specified, continue with the installation.
  6. After the Windows OS installation has completed, the system will automatically reboot multiple times.

## 5.2 Driver Installation

The Supermicro website contains drivers and utilities for your system at <https://www.supermicro.com/wdl/>. Some of these must be installed, such as the chipset driver.

After accessing the website, go into the CDR\_Images (in the parent directory of the above link) and locate the ISO file for your motherboard. Download this file to a USB flash or media drive. (You may also use a utility to extract the ISO file if preferred.)

Another option is to go to the Supermicro website at <http://www.supermicro.com/products/>. Find the product page for your motherboard, and "Download the Latest Drivers and Utilities".

Insert the flash drive or disk and the screenshot shown below should appear.

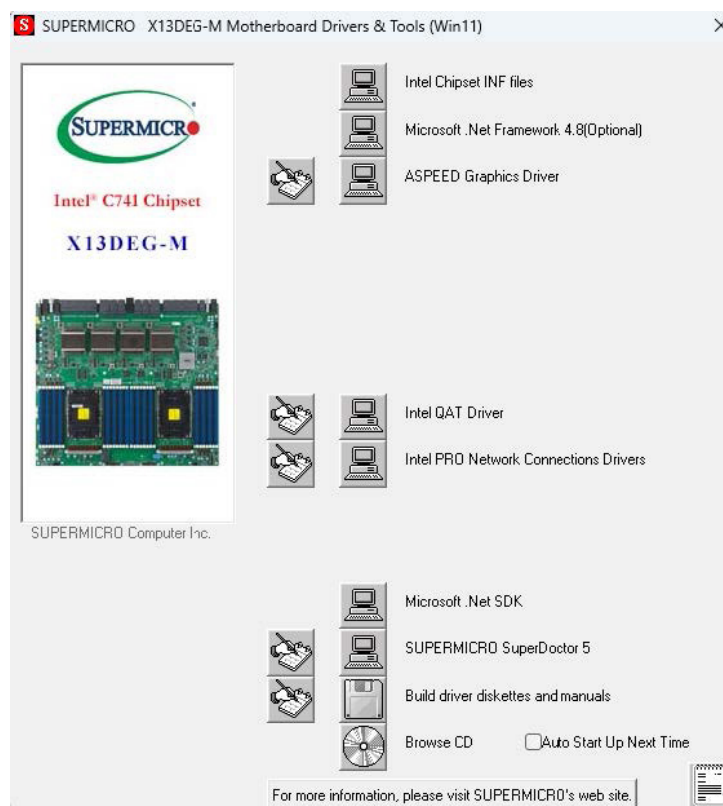

**Figure 5-3. Driver & Tool Installation Screen**

**Note:** Click the icons showing a hand writing on paper to view the readme files for each item. Click the computer icons to the right of these items to install each item (from top to the bottom) one at a time. **After installing each item, you must re-boot the system before moving on to the next item on the list.** The bottom icon with a CD on it allows you to view the entire contents.

## 5.3 BMC

The X13DEG-M motherboard provides remote access, monitoring and management through the baseboard management controller (BMC) and other management controllers distributed among different system modules. There are several BIOS settings that are related to BMC. For general documentation and information on BMC, visit our website at:

<https://www.supermicro.com/products/nfo/BMC.cfm>.

## 5.4 Logging into the BMC

Supermicro ships standard products with a unique password for the BMC ADMIN user. This password can be found on a label on the motherboard.

When logging in to the BMC for the first time, please use the unique password provided by Supermicro to log in. After logging in, you can change the administrator password to protect your security. When logging in as an administrator, you can also create a user account and set the password of your choice for subsequent logins.

*For more information regarding BMC passwords, please visit our website at*

<https://www.supermicro.com/bmcpassword>.

## Chapter 6

# Optional Components

This chapter describes optional system components and installation procedures.

### 6.1 Power Supply Modules

The default configuration includes six power supply modules. Two more can be added.

### 6.2 NIC Kit

The default configuration includes one expansion card kit (NIC Kit), which is composed of one internal side expansion card, one rear PCIe NIC riser, and supporting cables. This enables NVMe drive bays 0-11 and expansion slots 1-8 and 11-12.

A second NIC Kit is required to enable NVMe drive bays 12-15 and expansion slots 9-10.

### 6.3 Additional Storage Drives

An optional configuration offers 24 hot-swap storage drives. Requirements are listed below.



Figure 6-1. Front View, 24 Drives

Logical Storage Drive Numbers	
Item	Description
0 to 15	Sixteen 2.5-inch hot-swap NVMe drive bays
16 to 23	Eight 2.5-inch hot-swap SATA drive bays

A second NIC Kit as described in the previous section is a required part for this option.

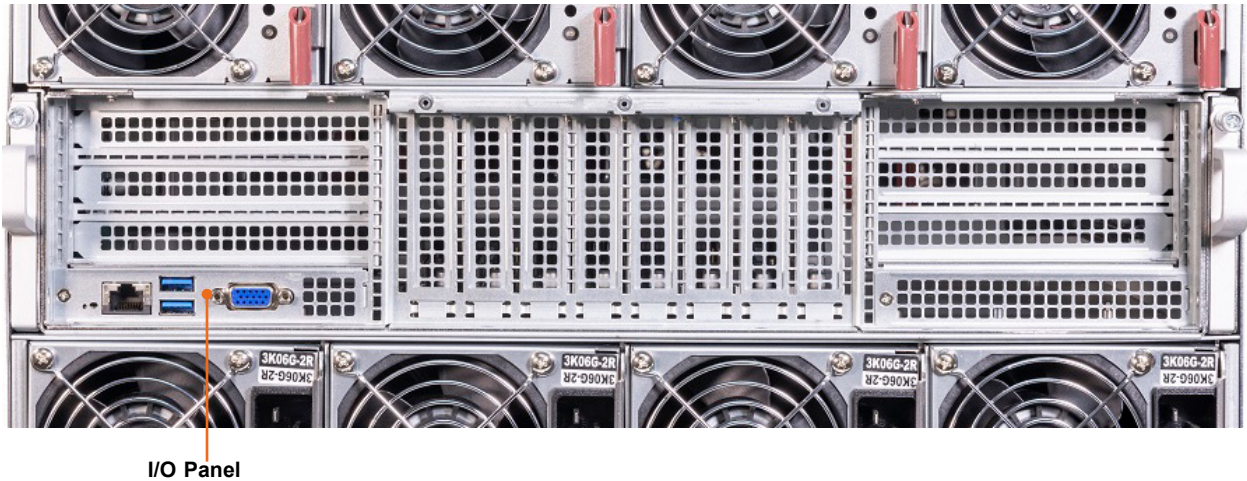

Figure 6-2. Rear View, with I/O Panel

# Chapter 7

## Troubleshooting and Support

### 7.1 Information Resources

#### Website

A great deal of information is available on the Supermicro website, [supermicro.com](http://supermicro.com).

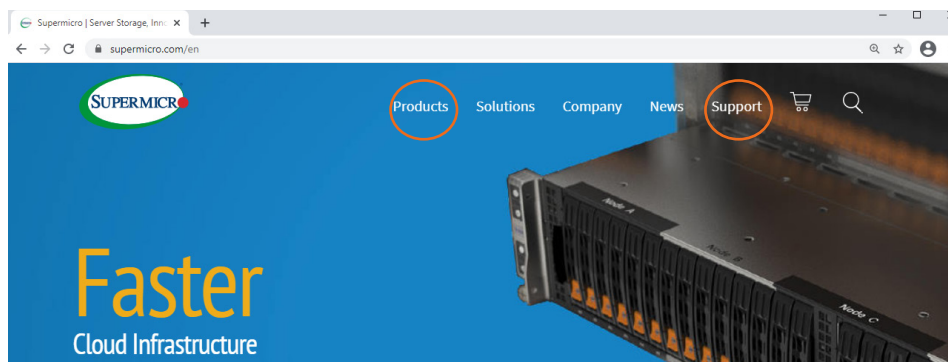

Figure 7-1. Supermicro Website

- Specifications for servers and other hardware are available by clicking the Products option.
- The Support option offers downloads (manuals, BIOS/BMC, drivers, etc.), FAQs, RMA, warranty, and other service extensions.

#### ***Direct Links for the SYS-821GE-TNMR2 System***

Web SYS-821GE-TNMR2 [specifications page](#)

Web X13DEG-M [motherboard page](#) for links to the Quick Reference Guide, User Manual, validated storage drives, etc.

#### ***Direct Links for General Support and Information***

[Frequently Asked Questions](#)

[Add-on card descriptions](#)

[TPM User Guide](#)

[BMC User Guide](#)

## Direct Links (continued)

### [SuperDoctor5 Large Deployment Guide](#)

For validated memory, use our [Product Resources page](#)

[Product Matrices](#) page for links to tables summarizing specs for systems, motherboards, power supplies, riser cards, add-on cards, etc.

[Security Center](#) for recent security notices

[Supermicro Phone and Addresses](#)

## 7.2 BMC Interface

The system supports a Baseboard Management Controller (BMC) interface. It provides remote access, monitoring and management. There are several BIOS settings related to the BMC.

For general documentation and information on the BMC, please visit our website at: [https://www.supermicro.com/manuals/other/BMC\\_IPMI\\_X13\\_H13.pdf](https://www.supermicro.com/manuals/other/BMC_IPMI_X13_H13.pdf).

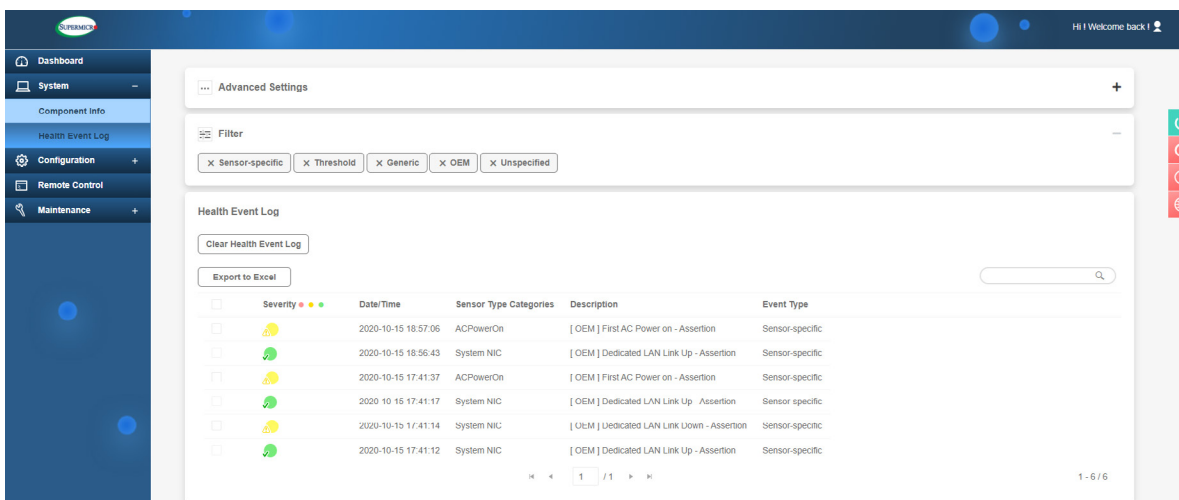

Figure 7-2. BMC Dashboard Sample

## 7.3 Troubleshooting Procedures

Use the following procedures to troubleshoot your system. If you have followed all of the procedures below and still need assistance, refer to the [Technical Support Procedures](#) or [Returning Merchandise for Service](#) sections in this chapter. Always disconnect the AC power cord before adding, changing, or installing any non hot-swap hardware components.

### Before Power On

1. Make sure that there are no short circuits between the motherboard and chassis.
2. Disconnect all ribbon/wire cables from the motherboard, including those for the keyboard and mouse.
3. Remove all add-on cards.
4. Install the CPU (making sure it is fully seated) and connect the front panel connectors to the motherboard.

### No Power

1. Check that the power LED on the motherboard is on.

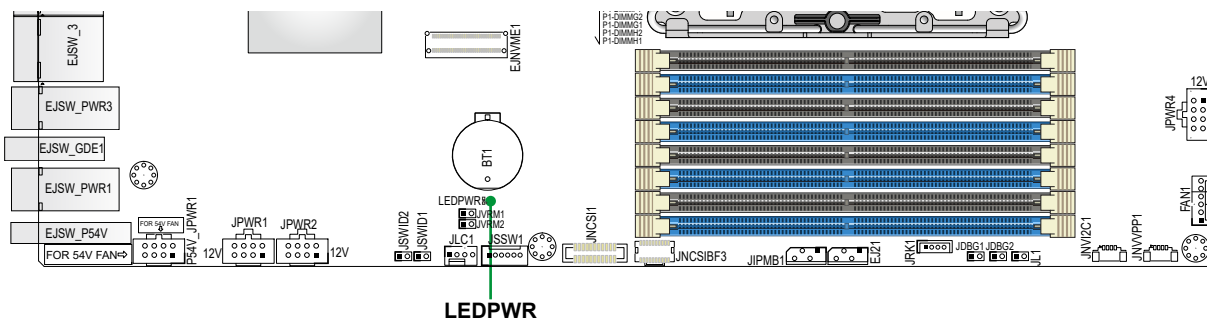

**Figure 7-3. Location of the MB Power LED**

2. Make sure that there are no short circuits between the motherboard and the chassis.
3. Make sure that the power supply connectors are properly connected.
4. Check that the 115 V/230 V switch, if available, on the power supply is properly set.
5. Turn the power switch on and off to test the system, if applicable.
6. The battery on your motherboard may be old. Check to verify that it still supplies approximately 3 VDC. If it does not, replace it with a new one.

## No Video

1. If the power is on, but you do not have video, remove all add-on cards and cables.
2. Remove all memory modules and turn on the system (if the alarm is on, check the specs of memory modules, reset the memory, or try a different one).

## System Boot Failure

If the system does not display Power-On-Self-Test (POST) or does not respond after the power is turned on, try the following:

1. Remove all components from the motherboard, especially the DIMM modules. Power on the system and check if the power-on LED (LEDPWR) and the BMC Heartbeat LED (LEDBMC) are on, and system fans are spinning.
2. Turn on the system with only one DIMM module installed. If the system boots, check for bad DIMM modules or slots by following the Memory Errors Troubleshooting procedure in this chapter.

## Memory Errors

1. Make sure that the memory modules are compatible with the system and are properly installed. See [Chapter 3](#) for installation instructions. (For memory compatibility, refer to the "Tested Memory List" link on the motherboard's product page to see a list of supported memory.)
2. Check if different speeds of DIMMs have been installed. It is strongly recommended that you use the same RAM type and speed for all DIMM modules in the system.
3. Make sure that you are using the correct type of ECC DDR5 modules recommended by the manufacturer.
4. Check for bad DIMM modules or slots by swapping a single module among all memory slots and check the results.

## Losing the System Setup Configuration

1. Make sure that you are using a high-quality power supply. A poor-quality power supply may cause the system to lose the CMOS setup information. Refer to [Chapter 1](#) for details on recommended power supplies.
2. The battery on your motherboard may be old. Check to verify that it still supplies approximately 3 VDC. If it does not, replace it with a new one.

## When the System Becomes Unstable

### **A. If the system becomes unstable during or after OS installation, check the following:**

1. CPU/BIOS support: Make sure that your CPU is supported and that you have the latest BIOS installed in your system.
2. Memory support: Make sure that the memory modules are supported by testing the modules using memtest86 or a similar utility.

**Note:** Click on the "Tested Memory List" link on the motherboard's product page to see a list of supported memory.

3. Storage drives support: Make sure that all drives work properly. Replace if necessary.
4. System cooling: Check the system cooling to make sure that all heatsink fans and CPU/system fans, etc., work properly. Check the hardware monitoring settings in the BMC to make sure that the CPU and system temperatures are within the normal range. Also check the front panel Overheat LED and make sure that it is not on.
5. Adequate power supply: Make sure that the power supply provides adequate power to the system. Make sure that all power connectors are connected. Refer to the Supermicro website for the minimum power requirements.
6. Proper software support: Make sure that the correct drivers are used.

### **B. If the system becomes unstable before or during OS installation, check the following:**

1. Source of installation: Make sure that the devices used for installation are working properly, including boot devices such as USB flash or media drives
2. Cable connection: Check to make sure that all cables are connected and working properly.
3. Using the minimum configuration for troubleshooting: Remove all unnecessary components (starting with add-on cards first), and use the minimum configuration (but with the CPU and a memory module installed) to identify the trouble areas. Refer to the steps listed in Section A above for proper troubleshooting procedures.
4. Identify bad components by isolating them: If necessary, remove a component in question from the chassis, and test it in isolation to make sure that it works properly. Replace a bad component with a good one.
5. Check and change one component at a time of changing several items at the same time. This will help isolate and identify the problem.

6. To find out if a component is good, swap this component with a new one to see if the system will work properly. If so, then the old component is bad. You can also install the component in question in another system. If the new system works, the component is good and the old system has problems.

## Issues with NVMe Storage Devices

***The numbering of NVMe storage devices are not shown as sequential in the operating system.***

This only happens after an M.2 NVMe device is installed. In the example of a twelve-bay system, NVMe4 (from CPU1) is occupied and NVMe9 (from CPU2) is occupied, causing the numbering of the NVMe storage devices in the operating system to be different from that of the physical presence of drives.

Before two M.2 device two installed:

NVMe2	NVMe5	NVMe8	NVMe11
NVMe1	NVMe4	NVMe7	NVMe10
NVMe0	NVMe3	NVMe6	NVMe9

After two M.2 devices are installed:

NVMe2	NVMe6	NVMe10	NVMe13
NVMe1	NVMe5	NVMe8	NVMe12
NVMe0	NVMe3	NVMe7	NVMe11

Note that NVMe4 and NVMe9 are gone. Once an M.2 NVMe device is installed, the operation system recognizes the storage devices based on the PCIe training sequences. (The numbering sequence begins with CPU1-connected devices and then CPU2-connected devices.)

***An NVMe drive is successfully ejected via the BMC Web GUI, but it displays "Exception" in the log.***

This is perfectly fine at this stage and will not affect your normal use of the drives and the BMC Web GUI.

## 7.4 BIOS POST Codes

The AMI BIOS supplies additional checkpoint codes, which are documented online at <http://www.supermicro.com/support/manuals/> ("AMI BIOS POST Codes User's Guide").

For information on AMI updates, please refer to <https://www.ami.com/products/>.

## 7.5 Technical Support Procedures

Before contacting Technical Support, please take the following steps. Also, please note that as a motherboard manufacturer, Supermicro also sells motherboards through its channels, so it is best to first check with your distributor or reseller for troubleshooting services. They should know of any possible problems with the specific system configuration that was sold to you.

1. Please go through the Troubleshooting Procedures and Frequently Asked Questions (FAQ) sections in this chapter or see the FAQs on our website (<https://www.supermicro.com/FAQ/index.php>) before contacting Technical Support.
2. BIOS upgrades can be downloaded from our website ([https://www.supermicro.com/ResourceApps/BIOS\\_BMC\\_Intel.html](https://www.supermicro.com/ResourceApps/BIOS_BMC_Intel.html)).
3. If you still cannot resolve the problem, include the following information when contacting Supermicro for technical support:
  - Motherboard model and PCB revision number
  - BIOS release date/version (This can be seen on the initial display when your system first boots up.)
  - System configuration
4. An example of a Technical Support form is on our website at <https://www.supermicro.com/RmaForm/>.
5. Distributors: For immediate assistance, please have your account number ready when placing a call to our Technical Support department. We can be reached by email at [support@supermicro.com](mailto:support@supermicro.com).

## 7.6 Frequently Asked Questions

**Question: What type of memory does my motherboard support?**

**Answer:** This motherboard supports up to 8 TB 3DS RDIMM/RDIMM DDR5 (288-pin) ECC memory with speeds up to 4800 MT/s (1PDC) or 4400 MT/s (2DPC) in 32 DIMM slots. To enhance memory performance, do not mix memory modules of different speeds and sizes. Please follow all memory installation instructions given on [Section 3-4](#) in Chapter 3.

**Question: How do I update my BIOS?**

**Answer:** It is recommended that you do not upgrade your BIOS if you are not experiencing any problems with your system. Updated BIOS files are located on our website at [https://www.supermicro.com/ResourceApps/BIOS\\_BMC\\_Intel.html](https://www.supermicro.com/ResourceApps/BIOS_BMC_Intel.html). Please check our BIOS warning message and the information on how to update your BIOS on our website. Select your motherboard model and download the BIOS file to your computer. Also, check the current BIOS revision to make sure that it is newer than your BIOS before downloading.

**Note 1:** The SPI BIOS chip used on this motherboard cannot be removed. Send your motherboard back to our RMA Department at Supermicro for repair.

**Note 2:** For BIOS Update and Recovery instructions, please refer to the Firmware Update and Recovery Instructions for Supermicro's X13 Motherboards User's Guide posted at <https://www.supermicro.com/support/manuals/>.

**Question: I use surprise hotplug to plug and unplug NVMe drives into the SYS-821GE-TNMR2 system and the NVMe LED keeps flashing an amber light. I have Linux OS and the PLX FW is 4.15 - what's the problem?**

**Answer:** The system only supports orderly hotplug under Linux with PLX GCA4.15 FW. Don't use surprise hotplug. If you use surprise hotplug and the NVMe LED begins flashing amber, reboot the system and the LED will turn to blue.

## 7.7 Battery Removal and Installation

### Battery Removal

**To remove the onboard battery, follow the steps below:**

1. Power off your system and unplug your power cable.
2. Locate the onboard battery as shown below.
3. Using a tool such as a pen or a small screwdriver, push the battery lock outwards to unlock it. Once unlocked, the battery will pop out from the holder.
4. Remove the battery.

### Proper Battery Disposal

**Warning:** Please handle used batteries carefully. Do not damage the battery in any way; a damaged battery may release hazardous materials into the environment. Do not discard a used battery in the garbage or a public landfill. Please comply with the regulations set up by your local hazardous waste management agency to dispose of your used battery properly.

### Battery Installation

**To install an onboard battery, follow the steps below:**

1. Power off your system and unplug your power cable.
2. Locate the onboard battery as shown below
3. Identify the battery's polarity. The positive (+) side should be facing up.
4. Insert the battery into the battery holder and push it down until you hear a click to ensure that the battery is securely locked.

**Warning:** When replacing a battery, be sure to only replace it with the same type.

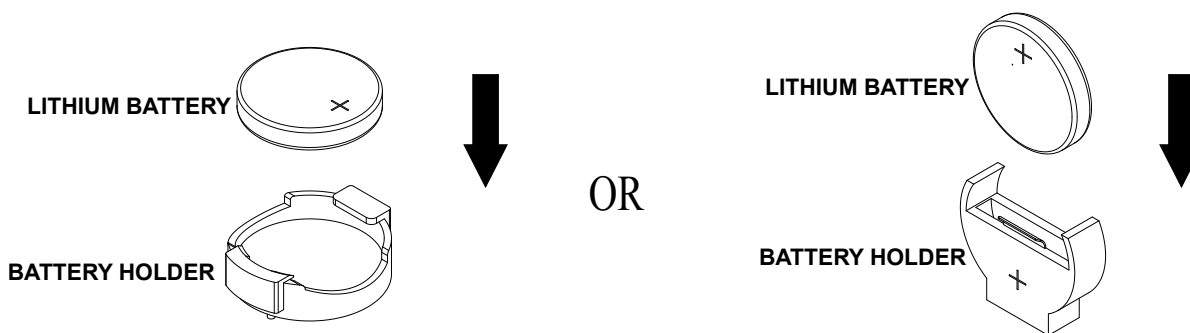

## 7.8 Where to Get Replacement Components

If you need replacement parts for your system, to ensure the highest level of professional service and technical support, purchase exclusively from our Supermicro Authorized Distributors/System Integrators/Resellers. A list can be found at: <http://www.supermicro.com>. Click the "Where to Buy" tab.

## 7.9 Reporting an Issue

### Returning Merchandise for Service

A receipt or copy of your invoice marked with the date of purchase is required before any warranty service will be rendered. You can obtain service by calling your vendor for a Returned Merchandise Authorization (RMA) number. When returning to the manufacturer, the RMA number should be prominently displayed on the outside of the shipping carton, and mailed prepaid or hand-carried. Shipping and handling charges will be applied for all orders that must be mailed when service is complete.

For faster service, RMA authorizations may be requested online (<http://www.supermicro.com/support/rma/>).

This warranty only covers normal consumer use and does not cover damages incurred in shipping or from failure due to the alteration, misuse, abuse or improper maintenance of products.

During the warranty period, contact your distributor first for any product problems.

## 7.10 Feedback

Supermicro values your feedback as we strive to improve our customer experience in all facets of our business. To provide feedback on our manuals, please email us at [techwriterteam@supermicro.com](mailto:techwriterteam@supermicro.com).

## 7.11 Contacting Supermicro

### Headquarters

Address: Super Micro Computer, Inc.  
980 Rock Ave.  
San Jose, CA 95131 U.S.A.

Tel: +1 (408) 503-8000

Fax: +1 (408) 503-8008

Email: [marketing@supermicro.com](mailto:marketing@supermicro.com) (General Information)  
[Sales-USA@supermicro.com](mailto:Sales-USA@supermicro.com) (Sales Inquiries)  
[Government\\_Sales-USA@supermicro.com](mailto:Government_Sales-USA@supermicro.com) (Gov. Sales Inquiries)  
[support@supermicro.com](mailto:support@supermicro.com) (Technical Support)  
[RMA@supermicro.com](mailto:RMA@supermicro.com) (RMA Support)  
[Webmaster@supermicro.com](mailto:Webmaster@supermicro.com) (Webmaster)

Website: [www.supermicro.com](http://www.supermicro.com)

### Europe

Address: Super Micro Computer B.V.  
Het Sterrenbeeld 28, 5215 ML  
's-Hertogenbosch, The Netherlands

Tel: +31 (0) 73-6400390

Fax: +31 (0) 73-6416525

Email: [Sales\\_Europe@supermicro.com](mailto:Sales_Europe@supermicro.com) (Sales Inquiries)  
[Support\\_Europe@supermicro.com](mailto:Support_Europe@supermicro.com) (Technical Support)  
[RMA\\_Europe@supermicro.com](mailto:RMA_Europe@supermicro.com) (RMA Support)

Website: [www.supermicro.nl](http://www.supermicro.nl)

### Asia-Pacific

Address: Super Micro Computer, Inc.  
3F, No. 150, Jian 1st Rd.  
Zhonghe Dist., New Taipei City 235  
Taiwan (R.O.C)

Tel: +886-(2) 8226-3990

Fax: +886-(2) 8226-3992

Email: [Sales-Asia@supermicro.com.tw](mailto:Sales-Asia@supermicro.com.tw) (Sales Inquiries)  
[Support@supermicro.com.tw](mailto:Support@supermicro.com.tw) (Technical Support)  
[RMA@supermicro.com.tw](mailto:RMA@supermicro.com.tw) (RMA Support)

Website: [www.supermicro.com.tw](http://www.supermicro.com.tw)

## Appendix A

# Standardized Warning Statements for AC Systems

## About Standardized Warning Statements

The following statements are industry standard warnings, provided to warn the user of situations which have the potential for bodily injury. Should you have questions or experience difficulty, contact Supermicro's Technical Support department for assistance. Only certified technicians should attempt to install or configure components.

Read this appendix in its entirety before installing or configuring components in the Supermicro chassis.

These warnings may also be found on our website at [http://www.supermicro.com/about/policies/safety\\_information.cfm](http://www.supermicro.com/about/policies/safety_information.cfm).

## Warning Definition



**Warning!** This warning symbol means danger. You are in a situation that could cause bodily injury. Before you work on any equipment, be aware of the hazards involved with electrical circuitry and be familiar with standard practices for preventing accidents.

### 警告の定義

この警告サインは危険を意味します。

人身事故につながる可能性がありますので、いずれの機器でも動作させる前に、電気回路に含まれる危険性に注意して、標準的な事故防止策に精通して下さい。

此警告符号代表危險。

您正处于可能受到严重伤害的工作环境中。在您使用设备开始工作之前，必须充分意识到触电的危险，并熟练掌握防止事故发生的标准工作程序。请根据每项警告结尾的声明号码找到此设备的安全性警告说明的翻译文本。

此警告符號代表危險。

您正處於可能身體可能會受損傷的工作環境中。在您使用任何設備之前，請注意觸電的危險，並且要熟悉預防事故發生的標準工作程序。請依照每一注意事項後的號碼找到相關的翻譯說明內容。

## Warnung

### WICHTIGE SICHERHEITSHINWEISE

Dieses Warnsymbol bedeutet Gefahr. Sie befinden sich in einer Situation, die zu Verletzungen führen kann. Machen Sie sich vor der Arbeit mit Geräten mit den Gefahren elektrischer Schaltungen und den üblichen Verfahren zur Vorbeugung vor Unfällen vertraut. Suchen Sie mit der am Ende jeder Warnung angegebenen Anweisungsnummer nach der jeweiligen Übersetzung in den übersetzten Sicherheitshinweisen, die zusammen mit diesem Gerät ausgeliefert wurden.

BEWAHREN SIE DIESE HINWEISE GUT AUF.

### INSTRUCCIONES IMPORTANTES DE SEGURIDAD

Este símbolo de aviso indica peligro. Existe riesgo para su integridad física. Antes de manipular cualquier equipo, considere los riesgos de la corriente eléctrica y familiarícese con los procedimientos estándar de prevención de accidentes. Al final de cada advertencia encontrará el número que le ayudará a encontrar el texto traducido en el apartado de traducciones que acompaña a este dispositivo.

GUARDE ESTAS INSTRUCCIONES.

### IMPORTANTES INFORMATIONS DE SÉCURITÉ

Ce symbole d'avertissement indique un danger. Vous vous trouvez dans une situation pouvant entraîner des blessures ou des dommages corporels. Avant de travailler sur un équipement, soyez conscient des dangers liés aux circuits électriques et familiarisez-vous avec les procédures couramment utilisées pour éviter les accidents. Pour prendre connaissance des traductions des avertissements figurant dans les consignes de sécurité traduites qui accompagnent cet appareil, référez-vous au numéro de l'instruction situé à la fin de chaque avertissement.

CONSERVEZ CES INFORMATIONS.

## תקנון הזהרות אזהרה

הזהרות הבאות הן אזהרות על פי תקני התעשייה, על מנת להזהיר את המשתמש מפני חבלה פיזית אפשרית. במידה ויש שאלות או היתקלות בבעיה כלשהי, יש ליצור קשר עם מחלקת תמיכה טכנית של סופרמיקרו. טכנאים מוסמכים בלבד רשאים להתקין או להגדיר את הרכיבים. יש לקרוא את הנספח במלואו לפני התקנת או הגדרת הרכיבים במארזי סופרמיקרו.

اَكْ ف حالة وُكِي اَي تتسبب ف اصابة جسدهُ هذا الزهز عُ خطر! تحذُرُ .  
 قبل اَي تعول على اَي هعدات، كي على علن بالوخاطز ال اُجوة عي الذوائر  
 الكهزبائِة  
 وكي على دراةُ بالووارسات النقااِة لو عُ وقع اَي حادث  
 استخدم رقن الب اِى الو صُص ف هاةُ كل تحذُرُ للعشر تزجوتها

안전을 위한 주의사항

경고!

이 경고 기호는 위험이 있음을 알려 줍니다. 작업자의 신체에 부상을 야기 할 수 있는 상태에 있게 됩니다. 모든 장비에 대한 작업을 수행하기 전에 전기회로와 관련된 위험요소들을 확인하시고 사전에 사고를 방지할 수 있도록 표준 작업절차를 준수해 주시기 바랍니다.

해당 번역문을 찾기 위해 각 경고의 마지막 부분에 제공된 경고문 번호를 참조하십시오

## BELANGRIJKE VEILIGHEIDSINSTRUCTIES

Dit waarschuwings symbool betekent gevaar. U verkeert in een situatie die lichamelijk letsel kan veroorzaken. Voordat u aan enige apparatuur gaat werken, dient u zich bewust te zijn van de bij een elektrische installatie betrokken risico's en dient u op de hoogte te zijn van de standaard procedures om ongelukken te voorkomen. Gebruik de nummers aan het eind van elke waarschuwing om deze te herleiden naar de desbetreffende locatie.

## BEWAAR DEZE INSTRUCTIES

### Installation Instructions



**Warning!** Read the installation instructions before connecting the system to the power source.

設置手順書

システムを電源に接続する前に、設置手順書をお読み下さい。

警告

将此系统连接电源前,请先阅读安装说明。

警告

將系統與電源連接前，請先閱讀安裝說明。

**Warnung**

Vor dem Anschließen des Systems an die Stromquelle die Installationsanweisungen lesen.

**¡Advertencia!**

Lea las instrucciones de instalación antes de conectar el sistema a la red de alimentación.

**Attention**

Avant de brancher le système sur la source d'alimentation, consulter les directives d'installation.

יש לקרוא את הוראות התקנה לפני חיבור המערכת למקור מתח.

اقر إرشادات التركيب قبل توصيل النظام إلى مصدر للطاقة

시스템을 전원에 연결하기 전에 설치 안내를 읽어주십시오.

**Waarschuwing**

Raadpleeg de installatie-instructies voordat u het systeem op de voedingsbron aansluit.

**Circuit Breaker**

**Warning!** This product relies on the building's installation for short-circuit (overcurrent) protection. Ensure that the protective device is rated not greater than: 250 V, 20 A.

**サーキット・ブレーカー**

この製品は、短絡(過電流)保護装置がある建物での設置を前提としています。

保護装置の定格が250 V、20 Aを超えないことを確認下さい。

**警告**

此产品的短路(过载电流)保护由建筑物的供电系统提供,确保短路保护设备的额定电流不大于250V,20A。

**警告**

此產品的短路(過載電流)保護由建築物的供電系統提供,確保短路保護設備的額定電流不大於250V,20A。

**Warnung**

Dieses Produkt ist darauf angewiesen, dass im Gebäude ein Kurzschluss- bzw. Überstromschutz installiert ist. Stellen Sie sicher, dass der Nennwert der Schutzvorrichtung nicht mehr als: 250 V, 20 A beträgt.

**¡Advertencia!**

Este equipo utiliza el sistema de protección contra cortocircuitos (o sobrecorrientes) del edificio. Asegúrese de que el dispositivo de protección no sea superior a: 250 V, 20 A.

**Attention**

Pour ce qui est de la protection contre les courts-circuits (surtension), ce produit dépend de l'installation électrique du local. Vérifiez que le courant nominal du dispositif de protection n'est pas supérieur à :250 V, 20 A.

מוצר זה מסתמך על הגנה המותקנת במבנים למניעת קצר חשמלי. יש לוודא כי המכשיר המגן מפני הקצר החשמלי הוא לא יותר מ-250VDC, 20A

هذا المنتج يعتمد على معدات الحماية مه الدوائر القصيرة التي تم تثبيتها في المبنى  
تأكد من أن تقييم الجهاز الوقائي ليس أكثر من : 20A, 250V

**경고!**

이 제품은 전원의 단락(과전류)방지에 대해서 전적으로 건물의 관련 설비에 의존합니다. 보호장치의 정격이 반드시 250V(볼트), 20A(암페어)를 초과하지 않도록 해야 합니다.

**Waarschuwing**

Dit product is afhankelijk van de kortsluitbeveiliging (overspanning) van uw elektrische installatie. Controleer of het beveiligde apparaat niet groter gedimensioneerd is dan 250V, 20A.

## Power Disconnection Warning



**Warning!** The system must be disconnected from all sources of power and the power cord removed from the power supply module(s) before accessing the chassis interior to install or remove system components (except for hot-swap components).



### 電源切断の警告

システムコンポーネントの取り付けまたは取り外しのために、シャーシ内部にアクセスするには、システムの電源はすべてのソースから切断され、電源コードは電源モジュールから取り外す必要があります。

### 警告

在你打开机箱并安装或移除内部器件前,必须将系统完全断电,并移除电源线。

### 警告

在您打開機殼安裝或移除內部元件前，必須將系統完全斷電，並移除電源線。

### Warnung

Das System muss von allen Quellen der Energie und vom Netzanschlusskabel getrennt sein, das von den Spg.Versorgungsteilmodulen entfernt wird, bevor es auf den Chassisinnenraum zurückgreift, um Systemsbestandteile anzubringen oder zu entfernen.

### ¡Advertencia!

El sistema debe ser disconnected de todas las fuentes de energía y del cable eléctrico quitado de los módulos de fuente de alimentación antes de tener acceso el interior del chasis para instalar o para quitar componentes de sistema.

### Attention

Le système doit être débranché de toutes les sources de puissance ainsi que de son cordon d'alimentation secteur avant d'accéder à l'intérieur du chassis pour installer ou enlever des composants de système.

אזהרה מפני ניתוק חשמלי

אזהרה!

יש לנתק את המערכת מכל מקורות החשמל ויש להסיר את כבל החשמלי מהספק לפני גישה לחלק הפנימי של המארז לצורך התקנת או הסרת רכיבים.

يجب فصل انظاؤ من جميع مصادر انطاقت وإزانت سهك انكهرباء من وحدة امداد انطاقت قيم

انصل إلى امناطق انداخييت نههيكم نشييج أو إزانت مكنناث الجهاز

경고!

시스템에 부품들을 장착하거나 제거하기 위해서는 새시 내부에 접근하기 전에 반드시 전원 공급장치로부터 연결되어있는 모든 전원과 전기코드를 분리해주어야 합니다.

Waarschuwing

Voordat u toegang neemt tot het binnenwerk van de behuizing voor het installeren of verwijderen van systeem onderdelen, dient u alle spanningsbronnen en alle stroomkabels aangesloten op de voeding(en) van de behuizing te verwijderen

## Equipment Installation



**Warning!** Only authorized personnel and qualified service persons should be allowed to install, replace, or service this equipment.

機器の設置

トレーニングを受け認定された人だけがこの装置の設置、交換、またはサービスを許可されています。

警告

只有经过培训且具有资格的人员才能进行此设备的安装、更换和维修。

警告

只有經過受訓且具資格人員才可安裝、更換與維修此設備。

Warnung

Nur autorisiertes Personal und qualifizierte Servicetechniker dürfen dieses Gerät installieren, austauschen oder warten..

¡Advertencia!

Sólo el personal autorizado y el personal de servicio calificado deben poder instalar, reemplazar o dar servicio a este equipo.

**Attention**

Seul le personnel autorisé et le personnel de maintenance qualifié doivent être autorisés à installer, remplacer ou entretenir cet équipement..

אזהרה!

יש לאפשר רק צוות מורשה ואנשי שירות מוסמכים להתקין, להחליף או לטפל בציוד זה.

ينبغي السماح فقط للموظفين المعتمدين وأفراد الخدمة المؤهلين بتركيب هذا الجهاز أو استبداله أو صيانته.

**경고!**

승인된 직원과 자격을 갖춘 서비스 담당자만이 이 장비를 설치, 교체 또는 서비스할 수 있습니다.

**Waarschuwing**

Alleen geautoriseerd personeel en gekwalificeerd onderhoudspersoneel mag deze apparatuur installeren, vervangen of onderhouden..

**Restricted Area**

**Warning!** This unit is intended for installation in restricted access areas. A restricted access area can be accessed only through the use of a special tool, lock and key, or other means of security. (This warning does not apply to workstations).

**アクセス制限区域**

このユニットは、アクセス制限区域に設置されることを想定しています。

アクセス制限区域は、特別なツール、鍵と錠前、その他のセキュリティの手段を用いてのみ出入りが可能です。

**警告**

此部件应安装在限制进出的场所，限制进出的场所指只能通过使用特殊工具、锁和钥匙或其它安全手段进出的场所。

**警告**

此裝置僅限安裝於進出管制區域，進出管制區域係指僅能以特殊工具、鎖頭及鑰匙或其他安全方式才能進入的區域。

**Warnung**

Diese Einheit ist zur Installation in Bereichen mit beschränktem Zutritt vorgesehen. Der Zutritt zu derartigen Bereichen ist nur mit einem Spezialwerkzeug, Schloss und Schlüssel oder einer sonstigen Sicherheitsvorkehrung möglich.

**¡Advertencia!**

Esta unidad ha sido diseñada para instalación en áreas de acceso restringido. Sólo puede obtenerse acceso a una de estas áreas mediante la utilización de una herramienta especial, cerradura con llave u otro medio de seguridad.

**Attention**

Cet appareil doit être installée dans des zones d'accès réservés. L'accès à une zone d'accès réservé n'est possible qu'en utilisant un outil spécial, un mécanisme de verrouillage et une clé, ou tout autre moyen de sécurité.

אזור עם גישה מוגבלת

אזהרה!

יש להתקין את היחידה באזורים שיש בהם הגבלת גישה. הגישה ניתנת בעזרת 'כלי אבטחה בלבד' (מפתח, מנעול וכד.).

تخصيص هذه انحدة نترك بها ف مناطق محظورة تم .

،ممكن اننصل إن منطقت محظورة فقط من خلال استخذاو أداة خاصت أو أ وس هُت أخري نلالأمما ققم ومفتاح

**경고!**

이 장치는 접근이 제한된 구역에 설치하도록 되어있습니다. 특수도구, 잠금 장치 및 키, 또는 기타 보안 수단을 통해서만 접근 제한 구역에 들어갈 수 있습니다.

**Waarschuwing**

Dit apparaat is bedoeld voor installatie in gebieden met een beperkte toegang. Toegang tot dergelijke gebieden kunnen alleen verkregen worden door gebruik te maken van speciaal gereedschap, slot en sleutel of andere veiligheidsmaatregelen.

## Battery Handling



**CAUTION:** There is risk of explosion if the battery is replaced by an incorrect type. Replace the battery only with the same or equivalent type recommended by the manufacturer. Dispose of used batteries according to the manufacturer's instructions

### 電池の取り扱い

バッテリーを間違ったタイプに交換すると爆発の危険があります。交換する電池はメーカーが推奨する型、または同等のものを使用下さい。使用済電池は製造元の指示に従って処分して下さい。

### 警告

如果更换的电池类型不正确，则存在爆炸危险。请只使用同类电池或制造商推荐的功能相当的电池更换原有电池。请按制造商的说明处理废旧电池。

### 警告

如果更換的電池類型不正確，則有爆炸危險。請使用製造商建議之相同或功能相當的電池更換原有電池。請按照製造商的說明指示處理廢棄舊電池。

### WARNUNG

Es besteht Explosionsgefahr, wenn die Batterie durch einen falschen Typ ersetzt wird. Ersetzen Sie die Batterie nur durch den gleichen oder vom Hersteller empfohlenen Batterietyp. Entsorgen Sie die benutzten Batterien nach den Anweisungen des Herstellers.

### ATTENTION

Il existe un risque d'explosion si la batterie est remplacée par un type incorrect. Ne la remplacer que par une pile de type semblable ou équivalent, recommandée par le fabricant. Jeter les piles usagées conformément aux instructions du fabricant.

### ADVERTENCIA

Existe riesgo de explosión si la batería se reemplaza por un tipo incorrecto. Reemplazar la batería exclusivamente con el mismo tipo o el equivalente recomendado por el fabricante. Desechar las baterías gastadas según las instrucciones del fabricante.

אזהרה!

קיימת סכנת פיצוץ אם הסוללה תוחלף בסוג שגוי. יש להחליף את הסוללה בסוג התואם מחברת יצרן מומלצת. סילוק הסוללות המשומשות יש לבצע לפי הוראות היצרן.

هناك خطر الانفجار إذا تم استبدال البطارية بنوع غير صحيح.  
 اسحبذال البطارية  
 فقط بنفس النوع أو ما يعادلها مما أوصت به الشركة المصنعة  
 جخلص من البطاريات المسحعملة وفقا لعمليات الشركة الصانعة

경고!

배터리를 잘못된 종류로 교체하면 폭발의 위험이 있습니다. 기존 배터리와 동일하거나 제조사에서 권장하는 동등한 종류의 배터리로만 교체해야 합니다. 제조사의 안내에 따라 사용된 배터리를 처리하여 주십시오.

#### WAARSCHUWING

Er bestaat explosiegevaar als de batterij wordt vervangen door een verkeerd type. Vervang de batterij slechts met hetzelfde of een equivalent type die door de fabrikant aanbevolen wordt. Gebruikte batterijen dienen overeenkomstig fabrieksvoorschriften afgevoerd te worden.

### Redundant Power Supplies



**Warning!** This unit might have more than one power supply connection. All connections must be removed to de-energize the unit.

冗長電源装置

このユニットは複数の電源装置が接続されている場合があります。

ユニットの電源を切るためには、すべての接続を取り外さなければなりません。

警告

此部件连接的电源可能不止一个，必须将所有电源断开才能停止给该部件供电。

警告

此装置连接的电源可能不只一个，必须切断所有电源才能停止对该装置的供电。

Warnung

Dieses Gerät kann mehr als eine Stromzufuhr haben. Um sicherzustellen, dass der Einheit kein Strom zugeführt wird, müssen alle Verbindungen entfernt werden.

## ¡Advertencia!

Puede que esta unidad tenga más de una conexión para fuentes de alimentación. Para cortar por completo el suministro de energía, deben desconectarse todas las conexiones.

## Attention

Cette unité peut avoir plus d'une connexion d'alimentation. Pour supprimer toute tension et tout courant électrique de l'unité, toutes les connexions d'alimentation doivent être débranchées.

אם קיים יותר מספק אחד

אזהרה!

ליחידה יש יותר מחיבור אחד של ספק. יש להסיר את כל החיבורים על מנת לרוקן את היחידה.

قد يكون لهذا الجهاز عدة اتصالات بوحدات امداد الطاقة .

يجب إزالة كافة الاتصالات لعسل الوحدة عن الكهرباء

## 경고!

이 장치에는 한 개 이상의 전원 공급 단자가 연결되어 있을 수 있습니다. 이 장치에 전원을 차단하기 위해서는 모든 연결 단자를 제거해야만 합니다.

## Waarschuwing

Deze eenheid kan meer dan één stroomtoevoeraansluiting bevatten. Alle aansluitingen dienen verwijderd te worden om het apparaat stroomloos te maken.

## Backplane Voltage



**Warning!** Hazardous voltage or energy is present on the backplane when the system is operating. Use caution when servicing.

バックプレーンの電圧

システムの稼働中は危険な電圧または電力が、バックプレーン上にかかっています。

修理する際には注意ください。

警告

当系统正在进行时，背板上有很危险的电压或能量，进行维修时务必小心。

警告

當系統正在進行時，背板上有危險的電壓或能量，進行維修時務必小心。

Warnung

Wenn das System in Betrieb ist, treten auf der Rückwandplatine gefährliche Spannungen oder Energien auf. Vorsicht bei der Wartung.

¡Advertencia!

Cuando el sistema está en funcionamiento, el voltaje del plano trasero es peligroso. Tenga cuidado cuando lo revise.

Attention

Lorsque le système est en fonctionnement, des tensions électriques circulent sur le fond de panier. Prendre des précautions lors de la maintenance.

מתח בפנל האחורי

אזהרה!

קיימת סכנת מתח בפנל האחורי בזמן תפעול המערכת. יש להיזהר במהלך העבודה.

هناك خطر من التيار الكهربائي أو الطاقة المتجددة على اللوحة  
عندما يكون النظام يعمل كه حذرا عند خدمة هذا الجهاز

경고!

시스템이 동작 중일 때 후면판 (Backplane)에는 위험한 전압이나 에너지가 발생 합니다.  
서비스 작업 시 주의하십시오.

Waarschuwing

Een gevaarlijke spanning of energie is aanwezig op de backplane wanneer het systeem in gebruik is. Voorzichtigheid is geboden tijdens het onderhoud.

## Comply with Local and National Electrical Codes



**Warning!** Installation of the equipment must comply with local and national electrical codes.

地方および国の電気規格に準拠

機器の取り付けはその地方および国の電気規格に準拠する必要があります。

警告

设备安装必须符合本地与本国电气法规。

警告

設備安裝必須符合本地與本國電氣法規。

Warnung

Die Installation der Geräte muss den Sicherheitsstandards entsprechen.

¡Advertencia!

La instalación del equipo debe cumplir con las normas de electricidad locales y nacionales.

Attention

L'équipement doit être installé conformément aux normes électriques nationales et locales.

תיאום חוקי החשמל הארצי  
אזהרה!  
התקנת הציוד חייבת להיות תואמת לחוקי החשמל המקומיים והארציים.

تركيب المعدات الكهربائية يجب أن يمتثل للقوايه المحلية والبطية المتعلقة  
بالكهرباء

경고!

현 지역 및 국가의 전기 규정에 따라 장비를 설치해야 합니다.

Waarschuwing

Bij installatie van de apparatuur moet worden voldaan aan de lokale en nationale elektriciteitsvoorschriften.

## Product Disposal



**Warning!** Ultimate disposal of this product should be handled according to all national laws and regulations.

製品の廃棄

この製品を廃棄処分する場合、国の関係する全ての法律・条例に従い処理する必要があります。

警告

本产品的废弃处理应根据所有国家的法律和规章进行。

警告

本產品的廢棄處理應根據所有國家的法律和規章進行。

Warnung

Die Entsorgung dieses Produkts sollte gemäß allen Bestimmungen und Gesetzen des Landes erfolgen.

¡Advertencia!

Al deshacerse por completo de este producto debe seguir todas las leyes y reglamentos nacionales.

## Attention

La mise au rebut ou le recyclage de ce produit sont généralement soumis à des lois et/ou directives de respect de l'environnement. Renseignez-vous auprès de l'organisme compétent.

סילוק המוצר

אזהרה!

סילוק סופי של מוצר זה חייב להיות בהתאם להנחיות וחוקי המדינה.

التخلص النهائي من هذا المنتج ينبغي التعامل معه وفقا لجميع القوانين واللوائح الوطنية عند

경고!

이 제품은 해당 국가의 관련 법규 및 규정에 따라 폐기되어야 합니다.

## Waarschuwing

De uiteindelijke verwijdering van dit product dient te geschieden in overeenstemming met alle nationale wetten en reglementen.

## Fan Warning



**Warning!** Hazardous moving parts. Keep away from moving fan blades. The fans might still be turning when you remove the fan assembly from the chassis. Keep fingers, screwdrivers, and other objects away from the openings in the fan assembly's housing.

ファンの警告

警告!回転部品に注意。運転中は回転部(羽根)に触れないでください。シャーシから冷却ファン装置を取り外した際、ファンがまだ回転している可能性があります。ファンの開口部に、指、ドライバー、およびその他のものを近づけないで下さい。

警告!

警告! 危險的可移動性零件。請務必與轉動的风扇叶片保持距離。當您從機架移除風扇裝置，風扇可能仍在轉動。小心不要將手指、螺絲起子和其他物品太靠近風扇

警告

危險的可移動性零件。請務必與轉動的风扇叶片保持距離。當您從機架移除風扇裝置，風扇可能仍在轉動。小心不要將手指、螺絲起子和其他物品太靠近風扇。

**Warnung**

Gefährlich Bewegende Teile. Von den bewegenden Lüfterblätter fern halten. Die Lüfter drehen sich u. U. noch, wenn die Lüfterbaugruppe aus dem Chassis genommen wird. Halten Sie Finger, Schraubendreher und andere Gegenstände von den Öffnungen des Lüftergehäuses entfernt.

**¡Advertencia!**

Riesgo de piezas móviles. Mantener alejado de las aspas del ventilador. Los ventiladores podran dar vuelta cuando usted quite el montaje del ventilador del chasis. Mantenga los dedos, los destornilladores y todos los objetos lejos de las aberturas del ventilador

**Attention**

Pieces mobiles dangereuses. Se tenir a l'écart des lames du ventilateur Il est possible que les ventilateurs soient toujours en rotation lorsque vous retirerez le bloc ventilateur du châssis. Prenez garde à ce que doigts, tournevis et autres objets soient éloignés du logement du bloc ventilateur.

**אזהרה!**

חלקים נעים מסוכנים. התרחק מלהבי המאוורר בפעולה כאשר מסירים את חלקי המאוורר מהמארז, יתכן והמאווררים עדיין עובדים. יש להרחיק למרחק בטוח את האצבעות וכלי עבודה שונים מהפתחים בתוך המאוורר

تحذير! أجزاء متحركة خطيرة. ابتعد عن شفرات المروحة المتحركة. من الممكن أن المراوح لا تزال تدور عند إزالة كتلة المروحة من الهيكل يجب إبقاء الأصابع ومفكات البراغي وغيرها من الأشياء بعيدا عن الفتحات في كتلة المروحة

**경고!**

움직이는 위험한 부품. 회전하는 송풍 날개에 접근하지 마세요. 새시로부터 팬 조립품을 제거할 때 팬은 여전히 회전하고 있을 수 있습니다. 팬 조립품 외관의 열려있는 부분들로부터 손가락 및 스크류드라이버, 다른 물체들이 가까이 하지 않도록 배치해 주십시오.

**Waarschuwing**

Gevaarlijk bewegende onderdelen. Houd voldoende afstand tot de bewegende ventilatorbladen. Het is mogelijk dat de ventilator nog draait tijdens het verwijderen van het ventilatorsamenstel uit het chassis. Houd uw vingers, schroevendraaiers en eventuele andere voorwerpen uit de buurt van de openingen in de ventilatorbehuizing.

## Power Cable and AC Adapter



**Warning!** When installing the product, use the provided or designated connection cables, power cables and AC adapters. Using any other cables and adapters could cause a malfunction or a fire. Electrical Appliance and Material Safety Law prohibits the use of UL or CSA -certified cables (that have UL/CSA shown on the cord) for any other electrical devices than products designated by Supermicro only.

### 電源コードとACアダプター

製品を設置する場合、提供または指定および購入された接続ケーブル、電源コードとACアダプターを該当する地域の条例や安全基準に適合するコードサイズやプラグと共に使用下さい。他のケーブルやアダプタを使用すると故障や火災の原因になることがあります。

電気用品安全法は、ULまたはCSA認定のケーブル(UL/CSAマークがコードに表記)を Supermicro が指定する製品以外に使用することを禁止しています。

### 警告

安装此产品时,请使用本身提供的或指定的或采购的连接线,电源线和电源适配器。包含遵照当地法规和安全要求的合规的电源线尺寸和插头。使用其它线材或适配器可能会引起故障或火灾。除了Supermicro所指定的产品,电气用品和材料安全法律规定禁止使用未经UL或CSA认证的线材。(线材上会显示UL/CSA符号)。

### 警告

安裝此產品時,請使用本身提供的或指定的或採購的連接線,電源線和電源適配器。包含遵照當地法規和安全要求的合規的電源線尺寸和插頭。使用其它線材或適配器可能會引起故障或火災。除了Supermicro所指定的產品,電氣用品和材料安全法律規定禁止使用未經UL或CSA認證的線材。(線材上會顯示UL/CSA符號)。

### Warnung

Nutzen Sie beim Installieren des Produkts ausschließlich die von uns zur Verfügung gestellten Verbindungskabeln, Stromkabeln und/oder Adapter, die Ihre örtlichen Sicherheitsstandards einhalten. Der Gebrauch von anderen Kabeln und Adapter können Fehlfunktionen oder Feuer verursachen. Die Richtlinien untersagen das Nutzen von UL oder CAS zertifizierten Kabeln (mit UL/CSA gekennzeichnet), an Geräten oder Produkten die nicht mit Supermicro gekennzeichnet sind.

## ¡Advertencia!

Cuando instale el producto, utilice la conexión provista o designada o procure cables, Cables de alimentación y adaptadores de CA que cumplan con los códigos locales y los requisitos de seguridad, incluyendo el tamaño adecuado del cable y el enchufe. El uso de otros cables y adaptadores podría causar un mal funcionamiento o un incendio. La Ley de Seguridad de Aparatos Eléctricos y de Materiales prohíbe El uso de cables certificados por UL o CSA (que tienen el certificado UL / CSA en el código) para cualquier otros dispositivos eléctricos que los productos designados únicamente por Supermicro.

## Attention

Lors de l'installation du produit, utilisez les cables de connection fournis ou désigné ou achetez des cables, cables de puissance et adaptateurs respectant les normes locales et les conditions de securite y compris les tailles de cables et les prises electriques appropriées. L'utilisation d'autres cables et adaptateurs peut provoquer un dysfonctionnement ou un incendie. Appareils électroménagers et la Loi sur la Sécurité Matériel interdit l'utilisation de câbles certifiés- UL ou CSA (qui ont UL ou CSA indiqué sur le code) pour tous les autres appareils électriques sauf les produits désignés par Supermicro seulement.

AC ימאתמו מילמשח מילבכ

!הרהזא

ךרוצל ומאתוה וא ושכרנ רשא AC מימאתמו מיקפס, מילבכב שמתשהל שי, רצומה תא מיניקתמ רשאכ לכב שומיש . עקתהו לבכה לש הנוכח הדימ ללוכ, תוימוקמה תוחיטבה תושירדל ומאתוה רשאו, הנקתהה למשחה ירישכמב שומישה יקוחל מאתהב. ילמשח רצק וא הלקתל מורגל לולע, רחא גוסמ מאתמ וא לבכ לש דוק מהילע עיפומ רשאכ) UL-ב או CSA-ב -ב מיכמומה מילבכב שמתשהל רוסיא מייק, תוחיטבה יקוחו דבלב Supermicro י"ע מאתוה רשא רצומב קר אלא, רחא ילמשח רצומ לכ רובע (UL/CSA)

תאלבאלא אארשב מץ וא ענדחמלא וא ערפוטמלא תאליצוולא מאדחטסאב מץ, גתנמלא בייקרת דנע לכלז יפ אמב עילחמלא עמאלסלא תאבלטתמו נינאווקב מאזתלאלא עמ דדרתמלא ראיטלא תאלוחמו עיזאברמלא קיירח וא לטע יפ בבסטטי דץ ירזא תאלוחמו תאלבאלא יא מאדחטסא. מילסלא סבאלאו לטוולא מץ ח. CSA וא UL לבק נמ ענדחמלא תאלבאלא מאדחטסא תאדעמלא עיזאברמלא עזחאלל עמאלסלא נונאק רזחי Supermicro לבק נמ ענדחמלא עינעמלא תאגתנמלא ריזא ירזא תאדעמ יא עמ (UL/CSA) עמאלע למחתיטלאו

### 전원 케이블 및 AC 어댑터

경고! 제품을 설치할 때 현지 코드 및 적절한 굵기의 코드와 플러그를 포함한 안전 요구 사항을 준수하여 제공되거나 지정된 연결 혹은 구매 케이블, 전원 케이블 및 AC 어댑터를 사용하십시오.

다른 케이블이나 어댑터를 사용하면 오작동이나 화재가 발생할 수 있습니다. 전기 용품 안전법은 UL 또는 CSA 인증 케이블 (코드에 UL / CSA가 표시된 케이블)을 Supermicro가 지정한 제품 이외의 전기 장치에 사용하는 것을 금지합니다.

### Stroomkabel en AC-Adapter

Waarschuwing! Bij het aansluiten van het Product uitsluitend gebruik maken van de geleverde Kabels of een andere geschikte aan te schaffen Aansluitmethode, deze moet altijd voldoen aan de lokale voorschriften en veiligheidsnormen, inclusief de juiste kabeldikte en stekker. Het gebruik van niet geschikte Kabels en/of Adapters kan een storing of brand veroorzaken. Wetgeving voor Elektrische apparatuur en Materiaalveiligheid verbied het gebruik van UL of CSA -gecertificeerde Kabels (met UL/CSA in de code) voor elke andere toepassing dan de door Supermicro hiervoor beoogde Producten.

# Appendix B

## System Specifications

### Processors

Supports dual 4th and 5th Gen Intel Xeon Scalable processors, in Socket E (LGA 4677), thermal design power (TDP) of up to 350W.

- 4th Gen: up to 60 cores and supports SP XCC, SP MCC, and Max Series (HBM) SKUs.
- 5th Gen: up to 64 cores and supports SP XCC and SP MCC SKUs.

### Chipset

Intel PCH C741

### BIOS

AMI 32 MB SPI Flash EEPROM

### Memory

Supports up to 8 TB 3DS RDIMM/RDIMM DDR5 (288-pin) ECC memory with speeds up to 5600 MT/s (1PDC) or 4400 MT/s (2DPC) in 32 DIMM slots

**Note:** Memory speed and capacity support depends on the processors used in the system.

### GPUs

Eight AMD Instinct MI300X GPUs

### Storage Drives

Twelve PCIe 5.0 x4 NVMe U.2

Two onboard NVMe M.2

Eight 2.5" SATA

### PCI Expansion Slots

8x PCIe 5.0 x16 HHHL

2x PCIe 5.0 x16 FHHL

(Optional) 2x PCIe 5.0 x16 FHHL

### Input/Output

One VGA port

Two USB 3.0 ports

One Dedicated IPMI RJ45 port

### Motherboard

X13DEG-M: 14.95" (W) X 17.00" (L) (379.73 mm x 431.8 mm)

### Chassis

CSE-GP801TS: 8U Rackmount, 17.2" x 14" x 33.2" (depth) (43.7 x 356 x 843 cm)

### System Cooling

Five front and five rear 8-cm fans with optimal fan speed control

GPU air blockers, motherboard air shrouds

### Power Supply

(Six default) PWS-3K06G-2R, 3000 W 4 + 2 redundant modules, 80Plus Titanium level

Input:

2880 W: 200-207 Vac, 16-15.7 A, 50-60 Hz

3000 W: 207.1-240 Vac, 16-14.5 A, 50-60 Hz

3000 W: 240 Vdc, 15 A

DC Output:

+54 V, 45 A

+12 V, 91.66 A

+12 Vsb, 3 A

**Operating Environment**

Operating Temperature: 10° to 35° C (50° to 95° F)

Non-operating Temperature: -40° to 60° C (-40° to 140° F)

Operating Relative Humidity: 8% to 90% (non-condensing)

Non-operating Relative Humidity: 5% to 95% (non-condensing)

**Regulatory Compliance**

FCC, ICES, CE, VCCI, RCM, UKCA, NRTL, CB

**Applied Directives, Standards**

EMC/EMI: 2014/30/EU (EMC Directive)

Electromagnetic Compatibility Regulations 2016

FCC Part 15

ICES-003

VCCI-CISPR 32

AS/NZS CISPR 32

BS/EN55032

BS/EN55035

CISPR 32

CISPR 35

BS/EN 61000-3-2

BS/EN 61000-3-3

BS/EN 61000-4-2

BS/EN 61000-4-3

BS/EN 61000-4-4

BS/EN 61000-4-5

BS/EN 61000-4-6

BS/EN 61000-4-8

BS/EN 61000-4-11

Environment:

Delegated Directive (EU) 2015/863

Directive 2011/65/EU (RoHS)

REACH Regulation EC 1907/2006

WEEE Directive 2012/19/EU

California Proposition 65

Product Safety: 2014/35/EU (LVD Directive)

UL/CSA 62368-1 (USA and Canada)

Electrical Equipment (Safety) Regulations 2016

IEC/BS/EN 62368-1

**Perchlorate Warning**

California Best Management Practices Regulations for Perchlorate Materials: This Perchlorate warning applies only to products containing CR (Manganese Dioxide) Lithium coin cells. "Perchlorate Material-special handling may apply. See [www.dtsc.ca.gov/hazardouswaste/perchlorate](http://www.dtsc.ca.gov/hazardouswaste/perchlorate)"

この装置は、クラスA機器です。この装置を住宅環境で使用すると電波妨害を引き起こすことがあります。この場合には使用者が適切な対策を講ずるよう要求されることがあります。

VCCI — A

## **General Data Center Environmental Specifications**

### Particulate contamination specifications

Air filtration: Data centers must be kept clean to Class 8 of ISO 14644-1 (ISO 2015). The air entering the data center should be filtered with a MERV 11 filter or better. The air within the data center should be continuously filtered with a MERV 8 filter or better.

Conductive dust: Air should be free of conductive dust, zinc whiskers, or other conductive particles.

Corrosive dust: Air should be free of corrosive dust.

### Gaseous\* contamination specifications

Copper coupon corrosion rate: <300 Å/month per class G1 as defined by ANSI/ISA71.04-2013, referenced by ASHRAE TC 9.9

Silver coupon corrosion rate: <200 Å/month per class G1 as defined by ANSI/ISA71.04-2013, referenced by ASHRAE TC 9.9

\*If testing with silver or copper coupons results in values less than 200 Å/month or 300 Å/month, respectively, then operating up to 70% relative humidity (RH) is acceptable. If the testing shows corrosion levels exceed these limits, then catalyst-type pollutants are probably present and RH should be driven to 50% or lower.