

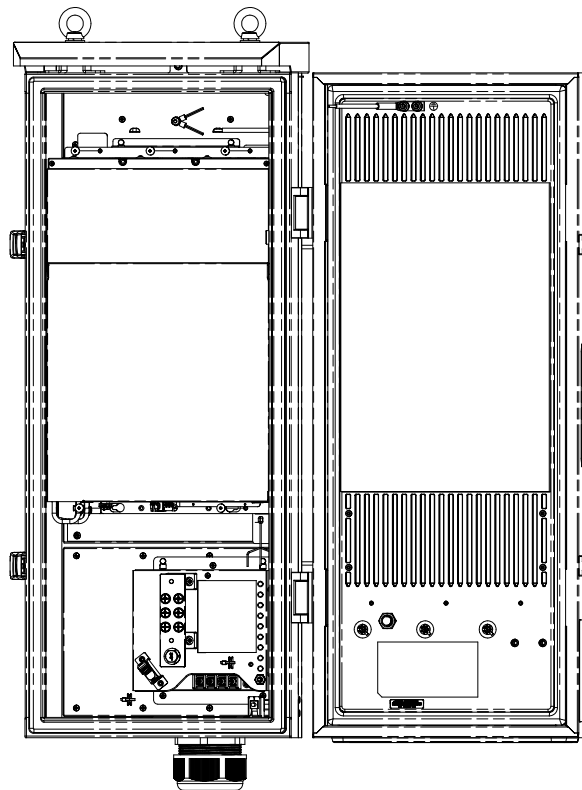

SuperServer[®]
SYS-E403-9D-16C-IPD2
SYS-E403-9D-14CN-IPD2



USER'S MANUAL

Revision 1.0a

The information in this User's Manual has been carefully reviewed and is believed to be accurate. The vendor assumes no responsibility for any inaccuracies that may be contained in this document, and makes no commitment to update or to keep current the information in this manual, or to notify any person or organization of the updates. Please Note: For the most up-to-date version of this manual, please see our website at www.supermicro.com.

Super Micro Computer, Inc. ("Supermicro") reserves the right to make changes to the product described in this manual at any time and without notice. This product, including software and documentation, is the property of Supermicro and/or its licensors, and is supplied only under a license. Any use or reproduction of this product is not allowed, except as expressly permitted by the terms of said license.

IN NO EVENT WILL Super Micro Computer, Inc. BE LIABLE FOR DIRECT, INDIRECT, SPECIAL, INCIDENTAL, SPECULATIVE OR CONSEQUENTIAL DAMAGES ARISING FROM THE USE OR INABILITY TO USE THIS PRODUCT OR DOCUMENTATION, EVEN IF ADVISED OF THE POSSIBILITY OF SUCH DAMAGES. IN PARTICULAR, SUPER MICRO COMPUTER, INC. SHALL NOT HAVE LIABILITY FOR ANY HARDWARE, SOFTWARE, OR DATA STORED OR USED WITH THE PRODUCT, INCLUDING THE COSTS OF REPAIRING, REPLACING, INTEGRATING, INSTALLING OR RECOVERING SUCH HARDWARE, SOFTWARE, OR DATA.

Any disputes arising between manufacturer and customer shall be governed by the laws of Santa Clara County in the State of California, USA. The State of California, County of Santa Clara shall be the exclusive venue for the resolution of any such disputes. Supermicro's total liability for all claims will not exceed the price paid for the hardware product.

FCC Statement: This equipment has been tested and found to comply with the limits for a Class A or Class B digital device pursuant to Part 15 of the FCC Rules. These limits are designed to provide reasonable protection against harmful interference when the equipment is operated in industrial environment for Class A device or in residential environment for Class B device. This equipment generates, uses, and can radiate radio frequency energy and, if not installed and used in accordance with the manufacturer's instruction manual, may cause harmful interference with radio communications. Operation of this equipment in a residential area is likely to cause harmful interference, in which case you will be required to correct the interference at your own expense.

California Best Management Practices Regulations for Perchlorate Materials: This Perchlorate warning applies only to products containing CR (Manganese Dioxide) Lithium coin cells. "Perchlorate Material-special handling may apply. See www.dtsc.ca.gov/hazardouswaste/perchlorate".



WARNING: This product can expose you to chemicals including lead, known to the State of California to cause cancer and birth defects or other reproductive harm. For more information, go to www.P65Warnings.ca.gov.

The products sold by Supermicro are not intended for and will not be used in life support systems, medical equipment, nuclear facilities or systems, aircraft, aircraft devices, aircraft/emergency communication devices or other critical systems whose failure to perform be reasonably expected to result in significant injury or loss of life or catastrophic property damage. Accordingly, Supermicro disclaims any and all liability, and should buyer use or sell such products for use in such ultra-hazardous applications, it does so entirely at its own risk. Furthermore, buyer agrees to fully indemnify, defend and hold Supermicro harmless for and against any and all claims, demands, actions, litigation, and proceedings of any kind arising out of or related to such ultra-hazardous use or sale.

Manual Revision 1.0a

Release Date: December 12, 2023

Unless you request and receive written permission from Super Micro Computer, Inc., you may not copy any part of this document. Information in this document is subject to change without notice. Other products and companies referred to herein are trademarks or registered trademarks of their respective companies or mark holders.

Copyright © 2023 by Super Micro Computer, Inc.
All rights reserved.

Printed in the United States of America

Preface

About this Manual

This manual is written for professional system integrators and PC technicians. It provides information for the installation and use of this system. Installation and maintenance should be performed by certified service technicians only.

Please refer to the SYS-E403-9D-16C-IPD2 or SYS-E403-9D-14CN-IPD2 server specifications page on our website for updates on supported memory, processors and operating systems (<http://www.supermicro.com>).

Notes

For your system to work properly, please follow the links below to download all necessary drivers/utilities and the user's manual for your server.

- Supermicro product manuals: <http://www.supermicro.com/support/manuals/>
- Product drivers and utilities: <https://www.supermicro.com/wdl>
- Product safety info: http://www.supermicro.com/about/policies/safety_information.cfm

If you have any questions, please contact our support team at: support@supermicro.com

This manual may be periodically updated without notice. Please check the Supermicro website for possible updates to the manual revision level.

Secure Data Deletion

A secure data deletion tool designed to fully erase all data from storage devices can be found on our website: https://www.supermicro.com/about/policies/disclaimer.cfm?url=/wdl/utility/Lot9_Secure_Data_Deletion_Utility/

Warnings

Special attention should be given to the following symbols used in this manual.



Warning! Indicates important information given to prevent equipment/property damage or personal injury.



Warning! Indicates high voltage may be encountered when performing a procedure.

Contents

| | |
|---|----|
| Contacting Supermicro..... | 7 |
| Chapter 1 Introduction | |
| 1.1 Overview..... | 8 |
| 1.2 System Features | 9 |
| Chipset Block Diagram..... | 10 |
| 1.3 Server Features..... | 11 |
| Control Panel | 11 |
| Server Front | 12 |
| Server Rear | 13 |
| 1.4 IP65 Enclosure | 14 |
| 1.5 Enclosure Health Diagnostics | 16 |
| Chapter 2 System Installation | |
| 2.1 Overview..... | 17 |
| Warnings | 17 |
| Caution | 17 |
| 2.2 Preparing for Setup..... | 18 |
| Pole Mounting Requirements..... | 18 |
| System Precautions | 18 |
| 2.3 Mounting Procedure | 19 |
| 2.4 Detaching the Cabinet Door..... | 23 |
| 2.5 Server Installation (if not pre-installed) | 24 |
| 2.6 Cabling Installation | 26 |
| Electrical Connections..... | 26 |
| Grounding Connections..... | 26 |
| Enclosure Connections | 27 |
| 2.7 Lightning Protector | 28 |
| Chapter 3 Maintenance and Component Installation | |
| 3.1 Removing Power | 30 |
| 3.2 Accessing the Server | 31 |
| 3.3 Replacing Enclosure Fans | 34 |
| 3.4 Processor | 35 |
| 3.5 Memory Support..... | 35 |
| ESD Precautions | 35 |

| | |
|--|-----|
| Memory Population Guidelines | 36 |
| DIMM Module Population Sequence | 37 |
| DIMM Installation | 38 |
| DIMM Removal | 38 |
| 3.6 M.2 SSD Installation..... | 39 |
| 3.7 Motherboard Battery..... | 40 |
| 3.8 Installing Storage Drives | 41 |
| 3.9 Expansion Cards | 43 |
| 3.10 Server Cooling | 45 |
| Server Fans..... | 45 |
| 3.11 Power Supply | 47 |
| Power Supply Failure | 47 |
| Chapter 4 Motherboard Connections | |
| 4.1 Motherboard Layout | 48 |
| Quick Reference Table..... | 50 |
| 4.2 Power Connections | 52 |
| 4.3 Headers and Connectors | 53 |
| 4.4 Ports | 60 |
| Rear I/O Ports | 60 |
| Front Control Panel..... | 63 |
| 4.5 Jumpers..... | 66 |
| Explanation of Jumpers | 66 |
| 4.6 LED Indicators..... | 70 |
| Chapter 5 Software | |
| 5.1 Driver Installation..... | 72 |
| 5.2 SuperDoctor® 5..... | 74 |
| 5.3 IPMI | 74 |
| Chapter 6 UEFI BIOS | |
| 6.1 Introduction..... | 75 |
| Starting the Setup Utility | 75 |
| 6.2 Main Setup | 76 |
| 6.3 Advanced..... | 77 |
| 6.4 Event Logs | 103 |
| 6.5 IPMI | 105 |
| 6.6 Security..... | 109 |

6.7 Boot 112
6.8 Save & Exit..... 114

Appendix A BIOS Error Codes

Appendix B Standardized Warning Statements for DC Systems

DC Power Disconnection 135
Hazardous Voltage or Energy Present on DC Power Terminals 137

Appendix C System Specifications

Appendix D UEFI BIOS Recovery Instructions

Appendix E IPMI Crash Dump

Contacting Supermicro

Headquarters

Address: Super Micro Computer, Inc.
980 Rock Ave.
San Jose, CA 95131 U.S.A.

Tel: +1 (408) 503-8000

Fax: +1 (408) 503-8008

Email: marketing@supermicro.com (General Information)
Sales-USA@supermicro.com (Sales Inquiries)
Government_Sales-USA@supermicro.com (Gov. Sales Inquiries)
support@supermicro.com (Technical Support)
RMA@supermicro.com (RMA Support)
Webmaster@supermicro.com (Webmaster)

Website: www.supermicro.com

Europe

Address: Super Micro Computer B.V.
Het Sterrenbeeld 28, 5215 ML
's-Hertogenbosch, The Netherlands

Tel: +31 (0) 73-6400390

Fax: +31 (0) 73-6416525

Email: Sales_Europe@supermicro.com (Sales Inquiries)
Support_Europe@supermicro.com (Technical Support)
RMA_Europe@supermicro.com (RMA Support)

Website: www.supermicro.nl

Asia-Pacific

Address: Super Micro Computer, Inc.
3F, No. 150, Jian 1st Rd.
Zhonghe Dist., New Taipei City 235
Taiwan (R.O.C)

Tel: +886-(2) 8226-3990

Fax: +886-(2) 8226-3992

Email: Sales-Asia@supermicro.com.tw (Sales Inquiries)
Support@supermicro.com.tw (Technical Support)
RMA@supermicro.com.tw (RMA Support)

Website: www.supermicro.com.tw

Chapter 1

Introduction

1.1 Overview

This chapter provides a brief outline of the functions and features of the outdoor DC platform SuperServer SYS-E403-9D-16C-IPD2/E403-9D-14CN-IPD2. Applications for these servers include 5G Radio Access Network (RAN), Multi-Access Edge Computing (MEC), Edge AI Inferencing, Vehicle to Everything (C-V2X/V2X) and Virtualized Functions and Services. The server is suitable for Network Telecommunication Facilities and Outside Plants. These Outdoor Edge systems are based on the E403-9D-14CN-FRDN13+/E403-9D-16C-FRDN13+ embedded server and the B403-IP65 IP65 Enclosure.

In addition to the server and chassis, several important parts that are included with the server are listed below.

| Main Parts List | | |
|-----------------------------------|----------------|----------|
| Description | Part Number | Quantity |
| Weather resistance IP65 enclosure | CSE-B403-IP65 | 1 |
| Power and control board | PDB-PT403-1400 | 1 |

| Model Variation Table | | | | |
|-----------------------|----------------------|--------------------|----------------|-------------------|
| SuperServer | Embedded Server | Motherboard | IP65 Enclosure | Power Dist. Board |
| E403-9D-14CN-IPD2 | E403-9D-14CN-FRDN13+ | X11SDW-14CN-TP13F+ | B403-IP65 | PDB-PT403-1400 |
| E403-9D-16C-IPD2 | E403-9D-16C-FRDN13+ | X11SDW-16C-TP13F+ | B403-IP65 | PDB-PT403-1400 |

Note: the following safety models associated with the SYS-E403-9D-16C-IPD2/E403-9D-14CN-IPD2 have been certified as compliant with UL or CSA: B403-IP and B403-IPOE.

1.2 System Features

The table below gives an overview of the main features included with the SuperServer SYS-E403-9D-16C-IPD2/E403-9D-14CN-IPD2.

| System Features |
|---|
| Processor |
| SYS-E403-9D-16C-IPD2: Single Intel® Xeon® D-2183IT SYS-E403-9D-14CN-IPD2: Single Intel® Xeon® D-2177NT |
| Motherboard |
| SYS-E403-9D-16C-IPD2: X11SDW-16C-TP13F+ SYS-E403-9D-14CN-IPD2: X11SDW-14CN-TP13F+ |
| Chassis |
| Enclosure: B403-IP65 Inner Chassis: CSE-E403iF-000NBP2 |
| Memory |
| Supports up to 256GB of ECC RDIMM or 512GB of ECC LRDIMM DDR4-2400 memory in four DIMM slots |
| Chipset |
| System on Chip |
| Expansion Slots |
| Either two PCIe 3.0 x16 or two PCIe 3.0 x8 + one PCIe 3.0 x16 (FHFL) slots One M.2 M-Key 2280/22110 (SATA3.0 / PCIe x4) One M.2 B-Key 2242/3042 (USB2.0 / USB3.0 / SATA3.0 / PCIe x2) One M.2 E-Key Slot 2230 (USB2.0 / PCIe x1) |
| Input/Output |
| USB: two USB 3.0 ports (front), two USB 2.0 ports (front) Serial Port: one COM via RJ45 Video: VGA port |
| Network |
| One RJ45 dedicated IPMI LAN port Four SPF+ ports Nine GbE LAN ports |
| Storage Drives |
| Four internal SATA3 2.5" drive bays, Intel® RSTe, RAID 0, 1, 5, 10 |
| Power |
| Enclosure: -44 to -59VDC power, 900W maximum Server: 600W -48VDC |
| Cooling |
| Enclosure: Three PWM redundant fans Server Chassis: Three 80x80mm PWM redundant fans |
| Dimensions (IP65 Enclosure) |
| IP65 Enclosure (WxHxD) 12.56 x 32.31 x 10.16 in. (319 x 821 x 258 mm) |

Chipset Block Diagram

The block diagram below shows the connections and relationships that exist in the chipset on the X11SDW-16C-TP13F+/X11SDW-14CN-TP13F+.

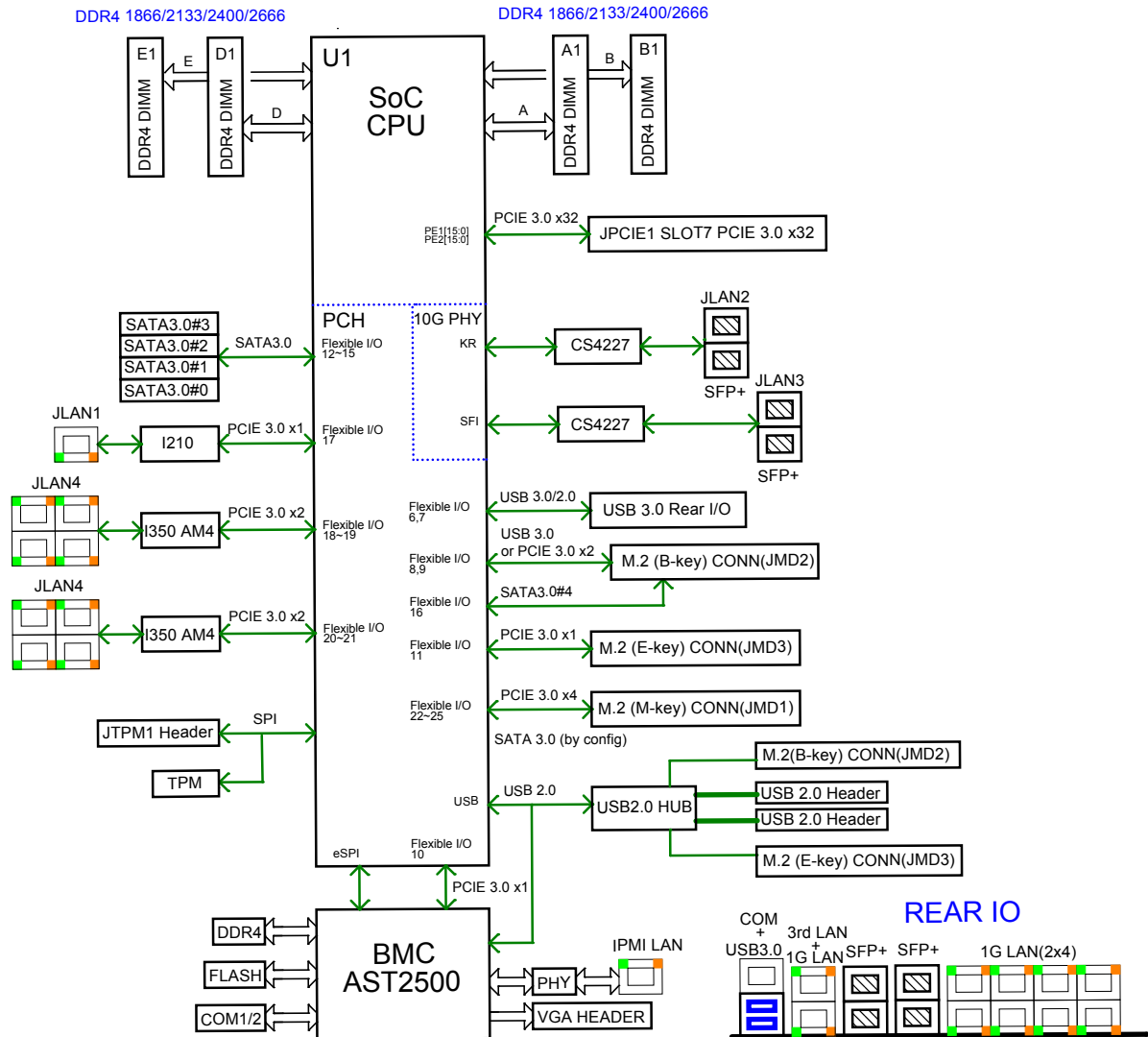

Figure 1-1. Chipset Block Diagram

Note: This is a general block diagram and may not exactly represent the features on your motherboard. See the System Specifications appendix for the actual specifications of your motherboard.

1.3 Server Features

The following features refer to the CSE-E403iF-000NBP2 chassis, which mounts inside of the B403-IP65 IP65 Enclosure

Control Panel

The power button and LEDs located on the control panel are described below.

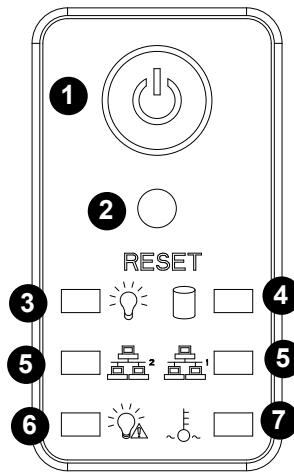

Figure 1-2. Control Panel View

| Control Panel Features | | |
|------------------------|-----------------|---|
| Item | Features | Description |
| 1 | Power Button | The main power switch applies or removes primary power from the power supply to the server but maintains standby power. To perform most maintenance tasks, unplug the system to remove all power. |
| 2 | Reset Button | Press the button with a slender instrument (like a pen) to reset the system. |
| 3 | Power LED | Indicates power is being supplied to the system power supply units. This LED is illuminated when the system is operating normally. |
| 4 | HDD LED | Indicates hard disk drive activity when flashing. |
| 5 | NIC LED | Indicates network activity on the LAN when flashing. |
| 6 | Information LED | Alerts operator to several states, as noted in the table on the next page. |
| 7 | Overheat LED | If this indicator is continuously on and red, an overheat condition has occurred. |

| Information LED | |
|-----------------------|--|
| Status | Description |
| Blinking red (1Hz) | Fan failure. Check for an inoperative fan. |
| Blinking red (0.25Hz) | Power failure. Check for a non-operational power supply. |

Server Front

The illustration below shows the features included on the front of the server.

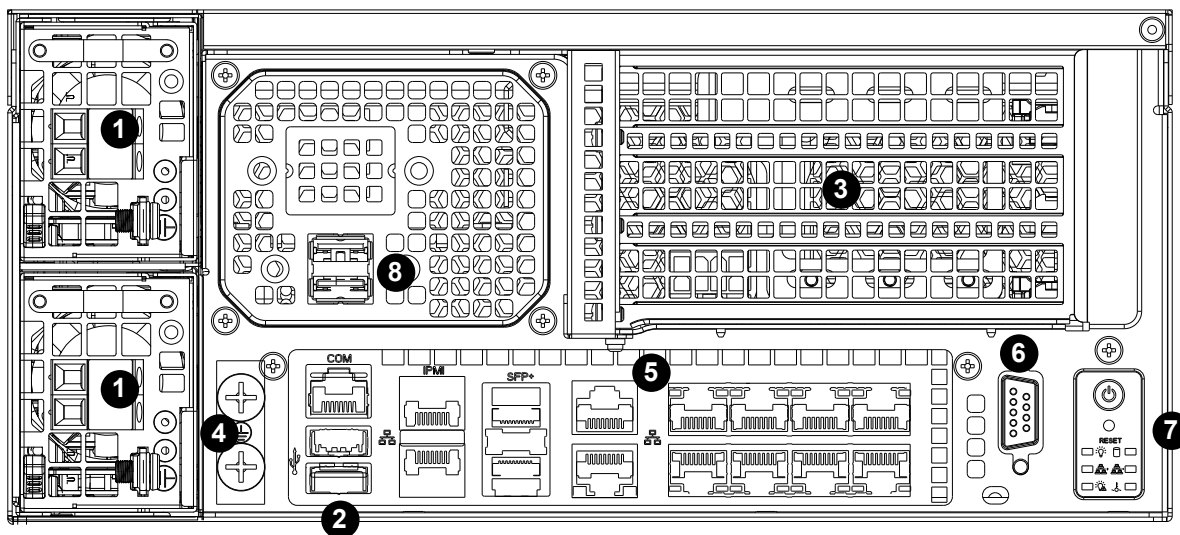

Figure 1-3. Server Front View

| Front Server Features | | |
|-----------------------|-----------------|---|
| Item | Features | Description |
| 1 | Power Supplies | Redundant 600W DC multi-output power supply modules. |
| 2 | USB Ports | External USB 3.0 Type-A ports. |
| 3 | PCI Slots | Three FH3/4L PCIe slots. |
| 4 | Ground | Two ground screws provided to connect the chassis to ground. |
| 5 | I/O Front Panel | Front panel for I/O devices supported on the motherboard (see Chapter 4). |
| 6 | VGA Port | VGA port. |
| 7 | Control Panel | System Control Panel |
| 8 | USB Ports | External USB 2.0 Type-A ports. |

Server Rear

The illustration below shows the features included on the rear of the server.

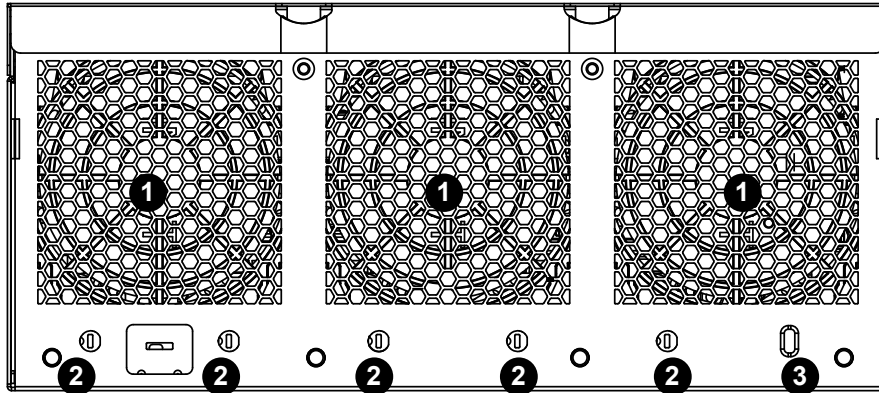

Figure 1-4. Server Rear View

| Rear Server Features | | |
|----------------------|---------------|----------------------------------|
| Item | Features | Description |
| 1 | Rear Fan | Three 80x80mm PWM redundant fans |
| 2 | Antenna Ports | Five antenna slots |
| 3 | Security Slot | Kensington® Security Lock |

1.4 IP65 Enclosure

The B403-IP65 IP65 Enclosure is designed to house a computer system in an outdoor environment. Accordingly, it can be mounted on poles, features a heater and a high-efficiency heat exchanger for ruggedized use, and includes lockable buckles and intrusion detection. See below for the main features of the B403-IP65.

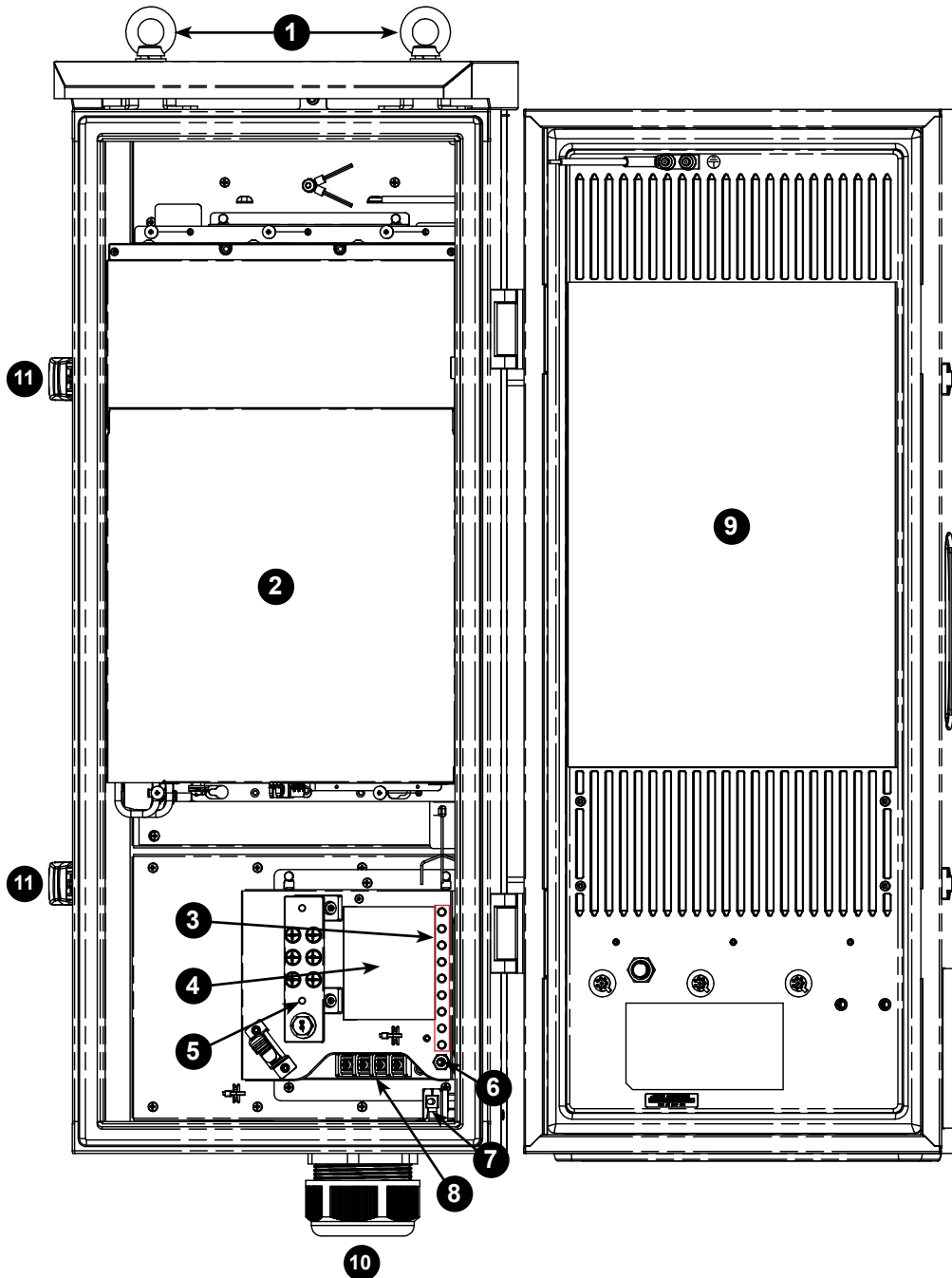

Figure 1-5. IP65 Enclosure Details

| IP65 Enclosure Features | | |
|--------------------------------|-----------------------|---|
| Item | Features | Description |
| 1 | Hoist Rings | Rings for lifting the system |
| 2 | Server | SYS-E403-9D-16C-IPD2 or SYS-E403-9D-14CN-IPD2 |
| 3 | Info LEDs | See table below for details. LEDs are numbered 1-9 from top to bottom. |
| 4 | Power & Control Board | Internal environment control |
| 5 | Grounding | Grounding strip |
| 6 | Test Button | Button to run self-diagnostics |
| 7 | Cabinet Intrusion | Intrusion mechanism to send notice that the enclosure has been opened |
| 8 | DC Power Input | DC power input terminal |
| 9 | Heat Exchanger | Transfers internal heat to external cooling airflow |
| 10 | Cable Gland | 2" cable gland for cable inlet/outlet (may be replaced with a 2" conduit hub) |
| 11 | Buckle | Used to lock the B403-IP65 enclosure |

| Info LEDs | | |
|------------------|--------------------|---|
| Number | Description | Indication |
| 1 | Thermal Sensor | Red light: thermal sensor fail |
| 2 | Server Power | Green light on: power is being supplied to the server Light off: no power being supplied to the server |
| 3 | Heater Power | Green light: heater is on Red light: heater fail Light off: heater is off |
| 4 | Control Power | Green light on: system in powered on Green light blinking: enclosure under test |
| 5 | Fan1 | Green: fan1 is operating Red: fan fail Light off: no power to Fan1 |
| 6 | Fan2 | Green: fan2 is operating Red: fan fail Light off: no power to Fan2 |
| 7 | Fan3 | Green: fan3 is operating Red: fan fail Light off: no power to Fan3 |
| 8 | Fan4 | Green: fan4 is operating Red: fan fail Light off: no power to Fan4 |
| 9 | Intrusion | Intrusion detected |

1.5 Enclosure Health Diagnostics

The enclosure has the ability to examine the health of its various components. By pressing the test button for at least three seconds, the enclosure will enter the diagnostic mode and the green LEDs will illuminate as shown in the left image below.

Press the test button again and a red LED pattern will illuminate, as shown in the middle image below. Do this to check if any LEDs are malfunctioning.

After checking the LEDs, press the test button once more and the enclosure will begin to test the sensors, the heater, and the fans. During this test, the control power LED will blink at 1Hz, and then at 4Hz to indicate the diagnostics have completed. If the test returns a normal status (no problems found), the LEDs will be shown in the right image below.

Press the test button a final time and the enclosure will return to normal operating mode.

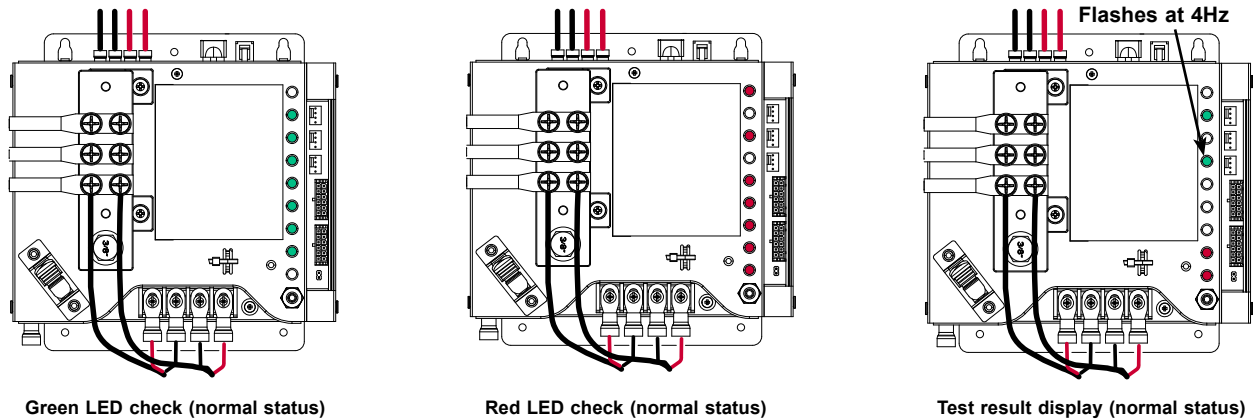

Figure 1-6. Health Diagnostic LED States

Chapter 2

System Installation

2.1 Overview

This chapter provides advice and instructions for attaching the SYS-E403-9D-16C-IPD2/E403-9D-14CN-IPD2 to a pole. If your system is not already fully integrated with system memory etc., refer to Chapter 3 for details on installing those specific components.

Warnings

- Installation work and electrical wiring must be done by qualified person(s) in accordance with all applicable codes, standards and national wiring regulations.
- Use this unit only in the manner intended by the manufacturer. If you have questions, please contact the manufacturer.
- Install the system in accordance with the instructions in this installation manual. Improper installation may result in electrical shock or fire.
- Make sure that all wiring is secured, the specified wires are used, and there is no strain on the terminal connections or wires.
- Before servicing or cleaning the unit, turn the power off and disconnect the power supply.
- Be sure to use only the specified accessories and parts for installation work.
- The system shall be not accessible to the general public.
- The product must be fixed in place before operation.

Caution

- Do not place any objects on/in the system.
- Do not block air inlets or outlets and do not touch the air inlets, outlets, or aluminum fins of the unit.
- Do not install the system in any place where there is a danger of flammable gas leakage.
- Be aware of any potential risks when installing, inspecting, maintaining, or repairing the system.

- Do not topple the system while in transport or storage.
- Please keep children away from the system.

2.2 Preparing for Setup

Pole Mounting Requirements

Manpower: Two people. Weight of system is 46kg (101lbs.)

Tools: Adjustable wrench with diameter 3/4 (19mm)
 Phillips and flathead screwdrivers
 Measuring tape
 Surge protection devices (SPD)
 Outdoor shielded dual-conductor cable (12 AWG)
 Outdoor grounding wire (6 AWG)
 Marking pen
 316L stainless hose clamp, 15mm or wider (optional)

System Precautions

- Review the electrical and general safety precautions in Appendix B.
- When not servicing, always keep all covers/panels on the server closed. These must be in place to allow for proper airflow and to prevent overheating.
- Keep a one-foot (30cm) clearance from the ground to provide sufficient airflow for cabinet cooling.
- Only install the system on a pole with a diameter of between 5" and 10".
- Ensure that the pole is capable to withstand the weight of the system before installation.
- Various pole types and materials are regulated in different regions, please refer to local regulations before mounting the system on a pole.
- Keep a four-foot (122cm) clearance around the pole to provide operating space.
- Use only the designed components and fasteners; using alternative components will invoke unpredictable risk.
- If surface paint becomes scratched or chipped off, touch it up with outdoor-use paint

2.3 Mounting Procedure

1. Remove the two screws under the mounting bracket to separate it from the cabinet.
2. Mark the desired mounting height.
3. Mount the bracket on the pole as illustrated in Figure 2-2, making sure it is firmly secured.

For Hose Clamp Rings:

- a. Orient the I-shaped mounting bracket to the top hanging hole.
- b. Push the mounting bracket firmly against the pole.
- c. Run the hose clamp around the pole and through the two hose clamp rings on the bracket and fasten tightly (first at the top and then the bottom).

For Threaded Rods:

- a. Assemble four threaded rods into the I-shaped mounting bracket with nuts and washers.
- b. Orient the mounting bracket to the top hanging hole (using caution to avoid injury).
- c. Push the mounting bracket firmly against the pole.
- d. Fasten the bracket to the two holding bars with four M12 screws and eight washers until tight.
4. Install the two hoist rings to the top of the system, making sure they are securely fastened.
5. Raise the system with the two hoist rings to the designated height (avoid scratching or casing damage to the surface paint).
6. Hook the system on the bracket as illustrated in Figure 2-3
7. Secure the cabinet to the bracket with the two screws removed from under the mounting bracket.

Important: if the surface coating is scratched or scraped off during transport or installation, the damaged surface must be touched up with appropriate external-use paint.

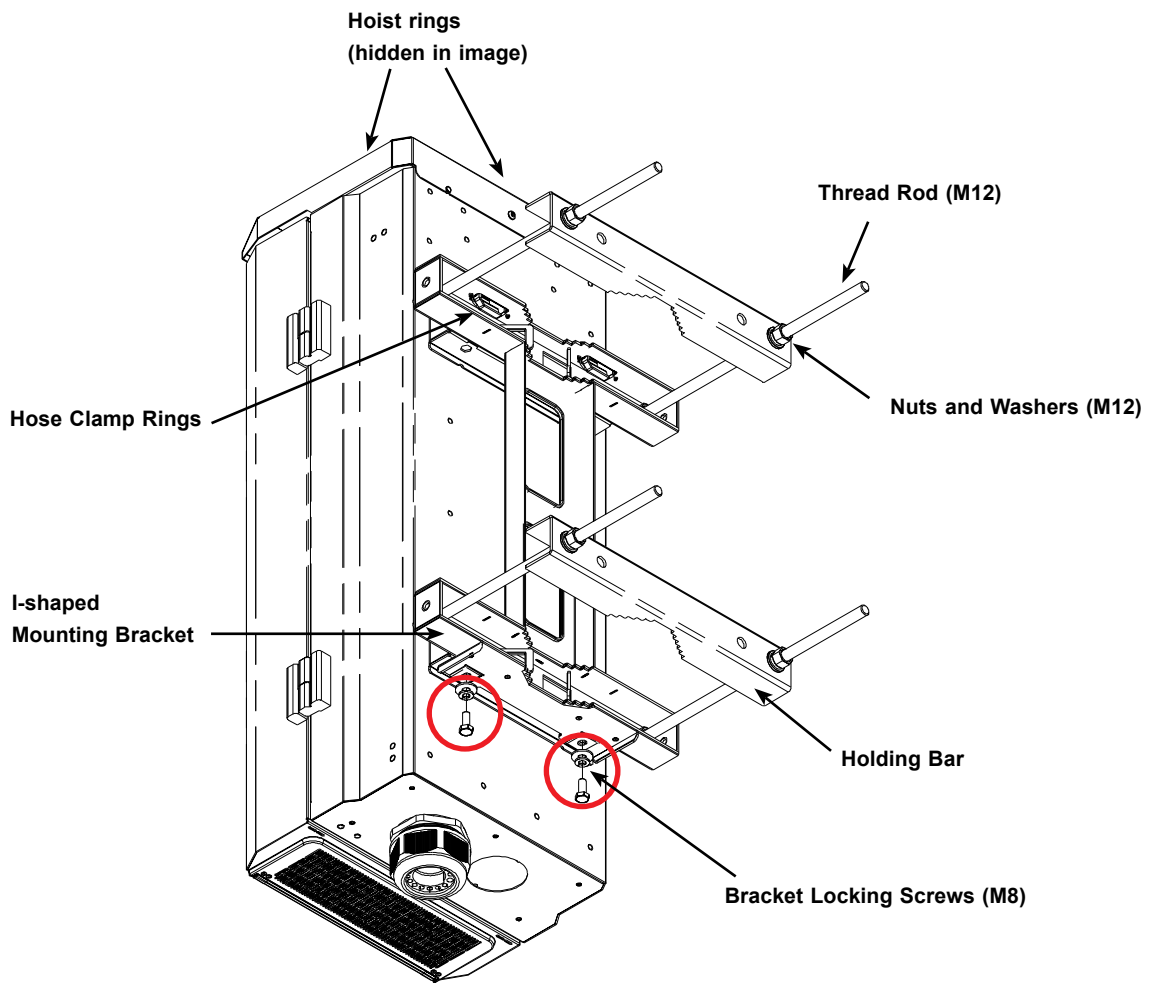
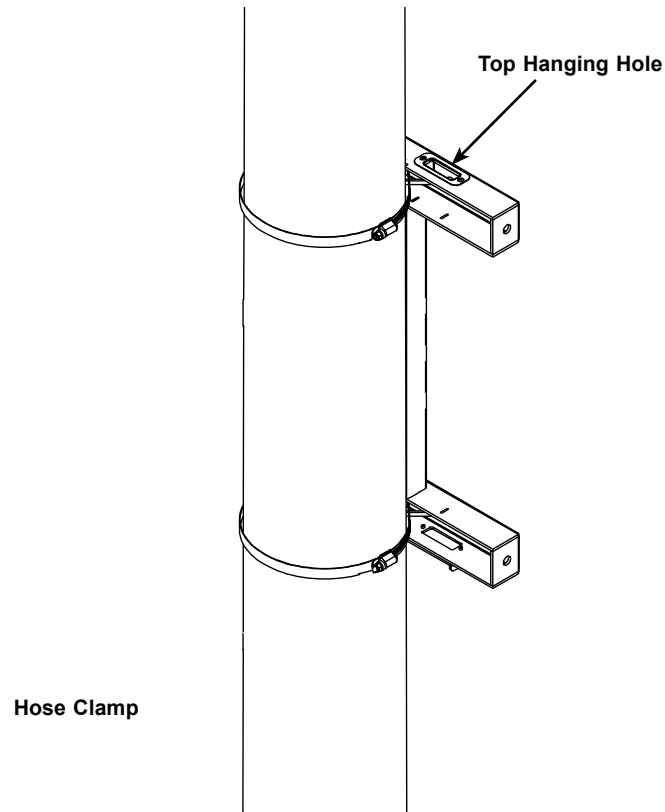

Figure 2-1. Removing the Screws from under the Mounting Bracket



Caution: if the pole's diameter is small enough, the hose clamp may double up (overlap) on itself. This should be avoided by cutting off any excess length.

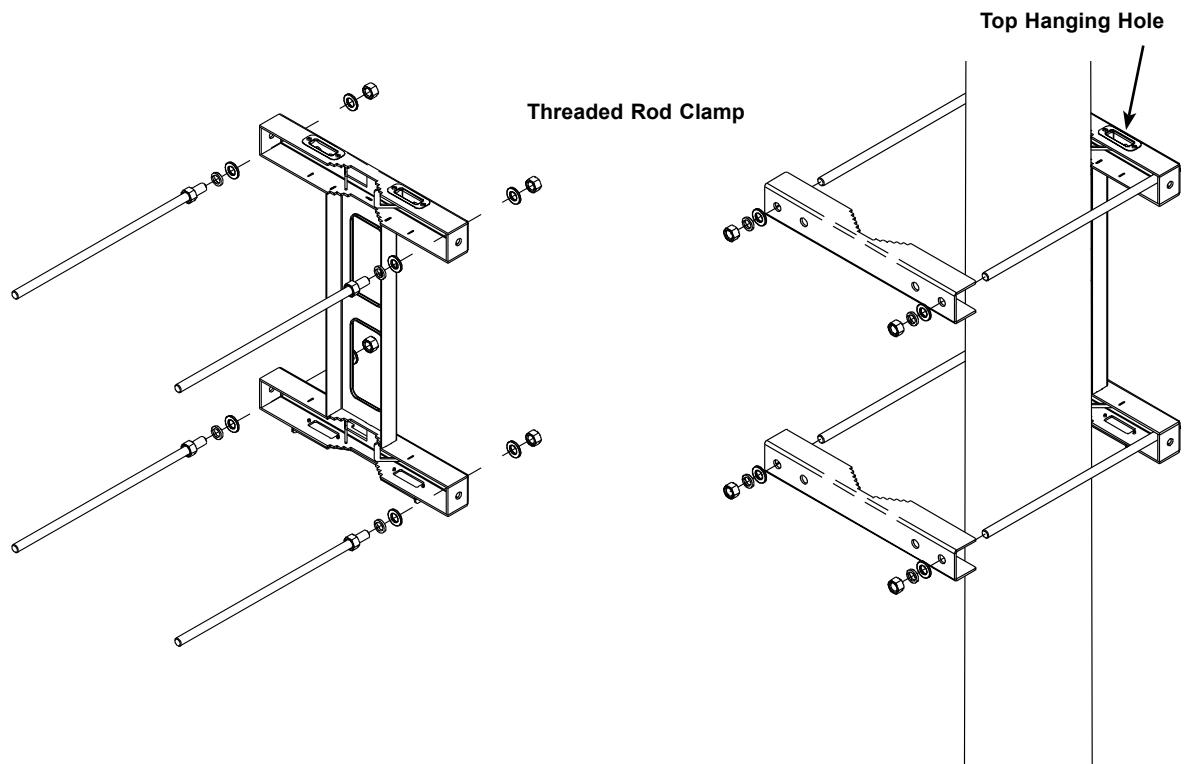

Figure 2-2. Attaching the Clamp to the Pole

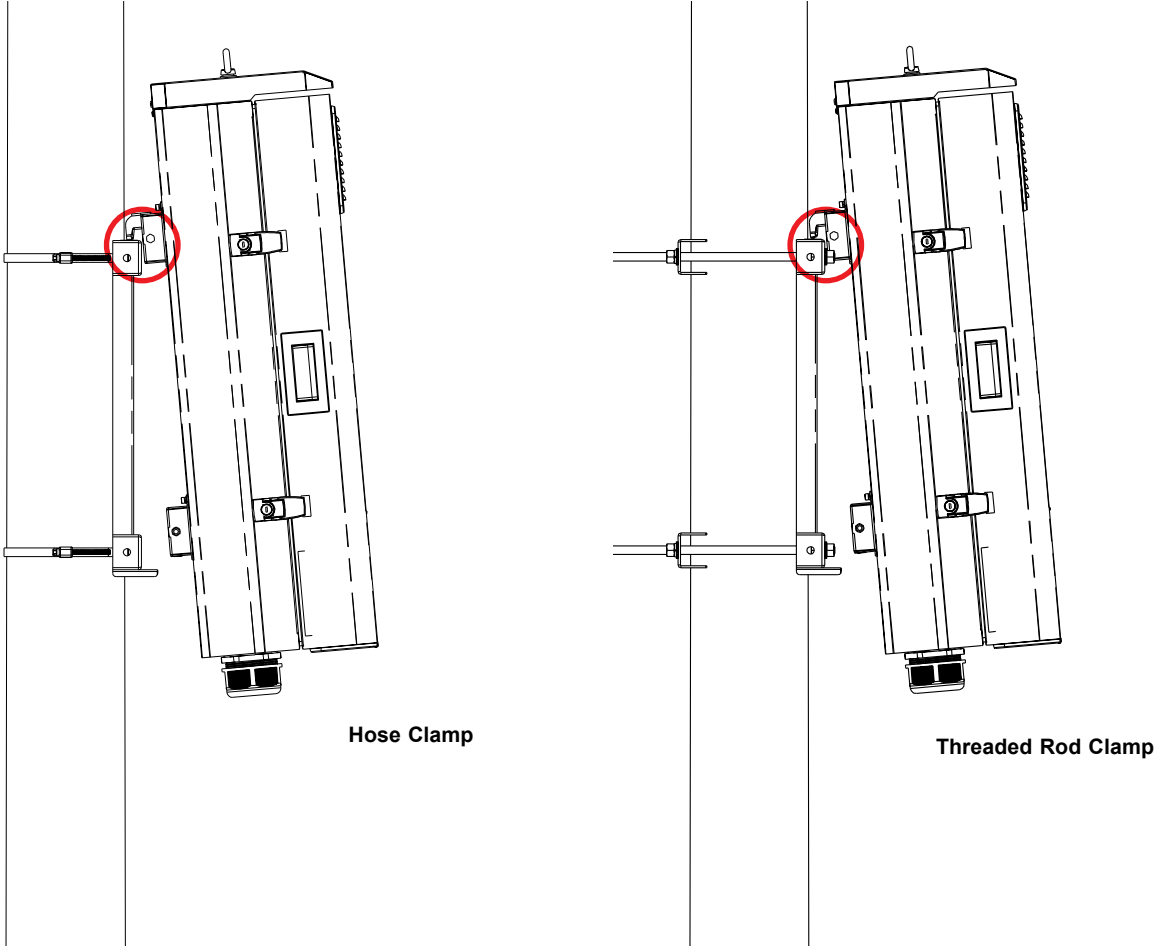

Figure 2-3. Hooking the Cabinet on the Bracket

2.4 Detaching the Cabinet Door

The enclosure allows the door to be detached to facilitate installation. However, the door was not designed to be lifted above seven feet on its own. If the system is to be deployed at a height above seven feet, please install the door to the enclosure first and then use the hoist rings to raise the entire enclosure to the desired height.

Detaching the Door

1. Disconnect the power cable from the system.
2. Unscrew the door stopper.
3. Open the door and place a proper support behind it.
4. Detach the two fan cables.
5. Detach the grounding cable attaching point and door retainer kit by unscrewing the three screws.
6. Make sure the door is opened more than 100 degrees, then carefully slide the door upwards to separate it from the enclosure.
7. To reattach the door, reverse the above steps. When reattaching the cables, pay attention to their tag labels to avoid mismatching them.

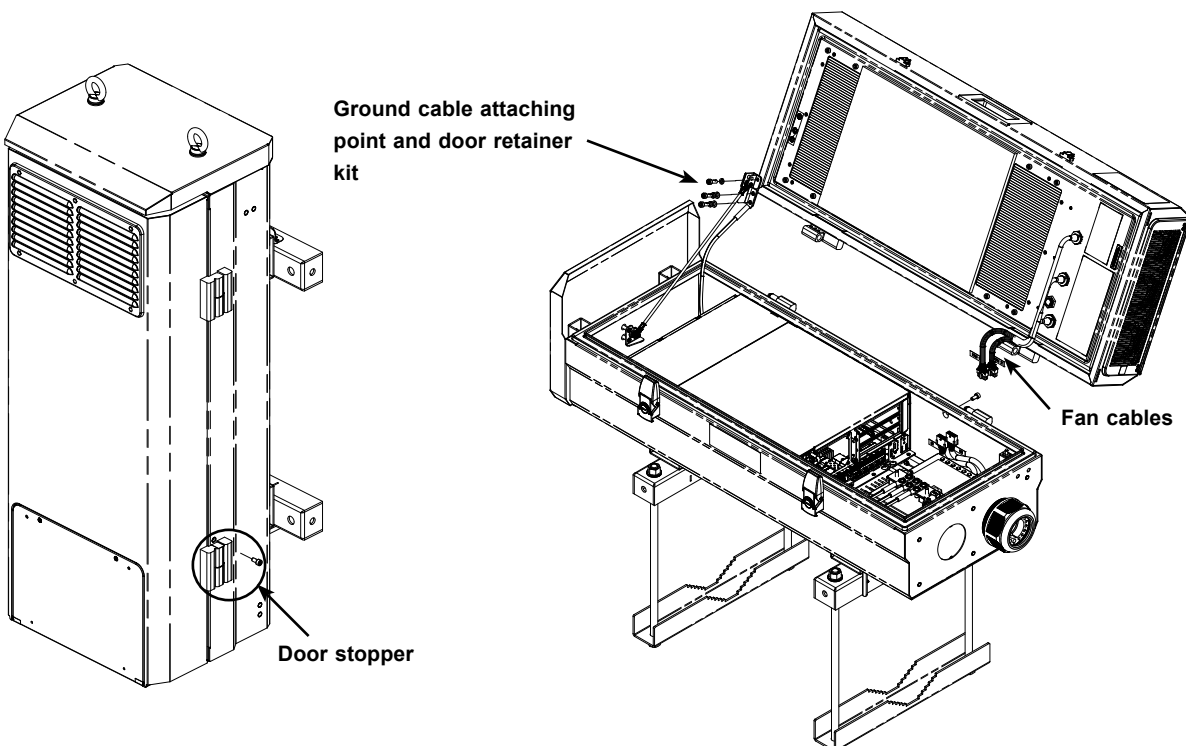

Figure 2-4. Detaching the Door

2.5 Server Installation (if not pre-installed)

If your server was not pre installed, please follow the steps below to install the server in the enclosure.

Installing the Server

1. Install the mounting bracket to the server

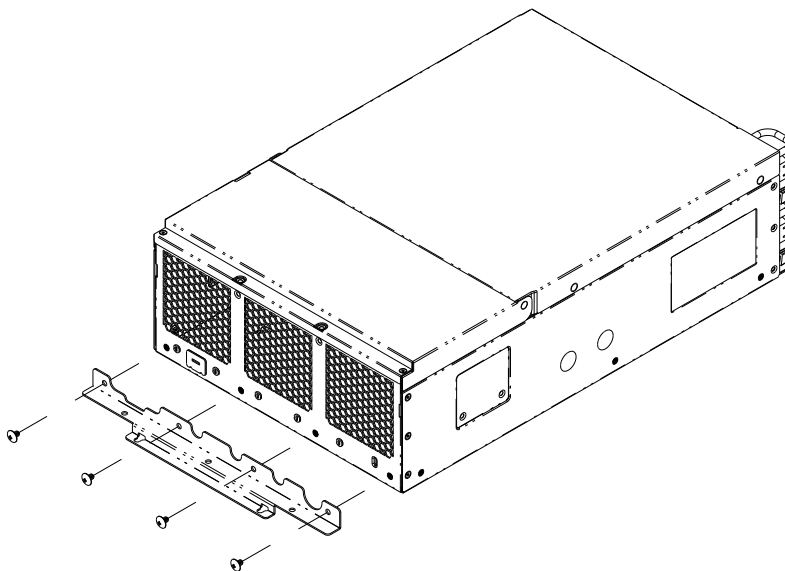

Figure 2-5. Installing the Bracket to the Server

2. Carefully hang the server in the enclosure using the two hanging inserts

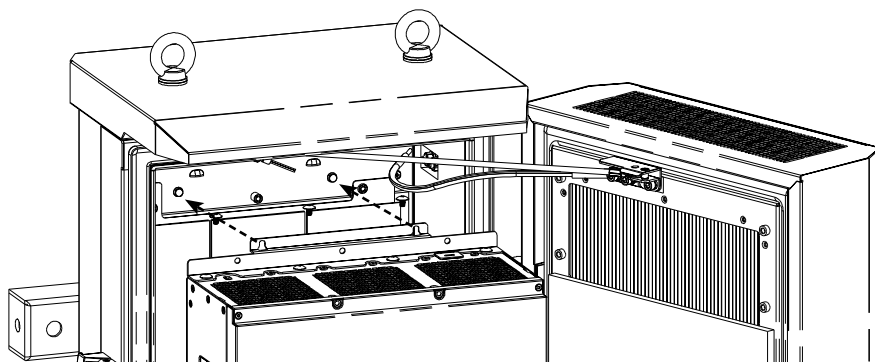

Figure 2-6. Location of Hanging Inserts

3. Secure the server by fastening the five M.4 screws

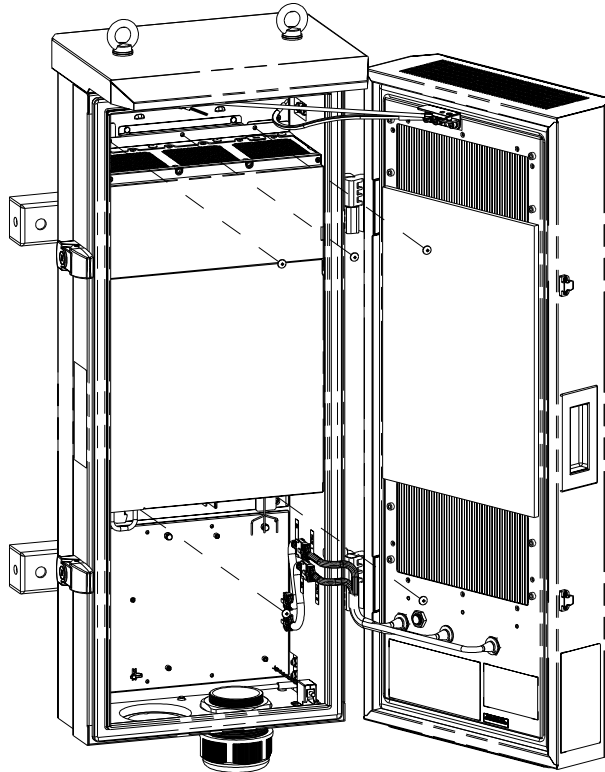

Figure 2-7. Securing the Server

4. Connect the power cable and ground (terminal lug) to the server.

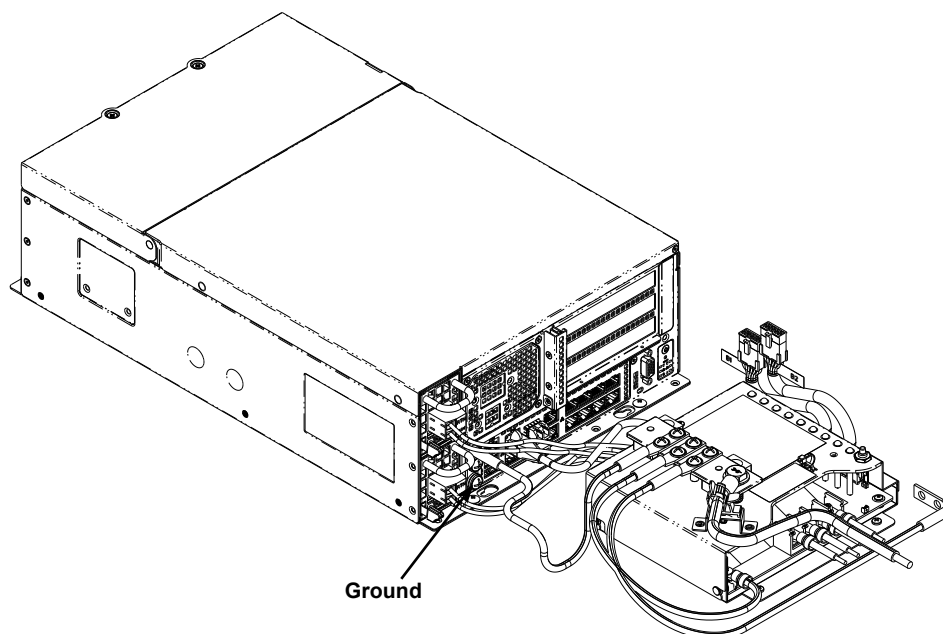

Figure 2-8. Connecting the Power and Ground

2.6 Cabling Installation

Electrical Connections

The electrical connections to the system are made on the power and control board. Open the enclosure to the B403-IP65 to gain access (see Figure 1-5 for the location of the power and control board).

Be aware that these connections have all been made. Note that the power and control board cover should not remain open due to safety concerns.

Grounding Connections

A ground bar is used to conduct the inner server chassis ground, the enclosure ground, and the power and control board ground to an earth ground. The outbound ground is connected with a 6 AWG wire, which can be part of Common Bonding Network (CBN), or an Isolated Bonding Network (IBN), or both. In addition, a cable retainer is provided to secure the outbound ground cable.

In general, the engineer will only need to connect the outbound ground. We recommend adding a ring terminal to ensure a good electrical contact.

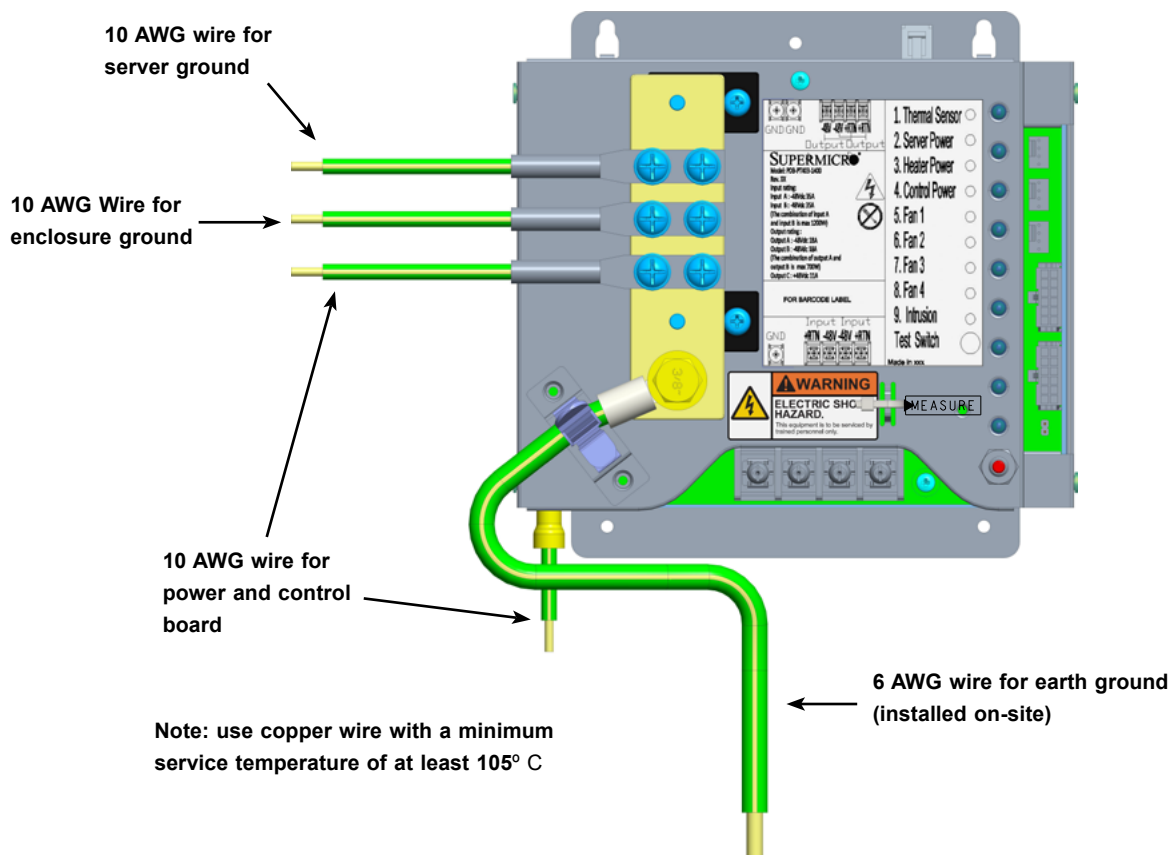

Figure 2-9. Grounding Connections

Enclosure Connections

Follow the steps below to install cables to the enclosure.

1. Unlock and release the buckles.
2. After ensuring there is ample swing space and no obstructions, open the system door.
3. Connect the grounding cable (6 AWG) as described in the previous section.
4. Cut off the power source if possible.
5. Run the power cord through the cable gland or conduit hub.
6. Install proper terminals at the end of the wires that will be attached to the system.
 - Bare conductors must be coated with an appropriate antioxidant compound before the crimp connections are made.
 - All listed fastening hardware must be compatible with the materials being joined and be free of loosening, deterioration, or electrochemical corrosion of the hardware and joined materials.
 - Non-conductive coatings on equipment to be bonded or grounded must be removed from threads and other contact surfaces to ensure electrical continuity. It is recommended that thread-forming type unit mounting screws that remove any paint or non-conductive coatings and establish metal-to-metal contact are used to meet this requirement.
7. Refer to Figure 2-10 to locate the Power Input Terminal Block and remove the plastic protective cap.
8. Connect the Return and the -48Vdc wire to the system and then replace the protective cap.
9. Install the SPD and connect the grounding and power cables to it (refer to Figure 2-6).
10. Prepare a second power cable and connect one end to the SPD DC-in.
11. Close the system door.
12. Connect the second power cable to the power source starting from the Return and then the -48Vdc.
13. Turn on the power source if applicable.

Note: When connecting the DC power input terminals to a power source, the battery return (BR) shall be treated as an isolated DC return (DC-I).

2.7 Lightning Protector

The SYS-E403-9D-16C-IPD2/E403-9D-14CN-IPD2 provides a dual power input option that allows you to attached two power sources. Certified Lightning Surge Protectors (SPD) are required for both power lines and copper communication cables (CAT cables). Silicon Avalanche Suppression Diodes (SASD) type SPDs with a capability of shunting a 5kA 8/20 μ s surge and multi-mode protection are recommended for the power line SPD.

The SPD may be installed either inside or outside of the enclosure, depending on the specification of the SPD. Figure 2-10 shows the cabling of an outdoor SPD.

The cabling between the SPD and the power and control board should be less than three feet in length. This is the A1 to B1 cable and the A2 to B2 cable as shown in Figure 2-10.

Warning:

Ensure that the ground has been properly connected before connecting the power source. Before connecting a power cable, ensure that the other end of the power cable is not connected to a power source.

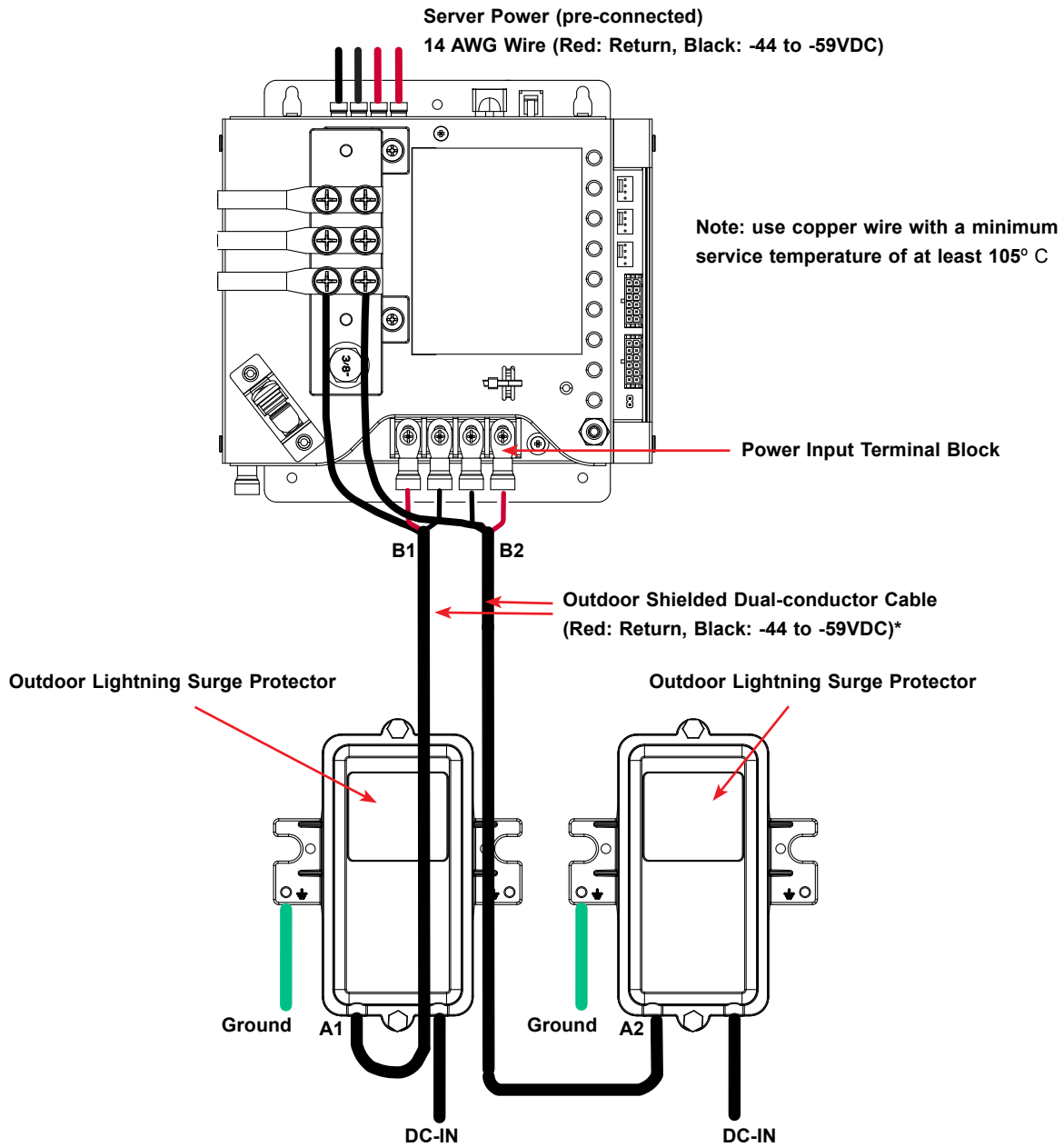

Figure 2-10. Power and Lighting Protector Connections

*This cable must be shorter than 3 feet in length.

Chapter 3

Maintenance and Component Installation

This chapter provides instructions on installing and replacing main system components. To prevent compatibility issues, only use components that match the specifications and/or part numbers given.

Installation or replacement of most components require that power first be removed from the system. Please follow the procedures given in each section.

3.1 Removing Power

Use the following procedure to ensure that power has been removed from the system.

1. Use the operating system to power down the system.
2. After the system has completely shut down, disconnect the power from the power source.
3. Disconnect the power cord from the server.

3.2 Accessing the Server

Open the fan cover to access the server fans. Remove the entire server cover to access other server components. Remove the hard drive cage, the expansion card module, and the air shroud to access the motherboard.

Accessing the Server Fans

The server fans can be accessed without powering down the system.

1. Remove the two screws on the fan cover. See the figure below.
2. Flip open the fan cover to access the server fans.

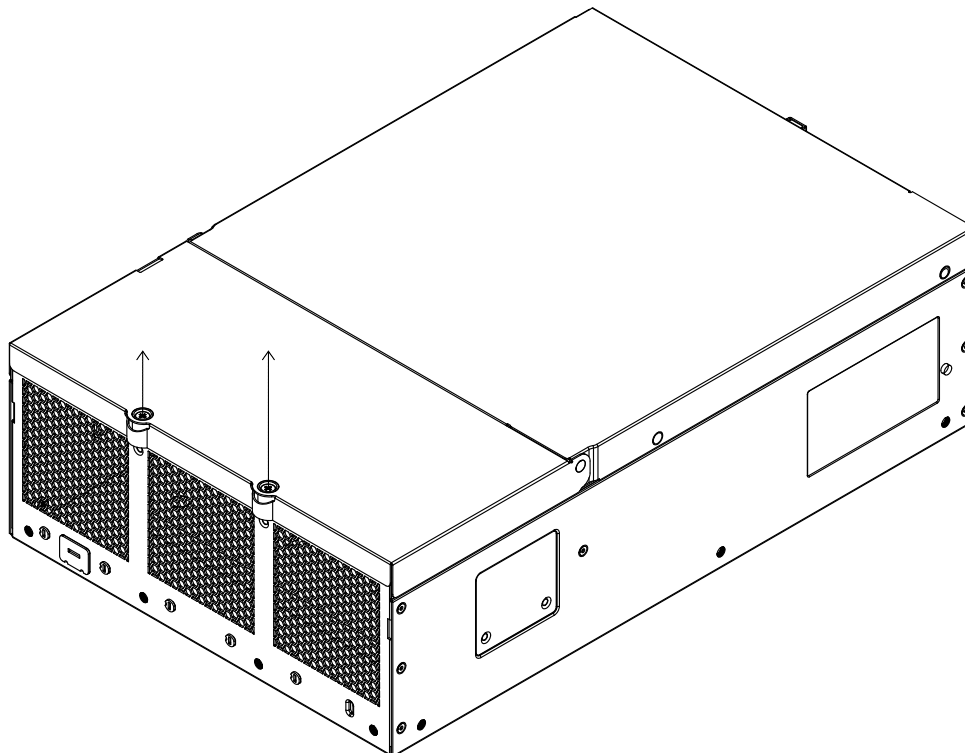

Figure 3-1. Removing Fan Cover Screws

Accessing the Main System

1. Power down the system as described in Section 3.1.
2. Remove one screw on top of the server cover near the I/O panel. See Figure 3-2.
3. Loosen the two thumbscrews screws on the fan cover.
4. Flip open the fan cover.
5. Remove the screw that has been exposed. See the figure below.
6. Slightly slide the server cover towards the fans.
7. Lift both segments of the top cover off the chassis.

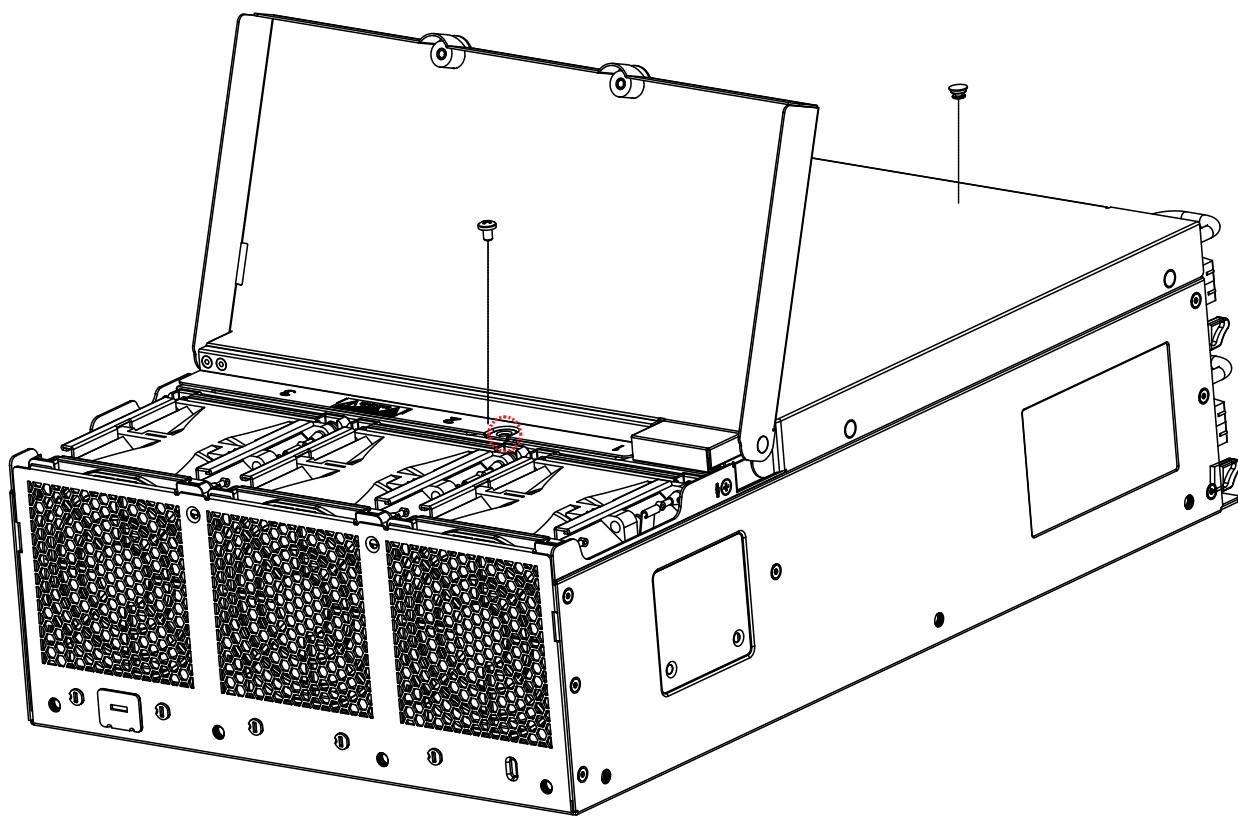

Figure 3-2. Open Fan Cover to Access Fans

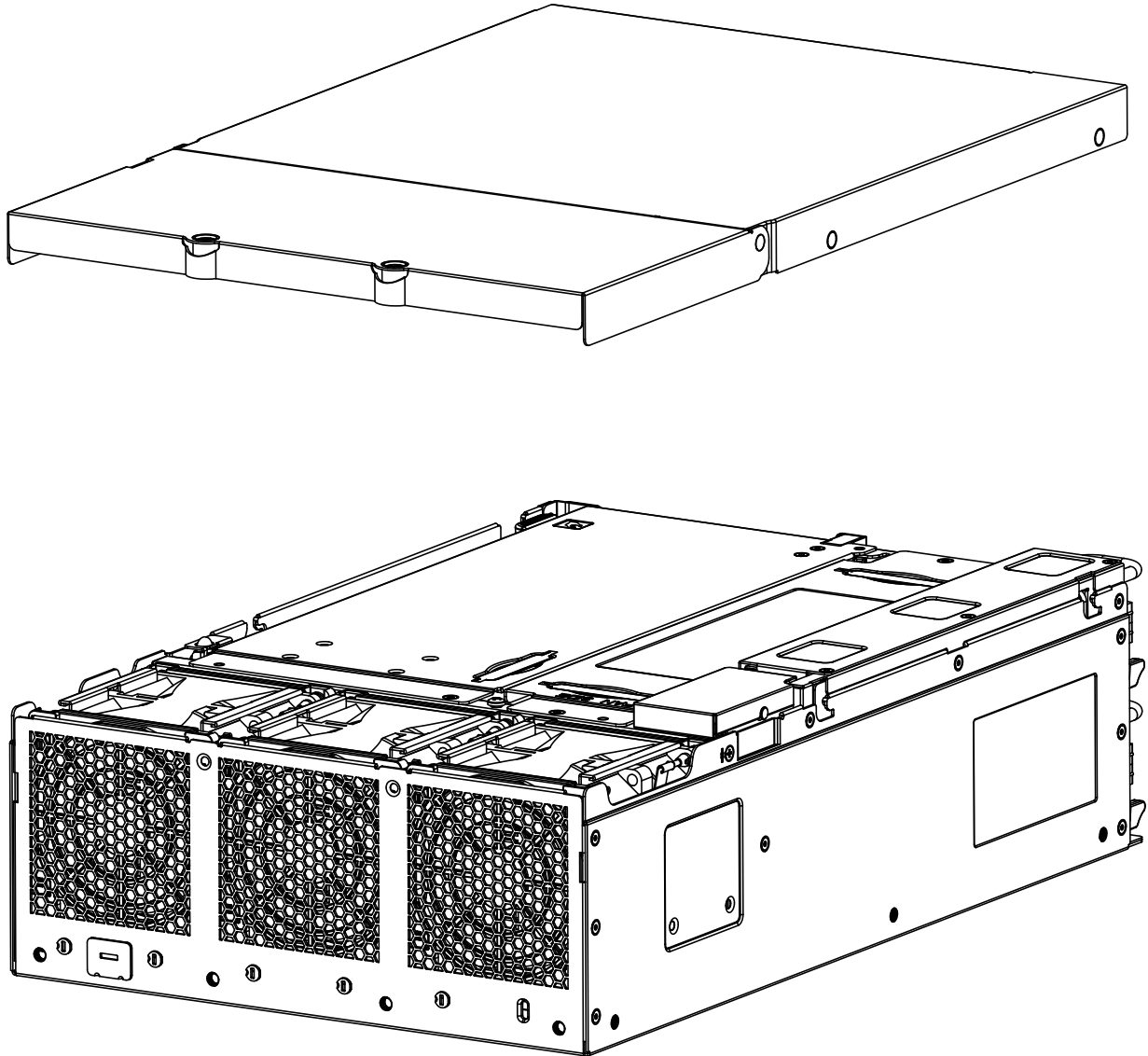

Figure 3-3. Slide Cover Off Chassis

3.3 Replacing Enclosure Fans

The enclosure helps cool the server with three redundant PWM fans, which are hot-swappable for easy replacement. Refer to the following steps to gain access to the fans.

Opening the Fan Cover and Replacing the Fans

1. Remove the two hex screws (#6-32, UNC) as shown below to open the fan cover and let it swing down on its hinges. (System power can remain on.)
2. Unscrew the waterproof fan connector from the failed fan by twisting the fan connector counter-clockwise.
3. Wait for five seconds for the fans to stop rotating then lift the fan housing (which contains two fans) completely out.
4. Insert a new fan housing and push it into its bay until it snaps in, making sure the rubber dampers are in place.
5. Reattach the fan connector paying attention to the keyed notch.
6. Screw in the waterproof fan connector by twisting it clockwise until it stops.
7. Finish by closing the cover at securing with the hex screws.

Caution: To prevent over heating, do not leave the fan cover open for longer than 3 minutes.

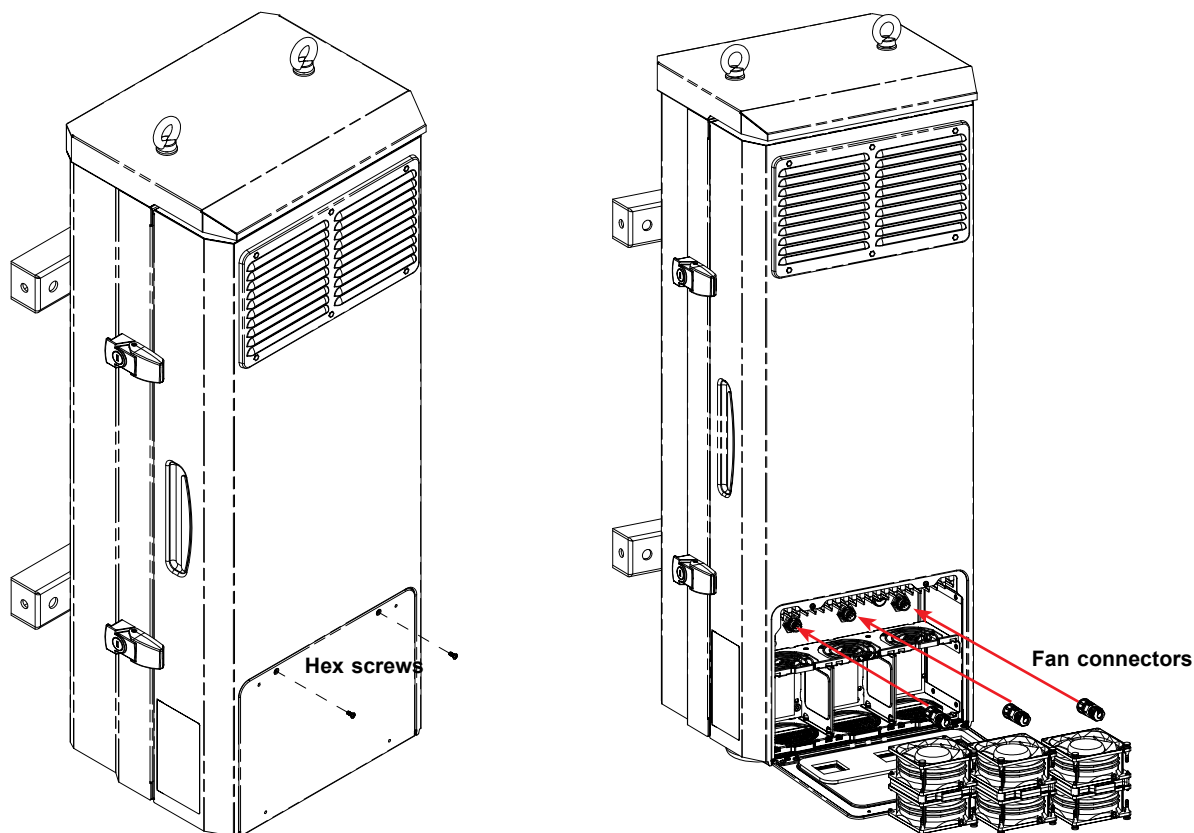

Figure 3-4. Enclosure Fan Installation

3.4 Processor

The E403-9D-16C-IPD2/E403-9D-14CN-IPD2 each features an Intel® Xeon® processor with a range of cores and threads. The E403-9D-16C-IPD2/E403-9D-14CN-IPD2 features between 14 to 16 cores and between 28 to 32 threads with a TDP between 100W to 105W and a three to seven year life cycle. For a full list of the processor details see the tables in Section 1.1.

3.5 Memory Support

The X11SDW-16C-TP13F+/X11SDW-14CN-TP13F+ supports up to 256GB of ECC RDIMM or 512GB of LRDIMM DDR4 memory in four memory slots. Populating these DIMM slots with memory modules of the same type and size will result in interleaved memory, which will improve memory performance.

ESD Precautions

Electrostatic Discharge (ESD) can damage electronic components including memory modules. To avoid damaging your DIMM modules, it is important to handle it very carefully. The following measures are generally sufficient to protect your equipment from ESD.

- Use a grounded wrist strap designed to prevent static discharge.
- Handle the memory module by its edges only.
- Put the memory modules into the antistatic bags when not in use.
- Check the Supermicro website for recommended memory modules.

Memory Population Guidelines

For optimal memory performance, follow the table below when populating memory.

| Memory Population (Balanced) | | | | |
|------------------------------|--------|--------|--------|---------------------|
| DIMMA1 | DIMMB1 | DIMMD1 | DIMME1 | Total System Memory |
| 4GB | 4GB | | | 8GB |
| 4GB | 4GB | 4GB | | 12GB |
| 8GB | 8GB | | | 16GB |
| 4GB | 4GB | 4GB | 4GB | 16GB |
| 8GB | 8GB | 8GB | | 24GB |
| 8GB | 8GB | 8GB | 8GB | 32GB |
| 16GB | 16GB | | | 32GB |
| 16GB | 16GB | 16GB | | 48GB |
| 16GB | 16GB | 16GB | 16GB | 64GB |
| 32GB | 32GB | | | 64GB |
| 32GB | 32GB | 32GB | | 96GB |
| 32GB | 32GB | 32GB | 32GB | 128GB |
| 64GB | 64GB | | | 128GB |
| 64GB | 64GB | 64GB | | 192GB |
| 64GB | 64GB | 64GB | 64GB | 256GB |
| 128GB | 128GB | | | 256GB |
| 128GB | 128GB | 128GB | | 384GB |
| 128GB | 128GB | 128GB | 128GB | 512GB |

DIMM Module Population Sequence

When installing memory modules, the DIMM slots should be populated in the following order: DIMMA1, DIMMB1, DIMMD1, DIMME1.

- Always use DDR4 DIMM modules of the same type and speed.
- Mixed DIMM speeds can be installed. However, all DIMMs will run at the speed of the slowest DIMM.
- The motherboard will support odd-numbered modules (one or three modules installed). However, for best memory performance, install DIMM modules in pairs to activate memory interleaving.

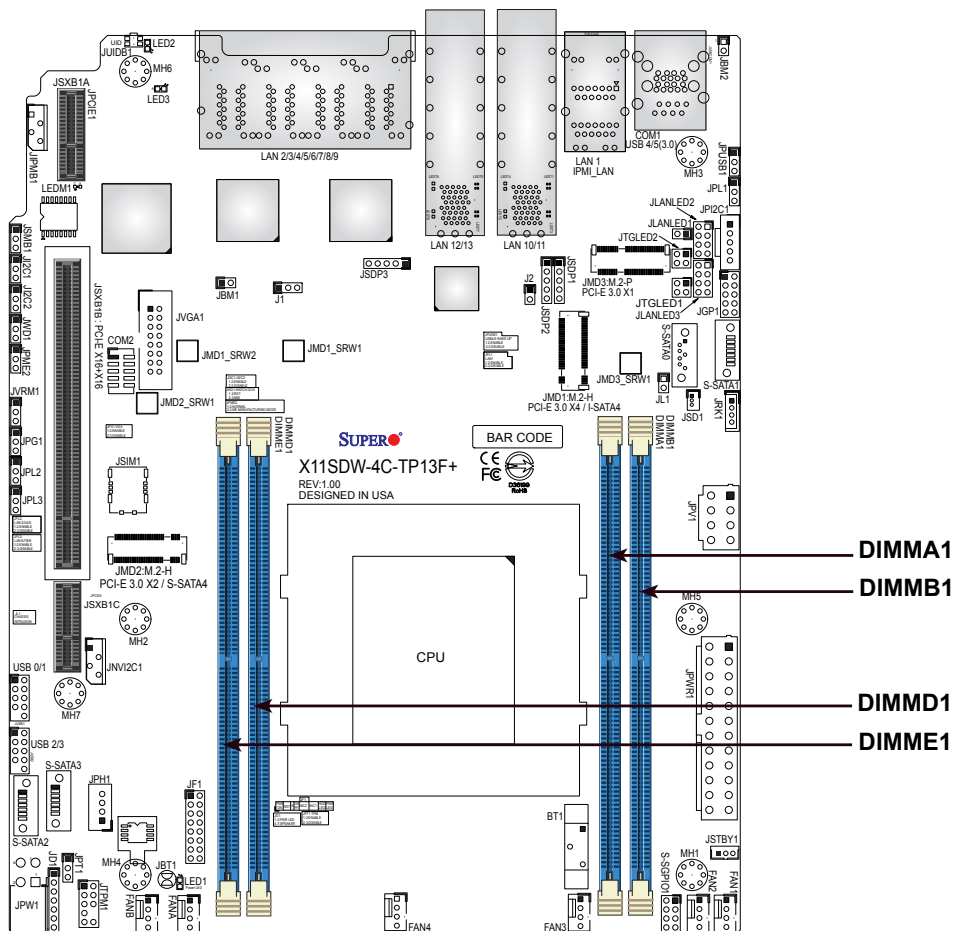

Figure 3-5. DIMM Slots

DIMM Installation

Caution: Exercise extreme caution when installing or removing memory modules to prevent any possible damage to the DIMMs or slots.

Begin by removing power from the system as described in Section 3.1.

1. Decide on the number of DIMMs to install and follow the DIMM population sequence table and diagram on the previous two pages.
2. Push the release tabs outwards on both ends of the DIMM slot to unlock it.

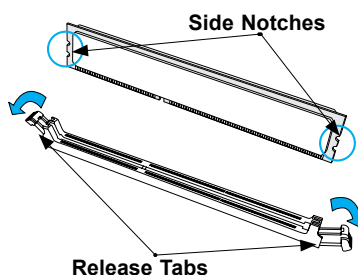

3. Identify the notches on the side and bottom of the DIMM module.

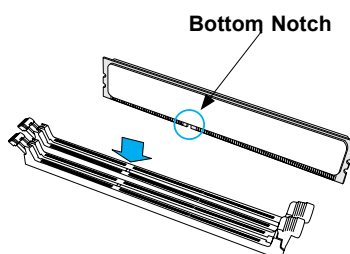

4. Align the bottom notch on DIMM module with the receptive point in the memory slot. Align the side notches with the receptive points on the release tabs.

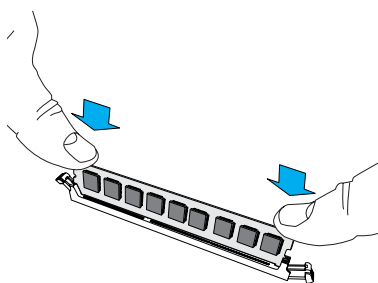

5. With your thumbs on both ends of the DIMM module, press it straight down into the slot until the module snaps into place.
6. Press the release tabs to the locked position to secure the DIMM module into the slot.

DIMM Removal

To remove a DIMM, unlock the release tabs then pull the DIMM from the memory slot.

3.6 M.2 SSD Installation

The X11SDW-16C-TP13F+/X11SDW-14CN-TP13F+ supports three M.2 SSD connectors. To install an M.2 SSD, first locate the connector and the standoff on the motherboard.

1. Remove the screw from the standoff and set aside.
2. Remove the old M.2 SSD drive.
3. Insert a new M.2 SSD into the slot.
4. Align the cutoff circle with the standoff.
5. Reinstall the screw on the standoff.

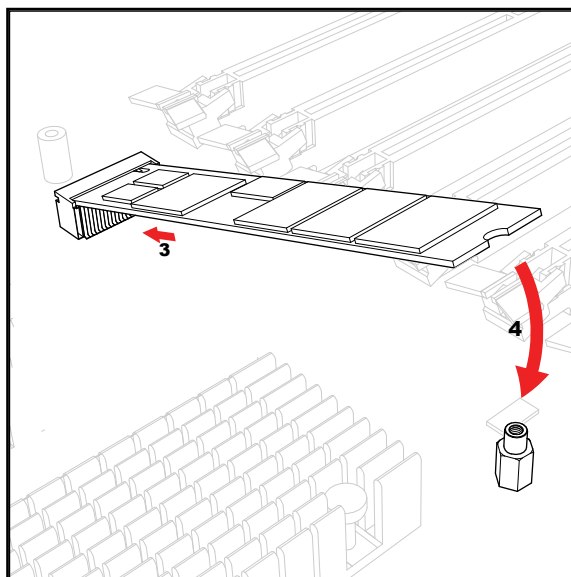

Figure 3-6. Installing an M.2 SSD

Note: The illustration shows the M.2 22110 card. Follow the same procedure to install the M.2 3042 and 2230 cards in their respective slots.

3.7 Motherboard Battery

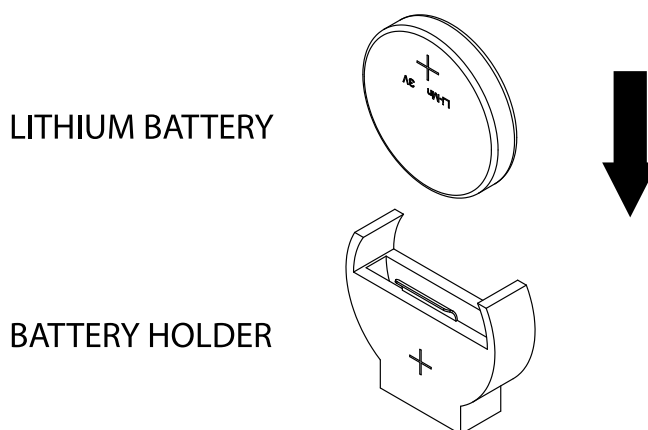

Figure 3-7. Installing the Onboard Battery

This section describes how to remove and install the motherboard battery.

Replacing the Battery

1. Remove power from the system as described in Section 3.1.
2. Push aside the small clamp that covers the edge of the battery. When the battery is released, lift it out of the holder.
3. To insert a new battery, slide one edge under the lip of the holder with the positive (+) side facing up. Then push the other side down until the clamp snaps over it.

Note: Handle used batteries carefully. Do not damage the battery in any way; a damaged battery may release hazardous materials into the environment. Do not discard a used battery in the garbage or a public landfill. Please comply with the regulations of your local hazardous waste management agency to dispose of your used battery properly.

Warning: There is a danger of explosion if the onboard battery is installed upside down (which reverses its polarities). This battery must be replaced only with the same or an equivalent type recommended by the manufacturer (CR2032).

3.8 Installing Storage Drives

The system can accommodate up to four fixed 2.5" storage drives that are installed to a hard drive cage and then inserted into the chassis.

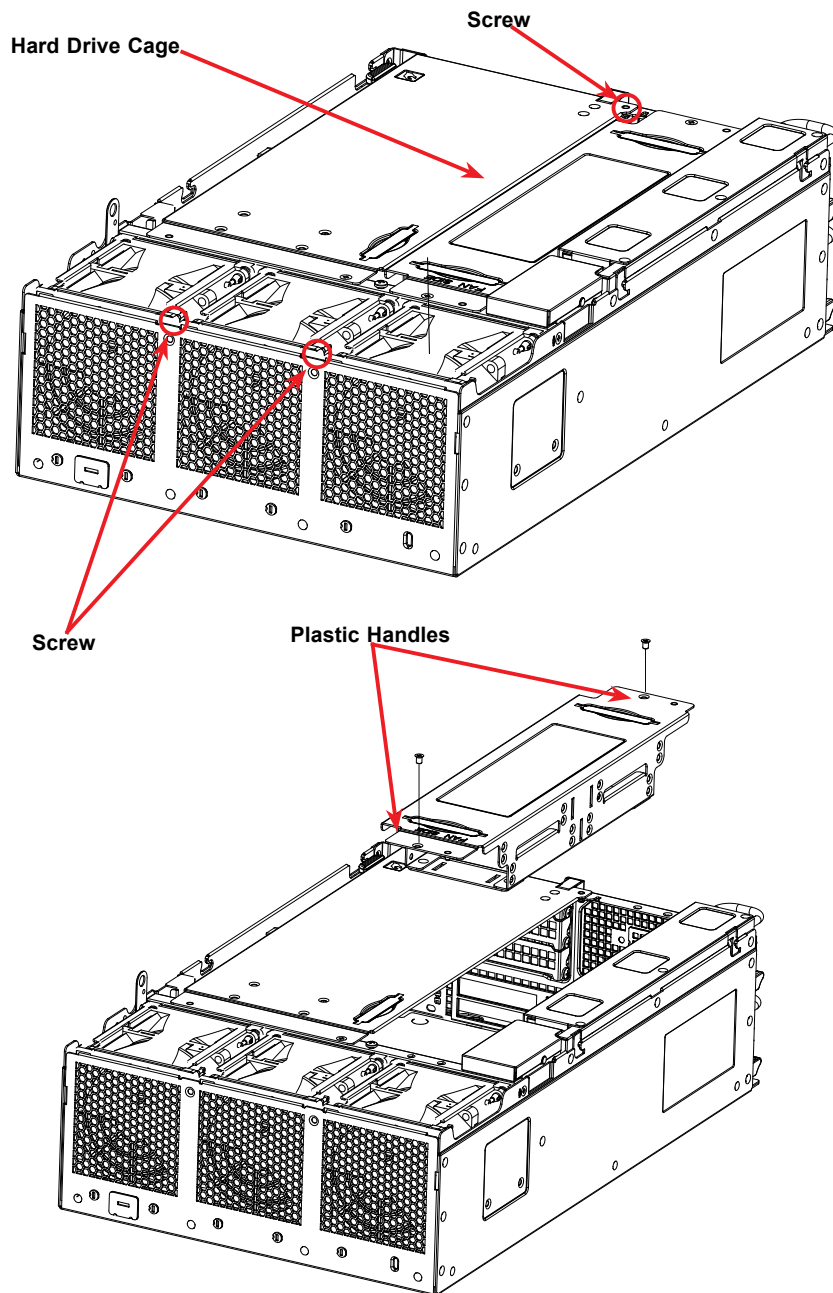

Figure 3-8. Preparing to Install the Hard Drive(s)

Installing Hard Drives

The hard drive cage must be removed from the chassis before installing the hard drives.

1. Make sure there is no power to the system as described in Section 3.1 and remove the chassis cover.
2. See Section 3.2 for instructions on how to remove the top cover.
3. Remove the two screws that are securing the hard drive cage to the chassis, as shown in the previous page.
4. Pull the hard drive cage upwards using the provided plastic handles.

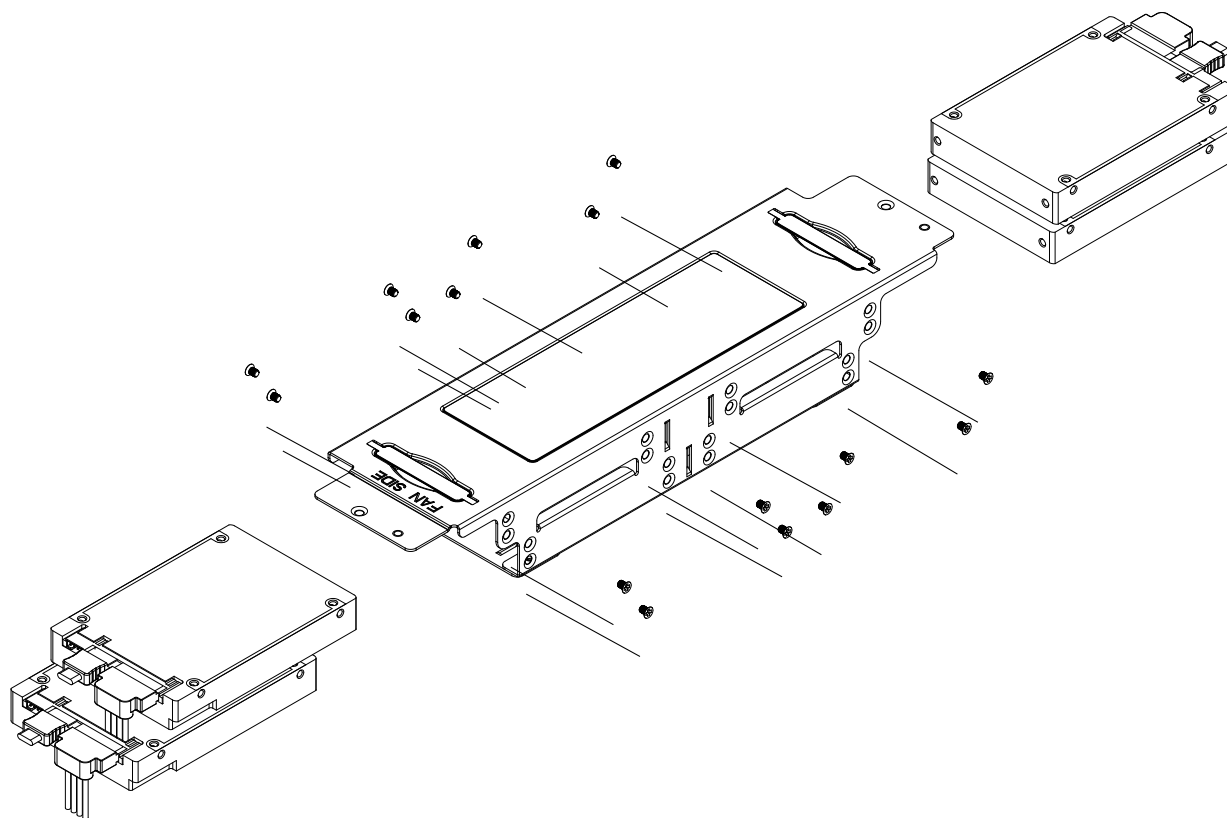

Figure 3-9. Installing 2.5" Hard Drives

5. Place the hard drives inside the hard drive cage, stacked up to two units on each end, then secure them inside the drive bays with the included screws, as shown above.
6. Connect the data and power extension cables to the hard drive.
7. Attach the extension cables to the appropriate motherboard connectors.
8. Secure the hard drive cage back to the chassis with the screws previously set aside.
9. Reinstall the chassis cover and power up the system.

3.9 Expansion Cards

The E403-9D-16C-IPD2/E403-9D-14CN-IPD2 supports up to three PCIe slots on riser cards. Follow the table printed on the riser card to set the JSEL jumper. The I/O configurations may also need to be set in the BIOS.

Installing Expansion Cards

1. Power down the system and remove the AC power cord and the chassis cover.
2. Remove the screw as shown below and set aside.
3. Pull the locking lever up to release the expansion card module.
4. Pull the expansion card module upward with the aid of the plastic handle.
5. Set the jumper on the riser card and install expansion cards.

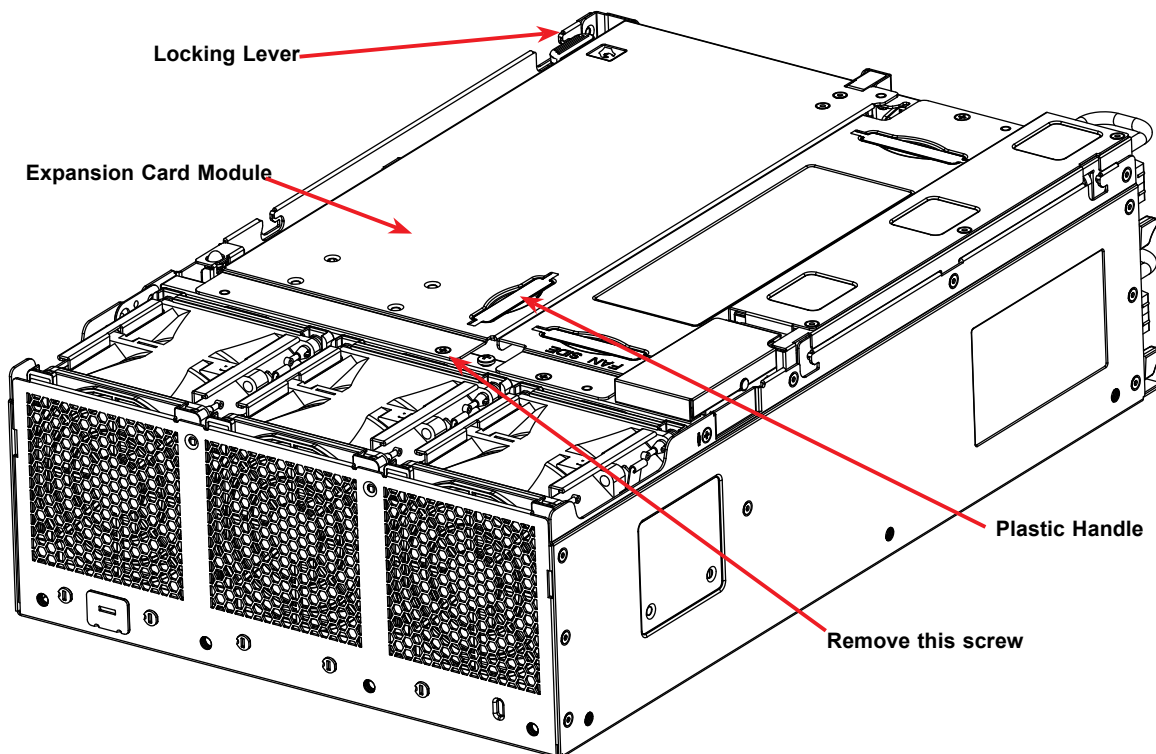

Figure 3-10. Components of the Expansion Card Module

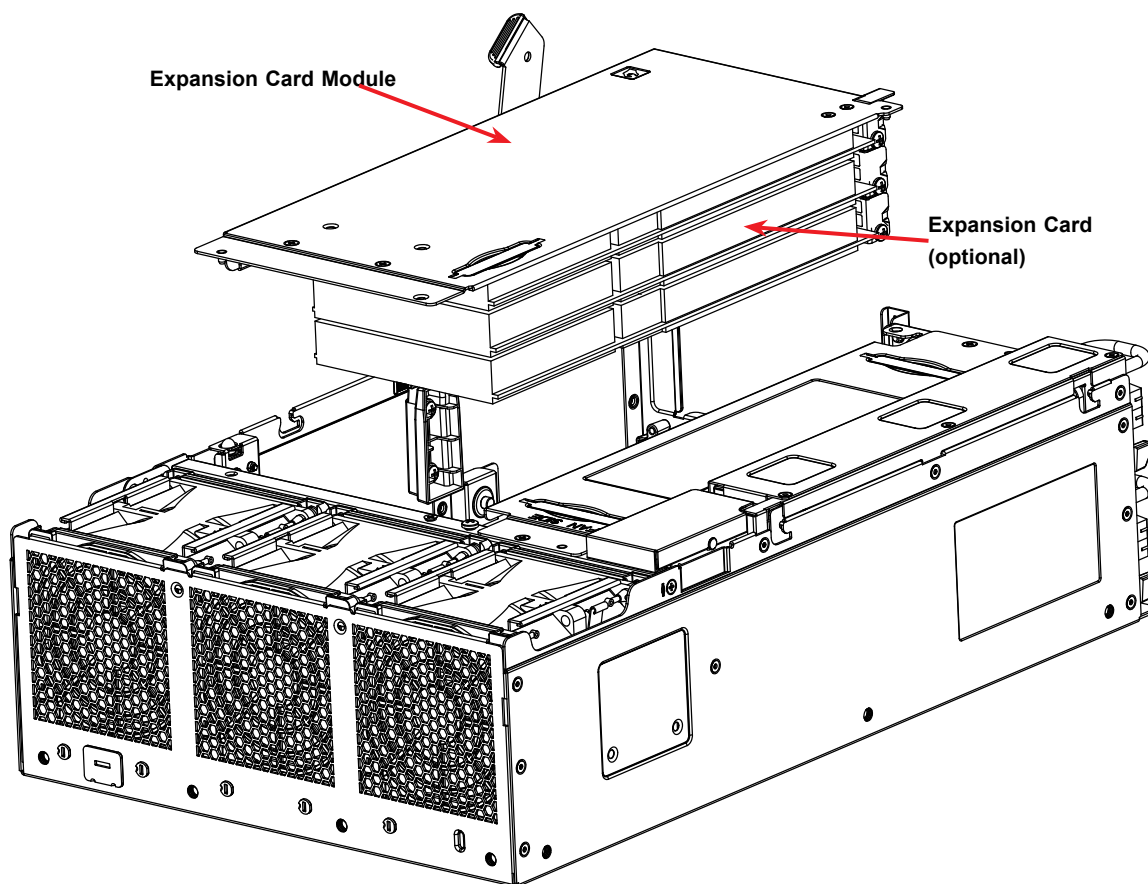

Figure 3-11. Expansion Card Module Removed

6. Connect the power cable to the expansion card if necessary.
7. Reinstall the expansion card module.
8. Reinstall the chassis top cover, reconnect the AC power cord and power up the system.

3.10 Server Cooling

Server Fans

The B403-IP65 includes three hot-swappable 80-mm fans. The figure below demonstrates how to remove a fan. The top cover does not need to be removed for this operation.

Installing or Replacing the Server Fan

1. Access the fans as described in Section 3.2. *Do not remove the server cover.*
2. Press the latch at the side of the fan.
3. Pull up the fan by the two side handles.
4. If replacing a fan, insert the new fan.
5. Close the chassis fan cover and tighten the two thumbscrews.

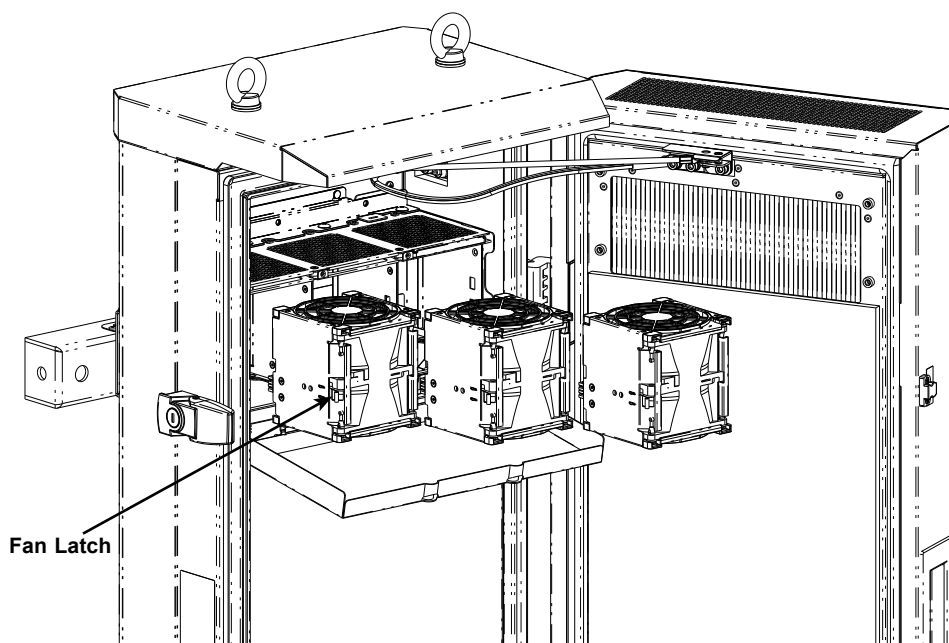

Figure 3-12. Server Fans

Installing the Air Shroud

The air shroud directs airflow from two of the fans to the center of the motherboard.

1. Power down the system and remove the DC power cord and the chassis cover as described in Sections 3.1 and 3.2.
2. Remove the drive bracket and the expansion card module.
3. If you are installing expansion cards that require power from the power supply, you must cut a hole to route the power cable from the power supply to the expansion module.
4. Place the air shroud over the CPU and align the wide-end of the air shroud with the two fans on the power supply side of the chassis.

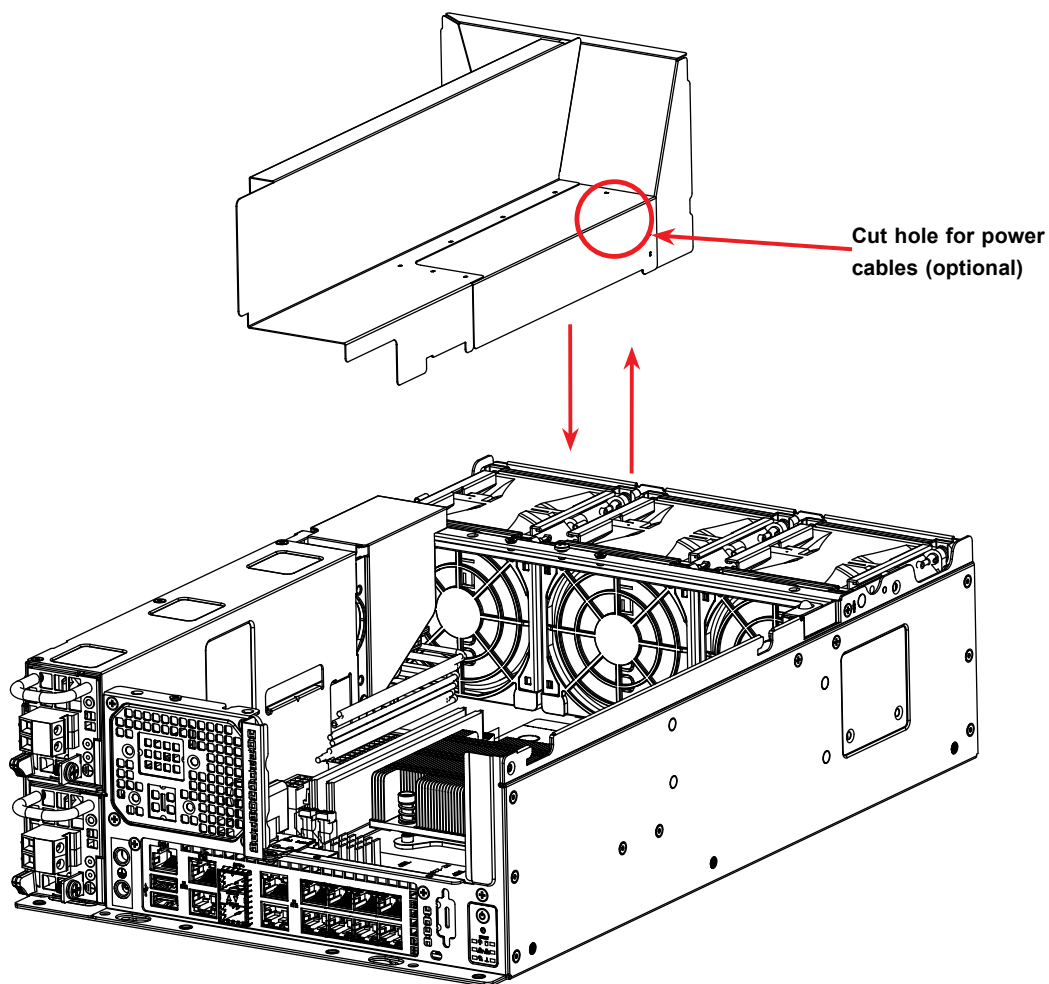

Figure 3-13. Installing the Air Shroud

3.11 Power Supply

The E403-9D-16C-IPD2/E403-9D-14CN-IPD2 includes two 600W DC multi-output PFC power supplies.

Power Supply Failure

If either of the two power supply modules fail, the other module will take the full load and allow the system to continue operation without interruption. The PWR Fail LED will illuminate and remain on until the failed unit has been replaced. Replacement units can be ordered directly from Supermicro (see contact information in the Preface). The hot-swap capability of the power supply modules allows you to replace the failed module without powering down the system.

Replacing the Power Supply

1. Check the LEDs on the power supplies to determine which module has failed.
2. Unplug the power cord from the failed module.
3. Push the release latch (on the back of the power supply) as illustrated, then pull the power supply out using the handle provided.
4. Push the new power supply module into the power bay until you hear a click (replace with the same model: p/n PWS-601D-1R).
5. Reconnect the power cord to the new module.

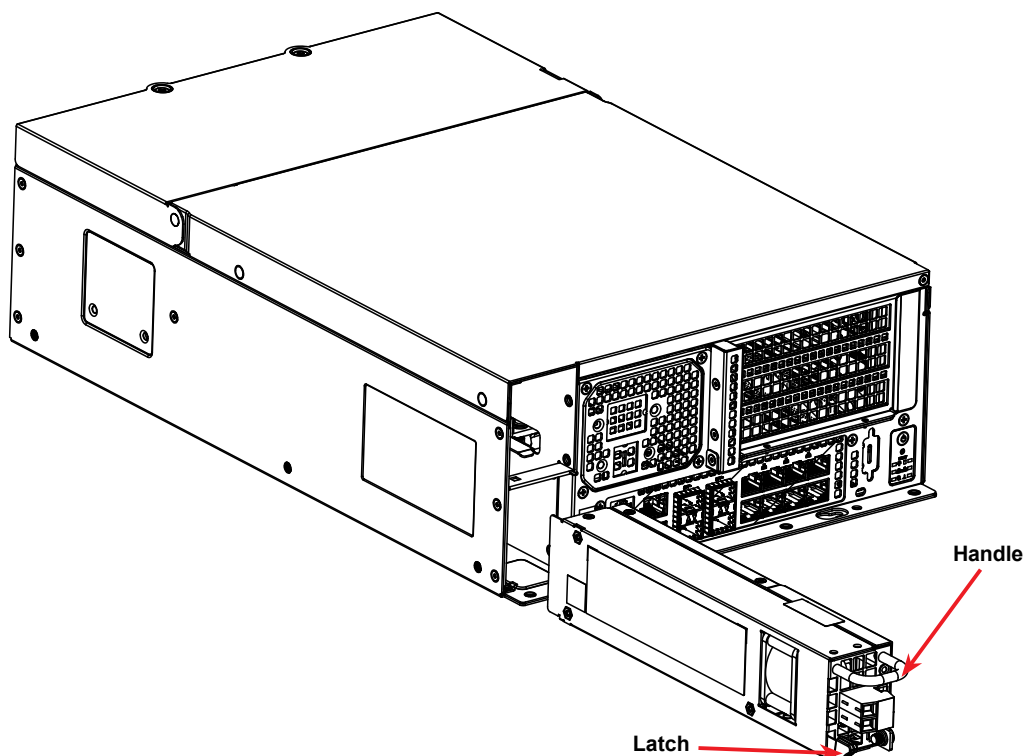

Figure 3-14. Removing the Power Supply

Chapter 4

Motherboard Connections

This section describes the connections on the motherboard and provides pinout definitions. Note that depending on how the system is configured, not all connections are required. The LEDs on the motherboard are also described here.

Please review the Safety Precautions in Appendix B before installing or removing components.

4.1 Motherboard Layout

On the following page is a layout of the X11SDW-4C-TP13F+ motherboard (this same layout also applies to the X11SDW-14CN-TP13F+ and X11SDW-16C-TP13F+) with jumper, connector, and LED locations shown. The table that follows lists their descriptions. Detailed descriptions, pinout information, and jumper settings may also be found later in this chapter.

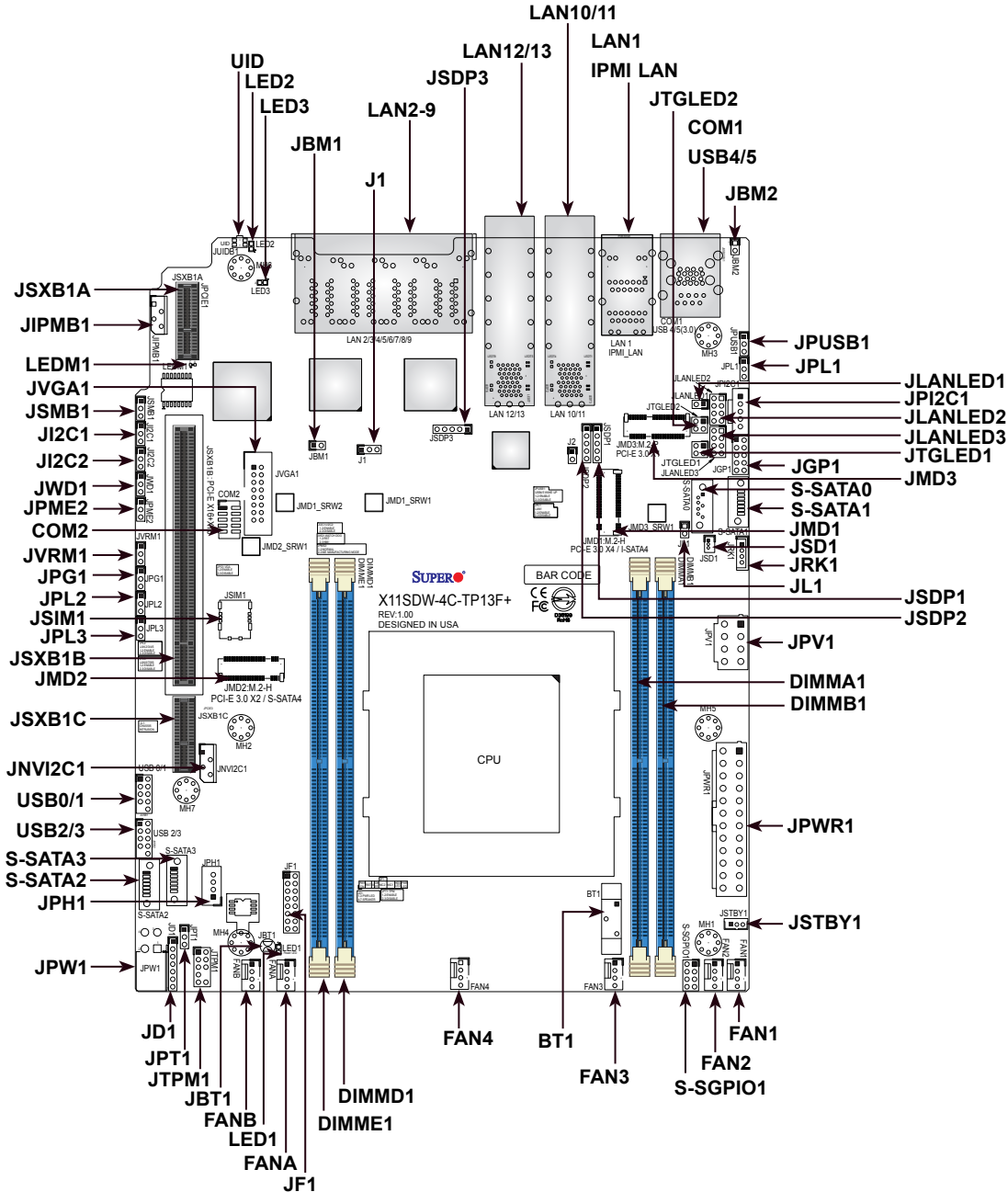

Figure 4-1. Motherboard Layout

Notes:

- "■" indicates the location of pin 1.
- When LED1 (Onboard Power LED indicator) is on, system power is on. Unplug the power cable before installing or removing any components.
- The layout show is for the X11SDW-4C-TP13F+. The X11SDW-16C-TP13F+ and the X11SDW-14CN-TP13F+ share the same layout and features but support different processors (see table on p. 9 for details).

Quick Reference Table

| Jumper | Description | Default Setting |
|---------------------------------------|---|---|
| J1 | M.2 SMBus Enable/Disable | Pins 1-2 (Enabled) |
| JBM1 | IPMI Share LAN Enable/Disable | Open: Enabled (Default) Closed: Disabled |
| JBM2 | IPMI Dedicated/Share LAN Enable/Disable | Open: Enabled (Default) Closed: Disabled |
| JBT1 | CMOS Clear | Open: Normal Closed: Clear CMOS |
| JI ² C1/JI ² C2 | SMB to PCIe Slots Enable/Disable | Pins 2-3 (Disabled) |
| JPG1 | VGA Enable/Disable | Pins 1-2 (Enabled) |
| JPL1 | LAN1 Enable/Disable | Pins 1-2 (Enabled) |
| JPL2 | LAN2/3/4/5 Enable/Disable | Pins 1-2 (Enabled) |
| JPL3 | LAN6/7/8/9 Enable/Disable | Pins 1-2 (Enabled) |
| JPME2 | Manufacturing Mode Select | Pins 1-2 (Normal) |
| JPT1 | TPM Enable/Disable | Pins 1-2 (Enabled) |
| JPUSB1 | USB0/1 Wake up | Pins 1-2 (Enabled) |
| JVRM1 | VRM SMB Data (to BMC or PCH) | Pins 1-2 (BMC) |
| JWD1 | Watch Dog Timer | Pins 1-2 (Reset) |

| LED | Description | Status |
|-------|----------------------------------|--|
| LED1 | Power LED | Solid Green: Power On |
| LED2 | UID LED | Solid Blue: Unit Identified |
| LED3 | Overheat/Power Fail/Fan Fail LED | Solid Red: Overheat Blinking Red: Power Failure/Fan Failure |
| LEDM1 | BMC Heartbeat | Blinking Green: BMC Normal |

| Connector | Description |
|-------------------------|---|
| BT1 | Onboard Battery |
| COM1/COM2 | COM1: Port, COM2: Header |
| FAN1 - FAN4, FANA, FANB | CPU/System Fan Headers |
| IPMI LAN | Dedicated IPMI LAN Port |
| JD1 | Power LED/Speaker Header (Pins 1-3: Power LED, Pins 4-7: Speaker) |
| JF1 | Front Control Panel Header |
| JGP1 | General Purpose I/O Header |
| JIPMB1 | System Management Bus Header (for IPMI only) |
| JL1 | Chassis Intrusion Header |
| JLANLED1 | LAN1 Activity LED Header |
| JLANLED2 | LAN2-5 Activity LED Header |
| JLANLED3 | LAN6-9 Activity LED Header |
| JMD1 | M.2 Slot M-Key 2280/22110 (SATA3.0 / PCIe x4) |

Table continued on next page.

| Connector | Description |
|---------------------|--|
| JMD2 | M.2 Slot B-Key 2242/3042 (USB2.0 / USB3.0 / SATA3.0 / PCIe x2) |
| JMD3 | M.2 Slot E-Key 2230 (USB2.0 / PCIe x1) |
| JNV12C1 | Non-volatile Memory (NVMe) I ² C Header |
| JPH1 | 4-pin HDD Power Connector |
| JPI ² C1 | Power I2C System Management Bus (Power SMB) Header |
| JPV1 | 12V 8-pin DC Power Connector (Required to provide extra power to the CPU, or as alternative power for special enclosure when the 24 pin ATX power is not in use) |
| JPW1 | GPU Power Connector |
| JPWR1 | 24-pin ATX Power Connector |
| JRK1 | Intel RAID Key Header |
| JSD1 | SATA DOM Power Connector |
| JSDP1 | Software-Defined Pins (From X722, LAN 10/11) |
| JSDP2 | Software-Defined Pins (From X722, LAN 12/13) |
| JSDP3 | Software-Defined Pins (From I350 LAN2) |
| JSIM1 | Nano SIM Card Slot |
| JSMB1 | System Management Bus Header |
| JSTBY1 | Standby Power Connector |
| JSXB1A | WIO Connector |
| JSXB1B | WIO Connector |
| JSXB1C | WIO Connector |
| JTGLED1 | LAN10/11 Activity LED Header |
| JTGLED2 | LAN12/13 Activity LED Header |
| JTPM1 | Trusted Platform Module (TPM)/Port 80 Connector |
| JVGA1 | VGA Header |
| JLAN1 | 1G LAN Port (from I210, LAN1) |
| JLAN2 | 10G SFP+ Ports (LAN10/11) |
| JLAN3 | 10G SFP+ Ports (LAN11/12) |
| JLAN4 | 1G LAN Ports (from I350, LAN2-9) |
| S-SATA0 - S-SATA3 | SATA 3.0 Ports |
| S-SGPIO1 | Serial Link General Purpose I/O Header |
| UID | Unit Identifier Switch |
| USB0/1, USB2/3 | Front Accessible USB 2.0 Headers |
| USB4/5 | Back Panel USB 3.0 Ports |

4.2 Power Connections

Power Connectors

The primary ATX power supply connector (JPWR1) meets the ATX SSI EPS 12V specification. JPV1 is the 12V DC power connector that provides power to the motherboard. JPH1 is a 4-pin HDD power connector that provides power to onboard hard disk drives.

| 8-pin 12V Power Pin Definitions | |
|---------------------------------|------------|
| Pin# | Definition |
| 1 - 4 | Ground |
| 5 - 8 | +12V |

| 4-pin HDD Power Pin Definitions | |
|---------------------------------|------------|
| Pin# | Definition |
| 1 | 12V |
| 2-3 | Ground |
| 4 | 5V |

| ATX Power 24-pin Connector Pin Definitions | | | |
|--|------------|------|------------|
| Pin# | Definition | Pin# | Definition |
| 13 | +3.3V | 1 | +3.3V |
| 14 | -12V | 2 | +3.3V |
| 15 | Ground | 3 | Ground |
| 16 | PS_ON | 4 | +5V |
| 17 | Ground | 5 | Ground |
| 18 | Ground | 6 | +5V |
| 19 | Ground | 7 | Ground |
| 20 | Res (NC) | 8 | PWR_OK |
| 21 | +5V | 9 | 5VSB |
| 22 | +5V | 10 | +12V |
| 23 | +5V | 11 | +12V |
| 24 | Ground | 12 | +3.3V |

GPU Power Connector

JPW1 is a GPU power connector. This connector provides additional power for graphic cards

| GPU Power Pin Definitions | |
|---------------------------|------------|
| Pin# | Definition |
| 1 | GND |
| 2 | GND |
| 3 | 12V |
| 4 | 12V |

4.3 Headers and Connectors

Fan Headers

The X11SDW-16C-TP13F+/X11SDW-14CN-TP13F+ has six 4-pin fan headers (FAN1 - FAN4, FANA, FANB). These headers are backwards-compatible with the traditional 3-pin fans. However, fan speed control is available for 4-pin fans only by Thermal Management via the IPMI 2.0 interface. This motherboard supports dual cooling zone. The table below specifies which fan belongs in which zone. Refer to the table below for pin definitions.

| Fan Header Pin Definitions | |
|----------------------------|-----------------|
| Pin# | Definition |
| 1 | Ground (Black) |
| 2 | 2.5A/+12V (Red) |
| 3 | Tachometer |
| 4 | PWM_Control |

| Fan Zone Pin Definitions | | |
|--------------------------|------------|--------|
| Zone | 1 | 2 |
| Fan # | FAN1/2/3/4 | FANA/B |

Power SMB (I²C) Header

The Power System Management Bus (I²C) connector (JPI²C1) monitors the power supply, fan, and system temperatures. Refer to the table below for pin definitions.

| Power SMB Header Pin Definitions | |
|----------------------------------|-------------|
| Pin# | Definition |
| 1 | Clock |
| 2 | Data |
| 3 | PMBUS_Alert |
| 4 | Ground |
| 5 | NC |

Chassis Intrusion

A Chassis Intrusion header is located at JL1 on the motherboard. Attach the appropriate cable from the chassis to inform you of a chassis intrusion when the chassis is opened. Refer to the table below for pin definitions.

| Chassis Intrusion Pin Definitions | |
|-----------------------------------|-----------------|
| Pin# | Definition |
| 1 | Intrusion Input |
| 2 | Ground |

SATA Ports

The X11SDW-16C-TP13F+/X11SDW-14CN-TP13F+ has four S-SATA 3.0 ports. Refer to the tables below for pin definitions. SATA ports provide serial-link signal connections, which are faster than the connections of Parallel ATA.

| SATA 3.0 Port Pin Definitions | |
|-------------------------------|----------|
| Pin# | Signal |
| 1 | Ground |
| 2 | SATA_TXP |
| 3 | SATA_TXN |
| 4 | Ground |
| 5 | SATA_RXN |
| 6 | SATA_RXP |
| 7 | Ground |

M.2 Slot

The X11SDW-16C-TP13F+/X11SDW-14CN-TP13F+ has four M.2 slots. M.2 was formerly known as Next Generation Form Factor (NGFF). M.2 allows for a variety of card sizes, increased functionality, and spatial efficiency. The M.2 slot at JMD1 supports PCIe 3.0 x4 and SATA 3.0 interfaces in a 2280/22110 form factor, whereas the M.2 slot at JMD2 supports PCIe 3.0 x4, SATA 3.0, and USB 3.0 interfaces in a 3042 form factor. The M.2 slot at JMD3 supports PCIe 3.0 x1.

TPM/Port 80 Header

A Trusted Platform Module (TPM)/Port 80 header is located at JTPM1 to provide TPM support and a Port 80 connection. Use this header to enhance system performance and data security. Refer to the table below for pin definitions.

| Trusted Platform Module Header Pin Definitions | | | |
|--|------------|------|------------|
| Pin# | Definition | Pin# | Definition |
| 1 | +3.3V | 2 | SPI_CS# |
| 3 | RESET# | 4 | SPI_MISO |
| 5 | SPI_CLK | 6 | GND |
| 7 | SPI_MOSI | 8 | |
| 9 | +3.3V Stby | 10 | SPI_IRQ# |

VGA Header

Connect a 16-pin VGA extension cable to JVGA1 for a VGA connector.

| VGA Header Pin Definitions | | | |
|-------------------------------|------------|------|---------------|
| Pin# | Definition | Pin# | Definition |
| 1 | VGA_RED | 2 | VGA_GRE |
| 3 | VGA_BLE | 4 | N/C |
| 5 | GND | 6 | VGA_DET (GND) |
| 7 | GND | 8 | GND |
| 9 | 5V | 10 | GND |
| 11 | N/C | 12 | DDCSDA |
| 13 | HSYNC | 14 | VSYNC |
| 15 | DDCSCL | 16 | N/C |

Intel RAID Key Header

The JRK1 header allows the user to enable RAID functions. Refer to the table below for pin definitions.

| Intel RAID Key Pin Definitions | |
|-----------------------------------|---------------|
| Pins | Definition |
| 1 | GND |
| 2 | PU 3.3V Stbby |
| 3 | GND |
| 4 | PCH RAID KEY |

Disk On Module Power Connector

The Disk On Module (DOM) power connector at JSD1 provides 5V power to a solid state DOM storage device connected to one of the SATA ports. Refer to the table below for pin definitions.

| DOM Power Pin Definitions | |
|------------------------------|------------|
| Pin# | Definition |
| 1 | 5V |
| 2 | Ground |
| 3 | Ground |

General Purpose I/O Header

The JGP1 (General Purpose Input/Output) header is a general purpose I/O expander on a pin header via the SMBus. Refer to the table below for pin definitions.

| GPIO Header Pin Definitions | | | |
|--------------------------------|------------|------|------------|
| Pin# | Definition | Pin# | Definition |
| 1 | +3.3V | 2 | GND |
| 3 | GP0 | 4 | GP4 |
| 5 | GP1 | 6 | GP5 |
| 7 | GP2 | 8 | GP6 |
| 9 | GP3 | 10 | GP7 |

S-SGPIO Header

The Serial Link General Purpose Input/Output (S-SGPIO1) header is used to communicate with the enclosure management chip on the back panel.

| SGPIO Header Pin Definitions | | | |
|---------------------------------|------------|------|------------|
| Pin# | Definition | Pin# | Definition |
| 1 | NC | 2 | NC |
| 3 | Ground | 4 | DATA Out |
| 5 | Load | 6 | Ground |
| 7 | Clock | 8 | NC |

Standby Power

The Standby Power header is located at JSTBY1 on the motherboard. Refer to the table below for pin definitions.

| Standby Power Pin Definitions | |
|----------------------------------|---------------|
| Pin# | Definition |
| 1 | +5V Standby |
| 2 | Ground |
| 3 | No Connection |

Power LED/Speaker Header

On the JD1 header, pins 1-3 are for the Power LED and pins 4-7 are for the speaker.

| Speaker Connector Pin Definitions | |
|--------------------------------------|------------|
| Pin Setting | Definition |
| Pins 1-3 | Power LED |
| Pins 4-7 | Speaker |

External I²C Header

The system management bus header is located at JIPMB1. Connect the appropriate cable here to use the IPMB I²C connection on your system. Refer to the table below for pin definitions.

| SMBus Header Pin Definitions | |
|---------------------------------|------------|
| Pin# | Definition |
| 1 | Data |
| 2 | GND |
| 3 | Clock |
| 4 | NC |

NVMe I²C Header

JNVI²C1 is a management header for the Supermicro AOC NVMe PCIe peripheral cards. Connect a corresponding I²C cable to this header. Refer to the table below for pin definitions.

| NVMe I ² C Header Pin Definitions | |
|---|------------|
| Pin# | Definition |
| 1 | PE_HP_SDA |
| 2 | Ground |
| 3 | PE_HP_SCL |
| 4 | PVCCIO |

System Management Bus Header

A System Management Bus header for additional slave devices or sensors is located at JSMB1. See the table below for pin definitions.

| SMBus Header Pin Definitions | |
|---------------------------------|------------|
| Pin# | Definition |
| 1 | Data |
| 2 | Ground |
| 3 | Clock |

Nano SIM Slot

The JSIM1 slot supports a Nano SIM card.

LAN Port Activity LED

JLANLED1 is the activity LED for LAN1, JLANLED2 is the activity LED for LAN2 - LAN5, and JLANLED3 is the activity LED for LAN6 - LAN9.

| JLANLED1 LAN Activity LED Pin Definitions | |
|--|-------------|
| Pin# | Definition |
| 1 | P3V3 Dual |
| 2 | GLAN1_ACT_N |

| JLANLED2 LAN Activity LED Pin Definitions | | | |
|--|------------|------|-------------|
| Pin# | Definition | Pin# | Definition |
| 1 | P3V3 Dual | 2 | LINK0_ACT_N |
| 3 | P3V3 Dual | 4 | LINK1_ACT_N |
| 5 | P3V3 Dual | 6 | LINK2_ACT_N |
| 7 | P3V3 Dual | 8 | LINK3_ACT_N |

| JLANLED3 LAN Activity LED Pin Definitions | | | |
|--|------------|------|-------------|
| Pin# | Definition | Pin# | Definition |
| 1 | P3V3 Dual | 2 | LINK4_ACT_N |
| 3 | P3V3 Dual | 4 | LINK5_ACT_N |
| 5 | P3V3 Dual | 6 | LINK6_ACT_N |
| 7 | P3V3 Dual | 8 | LINK7_ACT_N |

JTGLED1, JTGLED2

JTGLED1 is the activity LED for LAN10 - LAN11, and JTGLED2 is the activity LED for LAN12 - LAN13.

| JTGLED1 LAN Activity LED Pin Definitions | |
|---|--------------|
| Pin# | Definition |
| 1 | P3V3 Dual |
| 2 | 10G_P0_ACT_N |
| 3 | P3V3 Dual |
| 4 | 10G_P1_ACT_N |

| JTGLED2 LAN Activity LED Pin Definitions | |
|---|--------------|
| Pin# | Definition |
| 1 | P3V3 Dual |
| 2 | 10G_P2_ACT_N |
| 3 | P3V3 Dual |
| 4 | 10G_P3_ACT_N |

Software-Defined Pins (SDP)

JSDP1, JSDP2, and JSDP3 are software-defined pins that can be used to support IEEE 1588 auxiliary devices and other hardware or software-control purposes. These pins can be configured to function as standard inputs or General-Purpose Interrupt (GPI) input or output pins. In order for pins to function as GPI, they must be configured as inputs and enabled by the PCH Ethernet or I350.

| JSDP1 Pin Definitions | |
|--------------------------|-------------|
| Pin# | Definition |
| 1 | X722_SDP1_1 |
| 2 | X722_SDP1_0 |
| 3 | X722_SDP0_1 |
| 4 | X722_SDP0_0 |
| 5 | Ground |

| JSDP2 Pin Definitions | |
|--------------------------|------------------|
| Pin# | Definition |
| 1 | 10G_P3_LOW_SPEED |
| 2 | X722_SDP3_0 |
| 3 | 10G_P2_LOW_SPEED |
| 4 | X722_SDP2_0 |
| 5 | Ground |

| JSDP3 Pin Definitions | |
|--------------------------|-------------|
| Pin# | Definition |
| 1 | I350_SDP0_0 |
| 2 | I350_SDP0_1 |
| 3 | I350_SDP0_2 |
| 4 | I350_SDP0_3 |
| 5 | Ground |

4.4 Ports

Rear I/O Ports

See the figure below for the locations and descriptions of the various I/O ports on the front of the motherboard.

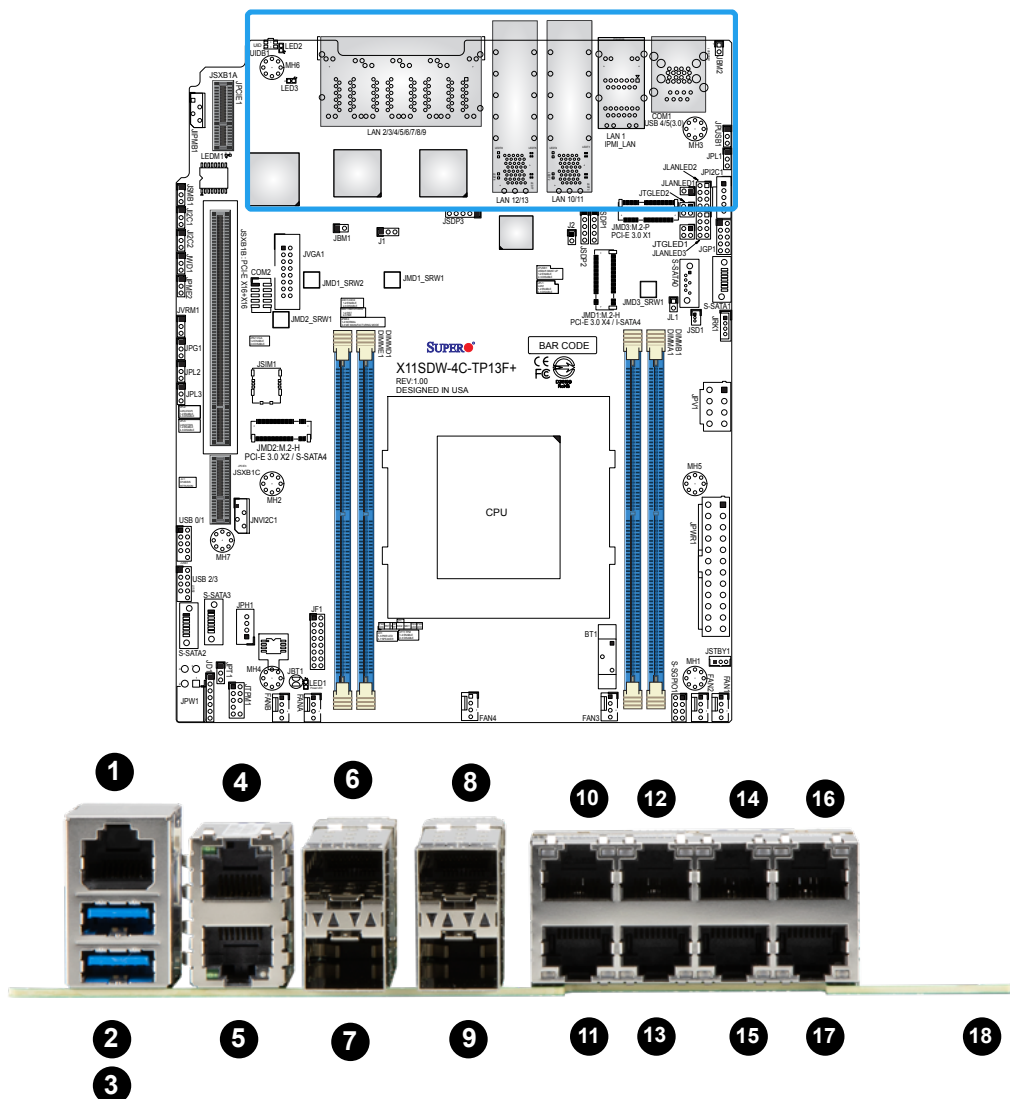

Figure 4-2. Rear I/O Ports

| Rear I/O Port Definitions | | | | | | | |
|---------------------------|---------------|-----|-------------|-----|-------------|-----|-------------|
| # | Description | # | Description | # | Description | # | Description |
| 1. | COM1 | 6. | SFP+ LAN11 | 11. | LAN2 | 16. | LAN9 |
| 2. | USB5 (USB3.0) | 7. | SFP+ LAN10 | 12. | LAN5 | 17. | LAN8 |
| 3. | USB4 (USB3.0) | 8. | SFP+ LAN13 | 13. | LAN4 | 18. | UID Switch |
| 4. | IPMI LAN | 9. | SFP+ LAN12 | 14. | LAN7 | | |
| 5. | LAN1 | 10. | LAN3 | 15. | LAN6 | | |

LAN Ports

The motherboard has 13 LAN ports. LAN1 – LAN9 are 1G ports and LAN10 - LAN13 are 10G SFP+ ports. In addition to the LAN ports, the motherboard offers a dedicated IPMI LAN port. Refer to the table below for the pin definitions.

| LAN Port Pin Definition | | | |
|----------------------------|------------|------|------------|
| Pin# | Definition | Pin# | Definition |
| 1 | TX_D1+ | 5 | BI_D3- |
| 2 | TX_D1- | 6 | RX_D2- |
| 3 | RX_D2+ | 7 | BI_D4+ |
| 4 | BI_D3+ | 8 | BI_D4- |

Warning: The IPMI Ethernet and LAN 1-9 (intra-building ports) of the equipment or subassembly are suitable for connection to intra-building or unexposed wiring or cabling only. The intra-building ports of the equipment or subassembly **MUST NOT** be metallically connected to interfaces that connect to the OSP or its wiring. These interfaces are designed for use as intra-building interfaces only (Type 4 or 4a ports as described in GR-1089-CORE) and require isolation from the exposed OSP cabling. The addition of Primary Protectors is not sufficient protection in order to connect these interfaces metallically to OSP wiring.

COM Port/Header

The motherboard has one COM port on the I/O front panel and one COM header on the motherboard to provide serial connections.

| COM Port Pin Definitions | | | |
|-----------------------------|------------|------|------------|
| Pin# | Definition | Pin# | Definition |
| 1 | SP_DCDA | 2 | SP_DSRA |
| 3 | SP_RXDA | 4 | SP_RTSA |
| 5 | SP_TXDA | 6 | SP_STSA |
| 7 | SP_DTRA | 8 | SP_RIA |
| 9 | GND | 10 | NC |

| RJ45 Port Pin Definitions | | | |
|------------------------------|------------|------|------------|
| Pin# | Definition | Pin# | Definition |
| 1 | RTS | 6 | RXD |
| 2 | DTR | 7 | DSR |
| 3 | TXD | 8 | CTS |
| 4 | GND | | |
| 5 | GND | | |

Universal Serial Bus (USB) Ports

The motherboard has two USB 3.0 Gen 1 ports (USB4/5) on the I/O back panel. There are two USB 2.0 headers (USB0/1, USB2/3). These onboard headers can be used to provide front side USB access with a cable (not included).

| USB4/5 (USB 3.0 Type-A) Pin Definitions | | | |
|--|------------|------|------------|
| Pin# | Definition | Pin# | Definition |
| 1 | VBUS | 5 | SSRX- |
| 2 | USB_N | 6 | SSRX+ |
| 3 | USB_P | 7 | GND |
| 4 | GND | 8 | SSTX- |
| | | 9 | SSTX+ |

| Front Panel USB 2.0 Header Pin Definitions | | | |
|---|------------|------|------------|
| Pin# | Definition | Pin# | Definition |
| 1 | +5V | 2 | +5V |
| 3 | USB_PN2 | 4 | USB_PN3 |
| 5 | USB_PP2 | 6 | USB_PP3 |
| 7 | Ground | 8 | Ground |
| 9 | Key | 10 | NC |

Unit Identifier Button/UID LED Indicator

A Unit Identifier (UID) LED is located on the motherboard. The UID LED provides easy identification of a system unit that may be in need of service.

Note: UID can also be triggered via IPMI on the motherboard. For more information on IPMI, please refer to the IPMI User's Guide posted on our website at <http://www.supermicro.com>

| UID LED Pin Definitions | |
|----------------------------|-----------------|
| Color | Status |
| Blue: On | Unit Identified |

| UID Button Pin Definitions | |
|-------------------------------|------------|
| Pin# | Definition |
| 1 | Ground |
| 2 | Ground |
| 3 | Button In |
| 4 | Button In |

Front Control Panel

JF1 contains header pins for various buttons and indicators that are normally located on a control panel at the front of the chassis. These connectors are designed specifically for use with Supermicro chassis. See the figure below for the descriptions of the front control panel buttons and LED indicators.

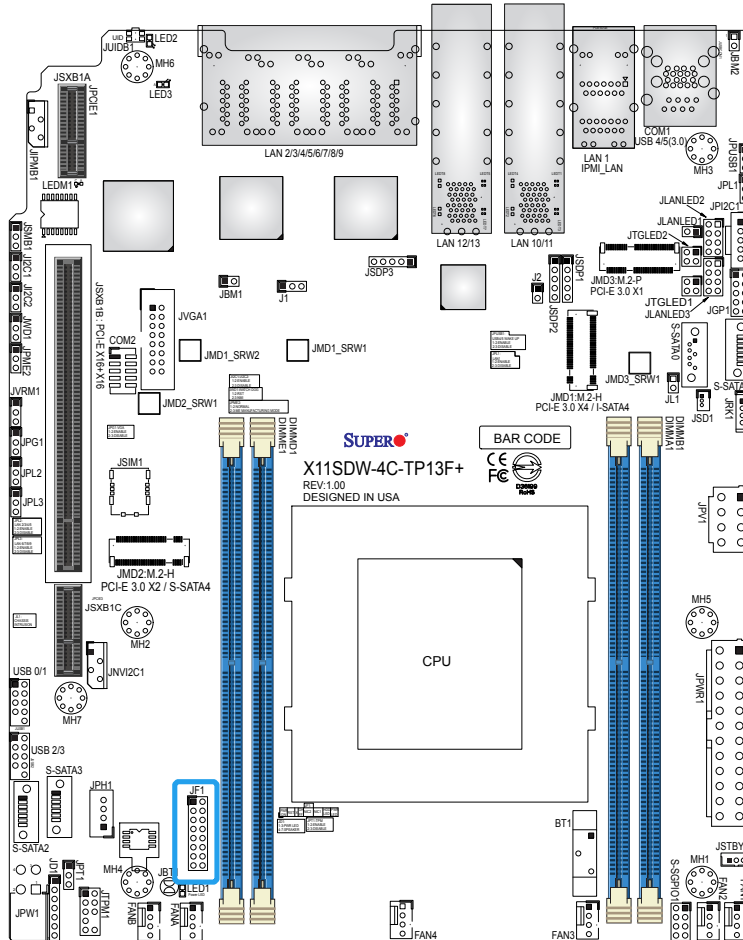

| | 1 | 2 | |
|-----------------------------|---|---|-------------------|
| PWR } Power Button | ○ | ○ | Ground |
| Reset } Reset Button | ○ | ○ | Ground |
| 3.3V | ○ | ○ | Power Fail LED |
| UID | ○ | ○ | OH/Fan Fail |
| 3.3V Stby | ○ | ○ | NIC2 Activity LED |
| 3.3V Stby | ○ | ○ | NIC1 Activity LED |
| 3.3V Stby | ○ | ○ | HDD LED |
| 3.3V | ○ | ○ | PWR LED |

15 16

Figure 4-3. JF1 Header Definitions

Power Button

The Power Button connection is located on pins 1 and 2 of JF1. Momentarily contacting both pins will power on/off the system. This button can also be configured to function as a suspend button (with a setting in the BIOS - see Chapter 6). To turn off the power in the suspend mode, press the button for at least four seconds. Refer to the table below for pin definitions.

| Power Button Pin Definitions (JF1) | |
|---------------------------------------|------------|
| Pins | Definition |
| 1 | Signal |
| 2 | Ground |

Reset Button

The Reset Button connection is located on pins 3 and 4 of JF1. Attach it to a hardware reset switch on the computer case to reset the system. Refer to the table below for pin definitions.

| Reset Button Pin Definitions (JF1) | |
|---------------------------------------|------------|
| Pins | Definition |
| 3 | Reset |
| 4 | Ground |

Power Fail LED

The Power Fail LED connection is located on pins 5 and 6 of JF1. Refer to the table below for pin definitions.

| Power Fail LED Pin Definitions (JF1) | |
|---|------------|
| Pin# | Definition |
| 5 | +3.3V |
| 6 | PWR LED |

Overheat (OH)/Fan Fail

Connect an LED cable to OH/Fan Fail connections on pins 7 and 8 of JF1 to provide warnings for chassis overheat and fan failure. Refer to the table below for pin definitions.

| OH/Fan Fail Indicator Status | |
|------------------------------|------------|
| State | Definition |
| Off | Normal |
| On | Overheat |
| Flashing | Fan Fail |

| OH/Fan Fail LED Pin Definitions (JF1) | |
|---------------------------------------|-----------------|
| Pin# | Definition |
| 7 | +3.3V |
| 8 | OH/Fan Fail LED |

NIC1/NIC2 (LAN1/LAN2)

The NIC (Network Interface Controller) LED connection for LAN port 1 is located on pins 11 and 12 of JF1, and the LED connection for LAN Port 2 is on pins 9 and 10. Attach NIC LED cables to NIC1 and NIC2 LED indicators to display network activities. Refer to the table below for pin definitions.

| LAN1/LAN2 LED Pin Definitions (JF1) | |
|-------------------------------------|------------------|
| Pin# | Definition |
| 9/11 | 3.3V Standby |
| 10/12 | NIC Activity LED |

HDD LED

The HDD LED connection is located on pins 13 and 14 of JF1. Attach a cable here to show hard drive activity status. Refer to the table below for pin definitions.

| HDD LED Pin Definitions (JF1) | |
|-------------------------------|-------------|
| Pins | Definition |
| 13 | +3.3V Stdby |
| 14 | HDD Active |

Power LED

The Power LED connection is located on pins 15 and 16 of JF1. Refer to the table below for pin definitions.

| Power LED Pin Definitions (JF1) | |
|---------------------------------|------------|
| Pins | Definition |
| 15 | +3.3V |
| 16 | PWR LED |

4.5 Jumpers

Explanation of Jumpers

To modify the operation of the motherboard, jumpers are used to choose between optional settings. Jumpers create shorts between two pins to change the function associated with it. Pin 1 is identified with a square solder pad on the printed circuit board. See the motherboard layout page for jumper locations.

Note: On a two-pin jumper, "Closed" means the jumper is on both pins and "Open" indicates the jumper is either on only one pin or has been completely removed.

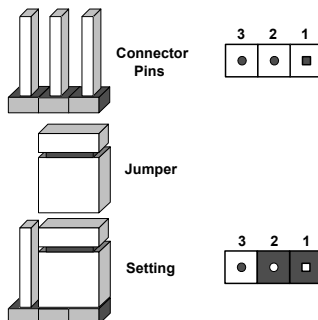

CMOS Clear

JBT1 is used to clear CMOS, which will also clear any passwords. Instead of pins, this jumper consists of contact pads to prevent accidentally clearing the contents of CMOS.

To Clear CMOS

1. First power down the system and unplug the power cords.
2. Remove the cover of the chassis to access the motherboard.
3. Remove the onboard battery from the motherboard.
4. Short the CMOS pads with a metal object such as a small screwdriver for at least four seconds.
5. Remove the screwdriver (or shorting device).
6. Replace the cover, reconnect the power cord(s) and power on the system.

Note: Clearing CMOS will also clear all passwords.

Do not use the PW_ON connector to clear CMOS.



SMBus to PCIe Slots

Jumpers JI2C1 and JI2C2 allow you to connect the System Management Bus (I2C) to the PCIe slots. Both jumpers must be set to the same setting (JI2C1 controls the clock and JI2C2 controls the data).

| SMBus to PCIe Slots Jumper Settings | |
|--|--------------------|
| Jumper Setting | Definition |
| Pins 1-2 | Enabled |
| Pins 2-3 | Disabled (Default) |

Manufacturing Mode Select

Close pins 2-3 of jumper JPME2 to bypass SPI flash security and force the system to operate in the manufacturing mode, which will allow the user to flash the system firmware from a host server for system setting modifications. Refer to the table below for jumper settings.

| Manufacturing Mode Select Jumper Settings | |
|--|--------------------|
| Jumper Setting | Definition |
| Pins 1-2 | Normal (Default) |
| Pins 2-3 | Manufacturing Mode |

VGA Enable/Disable

JPG1 allows you to enable or disable the VGA port using the onboard graphics controller. The default setting is Enabled.

| VGA Enable/Disable Jumper Settings | |
|---------------------------------------|------------|
| Jumper Setting | Definition |
| Pins 1-2 | Enabled |
| Pins 2-3 | Disabled |

I²C Bus for VRM

JVRM1 allows the BMC or the PCH to access CPU and memory VRM controllers. Refer to the table below for jumper settings.

| VRM Jumper Settings | |
|------------------------|--------------|
| Jumper Setting | Definition |
| Pins 1-2 | BMC (Normal) |
| Pins 2-3 | PCH |

Watch Dog

JJWD1 controls the Watch Dog function. Watch Dog is a monitor that can reboot the system when a software application hangs. Jumping pins 1-2 will cause Watch Dog to reset the system if an application hangs. Jumping pins 2-3 will generate a non-maskable interrupt signal for the application that hangs. Watch Dog must also be enabled in BIOS.

Note: When Watch Dog is enabled, users need to write their own application software to disable it

| Watch Dog Jumper Settings | |
|---------------------------|------------|
| Jumper Setting | Definition |
| Pins 1-2 | Reset |
| Pins 2-3 | NMI |
| Open | Disabled |

LAN Port Enable/Disable

Change the setting of jumpers JPL1 for LAN1, JPL2 for LAN2 - LAN5, and JPL3 for LAN6 - LAN9 to enable or disable the LAN ports.

| LAN Port Enable/Disable Jumper Settings | |
|---|------------|
| Jumper Setting | Definition |
| Pins 1-2 | Enabled |
| Pins 2-3 | Disabled |

TPM Enable

Use JPT1 to enable or disable support for the TPM module. Refer to the table below for jumper settings.

| TPM Enable/Disable Jumper Settings | |
|------------------------------------|-------------------|
| Jumper Setting | Definition |
| Pins 1-2 | Enabled (Default) |
| Pins 2-3 | Disabled |

M.2 SMBus Enable

Use J1 to enable or disable the M.2 SMBus. Refer to the table below for jumper settings.

| M.2 SMBus Enable/Disable Jumper Settings | |
|--|-------------------|
| Jumper Setting | Definition |
| Pins 1-2 | Enabled (Default) |
| Pins 2-3 | Disabled |

IPMI Share LAN Enable/Disable

Set the JBM1 jumper to enabled to share i210 LAN with IPMI.

| IPMI Share LAN Enable/Disable Jumper Settings | |
|---|-------------------|
| Jumper Setting | Definition |
| Pins 1-2 (Open) | Enabled (Default) |
| Pins 1-2 (Short) | Disabled |

IPMI Dedicated/Share LAN Enable/Disable

Use JBM2 to enable or disable the dedicated IPMI LAN port. Refer to the table below for jumper settings.

| IPMI Dedicated/Share LAN Enable/Disable Jumper Settings | |
|---|-------------------|
| Jumper Setting | Definition |
| Pins 1-2 (Open) | Enabled (Default) |
| Pins 1-2 (Short) | Disabled |

USB Wake Up

Use the JPU1 jumper to enable system wake up via a USB device. This jumper allows you to wake up the system by pressing a key on the USB keyboard or by clicking the USB mouse of your system. The JPU1 jumper is used together with the USB Wake Up function in the BIOS. Enable both the jumper and the BIOS setting to activate this function. When the USB Wake Up function is enabled, it will be active on all USB ports. Refer to the table below for jumper settings.

| USB Wake Up Jumper Settings | |
|-----------------------------|-------------------|
| Jumper Setting | Definition |
| Pins 1-2 | Enabled (Default) |
| Pins 2-3 | Disabled |

4.6 LED Indicators

LAN LEDs

Thirteen LAN ports (LAN1 - LAN13) are located on the I/O back panel. Each LAN port has two LEDs. The yellow LED indicates activity, while the other Link LED may be green, amber, or off to indicate the speed of the connection. Refer to the tables below for more information.

| LAN Activity LEDs (Left) LED State | | |
|---------------------------------------|----------|------------|
| Color | Status | Definition |
| Yellow | Flashing | Active |

| LAN Link LEDs (Right) LED State | |
|------------------------------------|---------------|
| LED Color | Definition |
| Off | No Connection |
| Amber | 1 Gbps |
| Green | 10 Gbps |

Power LED

LED1 is an Onboard Power LED. When this LED is lit, it means power is present on the motherboard. In suspend mode, this LED will blink on and off. Be sure to turn off the system and unplug the power cord(s) before removing or installing components.

| Onboard Power LED Indicator | |
|-----------------------------|---|
| LED Color | Definition |
| Off | System Off (power cable not connected) |
| Green | System On |

BMC Heartbeat LED

LEDM1 is the BMC heartbeat LED. When the LED is blinking green, BMC is working. Refer to the table below for the LED status.

| BMC Hearbeat LED Indicator | |
|----------------------------|------------|
| LED Color | Definition |
| Green: Blinking | BMC Normal |

Overheat/Power Fail/Fan Fail LED

When the light for LED3 is solid red, it means overheating. When the LED is blinking red, it means a power failure or fan failure.

| Overheat/Power Fail/Fan Fail LED Indicator | |
|--|-------------------------------|
| LED Color | Definition |
| Solid Red | Overheat |
| Blinking Red | Power Failure/ Fan Failure |

Chapter 5

Software

This chapter describes the available software for the system.

5.1 Driver Installation

The Supermicro website contains drivers and utilities for your system at <https://www.supermicro.com/wdl>. Some of these must be installed, such as the chipset driver.

After accessing the website, go into the CDR_Images directory and locate the ISO file for your motherboard. Download this file to create a DVD of the drivers and utilities it contains. (You may also use a utility to extract the ISO file if preferred.)

Another option is to go to the Supermicro website at <http://www.supermicro.com/products/>. Find the product page for your motherboard here, where you may download individual drivers and utilities to your hard drive or a USB flash drive and install from there.

Note: To install the Windows OS, please refer to the instructions posted on our website at <http://www.supermicro.com/support/manuals/>.

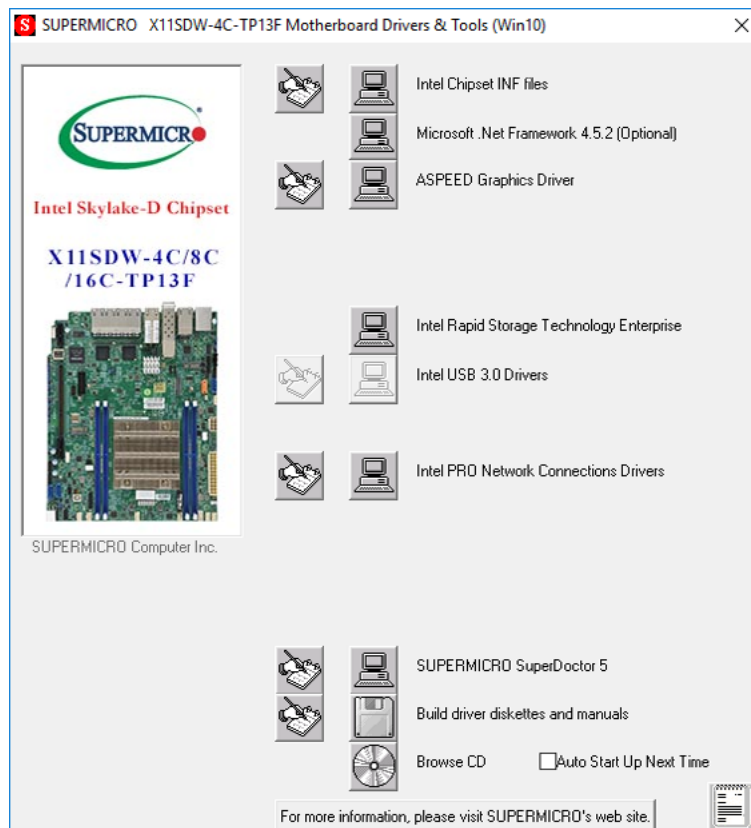

Figure 5-1. Driver & Tool Installation Screen

Note: Click the icons showing a hand writing on paper to view the readme files for each item. Click the computer icons to the right of these items (from top to the bottom) one at a time. **After installing each item, you must re-boot the system before moving on to the next item on the list.** The bottom icon with a CD on it allows you to view the entire contents.

5.2 SuperDoctor® 5

The Supermicro SuperDoctor 5 is a program that functions in a command-line or web-based interface for Windows and Linux operating systems. The program monitors such system health information as CPU temperature, system voltages, system power consumption, fan speed, and provides alerts via email or Simple Network Management Protocol (SNMP).

SuperDoctor 5 comes in local and remote management versions and can be used with Nagios to maximize your system monitoring needs. With SuperDoctor 5 Management Server (SSM Server), you can remotely control power on/off and reset chassis intrusion for multiple systems with SuperDoctor 5 or IPMI. SuperDoctor 5 Management Server monitors HTTP, FTP, and SMTP services to optimize the efficiency of your operation.

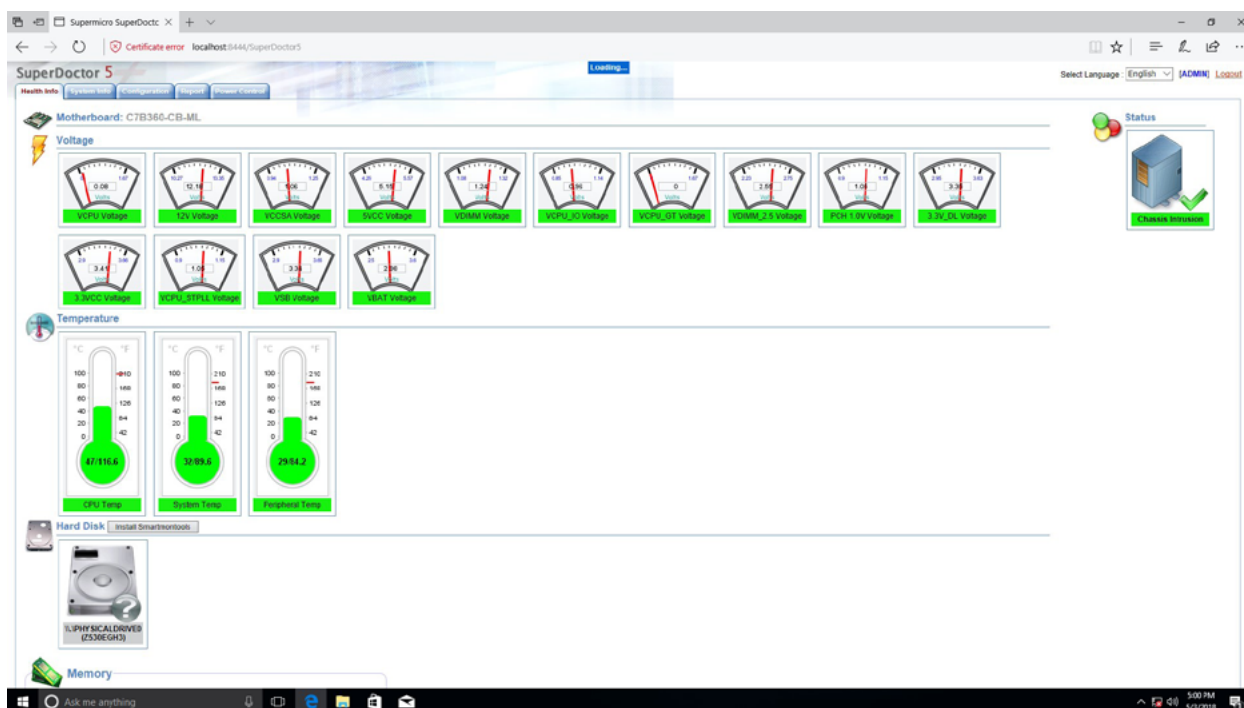

Figure 5-2. SuperDoctor 5 Interface Display Screen (Health Information)

5.3 IPMI

The X11SDW-16C-TP13F+/X11SDW-14CN-TP13F+ motherboard supports the Intelligent Platform Management Interface (IPMI). IPMI is used to provide remote access, monitoring and management. There are several BIOS settings that are related to IPMI.

Supermicro ships standard products with a unique password for the BMC ADMIN user. This password can be found on a label on the motherboard.

For general documentation and information on IPMI, please visit our website at: <http://www.supermicro.com/products/nfo/IPMI.cfm>.

Chapter 6

UEFI BIOS

6.1 Introduction

This chapter describes the AMIBIOS™ Setup utility for the X11SDW-16C-TP13F+/X11SDW-14CN-TP13F+ motherboard. The BIOS is stored on a chip and can be easily upgraded using a flash program.

Note: Due to periodic changes to the BIOS, some settings may have been added or deleted and might not yet be recorded in this manual. Please refer to the Manual Download area of our website for any changes to the BIOS that may not be reflected in this manual.

Starting the Setup Utility

To enter the BIOS Setup Utility, hit the <Delete> key while the system is booting-up. (In most cases, the <Delete> key is used to invoke the BIOS setup screen. There are a few cases when other keys are used, such as <F1>, <F2>, etc.) Each main BIOS menu option is described in this manual.

The Main BIOS screen has two main frames. The left frame displays all the options that can be configured. "Grayed-out" options cannot be configured. The right frame displays the key legend. Above the key legend is an area reserved for a text message. When an option is selected in the left frame, it is highlighted in white. Often a text message will accompany it. (Note that BIOS has default text messages built in. We retain the option to include, omit, or change any of these text messages.) Settings printed in **Bold** are the default values.

A " ►" indicates a submenu. Highlighting such an item and pressing the <Enter> key will open the list of settings within that submenu.

The BIOS setup utility uses a key-based navigation system called hot keys. Most of these hot keys (<F1>, <Enter>, <ESC>, <Arrow> keys, etc.) can be used at any time during the setup navigation process.

6.2 Main Setup

When you first enter the AMI BIOS setup utility, you will enter the Main setup screen. You can always return to the Main setup screen by selecting the Main tab on the top of the screen. The Main BIOS setup screen is shown below and the following features will be displayed:

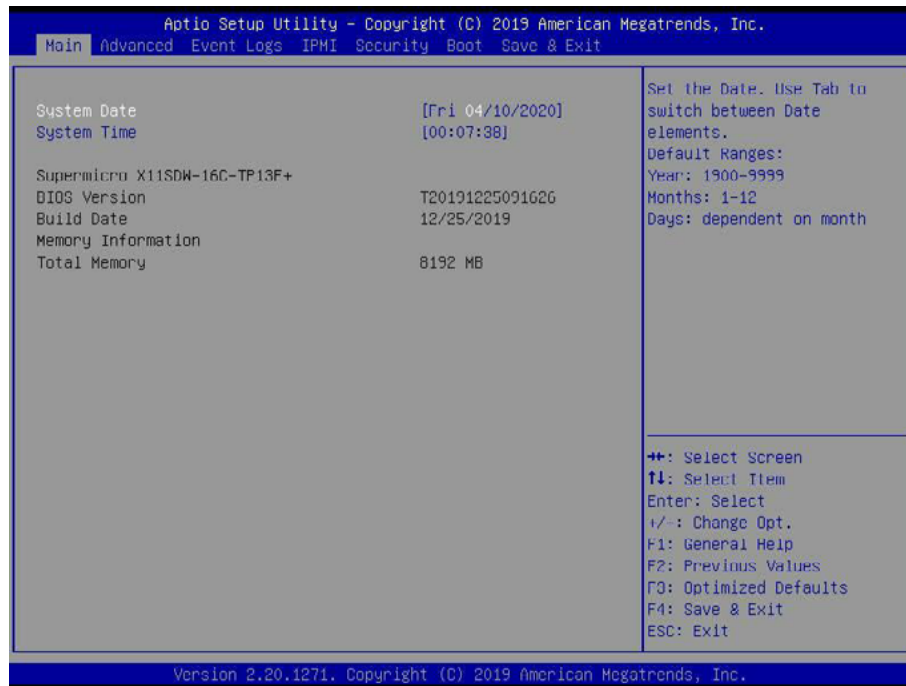

System Date/System Time

Use this option to change the system date and time. Highlight *System Date* or *System Time* using the arrow keys. Enter new values using the keyboard. Press the <Tab> key or the arrow keys to move between fields. The date must be entered in MM/DD/YYYY format. The time is entered in HH:MM:SS format.

Note: The time is in the 24-hour format. For example, 5:30 P.M. appears as 17:30:00. The date's default value is the BIOS build date after RTC reset.

Supermicro X11SDW-16C-TP13F+/X11SDW-14CN-TP13F+

BIOS Version

This feature displays the version of the BIOS ROM used in the system.

Build Date

This feature displays the date when the version of the BIOS ROM used in the system was built.

Memory Information

Total Memory

This feature displays the total size of memory available in the system.

6.3 Advanced

Use this menu to configure advanced settings.

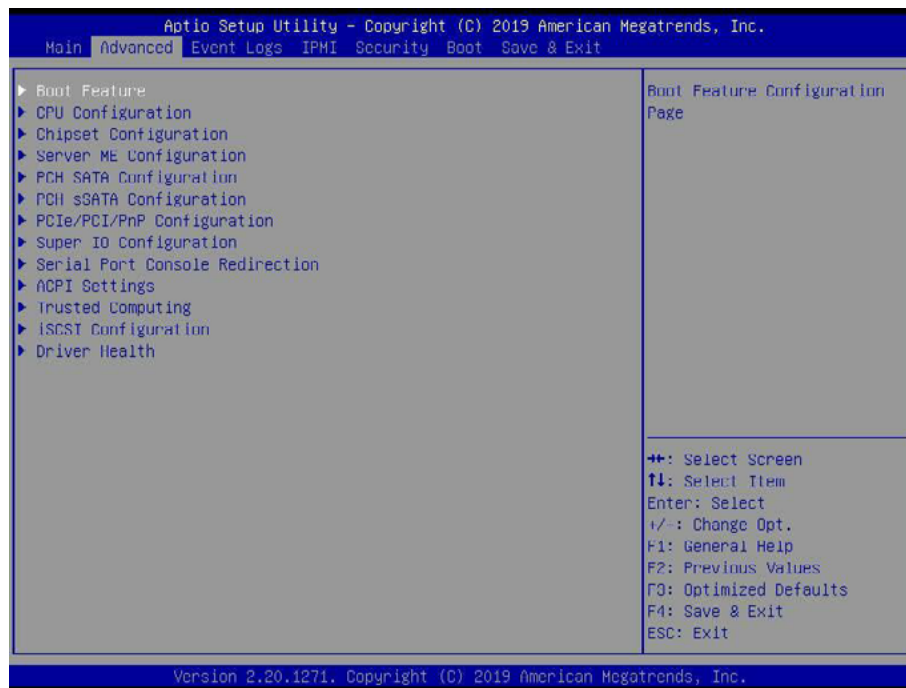

Warning: Take caution when changing the Advanced settings. An incorrect value, a very high DRAM frequency or an incorrect BIOS timing setting may cause the system to malfunction. When this occurs, restore to default manufacturer settings.

► Boot Feature

Quiet Boot

Use this feature to select the screen display between POST messages or the OEM logo at boot up. Select Disabled to display the POST messages. Select Enabled to display the OEM logo instead of the normal POST messages. The options are Disabled and **Enabled**.

Option ROM Messages

Use this feature to set the display mode for the Option ROM. The options are **Force BIOS** and Keep Current.

Bootup NumLock State

Use this feature to set the Power-on state for the Numlock key. The options are Off and **On**.

Wait For "F1" If Error

This feature forces the system to wait until the F1 key is pressed if an error occurs. The options are Disabled and **Enabled**.

INT19 Trap Response

Interrupt 19 is the software interrupt that handles the boot disk function. When this feature is set to Immediate, the ROM BIOS of the host adaptors will "capture" Interrupt 19 at boot up immediately and allow the drives that are attached to these host adaptors to function as bootable disks. If this feature is set to Postponed, the ROM BIOS of the host adaptors will not capture Interrupt 19 immediately and allow the drives attached to these adaptors to function as bootable devices at boot up. The options are **Immediate** and Postponed.

Re-try Boot

If this feature is enabled, the BIOS will automatically reboot the system from a specified boot device after its initial boot failure. The options are **Disabled** and EFI Boot.

Port 61h bit-4 Emulation

Select Enabled to enable the emulation of Port 61h bit-4 toggling in SMM (System Management Mode). The options are **Disabled** and Enabled.

Power Configuration

Watch Dog Function

If enabled, the Watch Dog timer will allow the system to reboot when it is inactive for more than five minutes. The options are **Disabled** and Enabled.

Power Button Function

This feature controls how the system shuts down when the power button is pressed. Select 4 Seconds Override for the user to power off the system after pressing and holding the power button for four seconds or longer. Select Instant Off to instantly power off the system as soon as the user presses the power button. The options are **Instant Off** and 4 Seconds Override.

Restore on AC Power Loss

Use this feature to set the power state after a power outage. Select Power Off for the system power to remain off after a power loss. Select Power On for the system power to be turned on after a power loss. Select Last State to allow the system to resume its last power state before a power loss. The options are Stay Off, Power On, and **Last State**.

►CPU Configuration

The following CPU information will display:

- Processor BSP Revision
- Processor Socket
- Processor ID
- Processor Frequency

- Processor Max Ratio
- Processor Min Ratio
- Microcode Revision
- L1 Cache RAM
- L2 Cache RAM
- L3 Cache RAM
- Processor 0 Version

Hyper-Threading (ALL)

Select Enabled to support Intel Hyper-threading Technology to enhance CPU performance. The options are Disable and **Enable**.

Cores Enabled

Set a numeric value to enable the number of cores. Refer to Intel's website for more information. Enter **0** to enable all cores.

Execute Disable Bit (Available if supported by the OS & the CPU)

Set to Enable for Execute Disable Bit support, which will allow the processor to designate areas in the system memory where an application code can execute and where it cannot, thus preventing a worm or a virus from flooding illegal codes to overwhelm the processor or damage the system during a virus attack. The options are Disable and **Enable**. Refer to Intel and Microsoft websites for more information.

Intel Virtualization Technology

Use this feature to enable the Vanderpool Technology. This technology allows the system to run several operating systems simultaneously. The options are Disable and **Enable**.

PPIN Control

Select Unlock/Enable to use the Protected Processor Inventory Number (PPIN) in the system. The options are Unlock/Disable and **Unlock/Enable**.

Hardware Prefetcher (Available when supported by the CPU)

If set to Enable, the hardware prefetcher will prefetch streams of data and instructions from the main memory to the L2 cache to improve CPU performance. The options are **Enable** and Disable.

Adjacent Cache Prefetch (Available when supported by the CPU)

The CPU prefetches the cache line for 64 bytes if this feature is set to Disabled. The CPU prefetches both cache lines for 128 bytes as comprised if this feature is set to Enable. The options are **Enable** and Disable.

DCU Streamer Prefetcher (Available when supported by the CPU)

Select Enable to enable the DCU (Data Cache Unit) Streamer Prefetcher which will stream and prefetch data and send it to the Level 1 data cache to improve data processing and system performance. The options are **Enable** and Disable.

DCU IP Prefetcher (Available when supported by the CPU)

Select Enable for DCU (Data Cache Unit) IP Prefetcher support, which will prefetch IP addresses to improve network connectivity and system performance. The options are **Enable** and Disable.

LLC Prefetch

If set to Enable, the hardware prefetcher will prefetch streams of data and instructions from the main memory to the L3 cache to improve CPU performance. The options are **Disable** and Enable.

Extended APIC

Select Enable to activate APIC (Advanced Programmable Interrupt Controller) support. The options are **Disable** and Enable.

AES-NI

Select Enable to use the Intel Advanced Encryption Standard (AES) New Instructions (NI) to ensure data security. The options are Disable and **Enable**.

► Advanced Power Management Configuration

Power Technology

This feature allows you to configure CPU power management settings. The options are Disable, **Energy Efficient**, and Custom.

****If the feature above is set to Custom, the following features will be available for configuration:***

Power Performance Tuning

This feature allows you to set whether the operating system or the BIOS controls the Energy Performance BIAS (EPB). The options are **OS Controls EPB** and BIOS Controls EPB.

**If the feature above is set to BIOS Controls EPB, the following features will be available for configuration:*

ENERGY_PERF_BIAS_CFG Mode

The Energy Performance BIAS (EPB) feature allows you to configure CPU power and performance settings. Select Maximum Performance to set the highest performance. Select Performance to optimize performance over energy efficiency. Select Balanced Performance to prioritize performance optimization while conserving energy. Select Balanced Power to prioritize energy conservation while maintaining good performance. Select Power to optimize energy efficiency over performance. The options are Maximum Performance, Performance, **Balanced Performance**, Balanced Power, and Power.

► CPU P State Control

This feature allows you to configure the following CPU power settings:

Uncore Freq Scaling (UFS)

Use this feature to enable or disable uncore frequency scaling. The options are **Enable** and Disable.

SpeedStep (Pstates)

Intel SpeedStep Technology allows the system to automatically adjust processor voltage and core frequency to reduce power consumption and heat dissipation. The options are Disable and **Enable**. This feature must be set to Enable to be able to configure the next two features.

Config TDP

Use this feature to configure the TDP level. The options are **Nominal**, Level 1, and Level 2.

EIST PSD Function

This feature allows you to choose between Hardware and Software to control the processor's frequency and performance (P-state). In HW_ALL mode, the processor hardware is responsible for coordinating the P-state, and the OS is responsible for keeping the P-state request up to date on all Logical Processors. In SW_ALL mode, the OS Power Manager is responsible for coordinating the P-state, and must initiate the transition on all Logical Processors. In SW_ANY mode, the OS Power Manager is responsible for coordinating the P-state and may initiate the transition on any Logical Processors. The options are **HW_ALL** and SW_ALL.

Energy Efficient Turbo

Use this feature to enable or disable energy efficient turbo. The options are **Enable** and Disable.

Turbo Mode

This feature will enable dynamic control of the processor, allowing it to run above stock frequency. The options are Disable and **Enable**.

► Hardware PM State Control

Hardware P-States

This setting allows you to select between OS and hardware-controlled P-states. Selecting Native Mode allows the OS to choose a P-state. Selecting Out of Band Mode allows the hardware to autonomously choose a P-state without OS guidance. Selecting Native Mode with No Legacy Support functions as Native Mode with no support for older hardware. The options are **Disable**, Native Mode, Out of Band Mode, and Native Mode with No Legacy Support.

► CPU C State Control

Autonomous Core C-State

Enabling this setting allows the hardware to autonomously choose to enter a C-state based on power consumption and clock speed. The options are **Disable** and Enable. This feature must be set to Disable to be able to configure the next two features.

CPU C6 report

Select Enable to allow the BIOS to report the CPU C6 State (ACPI C3) to the operating system. During the CPU C6 State, the power to all cache is turned off. The options are Disable, Enable, and **Auto**.

Enhanced Halt State (C1E)

Select Enable to use Enhanced Halt State technology, which will significantly reduce the CPU's power consumption by reducing its clock cycle and voltage during a Halt state. The options are Disable and **Enable**.

► Package C State Control

Package C State

This feature allows you to set the limit on the C State package register. The options are C0/C1 State, C2 State, C6 (Non Retention) State, C6 (Retention) State, No Limit, and **Auto**.

▶ CPU T State Control

Software Controlled T-States

Use this feature to enable Software Controlled T-States. The options are Disable and Enable.

▶ Chipset Configuration

Warning: Setting the wrong values in the sections below may cause the system to malfunction.

▶ North Bridge Configuration

▶ Memory Configuration

Enforce POR

Select POR (Plan of Record) to enforce POR restrictions on DDR4 frequency and voltage programming. The options are **POR** and Disable.

Memory Frequency

Use this feature to set the maximum memory frequency for onboard memory modules. The options are **Auto**, 2133, 2400, and 2666.

Data Scrambling for DDR4

Use this feature to enable or disable data scrambling for DDR4 memory. The options are **Auto**, Disable, and Enable.

tCCD_L Relaxation

Select Auto to get TCDD settings from SPD (Serial Presence Detect) into memory RC code to improve system reliability. Select Disable for TCCD to follow Intel POR. The options are Disable and **Auto**.

2X REFRESH

Use this feature to select the memory controller refresh rate to 2x refresh mode. The options are **Auto** and Enable.

▶ Memory Topology

This feature displays the information of onboard memory modules detected by the BIOS.

► Memory RAS Configuration

Static Virtual Lockstep Mode

Select Enable to run the system's memory channels in lockstep mode to minimize memory access latency. The options are **Disable** and Enable.

Mirror Mode

This feature allows memory to be mirrored between two channels, providing 100% redundancy. The options are **Disable** and Enable Mirror Mode (1LM).

Memory Rank Sparing

Select Enable to enable memory-sparing support for memory ranks to improve memory performance. The options are **Disable** and Enable.

****If the feature above is set to Enable, Multi Rank Sparing will be available for configuration:***

Multi Rank Sparing

Use this feature to indicate how many memory ranks to reserve in case of memory failure. The options are One Rank and **Two Rank**.

Correctable Error Threshold

Use this feature to specify the threshold value for correctable memory error logging, which sets a limit on the maximum number of events that can be logged in the memory error log at a given time. The default setting is **100**.

SDDC

Single device data correction +1 (SDDC Plus One) organizes data in a single bundle (x4/x8 DRAM). If any or all of the bits become corrupted, corrections occur. The x4 condition is corrected on all cases. The x8 condition is corrected only if the system is in Lockstep Mode. The options are **Disable** and Enable.

ADDDC Sparing

Adaptive Double Device Data Correction (ADDDC) Sparing detects when the predetermined threshold for correctable errors is reached, copying the contents of the failing DIMM to spare memory. The failing DIMM or memory rank will then be disabled. The options are **Disable** and Enable.

Patrol Scrub

Patrol Scrub is a process that allows the CPU to correct correctable memory errors detected on a memory module and send the correction to the requestor (the original source). When this feature is set to Enable, the IO hub will read and write back one cache line every 16K cycles if there is no delay caused by internal processing. By using this method, roughly 64 GB of memory behind the IO hub will be scrubbed every day. The options are Disable and **Enable**.

****If the feature above is set to Enable, Patrol Scrub Interval will be available for configuration:***

Patrol Scrub Interval

This feature allows you to decide how many hours the system should wait before the next complete patrol scrub is performed. Use the keyboard to enter a value from 0-24. The default setting is **24**.

► IIO Configuration

EV DFX Features

When this feature is set to Enable, the EV_DFX Lock Bits that are located on a processor will always remain clear during electric tuning. The options are **Disable** and Enable.

► CPU Configuration

IOU0 (IIO PCIe Br1)

Use this feature to configure the PCI-E port Bifurcation setting for a PCI-E port specified by the user. The options are x4x4x4x4, x4x4x8, x8x4x4, x8x8, x16, and **Auto**.

IOU1 (IIO PCIe Br2)

Use this feature to configure the PCI-E port Bifurcation setting for a PCI-E port specified by the user. The options are x4x4x4x4, x4x4x8, x8x4x4, x8x8, x16, and **Auto**.

IOU2 (IIO PCIe Br3)

Use this feature to configure the PCI-E port Bifurcation setting for a PCI-E port specified by the user. The options are x4x4x4x4, x4x4x8, x8x4x4, x8x8, x16, and **Auto**.

► RSU-R1UW-2E16 SLOT1 / RSU-R1UW-2E16 SLOT2 (Option Riser Card)

Link Speed

Use this feature to select the link speed for this port. The options are **Auto**, Gen 1 (2.5 GT/s), Gen 2 (5GT/s), and Gen 3 (GT/s).

PCI-E Port Link Status

This feature shows the status of the device plugged into this slot.

PCI-E Port Link Max

This feature shows the status of the device plugged into this slot.

PCI-E Port Link Speed

This feature shows the status of the device plugged into this slot.

PCI-E Port Max Payload Size

Use this feature to select the maximum payload size for this port. The options are 128B, 256B, and **Auto**.

► IOAT Configuration

Disable TPH

Transparent Huge Pages (TPH) is a Linux memory management system that enables communication in larger blocks (pages). Enabling this feature will increase performance. The options are **No** and Yes.

****If the feature above is set to No, Relax Ordering will be available for configuration:***

Prioritize TPH

Select Yes to prioritize TPL requests that will allow the hints to be sent to help facilitate and optimize the processing of certain transactions in the system memory. The options are Enable and **Disable**.

Relaxed Ordering

Select Enable to enable Relaxed Ordering support, which will allow certain transactions to violate the strict-ordering rules of PCI bus for a transaction to be completed prior to other transactions that have already been enqueued. The options are **Disable** and Enable.

► Intel® VT for Directed I/O (VT-d)

Intel® VT for Directed I/O (VT-d)

Select Enable to use Intel Virtualization Technology for Direct I/O VT-d support by reporting the I/O device assignments to the VMM (Virtual Machine Monitor) through the DMAR ACPI tables. This feature offers fully-protected I/O resource sharing across Intel platforms, providing greater reliability, security, and availability in networking and data-sharing. The options are **Enable** and Disable.

****If the feature above is set to Enable, the five features below will be available for configuration:***

Interrupt Remapping

Use this feature to enable Interrupt Remapping support, which detects and controls external interrupt requests. The options are **Enable** and Disable.

PassThrough DMA

Use this feature to allow devices such as network cards to access the system memory without using a processor. Select Enable to use the Non-Isoch VT-d Engine Pass Through Direct Memory Access (DMA) support. The options are **Enable** and Disable.

ATS

Use this feature to enable Non-Isoch VT-d Engine Address Translation Services (ATS) support. ATS translates virtual addresses to physical addresses. The options are **Enable** and Disable.

Posted Interrupt

Use this feature to enable VT-d Posted Interrupt. The options are **Enable** and Disable.

Coherency Support (Non-Isoch)

Use this feature to maintain setting coherency between processors or other devices. Select Enable for the Non-Isoch VT-d engine to pass through DMA to enhance system performance. The options are **Enable** and Disable.

► Intel® VMD Technology

Note: After you've enabled VMD on a PCI-E slot of your choice, this PCI-E slot will be dedicated for NVMe storage devices use only, and it will no longer support PCI-E devices of other functionalities. To re-activate this slot for PCI-E use, please disable VMD.

► Intel® VMD for Volume Management Device on CPU

VMD Config for PStack0

Intel® VMD for Volume Management Device

Select Enable to use the Intel Volume Management Device Technology for this stack. The options are **Disable** and Enable.

****If the feature Intel VMD for Volume Management Device above is set to Enable, the following features are available for configuration:***

RSC-R1UW-2E16 SLOT1 VMD (Available when detected by the system)

Select Enable to use the Intel Volume Management Device Technology for this specific root port. The options are **Disable** and Enable.

Hot Plug Capable (Available when the device is detected by the system)

Use this feature to enable hot plug support for PCIe root ports 1A~1D. The options are **Disable** and Enable.

VMD Config for PStack1

Intel® VMD for Volume Management Device

Select Enable to use the Intel Volume Management Device Technology for this stack. The options are **Disable** and Enable.

****If the feature "Intel VMD for Volume Management Device" above is set to Enable, the following features are available for configuration:***

RSC-R1UW-2E16 SLOT2 VMD (Available when detected by the system)

Select Enable to use the Intel Volume Management Device Technology for this specific root port. The options are **Disable** and Enable.

Hot Plug Capable (Available when the device is detected by the system)

Use this feature to enable hot plug support for PCIe root ports 2A~2D. The options are **Disable** and Enable.

VMD Config for PStack1

Intel® VMD for Volume Management Device

Select Enable to use the Intel Volume Management Device Technology for this stack. The options are **Disable** and Enable.

****If the feature Intel VMD for Volume Management Device above is set to Enable, the following features are available for configuration:***

RSC-R1UW-2E16 SLOT2 VMD (Available when detected by the system)

Select Enable to use the Intel Volume Management Device Technology for this specific root port. The options are **Disable** and Enable.

Hot Plug Capable (Available when the device is detected by the system)

Use this feature to enable hot plug support for PCIe root ports 2A~2D. The options are **Disable** and Enable.

PCI-E Completion Timeout Disable

Use this feature to enable PCI-E Completion Timeout support for electric tuning. The options are Yes, **No**, and Per-Port.

►South Bridge Configuration

The following South Bridge information will display:

- USB Module Version
- USB Devices

Legacy USB Support

Select Enabled to support onboard legacy USB devices. Select Auto to disable legacy support if there are no legacy USB devices present. Select Disable to have all USB devices available for EFI applications only. The options are **Enabled**, Disabled, and Auto.

XHCI Hand-off

This is a workaround solution for operating systems that do not support XHCI (Extensible Host Controller Interface) hand-off. The XHCI ownership change should be claimed by the XHCI driver. The settings are Enabled and **Disabled**.

Port 60/64 Emulation

Select Enabled for I/O port 60h/64h emulation support, which in turn will provide complete legacy USB keyboard support for the operating systems that do not support legacy USB devices. The options are Disabled and **Enabled**.

►Server ME Configuration

- General ME Configuration
- Oper. Firmware Version
- Backup Firmware Version
- Recovery Firmware Version
- ME Firmware Status #1
- ME Firmware Status #2
- Current State
- Error Code

► PCH SATA Configuration

When this submenu is selected, the AMI BIOS automatically detects the presence of the SATA devices that are supported by the Intel PCH chip and displays the following features:

SATA Controller

Use this feature to enable or disable the onboard SATA controller supported by the Intel PCH chip. The options are Disable and **Enable**.

**If the feature above is set to enabled, SATA HDD Unlock is available for configuration:*

SATA HDD Unlock

This feature allows you to remove any password-protected SATA disk drives. The options are **Enable** and Disable.

Aggressive Link Power Management

When this feature is set to Enable, the SATA AHCI controller manages the power usage of the SATA link. The controller will put the link in a low power mode during extended periods of I/O inactivity, and will return the link to an active state when I/O activity resumes. The options are **Disable** and Enable.

SATA Port 4

This feature displays the information detected on the installed SATA drive on the particular SATA port.

- Model number of drive and capacity
- Software Preserve Support

SATA Port 4 Hot Plug

Set this feature to Enable for hot plug support, which will allow the user to replace a SATA drive without shutting down the system. The options are Disable and **Enable**.

SATA Port 4 Spin Up Device

Set this feature to enable or disable the PCH to initialize the device. The options are **Disable** and Enable.

SATA Port 4 SATA Device Type

Use this feature to specify if the SATA port specified by the user should be connected to a Solid State Drive or a Hard Disk Drive. The options are **Hard Disk Drive** and Solid State Drive.

► PCH sSATA Configuration

When this submenu is selected, the AMI BIOS automatically detects the presence of the SATA devices that are supported by the Intel PCH chip and displays the following features:

sSATA Controller

This feature enables or disables the onboard sSATA controller supported by the Intel PCH chip. The options are **Enable** and Disable.

Configure sSATA as

Select AHCI to configure an sSATA drive specified by the user as an AHCI drive. Select RAID to configure an sSATA drive specified by the user as a RAID drive. The options are **AHCI** and RAID.

SATA HDD Unlock

This feature allows you to remove any password-protected SATA disk drives. The options are Disable and **Enable**.

****If the feature Configure sSATA as above is set to RAID, sSATA RSTe Boot Info and sSATA RAID Option ROM/UEFI Driver will be available for configuration:***

sSATA RSTe Boot Info

Select Enable to provide full int13h support for the devices attached to sSATA controller. The options are Disable and **Enable**.

Aggressive Link Power Management

When this feature is set to Enable, the SATA AHCI controller manages the power usage of the SATA link. The controller will put the link in a low power mode during extended periods of I/O inactivity and will return the link to an active state when I/O activity resumes. The options are **Disable** and Enable.

sSATA RAID Option ROM/UEFI Driver

Select UEFI to load the EFI driver for system boot. Select Legacy to load a legacy driver for system boot. The options are Disable, EFI, and **Legacy**.

sSATA Port 0 ~ Port 4

This feature displays the information detected on the installed sSATA drive on the particular sSATA port.

- Model number of drive and capacity
- Software Preserve Support

Port 0 ~ Port 4 Hot Plug

Set this feature to Enable for hot plug support, which will allow the user to replace a SATA drive without shutting down the system. The options are Disable and **Enable**.

Port 0 ~ Port 4 Spin Up Device

Set this feature to enable or disable the PCH to initialize the device. The options are **Disable** and Enable.

Port 0 ~ Port 4 sSATA Device Type

Use this feature to specify if the SATA port specified by the user should be connected to a Solid State Drive or a Hard Disk Drive. The options are **Hard Disk Drive** and Solid State Drive.

► PCIe/PCI/PnP Configuration

The following information will display:

- PCI Bus Driver Version
- PCI Devices Common Settings:

Above 4G Decoding (Available if the system supports 64-bit PCI decoding)

Select Enabled to decode a PCI device that supports 64-bit in the space above 4G Address. The options are Disabled and **Enabled**.

SR-IOV Support

Use this feature to enable or disable Single Root IO Virtualization Support. The options are **Disabled** and Enabled.

BME DMA Mitigation

Enable this feature to help block DMA attacks. The options are Enabled and **Disabled**.

MMIO High Base

Use this feature to select the base memory size according to memory-address mapping for the IO hub. The options are **56T**, 40T, 24T, 16T, 4T, and 1T.

MMIO High Granularity Size

Use this feature to select the high memory size according to memory-address mapping for the IO hub. The options are 1G, 4G, 16G, 64G, **256G**, and 1024G.

Maximum Read Request

Use this feature to select the Maximum Read Request size of the PCI-Express device, or select Auto to allow the System BIOS to determine the value. The options are **Auto**, 128 Bytes, 256 Bytes, 512 Bytes, 1024 Bytes, 2048 Bytes, and 4096 Bytes.

MMCFG Base

Use this feature to select the low base address for PCI-E adapters to increase base memory. The options are 1G, 1.5G, 1.75G, **2G**, 2.25G, and 3G.

NVMe Firmware Source

Use this feature to select the NVMe firmware to support booting. The default option, Vendor Defined Firmware, is pre-installed on the drive and may resolve errata or enable innovative functions for the drive. The other option, AMI Native Support, is offered by the BIOS with a generic method. The options are **Vendor Defined Firmware** and AMI Native Support.

VGA Priority

Use this feature to select VGA priority when multiple VGA devices are detected. Select Onboard to give priority to your onboard video device. Select Offboard to give priority to your graphics card. The options are **Onboard** and Offboard.

Consistent Device Name Support

Select enabled for the BIOS to consistently name network devices. The options are Disabled and **Enabled**.

JMD2: M.2-H PCI-E 3.0 X2 lane 1 Type

Use this feature to select the I/O type for this slot. The options are **PCIE** and USB 3.0.

JMD1: M.2-H PCI-E 3.0 X4 OPROM

Use this feature to select which firmware type to be loaded for the add-on card in this slot. The options are Disabled, **Legacy**, and EFI.

JMD2: M.2-H PCI-E 3.0 X2 OPROM

Use this feature to select which firmware type to be loaded for the add-on card in this slot. The options are Disabled, **Legacy**, and EFI.

JMD3: M.2-P PCI-E 3.0 X1 OPROM

Use this feature to select which firmware type to be loaded for the add-on card in this slot. The options are Disabled, **Legacy**, and EFI.

RSC-R1UW-2E16 SLOT1 PCI-E 3.0 X16 OPROM (Option RISER Card)

Use this feature to select which firmware type to be loaded for the add-on card in this slot. The options are Disabled, **Legacy**, and EFI.

RSC-R1UW-2E16 SLOT2 PCI-E 3.0 X16 OPROM (Option RISER Card)

Use this feature to select which firmware type to be loaded for the add-on card in this slot. The options are Disabled, **Legacy**, and EFI.

Onboard LAN Option ROM Type

Use this feature to select which firmware type to be loaded for onboard LAN devices. The options **Legacy** and EFI. Select Legacy to display and configure the Onboard LAN1 - LAN13 Option ROM features.

Onboard LAN1 - LAN13 Option ROM

Use this feature to select which firmware function to be loaded for the specified LAN port used for system boot. The options for LAN1 Disabled, **PXE**, and iSCSI. The options are LAN2 - LAN13 are **Disabled** and PXE.

Onboard Video Option ROM

Use this feature to select the Onboard Video Option ROM type. The options are Disabled, **Legacy**, and EFI.

► Network Stack Configuration

Network Stack

Select Enabled to enable PXE (Preboot Execution Environment) or UEFI (Unified Extensible Firmware Interface) for network stack support. The options are **Enabled** and Disabled.

****If the feature above is set to Enabled, the next six features will be available for configuration:***

Ipv4 PXE Support

Select Enabled to enable IPv4 PXE boot support. The options are Disabled and **Enabled**.

Ipv4 HTTP Support

Select Enabled to enable IPv4 HTTP boot support. The options are **Disabled** and Enabled.

Ipv6 PXE Support

Select Enabled to enable IPv6 PXE boot support. The options are **Disabled** and Enabled.

Ipv6 HTTP Support

Select Enabled to enable IPv6 HTTP boot support. The options are **Disabled** and Enabled.

PXE boot wait time

Use this option to specify the wait time to press the ESC key to abort the PXE boot. Press "+" or "-" on your keyboard to change the value. The default setting is **0**.

Media detect count

Use this option to specify the number of times media will be checked. Press "+" or "-" on your keyboard to change the value. The default setting is **1**.

► Super IO Configuration

Super IO Chip AST2500

► Serial Port 1 Configuration

Serial Port 1

Select Enabled to enable the onboard serial port specified by the user. The options are **Enabled** and Disabled. Enable this feature for the next two features to display and only the Change Settings feature is available for configuration.

Device Settings

This feature displays the base I/O port address and the Interrupt Request address of a serial port specified by the user.

Change Settings

This feature specifies the base I/O port address and the Interrupt Request address of Serial Port 1. Select **Auto** for the BIOS to automatically assign the base I/O and IRQ address to a serial port specified. The options are **Auto**, (IO=3F8h; IRQ=4), (IO=2F8h; IRQ=4), (IO=3E8h; IRQ=4), and (IO=2E8h; IRQ=4).

► Serial Port 2 Configuration

Serial Port 2

Select Enabled to enable the onboard serial port specified by the user. The options are **Enabled** and Disabled. Enable this feature for the next two features to display and only the Change Settings feature is available for configuration.

Device Settings

This feature displays the base I/O port address and the Interrupt Request address of a serial port specified by the user.

Change Settings

This feature specifies the base I/O port address and the Interrupt Request address of Serial Port 1. Select **Auto** for the BIOS to automatically assign the base I/O and IRQ address to a serial port specified. The options are **Auto**, (IO=2F8h; IRQ=3), (IO=3F8h; IRQ=3), (IO=3E8h; IRQ=3), and (IO=2E8h; IRQ=3).

Serial Port 2 Attribute

Select SOL to use COM Port 2 as a Serial Over LAN (SOL) port for console redirection. The options are **SOL** and **COM**.

►Serial Port Console Redirection

COM1

Console Redirection

Select Enabled to enable COM Port 1 for Console Redirection, which will allow a client machine to be connected to a host machine at a remote site for networking. The options are **Disabled** and **Enabled**.

****If the feature above is set to Enabled, the following features will become available for configuration:***

►Console Redirection Settings

Terminal Type

This feature allows you to select the target terminal emulation type for Console Redirection. Select VT100 to use the ASCII Character set. Select VT100+ to add color and function key support. Select ANSI to use the Extended ASCII Character Set. Select VT-UTF8 to use UTF8 encoding to map Unicode characters into one or more bytes. The options are VT100, **VT100+**, VT-UTF8, and ANSI.

Bits per second

Use this feature to set the transmission speed for a serial port used in Console Redirection. Make sure that the same speed is used in the host computer and the client computer. A lower transmission speed may be required for long and busy lines. The options are 9600, 19200, 38400, 57600, and **115200** (bits per second).

Data Bits

Use this feature to set the data transmission size for Console Redirection. The options are 7 and **8**.

Parity

A parity bit can be sent along with regular data bits to detect data transmission errors. Select Even if the parity bit is set to 0, and the number of 1's in data bits is even. Select Odd if the parity bit is set to 0, and the number of 1's in data bits is odd. Select None if you do not want to send a parity bit with your data bits in transmission. Select Mark to add a mark as a parity bit to be sent along with the data bits. Select Space to add a Space as a parity bit to be sent with your data bits. The options are **None**, Even, Odd, Mark, and Space.

Stop Bits

A stop bit indicates the end of a serial data packet. Select 1 Stop Bit for standard serial data communication. Select 2 Stop Bits if slower devices are used. The options are **1** and **2**.

Flow Control

Use this feature to set the flow control for Console Redirection to prevent data loss caused by buffer overflow. Send a "Stop" signal to stop sending data when the receiving buffer is full. Send a "Start" signal to start sending data when the receiving buffer is empty. The options are **None** and Hardware RTS/CTS.

VT-UTF8 Combo Key Support

Select Enabled to enable VT-UTF8 Combination Key support for ANSI/VT100 terminals. The options are Disabled and **Enabled**.

Recorder Mode

Select Enabled to capture the data displayed on a terminal and send it as text messages to a remote server. The options are **Disabled** and Enabled.

Resolution 100x31

Select Enabled for extended-terminal resolution support. The options are Disabled and **Enabled**.

Legacy OS Redirection Resolution

Use this feature to select the number of rows and columns used in Console Redirection for legacy OS support. The options are **80x24** and 80x25.

Putty KeyPad

This feature selects Function Keys and KeyPad settings for Putty, which is a terminal emulator designed for the Windows OS. The options are **VT100**, LINUX, XTERMR6, SCO, ESCN, and VT400.

Redirection After BIOS POST

Use this feature to enable or disable legacy console redirection after BIOS POST. When set to BootLoader, legacy console redirection is disabled before booting the OS. When set to Always Enable, legacy console redirection remains enabled when booting the OS. The options are **Always Enable** and BootLoader.

SOL/COM2**Console Redirection**

Select Enabled to use the SOL port for Console Redirection. The options are Disabled and **Enabled**.

****If the feature above is set to Enabled, the following features are available for configuration:***

► Console Redirection Settings

Use this feature to specify how the host computer will exchange data with the client computer, which is the remote computer used by the user.

SOL/COM2

Terminal Type

Use this feature to select the target terminal emulation type for Console Redirection. Select VT100 to use the ASCII Character set. Select VT100+ to add color and function key support. Select ANSI to use the Extended ASCII Character Set. Select VT-UTF8 to use UTF8 encoding to map Unicode characters into one or more bytes. The options are VT100, **VT100+**, VT-UTF8, and ANSI.

Bits per second

Use this feature to set the transmission speed for a serial port used in Console Redirection. Make sure that the same speed is used in the host computer and the client computer. A lower transmission speed may be required for long and busy lines. The options are 9600, 19200, 38400, 57600, and **115200** (bits per second).

Data Bits

Use this feature to set the data transmission size for Console Redirection. The options are 7 and 8.

Parity

A parity bit can be sent along with regular data bits to detect data transmission errors. Select Even if the parity bit is set to 0, and the number of 1's in data bits is even. Select Odd if the parity bit is set to 0, and the number of 1's in data bits is odd. Select None if you do not want to send a parity bit with your data bits in transmission. Select Mark to add a mark as a parity bit to be sent along with the data bits. Select Space to add a Space as a parity bit to be sent with your data bits. The options are **None**, Even, Odd, Mark and Space.

Stop Bits

A stop bit indicates the end of a serial data packet. Select 1 Stop Bit for standard serial data communication. Select 2 Stop Bits if slower devices are used. The options are **1** and 2.

Flow Control

Use this feature to set the flow control for Console Redirection to prevent data loss caused by buffer overflow. Send a "Stop" signal to stop sending data when the receiving buffer is full. Send a "Start" signal to start sending data when the receiving buffer is empty. The options are **None** and Hardware RTS/CTS.

VT-UTF8 Combo Key Support

Select Enabled to enable VT-UTF8 Combination Key support for ANSI/VT100 terminals. The options are Disabled and **Enabled**.

Recorder Mode

Select Enabled to capture the data displayed on a terminal and send it as text messages to a remote server. The options are **Disabled** and Enabled.

Resolution 100x31

Select Enabled for extended-terminal resolution support. The options are Disabled and **Enabled**.

Legacy OS Redirection Resolution

Use this feature to select the number of rows and columns used in Console Redirection for legacy OS support. The options are **80x24** and 80x25.

Putty KeyPad

This feature selects Function Keys and KeyPad settings for Putty, which is a terminal emulator designed for the Windows OS. The options are **VT100**, LINUX, XTERMR6, SCO, ESCN, and VT400.

Redirection After BIOS POST

Use this feature to enable or disable legacy console redirection after BIOS POST. When set to BootLoader, legacy console redirection is disabled before booting the OS. When set to Always Enable, legacy console redirection remains enabled when booting the OS. The options are **Always Enable** and BootLoader.

Legacy Console Redirection**Redirection COM Port**

Use this feature to select a COM port to display redirection of Legacy OS and Legacy OPROM messages. The options are **COM1** and SOL/COM2.

Serial Port for Out-of-Band Management/Windows Emergency Management Services (EMS)

This submenu allows you to configure Console Redirection settings to support Out-of-Band Serial Port management.

Console Redirection

Select Enabled to use a COM port selected by the user for EMS Console Redirection. The options are **Disabled** and Enabled.

****If the feature above is set to Enabled, the following features are available for configuration:***

► Console Redirection Settings

This feature allows you to specify how the host computer will exchange data with the client computer, which is the remote computer used by the user.

Out-of-Band Mgmt Port

The feature selects a serial port in a client server to be used by the Microsoft Windows Emergency Management Services (EMS) to communicate with a remote host server. The options are **COM1** and SOL/COM2.

Terminal Type

Use this feature to select the target terminal emulation type for Console Redirection. Select VT100 to use the ASCII character set. Select VT100+ to add color and function key support. Select ANSI to use the extended ASCII character set. Select VT-UTF8 to use UTF8 encoding to map Unicode characters into one or more bytes. The options are VT100, VT100+, **VT-UTF8**, and ANSI.

Bits per second

This feature sets the transmission speed for a serial port used in Console Redirection. Make sure that the same speed is used in the host computer and the client computer. A lower transmission speed may be required for long and busy lines. The options are 9600, 19200, 57600, and **115200** (bits per second).

Flow Control

Use this feature to set the flow control for Console Redirection to prevent data loss caused by buffer overflow. Send a "Stop" signal to stop sending data when the receiving buffer is full. Send a "Start" signal to start sending data when the receiving buffer is empty. The options are **None**, Hardware RTS/CTS, and Software Xon/Xoff.

Data Bits

Parity

Stop Bits

► ACPI Settings

Use this feature to configure Advanced Configuration and Power Interface (ACPI) power management settings for your system.

Headless Support

Enable this feature for the system to function without a keyboard, monitor, or mouse attached. The options are **Disabled** and Enabled.

WHEA Support

Select Enabled to support the Windows Hardware Error Architecture (WHEA) platform and provide a common infrastructure for the system to handle hardware errors within the Windows OS environment in order to reduce system crashes and enhance system recovery and health monitoring. The options are Disabled and **Enabled**.

High Precision Event Timer

Select Enabled to activate the High Precision Event Timer (HPET) that produces periodic interrupts at a much higher frequency than a Real-time Clock (RTC) does in synchronizing multimedia streams, providing smooth playback and reducing the dependency on other timestamp calculation devices, such as an x86 RDTSC Instruction embedded in the CPU. The High Performance Event Timer is used to replace the 8254 Programmable Interval Timer. The options are Disabled and **Enabled**.

► Trusted Computing

This motherboard supports TPM 1.2 and 2.0. The following Trusted Platform Module (TPM) information will display if a TPM 2.0 module is detected:

TPM20 Device Found

Vendor:

Firmware Version:

Security Device Support

If this feature and the TPM jumper on the motherboard are both set to Enabled, onboard security devices will be enabled for TPM support to enhance data integrity and network security. Reboot the system for a change on this setting to take effect. The options are Disable and **Enable**.

The following TPM information will be displayed:

- Active PCR banks
- Available PCR banks

****If the feature "Security Device Support" is enabled, the following features are available for configuration:***

SHA256 PCR Bank

Use this item to disable or enable the SHA256 Platform Configuration Register (PCR) bank for the installed TPM device. The options are Disabled and **Enabled**.

Pending Operation

Use this feature to schedule a TPM-related operation to be performed by a security device for system data integrity. Your system will reboot to carry out a pending TPM operation. The options are **None** and TPM Clear.

Platform Hierarchy

Use this feature to disable or enable platform hierarchy for platform protection. The options are Disabled and **Enabled**.

Storage Hierarchy

Use this feature to disable or enable storage hierarchy for cryptographic protection. The options are Disabled and **Enabled**.

Endorsement Hierarchy

Use this feature to disable or enable endorsement hierarchy for privacy control. The options are Disabled and **Enabled**.

SMCI BIOS-Based TPM Provision Support

Use feature to enable the Supermicro TPM Provision support. The options are **Disabled** and Enabled.

TXT Support

Intel TXT (Trusted Execution Technology) helps protect against software-based attacks and ensures protection, confidentiality and integrity of data stored or created on the system. Use this feature to enable or disable TXT Support. The options are **Disabled** and Enabled.

► iSCSI Configuration

iSCSI Initiator Name

This feature allows you to enter the unique name of the iSCSI Initiator in IQN format. Once the name of the iSCSI Initiator is entered into the system, configure the proper settings for the following features.

► **Add an Attempt**

► **Delete Attempts**

► **Change Attempt Order**

► Driver Health

This submenu displays the health status of the drivers and controllers below.

► **Apache Pass 1.0.0.1970 Driver**

6.4 Event Logs

Use this menu to configure event log settings.

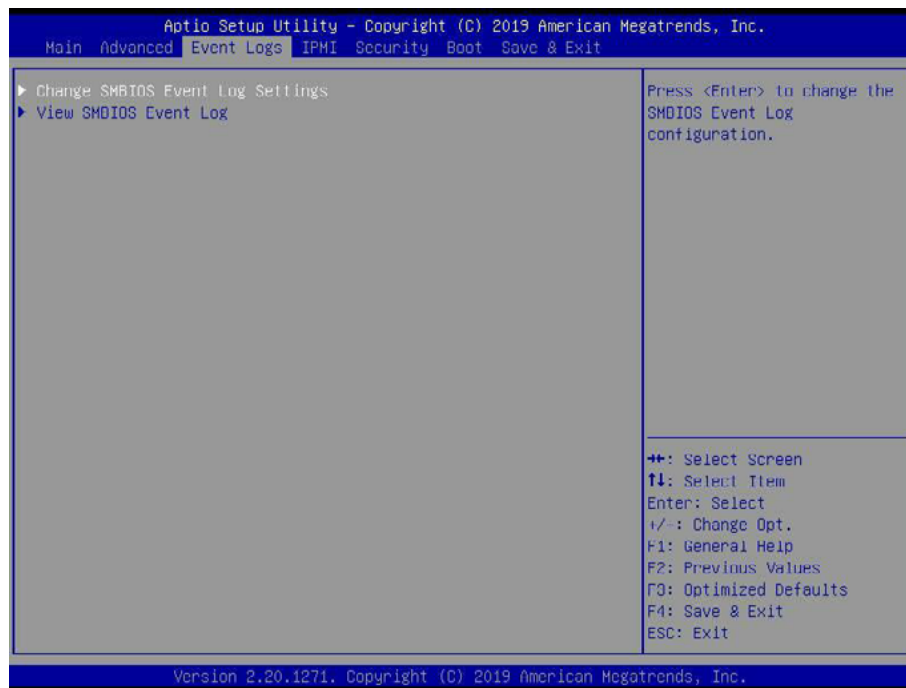

► Change SMBIOS Event Log Settings

Enabling/Disabling Options

SMBIOS Event Log

Change this feature to enable or disable all features of the SMBIOS Event Logging during system boot. The options are Disabled and **Enabled**.

Erasing Settings

Erase Event Log

Select Enabled to erase all error events in the SMBIOS (System Management BIOS) log before an event logging is initialized at boot up. The options are **No**, "Yes, Next reset," and "Yes, Every reset."

When Log is Full

Select Erase Immediately to immediately erase all errors in the SMBIOS event log when the event log is full. Select Do Nothing for the system to do nothing when the SMBIOS event log is full. The options are **Do Nothing** and Erase Immediately.

SMBIOS Event Log Standard Settings

Log System Boot Event

Select Enabled to log system boot events. The options are Enabled and **Disabled**.

MECI (Multiple Event Count Increment)

Enter the increment value for the multiple event counter. Enter a number between 1 to 255. The default setting is **1**.

METW (Multiple Event Count Time Window)

This feature is used to determine how long (in minutes) the multiple event counter should wait before generating a new event log. Enter a number between 0 to 99. The default setting is **60**.

Note: Reboot the system for the changes to take effect.

►View SMBIOS Event Log

This feature allows you to view the event in the SMBIOS event log. The following categories are displayed:

DATE/TIME/ERROR CODE/SEVERITY

6.5 IPMI

Use this menu to configure Intelligent Platform Management Interface (IPMI) settings.

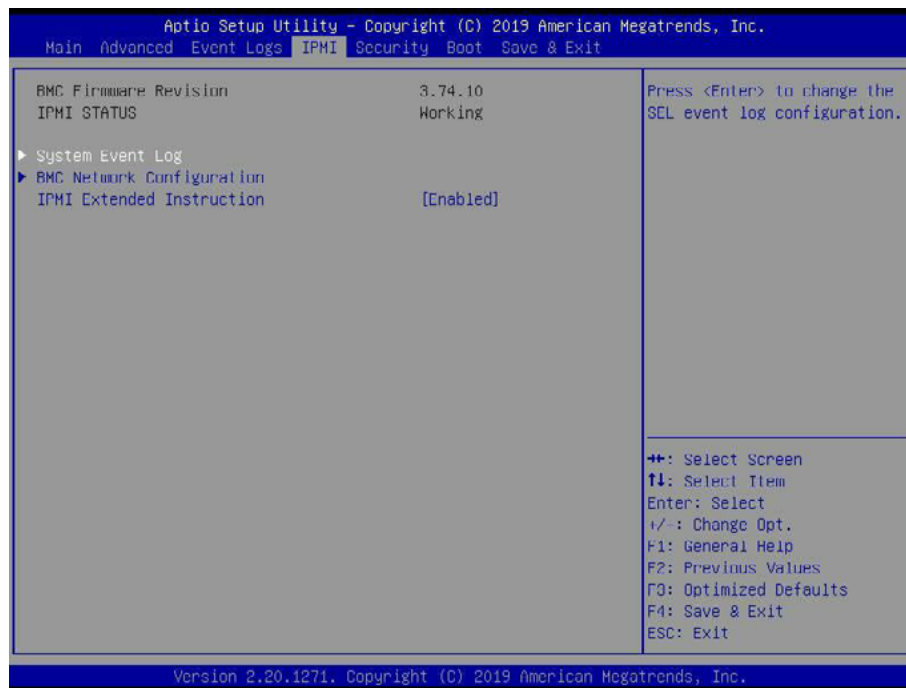

BMC Firmware Revision

This feature displays the IPMI firmware revision used in your system.

IPMI STATUS

This feature displays the status of the IPMI firmware installed in your system.

► System Event Log

Enabling/Disabling Options

SEL Components

Select Enabled for all system event logging at boot up. The options are Disabled and Enabled.

Erasing Settings

Erase SEL

Select Yes, On next reset to erase all system event logs upon next system reboot. Select Yes, On every reset to erase all system event logs upon each system reboot. Select No to keep all system event logs after each system reboot. The options are **No**, "Yes, On next reset," and "Yes, On every reset."

When SEL is Full

This feature allows you to determine what the BIOS should do when the system event log is full. Select Erase Immediately to erase all events in the log when the system event log is full. The options are **Do Nothing** and Erase Immediately.

Note: Reboot the system for the changes to take effect.

► BMC Network Configuration

BMC network configuration

Update IPMI LAN Configuration

Select Yes for the BIOS to implement all IP/MAC address changes at the next system boot. The options are **No** and Yes.

****If the feature above is set to Yes, the Configuration Address Source, VLAN, IPV6 Support, and Configuration Address source features are available for configuration.***

Configure IPV4 support

IPMI LAN Selection

This feature displays the IPMI LAN setting. The default setting is **Failover**.

IPMI Network Link Status

This feature displays the IPMI Network Link status. The default setting is **Dedicated LAN**.

Configuration Address Source

Use this feature to select the source of the IP address for this computer. If Static is selected, you will need to know the IP address of this computer and enter it to the system manually in the field. If DHCP is selected, the BIOS will search for a DHCP (Dynamic Host Configuration Protocol) server in the network that is attached to and request the next available IP address for this computer. The options are **DHCP** and Static.

****If the feature above is set to Static, the Station IP Address/Subnet Mask/Gateway IP Address features are available for configuration:***

Station IP Address

This feature displays the Station IP address for this computer. This should be in decimal and in dotted quad form (i.e., 192.168.10.253).

Subnet Mask

This feature displays the sub-network that this computer belongs to. The value of each three-digit number separated by dots should not exceed 255.

Station MAC Address

This feature displays the Station MAC address for this computer. Mac addresses are 6 two-digit hexadecimal numbers.

Gateway IP Address

This feature displays the Gateway IP address for this computer. This should be in decimal and in dotted quad form (i.e., 192.168.10.253).

VLAN

This feature is configurable if the Update IPMI LAN Configuration feature is set to Yes. Use this feature to enable or disable the IPMI VLAN function. The options are **Disable** and **Enable**.

****If the feature above is set to Enabled, the VLAN ID feature below is available for configuration:***

VLAN ID

Use this feature to select a value for VLAN ID.

Configure IPV6 support**IPV6 Support**

Use this feature to enable IPV6 support. The options are **Enabled** and **Disabled**.

Configuration Address Source

Use this feature to select the source of the IP address for this computer. If Static is selected, you will need to know the IP address of this computer and enter it to the system manually in the field. If DHCP is selected, the BIOS will search for a DHCP (Dynamic Host Configuration Protocol) server in the network that is attached to and request the next available IP address for this computer. The options are **Unspecified**, **Static**, and **DHCP**.

****If the feature above is set to Static, the Station IP Address/Prefix Length/IPV6 Router1 IP Address features are available for configuration:***

Station IPV6 Address

Use this feature to enter the IPV6 address.

Prefix Length

Use this feature to change the prefix length.

IPV6 Router1 IP Address

Use this feature to change the IPV6 Router1 IP address.

IPMI Extended Instruction

Use this feature to enable IPMI extended function support. The options are **Enabled** and **Disabled**. When Disabled, the system powers on quickly by removing BIOS support for

extended IPMI features. The Disable option is for applications that require faster power on time without using Supermicro Update Manager (SUM) or extended IPMI features. The BMC network configuration in the BIOS setup will also be invalid when IPMI Extended Instruction is disabled. The general BMC function and motherboard health monitor such as fan control will still function even when this option is disabled.

6.6 Security

Use this menu to configure the security settings.

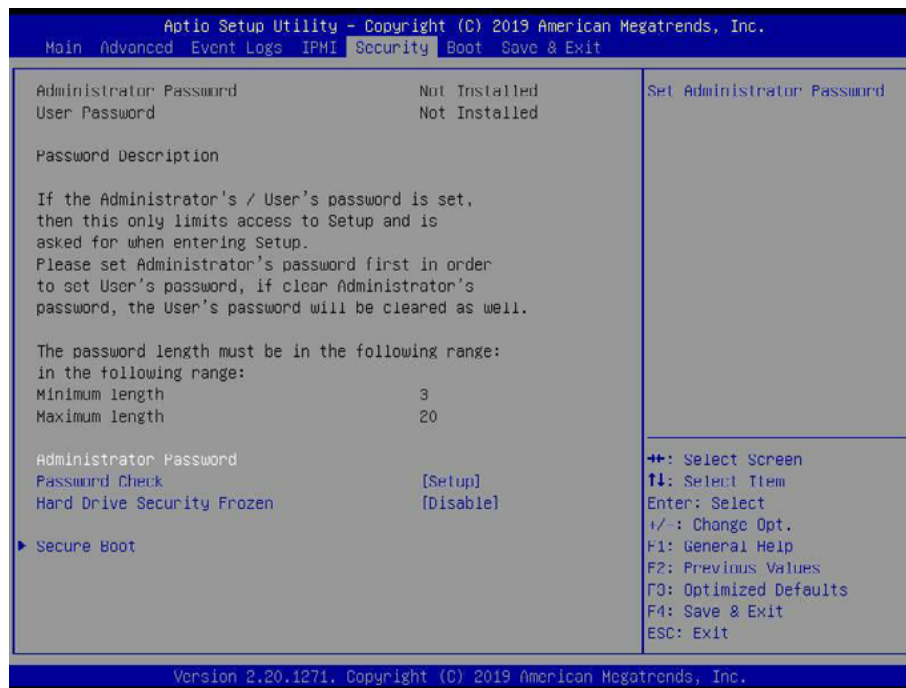

Administrator Password

Use this feature to set the administrator password which is required to enter the BIOS setup utility. The length of the password should be from three to 20 characters long.

Password Check

Select Setup for the system to check for a password at Setup. Select Always for the system to check for a password at boot up or upon entering the BIOS Setup utility. The options are **Setup** and **Always**.

Hard Drive Security Frozen

Use this feature to enable or disable the Security Frozen command to SATA and NVMe devices. The options are **Enable** and **Disable**.

► Secure Boot

System Mode

Secure Boot

Select **Enable** for secure boot support to ensure system security at boot up. The options are **Disabled** and **Enabled**.

Secure Boot Mode

This feature allows you to select the desired secure boot mode for the system. The options are Standard and **Custom**.

****If Secure Boot Mode is set to Custom, Key Management features are available for configuration:***

CSM Support

This feature is for manufacturing debugging purposes.

▶ Key Management

This submenu allows you to configure the following Key Management settings.

Factory Key Provision

Select Enabled to install the default Secure Boot keys set by the manufacturer. The options are **Disabled** and Enabled.

****If the feature above is set to Enabled, all features below are available for configuration:***

▶ Restore Factory Keys

Select Yes to restore all factory keys to the default settings. The options are Yes and No.

▶ Reset to Setup Mode

Select Yes to delete all Secure Boot key databases and force the system to Setup Mode. The options are Yes and No.

▶ Export Secure Boot variables

Use this feature to copy the NVRAM contents of the secure boot variables to a file.

▶ Enroll Efi Image

This feature allows the image to run in Secure Boot mode.

Device Guard Ready

▶ Remove 'UEFI CA' from DB

Use this feature to remove the Microsoft UEFI CA certificate from the database. The options are Yes and No.

▶ Restore DB Defaults

Select Yes to restore the DB defaults.

▶ Platform Key (PK)

Update

Select Yes to load a factory default PK or No to load from a file on an external media.

► Key Exchange Keys (KEK)**Update**

Select Yes to load a factory default KEK or No to load from a file on an external media.

Append

Select Yes to add the KEK from the manufacturer's defaults list to the existing KEK. Select No to load the KEK from a file. The options are Yes and No.

► Authorized Signatures**Update**

Select Yes to load a factory default db or No to load from a file on an external media.

Append

Select Yes to add the db from the manufacturer's defaults list to the existing db. Select No to load the db from a file. The options are Yes and No.

► Forbidden Signatures**Update**

Select Yes to load a factory default dbx or No to load from a file on an external media.

Append

Select Yes to add the dbx from the manufacturer's defaults list to the existing dbx. Select No to load the dbx from a file. The options are Yes and No.

► Authorized TimeStamps**Update**

Select Yes to load a factory default dbt or No to load from a file on an external media.

Append

Select Yes to add the dbt from the manufacturer's defaults list to the existing dbt. Select No to load the dbt from a file. The options are Yes and No.

► OsRecovery Signatures**Update**

Select Yes to load a factory default dbr or No to load from a file on an external media.

Append

Select Yes to add the dbr from the manufacturer's defaults list to the existing dbr. Select No to load the dbr from a file. The options are Yes and No.

6.7 Boot

Use this menu to configure boot settings:

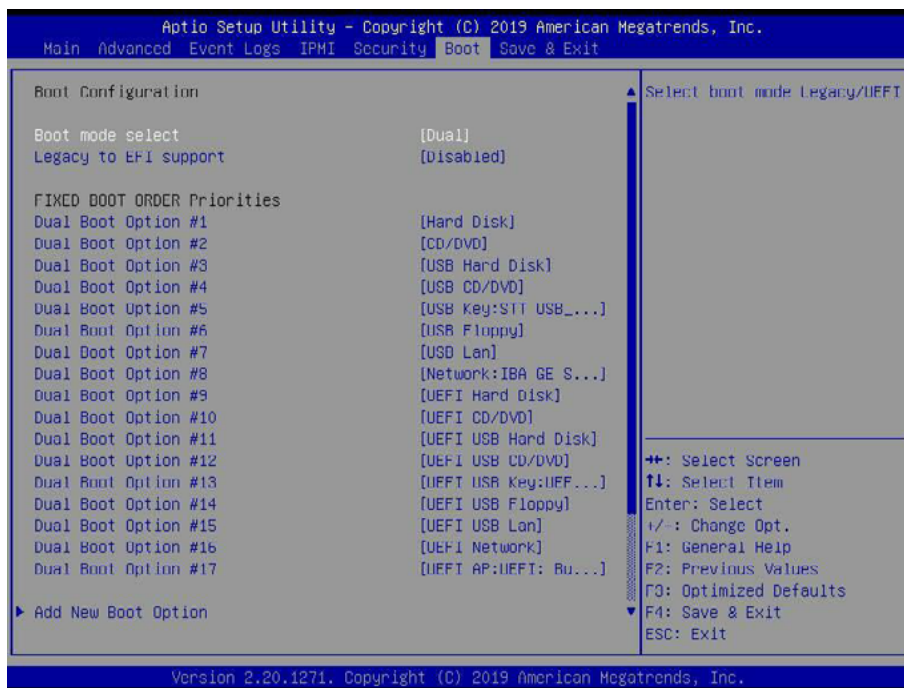

Boot mode select

Use this feature to select the boot mode. The options are Legacy, UEFI, and **Dual**.

Legacy to EFI Support

Select Enabled to boot EFI OS support after Legacy boot order has failed. The options are **Disabled** and Enabled.

Fixed BOOT ORDER Priorities

This option prioritizes the order of bootable devices that the system to boot from. Press <Enter> on each entry from top to bottom to select devices.

- Boot Option #1
- Boot Option #2
- Boot Option #3
- Boot Option #4
- Boot Option #5
- Boot Option #6
- Boot Option #7
- Boot Option #8
- Boot Option #9
- Boot Option #10

- Boot Option #11
- Boot Option #12
- Boot Option #13
- Boot Option #14
- Boot Option #15
- Boot Option #16
- Boot Option #17

Add New Boot Option

Use this feature to add a new boot option to system boot priority features.

▶Delete Boot Option

Use this feature to select a boot device to delete from the boot priority list.

▶UEFI Application Boot Priorities

- Boot Option # - This feature sets the system boot order of detected devices. The options are **[the list of detected boot device(s)]** and Disabled.

▶UEFI USB Key Drive BBS Priorities

This feature is displayed when a storage media is detected.

▶USB Key Drive BBS Priorities

- Boot Option # - This feature sets the system boot order of detected devices. The options are **[the list of detected boot device(s)]** and Disabled.

▶NETWORK Drive BBS Priorities

- Boot Option # - This feature sets the system boot order of detected devices. The options are **[the list of detected boot device(s)]** and Disabled.

6.8 Save & Exit

Use this menu to configure save and exit settings.

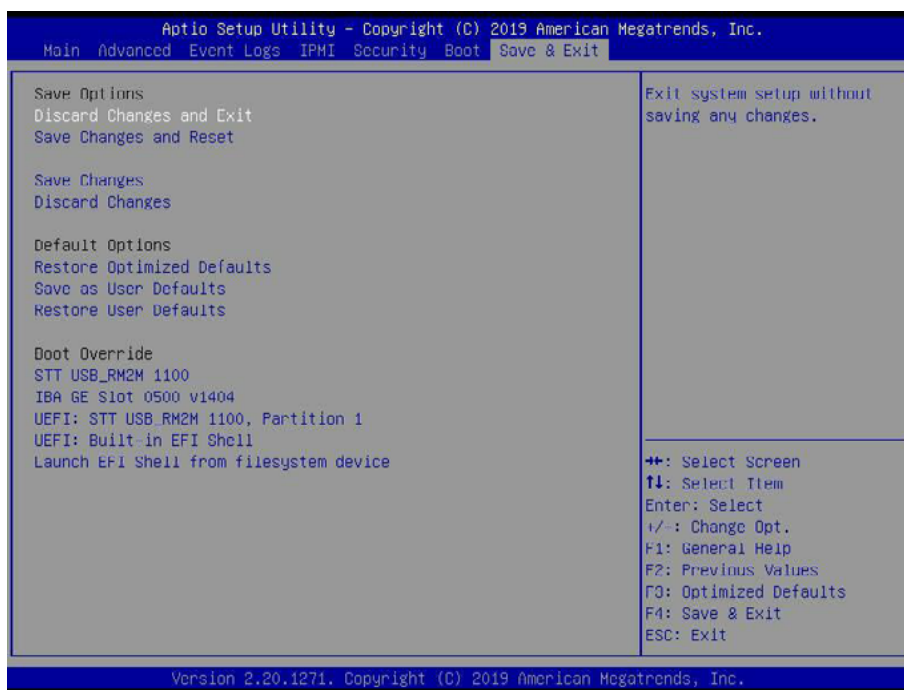

Save Options

Discard Changes and Exit

Select this feature to quit the BIOS Setup without making any permanent changes to the system configuration and reboot the computer. Select Discard Changes and Exit from the Exit menu and press <Enter>.

Save Changes and Reset

When you have completed the system configuration changes, select this option to save all changes made and reset the system.

Save Changes

When you have completed the system configuration changes, select this option to save all changes made. This will not reset (reboot) the system.

Discard Changes

Select this feature and press <Enter> to discard all the changes and return to the AMI BIOS Utility Program.

Default Options

Restore Defaults

To set this feature, select Restore Optimized Defaults and press <Enter>. These are factory settings designed for maximum system performance but not for maximum stability.

Save as User Defaults

To set this feature, select Save as User Defaults from the Exit menu and press <Enter>. This enables the user to save any changes to the BIOS setup for future use.

Restore User Defaults

To set this feature, select Restore User Defaults from the Exit menu and press <Enter>. Use this feature to retrieve user-defined settings that were saved previously.

Boot Override

Other boot options are listed in this section. The system will boot to the selected boot option.

IBA GE Slot 0500 v1404**UEFI: Built-in EFI Shell****Launch EFI Shell from filesystem device**

Appendix A

BIOS Error Codes

A.1 BIOS Error Beep (POST) Codes

During the POST (Power-On Self-Test) routines, which are performed each time the system is powered on, errors may occur.

Non-fatal errors are those which, in most cases, allow the system to continue the boot-up process. The error messages normally appear on the screen.

Fatal errors are those which will not allow the system to continue the boot-up procedure. If a fatal error occurs, you should consult with your system manufacturer for possible repairs.

These fatal errors are usually communicated through a series of audible beeps. The table below lists some common errors and their corresponding beep codes encountered by users.

| BIOS Error Beep (POST) Codes | | |
|------------------------------|---------------------------------|--|
| Beep Code | Error Message | Description |
| 1 short | Refresh | Circuits have been reset (Ready to power up) |
| 5 short, 1 long | Memory error | No memory detected in system |
| 5 long, 2 short | Display memory read/write error | Video adapter missing or with faulty memory |
| 1 long continuous | System OH | System overheat condition |

A.2 Additional BIOS POST Codes

The AMI BIOS supplies additional checkpoint codes, which are documented online at <http://www.supermicro.com/support/manuals/> ("AMI BIOS POST Codes User's Guide").

When BIOS performs the Power On Self Test, it writes checkpoint codes to I/O port 0080h. If the computer cannot complete the boot process, a diagnostic card can be attached to the computer to read I/O port 0080h (Supermicro p/n AOC-LPC80-20).

For information on AMI updates, please refer to <http://www.ami.com/products/>.

Appendix B

Standardized Warning Statements for DC Systems

B.1 About Standardized Warning Statements

The following statements are industry standard warnings, provided to warn the user of situations which have the potential for bodily injury. Should you have questions or experience difficulty, contact Supermicro's Technical Support department for assistance. Only certified technicians should attempt to install or configure components.

Read this appendix in its entirety before installing or configuring components in the Supermicro chassis.

These warnings may also be found on our website at http://www.supermicro.com/about/policies/safety_information.cfm.

Warning Definition



Warning! This warning symbol means danger. You are in a situation that could cause bodily injury. Before you work on any equipment, be aware of the hazards involved with electrical circuitry and be familiar with standard practices for preventing accidents.

警告の定義

この警告サインは危険を意味します。

人身事故につながる可能性がありますので、いずれの機器でも動作させる前に、電気回路に含まれる危険性に注意して、標準的な事故防止策に精通して下さい。

此警告符号代表危險。

您正处于可能受到严重伤害的工作环境中。在您使用设备开始工作之前，必须充分意识到触电的危险，并熟练掌握防止事故发生的标准工作程序。请根据每项警告结尾的声明号码找到此设备的安全性警告说明的翻译文本。

此警告符號代表危險。

您目前所處的工作環境可能讓您受傷。在您使用任何設備之前，請注意觸電的危險，並且要熟悉預防事故發生的標準工作程序。請依照每一注意事項後的號碼找到相關的翻譯說明內容。

Warnung

WICHTIGE SICHERHEITSHINWEISE

Dieses Warnsymbol bedeutet Gefahr. Sie befinden sich in einer Situation, die zu Verletzungen führen kann. Machen Sie sich vor der Arbeit mit Geräten mit den Gefahren elektrischer Schaltungen und den üblichen Verfahren zur Vorbeugung vor Unfällen vertraut. Suchen Sie mit der am Ende jeder Warnung angegebenen Anweisungsnummer nach der jeweiligen Übersetzung in den übersetzten Sicherheitshinweisen, die zusammen mit diesem Gerät ausgeliefert wurden.

BEWAHREN SIE DIESE HINWEISE GUT AUF.

INSTRUCCIONES IMPORTANTES DE SEGURIDAD

Este símbolo de aviso indica peligro. Existe riesgo para su integridad física. Antes de manipular cualquier equipo, considere los riesgos de la corriente eléctrica y familiarícese con los procedimientos estándar de prevención de accidentes. Al final de cada advertencia encontrará el número que le ayudará a encontrar el texto traducido en el apartado de traducciones que acompaña a este dispositivo.

GUARDE ESTAS INSTRUCCIONES.

IMPORTANTES INFORMATIONS DE SÉCURITÉ

Ce symbole d'avertissement indique un danger. Vous vous trouvez dans une situation pouvant entraîner des blessures ou des dommages corporels. Avant de travailler sur un équipement, soyez conscient des dangers liés aux circuits électriques et familiarisez-vous avec les procédures couramment utilisées pour éviter les accidents. Pour prendre connaissance des traductions des avertissements figurant dans les consignes de sécurité traduites qui accompagnent cet appareil, référez-vous au numéro de l'instruction situé à la fin de chaque avertissement.

CONSERVEZ CES INFORMATIONS.

תקנון הצהרות אזהרה

הצהרות הבאות הן אזהרות על פי תקני התעשייה, על מנת להזהיר את המשתמש מפני חבלה

פיזית אפשרית. במידה ויש שאלות או היתקלות בבעיה כלשהי, יש ליצור קשר עם מחלקת תמיכה

טכנית של סופרמיקרו. טכנאים מוסמכים בלבד רשאים להתקין או להגדיר את הרכיבים. יש לקרוא את הנספח במלואו לפני התקנת או הגדרת הרכיבים במארזי סופרמיקרו.

اَكْ ف حالة وُكي اَي تتسبب ف اصابة جسدهُ هذا الزهز عُ خطر! تحذُرُ .
 قبل اَي تعول على اَي هعدات، كي على علن بالوخاطز ال اُجوة عي الذوائر
 الكهزبائِة
 وكي على دراةُ بالووارسات النقاائِة لو عُ وقع اَي حادث
 استخدم رقن الب اِي الو صُص ف هاةُ كل تحذُرُ للعشر تزجوتها

안전을 위한 주의사항

경고!

이 경고 기호는 위험이 있음을 알려 줍니다. 작업자의 신체에 부상을 야기 할 수 있는 상태에 있게 됩니다. 모든 장비에 대한 작업을 수행하기 전에 전기회로와 관련된 위험요소들을 확인하시고 사전에 사고를 방지할 수 있도록 표준 작업절차를 준수해 주시기 바랍니다.

해당 번역문을 찾기 위해 각 경고의 마지막 부분에 제공된 경고문 번호를 참조하십시오

BELANGRIJKE VEILIGHEIDSINSTRUCTIES

Dit waarschuwings symbool betekent gevaar. U verkeert in een situatie die lichamelijk letsel kan veroorzaken. Voordat u aan enige apparatuur gaat werken, dient u zich bewust te zijn van de bij een elektrische installatie betrokken risico's en dient u op de hoogte te zijn van de standaard procedures om ongelukken te voorkomen. Gebruik de nummers aan het eind van elke waarschuwing om deze te herleiden naar de desbetreffende locatie.

BEWAAR DEZE INSTRUCTIES

Installation Instructions



Warning! Read the installation instructions before connecting the system to the power source.

設置手順書

システムを電源に接続する前に、設置手順書をお読み下さい。

警告

将此系统连接电源前,请先阅读安装说明。

警告

將系統與電源連接前，請先閱讀安裝說明。

Warnung

Vor dem Anschließen des Systems an die Stromquelle die Installationsanweisungen lesen.

¡Advertencia!

Lea las instrucciones de instalación antes de conectar el sistema a la red de alimentación.

Attention

Avant de brancher le système sur la source d'alimentation, consulter les directives d'installation.

יש לקרוא את הוראות התקנה לפני חיבור המערכת למקור מתח.

اقرأ إرشادات التركيب قبل توصيل النظام إلى مصدر للطاقة

시스템을 전원에 연결하기 전에 설치 안내를 읽어주십시오.

Waarschuwing

Raadpleeg de installatie-instructies voordat u het systeem op de voedingsbron aansluit.

Circuit Breaker



Warning! This product relies on the building's installation for short-circuit (overcurrent) protection. Ensure that the protective device is rated not greater than: 60VDC, 20A.

サーキット・ブレーカー

この製品は、短絡(過電流)保護装置がある建物での設置を前提としています。

保護装置の定格が60VDC、20Aを超えないことを確認下さい。

警告

此产品的短路(过载电流)保护由建筑物的供电系统提供,确保短路保护设备的额定电流不大于60VDC,20A。

警告

此產品的短路(過載電流)保護由建築物的供電系統提供,確保短路保護設備的額定電流不大於60VDC,20A。

Warnung

Dieses Produkt ist darauf angewiesen, dass im Gebäude ein Kurzschluss- bzw. Überstromschutz installiert ist. Stellen Sie sicher, dass der Nennwert der Schutzvorrichtung nicht mehr als: 60VDC, 20A beträgt.

¡Advertencia!

Este equipo utiliza el sistema de protección contra cortocircuitos (o sobrecorrientes) del edificio. Asegúrese de que el dispositivo de protección no sea superior a: 60VDC, 20A.

Attention

Pour ce qui est de la protection contre les courts-circuits (surtension), ce produit dépend de l'installation électrique du local. Vérifiez que le courant nominal du dispositif de protection n'est pas supérieur à :60VDC, 20A.

מוצר זה מסתמך על הגנה המותקנת במבנים למניעת קצר חשמלי. יש לוודא כי המכשיר המגן מפני הקצר החשמלי הוא לא יותר מ-60VDC, 20A

هذا المنتج يعتمد على معدات الحماية مه الدوائر القصيرة التي تم تثبيتها في المبنى
تأكد من أن تقييم الجهاز الوقائي ليس أكثر من : 20A, 60VDC

경고!

이 제품은 전원의 단락(과전류)방지에 대해서 전적으로 건물의 관련 설비에 의존합니다. 보호장치의 정격이 반드시 60VDC(볼트), 20A(암페어)를 초과하지 않도록 해야 합니다.

Waarschuwing

Dit product is afhankelijk van de kortsluitbeveiliging (overspanning) van uw elektrische installatie. Controleer of het beveiligde apparaat niet groter gedimensioneerd is dan 60VDC, 20A.

Power Disconnection Warning



Warning! The system must be disconnected from all sources of power and the power cord removed from the power supply module(s) before accessing the chassis interior to install or remove system components (except for hot-swap components).

電源切斷の警告

システムコンポーネントの取り付けまたは取り外しのために、シャーシ内部にアクセスするには、システムの電源はすべてのソースから切斷され、電源コードは電源モジュールから取り外す必要があります。

警告

在你打开机箱并安装或移除内部器件前,必须将系统完全断电,并移除电源线。

警告

在您打開機殼安裝或移除內部元件前，必須將系統完全斷電，並移除電源線。

Warnung

Das System muss von allen Quellen der Energie und vom Netzanschlusskabel getrennt sein, das von den Spg.Versorgungsteilmodulen entfernt wird, bevor es auf den Chassisinnenraum zurückgreift, um Systemsbestandteile anzubringen oder zu entfernen.

¡Advertencia!

El sistema debe ser disconnected de todas las fuentes de energía y del cable eléctrico quitado de los módulos de fuente de alimentación antes de tener acceso el interior del chasis para instalar o para quitar componentes de sistema.

Attention

Le système doit être débranché de toutes les sources de puissance ainsi que de son cordon d'alimentation secteur avant d'accéder à l'intérieur du chasis pour installer ou enlever des composants de système.

אזהרה מפני ניתוק חשמלי

אזהרה!

יש לנתק את המערכת מכל מקורות החשמל ויש להסיר את כבל החשמלי מהספק לפני גישה לחלק הפנימי של המארז לצורך התקנת או הסרת רכיבים.

يجب فصل انظاؤ من جميع مصادر انطاقت وإزانت سهك انكهرباء من وحدة امداد
انطاقت قيم
انصل إلى امنطاق انداخييت نههيكم نتشيج أو إزانت مكناث الجهاز

경고!

시스템에 부품들을 장착하거나 제거하기 위해서는 새시 내부에 접근하기 전에 반드시 전원 공급장치로부터 연결되어있는 모든 전원과 전기코드를 분리해주어야 합니다.

Waarschuwing

Voordat u toegang neemt tot het binnenwerk van de behuizing voor het installeren of verwijderen van systeem onderdelen, dient u alle spanningsbronnen en alle stroomkabels aangesloten op de voeding(en) van de behuizing te verwijderen

Equipment Installation



Warning! Only authorized personnel and qualified service persons should be allowed to install, replace, or service this equipment.

機器の設置

トレーニングを受け認定された人だけがこの装置の設置、交換、またはサービスを許可されてい
ます。

警告

只有经过培训且具有资格的人员才能进行此设备的安装、更换和维修。

警告

只有經過受訓且具資格人員才可安裝、更換與維修此設備。

Warnung

Das Installieren, Ersetzen oder Bedienen dieser Ausrüstung sollte nur geschultem, qualifiziertem Personal gestattet werden.

¡Advertencia!

Solamente el personal calificado debe instalar, reemplazar o utilizar este equipo.

Attention

Il est vivement recommandé de confier l'installation, le remplacement et la maintenance de ces équipements à des personnels qualifiés et expérimentés.

אזהרה!

צוות מוסמך בלבד רשאי להתקין, להחליף את הציוד או לתת שירות עבור הציוד.

والمدربيه لتزكيب واستبدال أو خدمة هذا الجهاز يجب أن يسمح فقط للمظفيه المؤهليه

경고!

훈련을 받고 공인된 기술자만이 이 장비의 설치, 교체 또는 서비스를 수행할 수 있습니다.

Waarschuwing

Deze apparatuur mag alleen worden geïnstalleerd, vervangen of hersteld door geschoold en gekwalificeerd personeel.

Restricted Area

Warning! This unit is intended for installation in restricted access areas. A restricted access area can be accessed only through the use of a special tool, lock and key, or other means of security. (This warning does not apply to workstations).

アクセス制限区域

このユニットは、アクセス制限区域に設置されることを想定しています。

アクセス制限区域は、特別なツール、鍵と錠前、その他のセキュリティの手段を用いてのみ出入りが可能です。

警告

此部件应安装在限制进出的场所，限制进出的场所指只能通过使用特殊工具、锁和钥匙或其它安全手段进出的场所。

警告

此装置僅限安裝於進出管制區域，進出管制區域係指僅能以特殊工具、鎖頭及鑰匙或其他安全方式才能進入的區域。

Warnung

Diese Einheit ist zur Installation in Bereichen mit beschränktem Zutritt vorgesehen. Der Zutritt zu derartigen Bereichen ist nur mit einem Spezialwerkzeug, Schloss und Schlüssel oder einer sonstigen Sicherheitsvorkehrung möglich.

¡Advertencia!

Esta unidad ha sido diseñada para instalación en áreas de acceso restringido. Sólo puede obtenerse acceso a una de estas áreas mediante la utilización de una herramienta especial, cerradura con llave u otro medio de seguridad.

Attention

Cet appareil doit être installée dans des zones d'accès réservés. L'accès à une zone d'accès réservé n'est possible qu'en utilisant un outil spécial, un mécanisme de verrouillage et une clé, ou tout autre moyen de sécurité.

אזור עם גישה מוגבלת

אזהרה!

יש להתקין את היחידה באזורים שיש בהם הגבלת גישה. הגישה ניתנת בעזרת 'מפתח, מנעול וכד' (כלי אבטחה בלבד).

تخصيص هذه انحدة نترك بُها ف مناطق محظورة تم .
ممكن اننصل إن منطقت محظورة فقط من خلال استخدام أداة خاصت
أو أوس هُت أخري نلالأما ققم ومفتاح

경고!

이 장치는 접근이 제한된 구역에 설치하도록 되어있습니다. 특수도구, 잠금 장치 및 키, 또는 기타 보안 수단을 통해서만 접근 제한 구역에 들어갈 수 있습니다.

Waarschuwing

Dit apparaat is bedoeld voor installatie in gebieden met een beperkte toegang. Toegang tot dergelijke gebieden kunnen alleen verkregen worden door gebruik te maken van speciaal gereedschap, slot en sleutel of andere veiligheidsmaatregelen.

Battery Handling



Warning! There is the danger of explosion if the battery is replaced incorrectly. Replace the battery only with the same or equivalent type recommended by the manufacturer. Dispose of used batteries according to the manufacturer's instructions

電池の取り扱い

電池交換が正しく行われなかった場合、破裂の危険性があります。交換する電池はメーカーが推奨する型、または同等のものを使用下さい。使用済電池は製造元の指示に従って処分して下さい。

警告

電池更換不當會有爆炸危險。請只使用同類電池或制造商推薦的功能相當的電池更換原有電池。請按製造商的說明處理廢舊電池。

警告

電池更換不當會有爆炸危險。請使用製造商建議之相同或功能相當的電池更換原有電池。請按照製造商的說明指示處理廢棄舊電池。

Warnung

Bei Einsetzen einer falschen Batterie besteht Explosionsgefahr. Ersetzen Sie die Batterie nur durch den gleichen oder vom Hersteller empfohlenen Batterietyp. Entsorgen Sie die benutzten Batterien nach den Anweisungen des Herstellers.

Attention

Danger d'explosion si la pile n'est pas remplacée correctement. Ne la remplacer que par une pile de type semblable ou équivalent, recommandée par le fabricant. Jeter les piles usagées conformément aux instructions du fabricant.

¡Advertencia!

Existe peligro de explosión si la batería se reemplaza de manera incorrecta. Reemplazar la batería exclusivamente con el mismo tipo o el equivalente recomendado por el fabricante. Desechar las baterías gastadas según las instrucciones del fabricante.

אזהרה!

קיימת סכנת פיצוץ של הסוללה במידה והוחלפה בדרך לא תקינה. יש להחליף את הסוללה בסוג התואם מחברת יצרן מומלצת. סילוק הסוללות המשומשות יש לבצע לפי הוראות היצרן.

هناك خطر من انفجار في حالة اسبدال البطارية بطريقة غير صحيحة فعلى
اسبدال البطارية
فقط بنفس النوع أو ما يعادلها مما أوصت به الشركة المصنعة
جخلص من البطاريات المسحومة وفقا لعمليات الشركة الصانعة

경고!

배터리가 올바르게 교체되지 않으면 폭발의 위험이 있습니다. 기존 배터리와 동일하거나 제조사에서 권장하는 동등한 종류의 배터리로만 교체해야 합니다. 제조사의 안내에 따라 사용된 배터리를 처리하여 주십시오.

Waarschuwing

Er is ontplofingsgevaar indien de batterij verkeerd vervangen wordt. Vervang de batterij slechts met hetzelfde of een equivalent type die door de fabrikant aanbevolen wordt. Gebruikte batterijen dienen overeenkomstig fabrieksvoorschriften afgevoerd te worden.

Redundant Power Supplies



Warning! This unit might have more than one power supply connection. All connections must be removed to de-energize the unit.

冗長電源装置

このユニットは複数の電源装置が接続されている場合があります。

ユニットの電源を切るためには、すべての接続を取り外さなければなりません。

警告

此部件连接的电源可能不止一个，必须将所有电源断开才能停止给该部件供电。

警告

此装置连接的电源可能不只一个，必须切断所有电源才能停止对该装置的供电。

Warnung

Dieses Gerät kann mehr als eine Stromzufuhr haben. Um sicherzustellen, dass der Einheit kein Strom zugeführt wird, müssen alle Verbindungen entfernt werden.

¡Advertencia!

Puede que esta unidad tenga más de una conexión para fuentes de alimentación. Para cortar por completo el suministro de energía, deben desconectarse todas las conexiones.

Attention

Cette unité peut avoir plus d'une connexion d'alimentation. Pour supprimer toute tension et tout courant électrique de l'unité, toutes les connexions d'alimentation doivent être débranchées.

אם קיים יותר מספק אחד

אזהרה!

ליחידה יש יותר מחיבור אחד של ספק. יש להסיר את כל החיבורים על מנת לרוקן את היחידה.

قد يكون لهذا الجهاز عدة اتصالات بوحدات امداد الطاقة .
يجب إزالة كافة الاتصالات لعسل الوحدة عن الكهرباء

경고!

이 장치에는 한 개 이상의 전원 공급 단자가 연결되어 있을 수 있습니다. 이 장치에 전원을 차단하기 위해서는 모든 연결 단자를 제거해야만 합니다.

Waarschuwing

Deze eenheid kan meer dan één stroomtoevoeraansluiting bevatten. Alle aansluitingen dienen verwijderd te worden om het apparaat stroomloos te maken.

Backplane Voltage



Warning! Hazardous voltage or energy is present on the backplane when the system is operating. Use caution when servicing.

バックプレーンの電圧

システムの稼働中は危険な電圧または電力が、バックプレーン上にかかっています。

修理する際には注意ください。

警告

当システム正在进行时，背板上有很危险的电压或能量，进行维修时务必小心。

警告

當系統正在進行時，背板上危險的電壓或能量，進行維修時務必小心。

Warnung

Wenn das System in Betrieb ist, treten auf der Rückwandplatine gefährliche Spannungen oder Energien auf. Vorsicht bei der Wartung.

¡Advertencia!

Cuando el sistema está en funcionamiento, el voltaje del plano trasero es peligroso. Tenga cuidado cuando lo revise.

Attention

Lorsque le système est en fonctionnement, des tensions électriques circulent sur le fond de panier. Prendre des précautions lors de la maintenance.

מתח בפנל האחורי

אזהרה!

קיימת סכנת מתח בפנל האחורי בזמן תפעול המערכת. יש להיזהר במהלך העבודה.

هناك خطر من التيار الكهربائي أو الطاقة المتجددة على اللوحة
عندما يكون النظام يعمل كه حذرا عند خدمة هذا الجهاز

경고!

시스템이 동작 중일 때 후면판 (Backplane)에는 위험한 전압이나 에너지가 발생 합니다.
서비스 작업 시 주의하십시오.

Waarschuwing

Een gevaarlijke spanning of energie is aanwezig op de backplane wanneer het systeem in gebruik is. Voorzichtigheid is geboden tijdens het onderhoud.

Comply with Local and National Electrical Codes



Warning! Installation of the equipment must comply with local and national electrical codes.

地方および国の電気規格に準拠

機器の取り付けはその地方および国の電気規格に準拠する必要があります。

警告

设备安装必须符合本地与本国电气法规。

警告

設備安裝必須符合本地與本國電氣法規。

Warnung

Die Installation der Geräte muss den Sicherheitsstandards entsprechen.

¡Advertencia!

La instalacion del equipo debe cumplir con las normas de electricidad locales y nacionales.

Attention

L'équipement doit être installé conformément aux normes électriques nationales et locales.

תיאום חוקי החשמל הארצי
אזהרה!
התקנת הציוד חייבת להיות תואמת לחוקי החשמל המקומיים והארציים.

تركيب المعدات الكهربائية يجب أن يمتثل للقوايه المحلية والبطية المتعلقة
بالكهرباء

경고!

현 지역 및 국가의 전기 규정에 따라 장비를 설치해야 합니다.

Waarschuwing

Bij installatie van de apparatuur moet worden voldaan aan de lokale en nationale elektriciteitsvoorschriften.

Product Disposal



Warning! Ultimate disposal of this product should be handled according to all national laws and regulations.

製品の廃棄

この製品を廃棄処分する場合、国の関係する全ての法律・条例に従い処理する必要があります。

警告

本产品的废弃处理应根据所有国家的法律和规章进行。

警告

本產品的廢棄處理應根據所有國家的法律和規章進行。

Warnung

Die Entsorgung dieses Produkts sollte gemäß allen Bestimmungen und Gesetzen des Landes erfolgen.

¡Advertencia!

Al deshacerse por completo de este producto debe seguir todas las leyes y reglamentos nacionales.

Attention

La mise au rebut ou le recyclage de ce produit sont généralement soumis à des lois et/ou directives de respect de l'environnement. Renseignez-vous auprès de l'organisme compétent.

סילוק המוצר

אזהרה!

סילוק סופי של מוצר זה חייב להיות בהתאם להנחיות וחוקי המדינה.

التخلص النهائي من هذا المنتج ينبغي التعامل معه وفقا لجميع القوانين واللوائح الوطنية عند

경고!

이 제품은 해당 국가의 관련 법규 및 규정에 따라 폐기되어야 합니다.

Waarschuwing

De uiteindelijke verwijdering van dit product dient te geschieden in overeenstemming met alle nationale wetten en reglementen.

Fan Warning



Warning! Hazardous moving parts. Keep away from moving fan blades. The fans might still be turning when you remove the fan assembly from the chassis. Keep fingers, screwdrivers, and other objects away from the openings in the fan assembly's housing.

ファン・ホットスワップの警告

警告!回転部品に注意。運転中は回転部(羽根)に触れないでください。シャーシから冷却ファン装置を取り外した際、ファンがまだ回転している可能性があります。ファンの開口部に、指、ドライバー、およびその他のものを近づけないで下さい。

警告!

警告! 危險的可移動性零件。請務必與轉動的风扇叶片保持距離。當您從機架移除風扇裝置，風扇可能仍在轉動。小心不要將手指、螺絲起子和其他物品太靠近風扇

警告

危險的可移動性零件。請務必與轉動的风扇叶片保持距離。當您從機架移除風扇裝置，風扇可能仍在轉動。小心不要將手指、螺絲起子和其他物品太靠近風扇。

Warnung

Gefährlich Bewegende Teile. Von den bewegenden Lüfterblätter fern halten. Die Lüfter drehen sich u. U. noch, wenn die Lüfterbaugruppe aus dem Chassis genommen wird. Halten Sie Finger, Schraubendreher und andere Gegenstände von den Öffnungen des Lüftergehäuses entfernt.

¡Advertencia!

Riesgo de piezas móviles. Mantener alejado de las aspas del ventilador. Los ventiladores podran dar vuelta cuando usted quite el montaje del ventilador del chasis. Mantenga los dedos, los destornilladores y todos los objetos lejos de las aberturas del ventilador

Attention

Pieces mobiles dangereuses. Se tenir a l'écart des lames du ventilateur Il est possible que les ventilateurs soient toujours en rotation lorsque vous retirerez le bloc ventilateur du châssis. Prenez garde à ce que doigts, tournevis et autres objets soient éloignés du logement du bloc ventilateur.

אזהרה!

חלקים נעים מסוכנים. התרחק מלהבי המאוורר בפעולה כאשר מסירים את חלקי המאוורר מהמארז, יתכן והמאווררים עדיין עובדים. יש להרחיק למרחק בטוח את האצבעות וכלי עבודה שונים מהפתחים בתוך המאוורר

تحذير! أجزاء متحركة خطيرة. ابتعد عن شفرات المروحة المتحركة. من الممكن أن المراوح لا تزال تدور عند إزالة كتلة المروحة من الهيكل يجب إبقاء الأصابع ومفكات البراغي وغيرها من الأشياء بعيدا عن الفتحات في كتلة المروحة

경고!

움직이는 위험한 부품. 회전하는 송풍 날개에 접근하지 마세요. 새시로부터 팬 조립품을 제거할 때 팬은 여전히 회전하고 있을 수 있습니다. 팬 조립품 외관의 열려있는 부분들로부터 손가락 및 스크류드라이버, 다른 물체들이 가까이 하지 않도록 배치해 주십시오.

Waarschuwing

Gevaarlijk bewegende onderdelen. Houd voldoende afstand tot de bewegende ventilatorbladen. Het is mogelijk dat de ventilator nog draait tijdens het verwijderen van het ventilatorsamenstel uit het chassis. Houd uw vingers, schroevendraaiers en eventuele andere voorwerpen uit de buurt van de openingen in de ventilatorbehuizing.

DC Power Supply



Warning! When stranded wiring is required, use approved wiring terminations, such as closedloop or spade-type with upturned lugs. These terminations should be the appropriate size for the wires and should clamp both the insulation and conductor.

警告

より線が必要な場合、承認済みのケーブル終端(上向きの端子を備えたクローズループ型またはU字型の終端など)を使用してください。使用するワイヤーに適したサイズで、絶縁体および導体が両方ともクランプされている終端でなければなりません。

警告

需要多股佈線時，請使用經核准的佈線終端，例如閉環或鏟型接線片。這些終端的大小應適合線路，並且可以同時夾住絕緣體和導體。

警告

需要使用绞线连接时，请使用经认可的连接端子，如闭环端子或具有接线柱的铲形端子。这些端子的大小应与线缆相吻合，并且可以将绝缘部分和导体夹紧固定。

Warnung

Wenn Litzenverdrahtung erforderlich ist, sind zugelassene Verdrahtungsabschlüsse, z.B. für einen geschlossenen Regelkreis oder gabelförmig, mit nach oben gerichteten Kabelschuhen zu verwenden. Diese Abschlüsse sollten die angemessene Größe für die Drähte haben und sowohl die Isolierung als auch den Leiter festklemmen.

¡Advertencia!

Cuando se necesite hilo trenzado, utilizar terminales para cables homologados, tales como las de tipo "bucle cerrado" o "espada", con las lengüetas de conexión vueltas hacia arriba. Estos terminales deberán ser del tamaño apropiado para los cables que se utilicen, y tendrán que sujetar tanto el aislante como el conductor.

Attention

Quand des fils torsadés sont nécessaires, utiliser des douilles terminales homologuées telles que celles à circuit fermé ou du type à plage ouverte avec cosses rebroussées. Ces douilles terminales doivent être de la taille qui convient aux fils et doivent être refermées sur la gaine isolante et sur le conducteur.

תקנון הזהרות אזהרה

הזהרות הבאות הן אזהרות על פי תקני התעשייה, על מנת להזהיר את המשתמש מפני חבלה פיזית אפשרית. במידה ויש שאלות או היתקלות בבעיה כלשהי, יש ליצור קשר עם מחלקת תמיכה טכנית של סופרמיקרו. טכנאים מוסמכים בלבד רשאים להתקין או להגדיר את הרכיבים.

יש לקרוא את הנספח במלואו לפני התקנת או הגדרת הרכיבים במארזי סופרמיקרו.

تحذير

وأقول غم قق ل ح لشم ،اهي ل ع قق ف او مل اء ان! كال سأل ا ماد خ ت س او ،ل بس ل ا م ه ب ت ع ط ق ت ن ي ذل ا كال سأل ا ب و ل ط م ن و ك ي ا م د ن ع ب ج ي و كال سأل ا ل بس ان مل ا م ج ح ل ا ن و ك ي ت اء اء ان ال ا ه ذ ل ي غ ب ن ي و . ة ب و ل ق م ت ا و ر ع ل ا ع م ع و ن ل ا ة ي ق ي ق ح ل ا ا ه ي ا م س أ ب ا ي ش أ ل ا ل ص و م و ل ز ع ل ا ن م ل ك ح ب ك .

주의!

꼬인 배선이 요구 될 때에는 폐회로나 돌출부가 위로 튀어 나온 Spade 형태의 승인된 배선 터미네이션들을 사용하세요.

이 터미네이션들은 배선들을 위해 적절한 크기여야 하고, 절연체와 도체 모두를 고정시킬 수 있어야 합니다.

Waarschuwing

Wanneer geslagen bedrading vereist is, dient u bedrading te gebruiken die voorzien is van goedgekeurde aansluitingspunten, zoals het gesloten-lus type of het grijperschop type waarbij de aansluitpunten omhoog wijzen. Deze aansluitpunten dienen de juiste maat voor de draden te hebben en dienen zowel de isolatie als de geleider vast te klemmen.

DC Power Disconnection



Warning! Before performing any of the following procedures, ensure that power is removed from the DC circuit.

警告

次の手順を開始する前に、DC回路から電源が切断されていることを確認してください。

警告

進行以下任一操作程序前，請確保直流電路已斷電。

警告

请在进行以下任一操作程序前，确保直流电路的电源已经断开。

Warnung

Vor Ausführung der folgenden Vorgänge ist sicherzustellen, daß die Gleichstromschaltung keinen Strom erhält.

¡Advertencia!

Antes de proceder con los siguientes pasos, comprobar que la alimentación del circuito de corriente continua (CC) esté cortada (OFF).

Attention

Avant de pratiquer l'une quelconque des procédures ci-dessous, vérifier que le circuit en courant continu n'est plus sous tension.

אזהרה!
לפני ביצוע אחת הפעולות הבאות, ודא כי אספקת החשמל למעגל הזרם הישר
DC הינה מנותקת.

تحذير

وأقول غم قتل ح لشم، ادهي لع قق فاومل اءاهن! كالسأل مادختساو، لبسلا مدهب تعطقت نيذلا كالسأل ابولطم نوكي امدن ع
 بجي وكالسلل بسانملا مچحل نوكي تاءاهن إل اذهل يغبنني و. ةبولقم تاورعل عم عونلا ةيقي قحلا ادهي امس أب اءيشأل
 لصوصم و لزعل نم لك حبك

주의!

다음 절차들을 수행하기 전에, 전원이 DC 회로로부터 제거되었는지를 확인해 주십시오.

Waarschuwing

Wanneer geslagen bedrading vereist is, dient u bedrading te gebruiken die voorzien is van goedgekeurde aansluitingspunten, zoals het gesloten-lus type of het grijperschop type waarbij de aansluitpunten omhoog wijzen. Deze aansluitpunten dienen de juiste maat voor de draden te hebben en dienen zowel de isolatie als de geleider vast te klemmen.

Hazardous Voltage or Energy Present on DC Power Terminals



Warning! Hazardous voltage or energy may be present on DC power terminals. Always replace cover when terminals are not in service. Be sure uninsulated conductors are not accessible when cover is in place.

警告

直接電力端子に危険な電圧やエネルギーが発生している可能性があります。使用していない端子には常にカバーをつけてください。カバーがついているときは非絶縁形コンダクターに接触していないことを確認してください。

警告

直流電源終端可能產生危險的電壓或能量。終端不使用時，請務必蓋上機蓋。當蓋上機蓋，確認不絕緣導體無法使用。

警告

直流电源终端可能会产生危险的电压或能量。终端不使用时，请务必盖上机盖。机盖盖上后，请确保导体未绝缘部分无法使用。

Warnung

In mit Gleichstrom betriebenen Terminals kann es zu gefährlicher Spannung kommen. Die Terminals müssen abgedeckt werden, wenn sie nicht in Betrieb sind. Stellen Sie bei Benutzung der Abdeckung sicher, dass alle nicht isolierten, stromführenden Kabel abgedeckt sind.

¡Advertencia!

Puede haber energía o voltaje peligrosos en los terminales eléctricos de CC. Reemplace siempre la cubierta cuando no estén utilizándose los terminales. Asegúrese de que no haya acceso a conductores descubiertos cuando la cubierta esté colocada.

Attention

Le voltage ou l'énergie électrique des terminaux à courant continu peuvent être dangereux. Veillez à toujours replacer le couvercle lors les terminaux ne sont pas en service. Assurez-vous que les conducteurs non isolés ne sont pas accessibles lorsque le couvercle est en place.

אזהרה!

מקור מתח מסוכן עלול להיות נוכח על הקטבים של זרם ה-DC. החלף תמיד את המכסה כאשר הקטבים לא בשימוש. ודא כי המוליכים הלא מבודדים אינם נגישים כאשר המכסה נמצא במקומו.

تحذير

امدنع امئاد ءاطغ لادبتسا . ءمصاعل ءق اظلا تا طحم ىلع ءدوجوم نوكت ءق اظلا و ا ءرطخل دهجل دق
ءاطغلا امدنع اه ل ل لوصول انكم ي ال لوزعم ريغ تالصومل ه ي ف كش ال امم . ءمدخل ا ي ف تسيل تا طحمل
هنكم ي ف .

주의!

DC전원 단자들에 위험한 전압이나 에너지가 발생할 수 있습니다.

단말기들을 운영하지 않을 때에는 덮개로 다시 덮어 놓아 주십시오. 덮개가 제자리에 있어야만 절연되지 않은 도체들의 접근을 막을 수 있습니다.

Waarschuwing

Op DC-aansluitingspunten kunnen zich gevaarlijke voltages of energieën voordoen. Plaats altijd de afsluiting wanneer de aansluitingspunten niet worden gebruikt. Zorg ervoor dat blootliggende contactpunten niet toegankelijk zijn wanneer de afsluiting is geplaatst.

Appendix C

System Specifications

Processors

E403-9D-16C-IPD2: Single Intel® Xeon® D-2183IT

E403-9D-14CN-IPD2: Single Intel® Xeon® D-2177NT

Note: Refer to the motherboard specifications page on our website for updates to supported processors.

BIOS

512Mb AMI BIOS® SPI Flash BIOS

Plug and Play (PnP), ACPI 6.1, BIOS rescue hot-key, SMBIOS 2.8/3.1, PCI F/W 3.2 RTC Wakeup, UEFI 2.7

Memory

Supports up to 256GB of ECC RDIMM or 512GB of ECC LRDIMM DDR4-2400 memory in four DIMM slots

Storage Drives

Four internal SATA3 2.5" drive bays

Expansion Slots

Two PCIe 3.0 x16 or two PCIe 3.0 x8 + one PCIe 3.0 x16 (FHFL) slots

One M.2 M-Key 2280/22110

One M.2 B-Key 3042

One M.2 E-Key 2230

Input/Output

Four SATA3 (6Gbps) ports supporting RAID 0, 1, 5, 10

USB: two USB 3.0 ports, two USB 2.0 ports

Serial Port: one COM via RJ45

Video: one VGA port

Network

Nine RJ45 10GbE LAN ports, four 10G SFP+ LAN ports, one RJ45 dedicated IPMI LAN port

Motherboard

E403-9D-16C-IPD2: X11SDW-16C-TP13F+

E403-9D-14CN-IPD2: X11SDW-14CN-TP13F+

Dimensions: 8" x 10" (203.2 mm x 254 mm)

Enclosure

B403-IP65; (WxHxD) 12.56 x 32.31 x 10.16 in. (319 x 821 x 258 mm)

System Cooling

Three 80 x 80-mm chassis fans, three 80 x 80-mm waterproof enclosure fans

Server Power Supply

Model: PWS-601D-1R, 600W DC multi-output power supply with PFC; 92%+ efficiency

DC Voltage (terminal block input connector)

-44VDC to -65VDC

+5V standby: 3A

+12V: 50A

Server Power

-44VDC to 59VDC, 900W maximum

Operating Environment

Operating Temperature: -40°C to 46°C (-40°F to 114.8°F) + solar load

Non-operating Temperature: -40°C to 85°C (-40°F to 185°F)

Operating Relative Humidity: 8% to 90% (non-condensing)

Non-operating Relative Humidity: 5% to 95% (non-condensing)

Regulatory Compliance

FCC, ICES, CE, VCCI, RCM, UKCA, NRTL, CB

Applied Directives, Standards

EMC/EMI: 2014/30/EU (EMC Directive)

Electromagnetic Compatibility Regulations 2016

FCC Part 15 Subpart B

ICES-003

VCCI-CISPR 32

AS/NZS CISPR 32

EN/BS EN 55024

EN/BS EN 55032

EN/BS EN 55035

EN/BS 61000-3-2

EN/BS 61000-3-3

EN/BS 61000-4-2

EN/BS 61000-4-3

EN/BS 61000-4-4

EN/BS 61000-4-5

EN/BS 61000-4-6

EN/BS 61000-4-8

EN/BS 61000-4-11

EN/BS EN 61000-6-2

EN/BS EN 61000-6-4

Green Environment:

2011/65/EU (RoHS Directive)

EC 1907/2006 (REACH)

2012/19/EU (WEEE Directive)

Product Safety: 2014/35/EU (LVD Directive)

Electrical Equipment (Safety) Regulations 2016

UL/CSA 62368-1 (USA and Canada)

IEC/EN 62368-1

Perchlorate Warning

California Best Management Practices Regulations for Perchlorate Materials: This Perchlorate warning applies only to products containing CR (Manganese Dioxide) Lithium coin cells. "Perchlorate Material-special handling may apply. See www.dtsc.ca.gov/hazardouswaste/perchlorate"

この装置は、クラスA機器です。この装置を住宅環境で使用すると電波妨害を引き起こすことがあります。この場合には使用者が適切な対策を講ずるよう要求されることがあります。

VCCI - A

Appendix D

UEFI BIOS Recovery Instructions

Warning: Do not upgrade the BIOS unless your system has a BIOS-related issue. Flashing the wrong BIOS can cause irreparable damage to the system. In no event shall Supermicro be liable for direct, indirect, special, incidental, or consequential damages arising from a BIOS update. If you need to update the BIOS, do not shut down or reset the system while the BIOS is updating to avoid possible boot failure.

D.1 An Overview to the UEFI BIOS

The Unified Extensible Firmware Interface (UEFI) provides a software-based interface between the operating system and the platform firmware in the pre-boot environment. The UEFI specification supports an architecture-independent mechanism for add-on card initialization to allow the UEFI OS loader, which is stored in the add-on card, to boot the system. The UEFI offers a clean, hands-off control to a computer system at bootup.

D.2 How to Recover the UEFI BIOS Image (-the Main BIOS Block)

A UEFI BIOS flash chip consists of a recovery BIOS block and a main BIOS block (a main BIOS image). The boot block contains critical BIOS codes, including memory detection and recovery codes for the user to flash a new BIOS image if the original main BIOS image is corrupted. When the system power is on, the boot block codes execute first. Once it is completed, the main BIOS code will continue with system initialization and bootup.

Note: Follow the BIOS recovery instructions below for BIOS recovery when the main BIOS boot crashes. However, when the BIOS boot block crashes, you will need to follow the procedures below for BIOS recovery.

D.3 To Recover the Main BIOS Block Using a USB-Attached Device

This feature allows the user to recover a BIOS image using a USB-attached device without additional utilities used. A USB flash device, such as a USB flash drive or a USB CD/DVD ROM/RW device, can be used for this purpose. However, a USB hard disk drive cannot be used for BIOS recovery at this time.

The file system supported by UEFI is FAT (including FAT12, FAT16, and FAT32) installed on a bootable or non-bootable USB-attached device. However, the BIOS might need several minutes to locate the SUPER.ROM file if the media size becomes too large because it contains too many folders and files.

To perform UEFI BIOS recovery using a USB-attached device, follow the instructions below.

1. Using a different machine, copy the "Super.ROM" binary image file into the disc Root "\\" Directory of a USB device or a writeable CD/DVD.

Note: If you cannot locate the "Super.ROM" file in your driver disk, visit our website at www.supermicro.com to download the BIOS image into a USB flash device and rename it "Super.ROM" for BIOS recovery use.

2. Insert the USB device that contains the new BIOS image ("Super.ROM") into your USB drive and power on the system
3. While powering on the system, please keep pressing <Ctrl> and <Home> simultaneously on your keyboard until the following screen (or a screen similar to the one below) displays.

Caution: Please **stop** pressing the <Ctrl> and <Home> keys immediately when you see the screen (or a similar screen) below; otherwise, it will trigger a system reboot.



Note: On the other hand, if the following screen displays, please load the "Super.ROM" file to the root folder and connect this folder to the system. (You can do so by inserting a USB device that contains the new "Super.ROM" image to your machine for BIOS recovery.)



4. After locating the new BIOS binary image, the system will enter the BIOS Recovery menu as shown below.

Note: At this point, you may decide if you want to start with BIOS recovery. If you decide to proceed with BIOS recovery, follow the procedures below.

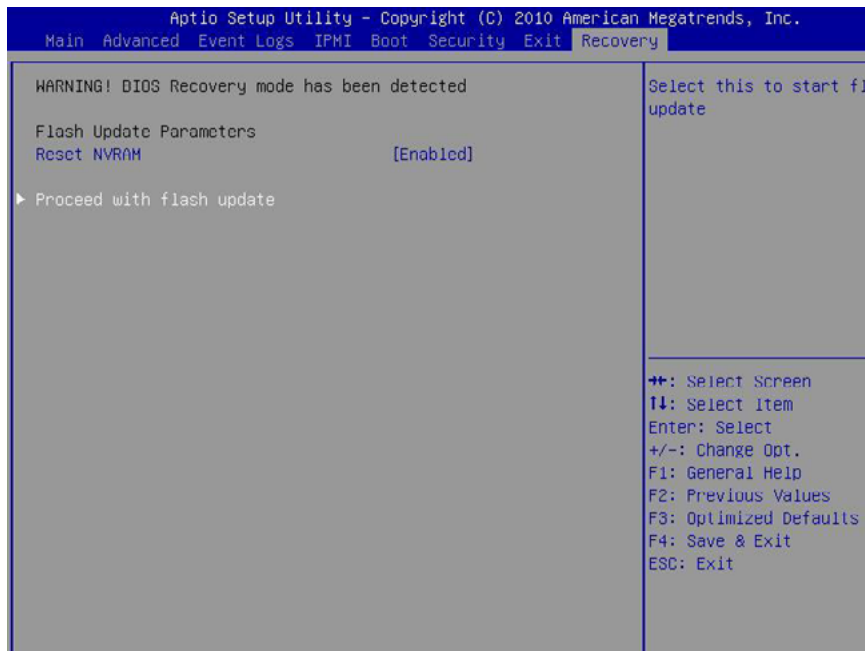

5. When the screen as shown above displays, use the arrow key to select the item "Proceed with flash update" and press the <Enter> key. You will see the progress of BIOS recovery as shown in the screen below.

Note: Do not interrupt the process of BIOS flashing until it is completed.

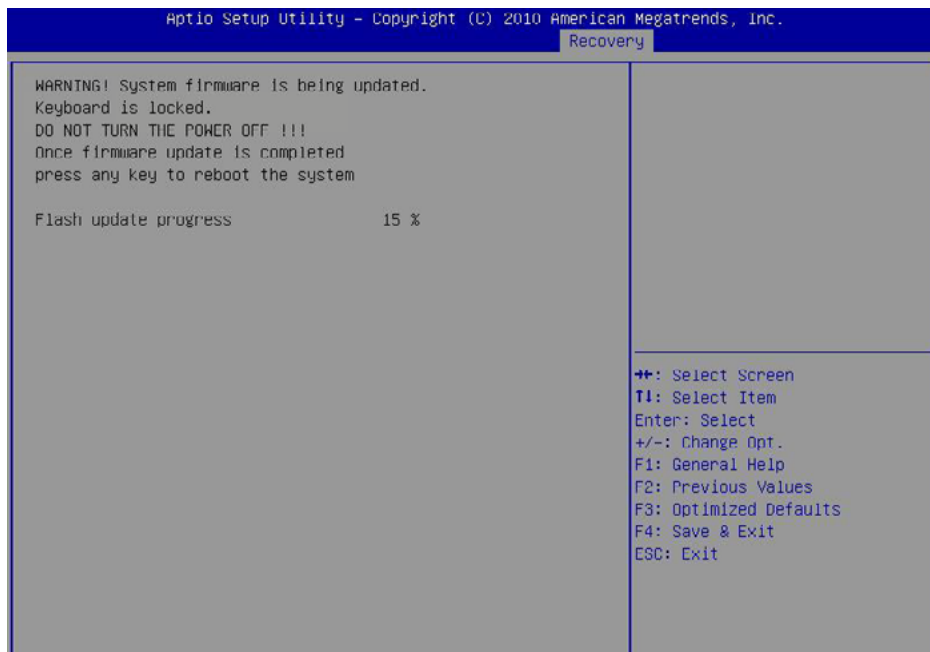

6. After the process of BIOS recovery is completed, press any key to reboot the system.

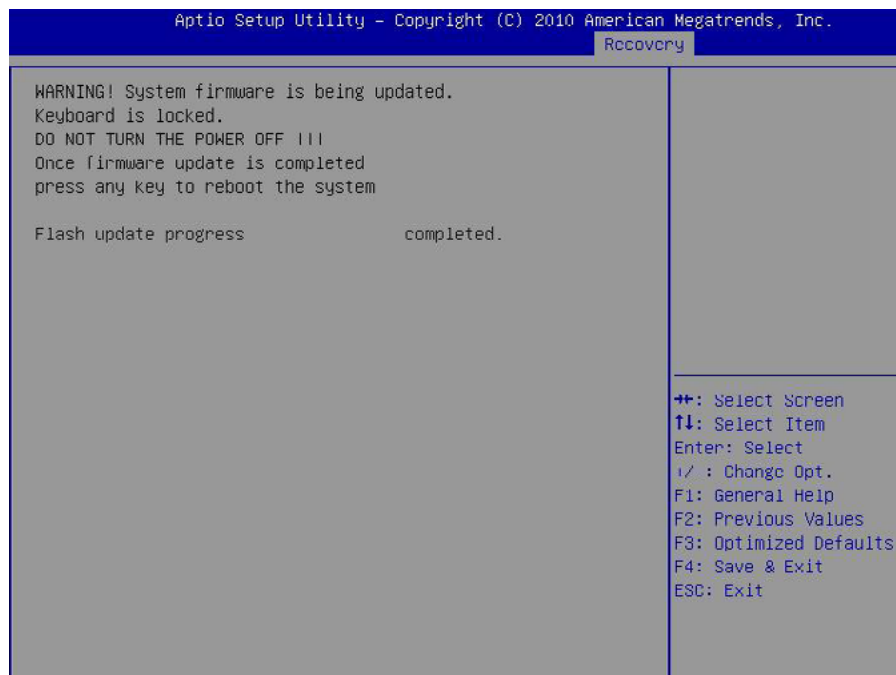

7. Using a different system, extract the BIOS package into a bootable USB flash drive.
8. When a DOS prompt appears, enter `FLASH.BAT BIOSname.###` at the prompt.
Note: *Do not interrupt this process* until BIOS flashing is completed.
9. After seeing the message that the BIOS update is complete, unplug the AC power cable from the power supply to clear the CMOS, and then plug the AC power cable in the power supply again to power on the system.
10. Press continuously to enter the BIOS Setup utility.
11. Press <F3> to load default settings.
12. After loading default settings, press <F4> to save the settings and exit the BIOS Setup utility.

Appendix E

IPMI Crash Dump

In the event of a processor internal error (IERR) that crashes your system, you may want to provide information to support staff. You can download a crash dump of status information using IPMI. The IPMI manual is available at <https://www.supermicro.com/solutions/IPMI.cfm>.

Check IPMI Error Log

1. Access the IPMI web interface.
2. Click the **Server Health** tab, then **Event Log** to verify an IERR error.

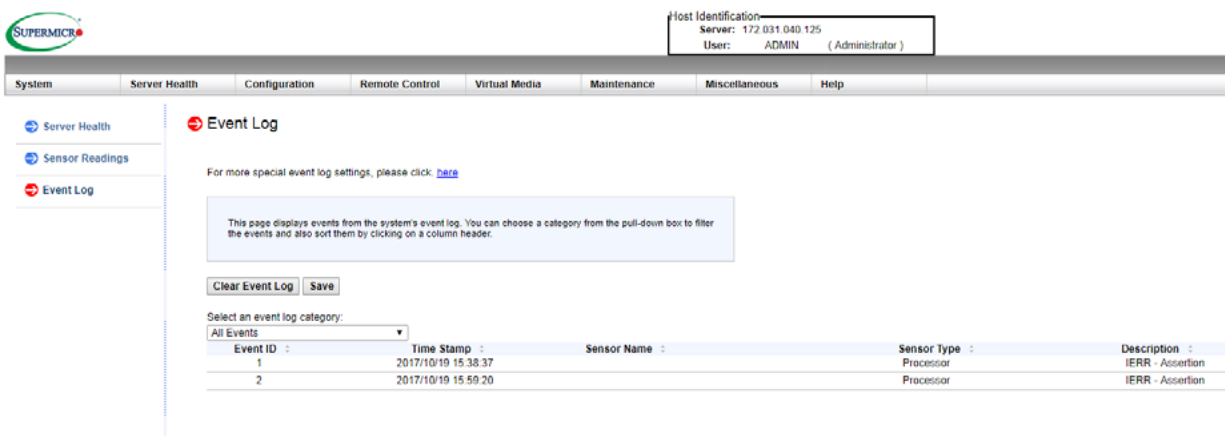

The screenshot shows the IPMI web interface. At the top right, a box displays 'Host Identification: Server: 172.031.040.125' and 'User: ADMIN (Administrator)'. Below this is a navigation menu with tabs: System, Server Health, Configuration, Remote Control, Virtual Media, Maintenance, Miscellaneous, and Help. The 'Server Health' tab is active, and the 'Event Log' sub-tab is selected. A sidebar on the left contains links for 'Server Health', 'Sensor Readings', and 'Event Log'. The main content area has a heading 'Event Log' and a note: 'For more special event log settings, please click: [here](#)'. Below this is a text box: 'This page displays events from the system's event log. You can choose a category from the pull-down box to filter the events and also sort them by clicking on a column header.' There are 'Clear Event Log' and 'Save' buttons. A dropdown menu is set to 'All Events'. Below the dropdown is a table with the following data:

| Event ID | Time Stamp | Sensor Name | Sensor Type | Description |
|----------|---------------------|-------------|-------------|------------------|
| 1 | 2017/10/19 15:38:37 | | Processor | IERR - Assertion |
| 2 | 2017/10/19 15:59:20 | | Processor | IERR - Assertion |

Figure E-1. IPMI Event Log

In the event of an IERR, the BMC executes a crash dump. You must download the crash dump and save it.

Downloading the Crash Dump File

1. In the IPMI interface, click the **Miscellaneous** tab, then the **Trouble Shooting** option.
2. Click the **Dump** button and wait five minutes for the file to be created. (No confirmation message will appear.)
3. Click the **Download** button and a Save As dialog appears.
4. Save the zipped dump file, noting the name and location.

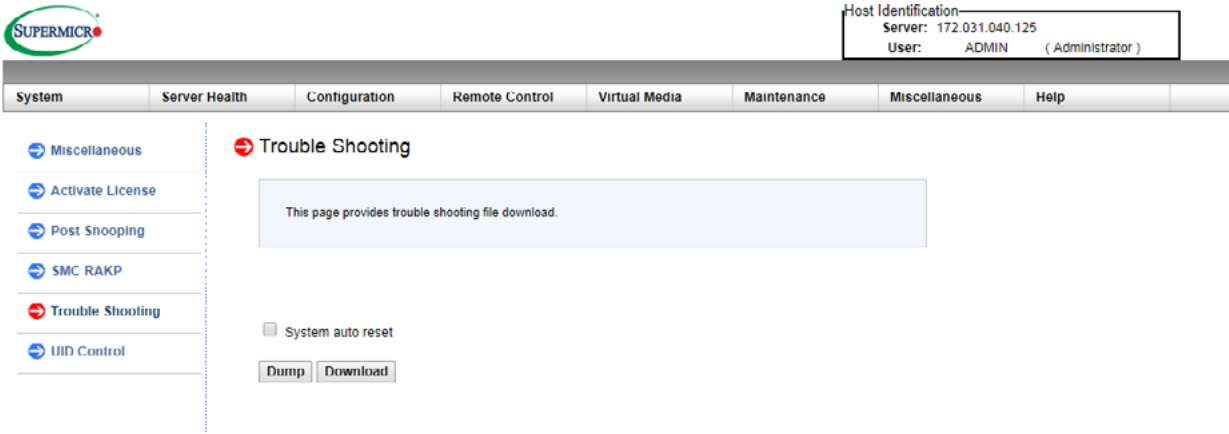

Figure E-2. IPMI Crash Dump Download

Note: The **System auto reset** check box dictates behavior after an IERR. If checked, the system will restart automatically, and the dump file will be erased. If not, the system remains in a failed state. Do not check this box until after the dump file has been sent to Support.