

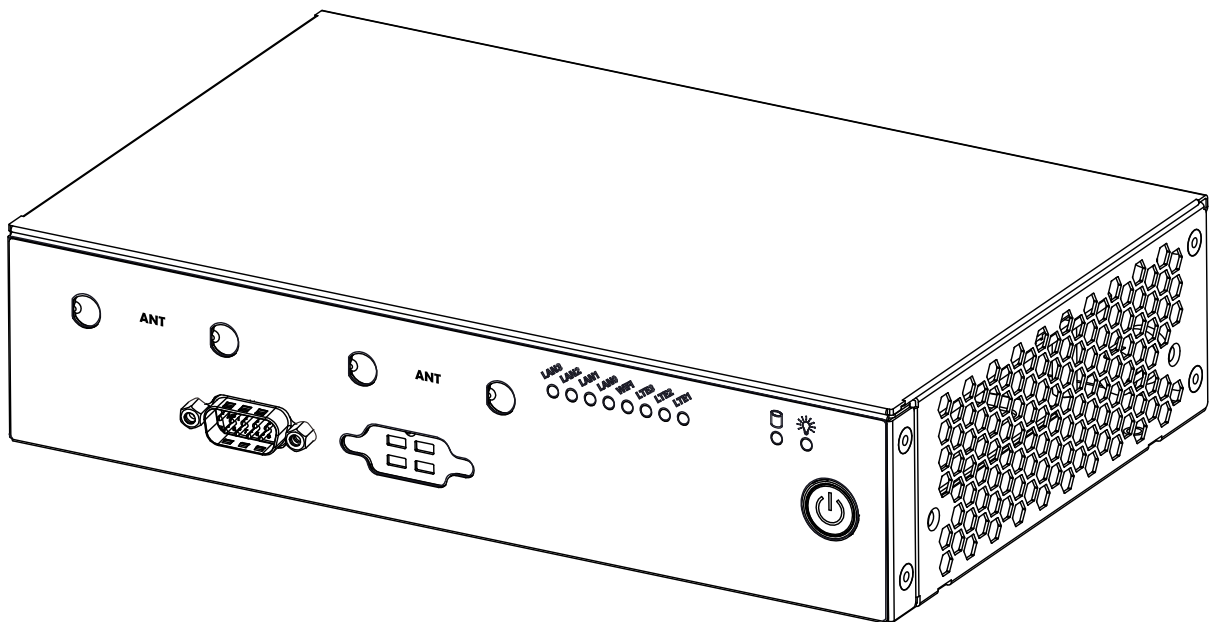

SUPERSERVER®
SYS-E102-9AP-LN4-E
SYS-E102-9AP-LN4-C



USER'S MANUAL

Revision 1.0a

The information in this User's Manual has been carefully reviewed and is believed to be accurate. The vendor assumes no responsibility for any inaccuracies that may be contained in this document, and makes no commitment to update or to keep current the information in this manual, or to notify any person or organization of the updates. Please Note: For the most up-to-date version of this manual, please see our website at www.supermicro.com.

Super Micro Computer, Inc. ("Supermicro") reserves the right to make changes to the product described in this manual at any time and without notice. This product, including software and documentation, is the property of Supermicro and/or its licensors, and is supplied only under a license. Any use or reproduction of this product is not allowed, except as expressly permitted by the terms of said license.

IN NO EVENT WILL Super Micro Computer, Inc. BE LIABLE FOR DIRECT, INDIRECT, SPECIAL, INCIDENTAL, SPECULATIVE OR CONSEQUENTIAL DAMAGES ARISING FROM THE USE OR INABILITY TO USE THIS PRODUCT OR DOCUMENTATION, EVEN IF ADVISED OF THE POSSIBILITY OF SUCH DAMAGES. IN PARTICULAR, SUPER MICRO COMPUTER, INC. SHALL NOT HAVE LIABILITY FOR ANY HARDWARE, SOFTWARE, OR DATA STORED OR USED WITH THE PRODUCT, INCLUDING THE COSTS OF REPAIRING, REPLACING, INTEGRATING, INSTALLING OR RECOVERING SUCH HARDWARE, SOFTWARE, OR DATA.

Any disputes arising between manufacturer and customer shall be governed by the laws of Santa Clara County in the State of California, USA. The State of California, County of Santa Clara shall be the exclusive venue for the resolution of any such disputes. Supermicro's total liability for all claims will not exceed the price paid for the hardware product.

FCC Statement: This equipment has been tested and found to comply with the limits for a Class A or Class B digital device pursuant to Part 15 of the FCC Rules. These limits are designed to provide reasonable protection against harmful interference when the equipment is operated in industrial environment for Class A device or in residential environment for Class B device. This equipment generates, uses, and can radiate radio frequency energy and, if not installed and used in accordance with the manufacturer's instruction manual, may cause harmful interference with radio communications. Operation of this equipment in a residential area is likely to cause harmful interference, in which case you will be required to correct the interference at your own expense.

California Best Management Practices Regulations for Perchlorate Materials: This Perchlorate warning applies only to products containing CR (Manganese Dioxide) Lithium coin cells. "Perchlorate Material-special handling may apply. See www.dtsc.ca.gov/hazardouswaste/perchlorate".



WARNING: This product can expose you to chemicals including lead, known to the State of California to cause cancer and birth defects or other reproductive harm. For more information, go to www.P65Warnings.ca.gov.

The products sold by Supermicro are not intended for and will not be used in life support systems, medical equipment, nuclear facilities or systems, aircraft, aircraft devices, aircraft/emergency communication devices or other critical systems whose failure to perform be reasonably expected to result in significant injury or loss of life or catastrophic property damage. Accordingly, Supermicro disclaims any and all liability, and should buyer use or sell such products for use in such ultra-hazardous applications, it does so entirely at its own risk. Furthermore, buyer agrees to fully indemnify, defend and hold Supermicro harmless for and against any and all claims, demands, actions, litigation, and proceedings of any kind arising out of or related to such ultra-hazardous use or sale.

Manual Revision 1.0a

Release Date: September 27, 2022

Unless you request and receive written permission from Super Micro Computer, Inc., you may not copy any part of this document. Information in this document is subject to change without notice. Other products and companies referred to herein are trademarks or registered trademarks of their respective companies or mark holders.

Copyright © 2022 by Super Micro Computer, Inc.

All rights reserved.

Printed in the United States of America

Preface

About this Manual

This manual is written for professional system integrators and PC technicians. It provides information for the installation and use of the server. Installation and maintenance should be performed by experienced technicians only.

Please refer to the SYS-E102-9AP-LN4-E/-C server specifications page on our website for updates on supported memory, processors and operating systems (<http://www.supermicro.com>).

Notes

For your system to work properly, please follow the links below to download all necessary drivers/utilities and the user's manual for your server.

- Supermicro product manuals: <http://www.supermicro.com/support/manuals/>
- Product drivers and utilities: <https://www.supermicro.com/wdl>
- Product safety info: http://www.supermicro.com/about/policies/safety_information.cfm

If you have any questions, please contact our support team at:
support@supermicro.com

This manual may be periodically updated without notice. Please check the Supermicro website for possible updates to the manual revision level.

Secure Data Deletion

A secure data deletion tool designed to fully erase all data from storage devices can be found on our website: https://www.supermicro.com/about/policies/disclaimer.cfm?url=/wdl/utility/Log9_Secure_Data_Deletion_Utility/

Warnings

Special attention should be given to the following symbols used in this manual.



Warning! Indicates important information given to prevent equipment/property damage or personal injury.



Warning! Indicates high voltage may be encountered when performing a procedure.

Contents

Contacting Supermicro.....	7
Chapter 1 Introduction	
1.1 Overview.....	8
1.2 System Features	9
Front View	9
Control Panel.....	10
Rear View.....	11
Side View	12
1.3 System Architecture	13
System Block Diagram.....	13
1.4 Motherboard Layout	14
Quick Reference Table.....	15
Chapter 2 Server Installation	
2.1 Overview.....	17
2.2 Unpacking the System	17
2.3 Preparing for Setup.....	17
Choosing a Setup Location.....	17
Rack Precautions	18
Server Precautions.....	18
Rack Mounting Considerations	18
Ambient Operating Temperature.....	18
Airflow	19
Mechanical Loading.....	19
Circuit Overloading	19
Reliable Ground.....	19
2.4 Installing Mounting Brackets (Optional)	20
Chapter 3 Maintenance and Component Installation	
3.1 Removing Power	21
3.2 Accessing the System.....	22
Removing the Top Cover.....	22
3.3 Static-Sensitive Devices.....	23
Precautions	23
Unpacking	23

3.4	Motherboard Installation.....	24
	Tools Needed	24
	Location of Mounting Holes	24
	Installing the Motherboard.....	25
3.5	Memory Support and Installation	26
	Memory Support.....	26
	SO-DIMM Installation	27
	SO-DIMM Removal	27
3.6	M.2 Installation for JMD2 and JMD4.....	28
3.7	Motherboard Battery.....	29
	Battery Removal.....	29
	Proper Battery Disposal	29
	Battery Installation.....	29
3.8	Chassis Components	30
	Storage Drives	30
	System Fans	31
Chapter 4 Motherboard Connections		
4.1	Power Connections	32
4.2	Headers and Connectors	33
	Control Panel.....	39
4.3	Input/Output Ports	41
4.4	Jumpers.....	43
4.5	LED Indicators.....	44
Chapter 5 Software		
5.1	Microsoft Windows OS Installation.....	45
5.2	Driver Installation.....	47
5.3	SuperDoctor® 5	48
5.4	IPMI	49
	BMC ADMIN User Password	49
Chapter 6 Troubleshooting and Support		
6.1	Information Resources	50
	Website	50
	Direct Links for the SYS-E102-9AP-LN4-E/-C System	50
	Direct Links for General Support and Information	50

6.2 Intelligent Platform Management Interface (IPMI)	51
6.3 Troubleshooting Procedures	52
No Power	52
No Video	53
System Boot Failure	53
Memory Errors	53
Losing the System's Setup Configuration	53
When the System Becomes Unstable	53
6.4 BIOS Error Beep (POST) Codes	55
Additional BIOS POST Codes	55
6.5 Crash Dump Using IPMI	56
6.6 CMOS Clear	57
6.7 Where to Get Replacement Components	58
6.8 Reporting an Issue	58
Technical Support Procedures	58
Returning Merchandise for Service	58
Vendor Support Filing System	59
6.9 Feedback	59
6.10 Contacting Supermicro	60
<i>Appendix A Standardized Warning Statements for AC Systems</i>	
<i>Appendix B System Specifications</i>	

Contacting Supermicro

Headquarters

Address: Super Micro Computer, Inc.
980 Rock Ave.
San Jose, CA 95131 U.S.A.

Tel: +1 (408) 503-8000

Fax: +1 (408) 503-8008

Email: marketing@supermicro.com (General Information)
Sales-USA@supermicro.com (Sales Inquiries)
Government_Sales-USA@supermicro.com (Gov. Sales Inquiries)
support@supermicro.com (Technical Support)
RMA@supermicro.com (RMA Support)
Webmaster@supermicro.com (Webmaster)

Website: www.supermicro.com

Europe

Address: Super Micro Computer B.V.
Het Sterrenbeeld 28, 5215 ML
's-Hertogenbosch, The Netherlands

Tel: +31 (0) 73-6400390

Fax: +31 (0) 73-6416525

Email: Sales_Europe@supermicro.com (Sales Inquiries)
Support_Europe@supermicro.com (Technical Support)
RMA_Europe@supermicro.com (RMA Support)

Website: www.supermicro.nl

Asia-Pacific

Address: Super Micro Computer, Inc.
3F, No. 150, Jian 1st Rd.
Zhonghe Dist., New Taipei City 235
Taiwan (R.O.C)

Tel: +886-(2) 8226-3990

Fax: +886-(2) 8226-3992

Email: Sales-Asia@supermicro.com.tw (Sales Inquiries)
Support@supermicro.com.tw (Technical Support)
RMA@supermicro.com.tw (RMA Support)

Website: www.supermicro.com.tw

Chapter 1

Introduction

1.1 Overview

This chapter provides a brief outline of the functions and features of the SuperServer SYS-E102-9AP-LN4-E/-C. It is based on the A2SAN-LN4-E/-C motherboard and the CSE-E102TF chassis. The SYS-E102-9AP-LN4-E/-C is a high-performance 3.5" SBC server ideal for network security appliances, SD-WAN, IoT gateways, and embedded networking applications.

The following provides an overview of the specifications and capabilities.

System Overview	
Motherboard	A2SAN-LN4-E/-C
Chassis	Compact Embedded 3.5" SBC Box, CSE-E102TF
Processor Support	A2SAN-LN4-E: Intel® Atom™ x5-E3940 Processor, Quad Core, 2M Cache, 1.6GHz-1.8GHz, TDP 9.5W A2SAN-LN4-C: Intel® Celeron® J3455 Processor, Quad Core, 2M Cache, 1.5GHz-2.3GHz, TDP 10W
Memory	Integrated memory controller supports up to 8GB DDR3L 1866MHz Non-ECC SO-DIMM
Drive Support	One SATA 3.0 for 2.5" 7mm SATA HDD/SSD
Expansion Slots	One Full size Mini-PCIe (1 USB 2.0, 1 PCIe Gen2) Three M.2 B-Key (USB) 2242/3042 with Nano SIM Slots One M.2 E-Key 2230
I/O Ports	LAN: Four Gigabit Ethernet ports USB: Two USB3.0 ports (rear) Display: One HDMI One COM port
System Cooling	One 4-cm PWM system fan
Power	One lockable 60 watt power adapter for 12VDC
Form Factor	3.5" SBC 7.48 x 1.72 x 4.72 in. (190 x 44 x 120 mm) (WxDxH)

Note: A Quick Reference guide can be found on the product page of the Supermicro website.

Note:The following safety models associated with the SYS-E102-9AP-LN4-E/-C have been certified as compliant with UL or CSA: E102-EBD, E102-60, E102-A6A2.

Note: When shipping from Taiwan, end users cannot insert a SIM card to enable the wireless communication function of the SYS-E102-9AP-LN4-E/-C. The SYS-E102-9AP-LN4-E/-C will not accept any SIM card from any telecom operator nor provide any built-in RF Module.

1.2 System Features

The following views of the system display the main features. Refer to [Appendix B](#) for additional specifications.

Front View

The illustration below shows the features included on the front of the chassis.

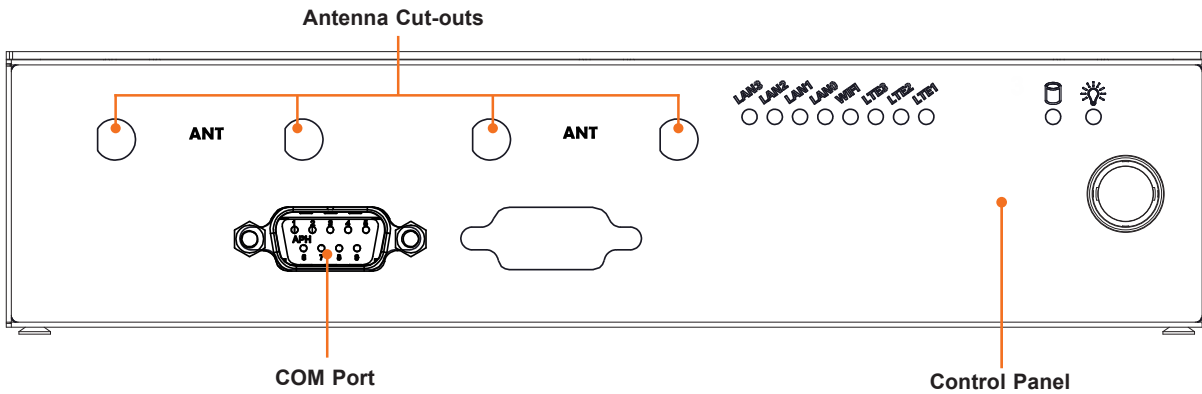

Figure 1-1. Front View

Front View Features	
Feature	Description
COM Port	One serial port
Antenna Cut-outs	Four cut-outs for mounting antennas
Control Panel	Power button and status indicators; see the next page.

Control Panel

Power switches and status LEDs are located on the control panel on the front of the chassis.

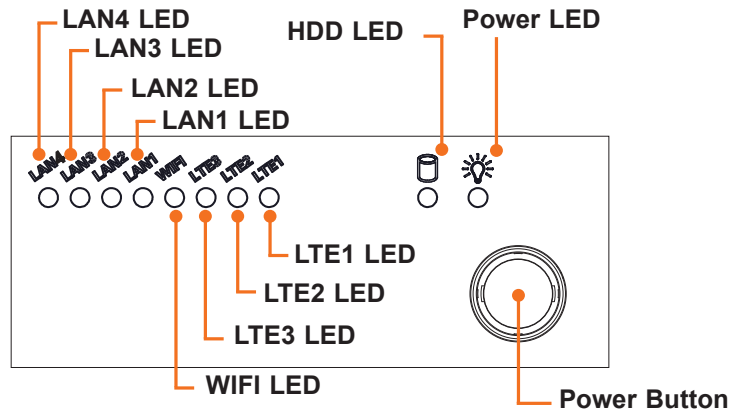

Figure 1-2. Control Panel

Control Panel Features	
Feature	Description
Power Button	Applies or removes power from the power supply to the server; standby power is maintained
Power LED	Indicates power is being supplied to the system power supply; illuminated when the system is operating normally
HDD LED	Indicates hard drive activity when flashing
LTE1 LED	WAN connection
LTE2 LED	WAN connection
LTE3 LED	WAN connection
WIFI LED	Wireless Network connection
LAN1 LED	Indicates network activity on LAN port 1 when flashing
LAN2 LED	Indicates network activity on LAN port 2 when flashing
LAN3 LED	Indicates network activity on LAN port 3 when flashing
LAN4 LED	Indicates network activity on LAN port 4 when flashing

Status LED	
Status	Description
Continuous on and red	An overheat condition has occurred. (This may be caused by cable congestion.)
Blinking red (1Hz)	Fan failure, check for an inoperative fan.
Blinking red (0.25Hz)	Power failure, check for a non-operational power supply.
Solid blue	UID has been activated locally to locate the server in a rack environment.
Blinking blue	UID has been activated using IPMI to locate the server in a rack environment.

Rear View

The illustration below shows the features included on the rear of the chassis. The power supply module displays status lights.

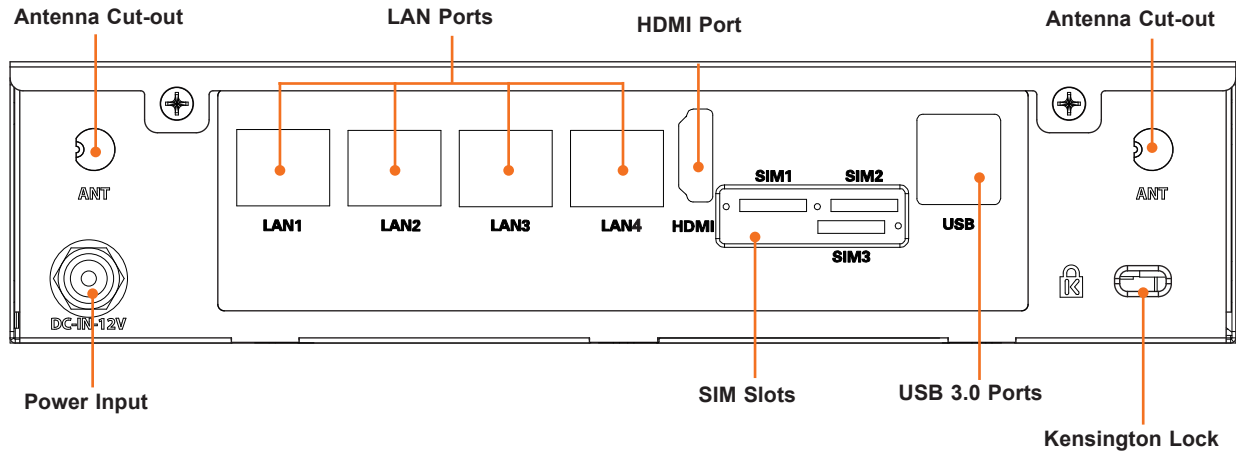

Figure 1-3. System Rear View

System Features: Rear	
Feature	Description
Power Input	Use this port for the 60W DC power input.
Antenna Cut-outs	Two cut-outs for mounting antennas.
LAN Ports	Four 1GbE network ports.
HDMI	One HDMI port.
SIM Slots	Three SIM slots.
USB	Two USB 3.0 ports.
Kensington® Lock	One slot for Kensington security cable/lock.

Side View

The illustration below shows the features included on the side of the chassis.

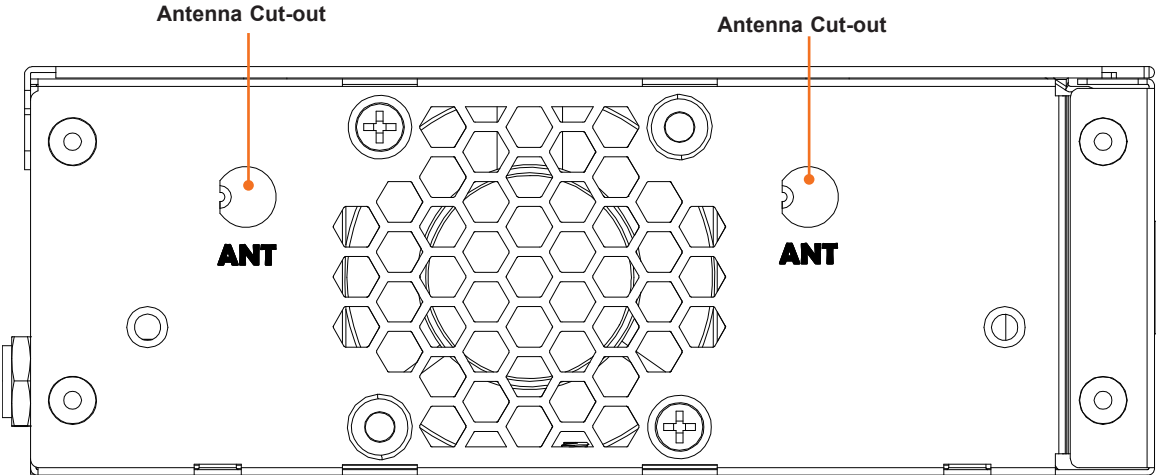

Figure 1-4. System Side View

System Features: Side	
Feature	Description
Antenna Cut-outs	Two cut-outs for mounting antennas.

1.3 System Architecture

System Block Diagram

The block diagram below shows the connections and relationships between the subsystems and major components of the overall system.

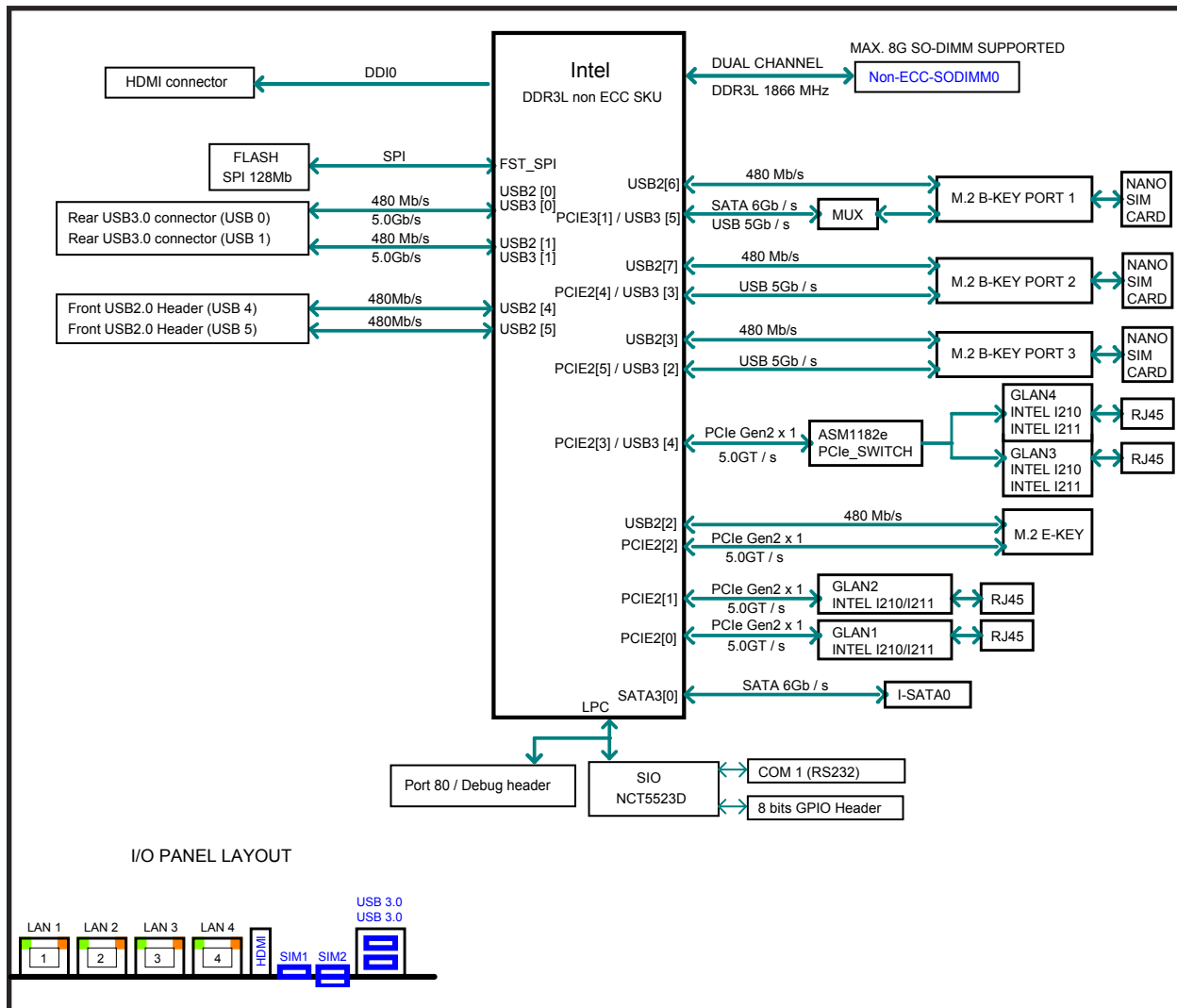

Figure 1-5. System Block Diagram

Note: This is a general block diagram and may not exactly represent the features on your motherboard.

1.4 Motherboard Layout

Below is a layout of the A2SAN-LN4-E/C motherboard with jumper, connector and LED locations shown. See the table on the following page for descriptions. For detailed descriptions, pinout information and jumper settings, refer to [Chapter 4](#) or the [Motherboard Manual](#).

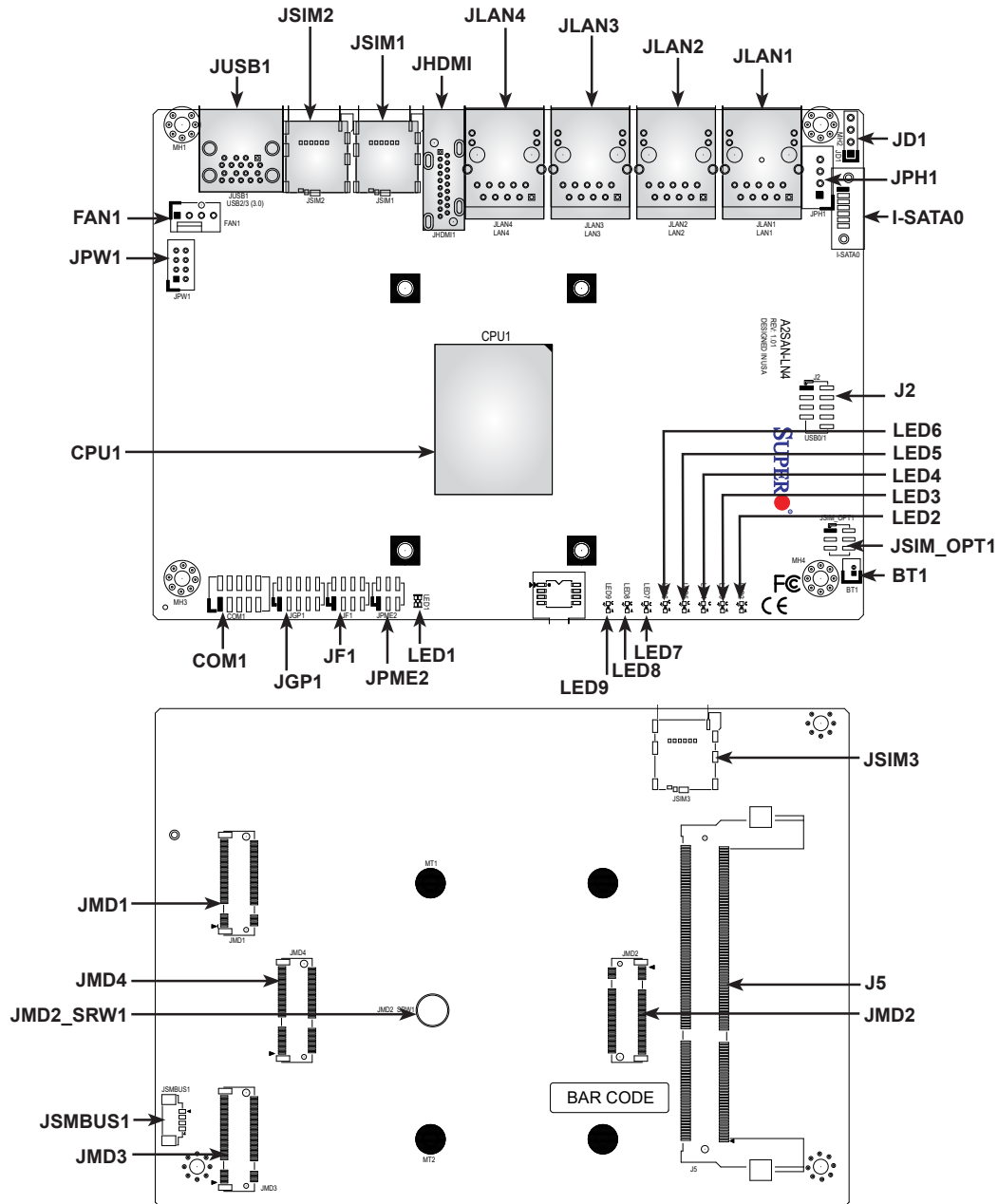

Figure 1-6. Motherboard Layout (Top Side and Bottom Side)

Notes:

- "■" indicates the location of Pin 1.
- To avoid possible explosion, please use the correct type battery.

Quick Reference Table

Jumper	Description	Default Setting
JPME2	Manufacturing Mode	Pins 3-5: Normal
JPME2	Power Force On	Pins 2-4: Power Force On
JSIM_OPT1	SIM Card Detection	Pins 1-2 (JSIM1) Pins 3-4 (JSIM2) Pins 5-6 (JSIM3) Closed: Low Active

LED	Description	Status
LED1	Power Good LED	Solid Green: All Power Good Solid Red: Power Fail
LED2	M.2 Active LED (for JMD1)	Activity Behavior: Depends on Module
LED3	M.2 Active LED (for JMD2)	Activity Behavior: Depends on Module
LED4	M.2 Active LED (for JMD3)	Activity Behavior: Depends on Module
LED5	M.2 Active LED (for JMD4)	Activity Behavior: Depends on Module
LED6	GbE LAN Active LED (for JLAN1)	Blinking Amber: LAN Active
LED7	GbE LAN Active LED (for JLAN2)	Blinking Amber: LAN Active
LED8	GbE LAN Active LED (for JLAN3)	Blinking Amber: LAN Active
LED9	GbE LAN Active LED (for JLAN4)	Blinking Amber: LAN Active

Connector	Description
BT1	Battery Connector (To clear the CMOS, remove the battery and power input, short pins 1-2 for more than 10 seconds and install the battery.)
COM1	Serial COM Port (supports RS-232 x 1)
FAN1	System Fan Header
I-SATA0	Intel PCH SATA 3.0 Port
J2	USB 2.0 Header
J5	SO-DIMM Slot (bottom side layout)
JD1	Speaker Header (Pins 1-4)
JF1	Front Control Panel Header
JGP1	8-bit General Purpose I/O Header
JHDMI1	Back Panel HDMI Port
JLAN1 - JLAN4	LAN1 - LAN4 (RJ45) Ports
JMD1	M.2 B-Key 2242/3042 Slot (supports USB2.0/3.0 with Nano SIM for LTE/3G) (supports SATA upon request)
JMD2, JMD3	M.2 B-Key 2242/3042 Slots (supports USB2.0/3.0 with Nano SIM for LTE/3G)
JMD4	M.2 E-Key 2230 Slot (supports PCIe x1/USB2.0 with WiFi + BT)
JMD2_SRW1	M.2 Mounting Screw for JMD2 (bottom side layout)

Note: Table continues on the next page.

Connector	Description
JPH1	SATA Power Connector
JPW1	8-pin 12V DC Power Connector
JSIM1	Nano SIM Card Slot for JDM1
JSIM2	Nano SIM Card Slot for JDM2
JSIM3	Nano SIM Card Slot for JDM3 (bottom side layout)
JSMBUS1	System Management Bus Header (bottom side layout)
JUSB1	Back Panel Universal Serial Bus (USB) 3.0 Ports (USB 3.0 x 2)
MH1 - MH4	Mounting Holes
MT1	M.2 Mounting Screw for JDM1 (bottom side layout)
MT2	M.2 Mounting Screw for JDM3 (bottom side layout)

Chapter 2

Server Installation

2.1 Overview

This chapter provides advice and instructions for mounting your system in a server rack. If your system is not already fully integrated with processors, system memory etc., refer to [Chapter 3](#) for details on installing those specific components.

Caution: Electrostatic Discharge (ESD) can damage electronic components. To prevent such damage to PCBs (printed circuit boards), it is important to use a grounded wrist strap, handle all PCBs by their edges and keep them in anti-static bags when not in use.

2.2 Unpacking the System

Inspect the box in which the SYS-E102-9AP-LN4-E/-C was shipped, and note if it was damaged in any way. If any equipment appears damaged, file a damage claim with the carrier who delivered it.

Decide on a suitable location for the rack unit that will hold the server. It should be situated in a clean, dust-free area that is well ventilated. Avoid areas where heat, electrical noise and electromagnetic fields are generated. It will also require a grounded AC power outlet nearby. Be sure to read the precautions and considerations noted in [Appendix A](#).

2.3 Preparing for Setup

The box in which the system was shipped should include the rackmount hardware needed to install it into the rack. Please read this section in its entirety before you begin the installation.

Choosing a Setup Location

- The system should be situated in a clean, dust-free area that is well ventilated. Avoid areas where heat, electrical noise and electromagnetic fields are generated.
- Leave enough clearance in front of the rack so that you can open the front door completely (~25 inches) and approximately 30 inches of clearance in the back of the rack to allow sufficient space for airflow and access when servicing.
- This product should be installed only in a Restricted Access Location (dedicated equipment rooms, service closets, etc.).

- This product is not suitable for use with visual display workplace devices according to §2 of the German Ordinance for Work with Visual Display Units.

Rack Precautions

- Ensure that the leveling jacks on the bottom of the rack are extended to the floor so that the full weight of the rack rests on them.
- In single rack installations, stabilizers should be attached to the rack. In multiple rack installations, the racks should be coupled together.
- Always make sure the rack is stable before extending a server or other component from the rack.
- You should extend only one server or component at a time - extending two or more simultaneously may cause the rack to become unstable.

Server Precautions

- Review the electrical and general safety precautions in [Appendix A](#).
- Determine the placement of each component in the rack before you install the rails.
- Install the heaviest server components at the bottom of the rack first and then work your way up.
- Use a regulating uninterruptible power supply (UPS) to protect the server from power surges and voltage spikes and to keep your system operating in case of a power failure.
- Allow any drives and power supply modules to cool before touching them.
- When not servicing, always keep the front door of the rack and all covers/panels on the servers closed to maintain proper cooling.

Rack Mounting Considerations

Ambient Operating Temperature

If installed in a closed or multi-unit rack assembly, the ambient operating temperature of the rack environment may be greater than the room's ambient temperature. Therefore, consideration should be given to installing the equipment in an environment compatible with the manufacturer's maximum rated ambient temperature (TMRA).

Airflow

Equipment should be mounted into a rack so that the amount of airflow required for safe operation is not compromised.

Mechanical Loading

Equipment should be mounted into a rack so that a hazardous condition does not arise due to uneven mechanical loading.

Circuit Overloading

Consideration should be given to the connection of the equipment to the power supply circuitry and the effect that any possible overloading of circuits might have on overcurrent protection and power supply wiring. Appropriate consideration of equipment nameplate ratings should be used when addressing this concern.

Reliable Ground

A reliable ground must be maintained at all times. To ensure this, the rack itself should be grounded. Particular attention should be given to power supply connections other than the direct connections to the branch circuit (i.e. the use of power strips, etc.).



To prevent bodily injury when mounting or servicing this unit in a rack, you must take special precautions to ensure that the system remains stable. The following guidelines are provided to ensure your safety:

- This unit should be mounted at the bottom of the rack if it is the only unit in the rack.
- When mounting this unit in a partially filled rack, load the rack from the bottom to the top with the heaviest component at the bottom of the rack.
- If the rack is provided with stabilizing devices, install the stabilizers before mounting or servicing the unit in the rack.



Slide rail mounted equipment is not to be used as a shelf or a work space.



Warning: do not pick up the server with the front handles. They are designed to pull the system from a rack only.

2.4 Installing Mounting Brackets (Optional)

The chassis includes mounting brackets that fit the VESA standard or can be wall-mounted. For wall mounting, the brackets extend out from the chassis as shown below.

1. Install the brackets using the four provided screws as shown below.

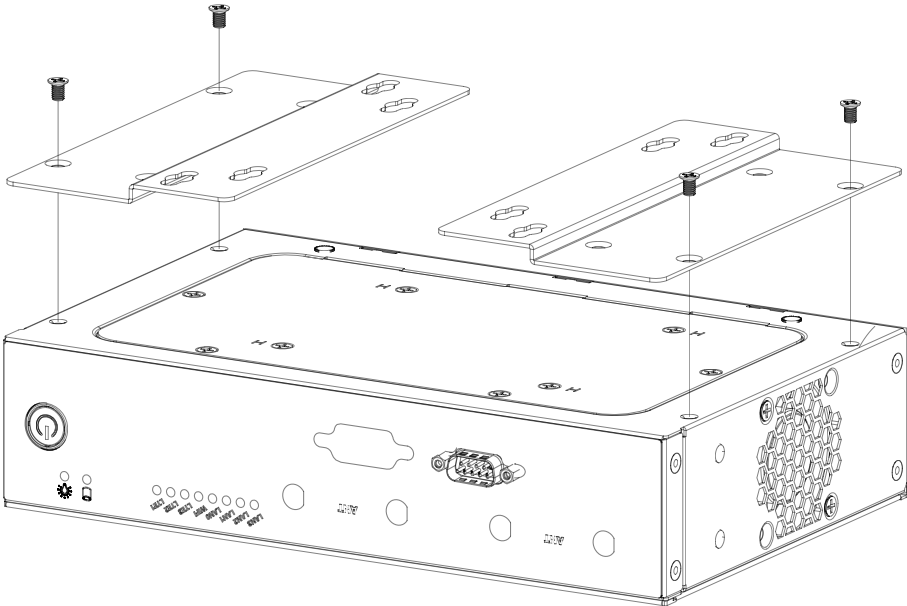

Figure 2-1. Installing VESA Mount Brackets

2. Secure the brackets to the surface where you want the server to be mounted.
 - For VESA mount, slide onto existing posts.
 - For wall mount, affix screws through the bracket holes.

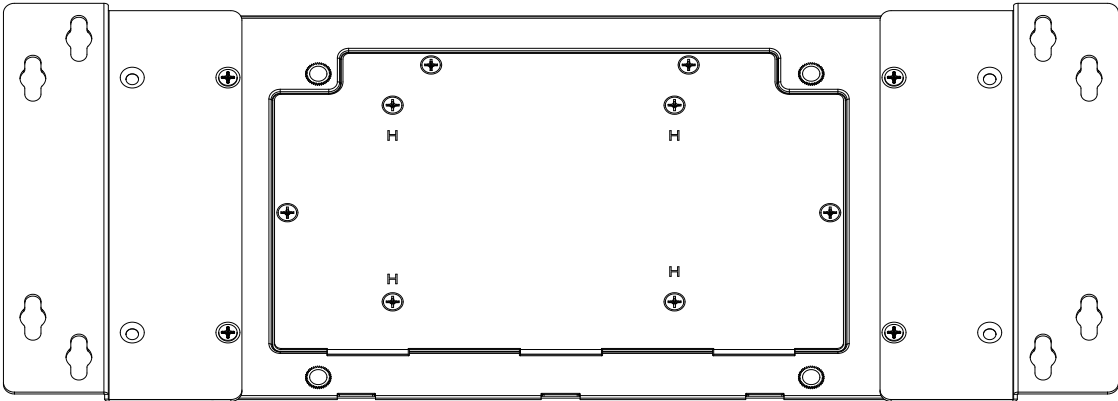

Figure 2-2. Installed Wall Mount Brackets (Viewed from under the Chassis)

Chapter 3

Maintenance and Component Installation

This chapter provides instructions on installing and replacing main system components. To prevent compatibility issues, only use components that match the specifications and/or part numbers given.

Installation or replacement of most components require that power first be removed from the system. Please follow the procedures given in each section.

3.1 Removing Power

Use the following procedure to ensure that power has been removed from the system. This step is necessary when removing or installing non hot-swap components or when replacing a non-redundant power supply.

1. Use the operating system to power down the system.
2. After the system has completely shut-down, disconnect the AC power cord(s) from the power strip or outlet. (If your system has more than one power supply, remove the AC power cords from all power supply modules.)
3. Disconnect the power cord(s) from the power supply module(s).

3.2 Accessing the System

The CSE-E102TF chassis features a removable top cover, which allows easy access to the inside of the chassis.

Removing the Top Cover

1. On the chassis rear, remove the two screws.

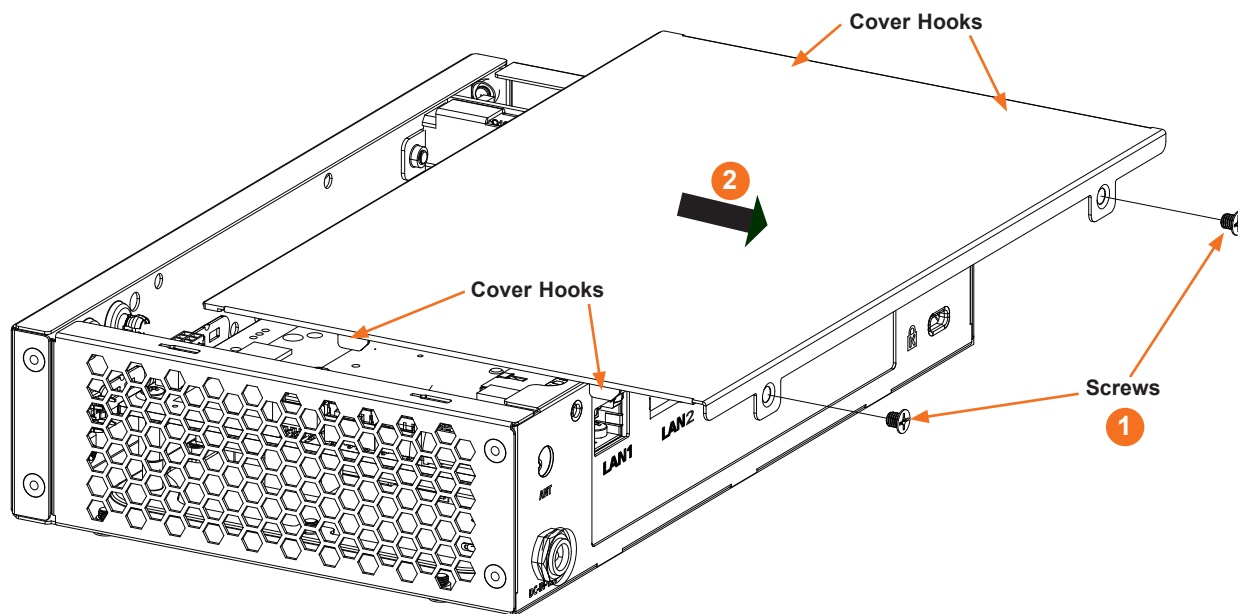

Figure 3-1. Removing the Chassis Cover

2. Slide the cover to the rear as illustrated above to release the cover hooks from the chassis, and lift the cover off.

Caution: Except for short periods of time, do not operate the server without the cover in place. The chassis cover must be in place to allow for proper airflow and to prevent overheating.

3.3 Static-Sensitive Devices

Electrostatic Discharge (ESD) can damage electronic components. To avoid damaging your motherboard, it is important to handle it very carefully. The following measures are generally sufficient to protect the system PCBs from ESD.

Precautions

- Use a grounded wrist strap designed to prevent static discharge.
- Touch a grounded metal object before removing any PCB (printed circuit board) from its antistatic bag.
- Handle PCBs by their edges only; do not touch its components, peripheral chips, memory modules or gold contacts.
- When handling chips or modules, avoid touching their pins.
- Put the PCBs back into their antistatic bags when not in use.
- Use only the correct type of onboard CMOS battery. Do not install the onboard battery upside down to avoid possible explosion.

Unpacking

The motherboard is shipped in antistatic packaging to avoid static damage. When unpacking the motherboard, make sure that the person handling it is static protected.

3.4 Motherboard Installation

All motherboards have standard mounting holes to fit different types of chassis. Make sure that the locations of all the mounting holes for both the motherboard and the chassis match. Although a chassis may have both plastic and metal mounting fasteners, metal ones are highly recommended because they ground the motherboard to the chassis. Make sure that the metal standoffs click in or are screwed in tightly.

Tools Needed

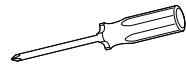

**Phillips
Screwdriver
(1)**



**Phillips Screws
(4)**



**Standoffs (4)
Only if Needed**

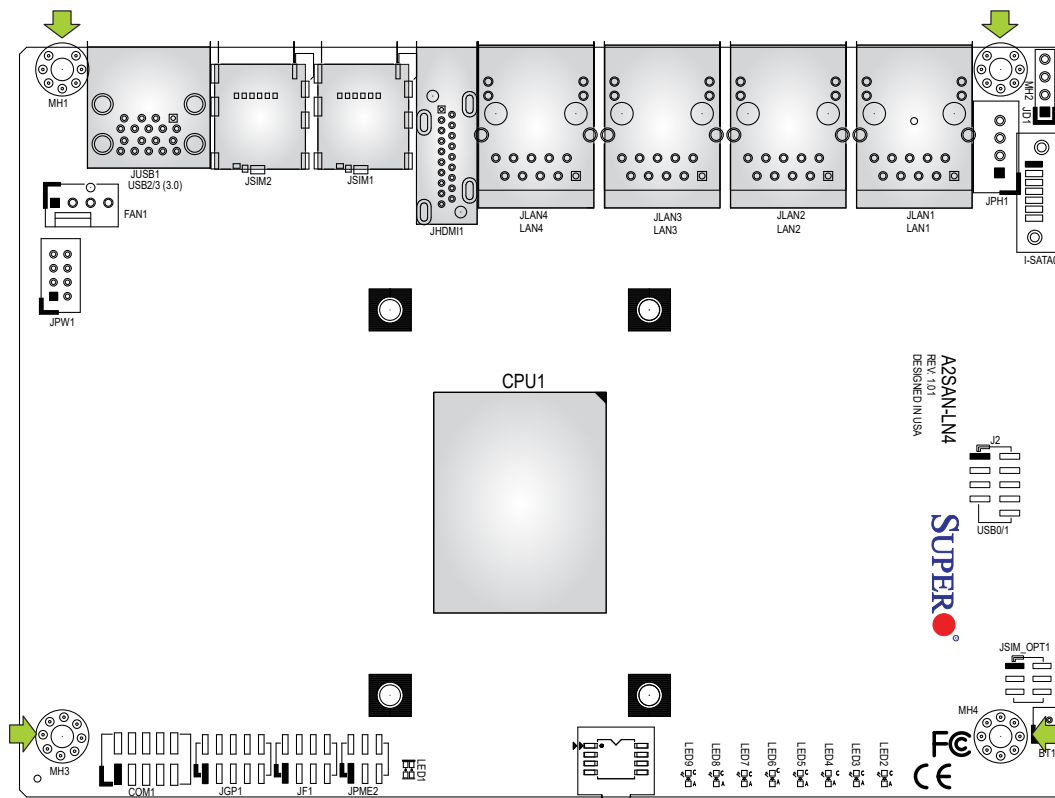

Location of Mounting Holes

Note 1: To avoid damaging the motherboard and its components, please do not use a force greater than 8 lbf-in on each mounting screw during motherboard installation.

Note 2: Some components are very close to the mounting holes. Please take precautionary measures to avoid damaging these components when installing the motherboard to the chassis.

Installing the Motherboard

1. Locate the mounting holes on the motherboard. See the previous page for the location.

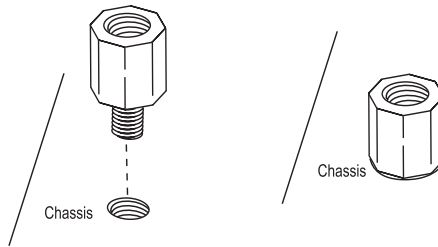

2. Locate the matching mounting holes on the chassis. Align the mounting holes on the motherboard against the mounting holes on the chassis.

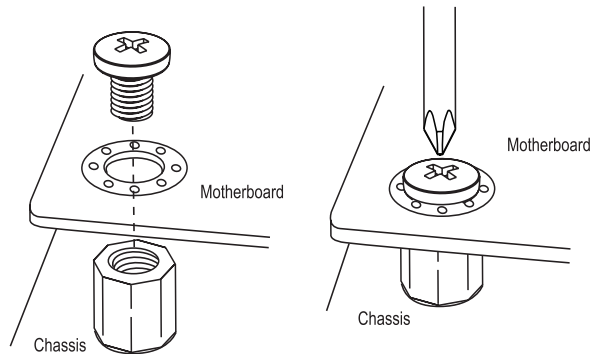

3. Install standoffs in the chassis as needed.
4. Install the motherboard into the chassis carefully to avoid damaging other motherboard components.
5. Using the Phillips screwdriver, insert a pan head #6 screw into a mounting hole on the motherboard and its matching mounting hole on the chassis.
6. Repeat Step 5 to insert #6 screws into all mounting holes.
7. Make sure that the motherboard is securely placed in the chassis.

Note: Images displayed are for illustration only. Your chassis or components might look different from those shown in this manual.

3.5 Memory Support and Installation

Note: Check the Supermicro website for recommended memory modules.

Important: Exercise extreme care when installing or removing DIMM modules to prevent any possible damage.

Memory Support

The A2SAN-LN4-E/-C supports up to 8GB DDR3L 1866MHz Non-ECC SO-DIMM in one memory slot on the bottom side of the motherboard.

Bottom Layout

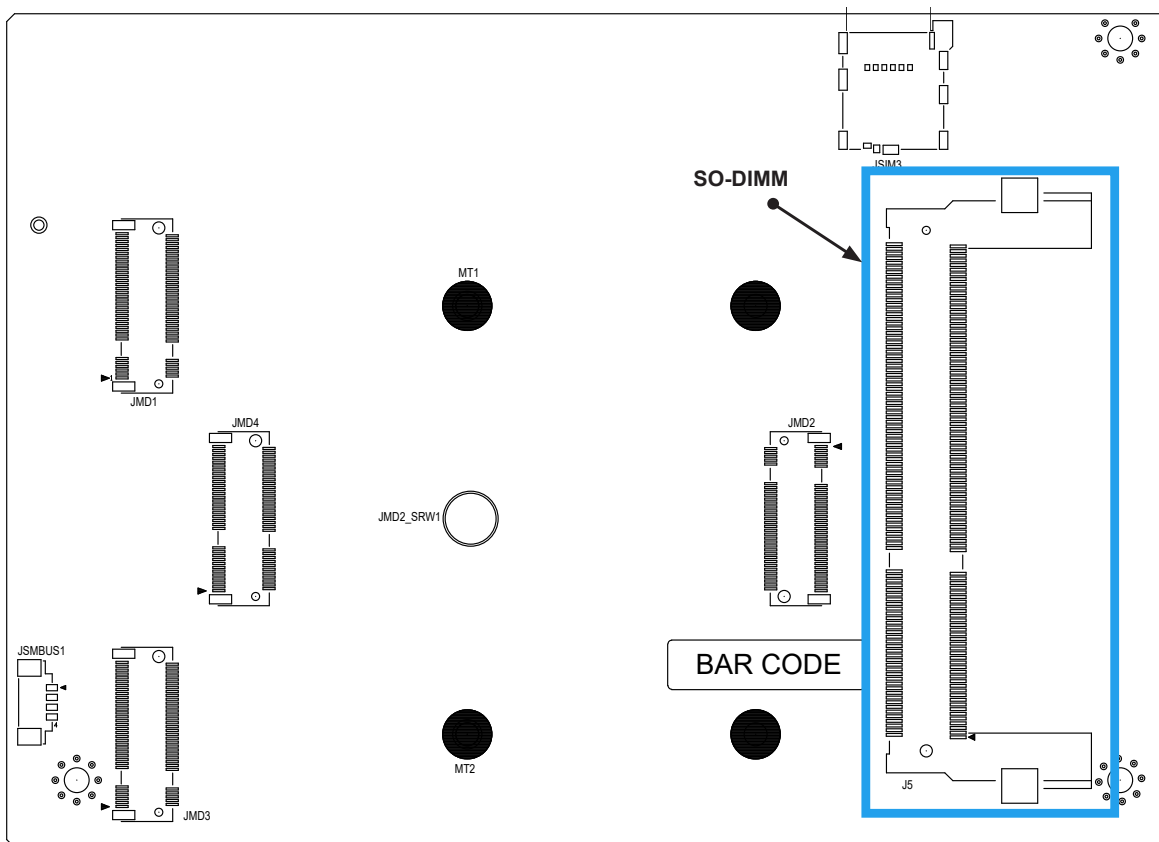

SO-DIMM Installation

1. Insert the SO-DIMM module vertically at about a 45 degree angle. Press down until the module locks into place. The side clips will automatically secure the SO-DIMM module, locking it into place.

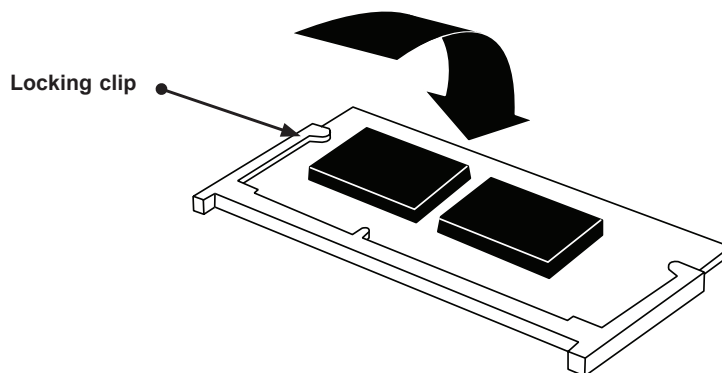
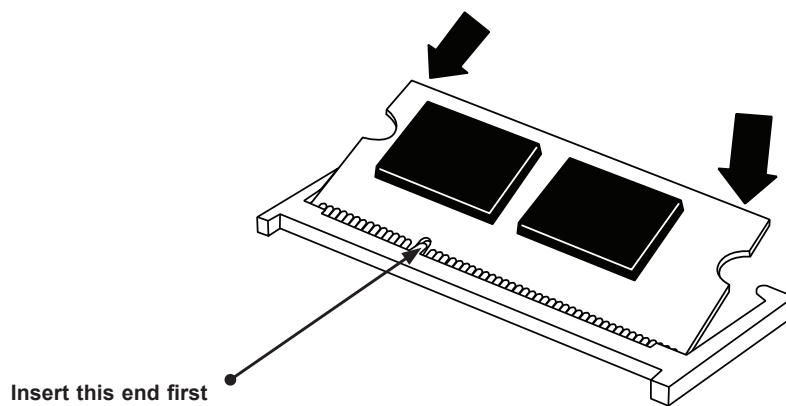

SO-DIMM Removal

1. Push the side clips at the end of the slot to release the SO-DIMM module. Pull the SO-DIMM module up to remove it from the slot.

3.6 M.2 Installation for JMD2 and JMD4

1. Unfasten the screw from JMD2-SRW1.
2. Insert the M.2 modules into JMD2 and JMD4 and press both modules down at the same time.
3. Secure the modules by fastening the screw.

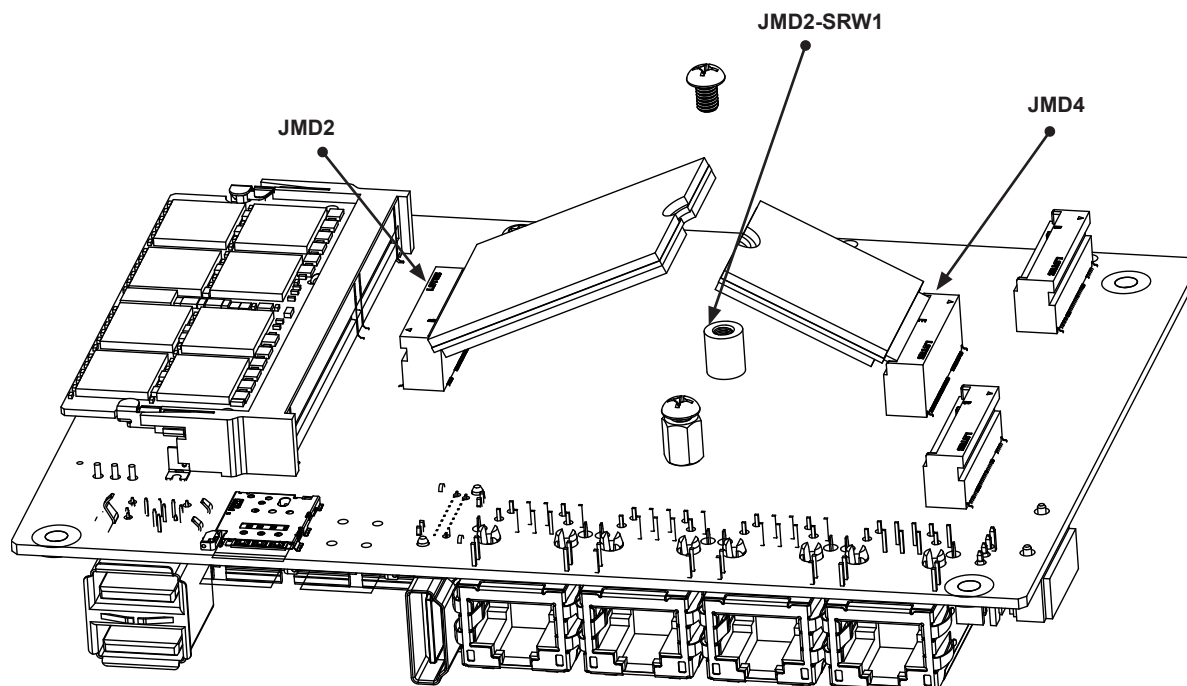

3.7 Motherboard Battery

Battery Removal

To remove the battery, follow the steps below:

1. Power off your system and unplug the power cord.
2. Remove the battery cable at the BT1 connector on the board.
3. Remove the battery.

Proper Battery Disposal

Warning: Please handle used batteries carefully. Do not damage the battery in any way; a damaged battery may release hazardous materials into the environment. Do not discard a used battery in the garbage or a public landfill. Please comply with the regulations set up by your local hazardous waste management agency to dispose of your used battery properly.

Battery Installation

1. Unplug the power cord.
2. Connect the battery cable into the battery connector (BT1) and push it down until you hear a click to ensure that the cable is securely locked.
3. Use the foam tape on the back side of the battery to secure the battery to a flat surface on the bottom of the motherboard or a proper location in the system. **DO NOT** place the battery on the heatsink.

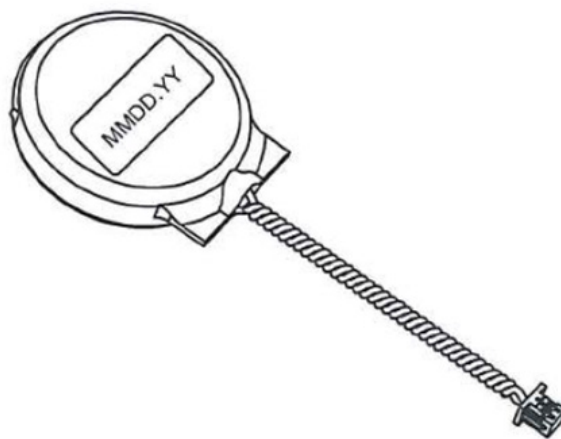

3.8 Chassis Components

Storage Drives

The CSE-E102TF chassis can accommodate a single fixed 2.5" storage drive of 7-mm thickness. It is installed to the inside of the bottom cover of the chassis. Use an enterprise quality drive.

The system also supports an M.2 SSD storage card. See the description in Section 3.5.

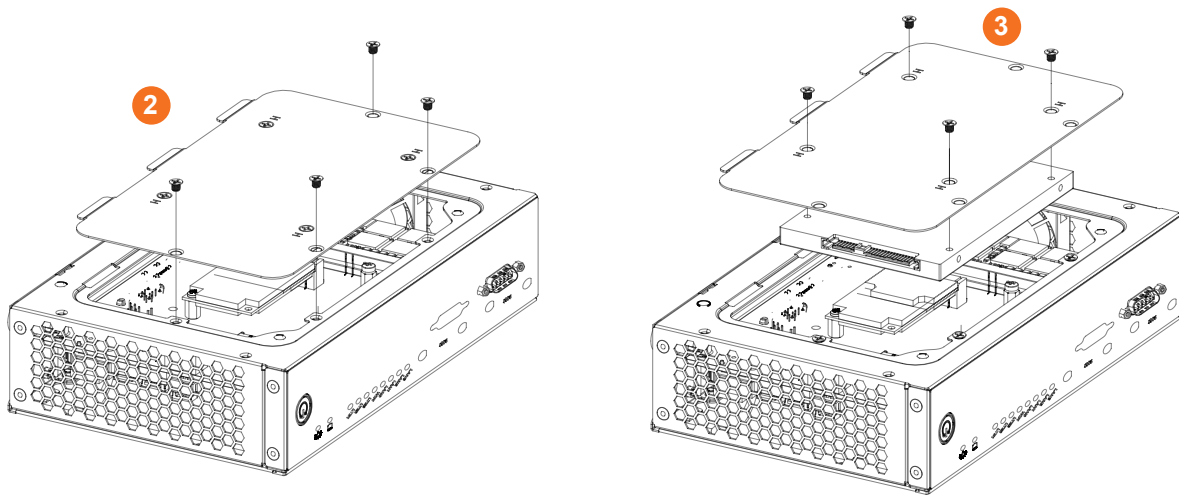

Figure 3-2. Installing the Hard Drive

Installing the Hard Drive

The motherboard should be installed before installing the hard drive.

1. Make sure there is no power to the system as described in Section 3.1.
2. Remove the four screws securing the bottom cover tray to the chassis and set them aside for later use. Lift the cover out. On the inside of this bottom cover is where the hard drive is mounted.
3. Place the hard drive on to the inside of the bottom cover and secure it to the tray with the four screws provided with the hard drive, as shown.
4. Attach the cable SATA connector and to the motherboard connector. This cable carries both the SATA signal and the SATA power.
5. Return the hard drive bottom cover assembly into the chassis, aligning the screw holes of the bottom tray with the holes in the chassis. Secure the tray to the chassis support bracket with the screws previously set aside.
6. Power up the system.

System Fans

The chassis includes one 4-cm fan.

Replacing the System Fan

1. Power down the system as described in Section 3.1 and remove the chassis cover.
2. Remove the failed fan power cable from motherboard.
3. Remove the motherboard from the chassis.
4. Remove the screws securing the fan to the chassis wall and set these aside.
5. Lift the fan out of the chassis.
6. Align the replacement fan with the holes in the wall of the chassis.
7. Secure the fan to the chassis wall using the screws previously set aside.
8. Replace the motherboard and reconnect the fan cable to motherboard.
9. Reinstall the chassis top cover, and power up the system.

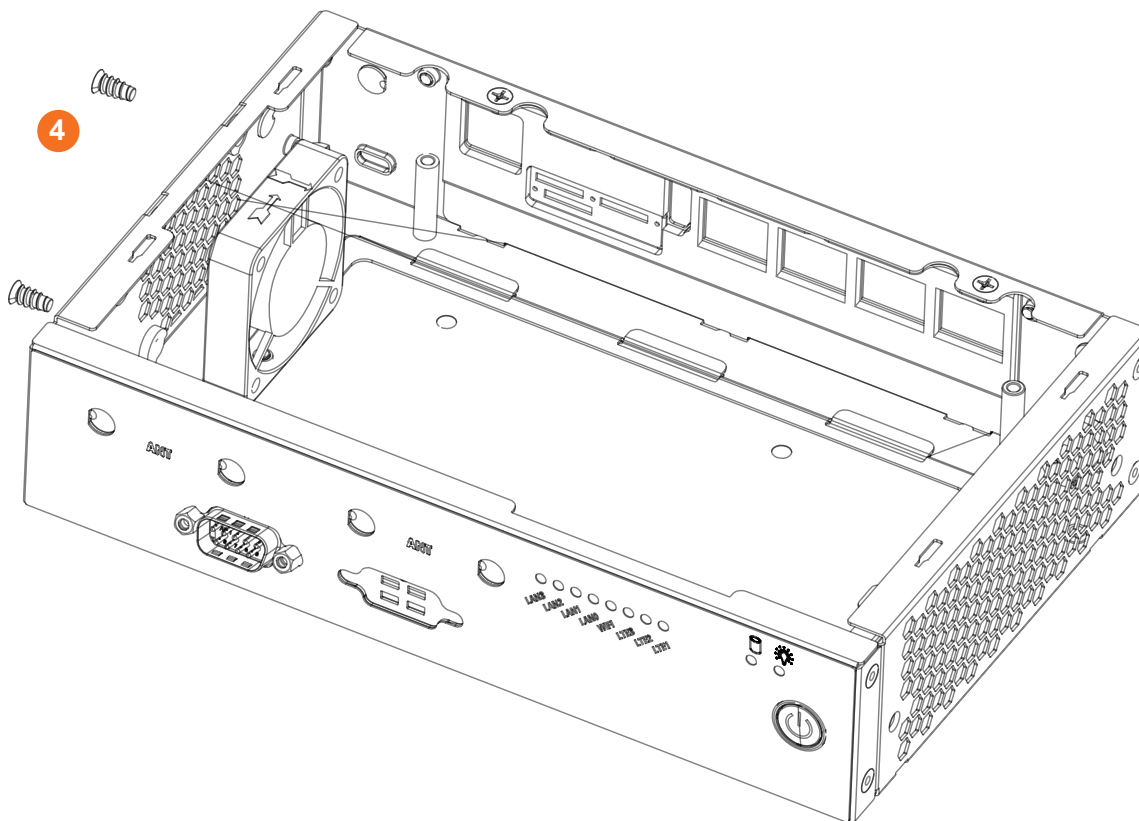

Figure 3-3. System Fan

Chapter 4

Motherboard Connections

This section describes the connections on the A2SAN-LN4-E/-C motherboard and provides pinout definitions. Note that depending on how the system is configured, not all connections are required. The LEDs on the motherboard are also described here. A motherboard layout indicating component locations may be found in [Chapter 1](#). More detail can be found in the [Motherboard Manual](#).

Please review the Safety Precautions in [Appendix A](#) before installing or removing components.

4.1 Power Connections

SATA Power Connector

The 4-pin SATA power connector JPH1 provides power to onboard HDD devices. Refer to the table below for pin definitions.

SATA Power Pin Definitions	
Pin#	Definition
1	12V
2-3	Ground
4	5V

8-Pin Power Connector

JPW1 is an 8-pin 12V DC power input for the CPU that must be connected to the power supply. Refer to the table below for pin definitions.

8-pin Power Pin Definitions	
Pin#	Definition
1 - 4	P12VSB
5 - 8	Ground

4.2 Headers and Connectors

Fan Headers

There is one fan header with 4-pins on the motherboard. Pins 1-3 are backward compatible with traditional 3-pin fans. The onboard fan speeds are controlled by Thermal Management (via Hardware Monitoring) in the BIOS.

Fan Header Pin Definitions	
Pin#	Definition
1	Ground (Black)
2	2.5A/+12V (Red)
3	Tachometer
4	PWM_Control

Speaker

If you wish to use an external speaker, connect a cable to pins 1-4 on the JD1 header. Refer to the table below for pin definitions.

Speaker Connector Pin Definitions	
Pin#	Signal
1	P5V
2	NC
3	NC
4	R_SPKPIN

General Purpose I/O Header

The JGP1 (General Purpose Input/Output) header is a general purpose I/O expander on a pin header via the SMBus. Each pin can be configured to be an input pin or output pin. The GPIO is controlled by the SIO NCT5523D (pins GP20 - GP27). Refer to the table below for pin definitions.

GPIO Header Pin Definitions			
Pin#	Definition	Pin#	Definition
1	P3V3SB	2	GND
3	GP_P3V3_GP0	4	GP_P3V3_GP4
5	GP_P3V3_GP1	6	GP_P3V3_GP5
7	GP_P3V3_GP2	8	GP_P3V3_GP6
9	GP_P3V3_GP3	10	GP_P3V3_GP7

Battery Connector

BT1 is a two-pin connector for an external CMOS battery. This connector is also used to clear the CMOS. To clear the CMOS, remove the battery, short pins 1-2 for more than 10 seconds and then install the battery.

COM Header

The motherboard has one COM header (COM1) that supports RS-232.

COM Header (COM1) Pin Definitions			
Pin#	Description	Pin#	Description
1	DCD	6	DSR
2	RXD	7	RTS
3	TXD	8	CTS
4	DTR	9	RI
5	Ground	10	N/A

SATA Port

The A2SAN-LN4-E/-C motherboard has one I-SATA 3.0 port. Refer to the table below for pin definitions.

SATA 3.0 Port Pin Definitions	
Pin#	Signal
1	Ground
2	SATA_TXP
3	SATA_TXN
4	Ground
5	SATA_RXN
6	SATA_RXP
7	Ground

M.2 Slots

The A2SAN-LN4-E/-C motherboard has four M.2 slots. M.2 was formerly known as Next Generation Form Factor (NGFF). M.2 allows for a variety of card sizes, increased functionality, and spatial efficiency. The M.2 slots at JMD1, JMD2 and JMD3 support B-Key (USB2.0/3.0 with Nano SIM for LTE/3G) modules in a 2242/3042 form factor. JDM1 supports SATA upon request. The M.2 slot at JMD4 supports E-Key (PCIe x1/USB2.0 with WiFi + BT) modules in a 2230 form factor. Refer to the following pages for M.2 pin definition tables.

M.2 Slot Pin Definition for JMD1

M.2 Pin Definition (JMD1)			
Pin#	Definition	Pin#	Definition
1	N/C	2	P3V3SB
3	GND	4	P3V3SB
5	GND	6	FULL_CARD_POWER_OFF#(PU to P1V8SB only)
7	USB_D-	8	W_DISABLE1#(PU to P3V3SB only)
9	USB_D+	10	LED (ACTIVE LOW)
11	GND	12	KEY B
13	KEY B	14	KEY B
15	KEY B	16	KEY B
17	KEY B	18	KEY B
19	KEY B	20	N/C
21	N/C	22	N/C
23	WAKE_ON_WWAN#(PU to P1V8SB only)	24	N/C
25	N/C	26	RF_KILL_GPS#(PU to P1V8SB only)
27	GND	28	N/C
29	USB3.0-Rx-	30	UIM-RESET
31	USB3.0-Rx+	32	UIM-CLK
33	GND	34	UIM-DATA
35	USB3.0-Tx-	36	UIM-PWR
37	USB3.0-Tx+	38	N/C
39	GND	40	SMB_SCL (PU to P1V8SB only)
41	SATA-B+	42	SMB_SDA (PU to P1V8SB only)
43	SATA-B-	44	Alert# (PU to P1V8SB only)
45	GND	46	N/C
47	SATA-A-	48	N/C
49	SATA-A+	50	N/C
51	GND	52	N/C
53	N/C	54	N/C
55	N/C	56	N/C
57	GND	58	N/C
59	N/C	60	N/C
61	N/C	62	N/C
63	N/C	64	N/C
65	N/C	66	SIM_DETECT
67	Reset# (From PCH GPIO)	68	N/C
69	N/C	70	P3V3SB
71	GND	72	P3V3SB
73	GND	74	P3V3SB
75	N/C		

M.2 Slot Pin Definition for JMD2

M.2 Pin Definition (JMD2)			
Pin#	Definition	Pin#	Definition
1	N/C	2	P3V3SB
3	GND	4	P3V3SB
5	GND	6	FULL_CARD_POWER_OFF#(PU to P1V8SB only)
7	USB_D-	8	W_DISABLE1#(PU to P3V3SB only)
9	USB_D+	10	LED (ACTIVE LOW)
11	GND	12	KEY B
13	KEY B	14	KEY B
15	KEY B	16	KEY B
17	KEY B	18	KEY B
19	KEY B	20	N/C
21	N/C	22	N/C
23	WAKE_ON_WWAN#(PU to P1V8SB only)	24	N/C
25	N/C	26	RF_KILL_GPS#(PU to P1V8SB only)
27	GND	28	N/C
29	USB3.0-Rx-	30	UIM-RESET
31	USB3.0-Rx+	32	UIM-CLK
33	GND	34	UIM-DATA
35	USB3.0-Tx-	36	UIM-PWR
37	USB3.0-Tx+	38	N/C
39	GND	40	SMB_SCL (PU to P1V8SB only)
41	N/C	42	SMB_SDA (PU to P1V8SB only)
43	N/C	44	Alert# (PU to P1V8SB only)
45	GND	46	N/C
47	N/C	48	N/C
49	N/C	50	N/C
51	GND	52	N/C
53	N/C	54	N/C
55	N/C	56	N/C
57	GND	58	N/C
59	N/C	60	N/C
61	N/C	62	N/C
63	N/C	64	N/C
65	N/C	66	SIM_DETECT
67	Reset# (From PCH GPIO)	68	N/C
69	N/C	70	P3V3SB
71	GND	72	P3V3SB
73	GND	74	P3V3SB
75	N/C		

M.2 Slot Pin Definition for JMD3

M.2 Pin Definition (JMD3)			
Pin#	Definition	Pin#	Definition
1	N/C	2	P3V3SB
3	GND	4	P3V3SB
5	GND	6	FULL_CARD_POWER_OFF#(PU to P1V8SB only)
7	USB_D-	8	W_DISABLE1#(PU to P3V3SB only)
9	USB_D+	10	LED (ACTIVE LOW)
11	GND	12	KEY B
13	KEY B	14	KEY B
15	KEY B	16	KEY B
17	KEY B	18	KEY B
19	KEY B	20	N/C
21	N/C	22	N/C
23	WAKE_ON_WWAN#(PU to P1V8SB only)	24	N/C
25	N/C	26	RF_KILL_GPS#(PU to P1V8SB only)
27	GND	28	N/C
29	USB3.0-Rx-	30	UIM-RESET
31	USB3.0-Rx+	32	UIM-CLK
33	GND	34	UIM-DATA
35	USB3.0-Tx-	36	UIM-PWR
37	USB3.0-Tx+	38	N/C
39	GND	40	SMB_SCL (PU to P1V8SB only)
41	N/C	42	SMB_SDA (PU to P1V8SB only)
43	N/C	44	Alert# (PU to P1V8SB only)
45	GND	46	N/C
47	N/C	48	N/C
49	N/C	50	N/C
51	GND	52	N/C
53	N/C	54	N/C
55	N/C	56	N/C
57	GND	58	N/C
59	N/C	60	N/C
61	N/C	62	N/C
63	N/C	64	N/C
65	N/C	66	SIM_DETECT
67	Reset# (From PCH GPIO)	68	N/C
69	N/C	70	P3V3SB
71	GND	72	P3V3SB
73	GND	74	P3V3SB
75	N/C		

M.2 Slot Pin Definition for JMD4

M.2 Pin Definition (JMD4)			
Pin#	Definition	Pin#	Definition
1	GND	2	P3V3SB
3	USB_D+	4	P3V3SB
5	USB_D-	6	NGFF_WIFI_LED (ACTIVE LOW)
7	GND	8	N/C
9	N/C	10	N/C
11	N/C	12	N/C
13	N/C	14	N/C
15	N/C	16	N/C
17	N/C	18	GND
19	GND	20	NGFF_CONN_UART_WAKE_N (PU to P3V3SB only)
21	N/C	22	N/C
23	N/C	24	KEY E
25	KEY E	26	KEY E
27	KEY E	28	KEY E
29	KEY E	30	KEY E
31	KEY E	32	N/C
33	GND	34	N/C
35	PETp0	36	N/C
37	PETn0	38	N/C
39	GND	40	N/C
41	PERp0	42	N/C
43	PERn0	44	N/C
45	GND	46	N/C
47	REFCLKp0	48	N/C
49	REFCLKn0	50	N/C
51	GND	52	PERST0#
53	N/C	54	NGFF_3P3_KILL_BT_N (PU to P3V3SB only)
55	PEWAKE0#	56	WIFI_DISABLE2#
57	GND	58	N/C
59	N/C	60	N/C
61	N/C	62	N/C
63	GND	64	N/C
65	N/C	66	N/C
67	N/C	68	N/C
69	GND	70	N/C
71	N/C	72	P3V3SB
73	N/C	74	P3V3SB
75	GND		

System Management Bus Header

A System Management Bus header for additional slave devices or sensors is located at JSMBUS1. Refer to the table below for pin definitions.

SMBus Header Pin Definitions	
Pin#	Definition
1	Data
2	Ground
3	Clock
4	NC

Control Panel

JF1 contains header pins for various buttons and indicators that are normally located on a control panel at the front of the chassis. These connectors are designed specifically for use with Supermicro chassis. See the figure below for the descriptions of the front control panel buttons and LED indicators.

Power Button

The Power Button connection is located on pins 1 and 2 of JF1. Momentarily contacting both pins will power on/off the system. This button can also be configured to function as a suspend button (with a setting in the BIOS - see Chapter 4). To turn off the power when the system is in suspend mode, press the button for 4 seconds or longer. Refer to the table below for pin definitions.

Power Button Pin Definitions (JF1)	
Pin#	Definition
1	Signal
2	Ground

Reset Button

The Reset Button connection is located on pins 3 and 4 of JF1. Attach it to a hardware reset switch on the computer case to reset the system. Refer to the table below for pin definitions.

Reset Button Pin Definitions (JF1)	
Pin#	Definition
3	Reset
4	Ground

HDD LED

The HDD LED connection is located on pins 5 and 6 of JF1. Attach a cable here to indicate the status of HDD-related activities, including SATA activities. Refer to the table below for pin definitions.

HDD LED Pin Definitions (JF1)	
Pin#	Definition
5	+3.3V
6	HDD Active LED

Power LED

The Power LED connection is located on pins 7 and 8 of JF1. Refer to the table below for pin definitions.

Power LED Pin Definitions (JF1)	
Pin#	Definition
7	+3.3VSB
8	Power LED Low

4.3 Input/Output Ports

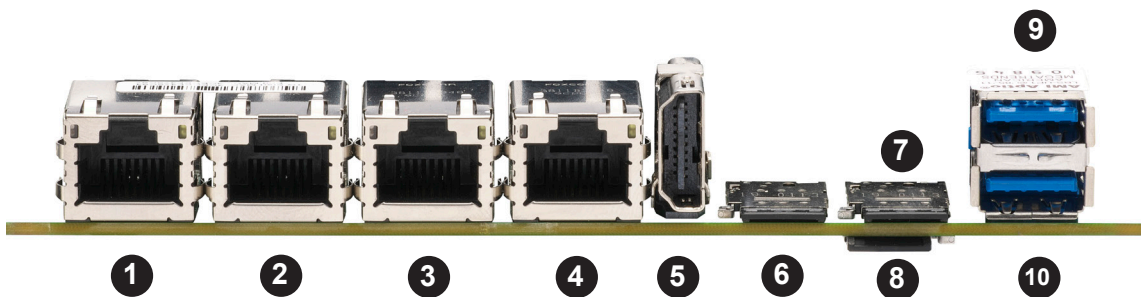

Rear I/O Ports			
#	Definition	#	Description
1	LAN1	6	SIM Slot 1 (JMD1)
2	LAN2	7	SIM Slot 2 (JMD2)
3	LAN3	8	SIM Slot 3 (JMD3)
4	LAN4	9	USB1
5	HDMI Port	10	USB0

HDMI Port

The HDMI (High-Definition Multimedia Interface) port is used to display both high definition video and digital sound through an HDMI-capable display, using an HDMI cable.

Universal Serial Bus (USB) Ports

There are two USB 3.0 ports (USB0/1) located on the I/O back panel. J2 is a front accessible USB 2.0 header.

Back Panel USB 3.0 (0/1) Pin Definitions			
Pin#	Definition	Pin#	Definition
A1	VBUS	B1	VBUS
A2	D1-N	B2	D2-N
A3	D1-P	B3	D2-P
A4	GND	B4	GND
A5	Stda_SSRX1-N	B5	Stda_SSRX2-N
A6	Stda_SSRX1-P	B6	Stda_SSRX2-P
A7	GND_DRAIN	B7	GND_DRAIN
A8	Stda_SSTX1-N	B8	Stda_SSTX2-N
A9	Stda_SSTX1-P	B9	Stda_SSTX2-P

Front Panel USB 2.0 Header Header Pin Definitions			
Pin#	Definition	Pin#	Definition
1	P5V_DUAL_F	2	P5V_DUAL_F
3	USBCON_N2	4	USBCON_N3
5	USBCON_P2	6	USBCON_P3
7	Ground	8	Ground
9		10	NC

Nano SIM Slots

There are two Nano SIM card slots on the I/O back panel. Nano SIM slot 1 is for JMD1 and Nano SIM slot 2 is for JDM2. Nano SIM slot 3 (JMD3) on the bottom of the motherboard

LAN Ports

Four Gigabit Ethernet ports (LAN1 - LAN4) are located on the I/O back panel. All of these ports accept RJ45 cables. Please refer to the LED Indicator section for LAN LED information.

LAN Port Pin Definition			
Pin#	Definition	Pin#	Definition
1	TD0-	11	P3V3_Dual
2	TD0+	12	Act LED (Yellow)
3	TD1-	13	Link 1000 (Amber)
4	TD1+	14	Link 100 LED (Green)
5	TD2-	15	GND
6	TD2+	16	GND
7	TD3-	17	GND
8	TD3+	18	GND
9	COMMCT		
10	GND		

4.4 Jumpers

How Jumpers Work

To modify the operation of the motherboard, jumpers can be used to choose between optional settings. Jumpers create shorts between two pins to change the function of the connector. Pin 1 is identified with a square solder pad on the printed circuit board. See the diagram below for an example of jumping pins 1 and 2. Refer to the motherboard layout page for jumper locations.

Note: On two-pin jumpers, Closed means the jumper is on the pins and Open means the jumper is off.

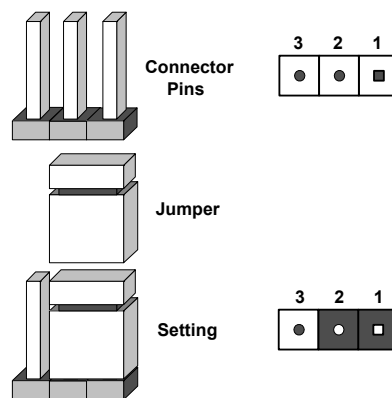

ME Manufacturing Mode and Power Force On

The JPME2 jumper has two functions: Manufacturing Mode and Power Force On. Refer to the table below for the jumper settings for each function. The asterisk represents the default setting.

Manufacturing Mode/Power Force On Jumper Settings	
Jumper Setting	Definition
Pins 1-3	Manufacturing Mode
Pins 3-5	Normal*
Pins 2-4	Power Force On*
Pins 4-6	PWR Button Power On

SIM Card Detection

JSIM_OPT1 is the SIM card detection jumper. The default setting is Closed: Low Active. Refer to the table below the set the correct jumper setting for JSIM1, JSIM2, and JSIM3.

SIM Card Detection Jumper Settings	
Jumper Setting	Definition
Pins 1-2 (JSIM1)	
Pins 3-4 (JSIM2)	Open: High Active Closed: Low Active
Pins 5-6 (JSIM3)	

4.5 LED Indicators

LAN LEDs

Four LAN ports (LAN 1 and LAN 2) are located on the I/O back panel of the motherboard. Each LAN port has two LEDs. The green LED indicates activity, while the other Link LED may be green, amber, or off to indicate the speed of the connection. Refer to the tables below for more information.

LAN Activity LED (Right) LED State		
Color	Status	Definition
Amber	Flashing	Active

LAN Link LED (Left) LED State	
LED Color	Definition
Green	100Mbps
Yellow/Amber	1Gbps

Power LED

LED1 is the Power GOOD LED. Refer to the table below for LED definitions.

Power Good LED Indicator	
LED Color	Definition
Green	All power is good
Red	Issue with power output

M.2 Active LED

LED2, LED3, LED4, and LED5 are the M.2 activity LEDs. The LED activity behavior depends on the module.

M.2 Active LED Indicator	
LED Color	Definition
Depends on the Module	M.2 Module Active

LAN Activity LED

LED6, LED7, LED8, and LED9 are the GbE LAN activity LEDs. When the LED is blinking amber, there is activity on the LAN port(s).

GbE LAN Active LED Indicator	
LED Color	Definition
Blinking Amber	LAN Active

Chapter 5

Software

After the hardware has been installed, you can install the Operating System (OS), configure RAID settings and install the drivers.

5.1 Microsoft Windows OS Installation

If you will be using RAID, you must configure RAID settings before installing the Windows OS and the RAID driver. Refer to the RAID Configuration User Guides posted on our website at www.supernmicro.com/support/manuals.

Installing the OS

1. Create a method to access the MS Windows installation ISO file. That might be a DVD, perhaps using an external USB/SATA DVD drive, or a USB flash drive, or the IPMI KVM console.
2. Retrieve the proper RST/RSTe driver. Go to the Supermicro web page for your motherboard and click on "Download the Latest Drivers and Utilities", select the proper driver, and copy it to a USB flash drive.
3. Boot from a bootable device with Windows OS installation. You can see a bootable device list by pressing **F11** during the system startup.

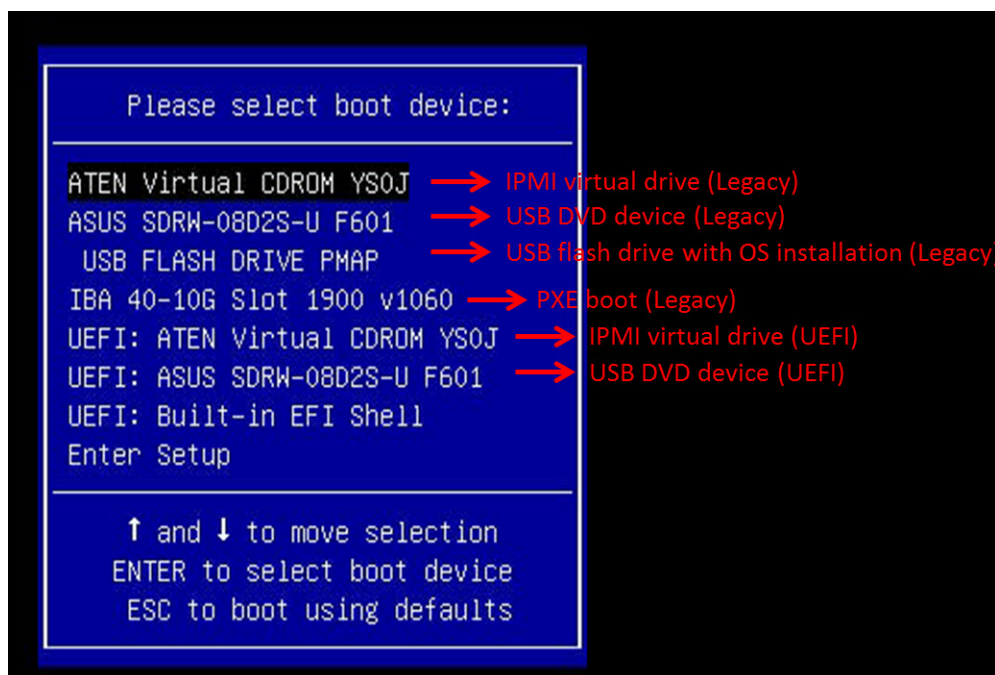

Figure 5-1. Select Boot Device

4. During Windows Setup, continue to the dialog where you select the drives on which to install Windows. If the disk you want to use is not listed, click on “Load driver” link at the bottom left corner.

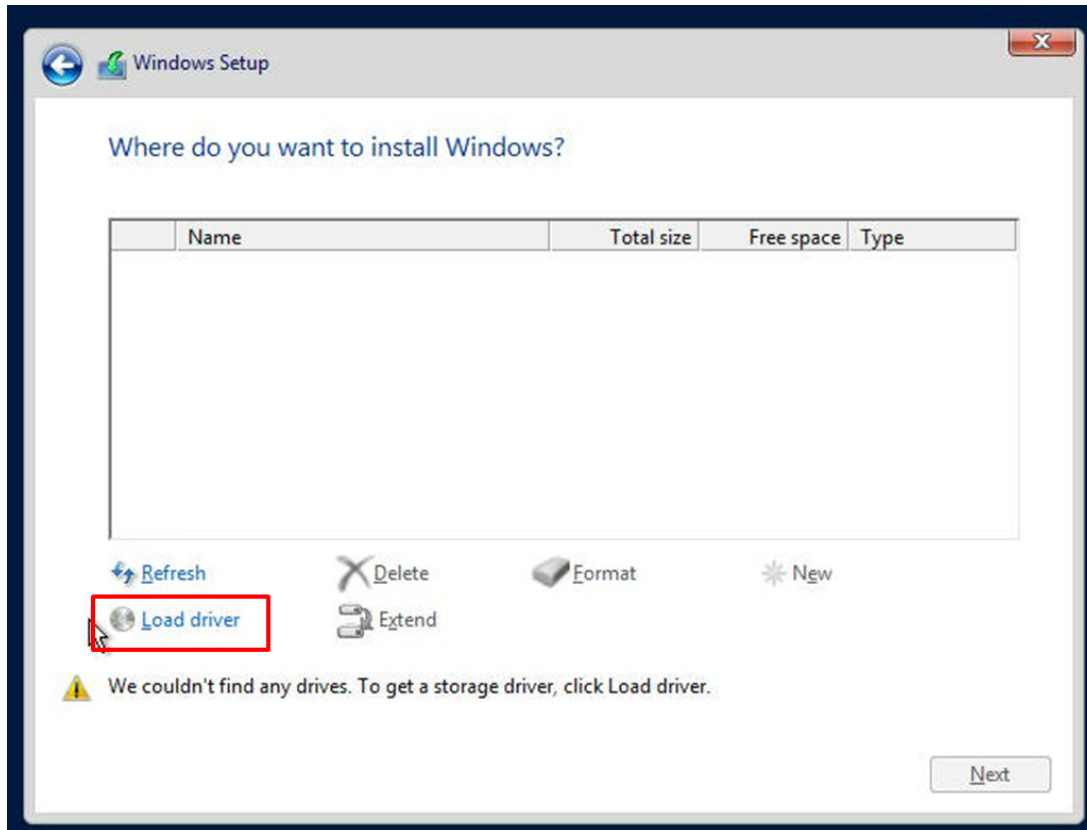

Figure 5-2. Load Driver Link

To load the driver, browse the USB flash drive for the proper driver files.

- For RAID, choose the SATA/sSATA RAID driver indicated then choose the storage drive on which you want to install it.
 - For non-RAID, choose the SATA/sSATA AHCI driver indicated then choose the storage drive on which you want to install it.
5. Once all devices are specified, continue with the installation.
 6. After the Windows OS installation has completed, the system will automatically reboot multiple times.

5.2 Driver Installation

The Supermicro website contains drivers and utilities for your system at <https://www.supermicro.com/wdl/driver>. Some of these must be installed, such as the chipset driver.

After accessing the website, go into the CDR_Images (in the parent directory of the above link) and locate the ISO file for your motherboard. Download this file to to a USB flash drive or a DVD. (You may also use a utility to extract the ISO file if preferred.)

After creating a CD/DVD with the ISO files, insert the disk into the CD/DVD drive on your system and the display shown in Figure B-1 should appear.

Another option is to go to the Supermicro website at <http://www.supermicro.com>. Find the product page for your motherboard, and "Download the Latest Drivers and Utilities".

Insert the flash drive or disk and the screenshot shown below should appear.

Note: To install the Windows OS, please refer to the instructions posted on our website at <http://www.supermicro.com/support/manuals/>.

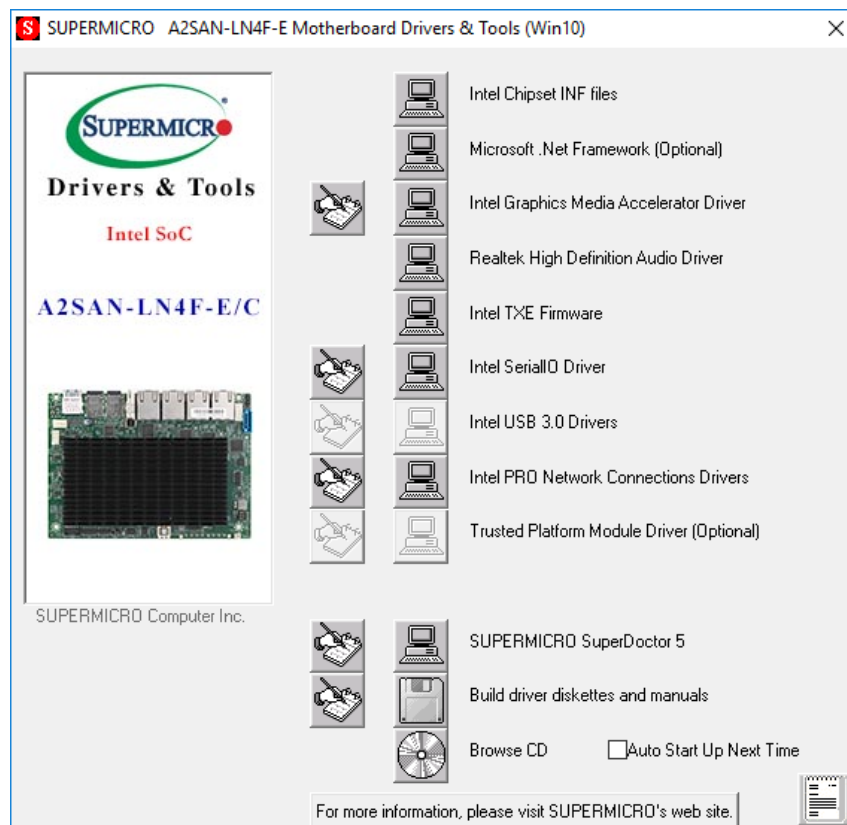

Figure 5-3. Driver & Tool Installation Screen

Note: Click the icons showing a hand writing on paper to view the readme files for each item. Click the computer icons to the right of these items to install each item (from top to the bottom) one at a time. **After installing each item, you must reboot the system before moving on to the next item on the list.** The bottom icon with a CD on it allows you to view the entire contents.

5.3 SuperDoctor® 5

The Supermicro SuperDoctor 5 is a program that functions in a command-line or web-based interface for Windows and Linux operating systems. The program monitors such system health information as CPU temperature, system voltages, system power consumption, fan speed, and provides alerts via email or Simple Network Management Protocol (SNMP).

SuperDoctor 5 comes in local and remote management versions and can be used with Nagios to maximize your system monitoring needs. With SuperDoctor 5 Management Server (SSM Server), you can remotely control power on/off and reset chassis intrusion for multiple systems with SuperDoctor 5. SuperDoctor 5 Management Server monitors HTTP, FTP, and SMTP services to optimize the efficiency of your operation.

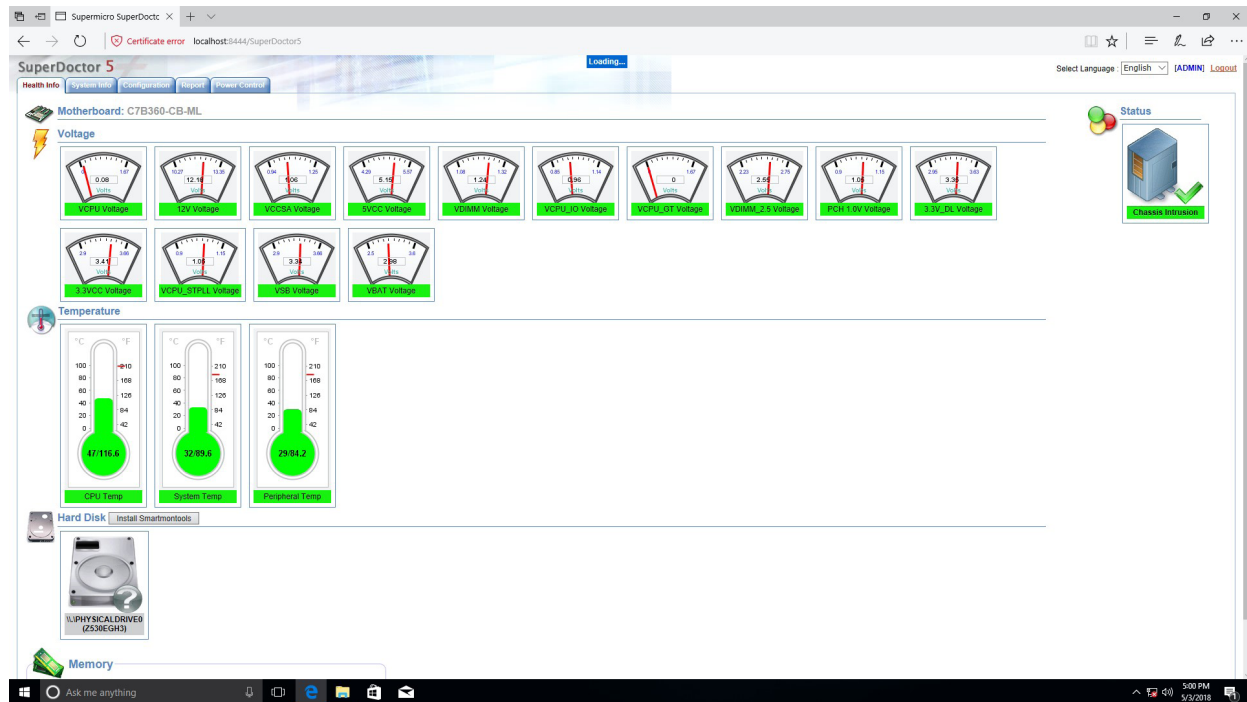

Figure 5-4. SuperDoctor 5 Interface Display Screen (Health Information)

5.4 IPMI

The A2SAN-LN4-E/-C supports the Intelligent Platform Management Interface (IPMI). IPMI provides remote access, monitoring and management through the baseboard management controller (BMC) and other management controllers distributed among different system modules. There are several BIOS settings that are related to IPMI. For general documentation and information on IPMI, visit our website at: <http://www.supermicro.com/products/nfo/IPMI.cfm>.

BMC ADMIN User Password

For security, each system is assigned a unique default BMC password for the ADMIN user. This can be found on a sticker on the chassis and a sticker on the motherboard. The sticker also displays the BMC MAC address.



Figure 5-5. BMC Password Label

Chapter 6

Troubleshooting and Support

6.1 Information Resources

Website

A great deal of information is available on the Supermicro [website](#).

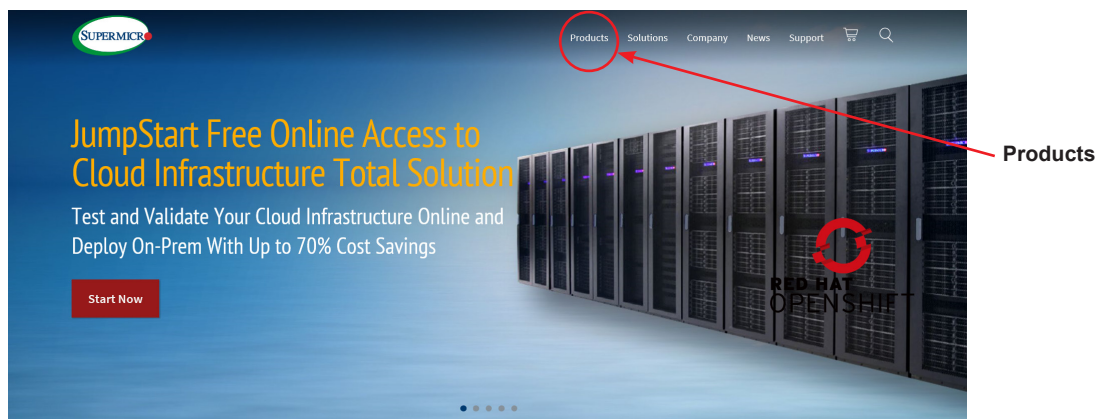

Figure 7-1. Supermicro Website

- Specifications for servers and other hardware are available by clicking the **Products**.
- The **Support** option offers downloads (manuals, BIOS/BMC, drivers, etc.), FAQs, RMA, warranty, and other service extensions.

Direct Links for the SYS-E102-9AP-LN4-E/-C System

[SYS-E102-9AP-LN4-E/-C specifications page](#)

[A2SAN-LN4-E/-C motherboard page](#) for links to the Quick Reference Guide, User Manual, validated storage drives, etc.

Direct Links for General Support and Information

[Frequently Asked Questions](#)

[Add-on card descriptions](#)

[TPM User Guide](#)

General Memory Configuration Guide: [X12](#)

[IPMI User Guide](#)

Direct Links (continued)

SuperDoctor5 Large Deployment Guide

For validated memory, use our [Product Resources](#) page

[Product Matrices](#) page for links to tables summarizing specs for systems, motherboards, power supplies, riser cards, add-on cards, etc.

[Security Center](#) for recent security notices

[Supermicro Phone and Addresses](#)

6.2 Intelligent Platform Management Interface (IPMI)

The system supports the Intelligent Platform Management Interface (IPMI). IPMI is used to provide remote access, monitoring and management. There are several BIOS settings that are related to IPMI.

For general documentation and information on IPMI, please visit our website at: <http://www.supermicro.com/products/nfo/IPMI.cfm>.

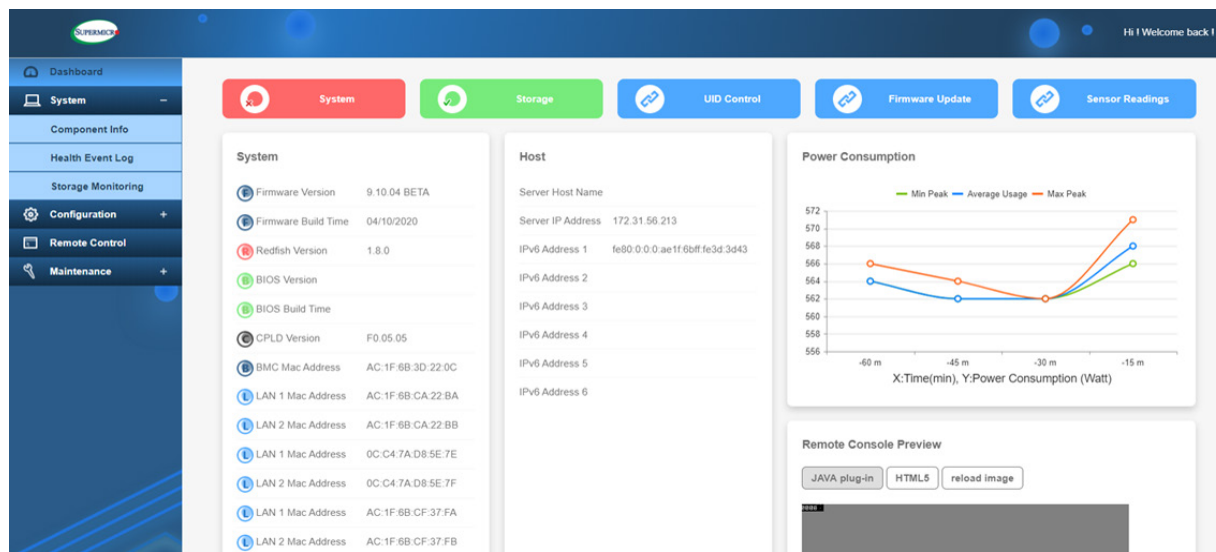

Figure 7-2. IPMI Sample

6.3 Troubleshooting Procedures

Use the following procedures to troubleshoot your system. If you have followed all of the procedures below and still need assistance, refer to the [Technical Support Procedures](#) or [Returning Merchandise for Service](#) section(s) in this chapter. **Power down** the system before changing any non hot-swap hardware components.

No Power

1. As you try to power up the system, note any beep codes. Refer to the next section for details on [beep codes](#).
2. Check that the power LED on the motherboard is on.

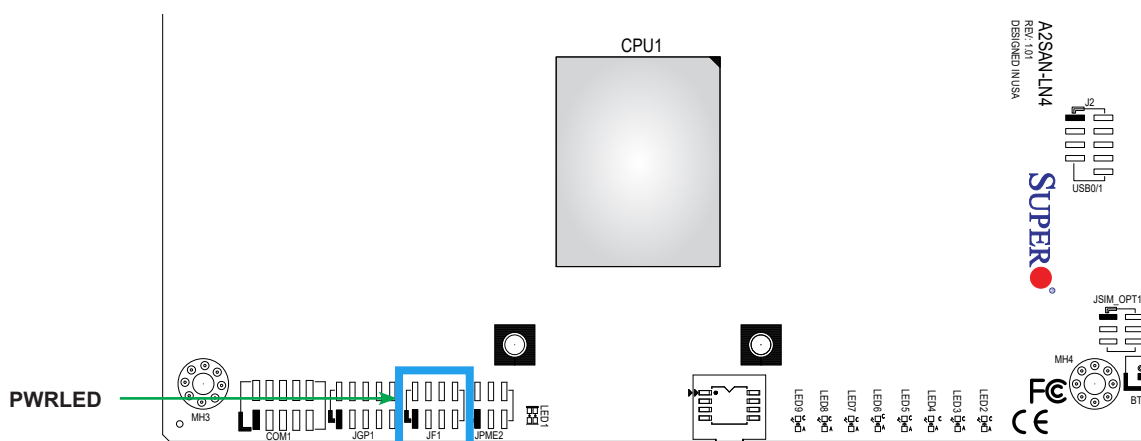

Figure 7-3. Location of the MB Power LED

3. Make sure that the power connector is connected to your power supply.
4. Make sure that no short circuits exist between the motherboard and chassis.
5. Disconnect all cables from the motherboard, including those for the keyboard and mouse.
6. Remove all add-on cards.
7. Connect the internal speaker (if applicable), and the power LED to the motherboard. Make sure that the heatsink is fully seated.
8. Use the correct type of onboard CMOS battery as recommended by the manufacturer. Check to verify that it still supplies ~3VDC. If it does not, replace it with a new one.
Warning: To avoid possible explosion, do not install the battery upside down.
9. Verify that all jumpers are set to their default positions.
10. Check that the power supplies' input voltage operate at 100-120v or 180-240v.
11. Turn the power switch on and off to test the system

No Video

1. If the power is on but you have no video, remove all the add-on cards and cables.
2. As you try to power up the system, note any beep codes. Refer to the next section for details on [beep codes](#).

System Boot Failure

If the system does not display POST (Power-On-Self-Test) or does not respond after the power is turned on, check the following:

Turn on the system with only one DIMM module installed. If the system boots, check for a bad DIMM module or slot by following the Memory Errors Troubleshooting procedure below.

Memory Errors

1. Make sure that the DIMM module is properly and fully installed.
2. Confirm that you are using the correct memory. Also, it is recommended that you use the same memory type and speed for the DIMM in the system. See Section 3.3 for memory details.
3. Check for a bad DIMM module or slot by swapping the module between slots and noting the results.
4. Check the power supply voltage 115V/230V switch.

Losing the System's Setup Configuration

1. Make sure that you are using a high quality power supply. A poor quality power supply may cause the system to lose the CMOS setup information. .
2. The battery on your motherboard may be old. Check to verify that it still supplies ~3VDC. If it does not, replace it with a new one.
3. If the above steps do not fix the setup configuration problem, contact your vendor for repairs.

When the System Becomes Unstable

If the system becomes unstable during or after OS installation, check the following:

1. CPU/BIOS support: Make sure that you have the latest BIOS installed in your system.
2. Memory support: Make sure that the memory module is supported by testing the module using memtest86 or a similar utility.

Note: Refer to the product page on our website at <http://www.supernmicro.com> for memory and CPU support and updates.

3. HDD support: Make sure that all hard disk drives (HDDs) work properly. Replace the bad HDDs with good ones.
4. System cooling: Check the system cooling to make sure that all heatsink fans and CPU/system fans, etc., work properly. Check the hardware monitoring settings in the IPMI to make sure that the CPU and system temperatures are within the normal range. Also check the front panel Overheat LED and make sure that it is not on.
5. Adequate power supply: Make sure that the power supply provides adequate power to the system. Make sure that all power connectors are connected. Please refer to our website for more information on the minimum power requirements.
6. Proper software support: Make sure that the correct drivers are used.

If the system becomes unstable before or during OS installation, check the following:

1. Source of installation: Make sure that the devices used for installation are working properly, including boot devices such as CD.
2. Cable connection: Check to make sure that all cables are connected and working properly.
3. Using the minimum configuration for troubleshooting: Remove all unnecessary components (starting with add-on cards first), and use the minimum configuration (but with a CPU and a memory module installed) to identify the trouble areas. Refer to the steps listed in Section A above for proper troubleshooting procedures.
4. Identifying bad components by isolating them: If necessary, remove a component in question from the chassis, and test it in isolation to make sure that it works properly. Replace a bad component with a good one.
5. Check and change one component at a time instead of changing several items at the same time. This will help isolate and identify the problem.
6. To find out if a component is good, swap this component with a new one to see if the system will work properly. If so, then the old component is bad. You can also install the component in question in another system. If the new system works, the component is good and the old system has problems.

6.4 BIOS Error Beep (POST) Codes

During the POST (Power-On Self-Test) routines, which are performed each time the system is powered on, errors may occur.

Non-fatal errors are those which, in most cases, allow the system to continue the boot-up process. The error messages normally appear on the screen.

Fatal errors are those which will not allow the system to continue the boot-up procedure. If a fatal error occurs, you should consult with your system manufacturer for possible repairs.

These fatal errors are usually communicated through a series of audible beeps. The table below lists some common errors and their corresponding beep codes encountered by users.

BIOS Error Beep (POST) Codes		
Beep Code	Error Message	Description
1 short	Refresh	Circuits have been reset (Ready to power up)
5 short, 1 long	Memory error	No memory detected in system
5 long, 2 short	Display memory read/write error	Video adapter missing or with faulty memory
1 long continuous	System OH	System overheat condition

Additional BIOS POST Codes

The AMI BIOS supplies additional checkpoint codes, which are documented online at <http://www.supermicro.com/support/manuals/> ("AMI BIOS POST Codes User's Guide").

When BIOS performs the Power On Self Test, it writes checkpoint codes to I/O port 0080h. If the computer cannot complete the boot process, a diagnostic card can be attached to the computer to read I/O port 0080h (Supermicro p/n AOC-LPC80-20).

For information on AMI updates, please refer to <http://www.ami.com/products/>.

6.5 Crash Dump Using IPMI

In the event of a processor internal error (IERR) that crashes your system, you may want to provide information to support staff. You can download a crash dump of status information using IPMI. The IPMI manual is available at <https://www.supernmicro.com/solutions/IPMI.cfm>.

Check IPMI Error Log

1. Access the IPMI web interface.
2. Click the **System** tab, then **Health Event Log** to verify an IERR error.

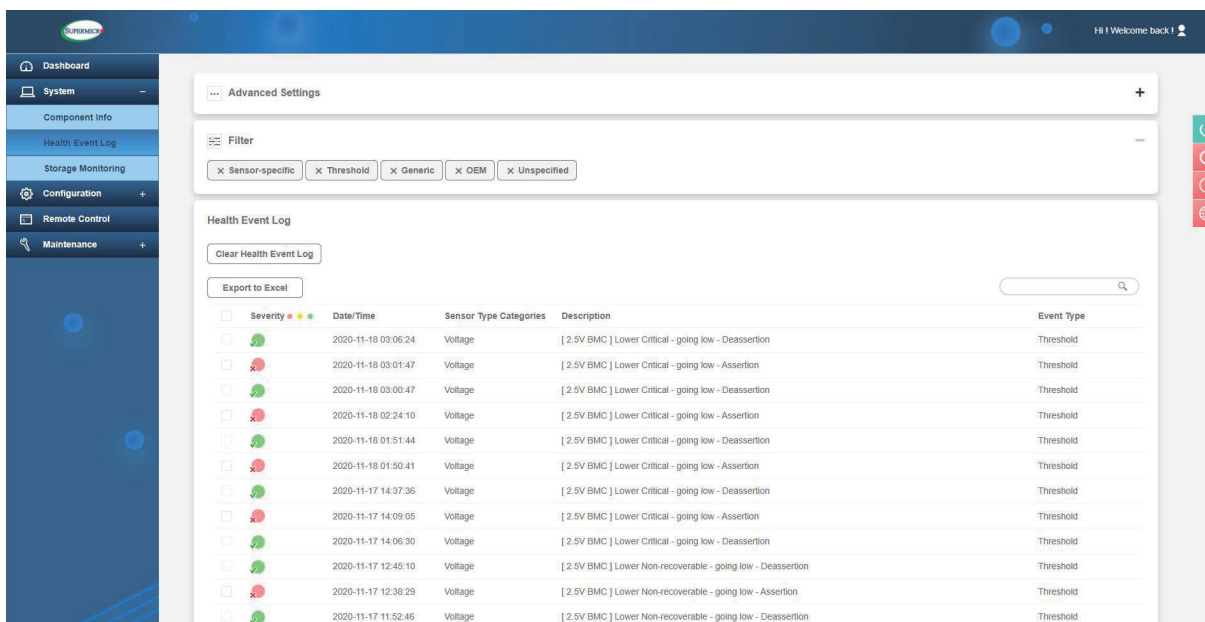

The screenshot shows the IPMI web interface with the 'Health Event Log' tab selected. The interface includes a sidebar with navigation options like Dashboard, System, Component Info, Health Event Log, Storage Monitoring, Configuration, Remote Control, and Maintenance. The main content area displays a table of health events with the following columns: Severity (indicated by colored dots), Date/Time, Sensor Type Categories, Description, and Event Type. The table contains 14 rows of data, all related to voltage sensors and threshold events.

Severity	Date/Time	Sensor Type Categories	Description	Event Type
Green	2020-11-18 03:06:24	Voltage	[2.5V BMC] Lower Critical - going low - Deassertion	Threshold
Red	2020-11-18 03:01:47	Voltage	[2.5V BMC] Lower Critical - going low - Assertion	Threshold
Green	2020-11-18 03:00:47	Voltage	[2.5V BMC] Lower Critical - going low - Deassertion	Threshold
Red	2020-11-18 02:24:10	Voltage	[2.5V BMC] Lower Critical - going low - Assertion	Threshold
Green	2020-11-18 01:51:44	Voltage	[2.5V BMC] Lower Critical - going low - Deassertion	Threshold
Red	2020-11-18 01:50:41	Voltage	[2.5V BMC] Lower Critical - going low - Assertion	Threshold
Green	2020-11-17 14:37:36	Voltage	[2.5V BMC] Lower Critical - going low - Deassertion	Threshold
Red	2020-11-17 14:09:05	Voltage	[2.5V BMC] Lower Critical - going low - Assertion	Threshold
Green	2020-11-17 14:06:30	Voltage	[2.5V BMC] Lower Critical - going low - Deassertion	Threshold
Green	2020-11-17 12:45:10	Voltage	[2.5V BMC] Lower Non-recoverable - going low - Deassertion	Threshold
Red	2020-11-17 12:38:29	Voltage	[2.5V BMC] Lower Non-recoverable - going low - Assertion	Threshold
Green	2020-11-17 11:52:46	Voltage	[2.5V BMC] Lower Non-recoverable - going low - Deassertion	Threshold

Figure 7-4. IPMI Event Log

In the event of an IERR, the BMC executes a crash dump. You must download the crash dump and save it.

6.6 CMOS Clear

JBT1 is used to clear CMOS, which will also clear any passwords. Instead of pins, this jumper consists of contact pads to prevent accidentally clearing the contents of CMOS.

To Clear CMOS

1. First **power down** the system completely.
2. **Remove the cover** of the chassis to access the motherboard.
3. **Remove the onboard battery** from the motherboard.
4. Short the CMOS pads with a metal object such as a small screwdriver for at least four seconds.
5. Remove the screwdriver or shorting device.
6. Replace the cover, reconnect the power cords and power on the system.

Notes: Clearing CMOS will also clear all passwords.

Do not use the PW_ON connector to clear CMOS.



JBT1 contact pads

6.7 Where to Get Replacement Components

If you need replacement parts for your system, to ensure the highest level of professional service and technical support, purchase exclusively from our Supermicro Authorized Distributors/System Integrators/Resellers. A list can be found at: <http://www.supermicro.com>. Click the "Where to Buy" tab.

6.8 Reporting an Issue

Technical Support Procedures

Before contacting Technical Support, please take the following steps. If your system was purchased through a distributor or reseller, please contact them for troubleshooting services. They have the best knowledge of your specific system configuration.

1. Please review the [Troubleshooting Procedures](#) in this manual and [Frequently Asked Questions](#) on our website before contacting Technical Support.
2. BIOS upgrades can be downloaded from our website. **Note:** Not all BIOS can be flashed depending on the modifications to the boot block code.
3. If you still cannot resolve the problem, include the following information when contacting us for technical support:
 - System, motherboard, and chassis model numbers and PCB revision number
 - BIOS release date/version (this can be seen on the initial display when your system first boots up)
 - System configuration

An example of a Technical Support form is posted on our [website](#). Distributors: For immediate assistance, please have your account number ready when contacting our technical support department by email.

Returning Merchandise for Service

A receipt or copy of your invoice marked with the date of purchase is required before any warranty service will be rendered. You can obtain service by calling your vendor for a Returned Merchandise Authorization (RMA) number. When returning to the manufacturer, the RMA number should be prominently displayed on the outside of the shipping carton, and mailed prepaid or hand-carried. Shipping and handling charges will be applied for all orders that must be mailed when service is complete.

For faster service, RMA authorizations may be requested online (<http://www.supermicro.com/support/rma/>).

Whenever possible, repack the chassis in the original Supermicro carton, using the original packaging material. If these are no longer available, be sure to pack the chassis securely, using packaging material to surround the chassis so that it does not shift within the carton and become damaged during shipping.

This warranty only covers normal consumer use and does not cover damages incurred in shipping or from failure due to the alteration, misuse, abuse or improper maintenance of products.

During the warranty period, contact your distributor first for any product problems.

Vendor Support Filing System

For issues related to Intel, use the Intel IPS filing system:

<https://www.intel.com/content/www/us/en/design/support/ips/training/welcome.html>

For issues related to Red Hat Enterprise Linux, since it is a subscription based OS, contact your account representative.

6.9 Feedback

Supermicro values your feedback as we strive to improve our customer experience in all facets of our business. Please email us at techwriterteam@supermicro.com to provide feedback on our manuals.

6.10 Contacting Supermicro

Headquarters

Address: Super Micro Computer, Inc.
980 Rock Ave.
San Jose, CA 95131 U.S.A.

Tel: +1 (408) 503-8000

Fax: +1 (408) 503-8008

Email: marketing@supermicro.com (General Information)
Sales-USA@supermicro.com (Sales Inquiries)
Government_Sales-USA@supermicro.com (Gov. Sales Inquiries)
support@supermicro.com (Technical Support)
RMA@supermicro.com (RMA Support)
Webmaster@supermicro.com (Webmaster)

Website: www.supermicro.com

Europe

Address: Super Micro Computer B.V.
Het Sterrenbeeld 28, 5215 ML
's-Hertogenbosch, The Netherlands

Tel: +31 (0) 73-6400390

Fax: +31 (0) 73-6416525

Email: Sales_Europe@supermicro.com (Sales Inquiries)
Support_Europe@supermicro.com (Technical Support)
RMA_Europe@supermicro.com (RMA Support)

Website: www.supermicro.nl

Asia-Pacific

Address: Super Micro Computer, Inc.
3F, No. 150, Jian 1st Rd.
Zhonghe Dist., New Taipei City 235
Taiwan (R.O.C)

Tel: +886-(2) 8226-3990

Fax: +886-(2) 8226-3992

Email: Sales-Asia@supermicro.com.tw (Sales Inquiries)
Support@supermicro.com.tw (Technical Support)
RMA@supermicro.com.tw (RMA Support)

Website: www.supermicro.com.tw

Appendix A

Standardized Warning Statements for AC Systems

About Standardized Warning Statements

The following statements are industry standard warnings, provided to warn the user of situations which have the potential for bodily injury. Should you have questions or experience difficulty, contact Supermicro's Technical Support department for assistance. Only certified technicians should attempt to install or configure components.

Read this appendix in its entirety before installing or configuring components in the Supermicro chassis.

These warnings may also be found on our website at http://www.supermicro.com/about/policies/safety_information.cfm.

Warning Definition



Warning! This warning symbol means danger. You are in a situation that could cause bodily injury. Before you work on any equipment, be aware of the hazards involved with electrical circuitry and be familiar with standard practices for preventing accidents.

警告の定義

この警告サインは危険を意味します。

人身事故につながる可能性がありますので、いずれの機器でも動作させる前に、電気回路に含まれる危険性に注意して、標準的な事故防止策に精通して下さい。

此警告符号代表危險。

您正处于可能受到严重伤害的工作环境中。在您使用设备开始工作之前，必须充分意识到触电的危险，并熟练掌握防止事故发生的标准工作程序。请根据每项警告结尾的声明号码找到此设备的安全性警告说明的翻译文本。

此警告符號代表危險。

您正處於可能身體可能會受損傷的工作環境中。在您使用任何設備之前，請注意觸電的危險，並且要熟悉預防事故發生的標準工作程序。請依照每一注意事項後的號碼找到相關的翻譯說明內容。

Warnung

WICHTIGE SICHERHEITSHINWEISE

Dieses Warnsymbol bedeutet Gefahr. Sie befinden sich in einer Situation, die zu Verletzungen führen kann. Machen Sie sich vor der Arbeit mit Geräten mit den Gefahren elektrischer Schaltungen und den üblichen Verfahren zur Vorbeugung vor Unfällen vertraut. Suchen Sie mit der am Ende jeder Warnung angegebenen Anweisungsnummer nach der jeweiligen Übersetzung in den übersetzten Sicherheitshinweisen, die zusammen mit diesem Gerät ausgeliefert wurden.

BEWAHREN SIE DIESE HINWEISE GUT AUF.

INSTRUCCIONES IMPORTANTES DE SEGURIDAD

Este símbolo de aviso indica peligro. Existe riesgo para su integridad física. Antes de manipular cualquier equipo, considere los riesgos de la corriente eléctrica y familiarícese con los procedimientos estándar de prevención de accidentes. Al final de cada advertencia encontrará el número que le ayudará a encontrar el texto traducido en el apartado de traducciones que acompaña a este dispositivo.

GUARDE ESTAS INSTRUCCIONES.

IMPORTANTES INFORMATIONS DE SÉCURITÉ

Ce symbole d'avertissement indique un danger. Vous vous trouvez dans une situation pouvant entraîner des blessures ou des dommages corporels. Avant de travailler sur un équipement, soyez conscient des dangers liés aux circuits électriques et familiarisez-vous avec les procédures couramment utilisées pour éviter les accidents. Pour prendre connaissance des traductions des avertissements figurant dans les consignes de sécurité traduites qui accompagnent cet appareil, référez-vous au numéro de l'instruction situé à la fin de chaque avertissement.

CONSERVEZ CES INFORMATIONS.

תקנון הזהרות אזהרה

הזהרות הבאות הן אזהרות על פי תקני התעשייה, על מנת להזהיר את המשתמש מפני חבלה פיזית אפשרית. במידה ויש שאלות או היתקלות בבעיה כלשהי, יש ליצור קשר עם מחלקת תמיכה טכנית של סופרמיקרו. טכנאים מוסמכים בלבד רשאים להתקין או להגדיר את הרכיבים. יש לקרוא את הנספח במלואו לפני התקנת או הגדרת הרכיבים במארזי סופרמיקרו.

اَكْ ف حالة وُكِي اَي تتسبب ف اصابة جسدهُ هذا الزهز عُ خطر! تحذُرُ .
 قبل اَي تعول على اَي هعدات، كي على علن بالوخاطز ال اُجوة عي الذوائر
 الكهزبائِة
 وكي على دراةُ بالووارسات النقااِة لو عُ وقع اَي حادث
 استخدم رقن الب اِى الو صُص ف هاةُ كل تحذُرُ للعشر تزجوتها

안전을 위한 주의사항

경고!

이 경고 기호는 위험이 있음을 알려 줍니다. 작업자의 신체에 부상을 야기 할 수 있는 상태에 있게 됩니다. 모든 장비에 대한 작업을 수행하기 전에 전기회로와 관련된 위험요소들을 확인하시고 사전에 사고를 방지할 수 있도록 표준 작업절차를 준수해 주시기 바랍니다.

해당 번역문을 찾기 위해 각 경고의 마지막 부분에 제공된 경고문 번호를 참조하십시오

BELANGRIJKE VEILIGHEIDSINSTRUCTIES

Dit waarschuwings symbool betekent gevaar. U verkeert in een situatie die lichamelijk letsel kan veroorzaken. Voordat u aan enige apparatuur gaat werken, dient u zich bewust te zijn van de bij een elektrische installatie betrokken risico's en dient u op de hoogte te zijn van de standaard procedures om ongelukken te voorkomen. Gebruik de nummers aan het eind van elke waarschuwing om deze te herleiden naar de desbetreffende locatie.

BEWAAR DEZE INSTRUCTIES

Installation Instructions



Warning! Read the installation instructions before connecting the system to the power source.

設置手順書

システムを電源に接続する前に、設置手順書をお読み下さい。

警告

将此系统连接电源前,请先阅读安装说明。

警告

將系統與電源連接前，請先閱讀安裝說明。

Warnung

Vor dem Anschließen des Systems an die Stromquelle die Installationsanweisungen lesen.

¡Advertencia!

Lea las instrucciones de instalación antes de conectar el sistema a la red de alimentación.

Attention

Avant de brancher le système sur la source d'alimentation, consulter les directives d'installation.

יש לקרוא את הוראות התקנה לפני חיבור המערכת למקור מתח.

اقر إرشادات التركيب قبل توصيل النظام إلى مصدر للطاقة

시스템을 전원에 연결하기 전에 설치 안내를 읽어주십시오.

Waarschuwing

Raadpleeg de installatie-instructies voordat u het systeem op de voedingsbron aansluit.

Circuit Breaker

Warning! This product relies on the building's installation for short-circuit (overcurrent) protection. Ensure that the protective device is rated not greater than: 250 V, 20 A.

サーキット・ブレーカー

この製品は、短絡(過電流)保護装置がある建物での設置を前提としています。

保護装置の定格が250 V、20 Aを超えないことを確認下さい。

警告

此产品的短路(过载电流)保护由建筑物的供电系统提供,确保短路保护设备的额定电流不大于250V,20A。

警告

此產品的短路(過載電流)保護由建築物的供電系統提供,確保短路保護設備的額定電流不大於250V,20A。

Warnung

Dieses Produkt ist darauf angewiesen, dass im Gebäude ein Kurzschluss- bzw. Überstromschutz installiert ist. Stellen Sie sicher, dass der Nennwert der Schutzvorrichtung nicht mehr als: 250 V, 20 A beträgt.

¡Advertencia!

Este equipo utiliza el sistema de protección contra cortocircuitos (o sobrecorrientes) del edificio. Asegúrese de que el dispositivo de protección no sea superior a: 250 V, 20 A.

Attention

Pour ce qui est de la protection contre les courts-circuits (surtension), ce produit dépend de l'installation électrique du local. Vérifiez que le courant nominal du dispositif de protection n'est pas supérieur à :250 V, 20 A.

מוצר זה מסתמך על הגנה המותקנת במבנים למניעת קצר חשמלי. יש לוודא כי המכשיר המגן מפני הקצר החשמלי הוא לא יותר מ-250VDC, 20A

هذا المنتج يعتمد على معدات الحماية من الدوائر القصيرة التي تم تثبيتها في المبنى
تأكد من أن تقييم الجهاز الوقائي ليس أكثر من : 20A, 250V

경고!

이 제품은 전원의 단락(과전류)방지에 대해서 전적으로 건물의 관련 설비에 의존합니다. 보호장치의 정격이 반드시 250V(볼트), 20A(암페어)를 초과하지 않도록 해야 합니다.

Waarschuwing

Dit product is afhankelijk van de kortsluitbeveiliging (overspanning) van uw elektrische installatie. Controleer of het beveiligde apparaat niet groter gedimensioneerd is dan 250V, 20A.

Power Disconnection Warning



Warning! The system must be disconnected from all sources of power and the power cord removed from the power supply module(s) before accessing the chassis interior to install or remove system components.



電源切断の警告

システムコンポーネントの取り付けまたは取り外しのために、シャーシ内部にアクセスするには、システムの電源はすべてのソースから切断され、電源コードは電源モジュールから取り外す必要があります。

警告

在你打开机箱并安装或移除内部器件前,必须将系统完全断电,并移除电源线。

警告

在您打開機殼安裝或移除內部元件前，必須將系統完全斷電，並移除電源線。

Warnung

Das System muss von allen Quellen der Energie und vom Netzanschlusskabel getrennt sein, das von den Spg.Versorgungsteilmodulen entfernt wird, bevor es auf den Chassisinnenraum zurückgreift, um Systemsbestandteile anzubringen oder zu entfernen.

¡Advertencia!

El sistema debe ser disconnected de todas las fuentes de energía y del cable eléctrico quitado de los módulos de fuente de alimentación antes de tener acceso el interior del chasis para instalar o para quitar componentes de sistema.

Attention

Le système doit être débranché de toutes les sources de puissance ainsi que de son cordon d'alimentation secteur avant d'accéder à l'intérieur du chasis pour installer ou enlever des composants de système.

אזהרה מפני ניתוק חשמלי

אזהרה!

יש לנתק את המערכת מכל מקורות החשמל ויש להסיר את כבל החשמלי מהספק לפני גישה לחלק הפנימי של המארז לצורך התקנת או הסרת רכיבים.

يجب فصل انظاؤ من جميع مصادر انطاقت وإزانت سهك انكهرباء من وحدة امداد انطاقت قېم

انصل إلى امناطق انداخييت نههيكم نثبيج أو إزانت مكناث الجهاز

경고!

시스템에 부품들을 장착하거나 제거하기 위해서는 새시 내부에 접근하기 전에 반드시 전원 공급장치로부터 연결되어있는 모든 전원과 전기코드를 분리해주어야 합니다.

Waarschuwing

Voordat u toegang neemt tot het binnenwerk van de behuizing voor het installeren of verwijderen van systeem onderdelen, dient u alle spanningsbronnen en alle stroomkabels aangesloten op de voeding(en) van de behuizing te verwijderen

Equipment Installation



Warning! Only trained and qualified personnel should be allowed to install, replace, or service this equipment.

機器の設置

トレーニングを受け認定された人だけがこの装置の設置、交換、またはサービスを許可されていません。

警告

只有经过培训且具有资格的人员才能进行此设备的安装、更换和维修。

警告

只有經過受訓且具資格人員才可安裝、更換與維修此設備。

Warnung

Das Installieren, Ersetzen oder Bedienen dieser Ausrüstung sollte nur geschultem, qualifiziertem Personal gestattet werden.

¡Advertencia!

Solamente el personal calificado debe instalar, reemplazar o utilizar este equipo.

Attention

Il est vivement recommandé de confier l'installation, le remplacement et la maintenance de ces équipements à des personnels qualifiés et expérimentés.

אזהרה!

צוות מוסמך בלבד רשאי להתקין, להחליף את הציוד או לתת שירות עבור הציוד.

والمدربيه لتزكيب واستبدال أو خدمة هذا الجهاز يجب أن يسمح فقط للمظفيه المؤهليه

경고!

훈련을 받고 공인된 기술자만이 이 장비의 설치, 교체 또는 서비스를 수행할 수 있습니다.

Waarschuwing

Deze apparatuur mag alleen worden geïnstalleerd, vervangen of hersteld door geschoold en gekwalificeerd personeel.

Restricted Area

Warning! This unit is intended for installation in restricted access areas. A restricted access area can be accessed only through the use of a special tool, lock and key, or other means of security. (This warning does not apply to workstations).

アクセス制限区域

このユニットは、アクセス制限区域に設置されることを想定しています。

アクセス制限区域は、特別なツール、鍵と錠前、その他のセキュリティの手段を用いてのみ出入りが可能です。

警告

此部件应安装在限制进出的场所，限制进出的场所指只能通过使用特殊工具、锁和钥匙或其它安全手段进出的场所。

警告

此装置仅限安装於進出管制區域，進出管制區域係指僅能以特殊工具、鎖頭及鑰匙或其他安全方式才能進入的區域。

Warnung

Diese Einheit ist zur Installation in Bereichen mit beschränktem Zutritt vorgesehen. Der Zutritt zu derartigen Bereichen ist nur mit einem Spezialwerkzeug, Schloss und Schlüssel oder einer sonstigen Sicherheitsvorkehrung möglich.

¡Advertencia!

Esta unidad ha sido diseñada para instalación en áreas de acceso restringido. Sólo puede obtenerse acceso a una de estas áreas mediante la utilización de una herramienta especial, cerradura con llave u otro medio de seguridad.

Attention

Cet appareil doit être installée dans des zones d'accès réservés. L'accès à une zone d'accès réservé n'est possible qu'en utilisant un outil spécial, un mécanisme de verrouillage et une clé, ou tout autre moyen de sécurité.

אזור עם גישה מוגבלת

אזהרה!

יש להתקין את היחידה באזורים שיש בהם הגבלת גישה. הגישה ניתנת בעזרת 'כלי אבטחה בלבד' (מפתח, מנעול וכד.).

تخصيص هذه انحدة نترك بُها ف مناطق محظورة تم .

،ممكن اننصل إن منطقت محظورة فقط من خلال استخذاو أداة خاصت أو أ وس هُت أخري نلالأمما ققم ومفتاح

경고!

이 장치는 접근이 제한된 구역에 설치하도록 되어있습니다. 특수도구, 잠금 장치 및 키, 또는 기타 보안 수단을 통해서만 접근 제한 구역에 들어갈 수 있습니다.

Waarschuwing

Dit apparaat is bedoeld voor installatie in gebieden met een beperkte toegang. Toegang tot dergelijke gebieden kunnen alleen verkregen worden door gebruik te maken van speciaal gereedschap, slot en sleutel of andere veiligheidsmaatregelen.

Battery Handling



Warning! There is the danger of explosion if the battery is replaced incorrectly. Replace the battery only with the same or equivalent type recommended by the manufacturer. Dispose of used batteries according to the manufacturer's instructions

電池の取り扱い

電池交換が正しく行われなかった場合、破裂の危険性があります。交換する電池はメーカーが推奨する型、または同等のものを使用下さい。使用済電池は製造元の指示に従って処分して下さい。

警告

電池更換不當會有爆炸危險。請只使用同類電池或制造商推荐的功能相当的電池更換原有電池。請按制造商的說明處理廢舊電池。

警告

電池更換不當會有爆炸危險。請使用製造商建議之相同或功能相當的電池更換原有電池。請按照製造商的說明指示處理廢棄舊電池。

Warnung

Bei Einsetzen einer falschen Batterie besteht Explosionsgefahr. Ersetzen Sie die Batterie nur durch den gleichen oder vom Hersteller empfohlenen Batterietyp. Entsorgen Sie die benutzten Batterien nach den Anweisungen des Herstellers.

Attention

Danger d'explosion si la pile n'est pas remplacée correctement. Ne la remplacer que par une pile de type semblable ou équivalent, recommandée par le fabricant. Jeter les piles usagées conformément aux instructions du fabricant.

¡Advertencia!

Existe peligro de explosión si la batería se reemplaza de manera incorrecta. Reemplazar la batería exclusivamente con el mismo tipo o el equivalente recomendado por el fabricante. Desechar las baterías gastadas según las instrucciones del fabricante.

אזהרה!

קיימת סכנת פיצוץ של הסוללה במידה והוחלפה בדרך לא תקינה. יש להחליף את הסוללה בסוג התואם מחברת יצרן מומלצת. סילוק הסוללות המשומשות יש לבצע לפי הוראות היצרן.

هناك خطر من انفجار في حالة اسبدال البطارية بطريقة غير صحيحة فعلياً
اسبدال البطارية
فقط بنفس النوع أو ما يعادلها مما أوصت به الشركة المصنعة
جخلص من البطاريات المسحومة وفقاً لعمليات الشركة الصانعة

경고!

배터리가 올바르게 교체되지 않으면 폭발의 위험이 있습니다. 기존 배터리와 동일하거나 제조사에서 권장하는 동등한 종류의 배터리로만 교체해야 합니다. 제조사의 안내에 따라 사용된 배터리를 처리하여 주십시오.

Waarschuwing

Er is ontploffingsgevaar indien de batterij verkeerd vervangen wordt. Vervang de batterij slechts met hetzelfde of een equivalent type die door de fabrikant aanbevolen wordt. Gebruikte batterijen dienen overeenkomstig fabrieksvoorschriften afgevoerd te worden.

Redundant Power Supplies



Warning! This unit might have more than one power supply connection. All connections must be removed to de-energize the unit.

冗長電源装置

このユニットは複数の電源装置が接続されている場合があります。

ユニットの電源を切るためには、すべての接続を取り外さなければなりません。

警告

此部件连接的电源可能不止一个，必须将所有电源断开才能停止给该部件供电。

警告

此装置连接的电源可能不只一个，必须切断所有电源才能停止对该装置的供电。

Warnung

Dieses Gerät kann mehr als eine Stromzufuhr haben. Um sicherzustellen, dass der Einheit kein Strom zugeführt wird, müssen alle Verbindungen entfernt werden.

¡Advertencia!

Puede que esta unidad tenga más de una conexión para fuentes de alimentación. Para cortar por completo el suministro de energía, deben desconectarse todas las conexiones.

Attention

Cette unité peut avoir plus d'une connexion d'alimentation. Pour supprimer toute tension et tout courant électrique de l'unité, toutes les connexions d'alimentation doivent être débranchées.

אם קיים יותר מספק אחד

אזהרה!

ליחידה יש יותר מחיבור אחד של ספק. יש להסיר את כל החיבורים על מנת לרוקן את היחידה.

قد يكون لهذا الجهاز عدة اتصالات بوحدات امداد الطاقة .

يجب إزالة كافة الاتصالات لعسل الوحدة عن الكهرباء

경고!

이 장치에는 한 개 이상의 전원 공급 단자가 연결되어 있을 수 있습니다. 이 장치에 전원을 차단하기 위해서는 모든 연결 단자를 제거해야만 합니다.

Waarschuwing

Deze eenheid kan meer dan één stroomtoevoeraansluiting bevatten. Alle aansluitingen dienen verwijderd te worden om het apparaat stroomloos te maken.

Backplane Voltage



Warning! Hazardous voltage or energy is present on the backplane when the system is operating. Use caution when servicing.

バックプレーンの電圧

システムの稼働中は危険な電圧または電力が、バックプレーン上にかかっています。

修理する際には注意ください。

警告

当系统正在进行时，背板上有很危险的电压或能量，进行维修时务必小心。

警告

當系統正在進行時，背板上有危險的電壓或能量，進行維修時務必小心。

Warnung

Wenn das System in Betrieb ist, treten auf der Rückwandplatine gefährliche Spannungen oder Energien auf. Vorsicht bei der Wartung.

¡Advertencia!

Cuando el sistema está en funcionamiento, el voltaje del plano trasero es peligroso. Tenga cuidado cuando lo revise.

Attention

Lorsque le système est en fonctionnement, des tensions électriques circulent sur le fond de panier. Prendre des précautions lors de la maintenance.

מתח בפנל האחורי

אזהרה!

קיימת סכנת מתח בפנל האחורי בזמן תפעול המערכת. יש להיזהר במהלך העבודה.

هناك خطر من التيار الكهربائي أو الطاقة المتجددة على اللوحة
عندما يكون النظام يعمل كه حذرا عند خدمة هذا الجهاز

경고!

시스템이 동작 중일 때 후면판 (Backplane)에는 위험한 전압이나 에너지가 발생 합니다.
서비스 작업 시 주의하십시오.

Waarschuwing

Een gevaarlijke spanning of energie is aanwezig op de backplane wanneer het systeem in gebruik is. Voorzichtigheid is geboden tijdens het onderhoud.

Comply with Local and National Electrical Codes



Warning! Installation of the equipment must comply with local and national electrical codes.

地方および国の電気規格に準拠

機器の取り付けはその地方および国の電気規格に準拠する必要があります。

警告

设备安装必须符合本地与本国电气法规。

警告

設備安裝必須符合本地與本國電氣法規。

Warnung

Die Installation der Geräte muss den Sicherheitsstandards entsprechen.

¡Advertencia!

La instalación del equipo debe cumplir con las normas de electricidad locales y nacionales.

Attention

L'équipement doit être installé conformément aux normes électriques nationales et locales.

תיאום חוקי החשמל הארצי
אזהרה!
התקנת הציוד חייבת להיות תואמת לחוקי החשמל המקומיים והארציים.

تركيب المعدات الكهربائية يجب أن يمتثل للقوايه المحلية والبطية المتعلقة
بالكهرباء

경고!

현 지역 및 국가의 전기 규정에 따라 장비를 설치해야 합니다.

Waarschuwing

Bij installatie van de apparatuur moet worden voldaan aan de lokale en nationale elektriciteitsvoorschriften.

Product Disposal



Warning! Ultimate disposal of this product should be handled according to all national laws and regulations.

製品の廃棄

この製品を廃棄処分する場合、国の関係する全ての法律・条例に従い処理する必要があります。

警告

本产品的废弃处理应根据所有国家的法律和规章进行。

警告

本產品的廢棄處理應根據所有國家的法律和規章進行。

Warnung

Die Entsorgung dieses Produkts sollte gemäß allen Bestimmungen und Gesetzen des Landes erfolgen.

¡Advertencia!

Al deshacerse por completo de este producto debe seguir todas las leyes y reglamentos nacionales.

Attention

La mise au rebut ou le recyclage de ce produit sont généralement soumis à des lois et/ou directives de respect de l'environnement. Renseignez-vous auprès de l'organisme compétent.

סילוק המוצר

אזהרה!

סילוק סופי של מוצר זה חייב להיות בהתאם להנחיות וחוקי המדינה.

التخلص النهائي من هذا المنتج ينبغي التعامل معه وفقا لجميع القوانين واللوائح الوطنية عند

경고!

이 제품은 해당 국가의 관련 법규 및 규정에 따라 폐기되어야 합니다.

Waarschuwing

De uiteindelijke verwijdering van dit product dient te geschieden in overeenstemming met alle nationale wetten en reglementen.

Hot Swap Fan Warning



Warning! Hazardous moving parts. Keep away from moving fan blades. The fans might still be turning when you remove the fan assembly from the chassis. Keep fingers, screwdrivers, and other objects away from the openings in the fan assembly's housing.

ファン・ホットスワップの警告

警告!回転部品に注意。運転中は回転部(羽根)に触れないでください。シャーシから冷却ファン装置を取り外した際、ファンがまだ回転している可能性があります。ファンの開口部に、指、ドライバー、およびその他のものを近づけないで下さい。

警告!

警告! 危險的可移動性零件。請務必與轉動的风扇叶片保持距離。當您從機架移除風扇裝置，風扇可能仍在轉動。小心不要將手指、螺絲起子和其他物品太靠近風扇

警告

危險的可移動性零件。請務必與轉動的风扇叶片保持距離。當您從機架移除風扇裝置，風扇可能仍在轉動。小心不要將手指、螺絲起子和其他物品太靠近風扇。

Warnung

Gefährlich Bewegende Teile. Von den bewegenden Lüfterblätter fern halten. Die Lüfter drehen sich u. U. noch, wenn die Lüfterbaugruppe aus dem Chassis genommen wird. Halten Sie Finger, Schraubendreher und andere Gegenstände von den Öffnungen des Lüftergehäuses entfernt.

¡Advertencia!

Riesgo de piezas móviles. Mantener alejado de las aspas del ventilador. Los ventiladores podran dar vuelta cuando usted quite el montaje del ventilador del chasis. Mantenga los dedos, los destornilladores y todos los objetos lejos de las aberturas del ventilador

Attention

Pieces mobiles dangereuses. Se tenir a l'écart des lames du ventilateur Il est possible que les ventilateurs soient toujours en rotation lorsque vous retirerez le bloc ventilateur du châssis. Prenez garde à ce que doigts, tournevis et autres objets soient éloignés du logement du bloc ventilateur.

אזהרה!

חלקים נעים מסוכנים. התרחק מלהבי המאוורר בפעולה כאשר מסירים את חלקי המאוורר מהמארז, יתכן והמאווררים עדיין עובדים. יש להרחיק למרחק בטוח את האצבעות וכלי עבודה שונים מהפתחים בתוך המאוורר

تحذير! أجزاء متحركة خطيرة. ابتعد عن شفرات المروحة المتحركة. من الممكن أن المراوح لا تزال تدور عند إزالة كتلة المروحة من الهيكل يجب إبقاء الأصابع ومفكات البراغي وغيرها من الأشياء بعيدا عن الفتحات في كتلة المروحة

경고!

움직이는 위험한 부품. 회전하는 송풍 날개에 접근하지 마세요. 새시로부터 팬 조립품을 제거할 때 팬은 여전히 회전하고 있을 수 있습니다. 팬 조립품 외관의 열려있는 부분들로부터 손가락 및 스크류드라이버, 다른 물체들이 가까이 하지 않도록 배치해 주십시오.

Waarschuwing

Gevaarlijk bewegende onderdelen. Houd voldoende afstand tot de bewegende ventilatorbladen. Het is mogelijk dat de ventilator nog draait tijdens het verwijderen van het ventilatorsamenstel uit het chassis. Houd uw vingers, schroevendraaiers en eventuele andere voorwerpen uit de buurt van de openingen in de ventilatorbehuizing.

Power Cable and AC Adapter



Warning! When installing the product, use the provided or designated connection cables, power cables and AC adaptors. Using any other cables and adaptors could cause a malfunction or a fire. Electrical Appliance and Material Safety Law prohibits the use of UL or CSA -certified cables (that have UL/CSA shown on the cord) for any other electrical devices than products designated by Supermicro only.

電源コードとACアダプター

製品を設置する場合、提供または指定および購入された接続ケーブル、電源コードとACアダプターを該当する地域の条例や安全基準に適合するコードサイズやプラグと共に使用下さい。他のケーブルやアダプタを使用すると故障や火災の原因になることがあります。

電気用品安全法は、ULまたはCSA認定のケーブル(UL/CSAマークがコードに表記)を Supermicro が指定する製品以外に使用することを禁止しています。

警告

安装此产品时,请使用本身提供的或指定的或采购的连接线,电源线和电源适配器。包含遵照当地法规和安全要求的合规的电源线尺寸和插头。使用其它线材或适配器可能会引起故障或火灾。除了Supermicro所指定的产品,电气用品和材料安全法律规定禁止使用未经UL或CSA认证的线材。(线材上会显示UL/CSA符号)。

警告

安裝此產品時,請使用本身提供的或指定的或採購的連接線,電源線和電源適配器。包含遵照當地法規和安全要求的合規的電源線尺寸和插頭。使用其它線材或適配器可能會引起故障或火災。除了Supermicro所指定的產品,電氣用品和材料安全法律規定禁止使用未經UL或CSA認證的線材。(線材上會顯示UL/CSA符號)。

Warnung

Nutzen Sie beim Installieren des Produkts ausschließlich die von uns zur Verfügung gestellten Verbindungskabeln, Stromkabeln und/oder Adapter, die Ihre örtlichen Sicherheitsstandards einhalten. Der Gebrauch von anderen Kabeln und Adapter können Fehlfunktionen oder Feuer verursachen. Die Richtlinien untersagen das Nutzen von UL oder CAS zertifizierten Kabeln (mit UL/CSA gekennzeichnet), an Geräten oder Produkten die nicht mit Supermicro gekennzeichnet sind.

¡Advertencia!

Cuando instale el producto, utilice la conexión provista o designada o procure cables, Cables de alimentación y adaptadores de CA que cumplan con los códigos locales y los requisitos de seguridad, incluyendo el tamaño adecuado del cable y el enchufe. El uso de otros cables y adaptadores podría causar un mal funcionamiento o un incendio. La Ley de Seguridad de Aparatos Eléctricos y de Materiales prohíbe El uso de cables certificados por UL o CSA (que tienen el certificado UL / CSA en el código) para cualquier otros dispositivos eléctricos que los productos designados únicamente por Supermicro.

Attention

Lors de l'installation du produit, utilisez les cables de connection fournis ou désigné ou achetez des cables, cables de puissance et adaptateurs respectant les normes locales et les conditions de securite y compris les tailles de cables et les prises electriques appropries. L'utilisation d'autres cables et adaptateurs peut provoquer un dysfonctionnement ou un incendie. Appareils électroménagers et la Loi sur la Sécurité Matériel interdit l'utilisation de câbles certifiés- UL ou CSA (qui ont UL ou CSA indiqué sur le code) pour tous les autres appareils électriques sauf les produits désignés par Supermicro seulement.

AC ימאתמו מיילמשח מילבכ

!הרהזא

ךרוצל ומאתוה וא ושכרנ רשא AC מימאתמו מיקפס, מילבכב שמתשהל שי, רצומה תא מיניקתמ רשאכ לכב שומיש . עקתהו לבכה לש הנוכח הדימ ללוכ, תוימוקמה תוחיטבה תושירדל ומאתוה רשאו, הנקתהה למשחה ירישכמב שומישה יקוחל מאתהב. ילמשח רצק וא הלקתל מורגל לולע, רחא גוסמ מאתמ וא לבכ לש דוק מהילע עיפומ רשאכ) UL-ב או CSA-ב -ב מיכמסומה מילבכב שמתשהל רוסיא מייק, תוחיטבה יקוחו דבלב Supermicro י"ע מאתוה רשא רצומב קר אלא, רחא ילמשח רצומ לכ רובע (UL/CSA)

תאלבאלא אארשב מץ וא אדדחמלא וא ארפוטמלא תאליטוטלא מאדחטסאב מץ, אגתנמלא בייקרת דנע לכלז יפ אמב אילחמלא אלאסלא תאבלטתמו נינאוץב מאזתלאלא אמ דדרתמלא ראיטלא תאלוחמו אילברמלא קיירח וא לטע יפ בבסטטי דץ ירשא תאלוחמו תאלבאלא יא מאדחטסא. מילסלא סבאלאו לטומוא מץ ח CSA וא UL לביק נמ אדמתעמלא תאלבאלא מאדחטסא תאדעמלא אילברמלא אזהאלל אלאסלא נונאק רזחי Supermicro לביק נמ אדדחמלא אילברמלא תאגתנמלא רייג ירשא תאדעמ יא אמ (UL/CSA) אלאסלא למחתיטלאו

전원 케이블 및 AC 어댑터

경고! 제품을 설치할 때 현지 코드 및 적절한 굵기의 코드와 플러그를 포함한 안전 요구 사항을 준수하여 제공되거나 지정된 연결 혹은 구매 케이블, 전원 케이블 및 AC 어댑터를 사용하십시오.

다른 케이블이나 어댑터를 사용하면 오작동이나 화재가 발생할 수 있습니다. 전기 용품 안전법은 UL 또는 CSA 인증 케이블 (코드에 UL / CSA가 표시된 케이블)을 Supermicro 가 지정한 제품 이외의 전기 장치에 사용하는 것을 금지합니다.

Stroomkabel en AC-Adapter

Waarschuwing! Bij het aansluiten van het Product uitsluitend gebruik maken van de geleverde Kabels of een andere geschikte aan te schaffen Aansluitmethode, deze moet altijd voldoen aan de lokale voorschriften en veiligheidsnormen, inclusief de juiste kabeldikte en stekker. Het gebruik van niet geschikte Kabels en/of Adapters kan een storing of brand veroorzaken. Wetgeving voor Elektrische apparatuur en Materiaalveiligheid verbied het gebruik van UL of CSA -gecertificeerde Kabels (met UL/CSA in de code) voor elke andere toepassing dan de door Supermicro hiervoor beoogde Producten.

Appendix B

System Specifications

Processor

A2SAN-LN4-E: Intel® Atom™ x5-E3940 Processor, Quad Core, 2M Cache, 1.6GHz-1.8GHz, TDP 9.5W

A2SAN-LN4-C: Intel® Celeron® J3455 Processor, Quad Core, 2M Cache, 1.5GHz-2.3GHz, TDP 10W

Note: Refer to the motherboard specifications pages on our website for updates to supported processors.

Chipset

System on Chip (SoC)

BIOS

AMI/1 BIOS Chip

Memory

Integrated memory controller supports up to 8GB DDR3L 1866MHz Non-ECC SO-DIMM

Storage Drives

One SATA 3.0 for 2.5" 7mm SATA HDD/SSD

PCI Expansion Slots

One Full size Mini-PCIe (1 USB 2.0, 1 PCIe Gen2)

Three M.2 B-Key (USB) 2242/3042 with Nano SIM Slots

One M.2 E-Key 2230

Input/Output

LAN: Four Gigabit Ethernet ports

USB: Two USB3.0 ports (rear)

Display: One HDMI port

One COM port

Motherboard

A2SAN-LN4-E/-C; 5.866" (W) x 4.17" (L) (149 mm x 106 mm)

Chassis

CSE-E102TF; 3.5" SBC Rackmount, 7.48 x 1.72 x 4.72 in. (190 x 44 x 120 mm) (WxDxH)

System Cooling

One 4-cm PWM system fan (optional)

Power Supply

Model: MCP-250-10134-0N (60W)

AC Input

100-127 Vac, 50-60 Hz

200-240 Vac, 50-60 Hz

+12 V: 29 A

+12 V standby: Max: 3 A, Min: 0 A

+ 5 V: 15 A

+3.3 V: 12 A

Operating Environment

Operating Temperature: 0° to 40° C (32° to 104° F)

Non-operating Temperature: -40° to 70° C (-40° to 158° F)

Operating Relative Humidity: 8% to 90% (non-condensing)

Non-operating Relative Humidity: 5% to 95% (non-condensing)

Regulatory Compliance

FCC, ICES, CE, UKCA, VCCI, RCM, NRTL, CB

Applied Directives, Standards

EMC/EMI: 2014/30/EU (EMC Directive)

Electromagnetic Compatibility Regulations 2016

FCC Part 15 Subpart B

ICES-003

VCCI-CISPR 32

AS/NZS CISPR 32

BS/EN55032

BS/EN55035

CISPR 32

CISPR 35

BS/EN 61000-3-2

BS/EN 61000-3-3

BS/EN 61000-4-2

BS/EN 61000-4-3

BS/EN 61000-4-4

BS/EN 61000-4-5

BS/EN 61000-4-6

BS/EN 61000-4-8

BS/EN 61000-4-11

Environment:

2011/65/EU (RoHS Directive)

EC 1907/2006 (REACH)

2012/19/EU (WEEE Directive)

California Proposition 65

Product Safety: 2014/35/EU (LVD Directive)

UL/CSA 62368-1 (USA and Canada)

Electrical Equipment (Safety) Regulations 2016

IEC/BS/EN 62368-1

Perchlorate Warning

California Best Management Practices Regulations for Perchlorate Materials: This Perchlorate warning applies only to products containing CR (Manganese Dioxide) Lithium coin cells. "Perchlorate Material-special handling may apply. See www.dtsc.ca.gov/hazardouswaste/perchlorate"

この装置は、クラスA機器です。この装置を住宅環境で使用すると電波妨害を引き起こすことがあります。この場合には使用者が適切な対策を講ずるよう要求されることがあります。

VCCI – A