

SuperWorkstaion 7033A-T Serverboard Components

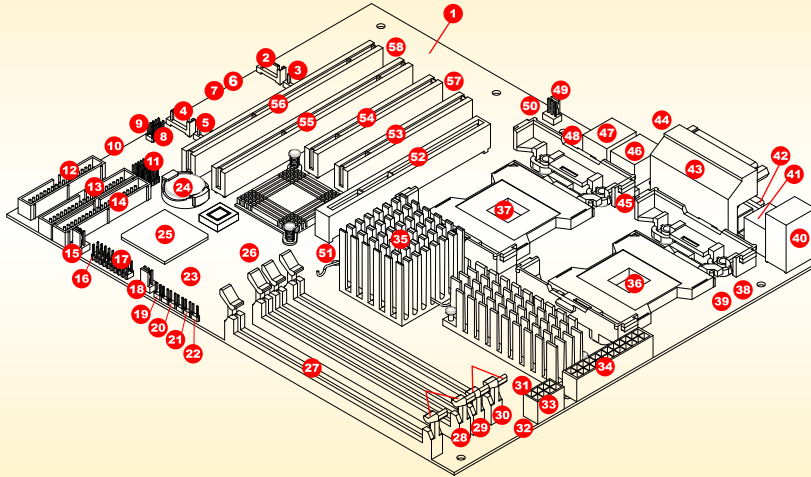

1 Super X5DAL-TG2 serverboard	20 JP36: Power supply fail alarm reset switch	39 JPWAKE: Keyboard wake-up
2 Serial ATA port #4	21 JOH1: Overheat LED	40 Keyboard & mouse
3 Serial ATA port #3	22 JP37: Watch dog	41 USB 0/1 port
4 Serial ATA port #2	23 JWOR1: Wake-on-Ring header	42 COM1 port
5 Serial ATA port #1	24 Battery	43 Parallel port
6 JPA1: SATA #1/#2 Enable/Disable	25 ICH4 chipset	44 COM2 port
7 JPA2: SATA #3/#4 Enable/Disable	26 JP39: System bus speed	45 CPU fan1
8 JL1: Chassis intrusion header	27 DIMM #4 socket	46, 47 Gigabit LAN 1/2 ports
9 JSLED: SATA LED header	28 DIMM #3 socket	48 CPU fan2
10 WOL1: Wake-on-LAN header	29 DIMM #2 socket	49 Overheat fan
11 FPUSB 0/1/2/3: Front panel USB headers	30 DIMM #1 socket	50 JP38: Thermal fan control
12 Floppy connector	31 JP9: Power fail alarm En/Disable	51 J30: Power conn.(for use w/AGP Pro cards)
13 IDE#2 connector	32 JP8: Third power supply fail header	52 8xAGP 1.5V
14 IDE#1 connector	33 J15: CPU power connector	53 PCI #2/33MHz
15 Chassis fan2	34 ATX power connector	54 PCI #1/33MHz
16 JBT1: CMOS clear	35 MCH	55 PCI-X #2/100MHz
17 JF2: Front control panel connector	36 CPU1 socket	56 PCI-X #1/66MHz
18 Chassis fan1	37 CPU2 socket	57 J12: IR/CIR header
19 JD1: PWR LED/speaker header	38 JPUSB: USB wake-up	58 JPL1: Gigabit Enable/Disable

Note: Interleaved ECC registered memory requires DDR DIMMs to be installed in pair.

Front Panel Functions

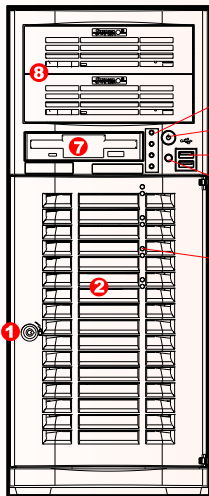

1. Front bezel lock
2. 4 x 1" hot-swap SATA drive bays
3. SATA activity LED
4. Reset: use the reset button to reboot the system
5. Front side USB access
6. Main power button
7. Floppy drive
8. 2 x 5.25" drive bays
9. Power: Indicates power is being supplied to the system.
10. HDD: Indicates IDE hard disk/CD-ROM drive activity.
11. NIC: Indicates network activity on GLAN port.
12. Overheat: Indicates an overheat condition in either one of the processors.

Rear Panel Functions

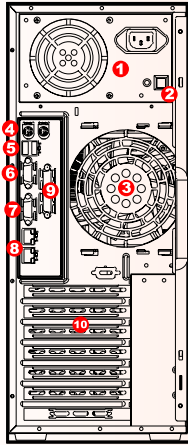

1. Power supply
2. Alarm reset button
3. 12cm exhaust fan
4. Mouse & keyboard ports
5. USB ports
6. COM1 port
7. COM2 port
8. Ethernet ports
9. Parallel port
10. PCI expansion slots

X5DAL-TG2 Quick Reference

Jumpers	Description	Default Setting
JBT1	CMOS Clear	Pad
JP9	Power Fail Alarm En/Disable	Open (Disabled)
JP37	Watch Dog	Pins 2-3 (NMI)
JP38	Thermal Fan Control	Closed (Full Speed)
JP39	System Bus Speed	Pins 1-2 (Auto)
JPA1	SATA #1/#2 Enable/Disable	Pins 1-2 (Enabled)
JPA2	SATA #3/#4 Enable/Disable	Pins 1-2 (Enabled)
JPL1	GLAN Enable/Disable	Pins 1-2 (Enabled)
JPUSB	USB Wake-up	Pins 1-2 (Disabled)
JPWAKE	Keyboard Wake-up	Pins 1-2 (Disabled)

Cooling Fan Installation

Warning !

CPU Heatsink Installation Procedures (For Supermicro SuperWorkstation System)

Due to the fact that adequate air flow and proper thermal control are very critical in maintaining system's stability and performance, it is imperative that the proper installation procedures listed below be followed in order to maximize system performance. This is especially critical for SuperWorkstation dual Xeon processor server solutions.

- 1) Only those CPU heatsinks that are provided by Supermicro should be used.
- 2) Apply a small amount of silicon compound on the CPU's die.
- 3) Place the CPU heatsink on top of the CPU.
- 4) Attach the heatsink clips to the heatsink retention pieces, one on each side of the heatsink as shown in the diagram at right.
- 5) The three tabs on each heatsink retention pieces should completely protrude through the corresponding holes on the heatsink clips.

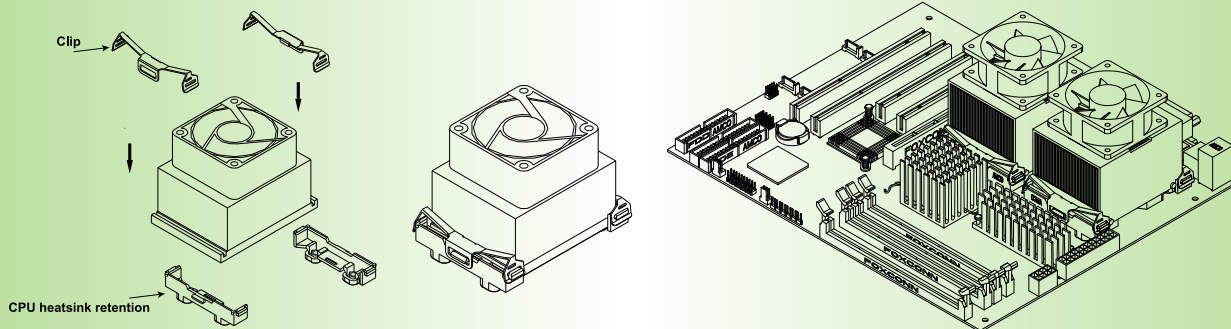

© 2003 Super Micro Computer Inc. Specifications subject to change without notice. All other brands and names are the property of their respective owners.

SUPERMICRO[®]
www.supermicro.com

To protect the system and components, it is essential that you reinstall the top panel after you have finished working on the system.