

SUPERO[®]

SUPERWORKSTATION 7034A-T
SUPERWORKSTATION 7034A-i

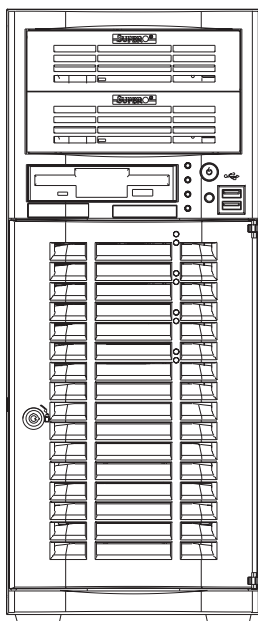

USER'S MANUAL

The information in this User's Manual has been carefully reviewed and is believed to be accurate. The vendor assumes no responsibility for any inaccuracies that may be contained in this document, makes no commitment to update or to keep current the information in this manual, or to notify any person or organization of the updates. **Please Note: For the most up-to-date version of this manual, please see our web site at www.supermicro.com.**

SUPERMICRO COMPUTER reserves the right to make changes to the product described in this manual at any time and without notice. This product, including software, if any, and documentation may not, in whole or in part, be copied, photocopied, reproduced, translated or reduced to any medium or machine without prior written consent.

IN NO EVENT WILL SUPERMICRO COMPUTER BE LIABLE FOR DIRECT, INDIRECT, SPECIAL, INCIDENTAL, SPECULATIVE OR CONSEQUENTIAL DAMAGES ARISING FROM THE USE OR INABILITY TO USE THIS PRODUCT OR DOCUMENTATION, EVEN IF ADVISED OF THE POSSIBILITY OF SUCH DAMAGES. IN PARTICULAR, THE VENDOR SHALL NOT HAVE LIABILITY FOR ANY HARDWARE, SOFTWARE, OR DATA STORED OR USED WITH THE PRODUCT, INCLUDING THE COSTS OF REPAIRING, REPLACING, INTEGRATING, INSTALLING OR RECOVERING SUCH HARDWARE, SOFTWARE, OR DATA.

Any disputes arising between manufacturer and customer shall be governed by the laws of Santa Clara County in the State of California, USA. The State of California, County of Santa Clara shall be the exclusive venue for the resolution of any such disputes. Supermicro's total liability for all claims will not exceed the price paid for the hardware product.

Unless you request and receive written permission from SUPER MICRO COMPUTER, you may not copy any part of this document.

Information in this document is subject to change without notice. Other products and companies referred to herein are trademarks or registered trademarks of their respective companies or mark holders.

Copyright © 2004 by SUPER MICRO COMPUTER INC.
All rights reserved.

Printed in the United States of America

Preface

About This Manual

This manual is written for professional system integrators and PC technicians. It provides information for the installation and use of the SuperWorkstation 7034A-T/7034A-i. Installation and maintenance should be performed by experienced technicians only.

The SuperWorkstation 7034A-T/7034A-i is a high-end, dual processor tower workstation based on the SC733T-645/SC733i-645 chassis and the X6DAL-TG/X6DAL-G, a dual processor serverboard that supports single or dual Intel Xeon™ processors at a Front Side (System) Bus speed of 800 MHz and up to 12/24 GB of registered ECC DDR333/266 SDRAM.

Manual Organization

Chapter 1: Introduction

The first chapter provides a checklist of the main components included with the server system and describes the main features of the X6DAL-TG/X6DAL-G serverboard and the SC733T-645/SC733i-645 chassis, which comprise the SuperWorkstation 7034A-T/7034A-i.

Chapter 2: Server Installation

This chapter describes the steps necessary to set up and check out the configuration of the SuperWorkstation 7034A-T/7034A-i prior to powering up the system. If your system was ordered without processor and memory components, this chapter will refer you to the appropriate sections of the manual for their installation.

Chapter 3: System Interface

Refer here for details on the system interface, which includes the functions and information provided by the control panel on the chassis as well as other LEDs located throughout the system.

Chapter 4: System Safety

You should thoroughly familiarize yourself with this chapter for a general overview of safety precautions that should be followed when installing and servicing the SuperWorkstation 7034A-T/7034A-i.

Chapter 5: Advanced Serverboard Setup

Chapter 5 provides detailed information on the X6DAL-TG/X6DAL-G serverboard, including the locations and functions of connections, headers and jumpers. Refer to this chapter when adding or removing processors or main memory, when adding peripheral drives and when reconfiguring the serverboard.

Chapter 6: Advanced Chassis Setup

Refer to Chapter 6 for detailed information on the SC733T-645/SC733i-645 server chassis. You should follow the procedures given in this chapter when installing, removing or reconfiguring peripheral drives and when replacing system power supply units and cooling fans.

Chapter 7: BIOS

The BIOS chapter includes an introduction to BIOS and provides detailed information on running the CMOS Setup Utility.

Appendix A: BIOS Error Beep/POST Codes

Appendix B: BIOS POST Checkpoint Codes

Appendix C: System Specifications

Notes

Table of Contents

Preface

About This Manual	iii
Manual Organization	iii

Chapter 1: Introduction

1-1 Overview	1-1
1-2 Serverboard Features	1-2
1-3 Server Chassis Features	1-3
1-4 Contacting Supermicro	1-5

Chapter 2: Server Installation

2-1 Overview	2-1
2-2 Unpacking the System	2-1
2-3 Preparing for Setup	2-1
2-4 Checking the Serverboard Setup	2-2
2-5 Checking the Drive Bay Setup	2-4

Chapter 3: System Interface

3-1 Overview	3-1
3-2 Control Panel Buttons	3-1
Power	3-1
Reset	3-1
3-3 Control Panel LEDs	3-2
Power	3-2
HDD	3-2
NIC	3-2
Overheat/Fan Fail	3-2
Power Fail	3-3
3-4 LAN (Ethernet) Port LEDs	3-3

Chapter 4: System Safety

4-1 Electrical Safety Precautions	4-1
4-2 General Safety Precautions	4-2
4-3 ESD Safety Precautions	4-3
4-4 Operating Precautions	4-4

Chapter 5: Advanced Serverboard Setup

5-1	Handling the Serverboard	5-1
5-2	Processor and Heatsink Installation	5-2
5-3	Connecting Cables	5-5
	Connecting Data Cables	5-5
	Connecting Power Cables	5-5
	Connecting the Control Panel	5-6
5-4	I/O Ports	5-7
5-5	Installing Memory	5-7
5-6	Adding PCI Cards	5-9
5-7	Serverboard Details	5-10
	X6DAL-TG/X6DAL-G Layout	5-10
	X6DAL-TG/X6DAL-G Quick Reference	5-11
5-8	Connector Definitions	5-12
	ATX Power Connector	5-12
	Processor Power Connector	5-12
	NMI Button	5-12
	Power LED	5-12
	HDD LED	5-13
	NIC LED	5-13
	Overheat/Fan Fail LED	5-13
	Power Fail LED	5-13
	GLAN1 (Ethernet Port)	5-13
	Reset Button	5-14
	Power Button	5-14
	Chassis Intrusion	5-14
	Universal Serial Bus (USB0/1)	5-14
	Fan Headers	5-15
	Serial Ports	5-15
	ATX PS/2 Keyboard and Mouse Ports	5-15
	Power LED/Speaker/Keylock	5-16
	Wake-On-Ring	5-16
	Wake-On-LAN	5-16
	SATA LED	5-16
	Power Fault	5-17
	SATA SMB (I ² C)	5-17
	SMB Power Connector	5-17
	CD-In Headers	5-17

5-9	Jumper Settings	5-18
	Explanation of Jumpers	5-18
	CMOS Clear	5-18
	Serial ATA Enable/Disable	5-18
	GLAN Enable/Disable	5-19
	Audio Enable/Disable	5-19
	Alarm Reset	5-19
	Power Force On Enable/Disable	5-19
	Watch Dog Enable/Disable	5-20
	AC'97 Audio Enable/Disable	5-20
5-10	Onboard Indicators	5-21
	LAN LEDs	5-21
	Onboard LED Indicators	5-21
	System Alert LED Indicators	5-21
5-11	Floppy and Hard Disk Drive Connections	5-22
	Floppy Connector	5-22
	IDE Connectors	5-23

Chapter 6: Advanced Chassis Setup

6-1	Static-Sensitive Devices	6-1
6-2	Front Control Panel	6-2
6-3	System Fans	6-5
	Fan Failure	6-5
	Replacing System Fans	6-5
6-4	Drive Bay Installation	6-7
	Serial ATA Drives	6-7
	Installing Components in the 5.25" Drive Bays	6-10
6-5	Power Supply	6-11
	Power Supply Failure	6-11
	Replacing the Power Supply	6-11

Chapter 7: BIOS

7-1	Introduction	7-1
7-2	Main Setup	7-2
7-3	Advanced Settings	7-3
7-4	Security Settings	7-23
7-5	Exit Options	7-24

Appendices:

Appendix A: BIOS Error Beep/POST Codes A-1
Appendix B: BIOS POST Checkpoint Codes B-1
Appendix C: System Specifications C-1

Notes

Chapter 1

Introduction

1-1 Overview

The Supermicro SuperWorkstation 7034A-T/7034A-i is a high-end, dual processor workstation in a tower configuration. The 7034A-T/7034A-i is comprised of two main subsystems: the SC733T-645/SC733i-645 high-end server chassis and the X6DAL-TG/X6DAL-G Intel® Xeon™ dual processor serverboard. Please refer to our web site for information on operating systems that have been certified for use with the SuperWorkstation 7034A-T/7034A-i.

In addition to the serverboard and chassis, various hardware components have been included with the 7034A-T/7034A-i, as listed below:

- One (1) 3.5" floppy drive [FPD-TEAC (B)]
- One (1) 9-cm chassis fan (FAN-0076)
- One (1) 12-cm exhaust fan (FAN-0077)
- Two (2) 5.25" dummy IDE disk drive trays [CSE-PT36(B)-OEM]
- One (1) front control panel cable (CBL-0049)
- One (1) round floppy drive cable (CBL-0051)
- One (1) round CD-ROM cable (CBL-0052)
- One (1) I/O shield (CSE-PT2)
- SATA Accessories (7034A-T only)
 - One (1) SATA backplane (CSE-SATA-733)
 - Four (4) SATA cables (CBL-0044)
 - One (1) 10-pin to 10-pin SATA LED cable (CBL-0056)
 - Four (4) 1-inch high SATA drive carriers [CSE-PT-39(B)]
- Optional: Two (2) Xeon 4-wire active heatsinks (SNK-P0008A4)

1-2 Serverboard Features

At the heart of the SuperWorkstation 7034A-T/7034A-i lies the X6DAL-TG/X6DAL-G, a dual processor serverboard based on the Intel E7525 chipset and designed to provide maximum performance. Below are the main features of the X6DAL-TG/X6DAL-G. (See Figure 1-1 for a block diagram of the E7525 chipset).

Processors

The X6DAL-TG/X6DAL-G supports single or dual 604-pin Intel Xeon processors at a FSB speed of 800 MHz. Please refer to the serverboard description pages on our web site for a complete listing of supported processors (www.supermicro.com).

Memory

The X6DAL-TG/X6DAL-G has six 184-pin DIMM slots that can support up to 12 GB of registered ECC DDR333 or 24 GB of registered ECC DDR266 SDRAM. The memory is an interleaved configuration, which requires modules of the same size and speed to be installed in pairs.

PCI Expansion Slots

The X6DAL-TG/X6DAL-G has six PCI expansion slots: one PCI-Express x16, one PCI-Express x8, two PCI-X 66 MHz and two 32-bit 33MHz PCI slots. The SC733T-645/SC733i-645 chassis allows all six slots to be populated.

Serial ATA Subsystem (7034A-T only)

The X6DAL-TG features a Marvell SATA controller, which supports four Serial ATA (SATA) hard drives. The SATA drives are hot-swappable units.

Note: The operating system you use must have RAID support to enable the hot-swap capability of the SATA drives.

Onboard Controllers/Ports

One floppy drive controller and two onboard ATA/100 controllers are provided to support up to four IDE hard drives or ATAPI devices. The color-coded I/O ports include two COM ports, two USB 2.0 ports, PS/2 mouse and keyboard ports, one gigabit Ethernet port and Line-in, Line-out and Mic jacks. Two front side USB ports are included on the front of the chassis.

Other Features

Other onboard features that promote system health include onboard voltage monitors, a chassis intrusion header, auto-switching voltage regulators, chassis and CPU overheat sensors, virus protection and BIOS rescue.

1-3 Server Chassis Features

The SuperWorkstation 7034A-T/7034A-i is a high-end, scaleable tower platform designed with today's most state-of-the-art features. The following is a general outline of the main features of the SC733T-645/SC733i-645 chassis.

System Power

The SuperWorkstation 7034A-T/7034A-i includes a single 645W power supply that features noise-suppression technology for silent operation, making it ideal for workstation a environment.

Front Control Panel

The SuperWorkstation 7034A-T/7034A-i's control panel provides you with system monitoring and control. LEDs indicate system power, HDD activity, network activity and overheat condition. A main power button and a system reset button are also included.

I/O Backplane

The SC733T-645/SC733i-645 is an ATX form factor chassis in a tower configuration. The I/O backplane provides seven motherboard expansion slots, two COM ports, two USB 2.0 ports, PS/2 mouse and keyboard ports, a gigabit Ethernet port and Line-in, Line-out and Mic jacks.

Cooling System

The SC733T-645/SC733i-645 chassis has an innovative cooling design that includes one 9-cm chassis PWM fan located in the front of the chassis and one heavy duty 12-cm exhaust PWM fan. A fan speed setting in BIOS (see p. 7-19) enables the use of PWM. PWM (Pulse Width Modulation) allows fans to run at different speeds according to the temperature. The power supply also has a cooling fan. All fans operate continuously.

[See note on next page regarding 3-pin heatsink fans.](#)

Note: the 4-pin fan headers on the 7034A-T/7034A-i serverboard may present some confusion to users who decide to add CPU heatsinks that have 3-pin fan headers. Heatsinks with 3-pin fan headers may be connected to the serverboard, but these fans will not be controlled by PWM and will constantly run at full speed, which may generate too much noise for the workspace. To remedy this, Supermicro suggests changing the “Auto Fan control” BIOS setting to “3-pin Workstation”, which will cause fan speed to be controlled by temperature sensor/voltage levels and result in lower noise levels.

**Figure 1-1. Intel E7525 Chipset:
System Block Diagram**

Note: This is a general block diagram. Please see Chapter 5 for details.

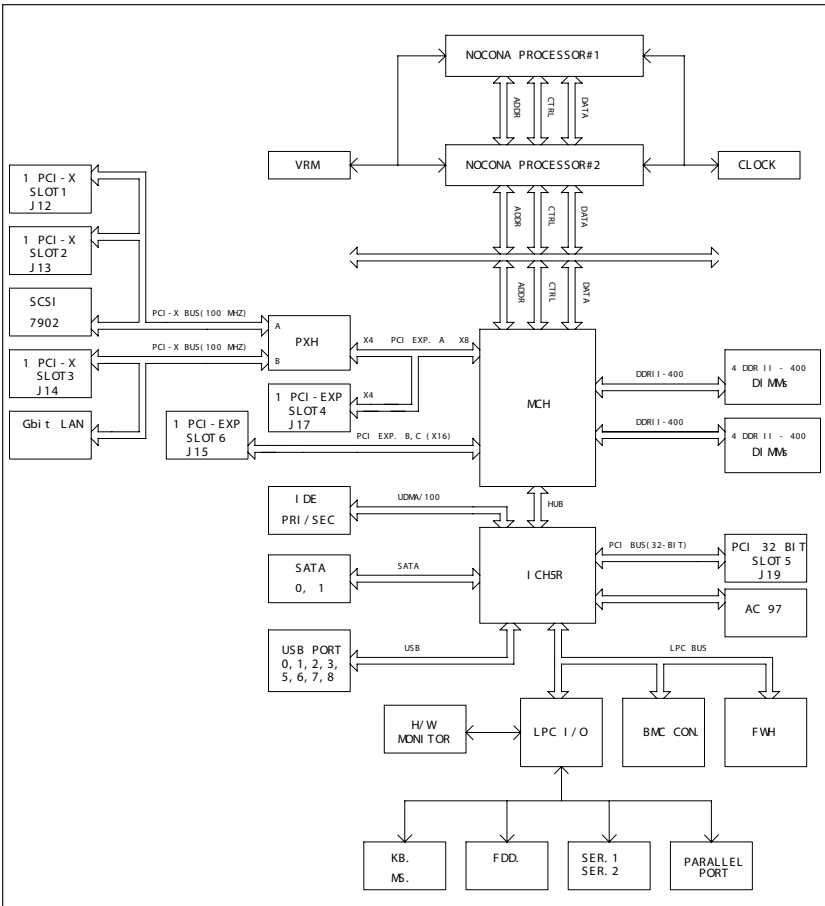

1-4 Contacting Supermicro

Headquarters

Address: SuperMicro Computer, Inc.
980 Rock Ave.
San Jose, CA 95131 U.S.A.

Tel: +1 (408) 503-8000

Fax: +1 (408) 503-8008

Email: marketing@supermicro.com (General Information)
support@supermicro.com (Technical Support)

Web Site: www.supermicro.com

Europe

Address: SuperMicro Computer B.V.
Het Sterrenbeeld 28, 5215 ML
's-Hertogenbosch, The Netherlands

Tel: +31 (0) 73-6400390

Fax: +31 (0) 73-6416525

Email: sales@supermicro.nl (General Information)
support@supermicro.nl (Technical Support)
rma@supermicro.nl (Customer Support)

Asia-Pacific

Address: SuperMicro, Taiwan
D5, 4F, No. 16 Chien-Ba Road
Chung-Ho 235, Taipei Hsien, Taiwan, R.O.C.

Tel: +886-(2) 8226-3990

Fax: +886-(2) 8226-3991

Web Site: www.supermicro.com.tw

Technical Support:

Email: support@supermicro.com.tw

Tel: 886-2-8228-1366, ext.132 or 139

Notes

Chapter 2

Server Installation

2-1 Overview

This chapter provides a quick setup checklist to get your SuperWorkstation 7034A-T/7034A-i up and running. Following these steps in the order given should enable you to have the system operational in a minimal amount of time. This quick setup assumes that your SuperWorkstation 7034A-T/7034A-i system has come to you with the processors and memory preinstalled. If your system is not already fully integrated with a motherboard, processors, system memory etc., please turn to the chapter or section noted in each step for details on installing specific components.

2-2 Unpacking the System

You should inspect the box the SuperWorkstation 7034A-T/7034A-i was shipped in and note if it was damaged in any way. If the workstation itself shows damage you should file a damage claim with the carrier who delivered it.

2-3 Preparing for Setup

Choosing a Setup Location

Decide on a suitable location for the SuperWorkstation 7034A-T/7034A-i. It should be situated in a clean, dust-free area that is well ventilated. Avoid areas where heat, electrical noise and electromagnetic fields are generated. You will also need it placed near a grounded power outlet. Once the system has been placed in the appropriate location, slide the locking tabs on each caster down to keep it stationary.

Server Precautions

- Review the electrical and general safety precautions in Chapter 4.
- Use a regulating uninterruptible power supply (UPS) to protect the server from power surges, voltage spikes and to keep your system operating in case of a power failure.
- Allow the power supply unit and the SATA hard drives (7034A-T only) to cool before touching them.
- Always keep the chassis front door and all panels closed when not servicing to maintain proper cooling.

2-4 Checking the Serverboard Setup

After setting up the the 7034A-T/7034A-i, you will need to gain access to the inside of the chassis to make sure the serverboard is properly installed and the essential connections have been made. Begin by opening the left side panel (when facing the front of the chassis). Refer to Figure 2-1 for the following steps.

1. Remove the left side panel of the chassis

First, remove the two screws that secure the back lip of the side panel to the rear of the chassis. Then grasp the handle at the rear of the panel and pull straight back about 1/2 inch, at which point the panel should hit a stop. Swing the top of the panel out and completely lift it away from the chassis. When reinstalling this panel, make sure the raised holes along the bottom of the chassis fit into the long holes in the bottom lip of the side panel.

2. Check the CPUs (processors)

You should have one or two processors already installed into the system board. Each processor should have its own heatsink attached. See Chapter 5 for instructions on processor installation.

3. Check the system memory

Your 7034A-T/7034A-i workstation may have come with system memory already installed. Make sure all DIMMs are fully seated in their slots. For details on adding system memory, refer to Chapter 5.

4. Installing add-on cards

If desired, you can install add-on cards to the system. See Chapter 5 for details on installing PCI add-on cards.

5. Check all cable connections and airflow

Make sure all power and data cables are properly connected and not blocking the chassis airflow. See Chapter 5 for details on cable connections.

Figure 2-1. Accessing the Inside of the 7034A-T/7034A-i

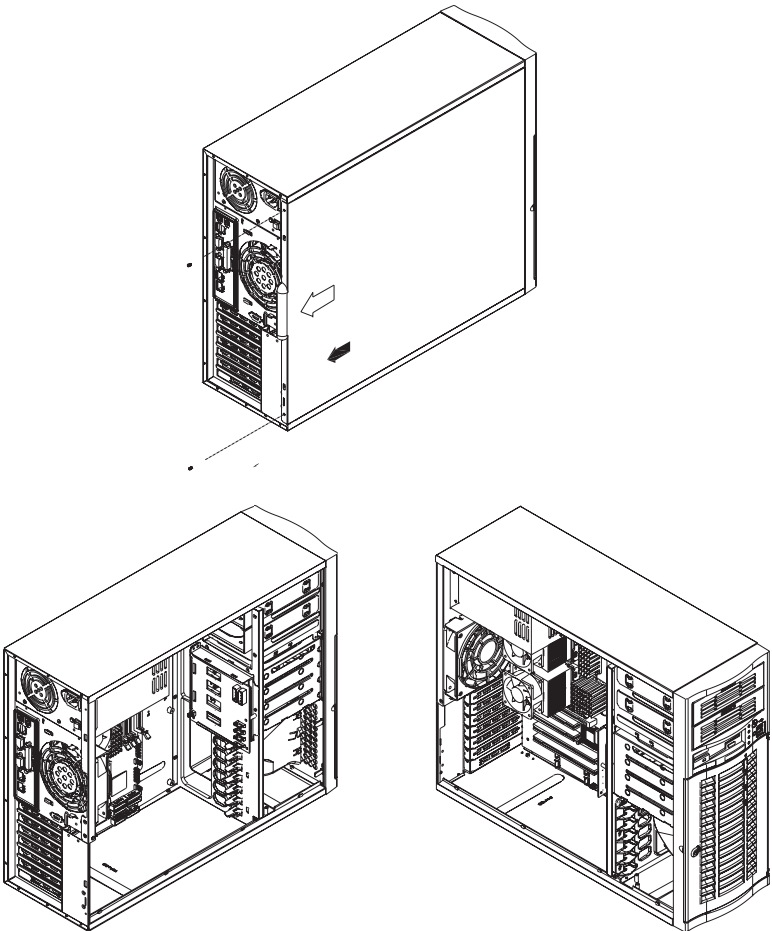

2-5 Checking the Drive Bay Setup

Next, you should check to make sure the peripheral drives have been properly installed and all connections have been made.

1. Accessing the drive bays

All drives can be accessed from the front of the server. When installing or removing the CD-ROM, IDE hard drives or a floppy drive, you will also need to remove the left chassis cover (not necessary for SATA drives).

2. Installing components into a 5.25" drive bay

To install components into one of the 5.25" drive bays, you must first remove the left chassis cover as described in the previous section. Refer to Chapter 6 for details.

3. Installing CD-ROM and floppy disk drives

Refer to Chapter 6 if you need to reinstall a CD-ROM and/or a floppy disk drive to the system.

4. Check the SATA/IDE disk drives

Depending upon your the configuration, your system may have one or more SATA (7034A-T) or IDE (7034A-i) hard drives already installed. If you need to install an SATA or IDE hard drive, please refer to Chapter 6.

5. Check the airflow

Airflow is provided by one 9-cm chassis cooling PWM fan and a 12-cm PWM exhaust fan. The system component layout was carefully designed to promote sufficient airflow through the chassis interior. A specially designed air shroud enables the 9 3/8" fan to sufficiently supply cool air to all system components. Also note that all power and data cables have been routed in such a way that they do not block the airflow generated by the fans. Keep this in mind when you reroute them after working on the system.

6. Supplying power to the system:

The last thing you must do is to provide input power to the system. Plug the power cord from the power supply unit into a high-quality power strip that offers protection from electrical noise and power surges. It is recommended that you use an uninterruptible power supply (UPS). Finally, depress the power on button on the front of the chassis.

Chapter 3

System Interface

3-1 Overview

There are several LEDs on the control panel to keep you constantly informed of the overall status of the system and the activity and health of specific components. There are also two buttons on the chassis control panel.

3-2 Control Panel Buttons

There are two push buttons located on the front of the chassis. These are (in order from top to bottom) a power on/off button and a reset button.



- **POWER:** This is the main power button, which is used to apply or turn off the main system power. Turning off system power with this button removes the main power but keeps standby power supplied to the system.



- **RESET:** Use the reset button to reboot the system.

3-3 Control Panel LEDs

The control panel located on the front of the SC733T-645/SC733i-645 chassis has four LEDs that provide you with critical information related to different parts of the system. This section explains what each LED indicates when illuminated and any corrective action you may need to take.



- **Power:** Indicates external power is being supplied to the system's power supply unit. This LED should normally be illuminated when the system is operating.



- **HDD:** Indicates IDE channel activity. On the SuperWorkstation 7034A-T/7034A-i, this LED indicates SATA/IDE drive activity when flashing.



- **NIC:** Indicates network activity on the GLAN when flashing.



- **Overheat/Fan Fail:** When this LED flashes it indicates a fan failure. When on continuously (on and not flashing) it indicates an overheat condition, which may be caused by cables obstructing the airflow in the system or the ambient room temperature being too warm. Check the routing of the cables and make sure all fans are present and operating normally. You should also check to make sure that the chassis covers are installed. Finally, verify that the heatsinks are installed properly (see Chapter 5). This LED will remain flashing or on as long as the overheat condition exists.

3-4 LAN (Ethernet) Port LEDs

The LAN port has a yellow and a green LED. The yellow (left) LED indicates activity while the other (right) LED may be green, orange or off to indicate the speed of the connection. See the tables below for the functions associated with these LEDs.

**Gb LAN Left LED
Indicator**

LED Color	Definition
Off	Not Active
Yellow	Active

**Gb LAN Right LED
Indicator**

LED Color	Definition
Off	No Connection
Green	100 MHz
Orange	1 GHz

Notes

Chapter 4

System Safety

4-1 Electrical Safety Precautions



Basic electrical safety precautions should be followed to protect yourself from harm and the SuperWorkstation 7034A-T/7034A-i from damage:

- Be aware of the locations of the power on/off switch on the chassis as well as the room's emergency power-off switch, disconnection switch or electrical outlet. If an electrical accident occurs, you can then quickly remove power from the system.
- Do not work alone when working with high voltage components.
- Power should always be disconnected from the system when removing or installing main system components, such as the serverboard, memory modules and the CD-ROM and floppy drives. When disconnecting power, you should first power down the system with the operating system and then unplug the power cords of all the power supply units in the system.
- When working around exposed electrical circuits, another person who is familiar with the power-off controls should be nearby to switch off the power if necessary.
- Use only one hand when working with powered-on electrical equipment. This is to avoid making a complete circuit, which will cause electrical shock. Use extreme caution when using metal tools, which can easily damage any electrical components or circuit boards they come into contact with.
- Do not use mats designed to decrease electrostatic discharge as protection from electrical shock. Instead, use rubber mats that have been specifically designed as electrical insulators.

- The power supply power cord must include a grounding plug and must be plugged into grounded electrical outlets.
- Serverboard Battery: **CAUTION** - There is a danger of explosion if the onboard battery is installed backwards, which will reverse its polarities. The positive side of the battery should be facing up and the negative side should facing the serverboard. This battery must be replaced only with the same or an equivalent type recommended by the manufacturer. Dispose of used batteries according to the manufacturer's instructions.
- CD-ROM Laser: **CAUTION** - this server may have come equipped with a CD-ROM drive. To prevent direct exposure to the laser beam and hazardous radiation exposure, do not open the enclosure or use the unit in any unconventional way.

4-2 General Safety Precautions



Follow these rules to ensure general safety:

- Keep the area around the SuperWorkstation 7034A-T/7034A-i clean and free of clutter.
- The SuperWorkstation 7034A-T/7034A-i weighs approximately 40 lbs. When lifting the system, two people at either end should lift slowly with their feet spread out to distribute the weight. Always keep your back straight and lift with your legs.
- Place the chassis top/side cover and any system components that have been removed away from the system or on a table so that they won't accidentally be stepped on.
- While working on the system, do not wear loose clothing such as neckties and unbuttoned shirt sleeves, which can come into contact with electrical circuits or be pulled into a cooling fan.
- Remove any jewelry or metal objects from your body, which are excellent metal conductors that can create short circuits and harm you if they come into contact with printed circuit boards or areas

where power is present.

- After accessing the inside of the system, close the system back up and (if rackmounted) secure it to the rack unit with the retention screws after ensuring that all connections have been made.

4-3 ESD Precautions



Electrostatic discharge (ESD) is generated by two objects with different electrical charges coming into contact with each other. An electrical discharge is created to neutralize this difference, which can damage electronic components and printed circuit boards. The following measures are generally sufficient to neutralize this difference before contact is made to protect your equipment from ESD:

- Use a grounded wrist strap designed to prevent static discharge.
- Keep all components and printed circuit boards (PCBs) in their antistatic bags until ready for use.
- Touch a grounded metal object before removing the board from the antistatic bag.
- Do not let components or PCBs come into contact with your clothing, which may retain a charge even if you are wearing a wrist strap.
- Handle a board by its edges only; do not touch its components, peripheral chips, memory modules or contacts.
- When handling chips or modules, avoid touching their pins.
- Put the serverboard and peripherals back into their antistatic bags when not in use.

- For grounding purposes, make sure your computer chassis provides excellent conductivity between the power supply, the case, the mounting fasteners and the serverboard.

4-4 Operating Precautions



Care must be taken to assure that all chassis covers are in place when the 7034A-T/7034A-i is operating to ensure proper cooling. Out of warranty damage to the 7034A-T/7034A-i system can occur if this practice is not strictly followed.

Chapter 5

Advanced Serverboard Setup

This chapter covers the steps required to install processors and heatsinks to the X6DAL-TG/X6DAL-G serverboard, connect the data and power cables and install add-on cards. All serverboard jumpers and connections are described and a layout and quick reference chart are included in this chapter. Remember to close the chassis completely when you have finished working on the serverboard to protect and cool the system sufficiently.

5-1 Handling the Serverboard

Static electrical discharge can damage electronic components. To prevent damage to printed circuit boards, it is important to handle them very carefully (see Chapter 4). Also note that the size and weight of the serverboard can cause it to bend if handled improperly, which may result in damage. To prevent the serverboard from bending, keep one hand under the center of the board to support it when handling. The following measures are generally sufficient to protect your equipment from static discharge.

Precautions

- Use a grounded wrist strap designed to prevent static discharge.
- Touch a grounded metal object before removing any board from its anti-static bag.
- Handle a board by its edges only; do not touch its components, peripheral chips, memory modules or gold contacts.
- When handling chips or modules, avoid touching their pins.
- Put the serverboard, add-on cards and peripherals back into their anti-static bags when not in use.

Unpacking

The serverboard is shipped in antistatic packaging to avoid static damage. When unpacking the board, make sure the person handling it is static protected.

5-2 Processor and Heatsink Installation



When handling the processor package, avoid placing direct pressure on the label area of the fan. Also, do not place the serverboard on a conductive surface, which can damage the BIOS battery and prevent the system from booting up.

IMPORTANT: Always connect the power cord last and always remove it before adding, removing or changing any hardware components. Make sure that you install the processor into the CPU socket **before** you install the CPU heat sink.

CPU Installation

1. Lift the lever on the CPU socket:

Lift the lever completely as shown on the picture on the right; otherwise, you will damage the CPU socket when power is applied. Install CPU1 first.



Socket lever

2. Insert the CPU in the socket, making sure that pin 1 of the CPU aligns with pin 1 of the socket (both corners are marked with a triangle). When using only one CPU, install it into CPU socket #1. (Socket #2 is automatically disabled if only one CPU is used.)



Pin 1

3. Press the lever down until you hear a *click*, which means the CPU is securely installed in the CPU socket.



Socket lever in the locking Position

Heatsink Installation*

1. Do not apply any thermal compound to the heatsink or the CPU die; the required amount has already been applied.
2. Place the heatsink on top of the CPU so that the four mounting holes are aligned with those on the retention mechanism.
3. Screw in two diagonal screws (ie the #1 and the #2 screws) until just snug (-do not fully tighten the screws to avoid possible damage to the CPU.)
4. Finish the installation by fully tightening all four screws.

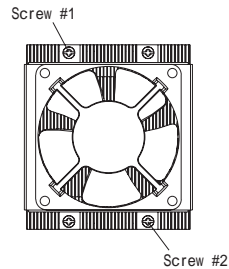
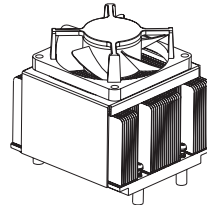

*Heatsink package is optional.

*Fan speed is controlled by a setting in BIOS (see page 7-19).

Figure 5-1. 604-pin PGA Socket: Empty and with Processor Installed



Warning! Make sure you lift the lever completely when installing the CPU. If the lever is only partly raised, damage to the socket or CPU may result.

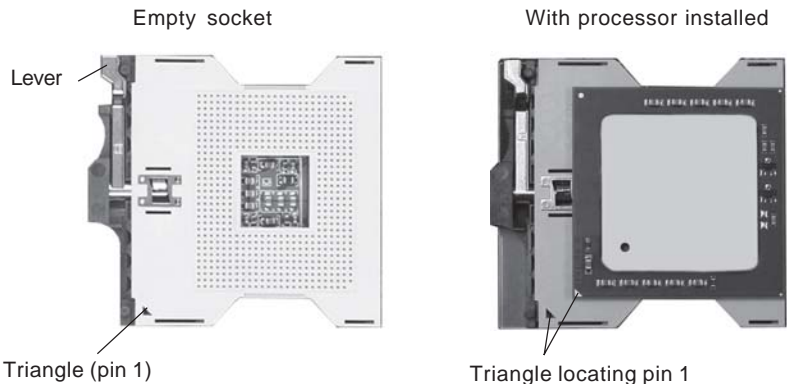

Removing the Heatsink/CPU



IMPORTANT: Removal of the heatsink or the CPU is not recommended. However, if you do need to remove the heatsink, please follow the instructions below to prevent damaging the CPU or the CPU socket.

1. Unscrew and remove the heatsink screws from the serverboard in the sequence as show in the picture on the right.

2. Hold the heatsink and gently wiggle it back and forth to loosen it from the CPU. (Do not use excessive force when loosening the heatsink!!)

3. Once the heatsink has been loosened from the CPU, remove the heatsink from the CPU socket.

4. Clean the surface of the CPU and the heatsink to get rid of the old thermal grease. Reapply the proper amount of thermal grease on the surface before you re-install the heatsink to the CPU.

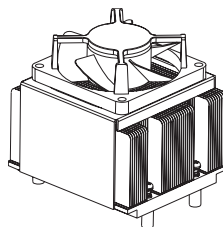
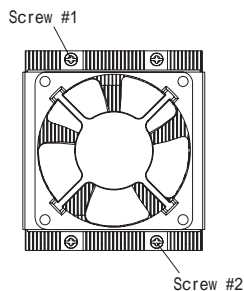

5-3 Connecting Cables

Now that the processors are installed, the next step is to connect the cables to the serverboard. These include the data (ribbon) cables for the peripherals and control panel and the power cables.

Connecting Data Cables

The ribbon cables used to transfer data from the peripheral devices have been carefully routed in preconfigured systems to prevent them from blocking the flow of cooling air that moves through the system from front to back. If you need to disconnect any of these cables, you should take care to keep them routed as they were originally after reconnecting them (make sure the red wires connect to the pin 1 locations). If you are configuring the system, keep the airflow in mind when routing the cables. The following data cables (with their serverboard connector locations noted) should be connected. See the serverboard layout figure in this chapter for connector locations.

- SATA drive cable (J52-J55, 7034A-T)
- IDE drive cable (JA1, 7034A-i)
- Control Panel cable (JF1, see next page)
- Front Side USB cable (J42)
- Floppy drive cable (J24)

Connecting Power Cables

The X6DAL-TG/X6DAL-G has a 24-pin primary power supply connector designated "ATX Power" for connection to the ATX power supply. Connect the appropriate connector from the power supply to the "ATX Power" connector to supply power to the serverboard. The 12V 8-pin power connector at PWR2 and the 12V 4-pin power connector at PWR3 must also both be connected to your power supply. See the Connector Definitions section in this chapter for power connector pin definitions.

Connecting the Control Panel

JF1 contains header pins for various front control panel connectors. See Figure 5-2 for the pin locations of the various front control panel buttons and LED indicators. Please note that even and odd numbered pins are on opposite sides of each header.

All JF1 wires have been bundled into single ribbon cable to simplify their connection. Make sure the red wire plugs into pin 1 as marked on the board. The other end connects to the Control Panel printed circuit board, located just behind the system status LEDs in the chassis.

See the Connector Definitions section in this chapter for details and pin descriptions of JF1.

Figure 5-2. JF1 Header Pins

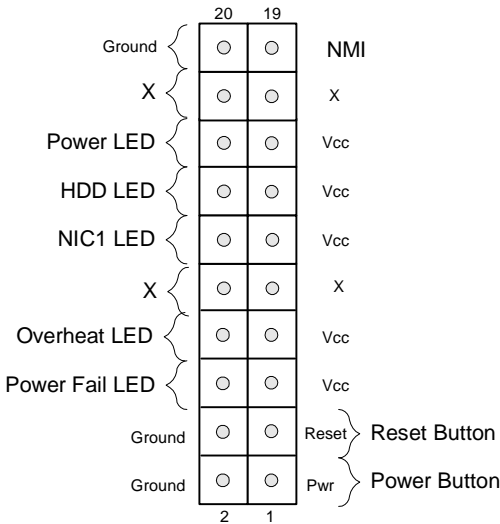

5-4 I/O Ports

The I/O ports are color coded in conformance with the PC 99 specification. See Figure 5-3 below for the colors and locations of the various I/O ports.

Figure 5-3. Rear Panel I/O Ports

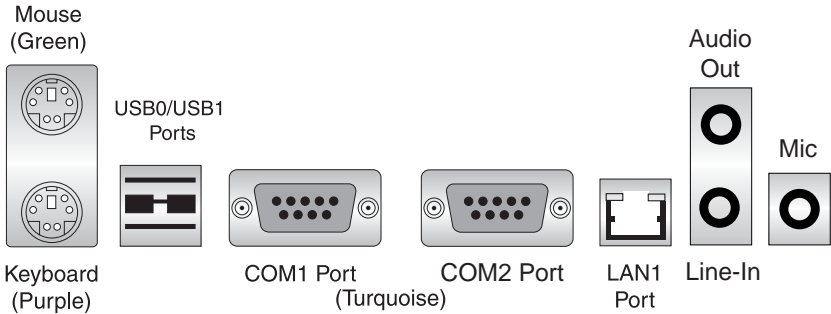

5-5 Installing Memory

Note: Check the Supermicro web site for recommended memory modules:
http://www.supermicro.com/TECHSUPPORT/FAQs/Memory_vendors.htm

CAUTION

Exercise extreme care when installing or removing DIMM modules to prevent any possible damage. Also note that the memory is interleaved to improve performance (see step 1).

DIMM Installation (See Figures 5-4 and 5-5)

1. Insert the desired number of DIMMs into the memory slots, starting with Bank #1A. The memory scheme is interleaved so you must install two modules at a time, beginning with DIMM #1A, then DIMM #1B, and so on.
2. Insert each DIMM module vertically into its slot. Pay attention to the notch along the bottom of the module to prevent inserting the DIMM module incorrectly.
3. Gently press down on the DIMM module until it snaps into place in the slot. Repeat for all modules (see step 1 above).

Memory Support

The X6DAL-TG/X6DAL-G supports up to 12/24 GB of registered ECC DDR333/266 (PC2700/PC2100) SDRAM memory. The serverboard was designed to support 4 GB DDR266 modules in each slot but has only been verified with 2 GB modules. When using registered ECC DDR333 memory, both four double-banked DIMMs and six single-banked DIMMs are supported.

Figure 5-4. Side View of DIMM Installation into Slot

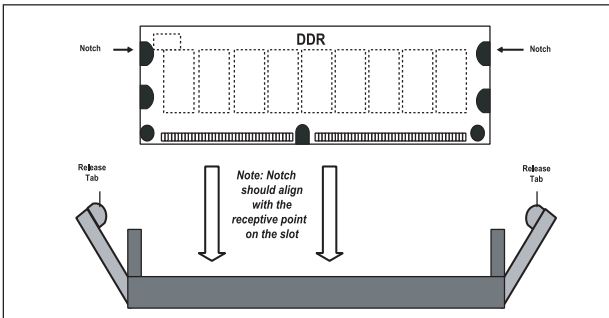

To Install: Insert module vertically and press down until it snaps into place. Pay attention to the bottom notch.

To Remove: Use your thumbs to gently push each release tab outward to free the DIMM from the slot.

Figure 5-5. Top View of DIMM Slot

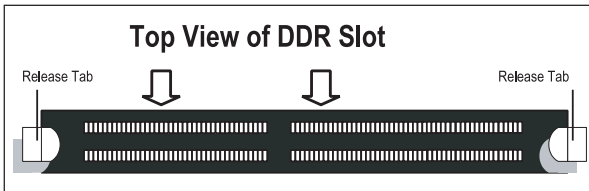

5-6 Adding PCI Cards

1. PCI slots:

The X6DAL-TG/X6DAL-G has six PCI expansion slots, which includes one PCI-Express x16 slot, one PCI-Express x8 slot, two PCI-X 66 MHz slots and two 32-bit 33MHz PCI slots. The SC733T-645/SC733i-645 chassis allows all six slots to be populated.

2. PCI card installation:

Before installing a PCI add-on card, make sure you install it into a slot that supports the speed of the card (see step 1, above). Begin by removing the screw from the I/O backpanel shield that corresponds to the slot you wish to populate. Insert the PCI card into the correct slot on the serverboard, pushing down with your thumbs evenly on both sides of the card. Finish by securing the card to the chassis with the same screw you removed from the I/O shield. Follow this procedure when adding a card to other slots.

5-7 Serverboard Details

Figure 5-6. SUPER X6DAL-TG/X6DAL-G Layout*
(not drawn to scale)

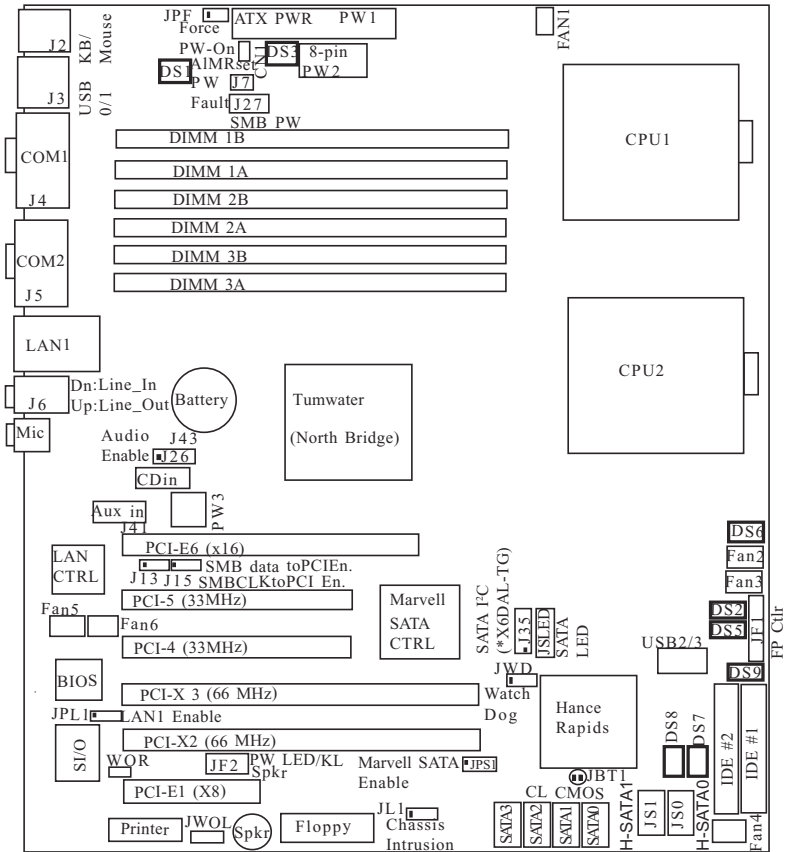

***Notes:**

Jumpers not noted are for test purposes only.

"■" indicates the location of Pin 1.

SATA controllers and connections do not apply to the X6DAL-G.

X6DAL-TG/X6DAL-G Quick Reference

<u>Jumper</u>	<u>Description</u>	<u>Default Setting</u>
CN1	Alarm Reset	Open (Disabled)
J13	SMB Data to PCI Enable/Disable	Closed (Enabled)
J15	SMB Clock to PCI Enable/Disable	Closed (Enabled)
J26	Audio Enable/Disable	Closed (Enabled)
JBT1	CMOS Clear	See Section 5-9
JPF	Force Power On Enable/Disable	Open (Disabled)
JPL1	LAN1 Enable/Disable	Pins 1-2 (Enabled)
JPS1*	SATA Controller Enable/Disable	Pins 1-2 (Enabled)
JWD	Watch Dog	Pins 2-3 (NMI)

<u>Connector</u>	<u>Description</u>
ATX PWR	Primary 24-pin ATX PWR Connector
DIMM#1A-#3B	Memory (DIMM) Slots
DS7/DS8	POST Code LEDs (see Appendix A)
FAN#1-#6	CPU/Chassis Fan Headers
IDE1, IDE2	IDE1/2 Hard Disk Drive Connectors
J2	Keyboard/Mouse Ports
J4/J5	COM1/COM2 Serial Port Connectors
J6	Bottom: Line In Top: Line Out
J7	Power Fault Header
J24	Floppy Disk Drive Connector
J27	Power System Management
J35	SATA SMB (I ² C) Header
J41	Auxiliary In
J50	CD In
J52-J55	SATA Ports 0/1/2/3 (Marvel Controller)
J61	Microphone
JF1	Front Panel Control Header
JF2	Speaker, PWR LED, Keylock
JL1	Chassis Intrusion Header
JS0/JS1	Hance Rapids SATA Ports 0/1
JSLED*	SATA LED Header
LAN1	Gigabit Ethernet Port
PWR2	12V 8-pin CPU Power Connector
PWR3	12V 4-pin Power Connector
USB 0/1	Back Panel Universal Serial Bus Ports
USB 2/3 (J42)	Front Panel Universal Serial Bus Ports
WOL (JWOL)	Wake-on-LAN
WOR (JWOR)	Wake-on-Ring Header

*X6DAL-TG only

5-8 Connector Definitions

ATX Power Connector

The X6DAL-TG/X6DAL-G includes a 24-pin main power supply connector (PW1) and a 4-pin CPU PWR connector (PWR3). Both connections are required. These power connectors meet the SSI EPS 12V specification. See the table on the right for pin definitions. For CPU PWR (PW2), please refer to the item listed below.

Processor Power Connector

In addition to the Primary ATX power connector (above), the 12v 8-pin processor power connector at PWR2 must also be connected to your power supply. See the table on the right for pin definitions.

NMI Button

The non-maskable interrupt button header is located on pins 19 and 20 of JF1. Refer to the table on the right for pin definitions.

Power LED

The Power LED connection is located on pins 15 and 16 of JF1. Refer to the table on the right for pin definitions.

**ATX Power Supply 24-pin Connector
Pin Definitions (PW1)**

Pin Number	Definition	Pin Number	Definition
13	+3.3V	1	+3.3V
14	-12V	2	+3.3V
15	COM	3	COM
16	PS_ON#	4	+5V
17	COM	5	COM
18	COM	6	+5V
19	COM	7	COM
20	Res(NC)	8	PWR_OK
21	+5V	9	5VSB
22	+5V	10	+12V
23	+5V	11	+12V
24	COM	12	+3.3V

**+12V 4-pin Connector
(PWR3)**

Required Connection	Pins #	Definition
	1 & 2	Ground
	3 & 4	+12 V

**CPU 8-pin PWR
Connector (PWR2)**

Required Connection	Pins	Definition
	1 thru 4	Ground
	5 thru 8	+12v

**NMI Button Pin
Definitions (JF1)**

Pin Number	Definition
19	Control
20	Ground

**PWR_LED Pin Definitions
(JF1)**

Pin Number	Definition
15	Vcc
16	Control

HDD LED

The HDD LED connection is located on pins 13 and 14 of JF1. Attach the hard drive LED cable to these pins to display hard disk drive activity. Refer to the table on the right for pin definitions.

**HDD LED Pin
Definitions
(JF1)**

Pin Number	Definition
13	Vcc
14	HD Active

NIC LED

The NIC (Network Interface Controller) LED connection for the GLAN port is located on pins 11 and 12 of JF1. Attach the NIC LED cable to display network activity. Refer to the table on the right for pin definitions.

**NIC1 LED Pin
Definitions
(JF1)**

Pin Number	Definition
9/11	Vcc
10/12	GND

Overheat/Fan Fail LED

Connect an LED to the OH connection on pins 7 and 8 of JF1 to provide advanced warning of chassis overheating. The LED will blink as long as an overheat condition exists. Refer to the table on the right for pin definitions.

**Overheat (OH) LED
Pin Definitions
(JF1)**

Pin Number	Definition
7	Vcc
8	GND

Power Fail LED

The Power Fail LED connection is located on pins 5 and 6 of JF1. Refer to the table on the right for pin definitions.

**Power Fail LED Pin
Definitions
(JF1)**

Pin Number	Definition
5	Vcc
6	GND

GLAN1 (Ethernet Port)

A gigabit Ethernet port (designated LAN1) is located on the I/O backplane. This port accepts RJ45 type cables.



Reset Button

The Reset Button connection is located on pins 3 and 4 of JF1. Attach it to the hardware reset switch on the computer case. Refer to the table on the right for pin definitions.

**Reset Pin
Definitions
(JF1)**

Pin Number	Definition
3	Reset
4	Ground

Power Button

The Power Button connection is located on pins 1 and 2 of JF1. Momentarily contacting both pins will power on/off the system. To turn off the power when set to suspend mode, depress the button for at least 4 seconds. Refer to the table on the right for pin definitions.

**Power Button
Connector
Pin Definitions
(JF1)**

Pin Number	Definition
1	PW_ON
2	Ground

Chassis Intrusion

A Chassis Intrusion header is located at JL1. Attach the appropriate cable to inform you of a chassis intrusion.

**Chassis Intrusion
Pin Definitions (JL1)**

Pin Number	Definition
1	Intrusion Input
2	Ground

Universal Serial Bus (USB0/1)

There are two Universal Serial Bus ports (USB0/1) located on the I/O panel and an additional two (USB2/3) next to the IDE2 header. USB2/3 can be used to provide front side chassis access (cables not included). See the tables on the right for pin definitions.

USB Pin Definitions

USB0/1 (Back Panel USB)

Pin#	Definition
1	+5V
2	PO-
3	PO+
4	Ground

USB2/3 (FP USB)

Pin Number	Definition	Pin Number	Definition
1	+5V	2	+5V
3	PO-	4	PO-
5	PO+	6	PO+
7	Ground	8	Ground
		10	Ground

Fan Headers

There are six fan headers (FAN1-FAN6) on the X6DAL-TG/X6DAL-G. See the table on the right for pin definitions.

Fan Header Pin Definitions

Pin #	Definition
1	Ground (black)
2	+12V (red)
3	Tachometer
4	PWR_Control

Caution: These fan headers use DC power.

Note: These fan headers are 4-pin fans. Pins#1-#3 of the fan headers are backward compatible with traditional 3-pin fans. Fan speed is controlled by Thermal Management via a Hardware Monitor and BIOS (Advanced Setting). The default setting is disabled. When using a Thermal Management setting, please use all 3-pin fans or all 4-pin fans on the serverboard. Do not use 3-pin fans and 4-pin fans on the same board.

Serial Ports

The COM1 (J4) and COM2 (J5) serial ports are located under the parallel port (see Figure 5-3). See the table on the right for pin definitions.

**Serial Port Pin Definitions
(COM1, COM2)**

Pin Number	Definition	Pin Number	Definition
1	DCD	6	CTS
2	DSR	7	DTR
3	Serial In	8	RI
4	RTS	9	Ground
5	Serial Out	10	NC

ATX PS/2 Keyboard and PS/2 Mouse Ports

The ATX PS/2 keyboard and PS/2 mouse are located on J2. See the table at right for pin definitions. (See Figure 5-3 for the location of each.)

**PS/2 Keyboard and Mouse Port Pin Definitions
(J2)**

Pin Number	Definition
1	Data
2	NC
3	Ground
4	VCC
5	Clock
6	NC

Power LED/Speaker/Keylock

On the JF2 header, pins 1, 3, 5 and 7 are for the speaker, pins 2, 4 and 6 are for the power LED and pins 8 and 9 are for the keylock. See the table on the right for speaker pin definitions. **Note:** The speaker connector pins are for use with an external speaker. If you wish to use the onboard speaker, you should close pins 5-7 with a jumper.

Speaker Connector Pin Definitions (JF2)

Pin Number	Function	Definition
4	+	Red wire, Speaker data
5	Key	No connection
6		Key
7		Speaker data

Wake-On-Ring

The Wake-On-Ring header (designated JWOR) allows your computer to receive and "wake-up" by an incoming call to the modem when in suspend state. See the table on the right for pin definitions. You must have a Wake-On-Ring card and cable to use this feature.

Wake-on-Ring Pin Definitions (JWOR)

Pin Number	Definition
1	Ground
2	Wake-up

Wake-On-LAN

The Wake-On-LAN header is located at JWOL. See the table on the right for pin definitions. You must enable the LAN Wake-Up setting in BIOS to use this function. (You must also have a LAN card with a Wake-On-LAN connector and cable.)

Wake-On-LAN Pin Definitions (JWOL)

Pin Number	Definition
1	+5V Standby
2	Ground
3	Wake-up

SATA LED Header (X6DAL-TG only)

An SATA LED header is located at JSLED. See the table on the right for speaker pin definitions.

SATA LED Pin Definitions (JSLED)

Pin#	Definition
1	Marvell SATA HD0 Active LED
2	Marvell SATA HD1 Active LED
3	Marvell SATA HD2 Active LED
4	Marvell SATA HD3 Active LED
5	All Marvell SATA Ports Active LED
6	Hance Rapid's SATA Active LED
7	Hance Rapid's SATA Active LED

Power Fault

Connect a cable from your power supply to the Power Fail header (J7) to provide warning of power supply failure. This warning signal is passed through the PWR_LED pin to indicate of a power failure on the chassis. See the table on the right for pin definitions.

**Power Fail
Pin Definitions (J7)**

Pin Number	Definition
1	P/S 1 Fail Signal
2	P/S 2 Fail Signal
3	P/S 3 Fail Signal
4	Reset (from MB)

Note: This feature is only available when using redundant Supermicro power supplies.

SATA SMB (I²C) (X6DAL-TG only)

An SATA System Management Bus header is located at J35. Connect the appropriate cable here to utilize SATA SMB on your system.

**SATA SMB (J35)
Pin Definitions**

Pin Number	Definition
1	Data
2	Ground
3	Clock

SMB Power (I²C) Connector

An I²C connector (J27), located between the Alarm Reset header and the PWR Fail header monitors the status of the PWR supply, the fans and the system temperature.

**SMB PWR
Pin Definitions (J27)**

Pin #	Definition
1	Clock
2	SMB Data
3	N/A
4	N/A
5	N/A

CD-In Headers

The 4-pin CD header on the serverboard (J50) allows you to use the onboard sound for audio CD playback. Connect the audio cable from your CD drive to the header. See the table at right for pin definitions.

**Audio CD Header Pin Definitions
(J50)**

Pin Number	Definition
1	Left Stereo Signal
2	Ground
3	Ground
4	Right Stereo Signal

**Audio CD Header Pin Definitions
(J50)**

Pin Number	Definition
1	Right Stereo Signal
2	Ground
3	Left Stereo Signal
4	Ground

5-9 Jumper Settings

Explanation of Jumpers

To modify the operation of the serverboard, jumpers can be used to choose between optional settings. Jumpers create shorts between two pins to change the function of the connector. Pin 1 is identified with a square solder pad on the printed circuit board. See the serverboard layout pages for jumper locations.

Note: On two pin jumpers, "Closed" means the jumper is on and "Open" means the jumper is off the pins.

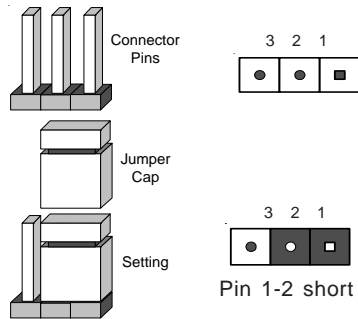

CMOS Clear

JBT1 is used to clear CMOS (which will also clear any passwords). Instead of pins, this jumper consists of contact pads to prevent accidentally clearing the contents of CMOS.

To clear CMOS,

- 1) First unplug the power cord(s)
- 2) With the power disconnected, short the CMOS pads with a metal object such as a small screwdriver
- 3) Remove the screwdriver (or shorting device)
- 4) Reconnect the power cord(s) and power on the system.

Note: Do not use the PW ON connector to clear CMOS.

Serial ATA Enable/Disable (X6DAL-TG only)

Jumper JPS1 allows you to enable or disable the onboard SATA (Marvell) controller ports. See the table on the right for jumper settings. The default setting is enabled.

SATA Enable/Disable Jumper Settings (JPS1)

Jumper Position	Definition
Pins 1-2	Enabled
Pins 2-3	Disabled

GLAN Enable/Disable

Change the setting of jumper JPL1 to enable or disable the onboard GLAN ports (GLAN1 and GLAN2) on the serverboard. See the table on the right for jumper settings. The default setting is enabled

**GLAN
Enable/Disable
Jumper Settings
(JPL1)**

Jumper Position	Definition
Pins 1-2	Enabled
Pins 2-3	Disabled

Audio Enable/Disable

J26 enables or disables the Audio Connector on the serverboard. See the table on the right for jumper settings. The default setting is enabled.

**Audio
Enable/Disable
Jumper Settings
(J26)**

Jumper Position	Definition
Pins 1-2	Enabled
Pins 2-3	Disabled

Alarm Reset

The system will notify you in the event of a power supply failure. This feature assumes that Supermicro redundant power supply units are installed in the chassis. If you only have a single power supply installed, you should disable this (the default setting) with CN1 to prevent false alarms. See the table on the right for jumper settings.

**Alarm Reset Jumper
Settings
(CN1)**

Jumper Position	Definition
Open	Enabled
Closed	Disabled

Power Force On Enable/ Disable

Jumper JPF allows you to enable or disable the Power Force On function. If enabled, the power will always stay on automatically. If this function disabled, the user needs to press the power button to power on the system.

**Force Power On
(JPF)**

Jumper Position	Definition
Open	Normal
Closed	Force On

Watch Dog Enable/Disable

JWD enables the Watch Dog function. Watch Dog is a system monitor that can reboot the system when a software application is "hung up". Pins 1-2 will cause WD to reset the system if an application is hung up. Pins 2-3 will generate a non-maskable interrupt signal for the application that is hung up. See the table on the right for jumper settings. Watch Dog can also be enabled via BIOS.

Note: When enabled, the user needs to write his own application software in order to disable the Watch Dog Timer.

**Watch Dog
Jumper Settings (JWD)**

Jumper Position	Definition
Pins 1-2	WD to Reset
Pins 2-3	WD to NMI
Open	Disabled

AC'97 Audio Enable/Disable

AC'97 provides high quality onboard audio. The X6DAL-TG/X6DAL-G features 6-channel sound for front L&R, rear L&R, center and subwoofer speakers. This feature is activated with the Advanced software on the CD-ROM included with your serverboard. The Line In, Line Out and MIC jacks (see at right) may then be used. Activate AC 97 with the "AC 97 Audio" setting in the Advanced Chipset Features section of BIOS.

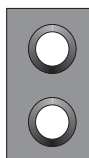

Blue: Line In (surround sound L/R)

Green: Line Out (front L/R)



Pink: MIC In (center/subwoofer)

5-10 Onboard Indicators

LAN LEDs

The Ethernet port has two LEDs. The yellow LED indicates activity while the other LED may be green, orange or off to indicate the speed of the connection. See the table on the right for the functions associated with this second LED.

Gb LAN Right LED Indicator

LED Color	Definition
Off	No Connection
Green	100 MHz
Orange	1 GHz

Onboard LED Indicators (DS1-DS8)

In addition to the LAN LED, there are LED indicators designated DS1-DS3 and DS5-DS8 on the X6DAL-G. See the table on the right for LED definitions.

Onboard LED Definitions (DS1-DS8)

LED	Definition
DS1	CPU PWR good or CPU +12V PWR cable must be connected
DS2	CPU2 VRM Overheat
DS3	CPU1 VRM Overheat
DS5	PWR LED
DS6	CPU Overheat
DS7-8	POST LED

Note: Please refer to Appendix A for DS7 and DS8 LED POST codes.

System Alert LED Indicators (DS9)

A System Alert LED indicator designated DS9 is included on the X6DAL-G. See the table on the right for LED definitions.

System Alert LED Definitions (DS9)

Color	Definition
Green	System: On & OK
Yellow	System: Off, PWR cable connected
Red	PWR or CPU failure

5-11 Floppy and Hard Disk Drive Connections

Note the following when connecting the floppy and hard disk drive cables:

- The floppy disk drive cable has seven twisted wires.
- A red mark on a wire typically designates the location of pin 1.
- A single floppy disk drive ribbon cable has 34 wires and two connectors to provide for two floppy disk drives. The connector with twisted wires always connects to drive A, and the connector that does not have twisted wires always connects to drive B.

Floppy Connector

The floppy connector is located on JD1. See the table below for pin definitions.

Floppy Connector Pin Definitions (JD1)

Pin Number	Function	Pin Number	Function
1	GND	2	FDHDIN
3	GND	4	Reserved
5	Key	6	FDEDIN
7	GND	8	Index-
9	GND	10	Motor Enable
11	GND	12	Drive Select B-
13	GND	14	Drive Select A-
15	GND	16	Motor Enable
17	GND	18	DIR-
19	GND	20	STEP-
21	GND	22	Write Data-
23	GND	24	Write Gate-
25	GND	26	Track 00-
27	GND	28	Write Protect-
29	GND	30	Read Data-
31	GND	32	Side 1 Select-
33	GND	34	Diskette

IDE Connectors

There are no jumpers to configure the onboard IDE#1 and #2 connectors. See the table on the right for pin definitions.

**IDE Connector Pin Definitions
(IDE1, IDE2)**

Pin Number	Function	Pin Number	Function
1	Reset IDE	2	GND
3	Host Data 7	4	Host Data 8
5	Host Data 6	6	Host Data 9
7	Host Data 5	8	Host Data 10
9	Host Data 4	10	Host Data 11
11	Host Data 3	12	Host Data 12
13	Host Data 2	14	Host Data 13
15	Host Data 1	16	Host Data 14
17	Host Data 0	18	Host Data 15
19	GND	20	Key
21	DRQ3	22	GND
23	I/O Write-	24	GND
25	I/O Read-	26	GND
27	IOCHRDY	28	BALE
29	DACK3-	30	GND
31	IRQ14	32	IOCS16-
33	Addr 1	34	GND
35	Addr 0	36	Addr 2
37	Chip Select 0	38	Chip Select 1-
39	Activity	40	GND

Notes

Chapter 6

Advanced Chassis Setup

This chapter covers the steps required to install components and perform simple maintenance on the SC733T-645/SC733i-645 chassis. Following the component installation steps in the order given will eliminate most common problems. If some steps are unnecessary, skip ahead to the next step.

Tools Required

The only tool you will need is a Philips screwdriver.

6-1 Static-Sensitive Devices

Static electrical discharge can damage electronic components. To prevent damage to any printed circuit boards (PCBs), it is important to handle them very carefully. The following measures are generally sufficient to protect your equipment from static discharge.

Precautions

- Use a grounded wrist strap designed to prevent static discharge.
- Touch a grounded metal object before removing any board from its antistatic bag.
- Handle a board by its edges only; do not touch its components, peripheral chips, memory modules or gold contacts.
- When handling chips or modules, avoid touching their pins.
- Put the serverboard, add-on cards and peripherals back into their antistatic bags when not in use.
- For grounding purposes, make sure your computer chassis provides excellent conductivity between the power supply, the case, the mounting fasteners and the serverboard.

Unpacking

The serverboard is shipped in antistatic packaging. When unpacking the board, make sure the person handling it is static protected.

6-2 Front Control Panel

The front control panel must be connected to the JF1 connector on the serverboard to provide you with system status and alarm indications. A ribbon cable has bundled these wires together to simplify this connection. Connect the cable from JF1 on the serverboard (making sure the red wire plugs into pin 1) to the appropriate connector on the front control panel PCB (printed circuit board). Pull all excess cabling over to the control panel side of the chassis. The LEDs inform you of system status - see Figure 6-1 for details.

Refer to Figure 6-2 for the features included on the front of the chassis and to Figure 6-3 for the features on the rear of the chassis. See Chapter 5 for details on JF1.

Figure 6-1. Front Control Panel LEDs





Power		Indicates power is being supplied to the system.
HDD		Indicates SATA/IDE/CD-ROM drive activity.
NIC		Indicates network activity on the GLAN port.
Overheat/Fan Fail		Indicates an overheat condition or a fan failure. Flashing: fan failure On (not flashing): overheat Off: normal

Figure 6-2. Chassis Front View

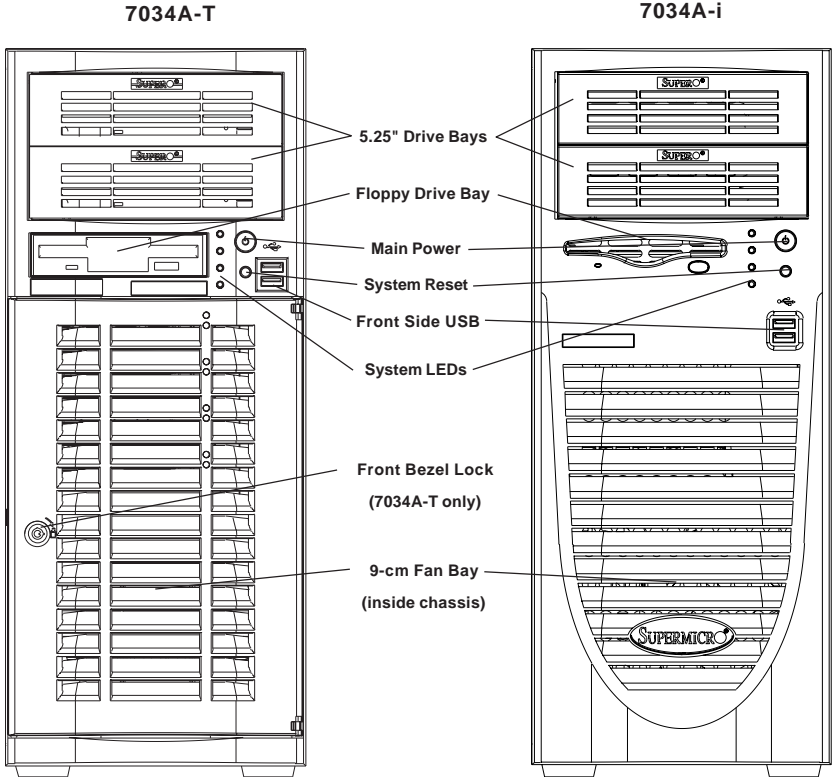
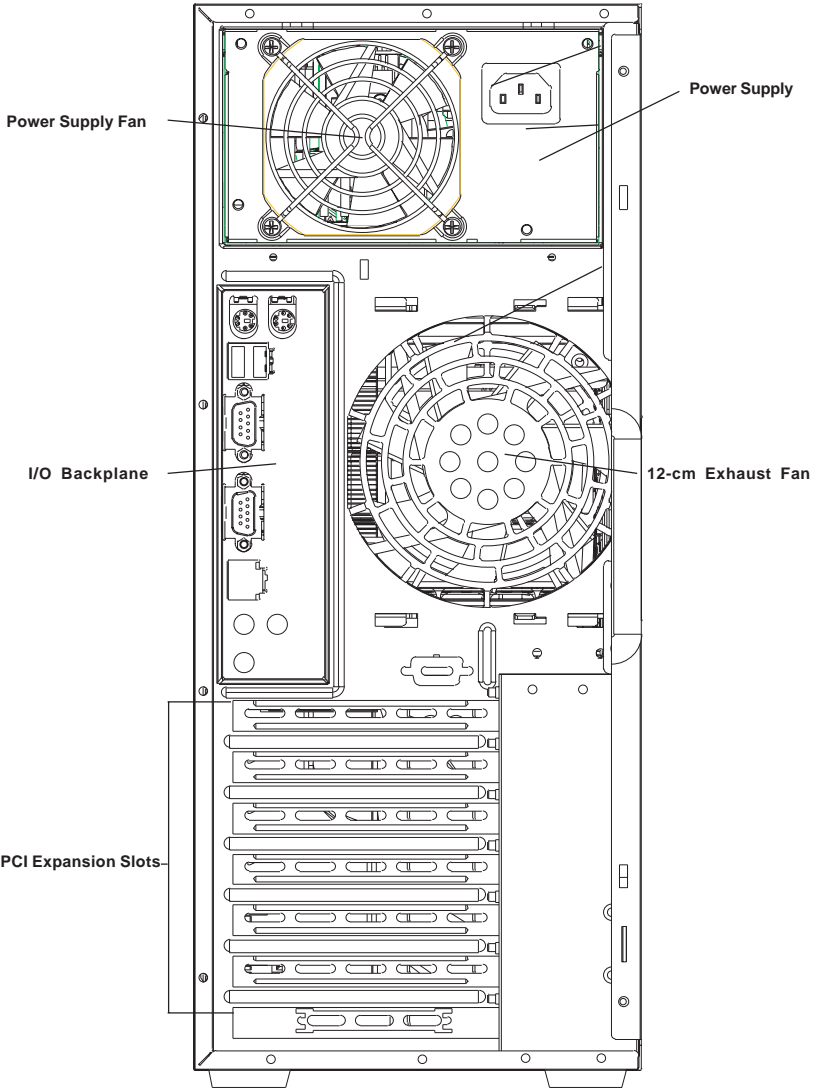

Figure 6-3. Chassis Rear View



6-3 System Fans

A 9-cm fan at the front of the chassis provides cool air intake while a 12-cm exhaust fan at the rear of the chassis pulls the cool air through the system and expels the hot air. Both fans feature PWM (Pulse Width Modulation) technology, which enables fans to adjust their speed according to the heat level sensed in the system. This results in more efficient and quieter fan operation. Fan speed is controlled by a setting in BIOS (see page 7-19).

Fan Failure

Under normal operation, the chassis, the exhaust and the power supply fans all run continuously. The system must be powered down before replacing either the 9-cm chassis fan or the 12-cm exhaust fan.

Replacing System Fans

1. Identifying and accessing the failed fan

Inspect the back of the chassis to determine if the 12-cm exhaust fan has failed or the lower front section of the chassis to check if the 9-cm fan has failed. Power down the system and remove the left chassis cover by first removing the two screws from the back lip of the cover. Push the cover toward the rear of the chassis until it stops (after moving about ½ inch). Then lift the cover out and away from the chassis.

2. Removing the 12-cm fan

Unplug the fan wires from the header on the motherboard. The fan housing has two long tabs that protrude through the back of the chassis. Push these two tabs inward and lift the housing to remove it from its locked position, then lift the housing out of the chassis (see Figure 6-4).

3. Removing the 9-cm fan

Unplug the fan wires from the header on the motherboard. The housing for the 9-cm fan is attached to the chassis with a single screw. Remove this screw and lift the housing out of the chassis (see Figure 6-5).

4. Installing a new system fan

Disassemble the housing and replace the failed fan with an identical one (available from Supermicro). After the new fan has been installed, reassemble the fan housing and install it by reversing the removal procedure. Plug the fan wires back into their header on the motherboard. Finish by replacing the chassis cover, then restore power to the system. Verify that the replaced fan is working properly.

Figure 6-4. Removing the 12-cm Exhaust Fan

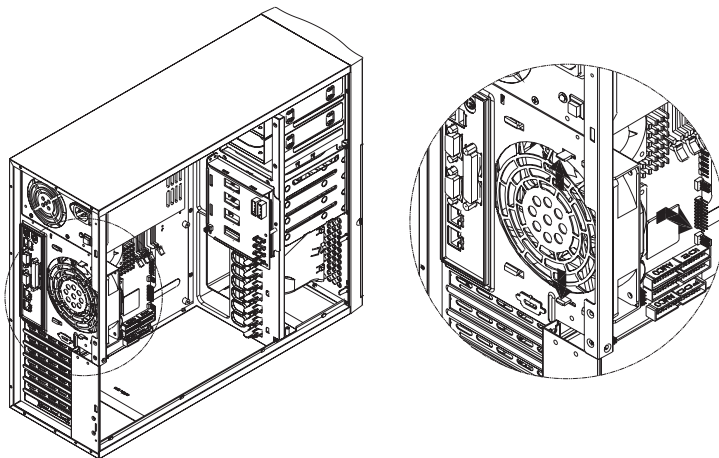
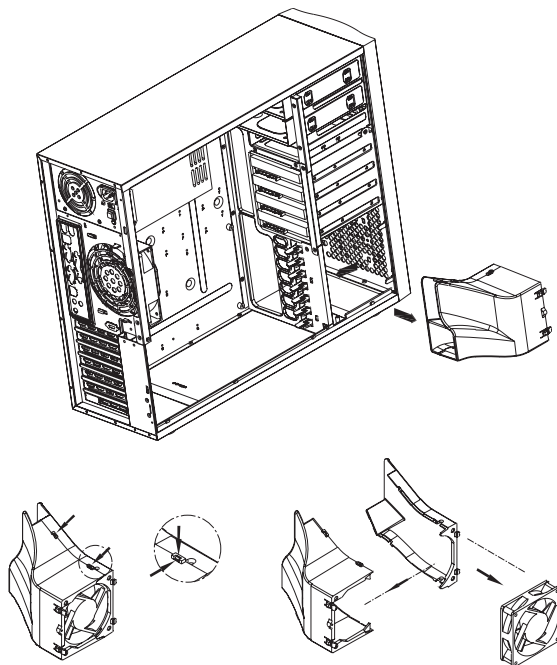

Figure 6-5. Removing the 9-cm Chassis Fan



6-4 Drive Bay Installation

7034A-T: A swinging bezel covers the front of the chassis but does not need to be removed to access the drives. To access the SATA drives, simply unlock the bezel and swing it open.

7034A-i: The bezel that covers the front of the chassis must be removed to access the drives. To remove the bezel, push on the three tabs on the inside left side lip of the front chassis cover. Then slightly swing out the same (left) side of the cover - about ½ inch only. Remove by pushing on the open side of the cover to remove it from the chassis (do not try to swing or pull it straight out after opening the left side).

Serial ATA Drives (7034A-T only)

After unlocking the Serial ATA (SATA) drive bay door, swing it open to access the SATA drives. The drive IDs are preconfigured as 0 through 3 in order from bottom to top.

Important!



Use extreme caution when working around the SATA backplane. Do not touch the backplane with any metal objects and make sure no ribbon cables touch the backplane or obstruct the airflow holes in the SATA backplane. Regardless of how many SATA hard drives are installed, all four SATA drive carriers must remain in the drive bays to promote proper airflow.

1. Installing/removing hot-plug SATA drives:

The four SATA drive carriers are all easily accessible at the front of the chassis. The SATA drives are hot-swappable, meaning they can be removed and installed without powering down the system. To remove a drive carrier, first open the front bezel then push the release button located beside the drive LEDs. Swing the colored handle fully out and use it to pull the unit straight out (see Figure 6-6).

Note: Your operating system must have RAID support to enable the hot-plug capability of the SATA drives.

2. Mounting a SATA drive in a drive carrier:

The SATA drives are mounted in drive carriers to simplify their installation and removal from the chassis. These carriers also work to promote proper airflow for the system. For this reason, even carriers without SATA drives must remain in the server. If you need to add a new SATA drive, insert the drive into the carrier with the printed circuit board side facing down so that the mounting holes align with those in the carrier. Secure the drive to the carrier with four screws.

Figure 6-6. Removing an SATA Drive Carrier

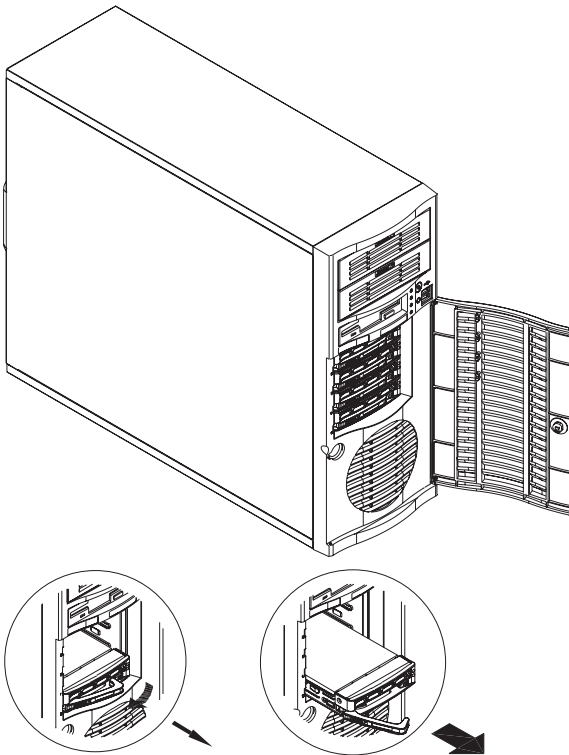

3. SATA backplane:

All four SATA drives plug into the SATA backplane. There are two jumpers and two headers on the SATA backplane, as noted below. A ribbon cable from JA1 on the serverboard should be connected to the JP26 connector on the SATA backplane. There are also two power connectors on the backplane - both should be connected. See Figure 6-7 for the locations of backplane connectors - the reverse side of the backplane has four channel connectors that the SATA drives plug into when inserted with a SATA drive carrier. You cannot cascade the SATA backplane.

Jumper	Description	Setting
JP18	Buzzer Reset	Alarm Reset Header
JP25	OH Temperature	Open: 45 degrees C Pins 1-2: 50 degrees C (default) Pins 2-3: 55 degrees C
JP26	SATA Drive Activity	Drive Activity
JP28	Fan Sense	Pins 1-2: Enable Pins 2-3: Disable (default)

Figure 6-7. SATA733 Backplane

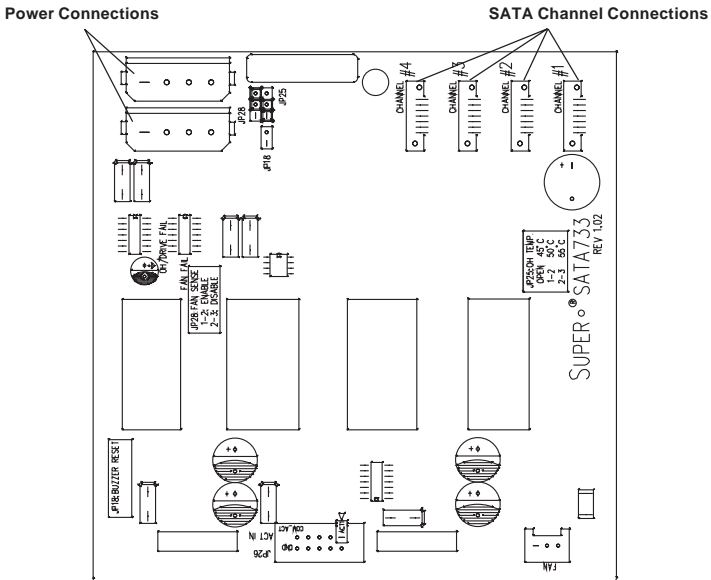

Installing Components in the 5.25" Drive Bays

1. Drive bay configuration

The 7034A-T/7034A-i has two empty 5.25" drive bays above the SATA/IDE drive bays. Components such as a floppy drive, IDE hard drives or CD-ROM drives can be installed in these 5.25" drive bays.

2. Mounting components in the drive bays

First power down the system and then remove the top/left chassis cover to access the drive components. With the cover off, remove the two or four screws that secure the drive carrier to the chassis (one side only) then push the entire empty drive carrier out from the back.

Adding a CD-ROM drive: remove the guide plate from right side of the empty drive carrier and screw it into the right side of the CD-ROM drive using the holes provided (see Figure 6-8). Then slide the CD-ROM into the bay and secure it to the chassis with the drive carrier screws you first removed. Attach the power and data cables to the drive. Replace the top/left chassis cover before restoring power to the system.

Adding an IDE or floppy drive: to add one of these drives, install it into one of the removed empty drive carriers with the printed circuit board side toward the carrier so that the drive's mounting holes align with those in the carrier. Secure the drive to the carrier with four screws then slide the assembly into the bay and secure it to the chassis with the drive carrier screws you first removed. Attach the power and data cables to the drive. Replace the top/left chassis cover before restoring power to the system.

Note: A red wire typically designates the location of pin 1. You should keep the drive carriers inserted in any unused drive bays to reduce EMI and noise and to facilitate the airflow inside the chassis.

Figure 6-8. Adding a Component Without a Drive Carrier

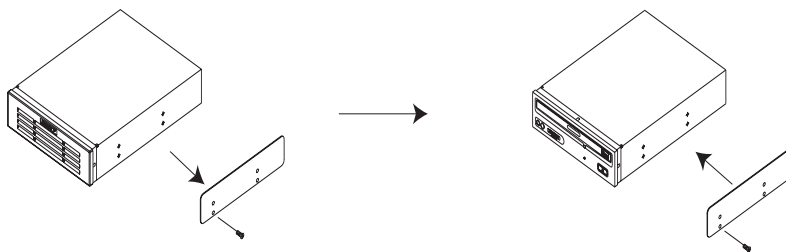

6-5 Power Supply

The 7034A-T/7034A-i has a single 645W redundant cooling power supply (part# PWS-0060) that features noise-suppression technology for silent operation. The power supply has the capability to automatically sense and operate at 100 - 240V AC. This power supply also has PFC (Power Factor Correction) built in.

Power Supply Failure

If the power supply unit fails, the system will shut down and you will need to replace the power supply unit. Replacement units can be ordered directly from Supermicro (see contact information in Chapter 1).

Replacing the Power Supply

1. Accessing the power supply:

After powering down the system, you'll need to remove the left chassis cover to access the power supply for removal.

2. Removing the power supply:

First, unplug the power cord from the power supply. Then remove the power supply connectors going to the serverboard (ATX PWR, PWR2 and PWR3). Finally, remove the screws that secure the unit to the mounting brackets in the chassis and then pull the unit completely out.

3. Installing a new power supply module:

Replace the failed unit with another unit having the exact same part number. Gently but firmly push the new unit all the way into the open bay. Secure it to the mounting brackets in the chassis with the screws provided. Connect the three power cables to the serverboard (ATX PWR, PWR2 and PWR3 connectors). Finish by replacing the chassis left cover and then restoring power to the system.

Notes

Chapter 7

BIOS

7-1 Introduction

This chapter describes the AMIBIOS for the X6DAL-TG/X6DAL-G. The AMI ROM BIOS is stored in a Flash EEPROM and can be easily upgraded using a floppy disk-based program. This chapter describes the basic navigation of the AMI BIOS Setup Utility setup screens.

Starting the BIOS Setup Utility

To enter the AMI BIOS Setup Utility screens, hit the <Delete> key while the system is booting-up.

Note: In most cases, the <Delete> key is used to invoke the AMI BIOS setup screen. There are a few cases when other keys are used, such as <F1>, <F2>, and so on.

Each main BIOS menu option is described in this user's guide. The Main BIOS setup menu screen has two main frames. The left frame displays all the options that can be configured. "Grayed-out" options cannot be configured. Options in blue can be configured by the user. The right frame displays the key legend. Above the key legend is an area reserved for a text message. When an option is selected in the left frame, it is highlighted in white. Often a text message will accompany it. (Note: The AMI BIOS has default text messages built in. Supermicro retains the option to include, omit, or change any of these text messages.)

The AMI BIOS setup/utility uses a key-based navigation system called hot keys. Most of the AMI BIOS setup utility hot keys can be used at any time during the setup navigation process. These keys include <F1>, <F10>, <Enter>, <ESC>, <Arrow> keys, and so on.

Note: Options printed in **Bold** are the default settings.

Note: fan speed is controlled by the "System Fan Monitor" setting in BIOS. The recommended setting for the 7034A-T/7034A-i is "4-pin (Workstation)". If you load the BIOS default settings this setting may change. Therefore, if you do load BIOS defaults, you should reenter BIOS setup and change this setting back to "**4-pin (Workstation)**", then save and exit (see page 7-19).

7-2 Main Setup

When you first enter the AMI BIOS Setup Utility, you will enter the Main setup screen. You can always return to the Main setup screen by selecting the **Main** tab on the top of the screen. The Main BIOS Setup screen is shown below.

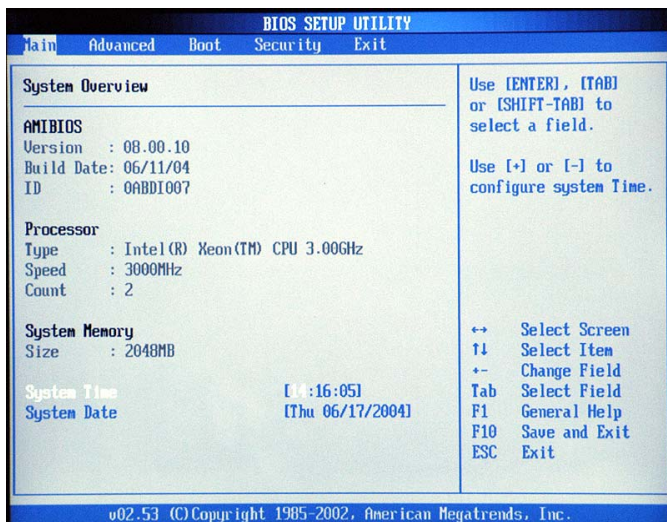

When you select the Main Setup, the following items will be automatically displayed:

System Overview: The following BIOS information will be displayed:

AMI BIOS

Version
Built Date
ID

Processors

When you select this option, the AMI BIOS will automatically display the status of processors as shown in the screen below:

Type
Speed
Count

System Memory

This option allows the AMI BIOS to display the status of memory installed in the system.

Size

This option allows the AMI BIOS to display the size of memory installed in the system.

System Time/System Date

Use this option to change the system time and date. Highlight *System Time* or *System Date* using the <Arrow> keys. Enter new values through the keyboard. Press the <Tab> key or the <Arrow> keys to move between fields. The date must be entered in DAY/MM/DD/YY format. The time is entered in HH:MM:SS format. (***Note:** The time is in 24-hour format. For example, 5:30 A.M. appears as 05:30:00, and 5:30P.M. as 17:30:00.)

7-3 Advanced Settings

The Advanced Settings screen and sub menus are listed below:

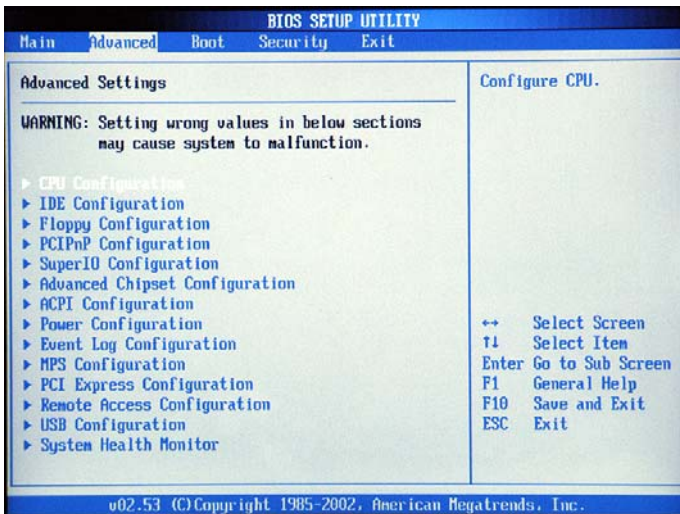

Warning

When you first enter the Advanced Setup screen, the Setup Warning will be displayed. Please follow the instruction and set the correct value for each item to prevent the system from malfunctioning.

►CPU Configuration Sub Menu

Configure Advanced CPU Settings

This option allows the user to configure Advanced CPU settings for the processor(s) installed in the system.

Ratio CMOS Setting

This option allows the user to set the ratio between the CPU Core Clock and the FSB Frequency. (*Note: if an invalid ratio is entered, AMIBIOS will restore the setting to the previous state.)

VID CMOS Setting

This option sets the VID setting for the processor(s).

Max CPUID Value Limit

This feature allows the user to set the maximum CPU ID value. Enable this function to boot legacy OS that cannot support processors with extended CPUID functions. The options are Enabled, and **Disabled**.

Hyper-Threading

This setting allows you to **Enable** or Disable the function of hyper-threading. Enabling hyper-threading results in increased CPU performance.

► IDE Configuration Sub Menu

The screen for the Primary IDE Master is shown below:

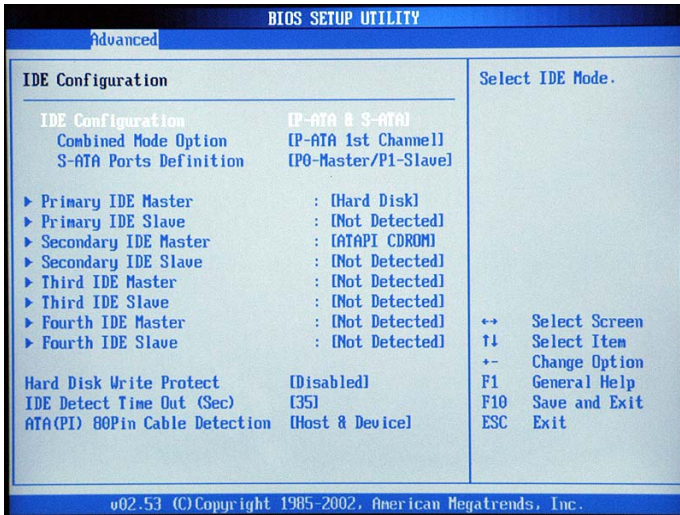

When you select this Sub Menu, the AMI BIOS automatically displays the status of the following items:

Onboard PCI IDE Operate Mode

This feature allows the user to set the Onboard PCI IDE Operation Mode. The options are: Native Mode and **Legacy Mode**. (*Please refer to Addendum D for information on Legacy Mode and Native Mode.)

IDE Configuration

This feature allows the user to set the IDE mode. The options are: Disabled, P-ATA (Parallel ATA) Only, S-ATA (Serial ATA) Only, and **P-ATA & S-ATA**. (*Please refer to Addendum D for Parallel ATA and Serial ATA information.)

P-ATA & S-ATA

Combined Mode Operation

This feature allows the user to select the IDE Combined Mode. The options are: Disabled, P-ATA (Parallel ATA) 1ST Channel and **S-ATA (Serial ATA 1st Channel)**.

S-ATA Ports Definition

This feature allows the user to configure Serial ATA Ports. The options are: **P0-Master/P1-Slave**, P0-Slave/P1-Master.

P-ATA Only

S-ATA Running Enhanced Mode

Select Yes if you want the function of Serial ATA Enhanced Mode to be enabled at all times. Options are **Yes** and **No**.

P-ATA Channel Selection

This feature allows the user to select which channel to set the Parallel ATA Mode. The options are: Primary, Secondary or **Both**.

S-ATA Ports Definition

This feature allows the user to configure Serial ATA Ports. The options are: **P0-3rd/P1-4th**, P0-4th/P1-3rd.

Configuring S-ATA as RAID

Select Yes to configure Serial ATA as RAID. The options are **Yes**, and **No**.

S-ATA Only

S-ATA Ports Definition

This feature allows the user to configure Serial ATA Ports. The options are: **P0-1st/P1-2nd**, P0-2nd/P1-1st.

Primary IDE Master/Slave, Secondary IDE Master/Slave, Third IDE Master/Slave, Fourth IDE Master/Slave Sub Menu

From the Advanced Setup screen, press <Enter> to access this sub menu for the primary, secondary, third and fourth IDE master and slave drives. Use this screen to select options for the Primary and Secondary IDE drives. Use the up and down <Arrow> keys to select an item. Use the <Plus> and <Minus> keys to change the value of the selected option.

Type

Select the type of device connected to the system. The options are Not Installed, **Auto**, CDROM and ARMD.

LBA/Large Mode

LBA (Logical Block Addressing) is a method of addressing data on a disk drive. In the LBA mode, the maximum drive capacity is 137 GB. For drive capacities over 137 GB, your system must be equipped with 48-bit LBA mode addressing. If not, contact your manufacturer or install an ATA/133 IDE controller card that supports 48-bit LBA mode. The options are Disabled or **Auto**.

Block (Multi-Sector Transfer)

Block mode boosts IDE drive performance by increasing the amount of data transferred. Only 512 bytes of data can be transferred per interrupt if block mode is not used. Block mode allows transfers of up to 64 KB per interrupt. Select "Disabled" to allow the data to be transferred from and to the device one sector at a time. Select "Auto" to allow the data transfer from and to the device occur multiple sectors at a time if the device supports it. The options are **Auto** and Disabled.

PIO Mode

IDE PIO (Programmable I/O) mode programs timing cycles between the IDE drive and the programmable IDE controller. As the PIO mode increases, the cycle time decreases. The options are **Auto**, 0, 1, 2, 3, and 4" Select Auto to allow the AMI BIOS to auto detect the PIO mode. Use this value if the IDE disk drive support cannot be determined. Select 0 to allow the AMI BIOS to use PIO mode 0. It has a data transfer rate of 3.3 MBs. Select 1 to allow the AMI BIOS to use PIO mode 1. It has a data transfer rate of 5.2 MBs. Select 2 to allow the AMI BIOS to use PIO mode 2. It has a data transfer rate of 8.3 MBs. Select 3 to allow the AMI BIOS to use PIO mode 3. It has a data transfer rate of 11.1 MBs. Select 4 to allow the AMI BIOS to use PIO mode 4. It has a data transfer rate of 16.6 MBs. This setting generally works with all hard disk drives manufactured after 1999. For other disk drives, such as IDE CD-ROM drives, check the specifications of the drive.

DMA Mode

Select Auto to allow the BIOS to auto detect the DMA mode. Use this value if the IDE disk drive support cannot be determined. Select SWDMA0

to allow the BIOS to use Single Word DMA mode 0. It has a data transfer rate of 2.1 MBs. Select SWDMA1 to allow the BIOS to use Single Word DMA mode 1. It has a data transfer rate of 4.2 MBs. Select SWDMA2 to allow the BIOS to use Single Word DMA mode 2. It has a data transfer rate of 8.3 MBs. Select MWDMA0 to allow the BIOS to use Multi Word DMA mode 0. It has a data transfer rate of 4.2 MBs. Select MWDMA1 to allow the BIOS to use Multi Word DMA mode 1. It has a data transfer rate of 13.3 MBs. Select MWDMA2 to allow the BIOS to use Multi-Word DMA mode 2. It has a data transfer rate of 16.6 MBs. Select UDMA0 to allow the BIOS to use Ultra DMA mode 0. It has a data transfer rate of 16.6 MBs. It has the same transfer rate as PIO mode 4 and Multi Word DMA mode 2. Select UDMA1 to allow the BIOS to use Ultra DMA mode 1. It has a data transfer rate of 25 MBs. Select UDMA2 to allow the BIOS to use Ultra DMA mode 2. It has a data transfer rate of 33.3 MBs. Select UDMA3 to allow the BIOS to use Ultra DMA mode 3. It has a data transfer rate of 66.6 MBs. Select UDMA4 to allow the BIOS to use Ultra DMA mode 4 . It has a data transfer rate of 100 MBs. The options are **Auto**, SWDMA_n, MWDMA_n, and UDMA_n.

S.M.A.R.T. For Hard disk drives

Self-Monitoring Analysis and Reporting Technology (SMART) can help predict impending drive failures. Select "Auto" to allow the BIOS to auto detect hard disk drive support. Select "Disabled" to prevent the AMI BIOS from using the S.M.A.R.T. Select "Enabled" to allow the AMI BIOS to use the S.M.A.R.T. to support hard drive disk. The options are Disabled, Enabled, and **Auto**.

32Bit Data Transfer

Select "Enabled" to activate the function of 32-Bit data transfer. Select "Disabled" to deactivate the function. The options are Enabled and **Disabled**.

Hard Disk Write Protect

Select Enabled to enable the function of Hard Disk Write Protect to prevent data from being written to HDD. The options are Enabled or **Disabled**.

IDE Detect Time Out

This feature allows the user to set the time-out value for detecting ATA, ATA PI devices installed in the system. The options are 0 (sec), 5, Mode 1.0, 15, 20, 25, 30, and **35**.

ATA(PI) 80Pin Cable Detection

This feature allows the AMI BIOS to auto-detect 80Pin ATA(PI) Cable. The options are: **Host & Device**, Host and Device.

►Floppy Configuration

This option allows the user to configure the settings for the Floppy Drives installed in the system.

Floppy A

Move the cursor to these fields via up and down <arrow> keys to select the floppy type. The options are Disabled, 360 KB 5 1/4", 1.2 MB 5 1/4", 720 KB 3 1/2", 1.44 MB 3 1/2", and 2.88 MB 3 1/2". Default setting for Floppy A drive is **1.44 MB 3 1/2"**.

OnBoard Floppy Controller

Select "Enabled" to enable the Onboard Floppy Controller. The options are "Disabled", and "**Enabled.**"

► PCI/PnP Configuration

This feature allows the user to set PCI/PnP configurations for the following items:

Plug & Play OS

Select Yes to allow the OS to configure Plug & Play devices. (*This is not required for system boot if you system has an OS that supports Plug & Play.) Select No to allow the AMIBIOS to configure all devices in the system.

PCI Latency Timer

This option sets the latency of all PCI devices on the PCI bus. Select "32" to set the PCI latency to 32 PCI clock cycles. Select "64" to set the PCI latency to 64 PCI clock cycles. Select "96" to set the PCI latency to 96 PCI clock cycles. Select "128" to set the PCI latency to 128 PCI clock cycles. Select "160" to set the PCI latency to 160 PCI clock cycles. Select "192" to set the PCI latency to 192 PCI clock cycles. Select "224" to set the PCI latency to 224 PCI clock cycles. Select "248" to set the PCI latency to 248 PCI clock cycles.

Allocate IRQ to PCI VGA

Set this value to allow or restrict the system from giving the VGA adapter card an interrupt address. The options are **Yes** and No.

Palette Snooping

Select Enabled to inform the PCI devices that an ISA graphics device is installed in the system in order for the graphics card to function properly. The options are Enabled or **Disabled**.

PCI IDE BusMaster

Set this value to allow or prevent the use of PCI IDE busmastering. Select "Enabled" to allow the AMI BIOS to use PCI busmaster for reading and writing to IDE drives. The options are "**Disabled**" and "Enabled".

Offboard PCI/ISA IDE Card

This option allows the user to assign a PCI slot number to an Off-board PCI/ISA IDE card in order for it to function properly. The options are: **Auto**, PCI Slot1, PCI Slot2, PCI Slot3, PCI Slot4, PCI Slot5, and PCI Slot6.

IRQ3/IRQ4/IRQ5/IRQ7/IRQ9/IRQ10/IRQ11/IRQ14

This feature specifies the availability of an IRQ to be used by a PCI, PnP device. Select Reserved for the IRQ to be used by a Legacy ISA device. The options are: **Available**, Reserved.

DMA Channel 0/DMA Channel 1/DMA Channel 3/DMA Channel 5/ DMA Channel 6/DMA Channel 7

Select **Available** to indicate that a specific DMA channel is available to be used by a PCI/PnP device. Select Reserved, if the DMA channel specified is reserved for a Legacy ISA device.

Reserved Memory Size

This feature specifies the size of memory block to be reserved for Legacy ISA devices. The options are: **Disabled**, 16K, 32K, 64K.

► Super IO Configuration Sub Menu

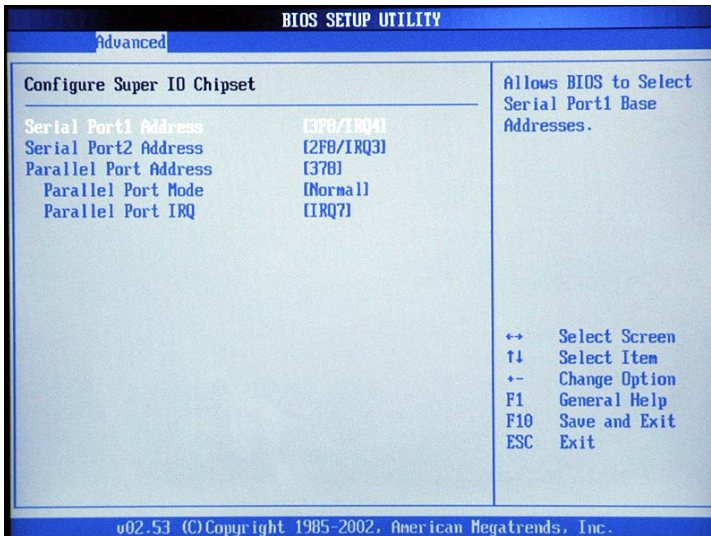

Serial Port1 Address

This option specifies the base I/O port address and Interrupt Request address of serial port 1. Select "Disabled" to prevent the serial port from accessing any system resources. When this option is set to *Disabled*, the serial port physically becomes unavailable. Select "3F8/IRQ4" to allow the serial port to use 3F8 as its I/O port address and IRQ 4 for the interrupt address. The options are Disabled, **3F8/IRQ4**, 3E8/IRQ4, 2E8/IRQ3.

Serial Port2 Address

This option specifies the base I/O port address and Interrupt Request address of serial port 2. Select "Disabled" to prevent the serial port from accessing any system resources. When this option is set to "Disabled", the serial port physically becomes unavailable. Select "2F8/IRQ3" to allow the serial port to use 2F8 as its I/O port address and IRQ 3 for the interrupt address. The options are Disabled, **2F8/IRQ3**, 3E8/IRQ4, 2E8/IRQ3.

Parallel Port Address

This option specifies the I/O address used by the parallel port. Select Disabled to prevent the parallel port from accessing any system resources. When the value of this option is set to Disabled, the printer port becomes unavailable. Select **378** to allow the parallel port to use 378 as its I/O port address. The majority of parallel ports on computer systems use IRQ7 and I/O Port 378H as the standard setting. Select 278 to allow the parallel port to use 278 as its I/O port address. Select 3BC to allow the parallel port to use 3BC as its I/O port address.

Parallel Port Mode

Specify the parallel port mode. The options are **Normal**, Bi-directional, EPP and ECP.

Parallel Port IRQ

Select the IRQ (interrupt request) for the parallel port. The options are IRQ5 and **IRQ7**.

►Advanced Chipset Settings

This item allows the user to configure the Advanced Chipset settings for the system.

►NorthBridge Configuration

This feature allows the user to configure the settings for Intel Lindenhurst NorthBridge chipset.

Memory Remap Feature

Select Enabled to allow remapping of overlapped PCI memory above the total physical memory. The options are **Enabled** and Disabled.

Memory Mirroring and Sparing

Select Enabled to enable Memory RAS (-Mirroring and Sparing) to allow the system to create a mirror copy of data written to the memory for data security. The options are **Disabled** and Enabled.

►SouthBridge Configuration

This feature allows the user to configure the settings for Intel ICH SouthBridge chipset.

CPU B.I.S.T. Enable

Select Enabled to enable the function of CPU Built In Self Test. The options are Enabled and **Disabled**.

ICH Delayed Transaction

Select Enabled to enable the function of ICH Delayed Transaction to provide back-compatibility for slower components . The options are **Enabled** and Disabled.

ICH DCB Enable

Select Enabled to enable ICH DMA Collection Buffer. The options are **Enabled** and Disabled.

Onboard AC' 97 Audio

Select Auto to enable the function of Onboard AC'97 automatically. The options are **Auto**, Enabled and Disabled.

►ACPI Configuration

This item allows the user to enable or disable ACPI support for the operating system.

General ACPI Configuration

Use this feature to configure additional ACPI options. Select "Yes" if the operating system supports ACPI. Select No if the operating system does not support ACPI. The options are No and **Yes**.

Suspend Mode

This feature allows the user to select the ACPI state when the system is on the Suspend Mode. Select S1 if you want the system to standby. Select S3 to enable the function of Suspend to RAM, which will shorten bootup time after poweroff. The options are **S1(POS)** and S1&S3 (STR).

Advanced ACPI Configuration

Use this feature to configure additional ACPI options. Select "Yes" if the operating system supports ACPI. Select No if the operating system does not support ACPI. The options are No and **Yes**.

ACPI 2.0 Features

Select Yes to allow RSDP pointers to point to the 64-bit Fixed System Description Tables. Select No to deactivate this function. The options are Yes and **No**.

ACPI APIC Support

Select Enabled to allow the ACPI APIC Table Pointer to be included in the RSDP pointer list. The options are **Enabled**, and Disabled.

AMI OEMB Table

Select Enabled to allow the OEMB Table Pointer to be included in the R(x)SDT pointer lists. The options are **Enabled**, and Disabled.

Headless Mode

Select Enabled to activate the Headless Operation Mode through ACPI, which will allow the system to boot up and function properly without keyboard and monitor display. The options are Enabled, and **Disabled**.

► Power Configuration

This feature allows the user to configure PnP settings.

Power Button Mode

This setting allows you to decide if the power button will go into the On/Off mode or the Suspend mode if it is pressed. The options are **On/Off** and **Suspend**.

Restore on AC Power Loss

This setting allows you to choose how the system will react when power returns after an unexpected loss of power. The options are **Power Off**, **Power On** and **Last State**.

Watch Dog Timer

This setting is used to enable or disabled the Watch Dog Timer function. It must be used in conjunction with the WD jumper (see Chapter 2 for details). The options are **Enabled** and **Disabled**.

► Event Log Configuration

Highlight this item and press <Enter> to view the contents of the event log.

View Event Log

This feature allows the user to view all unread events.

Mark All Events as Read

Highlight this item and press <Enter> to mark the DMI events as read.

Clear Event Logs

This setting will clear all event logs when set to "OK". The options are "OK" and "**Cancel**".

ECC Event Logging

This setting allows you to enable or disable ECC Event logging. The options are **Enabled** or **Disabled**.

Hub Interface Event Logging

This setting allows you to enable or disable Hub Interface Event logging. The options are **Enabled** or **Disabled**.

System Bus Event Logging

This setting allows you to enable or disable System Bus Event logging. The options are **Enabled** or **Disabled**.

Memory Buffer Event Logging

This setting allows you to enable or disable Memory Buffer Event logging. The options are Enabled or **Disabled**.

PCI Error Logging

This setting allows you to enable or disable PCI Error logging. The options are Enabled or **Disabled**.

PCI Express Error Logging

This setting allows you to enable or disable PCI Express Error logging. The options are Enabled or **Disabled**.

►MPS Configuration

This section allows the user to configure the multi-processor table.

MPS Revision

This feature allows the user to select MPS Revision. The options are 1.1 or 1.4.

►PCI Express Configuration

This section allows the user to configure PCI Express slots.

Active State Power Management

Select Enabled to activate the function of power management for signal transactions between PCI Express L0 and L1 Link. The options are Enabled and **Disabled**.

I/O Expander Mode

This feature allows the user to set the IO Expand Mode for Hot Plug support. The options are **PCA9555**, Two PCA9554, One PCA9554 (Low), One PCA9554 (High), Two PCA9554A, One PCA9554A (Low), and One PCA9554 (High).

PCI Express Port2 (Slot 1)

This feature allows the user to configure the PCI Express slot. The options are Auto, **Enabled**, and Disabled.

PCI Express Port4 (Slot 6)

This feature allows the user to configure the PCI Express slot. The options are Auto, **Enabled**, and Disabled.

PCI Express Compliance Mode

Select Enabled to enable MCH to activate PCI Express Compliance Mode. The options are **Disabled** and Enabled.

Spread Spectrum

Select Enabled to enable Spread Spectrum. The options are **Disabled** and Enabled.

► Remote Access Configuration

You can use this screen to select options for the Remote Access Configuration. Use the up and down <Arrow> keys to select an item. Use the <Plus> and <Minus> keys to change the value of the selected option.

Remote Access

This feature allows the user to disable the function of Remote Access. If Disabled is not select, then you can select a Remote Access type. The options are Enabled or **Disabled**.

► USB Configuration

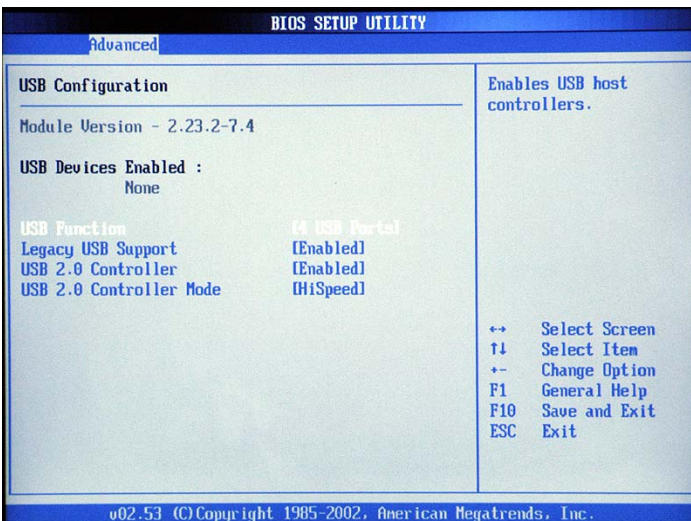

USB Function

This feature allows you to enable 2 USB Ports or 4 USB Ports. The options are Disabled, 2 USB Ports, and **4 USB Ports**.

Legacy USB Support

Select "Enabled" to enable the support for USB Legacy. Disable legacy support if there are no USB devices installed in the system. The options are Disabled, **Enabled** and Auto.

USB 2.0 Controller

This setting allows you to enable or disable USB 2.0 Controller. The options are Disabled or **Enabled**.

USB 2.0 Controller Mode

This setting allows you to configure USB 2.0 Controller Mode. The options are **Hi-Speed (480 Mbps)** or Full Speed-12Mbps.

► **System Health Monitor**

This feature allows the AMI BIOS to automatically display the status of the following items:

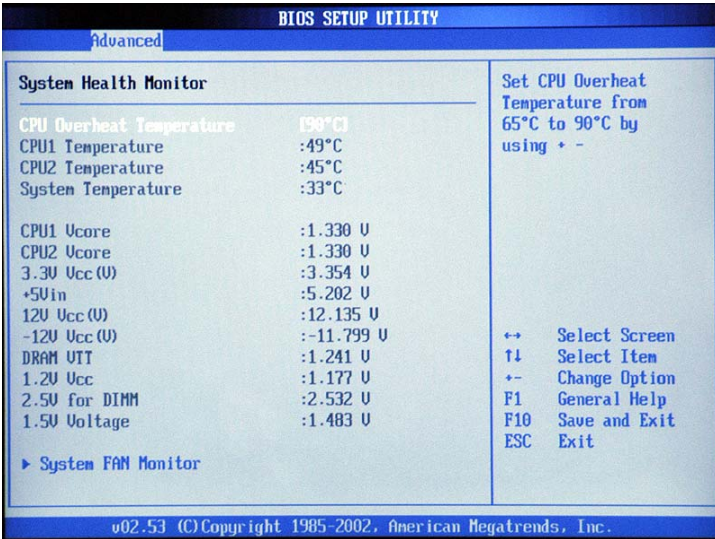

System Health Function

Select "Enabled" to enable the function of Hardware Health Monitoring Device. The options are "Enabled" and "Disabled".

CPU Temperature

The feature allows the user to set the CPU temperature threshold. The options range from 65°C to 90°C. The default setting is 78°C.

If the System Health Function is enabled, the BIOS will automatically display the status of the following items:

CPU1 Temperature, CPU2 Temperature, System Temperature

The AMI BIOS will automatically display the following information: CPU1 VCORE/CPU2 VCORE (for 2U systems), 3.3V Vcc(V), +5 Vin, 12V Vcc(V), -12V Vcc (V), DRAM VTT, 1.2V Vcc, 2.5V for DIMM, 1.5V Standby Power

System Fan Monitor

This feature allows the user to decide how the system controls the speed of the onboard fans. If the option is set to “3-pin fan”, the fan speed is controlled based upon the CPU die temperature. When the CPU die temperature is higher, the fan speed will be higher as well.

If the option is set to “4-pin”, BIOS will employ PWM (Pulse Width Modulation) to control fan speed according to the Thermal Management Settings, which may be pre-configured by the user.

Select “3-pin” if your serverboard has 3-pin fan headers. Select “4-pin” if your serverboard has 4-pin fan headers. Select “Workstation” if your system is used as a workstation. Select “Server” if your system is used as a server. Select “Disable” to disable the fan speed control function and allow the onboard fans to run at full speed (12V) at all time. BIOS will apply the chosen setting to all fan headers on the serverboard.

The options are "Disable", "3-pin (Server)", "3-pin (Workstation)", "4-pin (Server)" and "4-pin (Workstation)".

The recommended setting for the 7034A-T/7034A-i is "4-pin (Workstation)".

Note: loading the default settings into BIOS may change this setting. If you do load BIOS defaults, you should reenter BIOS setup and change this setting back to "**4-pin (Workstation)**", then save and exit.

► Boot Settings Configuration

This item allows the user to configure the boot settings for the system.

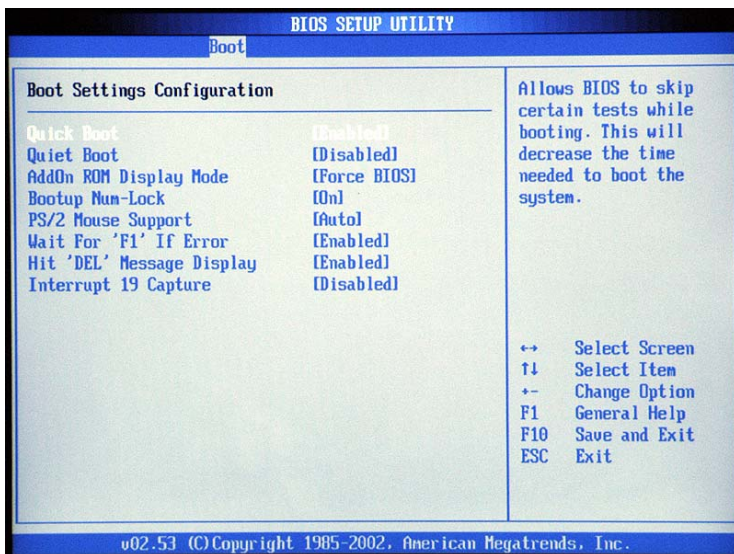

Quick Boot

Select Enabled to allow the AMI BIOS to skip certain tests during POST in order to shorten the time needed for the system to bootup. The options are **Enabled**, and Disabled.

Quiet Boot

Set this value to allow the boot up screen options to be modified between POST messages or OEM logo. The default setting is **Enabled**. Select Disabled to allow the computer system to display the POST messages. Select Enabled to allow the computer system to display the OEM logo.

Add-On ROM Display Mode

Set this option to display add-on ROM (read-only memory) messages. The default setting is **Force BIOS**. Select "Force BIOS" to allow the computer system to force a third party BIOS to display during system boot. Select "Keep Current" to allow the computer system to display the BIOS information during system boot. The options are Force BIOS and Keep Current.

Boot up Num-Lock

Set this value to allow the Number Lock setting to be modified during boot up. The default setting is **On**. The options are On and Off.

PS/2 Mouse Support

Set this value to allow the PS/2 mouse support to be modified. The options are **Auto**, Enabled and Disabled.

Wait for 'F1' If Error

Select Enable to activate the function of Wait for F1 if Error. The options are **Enabled** and Disabled.

Hit 'DEL' Message Display

Select Enabled to display Setup Message when the user hits the DEL key. The options are **Enabled** and Disabled.

Interrupt 19 Capture

Select Enabled to allow ROMs to trap Interrupt 19. The options are Enabled and **Disabled**.

► **Boot Device Priority**

This feature allows the user to specify the sequence of priority for the Boot Device.

The settings are "1st Floppy Drive", "CD ROM", "HDD", and "Disabled." The default settings are:

- 1st boot device – 1st Floppy Drive
- 2nd boot device – CD ROM
- 3rd boot device – HDD
- 4th boot device – IBA GE Slot 02180

► **Hard Disk Drives**

This feature allows the user to specify the Boot sequence from available Hard Drives.

1st Drive/2nd Drive

Specify the boot sequence for 1st Hard Drive. The options are HDD and Disabled.

► **Removable Drives**

This feature allows the user to specify the Boot sequence from available Removable Drives.

1st Drive

Specify the boot sequence for 1st Removable Drive. The options are **1st Floppy Drive** and Disabled.

► **CD/DVD Drives**

This feature allows the user to specify the boot sequence from available CDROM Drives.

1st Drive

Specify the boot sequence for 1st Hard Drive. The options are **CD ROM** and Disabled.

7-4 Security Settings

the AMI BIOS provides a Supervisor and a User password. If you use both passwords, the Supervisor password must be set first.

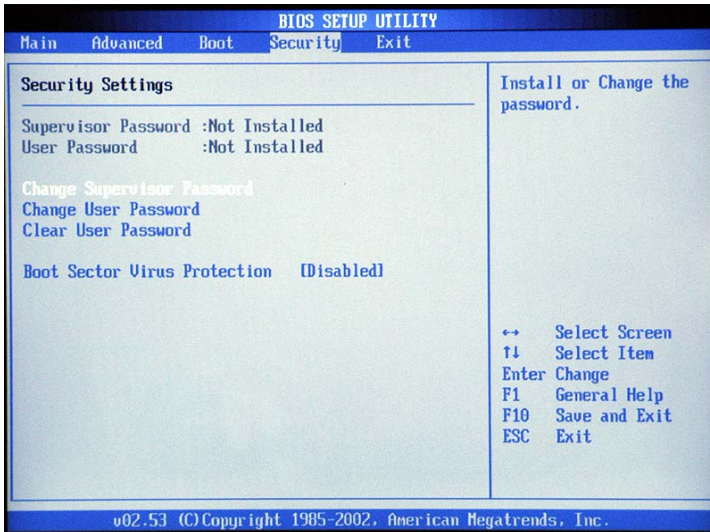

Change Supervisor Password

Select this option and press <Enter> to access the sub menu, and then, type in the password.

Change User Password

Select this option and press <Enter> to access the sub menu, and then, type in the password.

Clear User Password

Select this option and press <Enter> to access the sub menu. You can use the sub menu to clear the user password.

Boot Sector Virus Protection

This option is near the bottom of the Security Setup screen. Select "Disabled" to deactivate the Boot Sector Virus Protection. Select "Enabled" to enable boot sector protection. When "Enabled", the AMI BIOS displays a warning when any program (or virus) issues a Disk Format command or attempts to write to the boot sector of the hard disk drive. The options are "Enabled" and "Disabled".

7-5 Exit Options

Select the Exit tab from the AMI BIOS Setup Utility screen to enter the Exit the BIOS Setup screen.

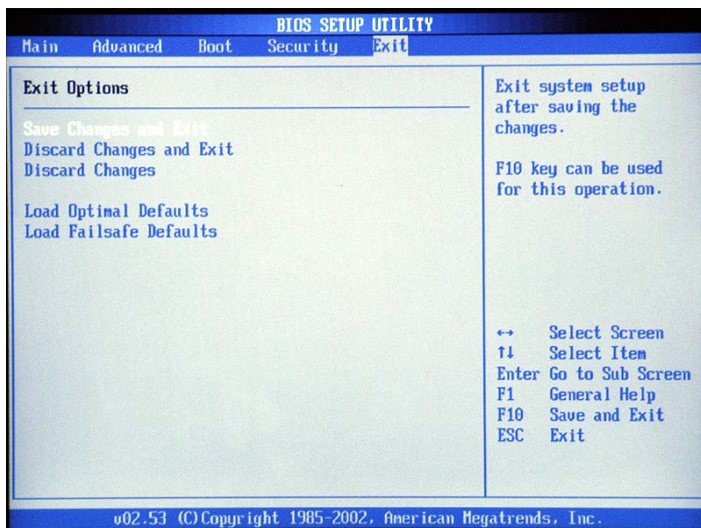

Saving Changes and Exit

When you have completed the system configuration changes, select this option to leave the BIOS Setup and reboot the computer, so the new system configuration parameters can take effect. Select Save Changes and Exit from the Exit menu and press <Enter>.

Discard Changes and Exit

Select this option to quit the BIOS Setup without making any permanent changes to the system configuration and reboot the computer. Select Discard Changes and Exit from the Exit menu and press <Enter>.

Discard Changes

Select this option and press <Enter> to discard all the changes and return to the AMI BIOS Utility Program.

Load Optimal Defaults

To set this feature, select Load Optimal Defaults from the Exit menu and press <Enter>. Then, Select "OK" to allow the BIOS to automatically load Optimal Defaults to the BIOS Settings. The Optimal settings are designed for maximum system performance, but may not work best for all computer applications.

Load Fail-Safe Defaults

To set this feature, select Load Fail-Safe Defaults from the Exit menu and press <Enter>. The Fail-Safe settings are designed for maximum system stability, but not maximum performance.

Notes

Appendix A

BIOS Error Beep/POST Codes

During the POST (Power-On Self-Test) routines, which are performed each time the system is powered on, errors may occur.

Non-fatal errors are those which, in most cases, allow the system to continue the boot-up process. The error messages normally appear on the screen.

Fatal errors are those which will not allow the system to continue the boot-up procedure. If a fatal error occurs, you should consult with your system manufacturer for possible repairs.

These fatal errors are usually communicated through a series of audible beeps. The numbers on the fatal error list, on the following page, correspond to the number of beeps for the corresponding error. All errors listed, with the exception of Beep Code 8, are fatal errors.

POST codes may be read on the debug LEDs (DS7 and DS8) located beside the LAN port on the motherboard backplane. See the description of the debug LEDs (LED1 and LED2) in Chapter 5.

A-1 AMIBIOS Error Beep Codes

Beep Code	Error Message	Description
1 beep	Refresh	Circuits have been reset. (Ready to power up.)
5 short, 1 long	Memory error	No memory detected in system
8 beeps	Display memory read/write error	Video adapter missing or with faulty memory

A-2 DS7/DS8 LED POST Codes

LED Indicators	Description/Message
DS7 DS8	
On On	PWR On
On Off	SPD Read OK
Off On	Memory Size-OK
Off Off	Starting Bus Initialization

Appendix B

BIOS POST Checkpoint Codes

When AMIBIOS performs the Power On Self Test, it writes checkpoint codes to I/O port 0080h. If the computer cannot complete the boot process, diagnostic equipment can be attached to the computer to read I/O port 0080h.

B-1 Uncompressed Initialization Codes

The uncompressed initialization checkpoint codes are listed in order of execution:

Checkpoint	Code	Description
-------------------	-------------	--------------------

D0h		The NMI is disabled. Power on delay is starting. Next, the initialization code checksum will be verified.
D1h		Initializing the DMA controller, performing the keyboard controller BAT test, starting memory refresh, and entering 4 GB flat mode next.
D3h		Starting memory sizing next.
D4h		Returning to real mode. Executing any OEM patches and setting the Stack next.
D5h		Passing control to the uncompressed code in shadow RAM at E000:0000h. The initialization code is copied to segment 0 and control will be transferred to segment 0.
D6h		Control is in segment 0. Next, checking if <Ctrl> <Home> was pressed and verifying the system BIOS checksum. If either <Ctrl> <Home> was pressed or the system BIOS checksum is bad, next will go to checkpoint code E0h. Otherwise, going to checkpoint code D7h.

B-2 Bootblock Recovery Codes

The bootblock recovery checkpoint codes are listed in order of execution:

Checkpoint	Code	Description
E0h		The onboard floppy controller if available is initialized. Next, beginning the base 512 KB memory test.
E1h		Initializing the interrupt vector table next.
E2h		Initializing the DMA and Interrupt controllers next.
E6h		Enabling the floppy drive controller and Timer IRQs. Enabling internal cache memory.
Edh		Initializing the floppy drive.
Eeh		Looking for a floppy diskette in drive A:. Reading the first sector of the diskette.
Efh		A read error occurred while reading the floppy drive in drive A:.
F0h		Next, searching for the AMIBOOT.ROM file in the root directory.
F1h		The AMIBOOT.ROM file is not in the root directory.
F2h		Next, reading and analyzing the floppy diskette FAT to find the clusters occupied by the AMIBOOT.ROM file.
F3h		Next, reading the AMIBOOT.ROM file, cluster by cluster.
F4h		The AMIBOOT.ROM file is not the correct size.
F5h		Next, disabling internal cache memory.
FBh		Next, detecting the type of flash ROM.
FCh		Next, erasing the flash ROM.
FDh		Next, programming the flash ROM.
FFh		Flash ROM programming was successful. Next, restarting the system BIOS.

B-3 Uncompressed Initialization Codes

The following runtime checkpoint codes are listed in order of execution.

These codes are uncompressed in F0000h shadow RAM.

Checkpoint	Code	Description
03h		The NMI is disabled. Next, checking for a soft reset or a power on condition.
05h		The BIOS stack has been built. Next, disabling cache memory.
06h		Uncompressing the POST code next.
07h		Next, initializing the CPU and the CPU data area.
08h		The CMOS checksum calculation is done next.
0Ah		The CMOS checksum calculation is done. Initializing the CMOS status register for date and time next.
0Bh		The CMOS status register is initialized. Next, performing any required

	initialization before the keyboard BAT command is issued.
0Ch	The keyboard controller input buffer is free. Next, issuing the BAT command to the keyboard controller.
0Eh	The keyboard controller BAT command result has been verified. Next, performing any necessary initialization after the keyboard controller BAT command test.
0Fh	The initialization after the keyboard controller BAT command test is done. The keyboard command byte is written next.
10h	The keyboard controller command byte is written. Next, issuing the Pin 23 and 24 blocking and unblocking command.
11h	Next, checking if <End or <Ins> keys were pressed during power on. Initializing CMOS RAM if the <i>Initialize CMOS RAM in every boot</i> AMIBIOS POST option was set in AMIBCP or the <End> key was pressed.
12h	Next, disabling DMA controllers 1 and 2 and interrupt controllers 1 and 2.
13h	The video display has been disabled. Port B has been initialized. Next, initializing the chipset.
14h	The 8254 timer test will begin next.
19h	The 8254 timer test is over. Starting the memory refresh test next.
1Ah	The memory refresh line is toggling. Checking the 15 second on/off time next.
2Bh	Passing control to the video ROM to perform any required configuration before the video ROM test.
2Ch	All necessary processing before passing control to the video ROM is done. Looking for the video ROM next and passing control to it.
2Dh	The video ROM has returned control to BIOS POST. Performing any required processing after the video ROM had control.
23h	Reading the 8042 input port and disabling the MEGAKEY Green PC feature next. Making the BIOS code segment writable and performing any necessary configuration before initializing the interrupt vectors.
24h	The configuration required before interrupt vector initialization has completed. Interrupt vector initialization is about to begin.

Checkpoint	Code	Description
25h		Interrupt vector initialization is done. Clearing the password if the POST DIAG switch is on.
27h		Any initialization before setting video mode will be done next.
28h		Initialization before setting the video mode is complete. Configuring the monochrome mode and color mode settings next.
2Ah		Bus initialization system, static, output devices will be done next, if present. See the last page for additional information.
2Eh		Completed post-video ROM test processing. If the EGA/VGA controller is not found, performing the display memory read/write test next.
2Fh		The EGA/VGA controller was not found. The display memory read/write test is about to begin.
30h		The display memory read/write test passed. Look for retrace checking next.
31h		The display memory read/write test or retrace checking failed. Performing the alternate display memory read/write test next.
32h		The alternate display memory read/write test passed. Looking for alternate display retrace checking next.
34h		Video display checking is over. Setting the display mode next.
37h		The display mode is set. Displaying the power on message next.
38h		Initializing the bus input, IPL, general devices next, if present. See the last page of this chapter for additional information.
39h		Displaying bus initialization error messages. See the last page of this chapter for additional information.
3Ah		The new cursor position has been read and saved. Displaying the <i>Hit </i> message next.
3Bh		The <i>Hit </i> message is displayed. The protected mode memory test is about to start.
40h		Preparing the descriptor tables next.
42h		The descriptor tables are prepared. Entering protected mode for the memory test next.
43h		Entered protected mode. Enabling interrupts for diagnostics mode next.
44h		Interrupts enabled if the diagnostics switch is on. Initializing data to check memory wraparound at 0:0 next.
45h		Data initialized. Checking for memory wraparound at 0:0 and finding the total system memory size next.
46h		The memory wraparound test is done. Memory size calculation has been done. Writing patterns to test memory next.
47h		The memory pattern has been written to extended memory. Writing patterns to the base 640 KB memory next.

Checkpoint	Code	Description
48h		Patterns written in base memory. Determining the amount of memory below 1 MB next.
49h		The amount of memory below 1 MB has been found and verified. Determining the amount of memory above 1 MB memory next.
4Bh		The amount of memory above 1 MB has been found and verified. Checking for a soft reset and clearing the memory below 1 MB for the soft reset next. If this is a power on situation, going to checkpoint 4Eh next.
4Ch		The memory below 1 MB has been cleared via a soft reset. Clearing the memory above 1 MB next.
4Dh		The memory above 1 MB has been cleared via a soft reset. Saving the memory size next. Going to checkpoint 52h next.
4Eh		The memory test started, but not as the result of a soft reset. Displaying the first 64 KB memory size next.
4Fh		The memory size display has started. The display is updated during the memory test. Performing the sequential and random memory test next.
50h		The memory below 1 MB has been tested and initialized. Adjusting the displayed memory size for relocation and shadowing next.
51h		The memory size display was adjusted for relocation and shadowing. Testing the memory above 1 MB next.
52h		The memory above 1 MB has been tested and initialized. Saving the memory size information next.
53h		The memory size information and the CPU registers are saved. Entering real mode next.
54h		Shutdown was successful. The CPU is in real mode. Disabling the Gate A20 line, parity, and the NMI next.
57h		The A20 address line, parity, and the NMI are disabled. Adjusting the memory size depending on relocation and shadowing next.
58h		The memory size was adjusted for relocation and shadowing. Clearing the <i>Hit </i> message next.
59h		The <i>Hit </i> message is cleared. The <i><WAIT...></i> message is displayed. Starting the DMA and interrupt controller test next.

Checkpoint	Code	Description
60h		The DMA page register test passed. Performing the DMA Controller 1 base register test next.
62h		The DMA controller 1 base register test passed. Performing the DMA controller 2 base register test next.
65h		The DMA controller 2 base register test passed. Programming DMA controllers 1 and 2 next.
66h		Completed programming DMA controllers 1 and 2. Initializing the 8259 interrupt controller next.
67h		Completed 8259 interrupt controller initialization.
7Fh		Extended NMI source enabling is in progress.
80h		The keyboard test has started. Clearing the output buffer and checking for stuck keys. Issuing the keyboard reset command next.
81h		A keyboard reset error or stuck key was found. Issuing the keyboard controller interface test command next.
82h		The keyboard controller interface test completed. Writing the command byte and initializing the circular buffer next.
83h		The command byte was written and global data initialization has completed. Checking for a locked key next.
84h		Locked key checking is over. Checking for a memory size mismatch with CMOS RAM data next.
85h		The memory size check is done. Displaying a soft error and checking for a password or bypassing WINBIOS Setup next.
86h		The password was checked. Performing any required programming before WINBIOS Setup next.
87h		The programming before WINBIOS Setup has completed. Uncompressing the WINBIOS Setup code and executing the AMIBIOS Setup or WINBIOS Setup utility next.
88h		Returned from WINBIOS Setup and cleared the screen. Performing any necessary programming after WINBIOS Setup next.
89h		The programming after WINBIOS Setup has completed. Displaying the power on screen message next.
8Bh		The first screen message has been displayed. The <WAIT...> message is displayed. Performing the PS/2 mouse check and extended BIOS data area allocation check next.
8Ch		Programming the WINBIOS Setup options next.
8Dh		The WINBIOS Setup options are programmed. Resetting the hard disk controller next.
8Fh		The hard disk controller has been reset. Configuring the floppy drive controller next.
91h		The floppy drive controller has been configured. Configuring the hard disk drive controller next.

Checkpoint	Code	Description
95h		Initializing the bus option ROMs from C800 next. See the last page of this chapter for additional information.
96h		Initializing before passing control to the adaptor ROM at C800.
97h		Initialization before the C800 adaptor ROM gains control has completed. The adaptor ROM check is next.
98h		The adaptor ROM had control and has now returned control to BIOS POST. Performing any required processing after the option ROM returned control.
99h		Any initialization required after the option ROM test has completed. Configuring the timer data area and printer base address next.
9Ah		Set the timer and printer base addresses. Setting the RS-232 base address next.
9Bh		Returned after setting the RS-232 base address. Performing any required initialization before the Coprocessor test next.
9Ch		Required initialization before the Coprocessor test is over. Initializing the Coprocessor next.
9Dh		Coprocessor initialized. Performing any required initialization after the Coprocessor test next.
9Eh		Initialization after the Coprocessor test is complete. Checking the extended keyboard, keyboard ID, and Num Lock key next. Issuing the keyboard ID command next.
A2h		Displaying any soft errors next.
A3h		The soft error display has completed. Setting the keyboard typematic rate next.
A4h		The keyboard typematic rate is set. Programming the memory wait states next.
A5h		Memory wait state programming is over. Clearing the screen and enabling parity and the NMI next.
A7h		NMI and parity enabled. Performing any initialization required before passing control to the adaptor ROM at E000 next.
A8h		Initialization before passing control to the adaptor ROM at E000h completed. Passing control to the adaptor ROM at E000h next.
A9h		Returned from adaptor ROM at E000h control. Performing any initialization required after the E000 option ROM had control next.
Aah		Initialization after E000 option ROM control has completed. Displaying the system configuration next.
Abh		Uncompressing the DMI data and executing DMI POST initialization next.
B0h		The system configuration is displayed.
B1h		Copying any code to specific areas.
00h		Code copying to specific areas is done. Passing control to INT 19h boot loader next.

Notes

Appendix C

System Specifications

Processors

Single or dual 604-pin Intel® Xeon™ processors at a front side (system) bus speed of 800 MHz. (Please refer to the support section of our web site for a complete listing of supported processors: www.supermicro.com).

Chipset

Intel E7525 chipset

BIOS

8 MB AMI® Flash ROM

Memory Capacity

Six 184-pin DIMM sockets supporting up to 12 GB of registered ECC DDR333 or 24 GB of registered ECC DDR266 SDRAM

Note: Interleaved memory - requires memory to be installed two at a time. See the memory section in Chapter 5 for details.

Serial ATA Controller (7034A-T only)

Marvell SATA controller providing a four-port Serial ATA subsystem.

Peripheral Drives/Bays

One (1) 3.5" floppy drive

Two (2) 5.25" drive bays

Four (4) SATA drive bays (7034A-T only)

Expansion Slots

Chassis: Seven (7) I/O chassis slots

Serverboard: total of six (6) PCI-Express/PCI-X slots

Serverboard (7034A-T/7034A-i)

Model: X6DAL-TG/X6DAL-G (Extended ATX)

Dimensions: 12 x 10 in (305 x 254 mm)

Chassis (7034A-T/7034A-i)

Model: SC733T-645/SC733i-645 (tower)

Dimensions: (WxHxD) 6.94" x 17.125 x 24.125 in. (17.6 x 435 x 612.8 mm)

Weight

Gross (Bare Bone): 40 lbs. (18.2 kg.)

System Cooling (all fan speed controlled by BIOS setting: p. 7-19)

One (1) 9-cm chassis fan

One (1) 12-cm exhaust fan

System Input Requirements

AC Input Voltage: 100-240 VAC

Rated Input Current: 11A @ 90V

Rated Input Frequency: 50 to 60 Hz

Power Supply

Rated Output Power: 645W (Model# SP645-PS, Part# PWS-0060)

Rated Output Voltages: +12Vtotal (46A), +5V (30A), +3.3V (30A), +5Vsb (4.0A)

Operating Environment

Operating Temperature: 10° to 35° C (50° to 95° F)

Non-operating Temperature: -40° to 70° C (-40° to 158° F)

Operating Relative Humidity: 8% to 90% (non-condensing)

Non-operating Relative Humidity: 5 to 95% (non-condensing)

Regulatory Compliance

Electromagnetic Emissions:

FCC Class B, EN 55022 Class B, EN 61000-3-2/-3-3, CISPR 22 Class B

Electromagnetic Immunity:

EN 55024/CISPR 24, (EN 61000-4-2, EN 61000-4-3, EN 61000-4-4, EN 61000-4-5, EN 61000-4-6, EN 61000-4-8, EN 61000-4-11)

Safety:

EN 60950/IEC 60950-Compliant

UL Listed (USA)

CUL Listed (Canada)

TUV Certified (Germany)

CE Marking (Europe)

Notes