



**SUPERSERVER<sup>®</sup>**  
**SYS-E302-12A-4C**  
**SYS-E302-12A-8C**



**USER'S MANUAL**

Revision 1.0

The information in this User's Manual has been carefully reviewed and is believed to be accurate. The vendor assumes no responsibility for any inaccuracies that may be contained in this document, and makes no commitment to update or to keep current the information in this manual, or to notify any person or organization of the updates. Please Note: For the most up-to-date version of this manual, please see our website at [www.supermicro.com](http://www.supermicro.com).

Super Micro Computer, Inc. ("Supermicro") reserves the right to make changes to the product described in this manual at any time and without notice. This product, including software and documentation, is the property of Supermicro and/or its licensors, and is supplied only under a license. Any use or reproduction of this product is not allowed, except as expressly permitted by the terms of said license.

IN NO EVENT WILL Super Micro Computer, Inc. BE LIABLE FOR DIRECT, INDIRECT, SPECIAL, INCIDENTAL, SPECULATIVE OR CONSEQUENTIAL DAMAGES ARISING FROM THE USE OR INABILITY TO USE THIS PRODUCT OR DOCUMENTATION, EVEN IF ADVISED OF THE POSSIBILITY OF SUCH DAMAGES. IN PARTICULAR, SUPER MICRO COMPUTER, INC. SHALL NOT HAVE LIABILITY FOR ANY HARDWARE, SOFTWARE, OR DATA STORED OR USED WITH THE PRODUCT, INCLUDING THE COSTS OF REPAIRING, REPLACING, INTEGRATING, INSTALLING OR RECOVERING SUCH HARDWARE, SOFTWARE, OR DATA.

Any disputes arising between manufacturer and customer shall be governed by the laws of Santa Clara County in the State of California, USA. The State of California, County of Santa Clara shall be the exclusive venue for the resolution of any such disputes. Supermicro's total liability for all claims will not exceed the price paid for the hardware product.

FCC Statement: This equipment has been tested and found to comply with the limits for a Class A or Class B digital device pursuant to Part 15 of the FCC Rules. These limits are designed to provide reasonable protection against harmful interference when the equipment is operated in industrial environment for Class A device or in residential environment for Class B device. This equipment generates, uses, and can radiate radio frequency energy and, if not installed and used in accordance with the manufacturer's instruction manual, may cause harmful interference with radio communications. Operation of this equipment in a residential area is likely to cause harmful interference, in which case you will be required to correct the interference at your own expense.

California Best Management Practices Regulations for Perchlorate Materials: This Perchlorate warning applies only to products containing CR (Manganese Dioxide) Lithium coin cells. "Perchlorate Material-special handling may apply. See [www.dtsc.ca.gov/hazardouswaste/perchlorate](http://www.dtsc.ca.gov/hazardouswaste/perchlorate)".



WARNING: This product can expose you to chemicals including lead, known to the State of California to cause cancer and birth defects or other reproductive harm. For more information, go to [www.P65Warnings.ca.gov](http://www.P65Warnings.ca.gov).

The products sold by Supermicro are not intended for and will not be used in life support systems, medical equipment, nuclear facilities or systems, aircraft, aircraft devices, aircraft/emergency communication devices or other critical systems whose failure to perform be reasonably expected to result in significant injury or loss of life or catastrophic property damage. Accordingly, Supermicro disclaims any and all liability, and should buyer use or sell such products for use in such ultra-hazardous applications, it does so entirely at its own risk. Furthermore, buyer agrees to fully indemnify, defend and hold Supermicro harmless for and against any and all claims, demands, actions, litigation, and proceedings of any kind arising out of or related to such ultra-hazardous use or sale.

Manual Revision 1.0

Release Date: March 01, 2023

Unless you request and receive written permission from Super Micro Computer, Inc., you may not copy any part of this document. Information in this document is subject to change without notice. Other products and companies referred to herein are trademarks or registered trademarks of their respective companies or mark holders.

Copyright © 2023 by Super Micro Computer, Inc.  
All rights reserved.

**Printed in the United States of America**

# Preface

## About this Manual

This manual is written for professional system integrators and PC technicians. It provides information for the installation and use of the server. Installation and maintenance should be performed by experienced technicians only.

Please refer to the SYS-E302-12A-4C/8C server specifications page on our website for updates on supported memory, processors and operating systems (<http://www.supermicro.com>).

## Notes

For your system to work properly, please follow the links below to download all necessary drivers/utilities and the user's manual for your server.

- Supermicro product manuals: <http://www.supermicro.com/support/manuals/>
- Product drivers and utilities: <https://www.supermicro.com/wdl/driver>
- Product safety info: [http://www.supermicro.com/about/policies/safety\\_information.cfm](http://www.supermicro.com/about/policies/safety_information.cfm)

If you have any questions, please contact our support team at:  
[support@supermicro.com](mailto:support@supermicro.com)

This manual may be periodically updated without notice. Please check the Supermicro website for possible updates to the manual revision level.

## Secure Data Deletion

A secure data deletion tool designed to fully erase all data from storage devices can be found on our website: [https://www.supermicro.com/about/policies/disclaimer.cfm?url=/wdl/utility/Lot9\\_Secure\\_Data\\_Deletion\\_Utility/](https://www.supermicro.com/about/policies/disclaimer.cfm?url=/wdl/utility/Lot9_Secure_Data_Deletion_Utility/)

## Warnings

Special attention should be given to the following symbols used in this manual.



**Warning!** Indicates important information given to prevent equipment/property damage or personal injury.



**Warning!** Indicates high voltage may be encountered when performing a procedure.

# Contents

Contacting Supermicro.....	6
<b>Chapter 1 Introduction</b>	
1.1 Overview.....	7
1.2 System Features .....	8
Front View .....	8
Control Panel.....	8
1.3 Motherboard Layout .....	10
Quick Reference Table.....	11
System Block Diagram.....	13
<b>Chapter 2 Server Installation</b>	
2.1 Overview.....	14
2.2 Preparing for Setup.....	14
Choosing a Setup Location.....	14
Rack Precautions .....	14
Server Precautions.....	15
Rack Mounting Considerations .....	15
Ambient Operating Temperature.....	15
Airflow .....	15
Mechanical Loading.....	16
Circuit Overloading .....	16
Reliable Ground.....	16
Adding Components to your System .....	17
2.3 Mounting on a Wall .....	18
<b>Chapter 3 Maintenance and Component Installation</b>	
3.1 Removing Power.....	21
3.2 Accessing the System.....	22
3.3 Static-Sensitive Devices.....	23
Precautions .....	23
3.4 Memory Support and Installation .....	24
Memory Support.....	24
Memory Population Guidelines .....	24
General Guidelines for Optimizing Memory Performance .....	24
Installing Memory .....	26

---

---

Motherboard Battery .....	27
3.5 Chassis Components .....	28
Installing the Storage Drive.....	28
<b>Chapter 4 Motherboard Connections</b>	
4.1 Power Connections .....	31
4.2 Headers and Connectors .....	32
Control Panel .....	36
4.3 Ports .....	38
4.4 Jumpers.....	40
Explanation of Jumpers.....	40
4.5 LED Indicators.....	43
<b>Chapter 5 Software</b>	
5.1 SuperDoctor® 5.....	44
5.2 BMC.....	45
BMC ADMIN User Password .....	45
<b>Appendix A Standardized Warning Statements for AC Systems</b>	
<b>Appendix B System Specifications</b>	

## Contacting Supermicro

### Headquarters

Address: Super Micro Computer, Inc.  
980 Rock Ave.  
San Jose, CA 95131 U.S.A.

Tel: +1 (408) 503-8000

Fax: +1 (408) 503-8008

Email: [marketing@supermicro.com](mailto:marketing@supermicro.com) (General Information)  
[Sales-USA@supermicro.com](mailto:Sales-USA@supermicro.com) (Sales Inquiries)  
[Government\\_Sales-USA@supermicro.com](mailto:Government_Sales-USA@supermicro.com) (Gov. Sales Inquiries)  
[support@supermicro.com](mailto:support@supermicro.com) (Technical Support)  
[RMA@supermicro.com](mailto:RMA@supermicro.com) (RMA Support)  
[Webmaster@supermicro.com](mailto:Webmaster@supermicro.com) (Webmaster)

Website: [www.supermicro.com](http://www.supermicro.com)

### Europe

Address: Super Micro Computer B.V.  
Het Sterrenbeeld 28, 5215 ML  
's-Hertogenbosch, The Netherlands

Tel: +31 (0) 73-6400390

Fax: +31 (0) 73-6416525

Email: [Sales\\_Europe@supermicro.com](mailto:Sales_Europe@supermicro.com) (Sales Inquiries)  
[Support\\_Europe@supermicro.com](mailto:Support_Europe@supermicro.com) (Technical Support)  
[RMA\\_Europe@supermicro.com](mailto:RMA_Europe@supermicro.com) (RMA Support)

Website: [www.supermicro.nl](http://www.supermicro.nl)

### Asia-Pacific

Address: Super Micro Computer, Inc.  
3F, No. 150, Jian 1st Rd.  
Zhonghe Dist., New Taipei City 235  
Taiwan (R.O.C)

Tel: +886-(2) 8226-3990

Fax: +886-(2) 8226-3992

Email: [Sales-Asia@supermicro.com.tw](mailto:Sales-Asia@supermicro.com.tw) (Sales Inquiries)  
[Support@supermicro.com.tw](mailto:Support@supermicro.com.tw) (Technical Support)  
[RMA@supermicro.com.tw](mailto:RMA@supermicro.com.tw) (RMA Support)

Website: [www.supermicro.com.tw](http://www.supermicro.com.tw)

# Chapter 1

## Introduction

### 1.1 Overview

This chapter provides a brief outline of the functions and features of the SuperServer SYS-E302-12A-4C/8C. It is based on the A3SPI-4C-LN6PF/8C-LN6PF motherboard and the CSE-302iL chassis.

The following provides an overview of the specifications and capabilities.

System Overview	
<b>Motherboard</b>	SYS-E302-12A-4C: A3SPI-4C-LN6PF SYS-E302-12A-8C: A3SPI-8C-LN6PF
<b>Chassis</b>	CSE-302iL
<b>Processor Support</b>	SYS-E302-12A-4C: Single Intel Atom® Processor C5315 SYS-E302-12A-8C: Single Intel Atom® Processor C5325
<b>Memory</b>	Up to 128GB of DDR4 ECC RDIMM memory to 2400 MT/s (4C) and 2933 MT/S (8C)
<b>Drive Support</b>	Two M.2 slots (PCIe) One M.2 (PCIe 3.0 x2 / USB 3.0 / SATA3, B-Key 3052) One M.2 (PCIe 3.0 x4, M-Key 2280) One 2.5" SSD
<b>Expansion Slots</b>	One PCIe 3.0 x2 (in x8) One OCuLink supports PCIe x4/SATA/NVMe
<b>I/O Ports*</b>	One RJ45 Dedicated IPMI LAN port Four RJ45 Gigabit Ethernet LAN ports Two SFP+ 10GbE LAN ports Two USB 3.0 port(s) (2 USB) One VGA port
<b>System Cooling</b>	Fanless
<b>Power</b>	One external 150 watt DC power adapter
<b>Form Factor</b>	Compact: 11.6" x 2.9" x 8.1" (295 x 73 x 205mm) (WxHxD)

**Notes:** A Quick Reference Guide can be found on the product page of the Supermicro website.

The following safety models associated with the SYS-E302-12A-4C/8C have been certified as compliant with UL or CSA: E302iL-15, E302iL-A15A3.

## 1.2 System Features

The following views of the system display the main features. Refer to [Appendix B](#) for additional specifications.

### Front View



**Figure 1-1. Front View**

System Features: Front	
Feature	Description
Power button	The main power switch applies or removes primary power from the power supply to the server but maintains standby power. To perform most maintenance tasks, unplug the system to remove all power.
Power LED and HDD LED	Indicates power is being supplied to the system power supply units. This LED is illuminated when the system is operating normally. Indicates hard disk drive activity when flashing.

**Figure 1-2. Control Panel**

## Rear View

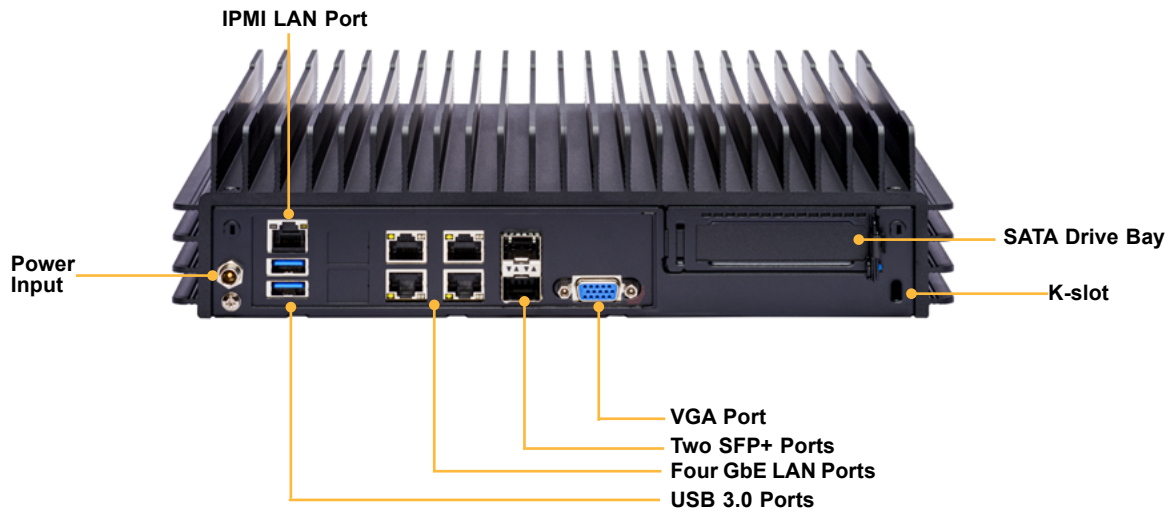

Figure 1-2. System: Rear View

System Features: Rear	
Feature	Description
Power input	The main power switch applies or removes primary power from the power supply to the server but maintains standby power. To perform most maintenance tasks, unplug the system to remove all power.
LAN Ports	One dedicated IPMI LAN port, four GbE LAN ports, two 10 GbE SFP+ ports
USB Ports	Two USB 3.0 ports
VGA Port	Video port
SATA Drive Bay	2.5" drive bay for SATA SSD
K-slot for lock	Accepts a standard Kensington cable locking device (not included).

## 1.3 Motherboard Layout

Below is a layout of the A3SPI-4C-LN6PF/8C-LN6PF motherboard with jumper, connector and LED locations shown. See the table on the following page for descriptions. For detailed descriptions, pinout information and jumper settings, refer to [Chapter 3](#) or the [Motherboard Manual](#).

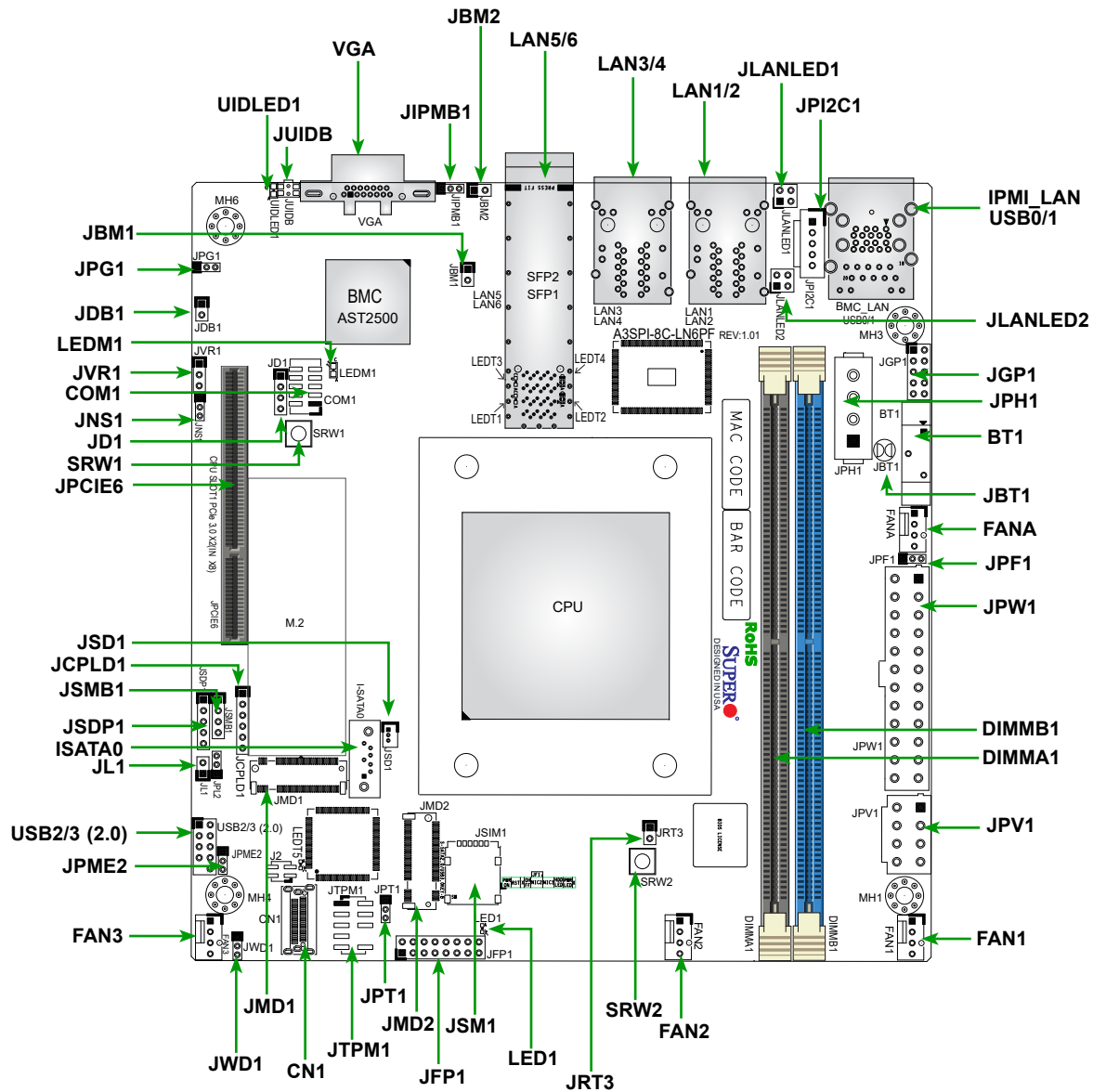

Figure 1-6. Motherboard Layout

## Quick Reference Table

<b>Jumper</b>	<b>Description</b>	<b>Default Setting</b>
JBM1	Disable IPMI Shared LAN	Pins 1-2 Open: Enable
JBM2	Disable IPMI Dedicated LAN	Pins 1-2 Open: Enable
JBT1	CMOS Clear	Open: Normal
JDB1	COM Port or BMC Debug Port Select	Open: COM PORT
JNS1	OCuLink to SATA or PCIe Mode Selection	Pins 1-2: SATA (Default) Pins 2-3: NVMe
JPF1	ATX or Force PS-ON Mode	Pins 1-2: ATX Mode Pins 2-3: Force PS-ON Mode
JPG1	Onboard VGA Enable/Disable	Pins 1-2: Enabled (Default) Pins 2-3: Disable VGA
JPME2	ME Manufacturing Mode	Pins 1-2: Normal
JPT1	Onboard TPM Enable/Disable	Pins 1-2: Enabled
JWD1	Watch Dog	Pins 1-2: Reset
<b>LED</b>	<b>Description</b>	<b>Status</b>
LED1	Power LED	Solid Green: Power On
LEDM1	BMC Heartbeat	Blinking Green: BMC Normal
UIDLED1	UID LED	Solid Blue: Unit Identified
<b>Connector</b>	<b>Description</b>	
CN1	OCuLink Connector (to PCIe x4/SATA or NVMe)	
BT1	Onboard Battery	
COM1	COM Header	
FAN1/2/3, FANA	System Fan Headers	
IPMI_LAN	Dedicated IPMI LAN Port	
I-SATA0	SATA 3.0 Port (I-SATA0: SuperDOM)	
JCPLD1	Complex-Programmable Logical Device (CPLD) header	
JD1	Speaker Header	
JFP1	Front Control Panel Header	
JGP1	General Purpose I/O Header	
JIPMB1	System Management Bus Header (for IPMI card)	
JL1	Chassis Intrusion Header	
JLANLED1	LAN1/LAN2 Activity LED Header	
JLANLED2	LAN3/LAN4 Activity LED Header	
JMD1	M.2 Slot (PCIe 3.0 x4, M-Key 2280) (For 4C SKU with C5315 CPU, only M.2 or OcuLink is available)	
JMD2	M.2 Slot (PCIe 3.0 x2 / USB 3.0 / SATA3, B-Key 3052) (SATA mux with I-SATA0)	
JPCIE6	PCIe 3.0 x2 (in x8)	

<b>Connector</b>	<b>Description</b>
JPH1	4-pin HDD and NVMe HDD Power Connector
JPI <sup>2</sup> C1	Power Supply SMBus I <sup>2</sup> C Header (if the power supply has the PMbus 1x5 (male) pin)
JPV1	8-pin 12V DC Power Connector
JPW1	24-pin ATX Power Connector
JRT3	Thermal Diode Header
JSD1	SATA DOM Power Connector
JSDP1	Software Defined Pins
JSIM1	Nano SIM Card Slot
JSMB1	System Management Bus Header
JTPM1	Trusted Platform Module (TPM)/Port80 Header
JUIDB	UID Switch
JVR1	VRM Programming Header (Manufacturing Use Only)
LAN1–LAN4	Gigabit Ethernet RJ45 Ports
LAN5–LAN6	SFP LAN Ports (LAN5: SFP1, LAN6: SFP2)
SRW1, SRW2	M.2 Mounting Screws
USB0/1	Back Panel USB 3.0 Ports
USB2/3	USB 2.0 Headers
VGA	VGA Port

## System Block Diagram

The block diagram below shows the connections and relationships between the subsystems and major components of the overall system.

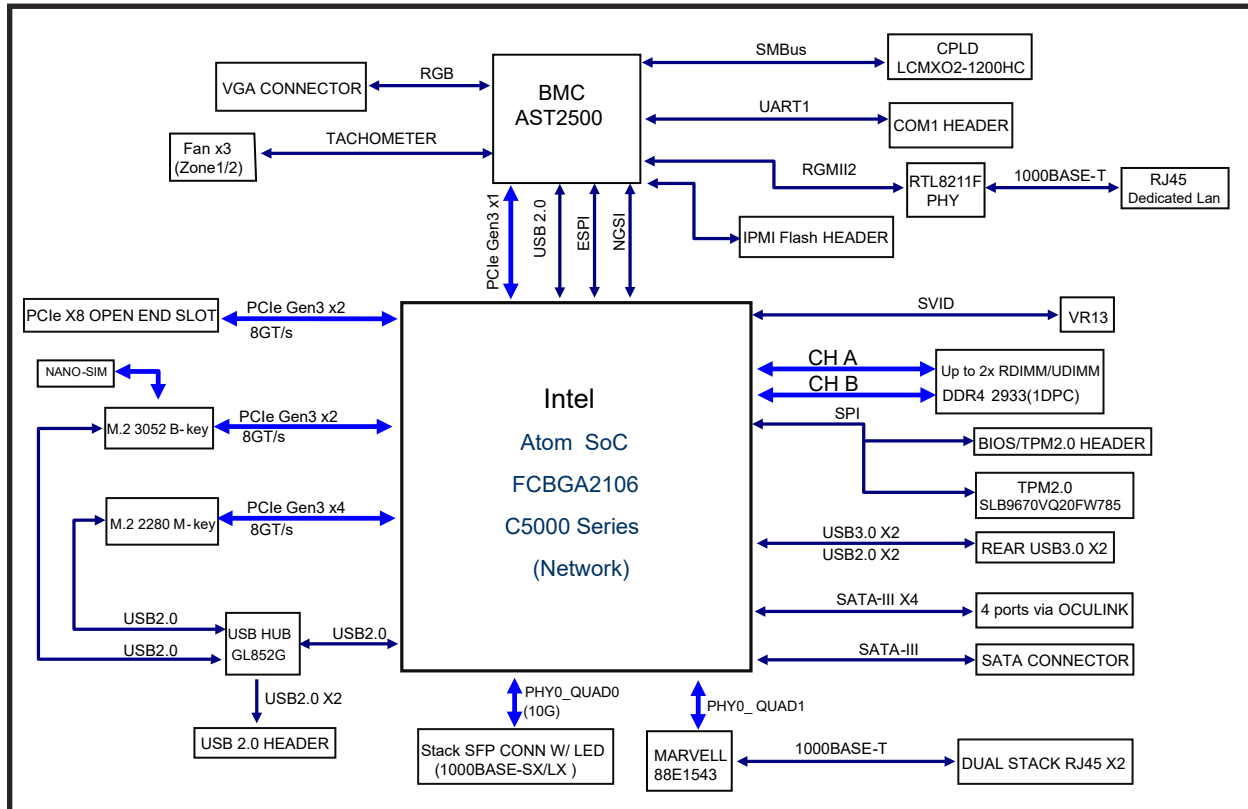

Figure 1-6. System Block Diagram

# Chapter 2

## Server Installation

### 2.1 Overview

This chapter provides advice and instructions for mounting your system in a server rack. If your system is not already fully integrated with processors, system memory, etc., refer to Chapter 3 for details on installing those components.

**Caution:** Electrostatic Discharge (ESD) can damage electronic components. To prevent such damage to PCBs (printed circuit boards), use a grounded wrist strap, handle all PCBs by their edges, and keep them in anti-static bags when not in use.

### 2.2 Preparing for Setup

The box in which the system was shipped includes the screws needed to install the server into a rack. Read this section in its entirety before you begin the installation.

#### Choosing a Setup Location

- The system should be situated in a clean, dust-free area that is well ventilated. Avoid areas where heat, electrical noise, and electromagnetic fields are generated.
- Leave at least 25 inches of clearance in front of the rack so that you can open the front door completely. Leave approximately 30 inches of clearance behind the rack to allow sufficient space for airflow and access when servicing.
- This product should be installed only in a Restricted Access Location (dedicated equipment rooms, service closets, etc.).
- This product is not suitable for use with visual display workplace devices according to §2 of the German Ordinance for Work with Visual Display Units.

#### Rack Precautions

- Verify that the leveling jacks on the bottom of the rack are extended to the floor so that the full weight of the rack rests on them.

- In single-rack installations, stabilizers should be attached to the rack. In multi-rack installations, the racks should be coupled together.
- Always verify that the rack is stable before extending a server or other component from the rack.
- You should extend only one server or component at a time. Extending two or more simultaneously might cause the rack to become unstable.

## Server Precautions

- Review the electrical and general safety precautions in Appendix B.
- Determine the placement of each component in the rack *before* you install the rails.
- Install the heaviest server components at the bottom of the rack first. Subsequent components should be installed in decreasing order of weight with the lightest component at the top.
- Use a regulating uninterruptible power supply (UPS) to protect the server from power surges and voltage spikes and to keep your system operating in case of a power failure.
- Allow any drives and power supply modules to cool before touching them.
- When not servicing, always keep the front door of the rack and all covers and panels closed to maintain proper cooling.

## Rack Mounting Considerations

### *Ambient Operating Temperature*

If installed in a closed or multi-unit rack assembly, the ambient operating temperature of the rack environment might be greater than the room's ambient temperature. Therefore, consideration should be given to installing the equipment in an environment compatible with the manufacturer's maximum rated ambient temperature (TMRA).

### *Airflow*

Equipment should be mounted into a rack so that the amount of airflow required for safe operation is not compromised.

### ***Mechanical Loading***

Equipment should be mounted into a rack so that a hazardous condition does not arise due to uneven mechanical loading.

### ***Circuit Overloading***

Consideration should be given to the connection of the equipment to the power supply circuitry and the effect that any possible overloading of circuits might have on overcurrent protection and power supply wiring. Appropriate consideration of equipment nameplate ratings should be used when addressing this concern.

### ***Reliable Ground***

A reliable ground must be maintained at all times. To ensure this, the rack itself should be grounded. Particular attention should be given to power supply connections other than the direct connections to the branch circuit (i.e. the use of power strips, etc.).



To prevent bodily injury when mounting or servicing this unit in a rack, you must take special precautions to ensure that the system remains stable. The following guidelines are provided to ensure your safety:

- This unit should be mounted at the bottom of the rack if it is the only unit in the rack.
- When mounting this unit in a partially filled rack, load the rack from the bottom to the top with the heaviest component at the bottom of the rack.
- If the rack is provided with stabilizing devices, install the stabilizers before mounting or servicing the unit in the rack.



Mounted equipment is not to be used as a shelf or a work space.



**Warning:** Do not pick up the server with the front handles. They are designed to pull the system from a rack only.

## Adding Components to your System

- **Memory:** If your system is not already fully integrated with system memory, refer to Chapter 3 for details on compatible types of memory and the installation procedure.
- **Drives and Storage:** To add storage capabilities to your server, see Chapter 3.
- **Input/Output:** See Chapter 4 for I/O ports and connect them, as needed.
- **Software:** See Chapter 5 for description and procedures for installing software, including drivers and monitoring programs.

## 2.3 Mounting on a Wall

The chassis can be mounted on a wall using a bracket (optional, MCP-290-30201-0B).

1. Secure the bracket to the wall where you want the server to be mounted by using four screws through the holes around the center of the bracket, as shown below.

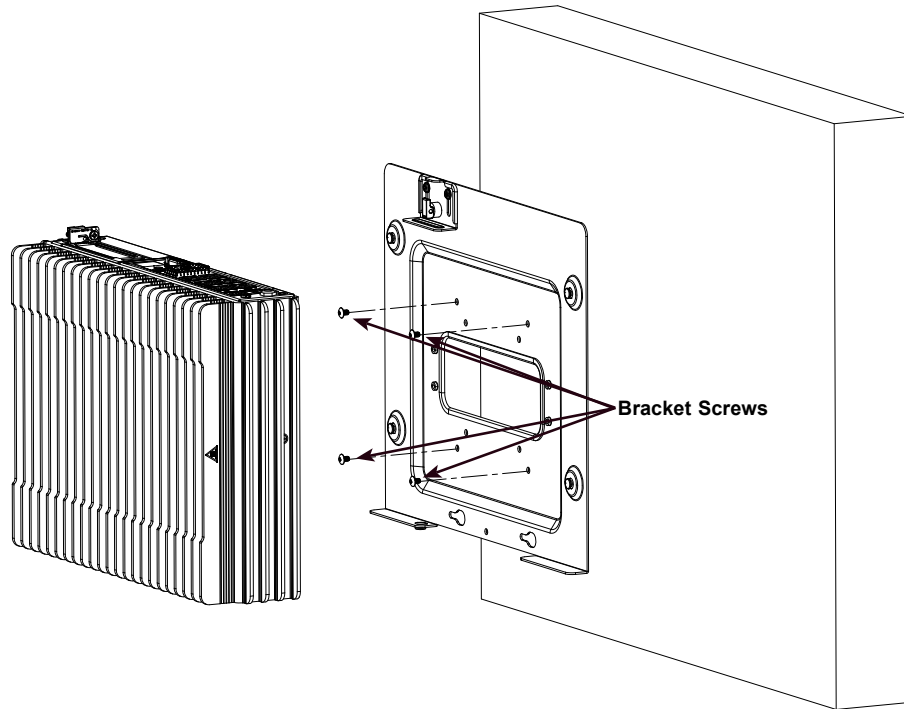

**Figure 2-1. Installing the Mounting Bracket**

2. Flip the tab of the latch on the top of the chassis bracket to unlock the latch, then slide the latch upward.

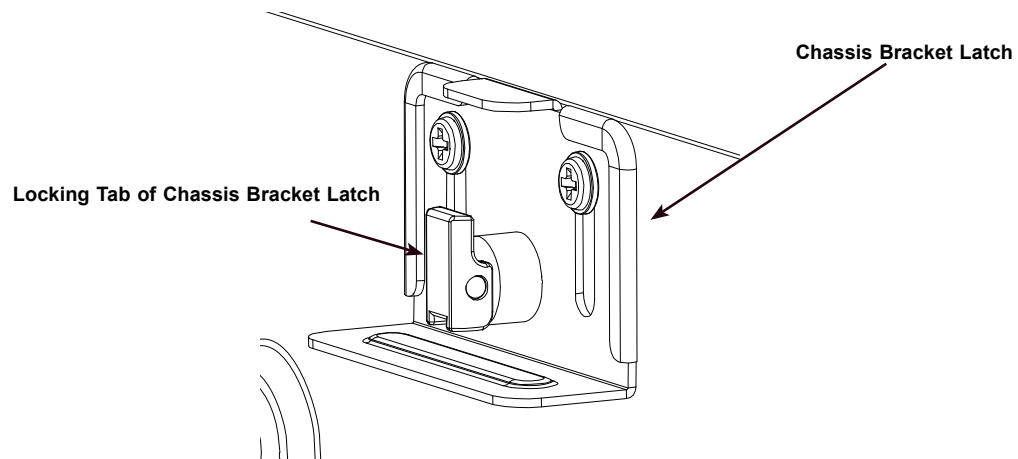

**Figure 2-2. Chassis Bracket Latch**

- 3. With the input/output ports facing up, hang the server on the mounting bracket by hooking the four keyholes on the bottom of the chassis on the four knobs of the bracket.

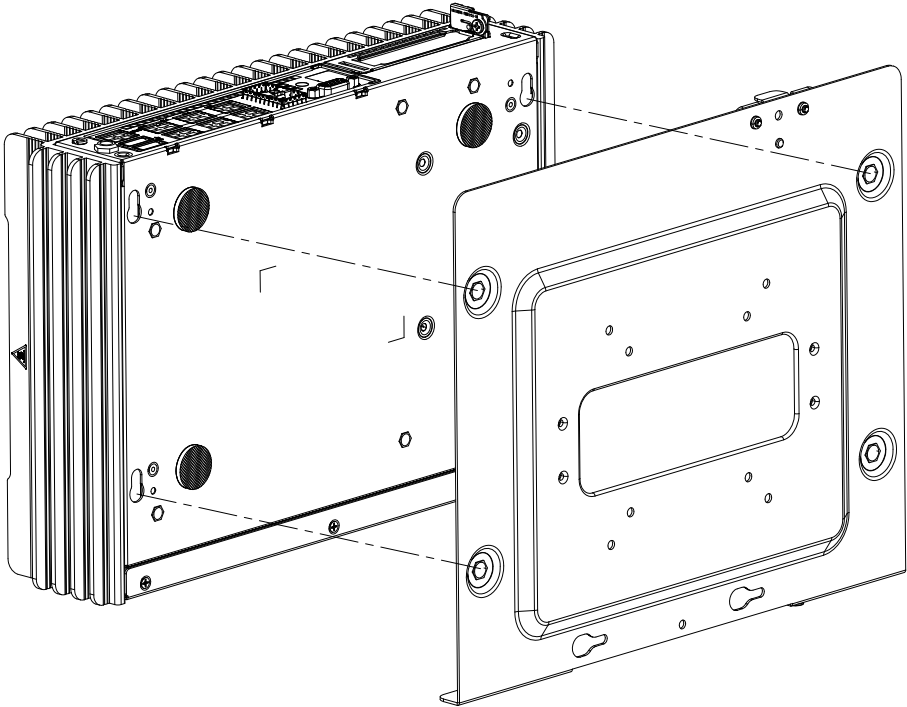

Figure 2-3. Hanging Server on the Bracket

- 4. Secure the chassis to the bracket by sliding the latch back down and flipping the tab to lock it in place.
- 5. An additional bracket for a power adapter can be attached to the bottom of the chassis bracket with a screw, as pictured below.

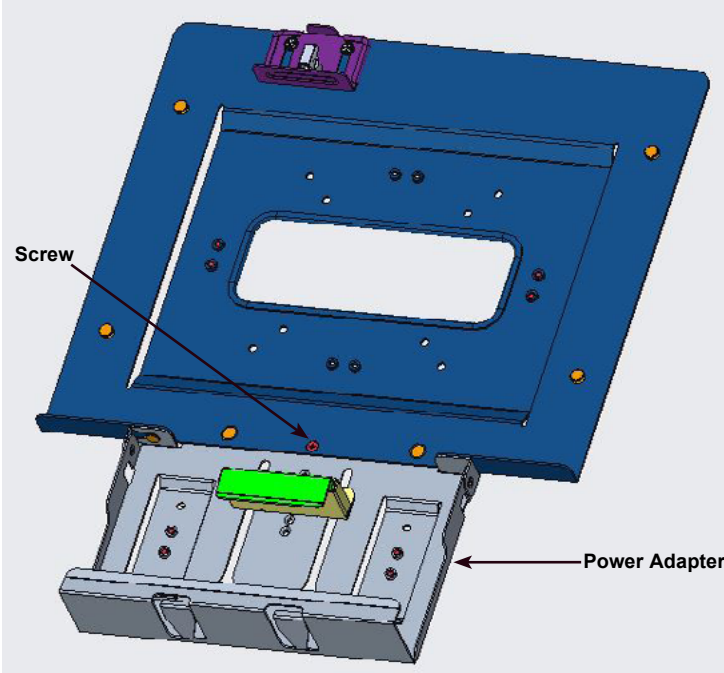
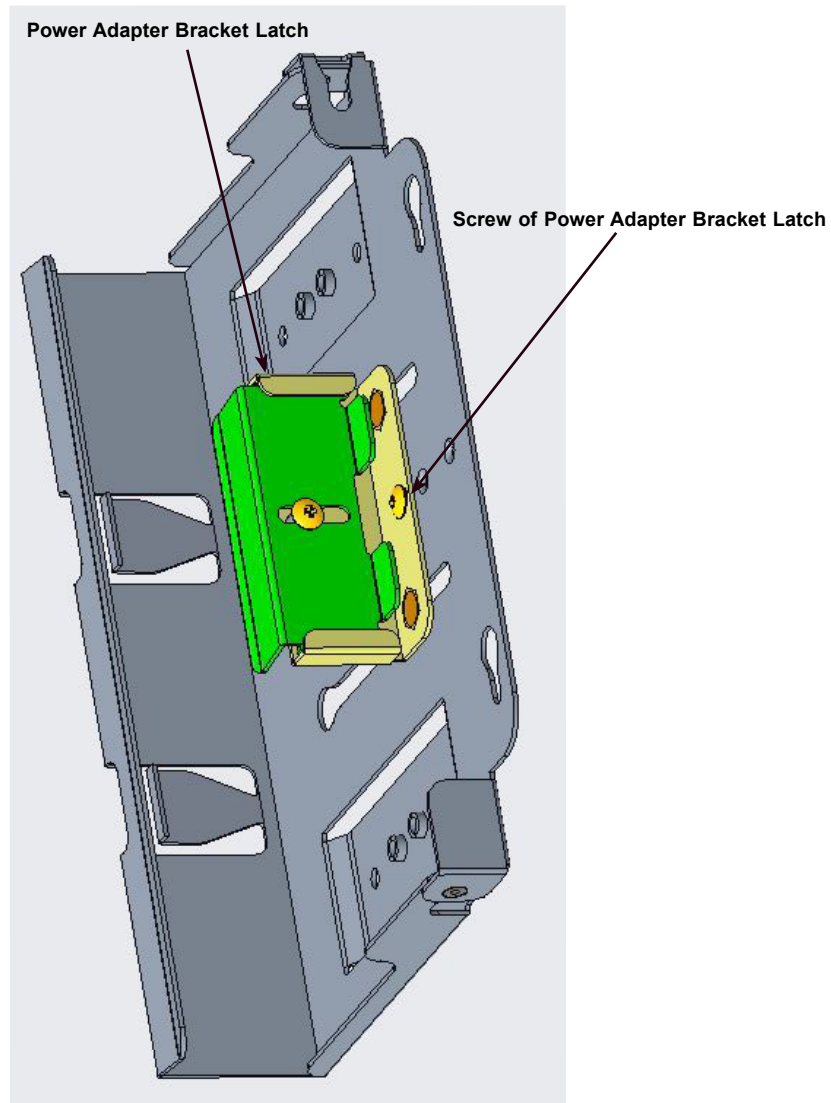

Figure 2-4. Chassis Bracket with Power Adapter Bracket Attached

6. The power adapter can be secured to this lower bracket by partially unscrewing its latch, sliding the latch upward, placing the power adapter in the bracket, lowering the latch, and tightening the screw to secure it in place.



**Figure 2-5. Power Adapter Bracket**

## Chapter 3

# Maintenance and Component Installation

This chapter provides instructions on installing and replacing main system components. To prevent compatibility issues, only use components that match the specifications and/or part numbers given.

Installation or replacement of most components require that power first be removed from the system. Please follow the procedures given in each section.

### 3.1 Removing Power

Use the following procedure to ensure that power has been removed from the system. This step is necessary when removing or installing non hot-swap components or when replacing a non-redundant power supply.

1. Use the operating system to power down the system.
2. After the system has completely shut-down, disconnect the AC adapter power cord from the power source.
3. Disconnect the power cord from the chassis.

## 3.2 Accessing the System

The CSE-302iL features a removable top cover to access the inside of the chassis.

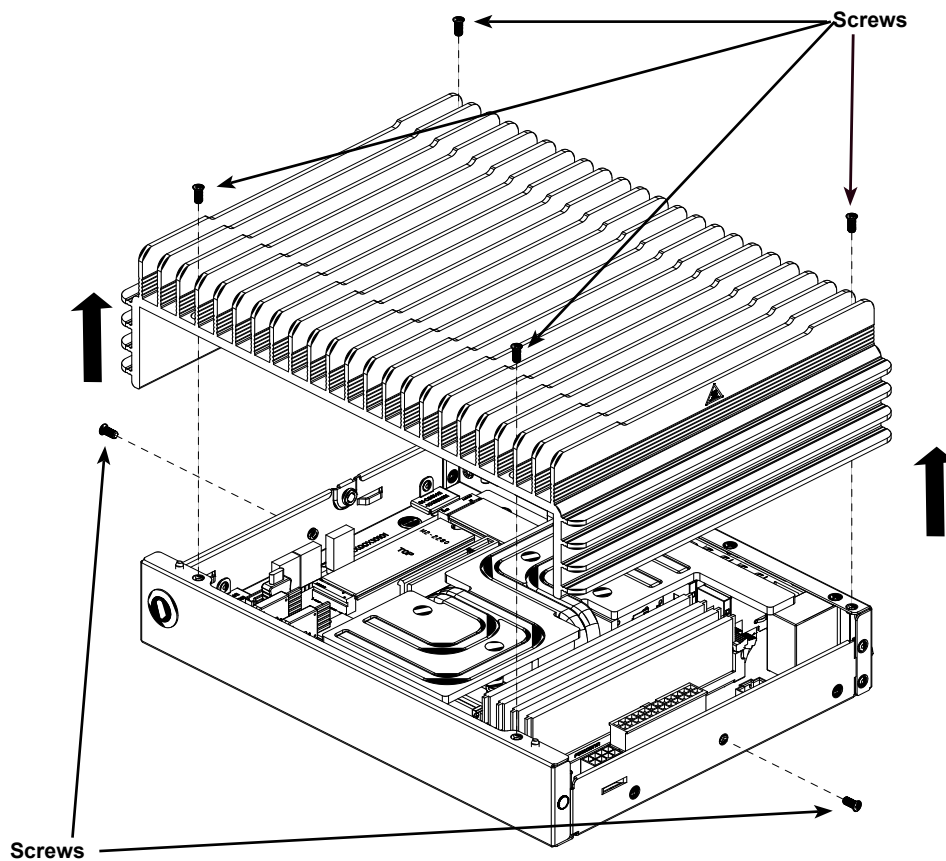

Figure 3-1. Removing the Chassis Cover

### *Removing the Top Cover*

1. Power down the system as described in section 3.1.
2. Remove the six screws that hold the cover in place.
3. Lift the cover up and off the chassis.

**Caution:** Except for short periods of time, do *not* operate the server without the cover in place. The chassis cover must be in place to allow proper airflow and prevent overheating.

### 3.3 Static-Sensitive Devices

Electrostatic Discharge (ESD) can damage electronic components. To avoid damaging your motherboard, it is important to handle it very carefully. The following measures are generally sufficient to protect the system PCBs from ESD.

#### Precautions

- Use a grounded wrist strap designed to prevent static discharge.
- Touch a grounded metal object before removing any PCB (printed circuit board) from its antistatic bag.
- Handle PCBs by their edges only; do not touch its components, peripheral chips, memory modules or gold contacts.
- When handling chips or modules, avoid touching their pins.
- Put the PCBs back into their antistatic bags when not in use.
- Use only the correct type of onboard CMOS battery. Do not install the onboard battery upside down to avoid possible explosion.

## 3.4 Memory Support and Installation

**Note:** Check the Supermicro website for recommended memory modules.

**Important:** Exercise extreme care when installing or removing DIMM modules to prevent any possible damage.

### Memory Support

The A3SPI-4C-LN6PF/8C-LN6PF motherboard supports up to 128GB of DDR4 ECC RDIMM memory to 2400 MT/s (4C) and 2933 MT/S (8C). Supported sizes are 64GB, 32GB, 16GB, 8GB, 4GB. Populating these DIMM slots with memory modules of the same type and size will result in interleaved memory, which will improve memory performance.

### Memory Population Guidelines

Populate DIMM slots in the following order: DIMMA1, DIMMB1. For optimal memory performance, follow the table below when populating memory.

Recommended Population (Balanced)		
DIMMA1	DIMMB1	Total System Memory
4GB	4GB	8GB
8GB	8GB	16GB
16GB	16GB	32GB
32GB	32GB	64GB
64GB	64GB	128GB

### General Guidelines for Optimizing Memory Performance

- The blue slot must be populated first.
- It is recommended to use DDR4 memory of the same type, size, and speed.
- Mixed DIMM speeds can be installed. However, all DIMMs will run at the speed of the slowest DIMM.
- The motherboard will support odd-numbered modules. However, to achieve the best memory performance, a balanced memory population is recommended.

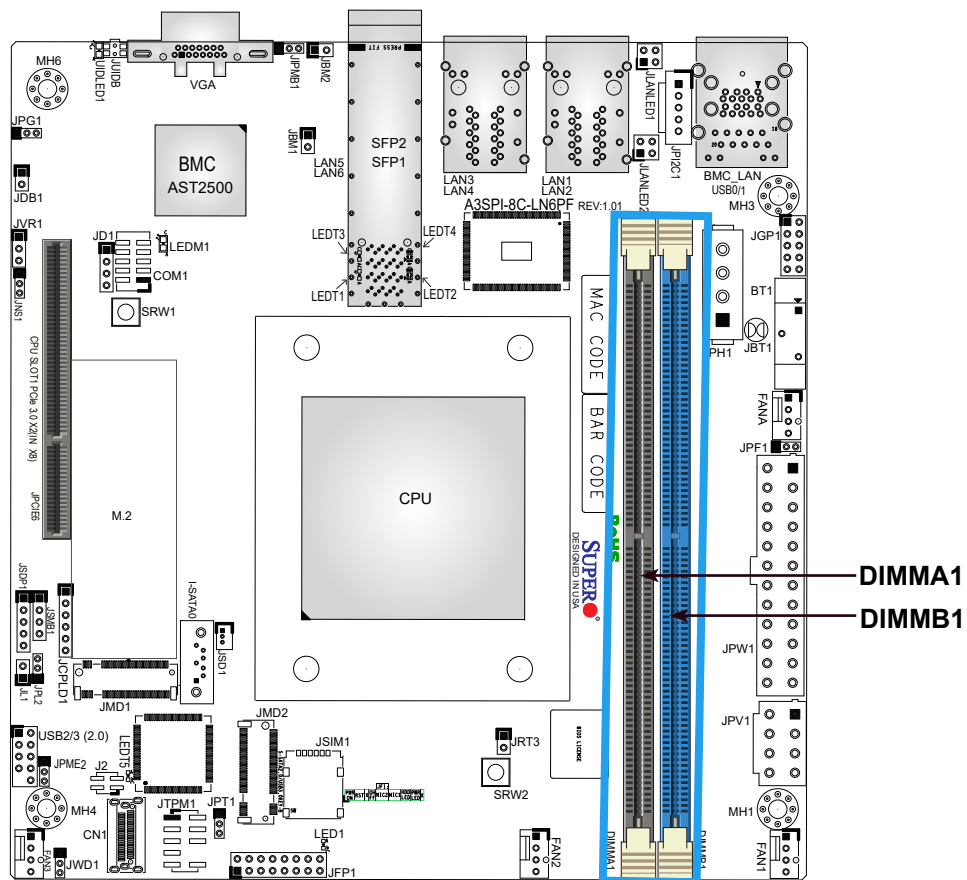

Figure 3-2. Location of DIMM Slots

## Installing Memory

When installing memory modules, the DIMM slots should be populated in the following order: DIMMA1, DIMMB1.

- Always use DDR4 DIMM modules of the same size, type and speed. Mixing memory modules of different types and speeds is not allowed.
- The motherboard will support one DIMM module installed. However, for best memory performance, install DIMM modules in pairs.

**Caution:** Exercise extreme care when installing or removing DIMM modules to prevent damage.

### Installing Memory

Begin by removing power from the system as described in Section 2.1.

1. Starting with P1-DIMMA1, push the release tabs outwards on both ends of the DIMM slot to unlock it.

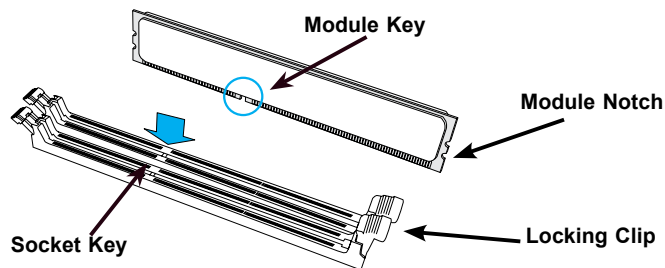

2. Align the key of the DIMM with the receptive point on the memory slot and with your thumbs on both ends of the module, press it straight down into the slot until the module snaps into place.

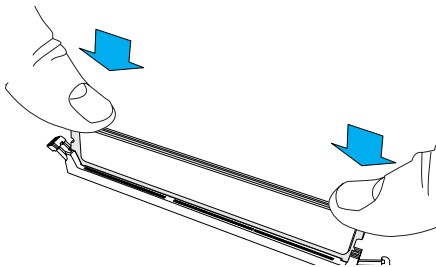

3. Press the release tabs to the locked position to secure the DIMM module into the slot. Repeat for other DIMM slots as needed in the following order:

To remove a DIMM, unlock the release tabs then pull the DIMM from the memory slot.

## Motherboard Battery

The motherboard uses non-volatile memory to retain system information when system power is removed. This memory is powered by a lithium battery residing on the motherboard.

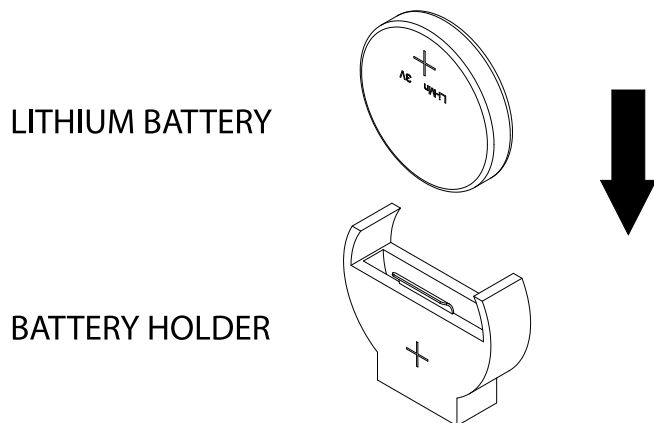

**Figure 3-3. Installing the Onboard Battery**

### *Replacing the Battery*

1. Remove power from the system as described in section 2.1.
2. Push aside the small clamp that covers the edge of the battery. When the battery is released, lift it out of the holder.
3. To insert a new battery, slide one edge under the lip of the holder with the positive (+) side facing up. Then push the other side down until the clamp snaps over it.

**Note:** Handle used batteries carefully. Do not damage the battery in any way; a damaged battery may release hazardous materials into the environment. Do not discard a used battery in the garbage or a public landfill. Please comply with the regulations of your local hazardous waste management agency to dispose of your used battery properly.

**Warning:** There is a danger of explosion if the onboard battery is installed upside down (which reverses its polarities). This battery must be replaced only with the same or an equivalent type recommended by the manufacturer (CR2032).

## 3.5 Chassis Components

### Installing the Storage Drive

The CSE-302iL can accommodate one fixed 2.5" storage drive of 7mm height and one 2.5" drive of 15mm height, installed to a mounting tray inside the chassis.

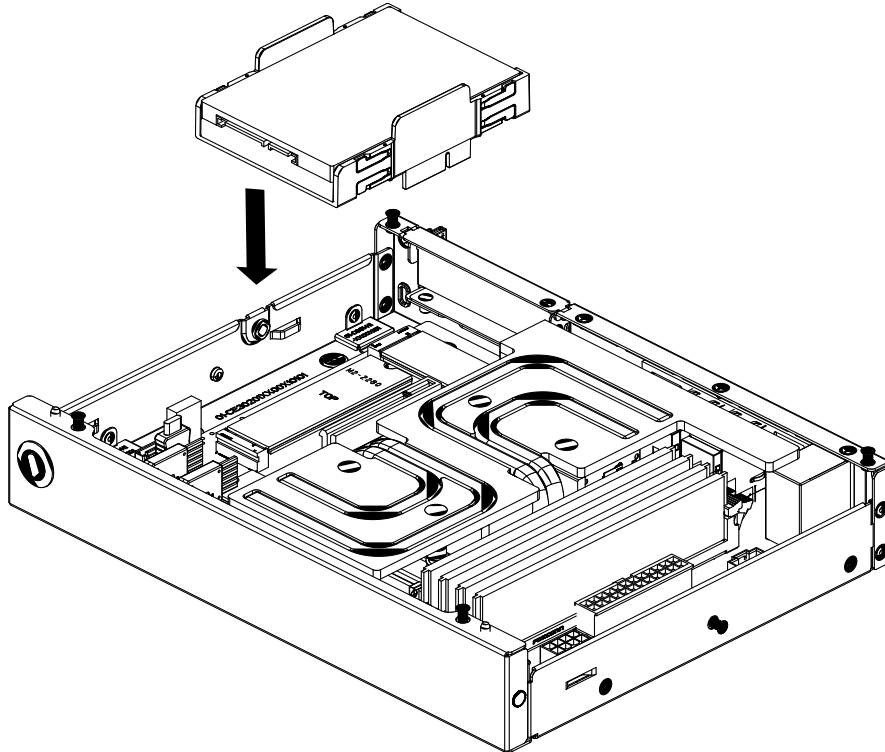
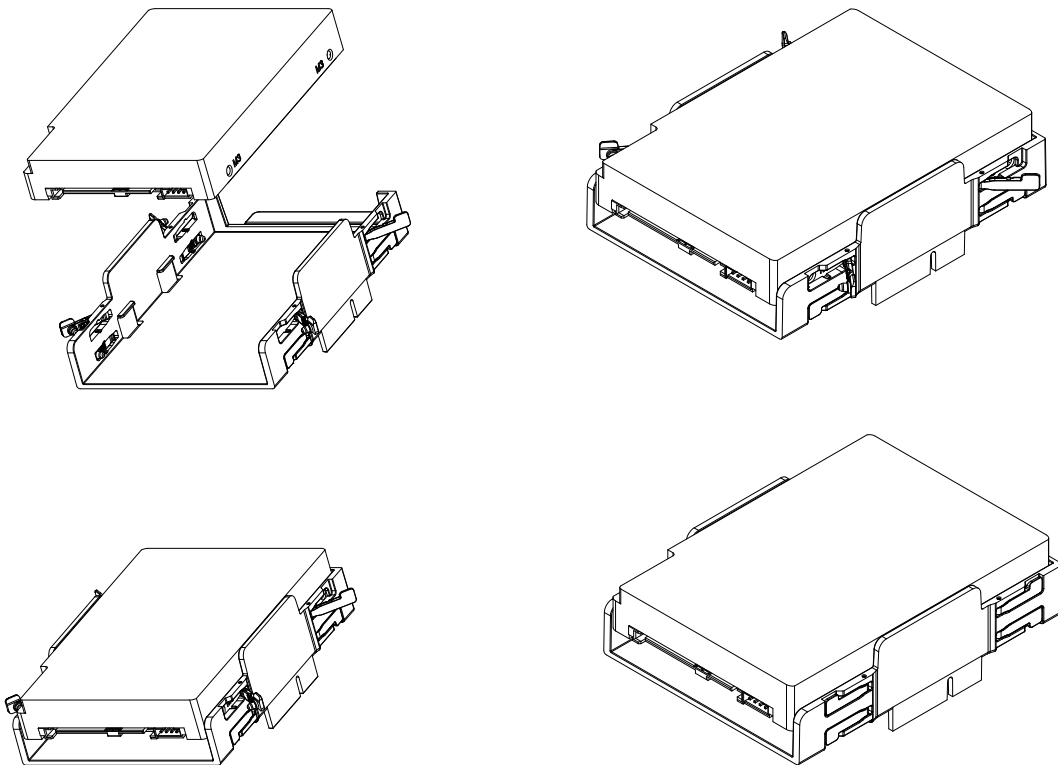

Figure 3-4. Installing the Hard Drive

### ***Installing the Hard Drive***

The motherboard should be installed before installing the drive(s).

1. Make sure there is no power to the system as described in section 3.1 and remove the chassis cover.
2. See section 3.2 for instructions on how to remove the top cover.
3. Lift the hard drive tray from the chassis as shown in Figure 3-4.



**Figure 3-5. Installing a 15mm 2.5" Hard Drive**

4. Place one 15mm 2.5" drive directly into the tray and secure it to the tray with the standoff plugs on the sides of the tray.

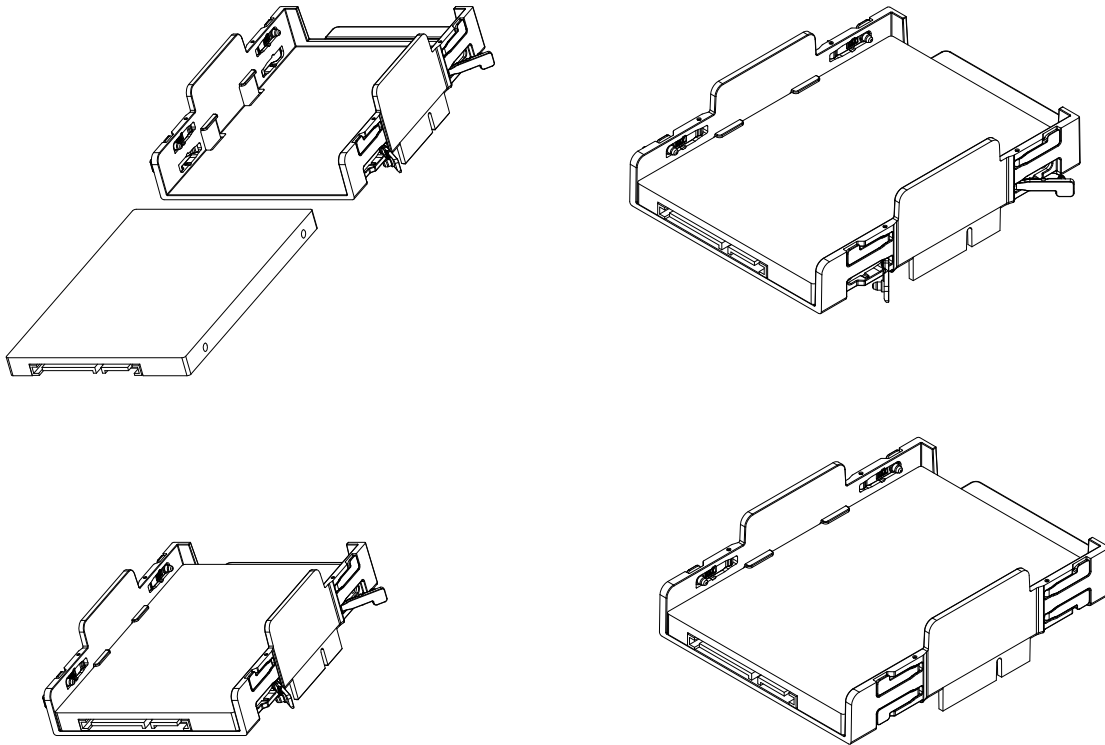

**Figure 3-6. Installing a 7mm 2.5" Hard Drives**

5. Optionally, for a 7mm 2.5" drive, slide it inside the tray first, then secure it to the drive tray with the standoff plugs as shown above.
6. Connect the drive data and power cables.
7. Secure the tray to the chassis by pushing the tray down into the slots.
8. Attach the cables to the appropriate motherboard connector(s).
9. Reinstall the chassis cover and power up the system.

# Chapter 4

## Motherboard Connections

This section describes the connections on the A3SPI-4C-LN6PF/8C-LN6PF motherboard and provides pinout definitions. Note that depending on how the system is configured, not all connections are required. The LEDs on the motherboard are also described here. A motherboard layout indicating component locations may be found in Chapter 1.

Please review the Safety Precautions in Appendix A before installing or removing components.

### 4.1 Power Connections

#### Main ATX Power, 4-pin HDD Power, 4-pin DC Power

The primary power supply connector (JPW1) meets the ATX SSI EPS 24-pin specification. JPH1 is a 4-pin power connector for HDD devices. JPV1 is an 8-pin 12V DC power input for an alternative power source when the 24-pin ATX power is not in use.

ATX Power 24-pin Connector Pin Definitions			
Pin#	Definition	Pin#	Definition
13	+3.3V	1	+3.3V
14	-12V	2	+3.3V
15	COM	3	COM
16	PS_ON	4	+5V
17	COM	5	COM
18	COM	6	+5V
19	COM	7	COM
20	Res (NC)	8	PWR_OK
21	+5V	9	5VSB
22	+5V	10	+12V
23	+5V	11	+12V
24	COM	12	+3.3V

4-pin HDD Power Pin Definitions	
Pin#	Definition
1	12V
2-3	Ground
4	5V

+12V 8-pin Power Pin Definitions	
Pin#	Definition
1-4	Ground
5-8	+12V

## 4.2 Headers and Connectors

### Fan Headers

This motherboard has four 4-pin fan headers. Pins 1-3 of the fan headers are backward compatible with the traditional 3-pin fans, but using 4-pin fans takes advantage of the fan speed control via Pulse Width Modulation through the BMC. This allows the fan speeds to be automatically adjusted based on the motherboard temperature.

Fan Header Pin Definitions	
Pin#	Definition
1	Ground (Black)
2	+12V (Red)
3	Tachometer
4	PWM Control

### Speaker

JD1 is the speaker header. Connect the cable of the external speaker to pins 1-4.

Speaker Connector Pin Definitions	
Pin#	Definition
Pins 1-4	Speaker

### General Purpose I/O Header

JGPI is a 10-pin general purpose I/O header located near the IPMI port. Each pin can be configured to be an input or output pin. The GPIO is controlled via the PCA9554 8-bit GPIO expansion. The base address is 0xEFA0.

JGP1 Header Pin Definitions		
Pin#	Definition	
1	+5V	+5V
2	Ground	Ground
3	GP0	GPP_E0
4	GP1	GPP_F1
5	GP2	GPP_E1
6	GP3	GPP_F2
7	GP4	GPP_E2
8	GP5	GPP_F3
9	GP6	GPP_F0
10	GP7	GPP_F4

### TPM Header

The JTPM1 header is used to connect a Trusted Platform Module (TPM), which is available from Supermicro or a third-party vendor. A TPM is a security device that supports encryption and authentication in hard drives. It enables the motherboard to deny access if the TPM associated with the hard drive is not installed in the system.

More information on TPM is available at: <http://www.supermicro.com/manuals/other/TPM.pdf>

Trusted Platform Module/Port80 Header Pin Definitions			
Pin#	Definition	Pin#	Definition
1	3.3V	2	SPI_CS#
3	RESET#	4	SPI_MISO
5	SPI_CLK#	6	GND
7	SPI_MOSI	8	NC
9	+3.3V Stby	10	SPI_IRQ#

### Chassis Intrusion

A Chassis Intrusion header is located at JL1 on the motherboard. Attach the appropriate cable from the chassis to the header to inform you when the chassis is opened.

Chassis Intrusion Pin Definitions	
Pin#	Definition
1	Intrusion Input
2	Ground

### Power SMB (I<sup>2</sup>C) Header

Power System Management Bus (I<sup>2</sup>C) header at JPI<sup>2</sup>C1 monitors the power supply, fan and system temperatures.

Power SMB Header Pin Definitions	
Pin#	Definition
1	Clock
2	Data
3	Power Fail
4	Ground
5	No Connection

### System Management Bus Header

A System Management Bus header for additional slave devices or sensors is located at JSMB1.

SMBus Header Pin Definitions	
Pin#	Definition
1	Data
2	Ground
3	Clock
4	No Connection

### LAN Port Activity LED Headers

JTGLED1 is the activity header for LAN3 and LAN4.

LAN Activity LED Pin Definitions	
Pin#	Definition
1	3V3 Stby
2	LAN3_ACT_N
3	3V3 Stby
4	LAN4_ACT_N

### Thermal Diode Header

JRT3 is the thermal diode header. This is a thermal sensor header that provides additional system temperature monitoring.

Thermal Diode Pin Definitions	
Pin#	Definition
1	TD1_P
2	TD1_N

### M.2 Slots

The motherboard has two M.2 slots (JMD1 and JMD2). M.2 allows for a variety of card sizes, increased functionality, and spatial efficiency. JMD1 supports an M-Key PCIe 3.0 x4 device in the 2280 form factor, whereas JMD2 supports a B-Key PCIe 3.0 x2/SATA3.0/USB 3.0 device in the 3052 form factor. See pinout tables on the following page.

M.2 Slot Pin Definitions (JMD1 M-Key)			
Pin#	Definition	Pin#	Definition
1	GND	2	P3V3_DUAL
3	USB_JMD2_DP	4	P3V3_DUAL
5	USB_JMD2_DN	6	
7	GND	8	
9		10	
11		12	
13		14	
15		16	
17		18	GND
19		20	UART_BT_WAKE_R_N
21		22	
23		24	
25		26	
27		28	
29		30	
31		32	
33	GND	34	
35	PE_PCH_TX_C_P0	36	
37	PE_PCH_TX_C_N0	38	
39	GND	40	
41	PE_M2E_RX_DP	42	
43	PE_M2E_RX_DN	44	M2E_WLAN_COEX3
45	GND	46	M2E_WLAN_COEX2
47	CLK_100M_M2E_DP	48	M2E_WLAN_COEX1
49	CLK_100M_M2E_DN	50	M2E_SUSCLK_R
51	GND	52	PLTRST_M2E_R
53	CLKREQ_M2E_R_N	54	M2E_W_DISABLE2_N_R
55	PE_WAKE_M2E_R_N	56	M2E_W_DISABLE1_N_R
57	GND	58	M2E_I2C_DAT_R
59		60	M2E_I2C_CLK_R
61		62	
63	GND	64	
65		66	
67		68	
69	GND	70	
71		72	P3V3_DUAL
73		74	P3V3_DUAL
75	GND		

M.2 Slot Pin Definitions (JMD2 B-Key)			
Pin#	Definition	Pin#	Definition
1	NC	2	P3V3SB
3	GND	4	P3V3SB
5	GND	6	FULL_CARD_POWER_OFF#(PU to P1V8SB only)
7	USB_D+	8	W_DISABLE1#(PU to P3V3SB only)
9	USB_D-	10	NC
11	GND	12	
13		14	
15		16	
17		18	
19		20	NC
21	NC	22	NC
23	WWAN_WAKE_N(PU to P1V8SB only)	24	NC
25	NC	26	RF_KILL_GPS_1P8_N(PU to P1V8SB only)
27	GND	28	NC
29	NC	30	NC
31	NC	32	NC
33	GND	34	NC
35	NC	36	NC
37	NC	38	DEVSLP (reserved)
39	GND	40	SMB_CLK (reserved)
41	PERn0/SATARX+	42	SMB_DATA (reserved)
43	PERp0/SATARX-	44	ALERT(PU to P1V8SB only)
45	GND	46	NC
47	PETn0/SATATX-	48	NC
49	PETn0/SATATX+	50	PERST (PLTRST)
51	GND	52	CLK_REQ_N
53	REFCLK-	54	PE_WAKE_N
55	REFCLK+	56	NC
57	GND	58	NC
59	NC	60	NC
61	NC	62	NC
63	NC	64	NC
65	NC	66	NC
67	NC	68	SYSCLK (reserved)
69	PE_DET	70	P3V3SB
71	GND	72	P3V3SB
73	GND	74	P3V3SB
75	NC		

## Control Panel

JFP1 contains header pins for various control panel connections. See the figure below for the pin locations and definitions of the control panel buttons and LED indicators.

All JFP1 wires have been bundled into a single cable to simplify this connection. Make sure the red wire plugs into pin 1 as marked on the motherboard. The other end connects to the control panel PCB board.

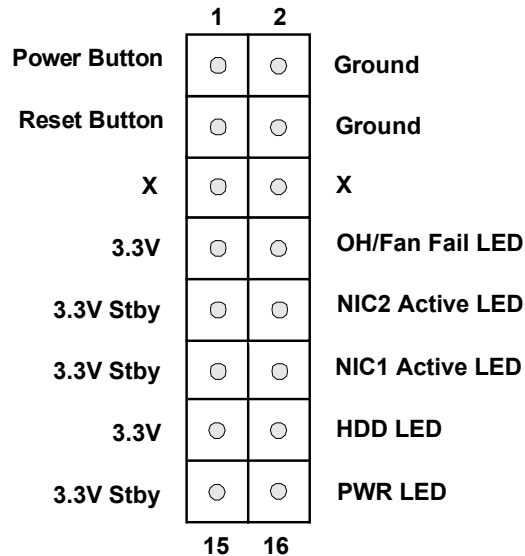

Figure 3-1. JFP1: Control Panel Pins

### Power Button

The Power Button connection is located on pins 1 and 2 of JFP1. Momentarily contacting both pins will power on/off the system. This button can also be configured to function as a suspend button with a setting in the BIOS. To turn off the power when the system is in suspend mode, press the button for 4 seconds or longer.

Power Button Pin Definitions (JFP1)	
Pin#	Definition
1	Signal
2	Ground

### Reset Button

The Reset Button connection is located on pins 3 and 4 of JFP1. Attach it to a hardware reset switch on the computer case.

Reset Button Pin Definitions (JFP1)	
Pin#	Definition
3	Reset
4	Ground

### Overheat (OH)/Fan Fail

Connect an LED cable to pins 7 and 8 of JFP1 (Front Control Panel) to use the Overheat/Fan Fail/Power Fail and UID LED connections. The blue LED on pin 7 works as the front panel UID LED indicator. The red LED on pin 8 provides warnings of overheating, fan failure or power failure. The red LED takes precedence over the blue LED by default.

OH/Fan Fail/PWR Fail/UID LED Pin Definitions (JFP1)	
Pin#	Definition
7	Blue LED
8	OH/Fan Fail/Pwr Fail

Indicator Status	
Status	Definition
Off	Normal
On	Overheat
Flashing	Fan or power fail

### NIC1/NIC2 (LAN1/LAN2)

The NIC (Network Interface Controller) LED connection for LAN port 1 is located on pins 11 and 12 of JFP1, and the LED connection for LAN Port 2 is on pins 9 and 10. Attach the NIC LED cables here to display network activity.

LAN1/LAN2 LED Pin Definitions (JFP1)	
Pin#	Definition
9	NIC2 Activity LED
10	NIC2 Link LED
11	NIC1 Activity LED
12	NIC1 Link LED

### HDD LED

The HDD LED connection is located on pins 13 and 14 of JFP1. Attach a cable here to indicate the status of HDD-related activities, including SATA activities.

HDD LED Pin Definitions (JFP1)	
Pin#	Definition
13	3.3V Standby/UID Switch
14	HDD Active

### Power LED

The Power LED connection is located on pins 15 and 16 of JFP1.

Power LED Pin Definitions (JFP1)	
Pin#	Definition
15	3.3V
16	Power LED

## 4.3 Ports

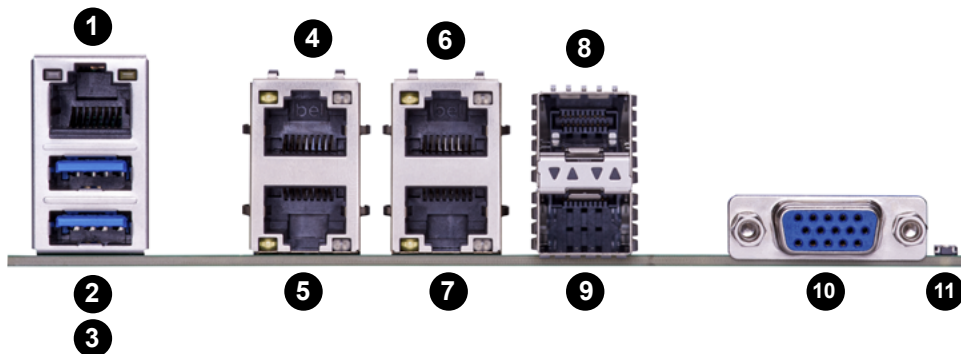

Rear I/O Ports					
#	Description	#	Description	#	Description
1	BMC_LAN	5	LAN1 (Share NIC) (RJ45 GbE)	9	LAN5 (SFP+ 10GbE)
2	USB1	6	LAN4 (RJ45 GbE)	10	VGA
3	USB0	7	LAN3 (RJ45 GbE)	11	UID Switch
4	LAN2	8	LAN6 (SFP+ 10GbE)		

### Ethernet Ports (GbE)

Four Gigabit Ethernet ports (LAN1–4) and an IPMI LAN port provide network connections. These ports accept RJ45 type cables.

### Ethernet Ports (10GbE)

Two 10 Gigabit SFP+ Ethernet ports (LAN5–6) are also provided on the rear of the motherboard.

### Universal Serial Bus (USB) Ports

Two USB 3.0 ports (USB0/1) are located on the I/O back panel.

### VGA Port

A video (VGA) port is located on the I/O back panel. Refer to the board layout below for the location.

### Unit Identifier Switch/UID LED Indicator

A Unit Identifier (UID) switch and an LED Indicator are located on the motherboard. The UID switch is located at JUIDB1 on the back panel. The UID LED (UIDLED1) is located next to the UID switch. When you press the UID switch, the UID LED will be turned on. Press the UID switch again to turn off the LED indicator. The UID Indicator provides easy identification of a system unit that may be in need of service.

**Note:** UID can also be triggered via IPMI on the motherboard. For more information on IPMI, please refer to the IPMI User's Guide posted on our website at <https://www.supermicro.com/support/manuals/>.

UID Switch Pin Definitions	
Pin#	Definition
1	Ground
2	Ground
3	Button In
4	Button In

UID LED Pin Definitions	
Color	Status
Blue: On	Unit Identified

## 4.4 Jumpers

### Explanation of Jumpers

To modify the operation of the motherboard, jumpers are used to choose between optional settings. Jumpers create shorts between two pins to change the function associated with it. Pin 1 is identified with a square solder pad on the printed circuit board. See the motherboard layout page for jumper locations.

**Note:** On a two-pin jumper, "Closed" means the jumper is on both pins and "Open" indicates the jumper is either on only one pin or has been completely removed.

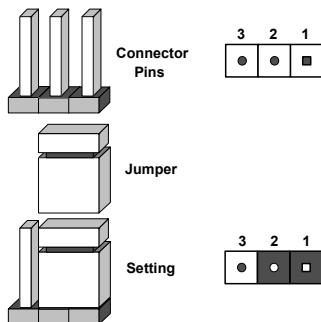

### CMOS Clear

JBT1 is used to clear CMOS, which will also clear any passwords. Instead of pins, this jumper consists of contact pads to prevent accidentally clearing the contents of CMOS.

#### To Clear CMOS

1. First power down the system and unplug the power cord(s).
2. Remove the cover of the chassis to access the motherboard.
3. Remove the onboard battery from the motherboard.
4. Short the CMOS pads with a metal object such as a small screwdriver for at least four seconds.
5. Remove the screwdriver (or shorting device).
6. Replace the cover, reconnect the power cord(s) and power on the system.



**Notes:** Clearing CMOS will also clear all passwords.

Do not use the PW\_ON connector to clear CMOS.

### VGA Enable/Disable

Jumper JPG1 allows you to enable or disable the VGA port using the onboard graphics controller. The default setting is Enabled.

VGA Enable/Disable Jumper Settings	
Jumper Setting	Definition
Pins 1-2	Enabled (Default)
Pins 2-3	Disabled

### ME Manufacturing Mode Select

Close JPME2 to bypass SPI flash security and force the system to use the Manufacturing Mode, which will allow you to flash the system firmware from a host server to modify system settings. Refer the table below for jumper settings.

ME Manufacturing Mode Jumper Settings	
Jumper Setting	Definition
Pins 1-2	Normal (Default)
Pins 2-3	Manufacturing Mode

### Watch Dog

JWD1 controls the Watch Dog function. Watch Dog is a monitor that can reboot the system when a software application hangs. Jumping pins 1-2 will cause Watch Dog to reset the system if an application hangs. Jumping pins 2-3 will generate a non-maskable interrupt signal for the application that hangs. Watch Dog must also be enabled in BIOS. The default setting is Reset.

**Note:** When Watch Dog is enabled, users must write their own application software to disable it.

Watch Dog Jumper Settings	
Jumper Setting	Definition
Pins 1-2	Reset (Default)
Pins 2-3	NMI
Open	Disabled

**ATX/Force PS-ON Mode Select**

Use jumper JPF1 to select ATX or Force PS-ON Mode (default). Refer to the table below for pin definitions.

<b>ATX/Force PS-ON Mode Jumper Settings</b>	
<b>Jumper Setting</b>	<b>Definition</b>
Pins 1-2	ATX Mode
Pins 2-3	Force PS-ON Mode

**IPMI Shared LAN Enable/Disable**

Set the JBM1 jumper to enabled to share LAN1 with IPMI.

<b>IPMI Share LAN Enable/Disable Jumper Settings</b>	
<b>Jumper Setting</b>	<b>Definition</b>
Pins 1-2 (Open)	Enabled (Default)
Pins 1-2 (Short)	Disabled

## 4.5 LED Indicators

### LAN LEDs

Each Ethernet port on the I/O back panel has two LEDs. One LED indicates activity when flashing, while the other (Link) LED may be green, amber or off to indicate the speed of the connection.

1GbE LAN LEDs (Connection Speed Indicator)	
LED Color	Definition
Off	No connection or 10 Mb/s
Green	100 Mb/s
Orange	1 Gb/s



### Dedicated IPMI LAN LEDs

A dedicated IPMI LAN is also included on the motherboard. The amber LED on the right of the IPMI LAN port indicates activity, while the green LED (Link) on the left indicates the speed of the connection.

IPMI LAN LEDs		
Color	Status	Definition
Off	Off	No Connection
Green	Link/Speed	100 Mb/s



### Onboard Power LED

LED1 is an Onboard Power LED. When this LED is lit, it means power is present on the motherboard. In suspend mode, this LED will blink on and off. Be sure to turn off the system and unplug the power cord(s) before removing or installing components.

Onboard Power LED Indicator	
LED Color	Definition
Off	System Off (power cable not connected)
Green	System On

### BMC Heartbeat LED

LEDM1 is the BMC heartbeat LED. When the LED is blinking green, BMC is functioning normally.

# Chapter 5

## Software

After the hardware has been installed, you can install the Operating System (OS), configure RAID settings and install the drivers.

### 5.1 SuperDoctor® 5

The Supermicro SuperDoctor 5 is a program that functions in a command-line or web-based interface for Windows and Linux operating systems. The program monitors such system health information as CPU temperature, system voltages, system power consumption, fan speed, and provides alerts via email or Simple Network Management Protocol (SNMP).

SuperDoctor 5 comes in local and remote management versions and can be used with Nagios to maximize your system monitoring needs. With SuperDoctor 5 Management Server (SSM Server), you can remotely control power on/off and reset chassis intrusion for multiple systems with SuperDoctor 5 or BMC. SuperDoctor 5 Management Server monitors HTTP, FTP, and SMTP services to optimize the efficiency of your operation.

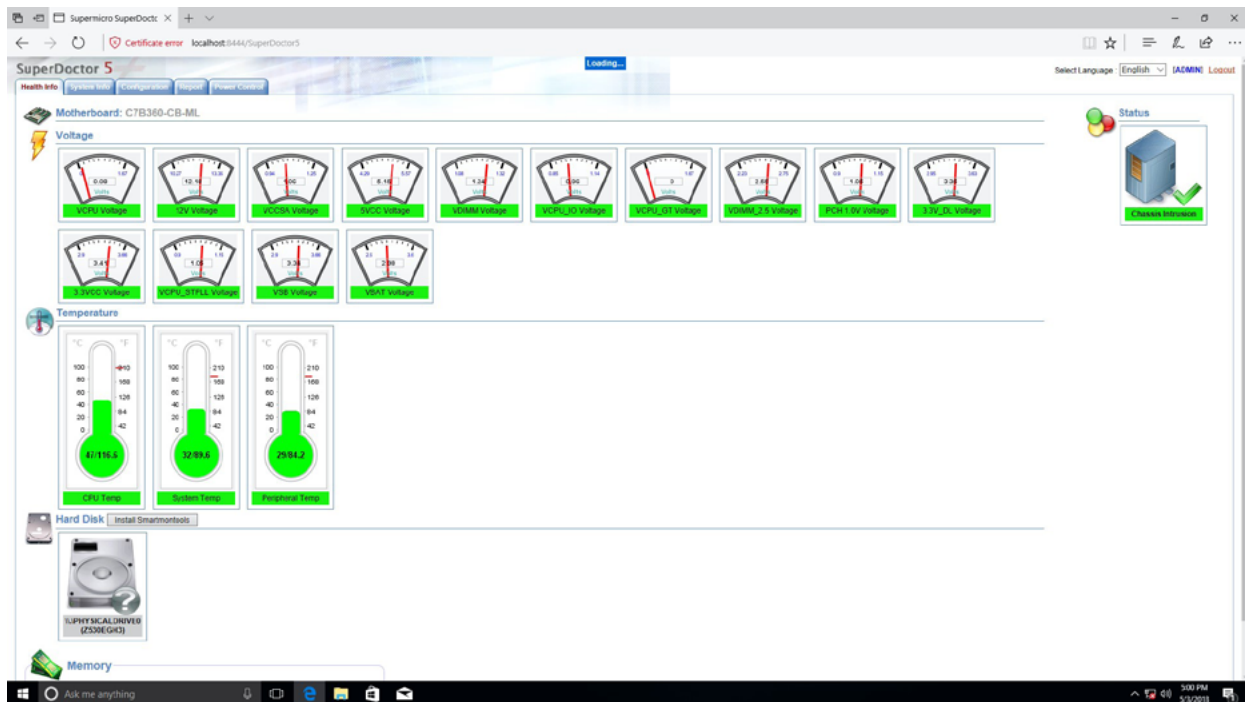

Figure 5-1. SuperDoctor 5 Interface Display Screen (Health Information)

## 5.2 BMC

The A3SPI-4C-LN6PF/8C-LN6PF provides remote access, monitoring and management through the baseboard management controller (BMC) and other management controllers distributed among different system modules. There are several BIOS settings that are related to BMC. For general documentation and information on BMC, visit our website at:

[www.supermicro.com/en/solutions/management-software/bmc-resources](http://www.supermicro.com/en/solutions/management-software/bmc-resources)

### BMC ADMIN User Password

For security, each system is assigned a unique default BMC password for the ADMIN user. This can be found on a sticker on the chassis and a sticker on the motherboard. The sticker also displays the BMC MAC address.



Figure 5-2. BMC Password Label

See [Chapter 1](#) for label location.

## Appendix A

# Standardized Warning Statements for AC Systems

## About Standardized Warning Statements

The following statements are industry standard warnings, provided to warn the user of situations which have the potential for bodily injury. Should you have questions or experience difficulty, contact Supermicro's Technical Support department for assistance. Only certified technicians should attempt to install or configure components.

Read this appendix in its entirety before installing or configuring components in the Supermicro chassis.

These warnings may also be found on our website at [http://www.supermicro.com/about/policies/safety\\_information.cfm](http://www.supermicro.com/about/policies/safety_information.cfm).

## Warning Definition



**Warning!** This warning symbol means danger. You are in a situation that could cause bodily injury. Before you work on any equipment, be aware of the hazards involved with electrical circuitry and be familiar with standard practices for preventing accidents.

### 警告の定義

この警告サインは危険を意味します。

人身事故につながる可能性がありますので、いずれの機器でも動作させる前に、電気回路に含まれる危険性に注意して、標準的な事故防止策に精通して下さい。

此警告符号代表危險。

您正处于可能受到严重伤害的工作环境中。在您使用设备开始工作之前，必须充分意识到触电的危险，并熟练掌握防止事故发生的标准工作程序。请根据每项警告结尾的声明号码找到此设备的安全性警告说明的翻译文本。

此警告符號代表危險。

您正處於可能身體可能會受損傷的工作環境中。在您使用任何設備之前，請注意觸電的危險，並且要熟悉預防事故發生的標準工作程序。請依照每一注意事項後的號碼找到相關的翻譯說明內容。

## Warnung

### WICHTIGE SICHERHEITSHINWEISE

Dieses Warnsymbol bedeutet Gefahr. Sie befinden sich in einer Situation, die zu Verletzungen führen kann. Machen Sie sich vor der Arbeit mit Geräten mit den Gefahren elektrischer Schaltungen und den üblichen Verfahren zur Vorbeugung vor Unfällen vertraut. Suchen Sie mit der am Ende jeder Warnung angegebenen Anweisungsnummer nach der jeweiligen Übersetzung in den übersetzten Sicherheitshinweisen, die zusammen mit diesem Gerät ausgeliefert wurden.

BEWAHREN SIE DIESE HINWEISE GUT AUF.

### INSTRUCCIONES IMPORTANTES DE SEGURIDAD

Este símbolo de aviso indica peligro. Existe riesgo para su integridad física. Antes de manipular cualquier equipo, considere los riesgos de la corriente eléctrica y familiarícese con los procedimientos estándar de prevención de accidentes. Al final de cada advertencia encontrará el número que le ayudará a encontrar el texto traducido en el apartado de traducciones que acompaña a este dispositivo.

GUARDE ESTAS INSTRUCCIONES.

### IMPORTANTES INFORMATIONS DE SÉCURITÉ

Ce symbole d'avertissement indique un danger. Vous vous trouvez dans une situation pouvant entraîner des blessures ou des dommages corporels. Avant de travailler sur un équipement, soyez conscient des dangers liés aux circuits électriques et familiarisez-vous avec les procédures couramment utilisées pour éviter les accidents. Pour prendre connaissance des traductions des avertissements figurant dans les consignes de sécurité traduites qui accompagnent cet appareil, référez-vous au numéro de l'instruction situé à la fin de chaque avertissement.

CONSERVEZ CES INFORMATIONS.

## תקנון הזהרות אזהרה

הזהרות הבאות הן אזהרות על פי תקני התעשייה, על מנת להזהיר את המשתמש מפני חבלה פיזית אפשרית. במידה ויש שאלות או היתקלות בבעיה כלשהי, יש ליצור קשר עם מחלקת תמיכה טכנית של סופרמיקרו. טכנאים מוסמכים בלבד רשאים להתקין או להגדיר את הרכיבים. יש לקרוא את הנספח במלואו לפני התקנת או הגדרת הרכיבים במארזי סופרמיקרו.

اَكْ ف حالة وُكِي اَي تتسبب ف اصابة جسدهُ هذا الزهز عْ خطر! تحذُرُ .  
 قبل اَي تعول على اَي هعدات، كي على علن بالوخاطز ال اُجوة عي الذوائر  
 الكهزبائِة  
 وكي على دراةُ بالووارسات النقااِة لو عْ وقع اَي حادث  
 استخدم رقن الب اِى الو صُص ف هاةُ كل تحذُرُ للعشر تزجوتها

안전을 위한 주의사항

경고!

이 경고 기호는 위험이 있음을 알려 줍니다. 작업자의 신체에 부상을 야기 할 수 있는 상태에 있게 됩니다. 모든 장비에 대한 작업을 수행하기 전에 전기회로와 관련된 위험요소들을 확인하시고 사전에 사고를 방지할 수 있도록 표준 작업절차를 준수해 주시기 바랍니다.

해당 번역문을 찾기 위해 각 경고의 마지막 부분에 제공된 경고문 번호를 참조하십시오

## BELANGRIJKE VEILIGHEIDSINSTRUCTIES

Dit waarschuwings symbool betekent gevaar. U verkeert in een situatie die lichamelijk letsel kan veroorzaken. Voordat u aan enige apparatuur gaat werken, dient u zich bewust te zijn van de bij een elektrische installatie betrokken risico's en dient u op de hoogte te zijn van de standaard procedures om ongelukken te voorkomen. Gebruik de nummers aan het eind van elke waarschuwing om deze te herleiden naar de desbetreffende locatie.

BEWAAR DEZE INSTRUCTIES

## Installation Instructions



**Warning!** Read the installation instructions before connecting the system to the power source.

設置手順書

システムを電源に接続する前に、設置手順書をお読み下さい。

警告

将此系统连接电源前,请先阅读安装说明。

警告

將系統與電源連接前，請先閱讀安裝說明。

**Warnung**

Vor dem Anschließen des Systems an die Stromquelle die Installationsanweisungen lesen.

**¡Advertencia!**

Lea las instrucciones de instalación antes de conectar el sistema a la red de alimentación.

**Attention**

Avant de brancher le système sur la source d'alimentation, consulter les directives d'installation.

יש לקרוא את הוראות התקנה לפני חיבור המערכת למקור מתח.

اقر إرشادات التركيب قبل توصيل النظام إلى مصدر للطاقة

시스템을 전원에 연결하기 전에 설치 안내를 읽어주십시오.

**Waarschuwing**

Raadpleeg de installatie-instructies voordat u het systeem op de voedingsbron aansluit.

**Circuit Breaker**

**Warning!** This product relies on the building's installation for short-circuit (overcurrent) protection. Ensure that the protective device is rated not greater than: 250 V, 20 A.

**サーキット・ブレーカー**

この製品は、短絡(過電流)保護装置がある建物での設置を前提としています。

保護装置の定格が250 V、20 Aを超えないことを確認下さい。

**警告**

此产品的短路(过载电流)保护由建筑物的供电系统提供,确保短路保护设备的额定电流不大于250V,20A。

**警告**

此產品的短路(過載電流)保護由建築物的供電系統提供,確保短路保護設備的額定電流不大於250V,20A。

**Warnung**

Dieses Produkt ist darauf angewiesen, dass im Gebäude ein Kurzschluss- bzw. Überstromschutz installiert ist. Stellen Sie sicher, dass der Nennwert der Schutzvorrichtung nicht mehr als: 250 V, 20 A beträgt.

**¡Advertencia!**

Este equipo utiliza el sistema de protección contra cortocircuitos (o sobrecorrientes) del edificio. Asegúrese de que el dispositivo de protección no sea superior a: 250 V, 20 A.

**Attention**

Pour ce qui est de la protection contre les courts-circuits (surtension), ce produit dépend de l'installation électrique du local. Vérifiez que le courant nominal du dispositif de protection n'est pas supérieur à :250 V, 20 A.

מוצר זה מסתמך על הגנה המותקנת במבנים למניעת קצר חשמלי. יש לוודא כי המכשיר המגן מפני הקצר החשמלי הוא לא יותר מ-250VDC, 20A

هذا المنتج يعتمد على معدات الحماية مه الدوائر القصيرة التي تم تثبيتها في المبنى  
تأكد من أن تقييم الجهاز الوقائي ليس أكثر من : 20A, 250V

**경고!**

이 제품은 전원의 단락(과전류)방지에 대해서 전적으로 건물의 관련 설비에 의존합니다. 보호장치의 정격이 반드시 250V(볼트), 20A(암페어)를 초과하지 않도록 해야 합니다.

**Waarschuwing**

Dit product is afhankelijk van de kortsluitbeveiliging (overspanning) van uw elektrische installatie. Controleer of het beveiligde apparaat niet groter gedimensioneerd is dan 250V, 20A.

## Power Disconnection Warning



**Warning!** The system must be disconnected from all sources of power and the power cord removed from the power supply module(s) before accessing the chassis interior to install or remove system components.



### 電源切断の警告

システムコンポーネントの取り付けまたは取り外しのために、シャーシ内部にアクセスするには、システムの電源はすべてのソースから切断され、電源コードは電源モジュールから取り外す必要があります。

### 警告

在你打开机箱并安装或移除内部器件前,必须将系统完全断电,并移除电源线。

### 警告

在您打開機殼安裝或移除內部元件前，必須將系統完全斷電，並移除電源線。

### Warnung

Das System muss von allen Quellen der Energie und vom Netzanschlusskabel getrennt sein, das von den Spg.Versorgungsteilmodulen entfernt wird, bevor es auf den Chassisinnenraum zurückgreift, um Systemsbestandteile anzubringen oder zu entfernen.

### ¡Advertencia!

El sistema debe ser disconnected de todas las fuentes de energía y del cable eléctrico quitado de los módulos de fuente de alimentación antes de tener acceso el interior del chasis para instalar o para quitar componentes de sistema.

### Attention

Le système doit être débranché de toutes les sources de puissance ainsi que de son cordon d'alimentation secteur avant d'accéder à l'intérieur du chassis pour installer ou enlever des composants de système.

אזהרה מפני ניתוק חשמלי

אזהרה!

יש לנתק את המערכת מכל מקורות החשמל ויש להסיר את כבל החשמלי מהספק לפני גישה לחלק הפנימי של המארז לצורך התקנת או הסרת רכיבים.

يجب فصل انظاؤ من جميع مصادر انطاقت وإزانت سهك انكهرباء من وحدة امداد انطاقت قېم

انصل إلى امناطق انداخييت نههيكم نثبيح أو إزانت مكناث الجهاز

경고!

시스템에 부품들을 장착하거나 제거하기 위해서는 새시 내부에 접근하기 전에 반드시 전원 공급장치로부터 연결되어있는 모든 전원과 전기코드를 분리해주어야 합니다.

Waarschuwing

Voordat u toegang neemt tot het binnenwerk van de behuizing voor het installeren of verwijderen van systeem onderdelen, dient u alle spanningsbronnen en alle stroomkabels aangesloten op de voeding(en) van de behuizing te verwijderen

## Equipment Installation



**Warning!** Only trained and qualified personnel should be allowed to install, replace, or service this equipment.

機器の設置

トレーニングを受け認定された人だけがこの装置の設置、交換、またはサービスを許可されていません。

警告

只有经过培训且具有资格的人员才能进行此设备的安装、更换和维修。

警告

只有經過受訓且具資格人員才可安裝、更換與維修此設備。

Warnung

Das Installieren, Ersetzen oder Bedienen dieser Ausrüstung sollte nur geschultem, qualifiziertem Personal gestattet werden.

¡Advertencia!

Solamente el personal calificado debe instalar, reemplazar o utilizar este equipo.

**Attention**

Il est vivement recommandé de confier l'installation, le remplacement et la maintenance de ces équipements à des personnels qualifiés et expérimentés.

אזהרה!

צוות מוסמך בלבד רשאי להתקין, להחליף את הציוד או לתת שירות עבור הציוד.

والمدربيه لتزكيب واستبدال أو خدمة هذا الجهاز يجب أن يسمح فقط للمظفيه المؤهليه

경고!

훈련을 받고 공인된 기술자만이 이 장비의 설치, 교체 또는 서비스를 수행할 수 있습니다.

**Waarschuwing**

Deze apparatuur mag alleen worden geïnstalleerd, vervangen of hersteld door geschoold en gekwalificeerd personeel.

**Restricted Area**

**Warning!** This unit is intended for installation in restricted access areas. A restricted access area can be accessed only through the use of a special tool, lock and key, or other means of security. (This warning does not apply to workstations).

**アクセス制限区域**

このユニットは、アクセス制限区域に設置されることを想定しています。

アクセス制限区域は、特別なツール、鍵と錠前、その他のセキュリティの手段を用いてのみ出入りが可能です。

**警告**

此部件应安装在限制进出的场所，限制进出的场所指只能通过使用特殊工具、锁和钥匙或其它安全手段进出的场所。

**警告**

此装置仅限安装於進出管制區域，進出管制區域係指僅能以特殊工具、鎖頭及鑰匙或其他安全方式才能進入的區域。

**Warnung**

Diese Einheit ist zur Installation in Bereichen mit beschränktem Zutritt vorgesehen. Der Zutritt zu derartigen Bereichen ist nur mit einem Spezialwerkzeug, Schloss und Schlüssel oder einer sonstigen Sicherheitsvorkehrung möglich.

**¡Advertencia!**

Esta unidad ha sido diseñada para instalación en áreas de acceso restringido. Sólo puede obtenerse acceso a una de estas áreas mediante la utilización de una herramienta especial, cerradura con llave u otro medio de seguridad.

**Attention**

Cet appareil doit être installée dans des zones d'accès réservés. L'accès à une zone d'accès réservé n'est possible qu'en utilisant un outil spécial, un mécanisme de verrouillage et une clé, ou tout autre moyen de sécurité.

אזור עם גישה מוגבלת

אזהרה!

יש להתקין את היחידה באזורים שיש בהם הגבלת גישה. הגישה ניתנת בעזרת 'כלי אבטחה בלבד' (מפתח, מנעול וכד.).

تخصيص هذه انحدة نترك بها ف مناطق محظورة تم .  
ممكن انصلل إن منطقت محظورة فقط من خلال استخذاو أداة خاصت  
أو أ وس هُت أخري نلالأمما ققم ومفتاح

**경고!**

이 장치는 접근이 제한된 구역에 설치하도록 되어있습니다. 특수도구, 잠금 장치 및 키, 또는 기타 보안 수단을 통해서만 접근 제한 구역에 들어갈 수 있습니다.

**Waarschuwing**

Dit apparaat is bedoeld voor installatie in gebieden met een beperkte toegang. Toegang tot dergelijke gebieden kunnen alleen verkregen worden door gebruik te maken van speciaal gereedschap, slot en sleutel of andere veiligheidsmaatregelen.

## Battery Handling



**Warning!** There is the danger of explosion if the battery is replaced incorrectly. Replace the battery only with the same or equivalent type recommended by the manufacturer. Dispose of used batteries according to the manufacturer's instructions

### 電池の取り扱い

電池交換が正しく行われなかった場合、破裂の危険性があります。交換する電池はメーカーが推奨する型、または同等のものを使用下さい。使用済電池は製造元の指示に従って処分して下さい。

### 警告

電池更換不當會有爆炸危險。請只使用同類電池或制造商推荐的功能相当的電池更換原有電池。請按制造商的說明處理廢舊電池。

### 警告

電池更換不當會有爆炸危險。請使用製造商建議之相同或功能相當的電池更換原有電池。請按照製造商的說明指示處理廢棄舊電池。

### Warnung

Bei Einsetzen einer falschen Batterie besteht Explosionsgefahr. Ersetzen Sie die Batterie nur durch den gleichen oder vom Hersteller empfohlenen Batterietyp. Entsorgen Sie die benutzten Batterien nach den Anweisungen des Herstellers.

### Attention

Danger d'explosion si la pile n'est pas remplacée correctement. Ne la remplacer que par une pile de type semblable ou équivalent, recommandée par le fabricant. Jeter les piles usagées conformément aux instructions du fabricant.

### ¡Advertencia!

Existe peligro de explosión si la batería se reemplaza de manera incorrecta. Reemplazar la batería exclusivamente con el mismo tipo o el equivalente recomendado por el fabricante. Desechar las baterías gastadas según las instrucciones del fabricante.

### אזהרה!

קיימת סכנת פיצוץ של הסוללה במידה והוחלפה בדרך לא תקינה. יש להחליף את הסוללה בסוג התואם מחברת יצרן מומלצת. סילוק הסוללות המשומשות יש לבצע לפי הוראות היצרן.

هناك خطر من انفجار في حالة اسبدال البطارية بطريقة غير صحيحة فعلى  
اسبدال البطارية  
فقط بنفس النوع أو ما يعادلها مما أوصت به الشركة المصنعة  
جخلص من البطاريات المسحومة وفقا لعمليات الشركة الصانعة

경고!

배터리가 올바르게 교체되지 않으면 폭발의 위험이 있습니다. 기존 배터리와 동일하거나 제조사에서 권장하는 동등한 종류의 배터리로만 교체해야 합니다. 제조사의 안내에 따라 사용된 배터리를 처리하여 주십시오.

Waarschuwing

Er is ontplofingsgevaar indien de batterij verkeerd vervangen wordt. Vervang de batterij slechts met hetzelfde of een equivalent type die door de fabrikant aanbevolen wordt. Gebruikte batterijen dienen overeenkomstig fabrieksvoorschriften afgevoerd te worden.

## Redundant Power Supplies



**Warning!** This unit might have more than one power supply connection. All connections must be removed to de-energize the unit.

冗長電源装置

このユニットは複数の電源装置が接続されている場合があります。

ユニットの電源を切るためには、すべての接続を取り外さなければなりません。

警告

此部件连接的电源可能不止一个，必须将所有电源断开才能停止给该部件供电。

警告

此装置连接的电源可能不只一个，必须切断所有电源才能停止对该装置的供电。

Warnung

Dieses Gerät kann mehr als eine Stromzufuhr haben. Um sicherzustellen, dass der Einheit kein Strom zugeführt wird, müssen alle Verbindungen entfernt werden.

¡Advertencia!

Puede que esta unidad tenga más de una conexión para fuentes de alimentación. Para cortar por completo el suministro de energía, deben desconectarse todas las conexiones.

Attention

Cette unité peut avoir plus d'une connexion d'alimentation. Pour supprimer toute tension et tout courant électrique de l'unité, toutes les connexions d'alimentation doivent être débranchées.

אם קיים יותר מספק אחד

אזהרה!

ליחידה יש יותר מחיבור אחד של ספק. יש להסיר את כל החיבורים על מנת לרוקן את היחידה.

قد يكون لهذا الجهاز عدة اتصالات بوحدات امداد الطاقة .

يجب إزالة كافة الاتصالات لعسل الوحدة عن الكهرباء

경고!

이 장치에는 한 개 이상의 전원 공급 단자가 연결되어 있을 수 있습니다. 이 장치에 전원을 차단하기 위해서는 모든 연결 단자를 제거해야만 합니다.

Waarschuwing

Deze eenheid kan meer dan één stroomtoevoeraansluiting bevatten. Alle aansluitingen dienen verwijderd te worden om het apparaat stroomloos te maken.

## Backplane Voltage



**Warning!** Hazardous voltage or energy is present on the backplane when the system is operating. Use caution when servicing.

バックプレーンの電圧

システムの稼働中は危険な電圧または電力が、バックプレーン上にかかっています。

修理する際には注意ください。

警告

当系统正在进行时，背板上有很危险的电压或能量，进行维修时务必小心。

警告

當系統正在進行時，背板上有危險的電壓或能量，進行維修時務必小心。

Warnung

Wenn das System in Betrieb ist, treten auf der Rückwandplatine gefährliche Spannungen oder Energien auf. Vorsicht bei der Wartung.

¡Advertencia!

Cuando el sistema está en funcionamiento, el voltaje del plano trasero es peligroso. Tenga cuidado cuando lo revise.

Attention

Lorsque le système est en fonctionnement, des tensions électriques circulent sur le fond de panier. Prendre des précautions lors de la maintenance.

מתח בפנל האחורי

אזהרה!

קיימת סכנת מתח בפנל האחורי בזמן תפעול המערכת. יש להיזהר במהלך העבודה.

هناك خطر من التيار الكهربائي أو الطاقة المتجددة على اللوحة  
عندما يكون النظام يعمل كه حذرا عند خدمة هذا الجهاز

경고!

시스템이 동작 중일 때 후면판 (Backplane)에는 위험한 전압이나 에너지가 발생 합니다.  
서비스 작업 시 주의하십시오.

Waarschuwing

Een gevaarlijke spanning of energie is aanwezig op de backplane wanneer het systeem in gebruik is. Voorzichtigheid is geboden tijdens het onderhoud.

## Comply with Local and National Electrical Codes



**Warning!** Installation of the equipment must comply with local and national electrical codes.

地方および国の電気規格に準拠

機器の取り付けはその地方および国の電気規格に準拠する必要があります。

警告

设备安装必须符合本地与本国电气法规。

警告

設備安裝必須符合本地與本國電氣法規。

Warnung

Die Installation der Geräte muss den Sicherheitsstandards entsprechen.

¡Advertencia!

La instalación del equipo debe cumplir con las normas de electricidad locales y nacionales.

Attention

L'équipement doit être installé conformément aux normes électriques nationales et locales.

תיאום חוקי החשמל הארצי  
אזהרה!  
התקנת הציוד חייבת להיות תואמת לחוקי החשמל המקומיים והארציים.

تركيب المعدات الكهربائية يجب أن يمتثل للقوايه المحلية والبطية المتعلقة  
بالكهرباء

경고!

현 지역 및 국가의 전기 규정에 따라 장비를 설치해야 합니다.

Waarschuwing

Bij installatie van de apparatuur moet worden voldaan aan de lokale en nationale elektriciteitsvoorschriften.

## Product Disposal



**Warning!** Ultimate disposal of this product should be handled according to all national laws and regulations.

製品の廃棄

この製品を廃棄処分する場合、国の関係する全ての法律・条例に従い処理する必要があります。

警告

本产品的废弃处理应根据所有国家的法律和规章进行。

警告

本產品的廢棄處理應根據所有國家的法律和規章進行。

Warnung

Die Entsorgung dieses Produkts sollte gemäß allen Bestimmungen und Gesetzen des Landes erfolgen.

¡Advertencia!

Al deshacerse por completo de este producto debe seguir todas las leyes y reglamentos nacionales.

## Attention

La mise au rebut ou le recyclage de ce produit sont généralement soumis à des lois et/ou directives de respect de l'environnement. Renseignez-vous auprès de l'organisme compétent.

סילוק המוצר

אזהרה!

סילוק סופי של מוצר זה חייב להיות בהתאם להנחיות וחוקי המדינה.

التخلص النهائي من هذا المنتج ينبغي التعامل معه وفقا لجميع القوانين واللوائح الوطنية عند

## 경고!

이 제품은 해당 국가의 관련 법규 및 규정에 따라 폐기되어야 합니다.

## Waarschuwing

De uiteindelijke verwijdering van dit product dient te geschieden in overeenstemming met alle nationale wetten en reglementen.

## Hot Swap Fan Warning



**Warning!** Hazardous moving parts. Keep away from moving fan blades. The fans might still be turning when you remove the fan assembly from the chassis. Keep fingers, screwdrivers, and other objects away from the openings in the fan assembly's housing.

## ファン・ホットスワップの警告

警告!回転部品に注意。運転中は回転部(羽根)に触れないでください。シャーシから冷却ファン装置を取り外した際、ファンがまだ回転している可能性があります。ファンの開口部に、指、ドライバー、およびその他のものを近づけないで下さい。

## 警告!

警告! 危險的可移動性零件。請務必與轉動的风扇叶片保持距離。當您從機架移除風扇裝置，風扇可能仍在轉動。小心不要將手指、螺絲起子和其他物品太靠近風扇

## 警告

危險的可移動性零件。請務必與轉動的风扇叶片保持距離。當您從機架移除風扇裝置，風扇可能仍在轉動。小心不要將手指、螺絲起子和其他物品太靠近風扇。

**Warnung**

Gefährlich Bewegende Teile. Von den bewegenden Lüfterblätter fern halten. Die Lüfter drehen sich u. U. noch, wenn die Lüfterbaugruppe aus dem Chassis genommen wird. Halten Sie Finger, Schraubendreher und andere Gegenstände von den Öffnungen des Lüftergehäuses entfernt.

**¡Advertencia!**

Riesgo de piezas móviles. Mantener alejado de las aspas del ventilador. Los ventiladores podran dar vuelta cuando usted quite el montaje del ventilador del chasis. Mantenga los dedos, los destornilladores y todos los objetos lejos de las aberturas del ventilador

**Attention**

Pieces mobiles dangereuses. Se tenir a l'écart des lames du ventilateur Il est possible que les ventilateurs soient toujours en rotation lorsque vous retirerez le bloc ventilateur du châssis. Prenez garde à ce que doigts, tournevis et autres objets soient éloignés du logement du bloc ventilateur.

**אזהרה!**

חלקים נעים מסוכנים. התרחק מלהבי המאוורר בפעולה כאשר מסירים את חלקי המאוורר מהמארז, יתכן והמאווררים עדיין עובדים. יש להרחיק למרחק בטוח את האצבעות וכלי עבודה שונים מהפתחים בתוך המאוורר

تحذير! أجزاء متحركة خطيرة. ابتعد عن شفرات المروحة المتحركة. من الممكن أن المراوح لا تزال تدور عند إزالة كتلة المروحة من الهيكل يجب إبقاء الأصابع ومفكات البراغي وغيرها من الأشياء بعيدا عن الفتحات في كتلة المروحة

**경고!**

움직이는 위험한 부품. 회전하는 송풍 날개에 접근하지 마세요. 새시로부터 팬 조립품을 제거할 때 팬은 여전히 회전하고 있을 수 있습니다. 팬 조립품 외관의 열려있는 부분들로부터 손가락 및 스크류드라이버, 다른 물체들이 가까이 하지 않도록 배치해 주십시오.

**Waarschuwing**

Gevaarlijk bewegende onderdelen. Houd voldoende afstand tot de bewegende ventilatorbladen. Het is mogelijk dat de ventilator nog draait tijdens het verwijderen van het ventilatorsamenstel uit het chassis. Houd uw vingers, schroevendraaiers en eventuele andere voorwerpen uit de buurt van de openingen in de ventilatorbehuizing.

## Power Cable and AC Adapter



**Warning!** When installing the product, use the provided or designated connection cables, power cables and AC adapters. Using any other cables and adapters could cause a malfunction or a fire. Electrical Appliance and Material Safety Law prohibits the use of UL or CSA -certified cables (that have UL/CSA shown on the cord) for any other electrical devices than products designated by Supermicro only.

### 電源コードとACアダプター

製品を設置する場合、提供または指定および購入された接続ケーブル、電源コードとACアダプターを該当する地域の条例や安全基準に適合するコードサイズやプラグと共に使用下さい。他のケーブルやアダプタを使用すると故障や火災の原因になることがあります。

電気用品安全法は、ULまたはCSA認定のケーブル(UL/CSAマークがコードに表記)を Supermicro が指定する製品以外に使用することを禁止しています。

### 警告

安装此产品时,请使用本身提供的或指定的或采购的连接线,电源线和电源适配器。包含遵照当地法规和安全要求的合规的电源线尺寸和插头。使用其它线材或适配器可能会引起故障或火灾。除了Supermicro所指定的产品,电气用品和材料安全法律规定禁止使用未经UL或CSA认证的线材。(线材上会显示UL/CSA符号)。

### 警告

安裝此產品時,請使用本身提供的或指定的或採購的連接線,電源線和電源適配器。包含遵照當地法規和安全要求的合規的電源線尺寸和插頭。使用其它線材或適配器可能會引起故障或火災。除了Supermicro所指定的產品,電氣用品和材料安全法律規定禁止使用未經UL或CSA認證的線材。(線材上會顯示UL/CSA符號)。

### Warnung

Nutzen Sie beim Installieren des Produkts ausschließlich die von uns zur Verfügung gestellten Verbindungskabeln, Stromkabeln und/oder Adapter, die Ihre örtlichen Sicherheitsstandards einhalten. Der Gebrauch von anderen Kabeln und Adapter können Fehlfunktionen oder Feuer verursachen. Die Richtlinien untersagen das Nutzen von UL oder CAS zertifizierten Kabeln (mit UL/CSA gekennzeichnet), an Geräten oder Produkten die nicht mit Supermicro gekennzeichnet sind.

## ¡Advertencia!

Cuando instale el producto, utilice la conexión provista o designada o procure cables, Cables de alimentación y adaptadores de CA que cumplan con los códigos locales y los requisitos de seguridad, incluyendo el tamaño adecuado del cable y el enchufe. El uso de otros cables y adaptadores podría causar un mal funcionamiento o un incendio. La Ley de Seguridad de Aparatos Eléctricos y de Materiales prohíbe El uso de cables certificados por UL o CSA (que tienen el certificado UL / CSA en el código) para cualquier otros dispositivos eléctricos que los productos designados únicamente por Supermicro.

## Attention

Lors de l'installation du produit, utilisez les cables de connection fournis ou désigné ou achetez des cables, cables de puissance et adaptateurs respectant les normes locales et les conditions de securite y compris les tailles de cables et les prises electriques appropries. L'utilisation d'autres cables et adaptateurs peut provoquer un dysfonctionnement ou un incendie. Appareils électroménagers et la Loi sur la Sécurité Matériel interdit l'utilisation de câbles certifiés- UL ou CSA (qui ont UL ou CSA indiqué sur le code) pour tous les autres appareils électriques sauf les produits désignés par Supermicro seulement.

AC ימאתמו מיי למשח מילבכ

!הרהזא

ךרוצל ומאתוה וא ושכרנ רשא AC מיימאתמו מיקפס, מילבכב שמתשהל שי, רצומה תא מיניקתמ רשאכ לכב שומיש . עקתהו לבכה לש הנוכח הדימ ללוכ, תוימוקמה תוחיטבה תושירדל ומאתוה רשאו, הנקתהה למשחה ירישכמב שומישה יקוחל מאתהב. ילמשח רצק וא הלקתל מורגל לולע, רחא גוסמ מאתמ וא לבכ לש דוק מהילע עיפומ רשאכ) UL-ב או CSA-ב (ב-מייכמוסומה מילבכב שמתשהל רוסיא מייק, תוחיטבה יקוחו דבלב Supermicro י"ע מאתוה רשא רצומב קר אלא, רחא ילמשח רצומ לכ רובע UL/CSA)

תאלבאלא אארשב מץ וא אדדחמלא וא ארפוטמלא תאליטוטלא מאדחטסאב מץ, אגתנמלא בייקרת דנע לכלז יפ אמב אילחמלא אמאלסלא תאבלטתמו נינאווקב מאזתלאלא אמ דדרתמלא ראיטלא תאלוחמו אילברמלא קיירח וא לטע יפ בבסטטי דץ ירשא תאלוחמו תאלבאלא יא מאדחטסא. מילסלא סבאלאו ולסומלא מץ ח CSA וא UL לבק נמ אדמתמלא תאלבאלא מאדחטסא תאדמלאו אילברמלא אזהאלל אמאלסלא נונאק רזחי Supermicro לבק נמ אדדחמלאו אילברמלא תאגתנמלא רייג ירשא תאדמ יא אמ (UL/CSA) אמאלע למחתיטלאו

### 전원 케이블 및 AC 어댑터

경고! 제품을 설치할 때 현지 코드 및 적절한 굵기의 코드와 플러그를 포함한 안전 요구 사항을 준수하여 제공되거나 지정된 연결 혹은 구매 케이블, 전원 케이블 및 AC 어댑터를 사용하십시오.

다른 케이블이나 어댑터를 사용하면 오작동이나 화재가 발생할 수 있습니다. 전기 용품 안전법은 UL 또는 CSA 인증 케이블 (코드에 UL / CSA가 표시된 케이블)을 Supermicro 가 지정한 제품 이외의 전기 장치에 사용하는 것을 금지합니다.

### Stroomkabel en AC-Adapter

Waarschuwing! Bij het aansluiten van het Product uitsluitend gebruik maken van de geleverde Kabels of een andere geschikte aan te schaffen Aansluitmethode, deze moet altijd voldoen aan de lokale voorschriften en veiligheidsnormen, inclusief de juiste kabeldikte en stekker. Het gebruik van niet geschikte Kabels en/of Adapters kan een storing of brand veroorzaken. Wetgeving voor Elektrische apparatuur en Materiaalveiligheid verbied het gebruik van UL of CSA -gecertificeerde Kabels (met UL/CSA in de code) voor elke andere toepassing dan de door Supermicro hiervoor beoogde Producten.

# Appendix B

## System Specifications

### Processors

SYS-E302-12A-4C: Single Intel Atom® Processor C5315 in an FCBGA2106 socket

SYS-E302-12A-8C: Single Intel Atom® Processor C5325 in an FCBGA2106 socket

Note: Refer to the motherboard specifications pages on our website for updates to supported processors.

### Chipset

Intel® SoC

### BIOS

256Mb AMI SPI BIOS

### Memory

Up to 128GB of DDR4 ECC RDIMM memory to 2400 MT/s (4C) and 2933 MT/S (8C)

### Storage Drives

Supports one 2.5" drive of 7mm height or one 2.5" drive of 15mm height

### PCI Expansion Slots

One PCIe 3.0 x2 (in x8 slot)

One OCuLink supports PCIe x4/SATA/NVMe

### Input/Output

One RJ45 Dedicated IPMI LAN port

Four RJ45 Gigabit Ethernet LAN ports

Two SFP+ 10GbE LAN ports

Two USB 3.0 port(s) (2 USB)

One VGA port

### Motherboard

A3SPI-4C-LN6PF/8C-LN6PF; Mini-ITX, Dimensions: 6.7" (L) x 7.1" (W) (170.18 x 180.34mm)

### Chassis

CSE-302iL; SuperServer Rackmount, 11.6" x 2.9" x 8.1" (295 x 73 x 205mm) (WxHxD)

### Weight

Net Weight: 8lbs (3.63kg)

Gross Weight: 12lbs (5.44kg)

### System Cooling

Fanless

### Power Supply

150W 12V Lockable DC Power Adapter (Optional: 180W 12V Lockable DC Power Adapter)

### Operating Environment

Operating Temperature: 0° to 45° C (32° to 113° F)

Non-operating Temperature: -40° to 70° C (-40° to 158° F)

Operating Relative Humidity: 8% to 90% (non-condensing)

Non-operating Relative Humidity: 5% to 95% (non-condensing)

**Regulatory Compliance**

FCC, ICES, CE, VCCI, RCM, UKCA, NRTL, CB

**Applied Directives, Standards**

EMC/EMI: 2014/30/EU (EMC Directive)

FCC Part 15 Subpart B

ICES-003

VCCI-CISPR 32

AS/NZS CISPR 32

EN/BS EN55032

EN/BS EN55035

CISPR 32

CISPR 35

EN/BS 61000-3-2

EN/BS 61000-3-3

EN/BS 61000-4-2

EN/BS 61000-4-3

EN/BS 61000-4-4

EN/BS 61000-4-5

EN/BS 61000-4-6

EN/BS 61000-4-8

EN/BS 61000-4-11

Green Environment:

2011/65/EU (RoHS Directive)

EC 1907/2006 (REACH)

2012/19/EU (WEEE Directive)

California Proposition 65

Product Safety: 2014/35/EU (LVD Directive)

UL/CSA 62368-1 (USA and Canada)

IEC/EN 62368-1

IEC 60950-1 2nd Edition

**Perchlorate Warning**

California Best Management Practices Regulations for Perchlorate Materials: This Perchlorate warning applies only to products containing CR (Manganese Dioxide) Lithium coin cells. "Perchlorate Material-special handling may apply. See [www.dtsc.ca.gov/hazardouswaste/perchlorate](http://www.dtsc.ca.gov/hazardouswaste/perchlorate)"

この装置は、クラスA機器です。この装置を住宅環境で使用すると電波妨害を引き起こすことがあります。この場合には使用者が適切な対策を講ずるよう要求されることがあります。

VCCI — A