

SUPERO®

SuperWorkstation 5046A-X

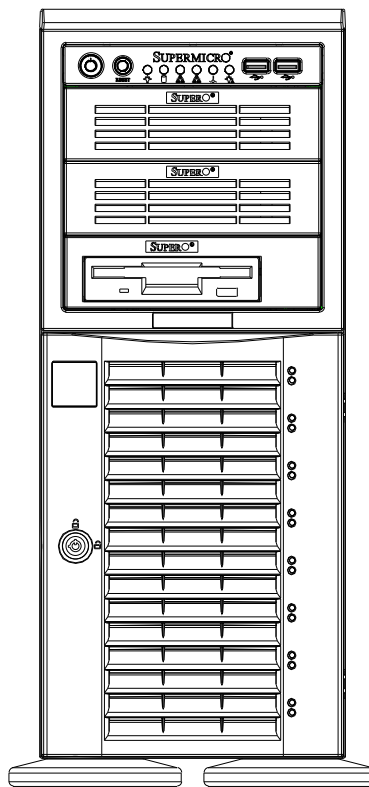

USER'S MANUAL

1.0a

The information in this User's Manual has been carefully reviewed and is believed to be accurate. The vendor assumes no responsibility for any inaccuracies that may be contained in this document, makes no commitment to update or to keep current the information in this manual, or to notify any person or organization of the updates. **Please Note: For the most up-to-date version of this manual, please see our web site at www.supermicro.com.**

Super Micro Computer, Inc. ("Supermicro") reserves the right to make changes to the product described in this manual at any time and without notice. This product, including software, if any, and documentation may not, in whole or in part, be copied, photocopied, reproduced, translated or reduced to any medium or machine without prior written consent.

IN NO EVENT WILL SUPERMICRO BE LIABLE FOR DIRECT, INDIRECT, SPECIAL, INCIDENTAL, SPECULATIVE OR CONSEQUENTIAL DAMAGES ARISING FROM THE USE OR INABILITY TO USE THIS PRODUCT OR DOCUMENTATION, EVEN IF ADVISED OF THE POSSIBILITY OF SUCH DAMAGES. IN PARTICULAR, SUPERMICRO SHALL NOT HAVE LIABILITY FOR ANY HARDWARE, SOFTWARE, OR DATA STORED OR USED WITH THE PRODUCT, INCLUDING THE COSTS OF REPAIRING, REPLACING, INTEGRATING, INSTALLING OR RECOVERING SUCH HARDWARE, SOFTWARE, OR DATA.

Any disputes arising between manufacturer and customer shall be governed by the laws of Santa Clara County in the State of California, USA. The State of California, County of Santa Clara shall be the exclusive venue for the resolution of any such disputes. Super Micro's total liability for all claims will not exceed the price paid for the hardware product.

This equipment has been tested and found to comply with the limits for a Class B digital device pursuant to Part 15 of the FCC Rules. These limits are designed to provide reasonable protection against harmful interference in a residential installation. This equipment generates, uses, and can radiate radio frequency energy and, if not installed and used in accordance with the manufacturer's instruction manual, may cause interference with radio communications. However, there is no guarantee that interference will not occur in a particular installation. If this equipment does cause harmful interference to radio or television reception, which can be determined by turning the equipment off and on, you are encouraged to try to correct the interference by one or more of the following measures: Reorient or relocate the receiving antenna. Increase the separation between the equipment and the receiver. Connect the equipment into an outlet on a circuit different from that to which the receiver is connected. Consult the dealer or an experienced radio/television technician for help.

California Best Management Practices Regulations for Perchlorate Materials: This Perchlorate warning applies only to products containing CR (Manganese Dioxide) Lithium coin cells. "Perchlorate Material-special handling may apply. See www.dtsc.ca.gov/hazardouswaste/perchlorate"

WARNING: Handling of lead solder materials used in this product may expose you to lead, a chemical known to the State of California to cause birth defects and other reproductive harm.

Manual Revision 1.0a
Release Date: March 2, 2010

Unless you request and receive written permission from Super Micro Computer, Inc., you may not copy any part of this document.

Information in this document is subject to change without notice. Other products and companies referred to herein are trademarks or registered trademarks of their respective companies or mark holders.

Copyright © 2010 by Super Micro Computer, Inc.
All rights reserved.

Printed in the United States of America

Preface

About This Manual

This manual is written for professional system integrators and PC technicians. It provides information for the installation and use of the SuperWorkstation 5046A-X. Installation and maintenance should be performed by experienced technicians only.

The SuperWorkstation 5046A-X is a high-end system based on the SC743TS-865-BP-SQ tower/4U rackmount chassis and the C7X58 serverboard.

Manual Organization

Chapter 1: Introduction

The first chapter provides a checklist of the main components included with the system and describes the main features of the C7X58 serverboard and the SC743TS-865BP-SQ chassis, which comprise the SuperWorkstation 5046A-X.

Chapter 2: Server Installation

This chapter describes the steps necessary to setup the SuperWorkstation 5046A-X into a rack and check out the server configuration prior to powering up the system. If your system was ordered without processor and memory components, this chapter will refer you to the appropriate sections of the manual for their installation.

Chapter 3: System Interface

Refer here for details on the system interface, which includes the functions and information provided by the control panel on the chassis as well as other LEDs located throughout the system.

Chapter 4: System Safety

You should thoroughly familiarize yourself with this chapter for a general overview of safety precautions that should be followed when installing and servicing the SuperWorkstation 5046A-X.

Chapter 5: Advanced Serverboard Setup

Chapter 5 provides detailed information on the C7X58 serverboard, including the locations and functions of connections, headers and jumpers. Refer to this chapter when adding or removing processors or main memory and when reconfiguring the serverboard.

Chapter 6: Advanced Chassis Setup

Refer to Chapter 6 for detailed information on the SC743TS-865BP-SQ chassis. You should follow the procedures given in this chapter when installing, removing or reconfiguring SAS/SATA or peripheral drives and when replacing system power supply units and cooling fans.

Chapter 7: BIOS

The BIOS chapter includes an introduction to BIOS and provides detailed information on running the CMOS Setup Utility.

Appendix A: POST Error Beep Codes

Appendix B: Software Installation Instructions

Appendix C: System Specifications

Notes

Table of Contents

Chapter 1 Introduction

1-1	Overview	1-1
1-2	Serverboard Features	1-2
	Processors	1-2
	Memory	1-2
	Serial ATA	1-2
	PCI Expansion Slots	1-2
	Onboard Controllers/Ports	1-2
	Other Features	1-3
1-3	Server Chassis Features	1-3
	System Power	1-3
	SAS Subsystem	1-3
	SATA Subsystem.....	1-3
	Front Control Panel.....	1-3
	I/O Backplane.....	1-3
	Cooling System	1-4
1-4	Contacting Supermicro.....	1-6

Chapter 2 Server Installation

2-1	Overview	2-1
2-2	Unpacking the System	2-1
2-3	Preparing for Setup.....	2-1
	Choosing a Setup Location.....	2-2
	Rack Precautions	2-2
	Server Precautions.....	2-2
	Rack Mounting Considerations	2-3
	Ambient Operating Temperature	2-3
	Reduced Airflow	2-3
	Mechanical Loading	2-3
	Circuit Overloading.....	2-3
	Reliable Ground	2-3
2-4	Installing the System into a Rack	2-4
	Identifying the Sections of the Rack Rails	2-4
	Installing the Chassis Rails.....	2-5
	Installing the Rack Rails	2-6

	Installing the Server into the Rack.....	2-7
2-5	Checking the Serverboard Setup.....	2-8
2-6	Checking the Drive Bay Setup.....	2-9
Chapter 3 System Interface		
3-1	Overview	3-1
3-2	Control Panel Buttons	3-1
	Power	3-1
	Reset.....	3-1
3-3	Control Panel LEDs	3-2
	Power	3-2
	HDD.....	3-2
	NIC1	3-2
	NIC2	3-2
	Overheat/Fan Fail	3-2
	Power Fail	3-3
3-4	Drive Carrier LEDs.....	3-3
	SAS Drives.....	3-3
	SATA Drives	3-3
Chapter 4 System Safety		
4-1	Electrical Safety Precautions	4-1
4-2	General Safety Precautions	4-2
4-3	ESD Precautions.....	4-3
4-4	Operating Precautions	4-4
Chapter 5 Advanced Serverboard Setup		
5-1	Handling the Serverboard	5-1
	Precautions	5-1
	Unpacking	5-2
5-2	Serverboard Installation	5-2
5-3	Connecting Cables.....	5-3
	Connecting Data Cables	5-3
	Connecting Power Cables	5-3
	Connecting the Control Panel.....	5-3
5-4	I/O Ports	5-4
5-5	Processor and Heatsink Installation.....	5-5
	Installing an LGA 1366 Processor.....	5-5
5-6	Installing Memory Modules	5-8
	Installing & Removing DIMMs.....	5-8
5-7	Adding PCI Add-On Cards.....	5-10

5-8	Serverboard Details	5-11
	C7X58 Quick Reference	5-12
5-9	Connector Definitions	5-13
5-10	Jumper Settings	5-20
5-11	Onboard Indicators.....	5-23
5-12	Floppy and SATA Ports.....	5-24

Chapter 6 Advanced Chassis Setup

6-1	Static-Sensitive Devices.....	6-1
	Precautions	6-1
	Unpacking	6-1
6-2	Front Control Panel.....	6-3
6-3	System Fans	6-4
	Fan Failure.....	6-4
	Replacing Chassis Cooling Fans.....	6-4
6-4	Drive Bay Installation	6-6
	SAS/SATA Backplane.....	6-7
	Installing Components in the 5.25" Drive Bays	6-8
6-5	Power Supply	6-9
	Power Supply Failure.....	6-9

Chapter 7 BIOS

7-1	Introduction.....	7-1
	Starting BIOS Setup Utility.....	7-1
	How To Change the Configuration Data.....	7-1
	Starting the Setup Utility	7-2
7-2	Main Setup	7-2
7-3	Advanced Setup Configurations.....	7-4
7-4	Security Settings	7-20
7-5	Boot Configuration	7-21
7-6	Exit Options.....	7-22

Appendix A POST Error Beep Codes

Appendix B Software Installation Instructions

Appendix C System Specifications

Chapter 1

Introduction

1-1 Overview

The 5046A-X is a high-end workstation comprised of two main subsystems: the SC743TS-865BP-SQ tower/4U chassis and the C7X58 single Intel Xeon processor serverboard. Please refer to our web site for information on operating systems that have been certified for use with the SuperWorkstation 5046A-X (www.supermicro.com).

In addition to the serverboard and chassis, various hardware components have been included with the SuperWorkstation 5046A-X, as listed below:

- Two (2) 8-cm hot-swap PWM "SuperQuiet" chassis fans (FAN-0104L4)
- One (1) 9-cm PWM "SuperQuiet" exhaust fan (FAN-0103L4)
- One (1) CPU heatsink (SNK-P0035AP4)
- One (1) cable for DVD drive (CBL-0140L) (optional)
- One (1) floppy cable (CBL-112L)
- SATA Accessories
 - One (1) SATA backplane (CSE-SAS-743TQ)
 - Six (6) SATA cables (CBL-0061L)
 - Two (2) SGPIO cables (CBL-0157L)
 - One (1) internal to external IEEE1394 "FireWire" cable (CBL-0173L)
 - Six (6) SATA hot-swap drive carriers [CSE-PT17(B)]
- Optional:
 - Two (2) 8-cm PWM fans (FAN-0104L4)
 - One (1) rackmount kit [CSE-PT26L-(B)]
 - One (1) 3.5" floppy drive (FPD-TEAC-FB)
 - One (1) DVD drive (DVM-SONY-DVDRW24-HBT)

1-2 Serverboard Features

At the heart of the SuperWorkstation 5046A-X lies the C7X58, a single processor serverboard based on the Intel X58 + ICH10R chipset. Below are the main features of the C7X58. (See Figure 1-1 for a block diagram of the chipset).

Processors

The C7X58 supports a single Intel Core™ i7, i7 Extreme Edition or future Intel Nehalem processor families (next generation Intel Xeon® processor). Please refer to the serverboard description pages on our web site for a complete listing of supported processors (www.supermicro.com).

Memory

The C7X58 has six DIMM slots that can support up to 24 GB of unbuffered ECC or non-ECC DDR3-1600/1333/1066/800 SDRAM. Single channel and dual-channel interleaved configurations are supported. Modules of the same size and speed should be used. See Chapter 5 for details.

Serial ATA

A SATA controller is integrated into the South Bridge (ICH10R) section of the chipset to provide a six-port Serial ATA subsystem, which is RAID 0, 1, 10 and 5 capable. The Serial ATA drives are hot-swappable units.

Note: The operating system you use must have RAID support to enable the hot-swap capability and RAID function of the Serial ATA drives.

PCI Expansion Slots

The C7X58 has two PCI-E 2.0 x16, one PCI-E x4 (in a x8 slot) and one 32-bit PCI slots.

Onboard Controllers/Ports

One floppy drive controller and two onboard ATA/100 controllers are provided to support up to two IDE hard drives or ATAPI devices (one IDE connection is reserved for a Compact Flash card). The color-coded I/O ports include two COM ports, six USB 2.0 ports, PS/2 mouse and keyboard ports, one Gb Ethernet port and six HDA (High Definition Audio) ports. Two IEEE 1394a "Firewire" headers are also included onboard.

Other Features

Other onboard features that promote system health include onboard voltage monitors, a chassis intrusion header, auto-switching voltage regulators, chassis and CPU overheat sensors, virus protection and BIOS rescue.

1-3 Chassis Features

The SuperWorkstation 5046A-X is a scaleable system designed with today's most state-of-the-art features. The following is a general outline of the main features of the SC743TS-865BP-SQ chassis.

System Power

The 5046A-X features a single 865W power supply. This power supply unit has been designed to operate at a low noise level to make it ideal for use in a workstation environment.

SAS Subsystem

The SC743TS-865BP-SQ chassis was designed to support eight SAS hard drives, which are hot-swappable units (7045A-C3 only).

SATA Subsystem

The SC743TS-865BP-SQ supports up to six 3 Gb/s Serial ATA drives. The SATA drives are hot-swappable units and are connected to a backplane that provides power and control.

Front Control Panel

The control panel on the SuperWorkstation 5046A-X provides you with system monitoring and control. LEDs indicate system power, HDD activity, network activity, overheat conditions and power supply failure. A main power button and a system reset button are also included.

Note: the power supply fail LED indicates the power supply fan has failed.

I/O Backplane

The SC743TS-865BP-SQ is an ATX form factor chassis that can be used as a tower or mounted in a 4U rackmount configuration. The I/O backplane provides seven expansion slots, two COM ports, a parallel port, four USB 2.0 ports, PS/2 mouse and keyboard ports, two Gigabit Ethernet port(s) and 7.1 HDA ports.

Cooling System

The SC743TS-865BP-SQ chassis has an innovative "Super Quiet" cooling design that provides sufficient cooling at very low noise level - ideal for a workplace environment. The chassis includes two 8-cm hot-plug PWM (Pulse Width Modulation) system cooling fans located in the middle of the chassis. The system cooling fans work with an air shroud to cool the areas where the most heat is generated. A 9-cm PWM exhaust fan is also located at the rear of the chassis.

The power supply has two fans for redundancy; if one fan fails the other will increase its rpm to compensate. This may cause the system to run louder than usual. See details in Chapter 6.

**Figure 1-1. Intel X58 Chipset:
System Block Diagram**

Note: This is a general block diagram. Please see Chapter 5 for details.

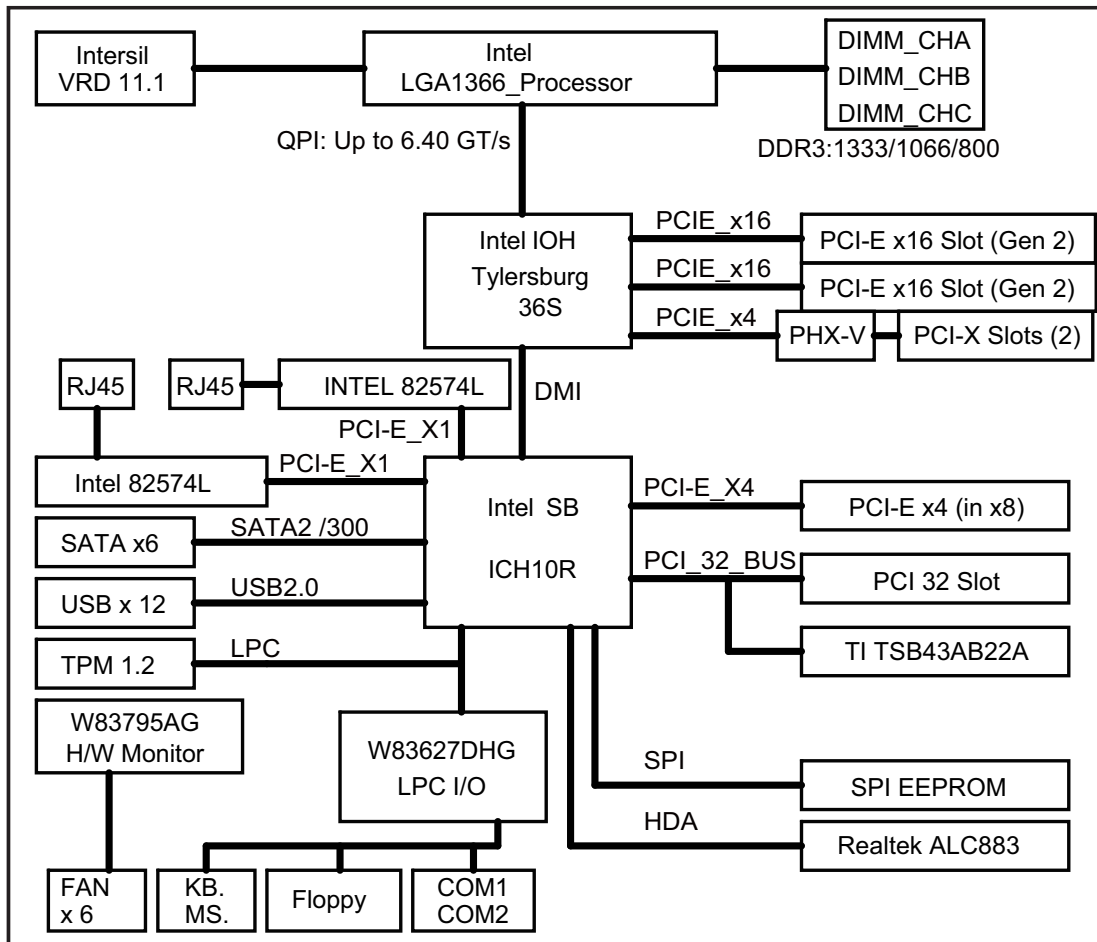

1-4 Contacting Supermicro

Headquarters

Address: Super Micro Computer, Inc.
980 Rock Ave.
San Jose, CA 95131 U.S.A.

Tel: +1 (408) 503-8000

Fax: +1 (408) 503-8008

Email: marketing@supermicro.com (General Information)
support@supermicro.com (Technical Support)

Web Site: www.supermicro.com

Europe

Address: Super Micro Computer B.V.
Het Sterrenbeeld 28, 5215 ML
's-Hertogenbosch, The Netherlands

Tel: +31 (0) 73-6400390

Fax: +31 (0) 73-6416525

Email: sales@supermicro.nl (General Information)
support@supermicro.nl (Technical Support)
rma@supermicro.nl (Customer Support)

Asia-Pacific

Address: Super Micro Computer, Inc.
4F, No. 232-1, Liancheng Rd.
Chung-Ho 235, Taipei County
Taiwan, R.O.C.

Tel: +886-(2) 8226-3990

Fax: +886-(2) 8226-3991

Web Site: www.supermicro.com.tw

Technical Support:

Email: support@supermicro.com.tw

Tel: 886-2-8228-1366, ext.132 or 139

Chapter 2

Installation

2-1 Overview

This chapter provides a quick setup checklist to get your SuperWorkstation 5046A-X up and running. Following these steps in the order given should enable you to have the system operational within a minimum amount of time. This quick setup assumes that your system has come to you with the processor and memory preinstalled. If your system is not already fully integrated with a serverboard, processor, system memory etc., please turn to the chapter or section noted in each step for details on installing specific components.

The 5046A-X may be employed either as a tower or mounted in a rack as a 4U rackmount chassis. If using it as a tower unit, please read the Server Precautions in the next section and then skip ahead to Section 2-5.

2-2 Unpacking the System

You should inspect the box the system was shipped in and note if it was damaged in any way. If the system itself shows damage you should file a damage claim with the carrier who delivered it.

Decide on a suitable location for the SuperWorkstation 5046A-X. It should be situated in a clean, dust-free area that is well ventilated. Avoid areas where heat, electrical noise and electromagnetic fields are generated. You will also need it placed near a grounded power outlet. Be sure to read the Rack and Server Precautions in the next section.

2-3 Preparing for Setup

The box the system was shipped in may include two sets of rail assemblies, two rail mounting brackets and mounting screws needed for installing the system into a rack (optional kit). Follow the steps in the order given to complete the installation process in a minimum amount of time. Please read this section in its entirety before you begin the installation procedure outlined in the sections that follow.

Choosing a Setup Location

- Leave enough clearance in front of the rack to enable you to open the front door completely (~25 inches) and approximately 30 inches of clearance in the back of the rack to allow for sufficient airflow and ease in servicing.
- This product is not suitable for use with visual display work place devices according to §2 of the the German Ordinance for Work with Visual Display Units.



Warnings and Precautions!



Rack Precautions

- Ensure that the leveling jacks on the bottom of the rack are fully extended to the floor with the full weight of the rack resting on them.
- In single rack installation, stabilizers should be attached to the rack. In multiple rack installations, the racks should be coupled together.
- Always make sure the rack is stable before extending a component from the rack.
- You should extend only one component at a time - extending two or more simultaneously may cause the rack to become unstable.

Server Precautions

- Review the electrical and general safety precautions in Chapter 4.
- Determine the placement of each component in the rack *before* you install the rails.
- Install the heaviest server components on the bottom of the rack first, and then work up.
- Use a regulating uninterruptible power supply (UPS) to protect the server from power surges, voltage spikes and to keep your system operating in case of a power failure.

- Allow the hot plug SAS/SATA drives and power supply modules to cool before touching them.
- Always keep the rack's front door and all panels and components on the servers closed when not servicing to maintain proper cooling.

Rack Mounting Considerations

Ambient Operating Temperature

If installed in a closed or multi-unit rack assembly, the ambient operating temperature of the rack environment may be greater than the ambient temperature of the room. Therefore, consideration should be given to installing the equipment in an environment compatible with the manufacturer's maximum rated ambient temperature (T_{mra}).

Reduced Airflow

Equipment should be mounted into a rack so that the amount of airflow required for safe operation is not compromised.

Mechanical Loading

Equipment should be mounted into a rack so that a hazardous condition does not arise due to uneven mechanical loading.

Circuit Overloading

Consideration should be given to the connection of the equipment to the power supply circuitry and the effect that any possible overloading of circuits might have on overcurrent protection and power supply wiring. Appropriate consideration of equipment nameplate ratings should be used when addressing this concern.

Reliable Ground

A reliable ground must be maintained at all times. To ensure this, the rack itself should be grounded. Particular attention should be given to power supply connections other than the direct connections to the branch circuit (i.e. the use of power strips, etc.).

2-4 Installing the System into a Rack

This section provides information on installing the system into a rack unit. Rack installation requires the use of the optional rackmount kit. If the system has already been mounted into a rack or if you are using it as a tower, you can skip ahead to Sections 2-5 and 2-6.

There are a variety of rack units on the market, which may mean the assembly procedure will differ slightly. The following is a guideline for installing the system into a rack with the rack rails provided in the rackmount kit. You should also refer to the installation instructions that came with the rack unit you are using.

Identifying the Sections of the Rack Rails

The optional rackmount kit includes two rack rail assemblies. Each of these assemblies consist of three sections: an inner fixed chassis rail that secures to the chassis, an outer rack rail that secures directly to the rack itself and two rail brackets, which also attach to the rack (see Figure 2-1.) The inner and outer rails must be detached from each other to install.

To remove the inner chassis rail, pull it out as far as possible - you should hear a "click" sound as a locking tab emerges from inside the rail assembly and locks the inner rail. Depress the locking tab to pull the inner rail completely out. Do this for both assemblies (one for each side).

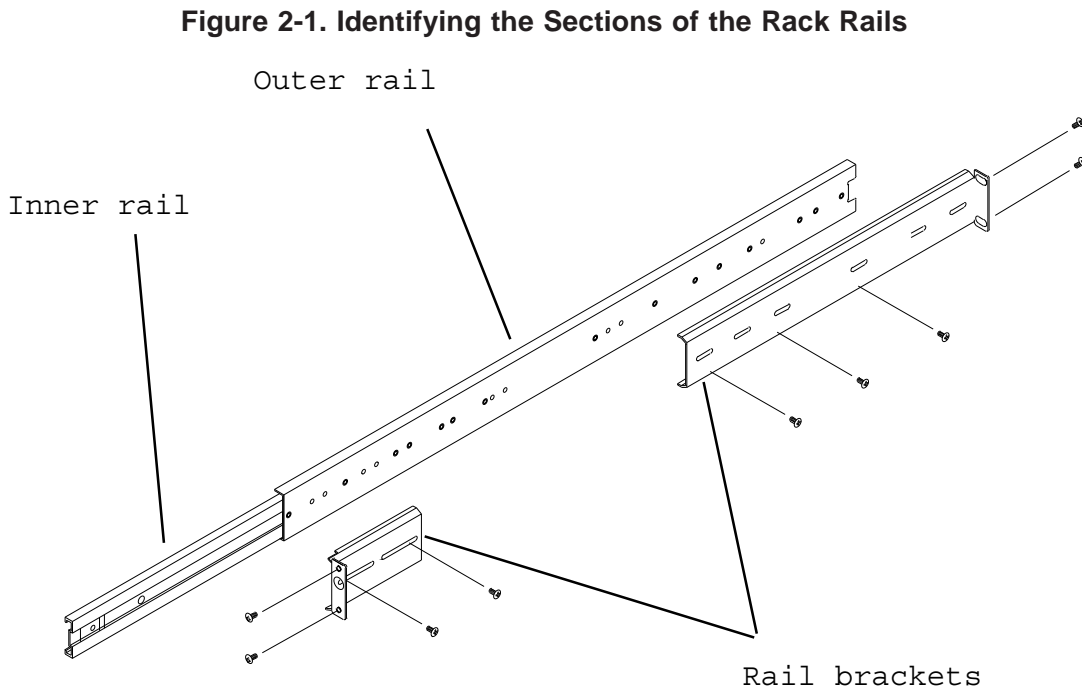

Installing the Chassis Rails

You will need to remove the top cover and the feet to add rack rails to the chassis. First, remove the top and right covers (top and left covers when standing as a tower chassis) by first removing the screws that secure them to the chassis. Depress the button on the top (side if tower) of the chassis to release the cover and then pull the cover off. Then unscrew the four feet and remove them from the chassis (see Figure 2-2).

You can now attach rack rails to the top and bottom (now the sides) of the chassis. First add the rack handles. Then position the inner chassis rail sections you just removed along the side of the chassis making sure the screw holes line up. Note that these two rails are left/right specific. Screw the rail securely to the side of the chassis (see Figure 2-3). Repeat this procedure for the other rail on the other side of the chassis. You will also need to attach the rail brackets when installing into a telco rack.

Locking Tabs: As mentioned, the chassis rails have a locking tab, which serves two functions. The first is to lock the system into place when installed and pushed fully into the rack, which is its normal position. Secondly, these tabs also lock the system in place when fully extended from the rack. This prevents the system from coming completely out of the rack when you pull it out for servicing.

Figure 2-2. Preparing to Install the Chassis Rails

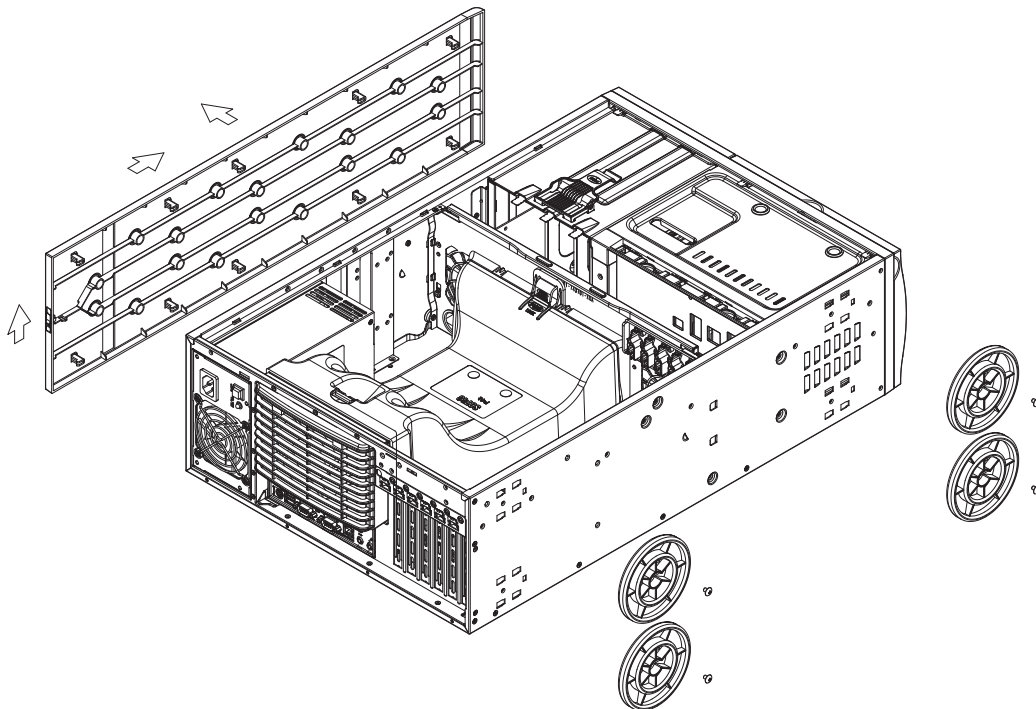
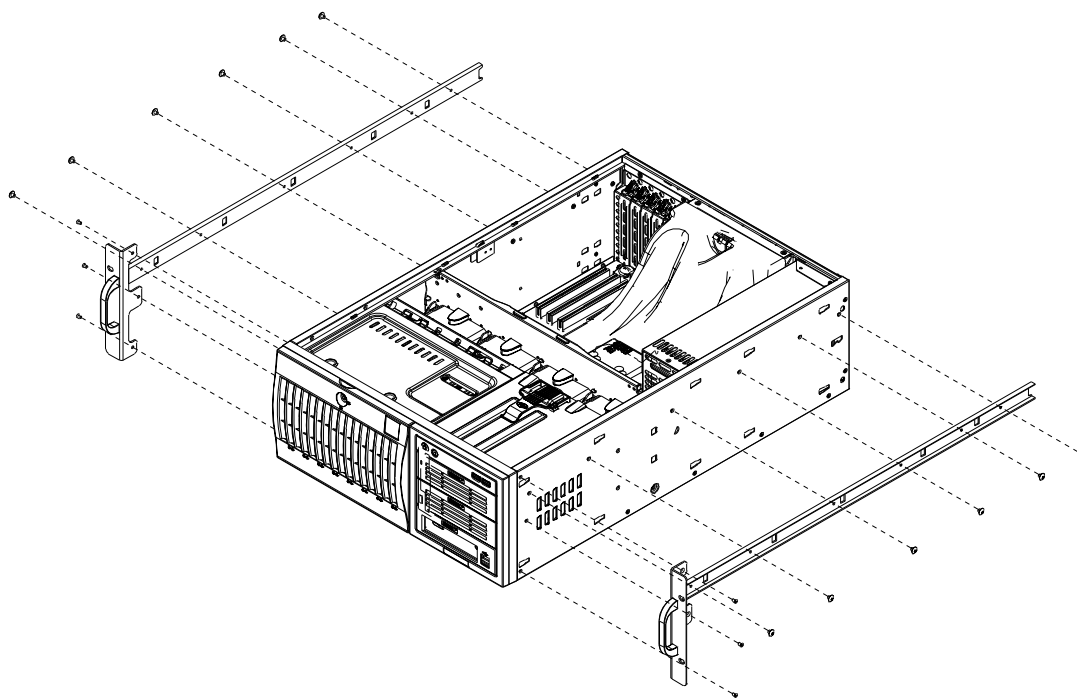

Figure 2-3. Installing the Rails to the Chassis



Installing the Rack Rails

Determine where you want to place the SuperWorkstation 5046A-X in the rack. ([See Rack and Server Precautions in Section 2-3.](#)) Position the fixed rack rail/sliding rail guide assemblies at the desired location in the rack, keeping the sliding rail guide facing the inside of the rack. Screw the assembly securely to the rack using the brackets provided. Attach the other assembly to the other side of the rack, making sure both are at the exact same height and with the rail guides facing inward.

Installing the System into the Rack

You should now have rails attached to both the chassis and the rack unit. The next step is to install the system into the rack. You should have two brackets in the rack mount kit. Install these first keeping in mind that they are left/right specific (marked with "L" and "R"). Then, line up the rear of the chassis rails with the front of the rack rails. Slide the chassis rails into the rack rails, keeping the pressure even on both sides (you may have to depress the locking tabs when inserting).

When the system has been pushed completely into the rack, you should hear the locking tabs "click". Finish by inserting and tightening the thumbscrews that hold the front of the chassis to the rack (see Figure 2-4).

Figure 2-4. Installing the System into a Rack

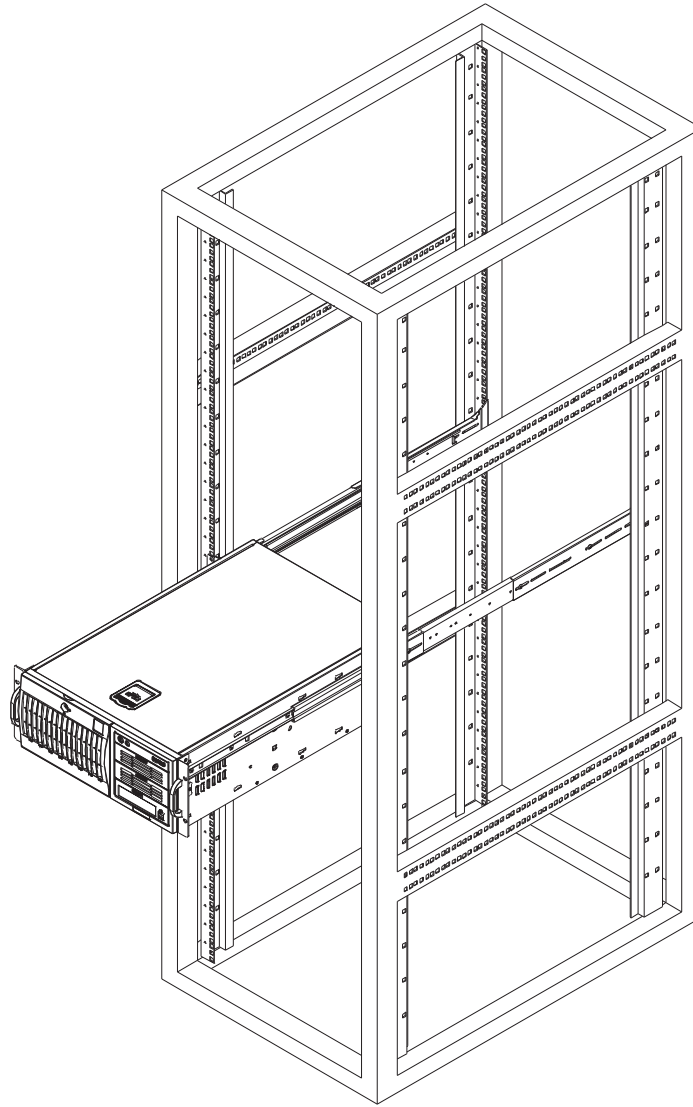

2-5 Checking the Serverboard Setup

After setting up the the system, you will need to open the unit to make sure the serverboard is properly installed and all the connections have been made.

Accessing the Inside of the System

1. If rack mounted, first release the retention screws that secure the unit to the rack. Then grasp the two handles on either side and pull the unit straight out until it locks (you will hear a "click").
2. There are two screws that secure the cover to the chassis - remove these first. Locate the latch on the top (side if tower) of the chassis - depress where it says "push" then lift the latch to release the cover. You can then lift the cover from the chassis to gain full access to the inside of the system. See Figure 2-5.

Checking the Components and Setup

1. You may have a processor already installed into the serverboard. The processor should have its own heatsink attached. See Chapter 5 for instructions on processor installation.
2. Your system may have come with system memory already installed. Make sure all DIMMs are fully seated in their slots. For details on adding system memory, refer to Chapter 5.
3. If desired, you can install add-on cards to the system. See Chapter 5 for details on installing PCI add-on cards.
4. Make sure all power and data cables are properly connected and not blocking the chassis airflow. See Chapter 5 for details on cable connections.

**Figure 2-5. Accessing the Inside of the System
(Rack Configuration shown)**

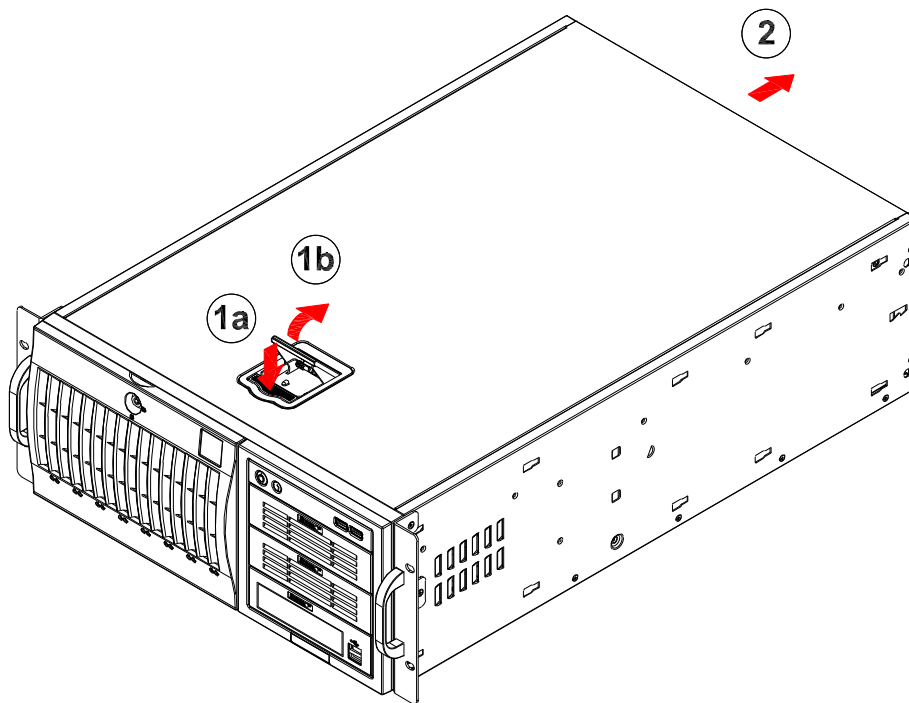

2-6 Checking the Drive Bay Setup

Next, you should check to make sure the peripheral drives and the SAS/SATA drives and backplane have been properly installed and all connections have been made.

Checking the Drives

1. All drives can be accessed from the front of the system. For servicing the CD-ROM, IDE hard drives and floppy drives, you will need to remove the top/left chassis cover. The SAS/SATA disk drives can be installed and removed from the front of the chassis without removing any chassis covers.
2. To install components into the 5.25" drive bays, you must first remove the top/left chassis cover as described in the previous section. Refer to Chapter 6 for details.
3. Refer to Chapter 6 if you need to reinstall a CD-ROM and/or floppy disk drive to the system.

4. Depending upon your system's configuration, your system may have one or more drives already installed. If you need to install SAS/SATA drives, please refer to Chapter 6.

Checking the Airflow

1. Airflow is provided by four hot-swap 8-cm chassis fans working in conjunction with an air shroud. One 9-cm exhaust fan is also mounted at the rear of the chassis. The system component layout was carefully designed to promote sufficient airflow through the chassis.
2. Note that all power and data cables have been routed in such a way that they do not block the airflow generated by the fans. Keep this in mind when you reroute them after working on the system.

Providing Power

1. Plug the power cords from the power supplies unit into a high-quality power strip that offers protection from electrical noise and power surges. It is recommended that you use an uninterruptible power supply (UPS).
2. Depress the power on button on the front of the chassis.

Chapter 3

System Interface

3-1 Overview

The control panel on the 5046A-X has several LEDs and two buttons. There are also two LEDs on each SAS/SATA drive carrier. These LEDs keep you constantly informed of the overall status of the system and the activity and health of specific components.

3-2 Control Panel Buttons

There are two push-buttons located on the front of the chassis: a power on/off button and a reset button.



Power

This is the main power button, which is used to apply or turn off the main system power. Turning off system power with this button removes the main power but keeps standby power supplied to the system.



Reset

Use the reset button to reboot the system.

3-3 Control Panel LEDs

The control panel located on the front of the SC743TS-865BP-SQ chassis has six LEDs that provide you with critical information related to different parts of the system. This section explains what each LED indicates when illuminated and any corrective action you may need to take.



Power

Indicates power is being supplied to the system's power supply. This LED should normally be on when the system is operating.

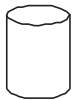

HDD

Indicates IDE channel activity. On the 5046A-X, this LED indicates SAS/SATA drive activity when flashing.



NIC1

Indicates network activity on LAN1 when flashing.

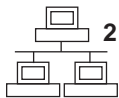

NIC2

Indicates network activity on LAN2 when flashing.

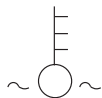

Overheat/Fan Fail

When this LED flashes, it indicates a chassis fan failure. When on continuously it indicates an overheat condition, which may be caused by cables obstructing the

airflow in the system or the ambient room temperature being too warm. Check the routing of the cables and make sure all fans are present and operating normally. You should also check to make sure that the chassis covers are installed. Finally, verify that the heatsinks are installed properly (see Chapter 5). This LED will remain flashing or on as long as the indicated condition exists.



Power Fail

Indicates a power supply fan has failed. The power supply module has a redundant backup fan that will increase its rpm to compensate, but the power module should be replaced as soon as it's convenient.

3-4 Drive Carrier LEDs

Note: the LEDs of some drive carriers may not function depending on the number of drives that are supported by the motherboard and/or backplane.

SAS Drives

- **Green:** When illuminated, the green LED on the front of the SAS drive carrier indicates drive activity. A connection to the SAS backplane enables this LED to blink on and off when that particular drive is being accessed.
- **Red:** The SES2 backplane activates the red LED to indicate a drive failure. If one of the SAS drives fail, you should be notified by your system management software. Please refer to Chapter 6 for instructions on replacing failed SAS drives.

SATA Drives

- **Green:** Each SATA drive carrier has a green LED. When illuminated, this green LED (on the front of the SATA drive carrier) indicates drive activity. A connection to the SATA backplane enables this LED to blink on and off when that particular drive is being accessed. Please refer to Chapter 6 for instructions on replacing failed SATA drives.
- **Red:** The red LED to indicate an SATA drive failure. If one of the SATA drives fail, you should be notified by your system management software. Please refer to Chapter 6 for instructions on replacing failed SATA drives.

Notes

Chapter 4

System Safety

4-1 Electrical Safety Precautions



Basic electrical safety precautions should be followed to protect yourself from harm and the SuperWorkstation 5046A-X from damage:

- Be aware of the locations of the power on/off switch on the chassis as well as the room's emergency power-off switch, disconnection switch or electrical outlet. If an electrical accident occurs, you can then quickly remove power from the system.
- Do not work alone when working with high voltage components.
- Power should always be disconnected from the system when removing or installing main system components, such as the serverboard, memory modules and the CD-ROM and floppy drives. When disconnecting power, you should first power down the system with the operating system and then unplug the power cords of all the power supply units in the system.
- When working around exposed electrical circuits, another person who is familiar with the power-off controls should be nearby to switch off the power if necessary.
- Use only one hand when working with powered-on electrical equipment. This is to avoid making a complete circuit, which will cause electrical shock. Use extreme caution when using metal tools, which can easily damage any electrical components or circuit boards they come into contact with.
- Do not use mats designed to decrease electrostatic discharge as protection from electrical shock. Instead, use rubber mats that have been specifically designed as electrical insulators.
- The power supply power cord must include a grounding plug and must be plugged into grounded electrical outlets.

- Serverboard Battery: **CAUTION** - There is a danger of explosion if the onboard battery is installed upside down, which will reverse its polarities (see Figure 4-1). This battery must be replaced only with the same or an equivalent type recommended by the manufacturer. Dispose of used batteries according to the manufacturer's instructions.
- DVD-ROM Laser: **CAUTION** - this server may have come equipped with a DVD-ROM drive. To prevent direct exposure to the laser beam and hazardous radiation exposure, do not open the enclosure or use the unit in any unconventional way.
- Mainboard replaceable soldered-in fuses: Self-resetting PTC (Positive Temperature Coefficient) fuses on the mainboard must be replaced by trained service technicians only. The new fuse must be the same or equivalent as the one replaced. Contact technical support for details and support.

4-2 General Safety Precautions



Follow these rules to ensure general safety:

- Keep the area around the SuperWorkstation 5046A-X clean and free of clutter.
- The 5046A-X weighs approximately 64 lbs (29.1 kg.) when fully loaded. When lifting the system, two people at either end should lift slowly with their feet spread out to distribute the weight. Always keep your back straight and lift with your legs. Don't use the handles (if installed) to lift the chassis; the handles should only be used to pull the server out of the rack.
- Place the chassis top cover and any system components that have been removed away from the system or on a table so that they won't accidentally be stepped on.
- While working on the system, do not wear loose clothing such as neckties and unbuttoned shirt sleeves, which can come into contact with electrical circuits or be pulled into a cooling fan.
- Remove any jewelry or metal objects from your body, which are excellent metal conductors that can create short circuits and harm you if they come into contact with printed circuit boards or areas where power is present.

- After accessing the inside of the system, close the system back up and secure it to the rack unit with the retention screws after ensuring that all connections have been made.

4-3 ESD Precautions



Electrostatic discharge (ESD) is generated by two objects with different electrical charges coming into contact with each other. An electrical discharge is created to neutralize this difference, which can damage electronic components and printed circuit boards. The following measures are generally sufficient to neutralize this difference before contact is made to protect your equipment from ESD:

- Use a grounded wrist strap designed to prevent static discharge.
- Keep all components and printed circuit boards (PCBs) in their antistatic bags until ready for use.
- Touch a grounded metal object before removing the board from the antistatic bag.
- Do not let components or PCBs come into contact with your clothing, which may retain a charge even if you are wearing a wrist strap.
- Handle a board by its edges only; do not touch its components, peripheral chips, memory modules or contacts.
- When handling chips or modules, avoid touching their pins.
- Put the serverboard and peripherals back into their antistatic bags when not in use.
- For grounding purposes, make sure your computer chassis provides excellent conductivity between the power supply, the case, the mounting fasteners and the serverboard.

4-4 Operating Precautions



Care must be taken to assure that the chassis cover is in place when the 5046A-X is operating to assure proper cooling. Out of warranty damage to the 5046A-X system can occur if this practice is not strictly followed.

Figure 4-1. Installing the Onboard Battery

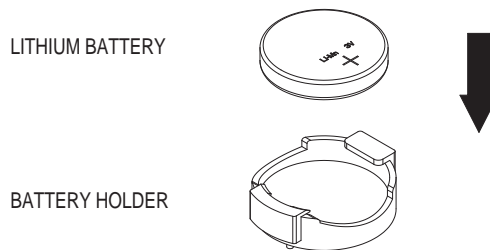

Please handle used batteries carefully. Do not damage the battery in any way; a damaged battery may release hazardous materials into the environment. Do not discard a used battery in the garbage or a public landfill. Please comply with the regulations set up by your local hazardous waste management agency to dispose of your used battery properly.

Chapter 5

Advanced Serverboard Setup

This chapter covers the steps required to install the C7X58 serverboard into the chassis, connect the data and power cables and install add-on cards. All serverboard jumpers and connections are also described. A layout and quick reference chart are included in this chapter for your reference. Remember to completely close the chassis when you have finished working with the serverboard to better cool and protect the system.

5-1 Handling the Serverboard

Electrostatic discharge (ESD) can damage electronic components. To prevent damage to any printed circuit boards (PCBs), it is important to handle them very carefully (see previous chapter). To prevent the serverboard from bending, keep one hand under the center of the board to support it when handling. The following measures are generally sufficient to protect your equipment from electric static discharge.

Precautions

- Use a grounded wrist strap designed to prevent Electrostatic Discharge.
- Touch a grounded metal object before removing any board from its antistatic bag.
- Handle a board by its edges only; do not touch its components, peripheral chips, memory modules or gold contacts.
- When handling chips or modules, avoid touching their pins.
- Put the serverboard, add-on cards and peripherals back into their antistatic bags when not in use.
- For grounding purposes, make sure your computer chassis provides excellent conductivity between the power supply, the case, the mounting fasteners and the serverboard.

Unpacking

The serverboard is shipped in antistatic packaging to avoid electrical static discharge. When unpacking the board, make sure the person handling it is static protected.

5-2 Serverboard Installation

This section explains the first step of physically mounting the C7X58 into the SC743TS-865BP-SQ chassis. Following the steps in the order given will eliminate the most common problems encountered in such an installation. To remove the serverboard, follow the procedure in reverse order.

Installing to the Chassis

1. Access the inside of the system by removing the screws from the back lip of the top cover of the chassis, then pull the cover off.
2. The C7X58 requires a chassis big enough to support a 12" x 10" serverboard, such as Supermicro's SC743TS-865BP-SQ.
3. Make sure that the I/O ports on the serverboard align properly with their respective holes in the I/O shield at the back of the chassis.
4. Carefully mount the serverboard to the serverboard tray by aligning the board holes with the raised metal standoffs that are visible in the chassis.
5. Insert screws into all the mounting holes on your serverboard that line up with the standoffs and tighten until snug (if you screw them in too tight, you might strip the threads). Metal screws provide an electrical contact to the serverboard ground to provide a continuous ground for the system.
6. Finish by replacing the top cover of the chassis.

5-3 Connecting Cables

Now that the serverboard is installed, the next step is to connect the cables to the board. These include the data (ribbon) cables for the peripherals and control panel and the power cables.

Connecting Data Cables

The cables used to transfer data from the peripheral devices have been carefully routed to prevent them from blocking the flow of cooling air that moves through the system from front to back. If you need to disconnect any of these cables, you should take care to keep them routed as they were originally after reconnecting them (make sure the red wires connect to the pin 1 locations). The following data cables (with their locations noted) should be connected. (See the layout on page 5-9 for connector locations.)

- SATA drive data cable (I-SATA0 ~ I-SATA3)
- Control Panel cable (JF1)
- SGPIO cable (SGPIO1)

Important! Make sure the the cables do not come into contact with the fans.

Connecting Power Cables

The C7X58 has a 24-pin primary power supply connector (JPW1) for connection to the ATX power supply. In addition, a 4-pin auxilliary power connector (JPW3) and an 8-pin processor power connector (JPW2) must also be connected to your power supply. See Section 5-9 for power connector pin definitions.

Connecting the Control Panel

JF1 contains header pins for various front control panel connectors. See Figure 5-1 for the pin locations of the various front control panel buttons and LED indicators.

All JF1 wires have been bundled into a single ribbon cable to simplify this connection. Make sure the red wire plugs into pin 1 as marked on the board. The other end connects to the Control Panel PCB board, located just behind the system status LEDs on the chassis. See Chapter 5 for details and pin descriptions.

Figure 5-1. Control Panel Header Pins

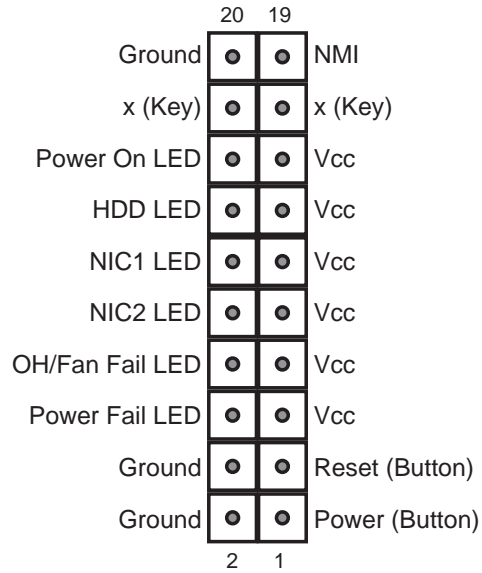

5-4 I/O Ports

The I/O ports are color coded in conformance with the PC 99 specification. See Figure 5-2 below for the colors and locations of the various I/O ports.

Figure 5-2. I/O Ports

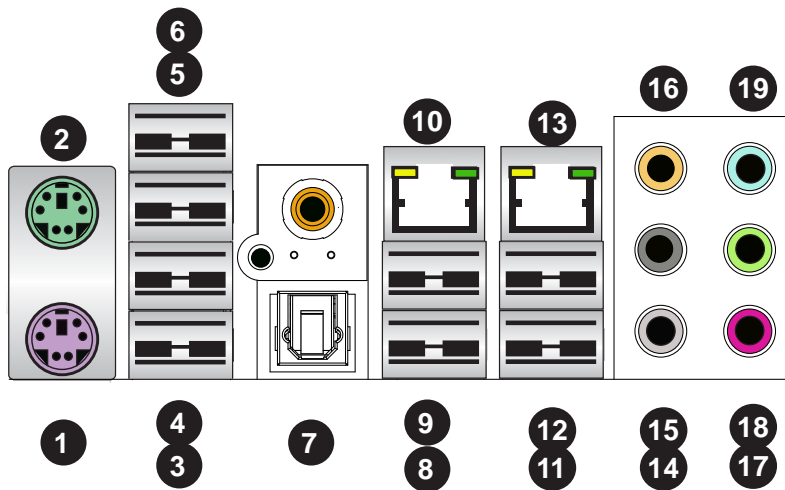

1. Keyboard (Purple)	11. USB Port 6
2. PS/2 Mouse (Green)	12. USB Port 7
3. USB Port 0	13. LAN2
4. USB Port 1	14. Side_Surround (Grey)
5. USB Port 2	15. Back_Surround (Black)
6. USB Port 3	16. CEN/LFE (Orange)
7. S/PDIF	17. Microphone-In (Pink)
8. USB Port 4	18. Front (Green)
9. USB Port 5	19. Line-In (Blue)
10. LAN 1	

5-5 Processor and Heatsink Installation



When handling the processor package, avoid placing direct pressure on the label area of the fan.

Notes:

1. Always connect the power cord last and always remove it before adding, removing or changing any hardware components. Make sure that you install the processor into the CPU socket before you install the CPU heatsink.
2. Intel's boxed processor package contains the CPU fan and heatsink assembly. If you buy a CPU separately, make sure that you use only Intel-certified multi-directional heatsink and fan.
3. Make sure to install the motherboard into the chassis before you install the CPU heatsink and heatsink fans.
4. When purchasing an LGA 1366 processor or when receiving a motherboard with an LGA 1366 processor pre-installed, make sure that the CPU plastic cap is in place, and none of the CPU pins are bent; otherwise, contact the retailer immediately.
5. Refer to the Supermicro web site for more details on CPU support.

Installing an LGA 1366 Processor

1. Press the socket clip to release the load plate, which covers the CPU socket, from its locking position.
2. Gently lift the socket clip to open the load plate.
3. Hold the plastic cap at its north and south center edges to remove it from the CPU socket.

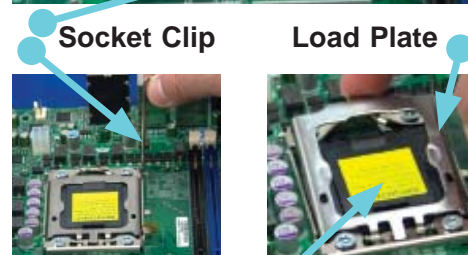

Hold the north & south edges of the plastic cap to remove it

1. After removing the plastic cap, using your thumb and the index finger, hold the CPU at the north and south center edges.
2. Align the CPU key (the semi-circle cutout) against the socket key (the notch below the gold color dot on the side of the socket).
3. Once both the CPU and the socket are aligned, carefully lower the CPU straight down into the socket. (Do not rub the CPU against the surface of the socket or its pins to avoid damaging the CPU or the socket.)
4. With the CPU inside the socket, inspect the four corners of the CPU to make sure that it is properly installed.
5. Once the CPU is securely seated in the socket, lower the CPU load plate to the socket.
6. Use your thumb to gently push the socket clip down to the clip lock.

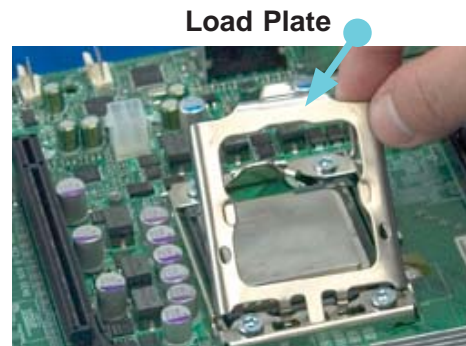
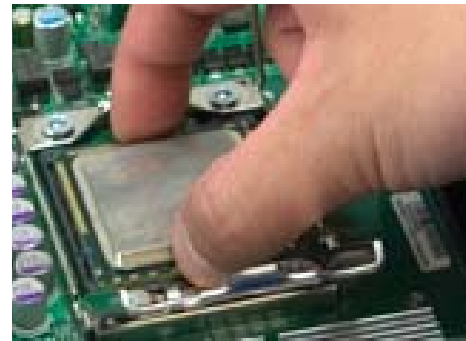
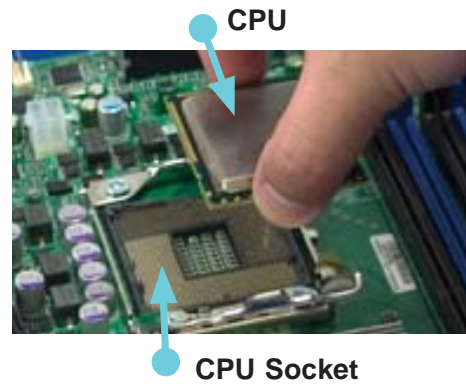

Warning: Please save the plastic cap. The motherboard must be shipped with the plastic cap properly installed to protect the CPU socket pins. Shipment without the plastic cap properly installed will cause damage to the socket pins.

Installation and Removal of the Heatsink

Installing the Heatsink Installation

1. Do not apply any thermal grease to the heatsink or the CPU die; the required amount has already been applied.
2. Place the heatsink on top of the CPU so that the four mounting holes are aligned with those on the retention mechanism.
3. Screw in two diagonal screws (i.e. the #1 and the #2 screws) until just snug (do not over-tighten the screws, which may damage the CPU.)
4. Finish the installation by fully tightening all four screws.

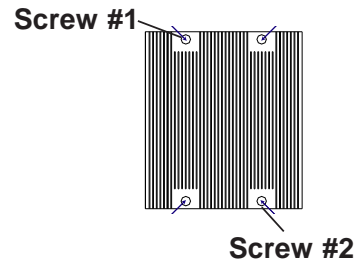

Uninstalling the Heatsink



Warning: We do not recommend removing the CPU or the heatsink. However, if you do need to uninstall the heatsink, please follow these instructions to avoid damaging the CPU or the CPU socket.

1. Unscrew and remove the heatsink screws in the sequence shown in the picture on the right.
2. Hold the heatsink as shown in the picture on the right and gently wriggle to loosen it from the CPU. (Do not use excessive force when doing this!)
3. Once the heatsink is loosened, remove it from the CPU socket.
4. Clean the surface of the CPU and the heatsink to get rid of the old thermal grease. Reapply the proper amount of thermal grease before you re-install the heatsink.

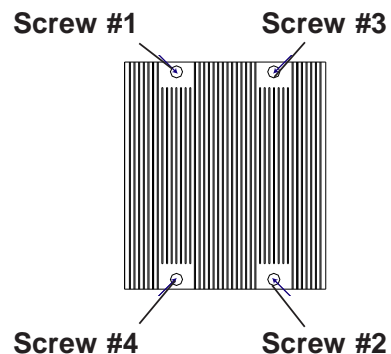

5-6 Installing Memory Modules

Note: Check the Supermicro web site for recommended memory modules.

CAUTION

Exercise extreme care when installing or removing DIMM modules to prevent any possible damage.

Installing & Removing DIMMs

1. Insert the desired number of DIMMs into the memory slots, starting with DIMM #1A. For best performance, please use the memory modules of the same type and speed in the same bank. See the DIMM Installation Chart on the following page.
2. Press down the release tabs on the ends of a memory slot. Insert each DIMM module vertically into its slot. Pay attention to the notch along the bottom of the module to prevent inserting the DIMM module incorrectly.
3. Gently press down on the DIMM module until it snaps into place in the slot. Repeat for all modules.
4. Reverse the steps above to remove the DIMM modules from the motherboard.

Press down the release tabs

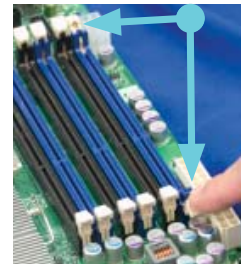

Insert & press a DIMM into the slot

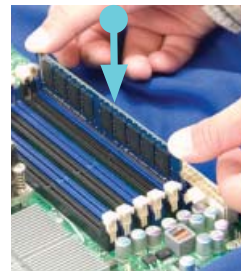
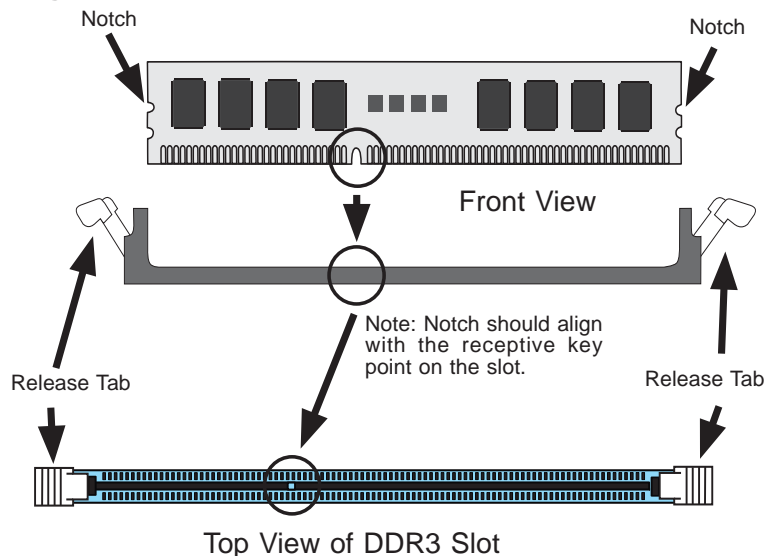

Figure 5-3. DIMM Installation

To Install: Insert module vertically and press down until it snaps into place. Pay attention to the alignment notch at the bottom.

To Remove: Use your thumbs to gently push the release tabs near both ends of the module. This should release it from the slot.



Memory Support

The C7X58 supports up to 24 GB of unbuffered ECC/non-ECC DDR3-1600-/1333/1066/800 SDRAM.

Notes:

- Due to the OS limitations, some operating systems may not show more than 4 GB of memory.
- Due to allocating memory to system devices, memory remaining available for operational use will be reduced when 4 GB of SDRAM is used. The reduction in memory availability is disproportional. (Refer to the following Memory Availability Table for details.)

Order of Populating DIMM Slots

For memory to work properly, follow the table below for the correct order of populating the DIMM slots. See the motherboard layout page for slot numbering.

DIMM Installation Chart						
Number of DIMMs	1A	2A	3A	1B	2B	3B
1	X					
2	X	X				
3	X	X	X			
4	X	X	X	X		
5	X	X	X	X	X	
6	X	X	X	X	X	X

Note: an "X" indicates the slot should be populated.

Population Rules

- Any combination of x8 and x16 UDIMMs, with 1Gb or 2Gb DRAM density.
- Populate DIMMs using the "A" DIMM slots first. Any of the slots may be used. Populate the "B" slots only after all "A" slots have been filled.

5-7 Adding PCI Add-On Cards

The 5046A-X can accommodate standard size add-on cards populated in all slots on the C7X58 serverboard.

Installing an Add-on Card

1. Begin by removing the PCI slot shield for the slot you wish to populate.
2. Fully seat the card into the riser card slot, pushing down with your thumbs evenly on both sides of the card.
3. Finish by using a screw to secure the top of the card shield to the chassis. The PCI slot shields protect the serverboard and its components from EMI and aid in proper ventilation, so make sure there is always a shield covering each unused slot.

5-8 Serverboard Details

Figure 5-4. C7X58 Layout

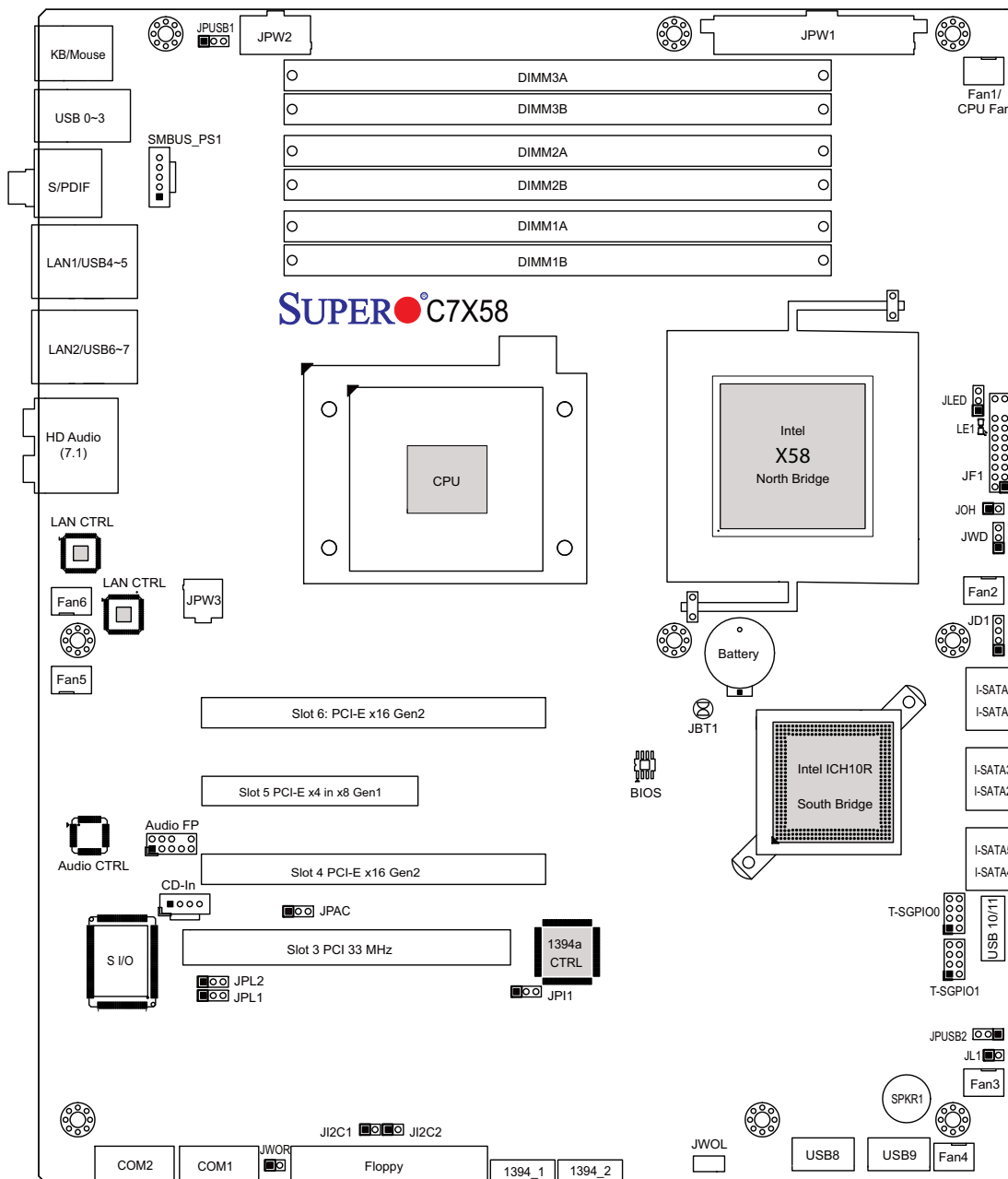

C7X58 Quick Reference

Jumper	Description	Default Setting
JBT1	CMOS Clear	(See Section 5-10)
J ² C1/J ² C2	SMB to PCI Slots	(See Section 5-10)
JPAC	Audio Enable/Disable	Pins 1-2 (Enabled)
JPI1	1394a_1/2 Enable/Disable	Pins 1-2 (Enabled)
JPL1/JPL2	LAN 1/2 Enable/Disable	Pins 1-2 (Enabled)
JUSB1	Backplane USB Enable/Disable	Pins 1-2 (Enabled)
JUSB2	Front Panel USB Enable/Disable	Pins 2-3 (Disabled)
JWD	Watch Dog Timer Enable/Disable	Pins 1-2 (Reset)

Connector	Description
1394a_1/2	IEEE 1394a (Firewire) Headers
Audio FP	Front Panel Audio Header
Audio (HD)	(BP) High Definition Audio (7.1) Ports
CD-In	Audio CD Input Header
COM1/COM2	COM1/2 Serial Port Connectors
Fan 1~6	Fan headers (Fan 1 = CPU fan)
Floppy	Floppy Disk Drive Connector
JD1	Speaker Header
JF1	Control Panel Header
JL1	Chassis Intrusion Header
JLED	Power LED Indicator Header
JOH1	Overheat LED Header
JPW1	24-pin ATX Main Power Connector
JPW2	+12V 8-pin CPU Power Connector
JPW3	+12V 4-pin Secondary Power Connector
JWOL	Wake-On-LAN Header
JWOR	Wake-On-Ring Header
LAN1/LAN2	Gigabit Ethernet (RJ45) ports
I-SATA 0~5	(Intel South Bridge) SATA ports 0/1, 2/3, 4/5
SMB_PS	PWR Supply (I ² C) System Management Bus
S/PDIF	Digital Audio/Video Interface Connector
T-SGPIO-0/1	Serial General Purpose Input/Output Headers
USB0~3, USB4/5, 6/7	Universal Serial Bus (USB) Ports
USB8, USB9, USB10/11	Front Panel Accessible USB Headers

5-9 Connector Definitions

Main ATX Power Supply Connector

The primary power supply connector (JPW1) meets the SSI (Superset ATX) 24-pin specification. Refer to the table on the right for the pin definitions of the ATX 24-pin power connector. You must also connect the 8-pin (JPW2) power connector to your power supply (see below).

ATX Power 24-pin Connector Pin Definitions (JPW1)			
Pin#	Definition	Pin #	Definition
13	+3.3V	1	+3.3V
14	-12V	2	+3.3V
15	COM	3	COM
16	PS_ON	4	+5V
17	COM	5	COM
18	COM	6	+5V
19	COM	7	COM
20	Res (NC)	8	PWR_OK
21	+5V	9	5VSB
22	+5V	10	+12V
23	+5V	11	+12V
24	COM	12	+3.3V

Processor Power Connector

JPW2 must also be connected to the power supply to provide power for the processor. See the table on the right for pin definitions.

8-pin (+12V) Processor Power Pin Definitions (JPW2)	
Pins	Definition
1 - 4	Ground
5 - 8	+12V

Required Connection

Secondary Power Connector

It is recommended that JPW3 be connected to the power supply to provide secondary power. See the table at right for pin definitions.

4-pin Secondary Power Pin Definitions (JPW3)	
Pins	Definition
1 and 2	Ground
3 and 4	+12V

Recommended Connection

Power Button

The connection for the power button is on pins 1 and 2 of JF1. The chassis power button should be connected here. See the table on the right for pin definitions.

Power Button Pin Definitions (JF1)	
Pin#	Definition
1	PW_ON
2	Ground

Reset Connector

The reset header is located on pins 3 and 4 of JF1. Attach the reset switch on the computer chassis to these pins. See the table on the right for pin definitions.

Reset Button Pin Definitions (JF1)	
Pin#	Definition
3	Reset
4	Ground

Overheat/Fan Fail LED (OH)

Connect an LED to pins 7 and 8 of JF1 to provide advanced warning of chassis overheating or fan failure. Refer to the table on the right for pin definitions.

OH/Fan Fail LED Pin Definitions (JF1)		OH/Fan Fail Indicator Status	
Pin#	Definition	State	Definition
7	Vcc	Off	Normal
8	Ground	On	Overheat
		Flash-ing	Fan Fail

NIC1 (GLAN) LED

The LED connections for the GB LAN port are on pins 11 and 12 of JF1. Attach an LED cable to display network activity. See the table on the right for pin definitions.

NIC1 LED Pin Definitions (JF1)	
Pin#	Definition
11	Vcc
12	Ground

HDD LED

The HDD LED connection is located on pins 13 and 14 of JF1. This LED is used to display all IDE and SATA activity. See the table on the right for pin definitions.

HDD LED Pin Definitions (JF1)	
Pin#	Definition
13	Vcc
14	HD Active

Power On LED

The Power On LED connector is located on pins 15 and 16 of JF1 (use JLED for a 3-pin connector). This connection is used to provide LED indication of power being supplied to the system. See the table on the right for pin definitions.

Power LED Pin Definitions (JF1)	
Pin#	Definition
15	5V Stby
16	Control

Chassis Intrusion

The Chassis Intrusion header is designated JL1. Attach an appropriate cable from the chassis to inform you of a chassis intrusion when the chassis is opened

Chassis Intrusion Pin Definitions (JL1)	
Pin#	Definition
1	Intrusion Input
2	Ground

ATX PS/2 Keyboard and PS/2 Mouse Ports

The ATX PS/2 keyboard and the PS/2 mouse are located on the I/O back-panel. The mouse port is above the keyboard port. See the table on the right for pin definitions.

PS/2 Keyboard and Mouse Port Pin Definitions	
Pin#	Definition
1	Data
2	NC
3	Ground
4	VCC
5	Clock
6	NC

Fan Headers

The C7X58 has six fan headers, all of which are 4-pin fans. However, pins 1-3 of the fan headers are backward compatible with the traditional 3-pin fans. See the table on the right for pin definitions. The onboard fan speeds are controlled by Thermal Management (via Hardware Monitoring) under the Advanced Section in the BIOS. The default is disabled. When using Thermal Management setting, please use all 3-pin fans or all 4-pin fans.

Fan Header Pin Definitions (FAN1-6)	
Pin#	Definition
1	Ground (Black)
2	+12V (Red)
3	Tachometer
4	PWM Control

LAN1/LAN2 (Ethernet Ports)

Two Ethernet ports are located on the I/O backplane. These ports accept RJ45 type cables.



Wake-On-LAN

The Wake-On-LAN header is designated JWOL on the serverboard. See the table on the right for pin definitions. You must also have a LAN card with a Wake-On-LAN connector and cable to use this feature.

Wake-On-LAN Pin Definitions (JWOL)	
Pin#	Definition
1	+5V Standby
2	Ground
3	Wake-up

Wake-On-Ring

The Wake-On-Ring header is designated JWOR. This function allows your computer to receive and be "awakened" by an incoming call when in the suspend state. See the table on the right for pin definitions. You must also have a WOR card and cable to use this feature.

Wake-On-Ring Pin Definitions (JWOR)	
Pin#	Definition
1	Ground (Black)
2	Wake-up

Speaker

On the JD1 header, pins 3~4 are used for the internal speaker. Close pins 3~4 with a cap to use the onboard speaker. If you wish to use an external speaker, connect the speaker cable to pins 1~4. See the table on the right for pin definitions.

Speaker Connector Pin Definitions (JD1)	
Pin Setting	Definition
Pins 3~4	Internal Speaker
Pins1~4	External Speaker

Serial Ports

Two serial ports are included on the C7X58. See the table on the right for pin definitions.

Serial Port Pin Definitions (COM1/COM2)			
Pin #	Definition	Pin #	Definition
1	DCD	6	DSR
2	RXD	7	RTS
3	TXD	8	CTS
4	DTR	9	RI
5	Ground	10	NC

SGPIO Header

Two SGPIO (Serial General Purpose Input/Output) headers are designated SGPIO0 and SGPIO1. These headers are used to communicate with the system's enclosure management chip. See the table on the right for pin definitions.

SGPIO Header Pin Definitions (T-SGPIO0/T-SGPIO1)			
Pin#	Definition	Pin	Definition
1	NC	2	NC
3	Ground	4	DATA Out
5	Load	6	Ground
7	Clock	8	NC

NC = No Connection

CD and Audio FP

A 4-pin CD header (CD-IN) and an auxiliary header (Audio FP) allow you to use the onboard sound for audio CD playback. Connect an audio cable from your CD drive to the header that fits your cable's connector. Only one header can be used at any one time. See the tables at right for pin definitions.

Audio Input CD Header Pin Definitions (CD-IN)	
Pin#	Definition
1	Left Stereo Signal
2	Ground
3	Ground
4	Right Stereo Signal

Front Panel Audio Control

When front panel headphones are plugged in, the back panel audio output is disabled. This is done through the FP Audio header (Audio FP). If the front panel interface card is not connected to the front panel audio header, jumpers should be installed on pin pairs 1-2, 5-6, and 9-10 of the Audio FP header. If these jumpers are not installed, the back panel line out connector will be disabled, and pin 1 of the microphone in will be left floating, which can lead to excessive back panel microphone noise and crosstalk. See the table at right for pin definitions.

Front Panel Audio Pin Definitions (Audio FP)	
Pin#	Definition
1	MIC_L
2	Audio Ground
3	MIC_R
4	FP Audio Detect
5	Line_2_R
6	Ground
7	FP_Jack Detect
8	Key
9	Line_2_L
10	Ground

High Definition Audio (HDA)

The C7X58 features a 7.1+2 Channel High Definition Audio (HDA) codec that provides 10 DAC channels, simultaneously supporting 7.1 sound playback and two channels of independent stereo sound output (multiple streaming) through the front panel stereo out via the front L&R, rear L&R, center and subwoofer speakers. This feature is activated with the software included in the CD-ROM that came with your motherboard. Sound is output through the Line In, Line Out and MIC jacks.

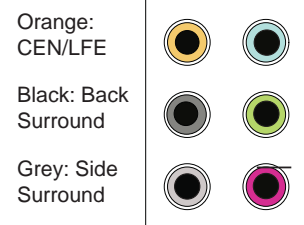

IEEE 1394 Connection

Connectors 1394_1 and 1394_2 provide connectivity for IEEE 1394 (Firewire) devices. See the tables on the right for pin definitions.

1394_1 Pin Definitions			
Pin#	Defin.	Pin#	Defin
1	PTPA0+	2	PTPA0-
3	GND	4	GND
5	PTPB0+	6	PTPB0-
7	PWR 1394	8	PWR 1394
		10	ZX

1394_2 Pin Definitions			
Pin#	Defin.	Pin#	Defin
1	PTPA1+	2	PTPA1-
3	GND	4	GND
5	PTPB1+	6	PTPB1-
7	PWR 1394	8	PWR 1394
		10	ZY

Universal Serial Bus (USB)

Eight Universal Serial Bus ports (USB 0~3, USB 4/5, USB 6/7) are located on the I/O back panel. USB Ports 4/5 are located below LAN Port1 port. USB 6/7 are below LAN Port2. An additional four USB connections (USB 8, USB 9 and USB 10/11) are used to provide front chassis access. USB 8 and USB 9 are Type A connectors. (USB cables not included). See the tables on the right for pin definitions.

Back Panel USB 0~3, 4/5, 6/7 Pin Definitions			
Pin#	Definition	Pin#	Definition
1	+5V	5	+5V
2	USB_PN1	6	USB_PN0
3	USB_PP1	7	USB_PP0
4	Ground	8	Ground

Front Panel USB 8, 9, 10~11 Pin Definitions			
USB 8, 9, 10		USB 11	
Pin #	Definition	Pin #	Definition
1	+5V	6	+5V
2	USB_PN2	7	USB_PN3
3	USB_PP2	8	USB_PP3
4	Ground	9	Ground
5	No Con- nection	10	Key

S/PDIF_Out Connector

An S/PDIF_Out connector is located next to the Backpanel USB ports on the motherboard. The S/PDIF(Sony/Philips Digital Interface Format) connector is used for transporting stereo digital audio signals. It is commonly used to connect the output of a DVD player to a home theater receiver that supports Dolby Digital or DTS surround sound. The S/PDIF_Out connector includes the top component (S/PDIF_RCA) and the bottom component (S/PDIF). See the tables below for pin definitions.

Overheat/Fan Fail LED (JOH1)

The JOH1 header is used to connect an LED to provide warnings of chassis overheat. This LED will also blink to indicate a fan failure. Refer to the table on right for pin definitions.

Overheat LED Pin Definitions	
Pin#	Definition
1	5vDC
2	OH Active

Power Supply I²C Connector

The Power Supply (I²C) connector can be used to monitor the status of the power supply, fan and system temperature. See the table on the right for pin definitions.

PWR Supply I ² C Pin Definitions (SMB_PS)	
Pin#	Definition
1	Clock
2	Data
3	PWR Fail
4	Ground

5-10 Jumper Settings

Explanation of Jumpers

To modify the operation of the serverboard, jumpers can be used to choose between optional settings. Jumpers create shorts between two pins to change the function of the connector. Pin 1 is identified with a square solder pad on the printed circuit board. See the serverboard layout pages for jumper locations.

Note: On a two-pin jumper, "Closed" means the jumper is on both pins and "Open" means the jumper is either on only one pin or completely removed.

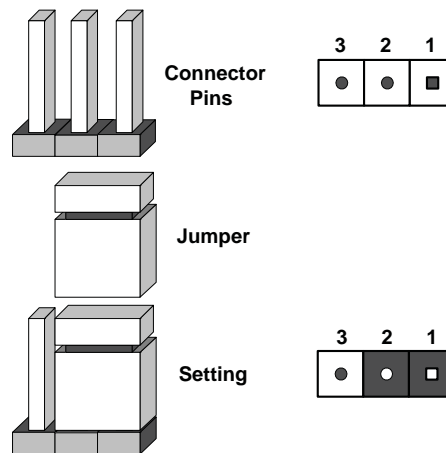

CMOS Clear

JBT1 is used to clear CMOS (which will also clear any passwords). Instead of pins, this jumper consists of contact pads to prevent accidentally clearing the contents of CMOS.

To clear CMOS,

1. First power down the system and unplug the power cord(s).
2. With the power disconnected, short the CMOS pads with a metal object such as a small screwdriver.
3. Remove the screwdriver (or shorting device).
4. Reconnect the power cord(s) and power on the system.

Note: Do not use the PW ON connector to clear CMOS.

LAN1/LAN2 Enable/Disable

Change the setting of jumper JPL1 or JPL2 to enable or disable the LAN1 and LAN2 Ethernet ports, respectively. See the table on the right for jumper settings. The default setting is enabled.

LAN1/LAN2 Enable/Disable Jumper Settings (JPL1/JPL2)	
Jumper Setting	Definition
Pins 1-2	Enabled
Pins 2-3	Disabled

Audio Enable/Disable

JPAC enables or disables the onboard audio connections. See the table on the right for jumper settings. The default setting is Enabled.

Audio Enable/Disable Jumper Settings (JP5)	
Pin#	Definition
1-2	Enabled
2-3	Disabled

SMBus to PCI/PCI-E Slots

Jumpers JI²C1 and JI²C2 allow you to connect the PCI slots to the System Management Bus (I²C). The default setting is disabled. See the table on the right for jumper settings.

SMBus to PCI Slots Jumper Settings (JI ² C1/JI ² C2)	
JI ² C1/ JI ² C2	Setting
Pins 1-2	Enabled
Pins 2-3	Disabled

Watch Dog Enable/Disable

JWD controls the Watch Dog function. Watch Dog is a system monitor that can reboot the system when a software application hangs. Jumping pins 1-2 will cause WD to reset the system if an application hangs. Jumping pins 2-3 will generate a non-maskable interrupt signal for the application that hangs. See the table on the right for jumper settings. Watch Dog must also be enabled in BIOS.

Watch Dog Jumper Settings (JWD)	
Jumper Setting	Definition
Pins 1-2	Reset
Pins 2-3	NMI
Open	Disabled

Note: When enabled, the user needs to write their own application software in order to disable the Watch Dog Timer.

USB Wake-Up Enable/Disable

Use the JPUSB1/2 jumpers to allow the system to be "Woken Up" via USB devices by pressing a key on the USB keyboard or by clicking the USB mouse of your system. These jumpers are used together with the USB Wake-Up function in the BIOS. Enable the jumper and the BIOS setting to use this feature. See the table on the right for jumper settings.

Note: JPUSB1 is used for USB ports #0~7, and JPUSB2 is for Front Panel USB ports #8, #9 and #10~11. The default jumper setting is Enabled for JUSB1 and disabled for JUSB2. However, when the USB function is Enabled in the BIOS, please be sure to remove those USB devices from the USB ports whose USB jumpers are set to Disabled before the system goes into the standby mode.

USB Wake-Up Enable/Disable Jumper Settings (JUSB1/JUSB2)	
Pin#	Definition
1-2	Enabled
2-3	Disabled

IEEE 1394a Enable/Disable

JPI1 allows the user to use the onboard IEEE 1394_1 and 1394_2 connections. Close pins 1-2 to use this function. The default setting is Enabled.

1394a Enable Jumper Settings	
Pin#	Definition
1-2	Enabled (default)
2-3	Disabled

5-11 Onboard Indicators

LAN1/2 LEDs

The Ethernet ports (located beside the VGA port) have two LEDs. On each port, one LED indicates activity while the other LED may be green, amber or off to indicate the speed of the connection. See the table on the right for the functions associated with the connection speed LED.

LAN1/2 LED (Connection Speed Indicator)	
LED Color	Definition
Off	No Connection or 10 MHz
Green	100 MHz
Amber	1 GHz

Onboard Power LED (LE1)

An Onboard Power LED is located at LE1 on the motherboard. When LE1 is on, the AC power cable is connected. Make sure to disconnect the power cable before removing or installing any component. See the table on the right for more details.

Onboard PWR LED Indicator (LE1)	
LED State	Definition
Off	System Off
On	System On or System Off and Power Cable is Connected

5-12 Floppy and SATA Ports

SATA Ports

Six Serial ATA (SATA) ports (I-SATA 0~5) are located on the motherboard to provide serial link connections. Serial Link connections provide faster data transmission than those of the traditional Parallel ATA. These SATA ports are supported by the Intel ICH10R Chip (South Bridge). See the table on the right for pin definitions.

SATA Port Pin Definitions (I-SATA0 ~ I-SATA5)	
Pin #	Definition
1	Ground
2	TXP
3	TXN
4	Ground
5	RXN
6	RXP
7	Ground

Floppy Connector

The floppy connector is located between the COM port and FireWire headers on the motherboard. See the table on the right for pin definitions.

Note the following when connecting the floppy cable:

- The floppy disk drive cable has seven twisted wires.
- A red mark on a wire typically designates the location of pin 1.
- A single floppy disk drive ribbon cable has 34 wires and two connectors to provide for two floppy disk drives. The connector with twisted wires always connects to drive A, and the connector that does not have twisted wires always connects to drive B.

Floppy Drive Connector Pin Definitions (Floppy)			
Pin#	Definition	Pin #	Definition
1	Ground	2	FDHDIN
3	Ground	4	Reserved
5	Key	6	FDEDIN
7	Ground	8	Index
9	Ground	10	Motor Enable
11	Ground	12	Drive Select B
13	Ground	14	Drive Select B
15	Ground	16	Motor Enable
17	Ground	18	DIR
19	Ground	20	STEP
21	Ground	22	Write Data
23	Ground	24	Write Gate
25	Ground	26	Track 00
27	Ground	28	Write Protect
29	Ground	30	Read Data
31	Ground	32	Side 1 Select
33	Ground	34	Diskette

Chapter 6

Advanced Chassis Setup

This chapter covers the steps required to install components and perform simple maintenance on the SC743TS-865BP-SQ chassis. Following the component installation steps in the order given will eliminate most common problems. If some steps are unnecessary, skip ahead to the step that follows. Refer to Chapter 2 for instructions on installing the system as a 4U rackmount.

Tools Required: The only tool you will need is a Philips screwdriver.

6-1 Static-Sensitive Devices

Static electrical discharge can damage electronic components. To prevent damage to any printed circuit boards (PCBs), it is important to handle them very carefully. The following measures are generally sufficient to protect your equipment from static discharge.

Precautions

- Use a grounded wrist strap designed to prevent static discharge.
- Touch a grounded metal object before removing any board from its antistatic bag.
- Handle a board by its edges only; do not touch its components, peripheral chips, memory modules or gold contacts.
- When handling chips or modules, avoid touching their pins.
- Put the serverboard, add-on cards and peripherals back into their antistatic bags when not in use.
- For grounding purposes, make sure your computer chassis provides excellent conductivity between the power supply, the case, the mounting fasteners and the serverboard.

Unpacking

The serverboard is shipped in antistatic packaging. When unpacking the board, make sure the person handling it is static protected.

Figure 6-1. Chassis Front View

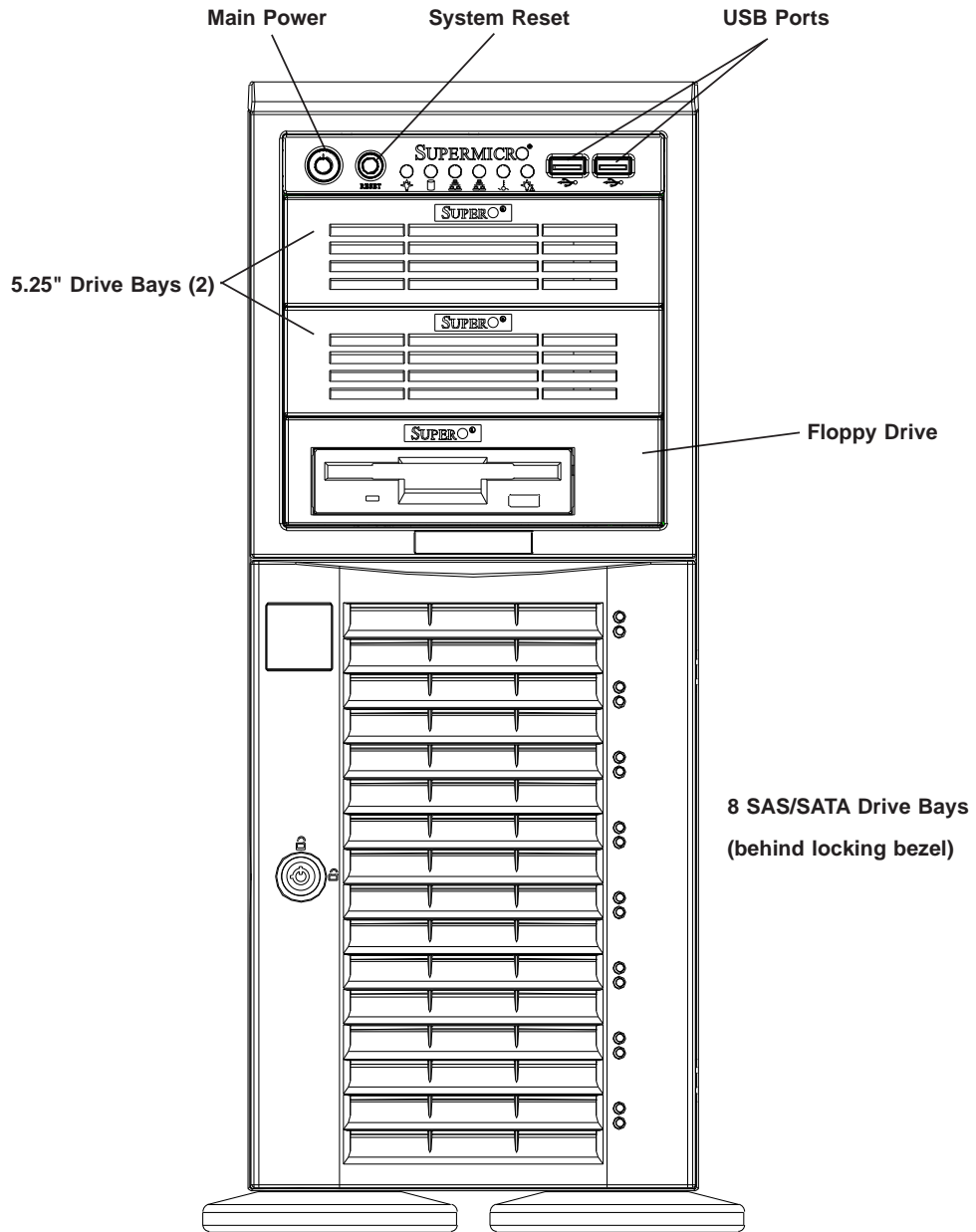







6-2 Front Control Panel

The front control panel must be connected to the JF1 connector on the serverboard to provide you with system status and alarm indications. A ribbon cable has bundled these wires together to simplify this connection.

Connect the cable from JF1 on the serverboard (making sure the red wire plugs into pin 1) to the appropriate connector on the front control panel PCB (printed circuit board). Pull all excess cabling over to the control panel side of the chassis. The LEDs on the control panel inform you of system status - see Figure 6-2 for details. See Chapter 5 for details on JF1.

Figure 6-2. Front Control Panel LEDs

Power		Indicates power is being supplied to the system.
HDD		Indicates IDE device and hard drive activity. On the SC743TS-865BP-SQ, this LED indicates SAS/SATA hard drive activity when flashing.
NIC1		Indicates network activity on LAN port 1.
NIC2		Indicates network activity on LAN port 2
Overheat/Fan Fail		When this LED flashes, it indicates a fan failure. When on continuously it indicates an overheat condition (see Chapter 3 for details).
Power Fail		Indicates a power supply fan failure. An alarm will also sound, which can be turned off with the reset switch on the back of the power supply.

6-3 System Fans

Two 8-cm PWM chassis fans provide air intake while one 9-cm PWM exhaust fan expels hot air from the chassis. All are low-noise fans that result in "Whisper-Quiet" operation (~28 dB). The chassis is also fitted with an air shroud to concentrate the flow of cooling air through the system. The fans should be connected to headers on the serverboard (see Chapter 5).

The power supply includes redundant cooling fans. If one fan fails, the rpm of the remaining fan will ramp up its rpm to provide sufficient cooling. The Power Fail LED will illuminate and an audible alarm will sound, which can be silenced with a button on the power supply. If a power supply fan fails, you should replace the power supply at your earliest convenience.

Fan Failure

Under normal operation, the chassis fans, the exhaust fan and the power supply fans run continuously. The chassis fans are hot-pluggable and can be replaced without powering down the system.

Replacing Chassis Cooling Fans

Removing a Fan

1. First locate the failed chassis fan by removing the top/left chassis cover (see Chapter 2 for details). Locate the fan that has stopped working.
2. Depress the locking tab on the failed fan: on a chassis fan, push the tab on the side of the housing inward, on the exhaust fan push down on the colored tab.
3. With the tab depressed, pull the unit straight out (see Figure 6-3). The wiring for these fans has been designed to detach automatically.

Installing a New Fan

1. Replace the failed fan with an identical one (available from Supermicro)
2. Install it in the same position and orientation as the one you removed; it should click into place when fully inserted.
3. Check that the fan is working then replace the top/left side chassis panel.

Figure 6-3. Removing a Chassis Fan

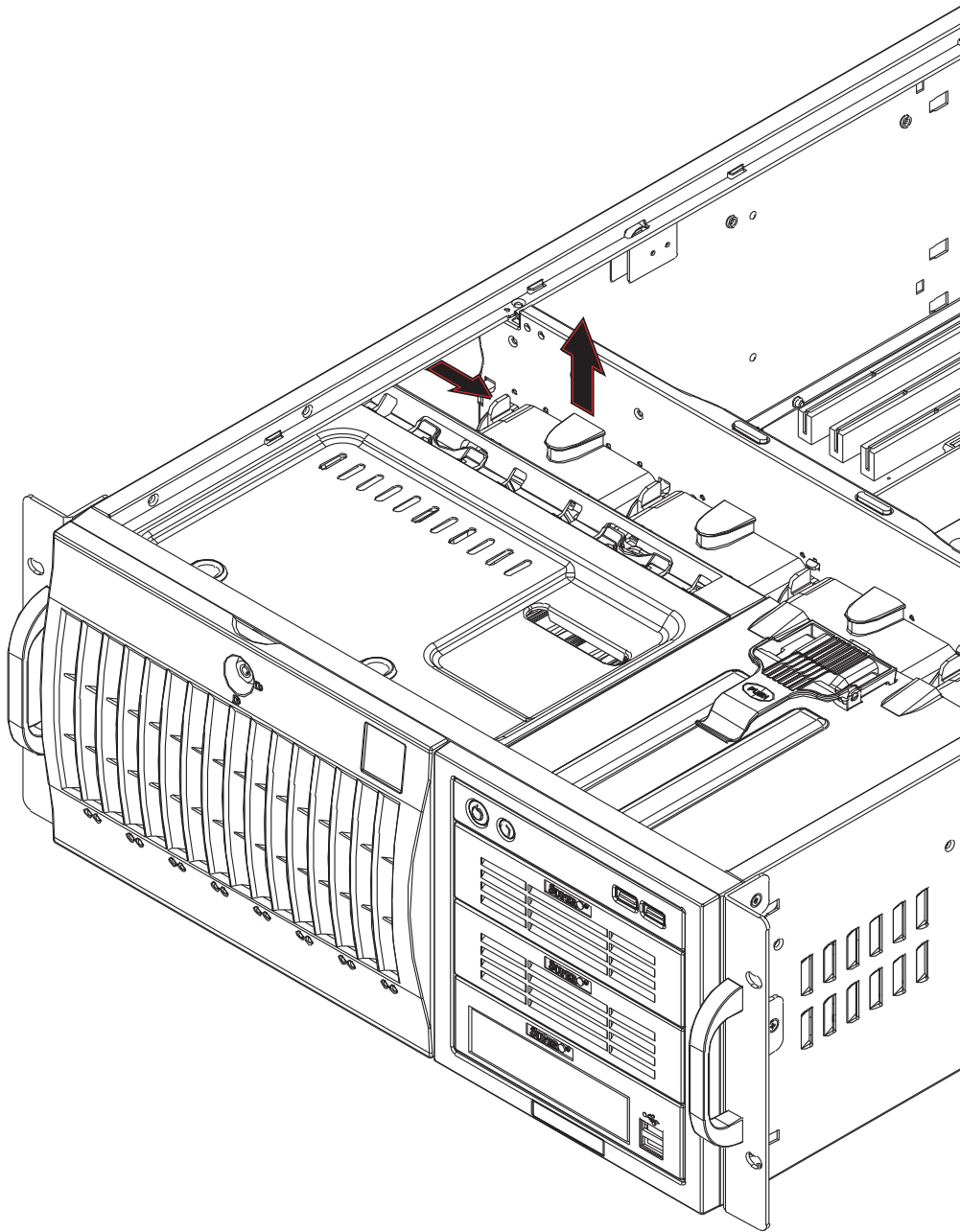

6-4 Drive Bay Installation

A total of eight SAS (or six SATA) drives may be housed in the SC743TS-865BP-SQ chassis. The drive IDs are preconfigured as 0 through 7 (or 5) in order from bottom to top (or from left to right if rackmounted). A bezel covers the drive area but does not need to be removed to access the drives; simply swing open the bezel. If you wish to remove the bezel piece, push on the three tabs on the inside of the left lip of the front chassis cover. Then slightly swing out the same (left) side of the cover - about ½ inch only. Remove by pushing on the open side of the cover to remove it from the chassis (do not try to swing or pull it straight out after opening the left side).



Regardless of how many SAS/SATA drives are installed, all drive carriers must remain in the drive bays to promote proper airflow.

Installing/Removing SAS/SATA Drives

The SAS/SATA drive carriers are all easily accessible at the front of the chassis. These drives are hot-swappable, meaning they can be removed and installed without powering down the system.

1. Open the front bezel then push the release button located beside the drive LEDs.
2. Swing the handle fully out and then use it to pull the unit straight out.

Note: Your operating system must have RAID support to enable the hot-swap capability of the SAS/SATA drives.

Mounting a SAS/SATA drive in a Drive Carrier

The SAS/SATA drive carriers help to promote proper airflow for the system. For this reason, even carriers without SAS/SATA drives must remain in the chassis.

1. Insert the drive into the carrier with the printed circuit board side facing down so that the mounting holes align with those in the carrier.
2. Secure the drive to the carrier with four screws (see Figure 6-5).

Figure 6-4. Removing a SAS/SATA Drive Carrier

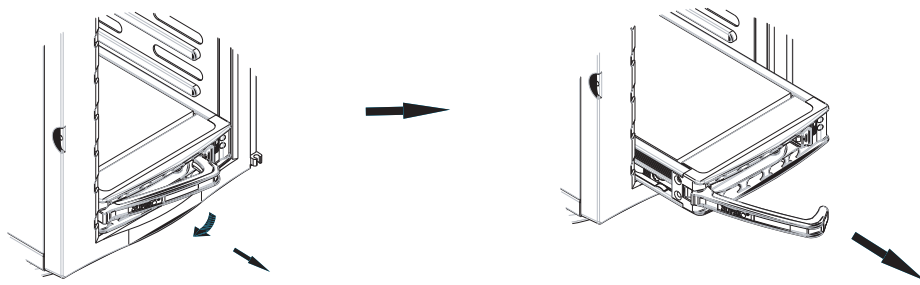
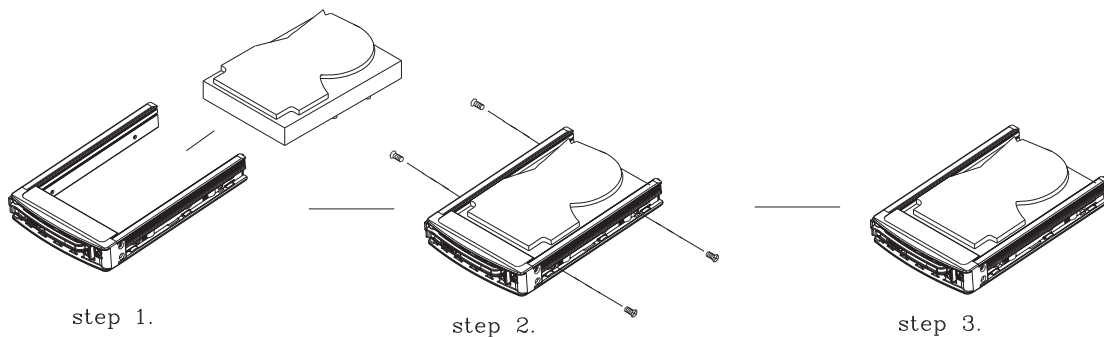

Figure 6-5. Mounting a SAS/SATA Drive in a Carrier



Important! Use extreme caution when working around the SAS/SATA backplane. Do not touch the backplane with any metal objects and make sure no ribbon cables touch the backplane or obstruct the airflow holes.

SAS/SATA Backplane

The SAS/SATA drives plug into a SAS/SATA backplane. A data cable (CBL-061L) for each drive and two SAS/SATA LED cables (CBL-0157L) need to be connected from the serverboard to the appropriate connectors on the backplane. You cannot cascade the SAS/SATA backplane.

Installing Components in the 5.25" Drive Bays

The 5046A-X has two 5.25" drive bays. Components such as an extra floppy drive, IDE hard drives or DVD/CD-ROM drives can be installed into these 5.25" drive bays.

Removing the Empty Drive Bay

1. First power down the system.
2. Remove the top/left chassis cover to access the drive components.
3. With the cover off, remove the screws that secure the drive carrier to the chassis (one side only) then push the entire empty drive carrier out from the back.

Adding a DVD/CD-ROM Drive

1. Remove the guide plates (one on each side) from the empty drive carrier and screw them into both sides of the DVD/CD-ROM drive using the holes provided.
2. Slide the DVD/CD-ROM into the bay and secure it to the chassis with the drive carrier screws you first removed.
3. Attach the power and data cables to the drive.
4. Replace the top/left chassis cover and restore power to the system.

Adding an IDE or Floppy Drive

1. Install an IDE or floppy into one of the removed empty drive carriers with the printed circuit board side toward the carrier so that the drive's mounting holes align with those in the carrier.
2. Secure the drive to the carrier with screws then slide the assembly into the bay and secure it to the chassis with the drive carrier screws you first removed.
3. Attach the power and data cables to the drive.
4. Replace the top/left chassis cover and restore power to the system.

Note: A red wire typically designates the location of pin 1. Drive carriers should remain in any empty drive bays to maintain proper airflow within the chassis.

6-5 Power Supply

The SuperWorkstation 5046A-X has a single 865 watt power supply. This power unit is equipped with low-noise technology, making the system ideal for workstation environments.

The power supply has an auto-switching capability that enable it to automatically sense and operate with 100 or 240 volt inputs.

Power Supply Failure

If the power supply unit fails, the system will shut down and you will need to replace the power supply unit. Replace with the same model - PWS-865-PQ, which can be ordered directly from Supermicro (see Contact Information in the Preface). As there is only one power supply unit, the system must be powered down before removing and/or replacing the power supply for whatever reason.

Replacing the Power Supply

1. First power down the system.
2. Unplug the power cord from the power supply module.
3. Remove the screws that secure the module to the chassis then pull it completely out.
4. Replace the failed unit with another unit of the exact same part number (PWS-865-PQ).
5. Gently but firmly push the new unit all the way into the open bay.
6. Secure it to the chassis using the screws you previously removed.
7. Finish by replacing the chassis left/top cover and then plugging the power cord back into the new module you just added.
8. Push the power button to restart the system.

Notes

Chapter 7

BIOS

7-1 Introduction

This chapter describes the AMI BIOS Setup Utility for the C7X58. The AMI ROM BIOS is stored in a Flash EEPROM and can be easily updated. This chapter describes the basic navigation of the AMI BIOS Setup Utility setup screens.

Starting BIOS Setup Utility

To enter the AMI BIOS Setup Utility screens, press the <Delete> key while the system is booting up.



Note: In most cases, the <Delete> key is used to invoke the AMI BIOS setup screen. There are a few cases when other keys are used, such as <F1>, <F2>, etc.

Each main BIOS menu option is described in this manual. The Main BIOS setup menu screen has two main frames. The left frame displays all the options that can be configured. Grayed-out options cannot be configured. Options in blue can be configured by the user. The right frame displays the key legend. Above the key legend is an area reserved for a text message. When an option is selected in the left frame, it is highlighted in white. Often a text message will accompany it. (**Note:** the AMI BIOS has default text messages built in. Supermicro retains the option to include, omit, or change any of these text messages.)

The AMI BIOS Setup Utility uses a key-based navigation system called hot keys. Most of the AMI BIOS setup utility hot keys can be used at any time during the setup navigation process. These keys include <F1>, <F10>, <Enter>, <ESC>, arrow keys, etc.



Note: Options printed in **Bold** are default settings.

How To Change the Configuration Data

The configuration data that determines the system parameters may be changed by entering the AMI BIOS Setup utility. This Setup utility can be accessed by pressing at the appropriate time during system boot.

Starting the Setup Utility

Normally, the only visible POST (Power On Self Test) routine is the memory test. As the memory is being tested, press the <Delete> key to enter the main menu of the AMI BIOS Setup Utility. From the main menu, you can access the other setup screens. An AMI BIOS identification string is displayed at the left bottom corner of the screen, below the copyright message.



Warning!! Do not shut down or reset the system while updating BIOS to prevent possible boot failure.

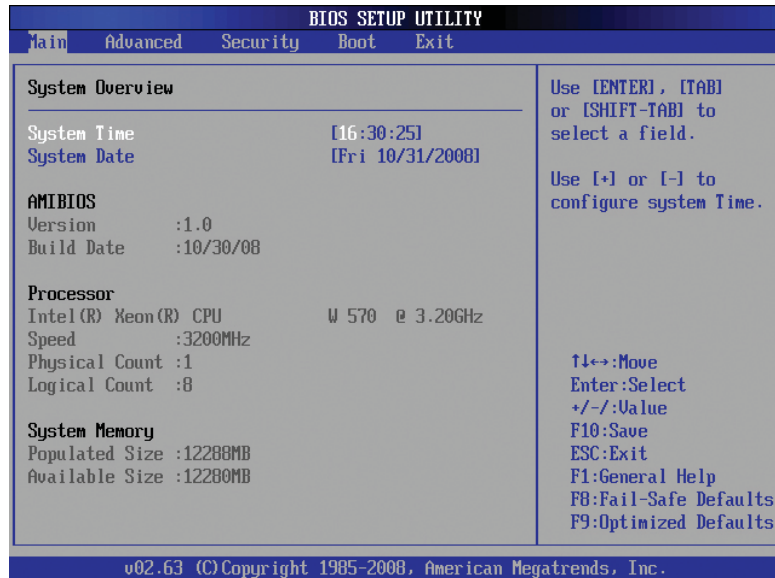

7-2 Main Setup

When you first enter the AMI BIOS Setup Utility, you will enter the Main setup screen. You can always return to the Main setup screen by selecting the Main tab on the top of the screen. The Main BIOS Setup screen is shown below.

System Overview: The following BIOS information will be displayed:

System Time/System Date

Use this option to change the system time and date. Highlight *System Time* or *System Date* using the arrow keys. Enter new values through the keyboard. Press the <Tab> key or the arrow keys to move between fields. The date must be entered in Day MM/DD/YY format. The time is entered in HH:MM:SS format. (**Note:** The time is in the 24-hour format. For example, 5:30 P.M. appears as 17:30:00.)

AMIBIOS

Version

Build Date

Processor

The AMI BIOS will automatically display the status of processor as shown below:

Speed

Physical Count

Logical Count

System Memory

This displays the size of memory available in the system:

Populated Size

Available Size

7-3 Advanced Setup Configurations

Use the arrow keys to select Boot Setup and hit <Enter> to access the submenu items:

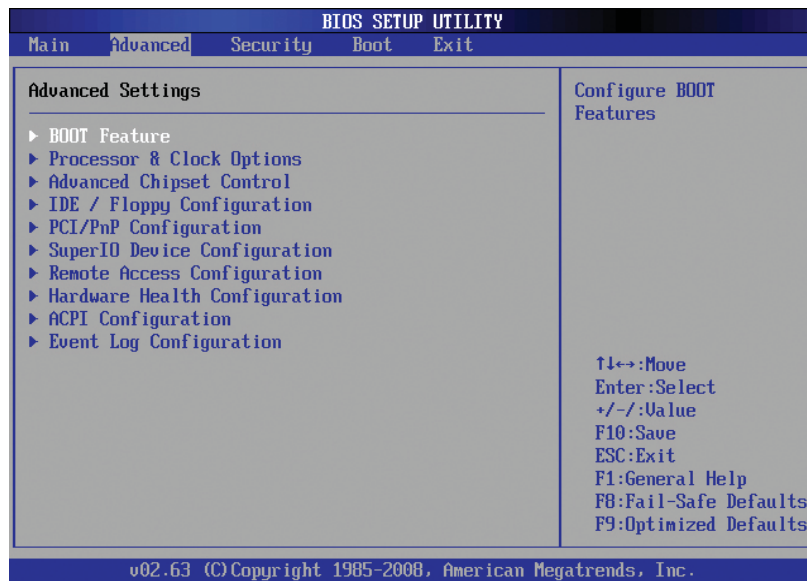

► BOOT Feature

Quick Boot

If Enabled, this option will skip certain tests during POST to reduce the time needed for system boot. The options are **Enabled** and Disabled.

Quiet Boot

This option allows the bootup screen options to be modified between POST messages or the OEM logo. Select Disabled to display the POST messages. Select Enabled to display the OEM logo instead of the normal POST messages. The options are **Enabled** and Disabled.

AddOn ROM Display Mode

This sets the display mode for Option ROM. The options are **Force BIOS** and Keep Current.

Bootup Num-Lock

This feature selects the Power-on state for Numlock key. The options are Off and **On**.

PS/2 Mouse Support

This feature enables support for the PS/2 mouse. The options are Disabled, Enabled and **Auto**.

Wait For 'F1' If Error

This forces the system to wait until the 'F1' key is pressed if an error occurs. The options are Disabled and **Enabled**.

Hit 'Del' Message Display

This feature displays "Press DEL to run Setup" during POST. The options are **Enabled** and Disabled.

Watch Dog Function

If enabled, the Watch Dog Timer will allow the system to reboot when it is inactive for more than 5 minutes. The options are Enabled and **Disabled**.

Restore on AC Power Loss

Use this feature to set the power state after a power outage. Select Power-Off for the system power to remain off after a power loss. Select Power-On for the system power to be turned on after a power loss. Select Last State to allow the system to resume its last state before a power loss. The options are Power-On, Power-Off and **Last State**.

Interrupt 19 Capture

Interrupt 19 is the software interrupt that handles the boot disk function. When this item is set to Enabled, the ROM BIOS of the host adaptors will "capture" Interrupt 19 at boot and allow the drives that are attached to these host adaptors to function as bootable disks. If this item is set to Disabled, the ROM BIOS of the host adaptors will not capture Interrupt 19, and the drives attached to these adaptors will not function as bootable devices. The options are Enabled and **Disabled**.

► Processor & Clock Options



When you first enter the Processor and Clock Options, the current processor and clock configuration is displayed. Below it are the different options that can be modified:

Ratio CMOS Setting

This option allows the user to set the ratio between the CPU Core Clock and the FSB Frequency. (**Note:** if an invalid ratio is entered, the AMI BIOS will restore the setting to the previous state.) The default setting depends on what type of CPU is installed. For example, the default setting for the Intel® Core i7™ 965 is **[24]**. Press "+" or "-" on your keyboard to change this value.

Clock-Spread Spectrum

Select Enable to use the feature of Clock Spectrum, which will allow the BIOS to monitor and attempt to reduce the level of Electromagnetic Interference caused by the components whenever needed. The options are **Disabled** and **Enabled**.

Hardware Prefetcher (Available when supported by the CPU)

If set to Enabled, the hardware prefetcher will prefetch streams of data and instructions from the main memory to the L2 cache in the forward or backward manner to improve CPU performance. The options are **Disabled** and **Enabled**.

Adjacent Cache Line Prefetch (Available when supported by the CPU)

The CPU fetches the cache line for 64 bytes if this option is set to **Disabled**. The CPU fetches both cache lines for 128 bytes as comprised if **Enabled**.

Intel <R> Virtualization Technology (Available when supported by the CPU)

Select Enabled to use the feature of Virtualization Technology to allow one platform to run multiple operating systems and applications in independent partitions, creating multiple "virtual" systems in one physical computer. The options are **Enabled** and **Disabled**. **Note:** If there is any change to this setting, you will need to power off and restart the system for the change to take effect. Please refer to Intel's web site for detailed information.

Execute-Disable Bit Compatibly (Available when supported by the OS and the CPU)

Set to Enabled to enable the Execute Disable Bit which will allow the processor to designate areas in the system memory where an application code can execute and where it cannot, thus preventing a worm or a virus from flooding illegal codes to overwhelm the processor or damage the system during an attack. The default is **Enabled**. (Refer to Intel and Microsoft Web Sites for more information.)

Simultaneous Multi-Threading (Available when supported by the CPU)

Set to Enabled to use the Hyper-Threading Technology, which will result in increased CPU performance. The options are **Disabled** and **Enabled**.

Active Processor Cores

Set to Enabled to use a processor's Second Core and beyond. (Please refer to Intel's web site for more information.) The options are **All**, **1** and **2**.

Intel® EIST Technology

EIST (Enhanced Intel SpeedStep Technology) allows the system to automatically adjust processor voltage and core frequency in an effort to reduce power consump-

tion and heat dissipation. **Please refer to Intel's web site for detailed information.** The options are **Disable: Disable GV3** and **Enable: Enable GV3**.

Intel® TurboMode Tech (Available if Intel® EIST technology is Enabled)

This feature allows processor cores to run faster than marked frequency in specific conditions. The options are **Disabled** and **Enabled**.

Intel Turbo Boost Configuration

Turbo Ratio Limit Program

This enables a feature that sets a limit to how high the Processor's clock ratio is set in relation to the bus speed. The options are **Enabled** and **Disabled**

1 - Core Ratio Limit

This increases (multiplies) the Processor's core (1) clock speed in relation to the bus speed. Default is **26**. Press "+" or "-" on your keyboard to change this value.

2 ~ 3 - Core Ratio Limit

This increases the Processor's core (2~3) clock speed in relation to the bus speed. Default is **25**. Press "+" or "-" on your keyboard to change this value.

TDC Limit Override

This option will override the system's default Current settings for the processor. The options are **Enabled** and **Disabled**.

TDC Limit Value

This option sets the processor's Current value. The Default is **880**. Press "+" or "-" on your keyboard to change this value.

TDP Limit Override

This option will override the system's default Power settings for the processor. The options are **Enabled** and **Disabled**.

TDP Limit Value

This option sets the processor's Power value. Default is **1040**. Press "+" or "-" on your keyboard to change this value.

Intel® C-STATE Architecture



C-State Architecture is a type of processor power management developed by Intel to allow deeper power reduction from the basic C1 (Halt State) which blocks clock cycles to the CPU. C-State is an idle state and instructions are not processed by the CPU. A brief explanation of all the C-States are as follows:

C0 - Active. The CPU is processing instructions.

C1 - Auto Halt. The core clock (CPU) is off. This is the most basic idle state. Some CPUs support C1E (C1 Enhanced) for lower power consumption.

C2 - Stop Clock. Both the core clock (CPU) and bus clocks (I/O) are off.

C3 - Deep Sleep. The clock generator is off.

C4 - Deeper Deep Sleep. Reduced VCC (Voltage supply).

C6 - Cache Power Off. Power is turned off to all caches.

C7 - Processor Specific. Leaves initialized Application Processor in a processor-specific low C-State. For Intel® Core i7™ processors, this is the lowest supported C-State.

C1E Support

This should be enabled in order to use the "Enhanced Halt State" feature. C1E significantly reduces the CPU's power consumption by reducing the CPU's clock cycle and voltage during a "Halt State". The options are Disabled and **Enabled**.

C-STATE Tech

If enabled, C-State is set by the system automatically to either C2/C3/C4. The options are Disabled and **Enabled**.

C-State package limit setting

The selected option will be programmed into the C-State package limit register. The options are **Auto**, C1, C3, C6 and C7.

C1 Auto Demotion

When enabled, the CPU will conditionally demote C3/C6/C7 requests to C1 based on uncore auto-demote information. The options are Disabled and **Enabled**.

C3 Auto Demotion

When enabled, the CPU will conditionally demote C6/C7 requests to C1 based on uncore auto-demote information. Available options are Disabled and **Enabled**.

DCA

This feature cooperates with Intel I/O AT (Acceleration Technology) to accelerate the performance of TOE devices. (Note: A TOE device is a specialized, dedicated processor that is installed on an add-on card or a network card to handle some or all packet processing of this add-on card. For this motherboard, the TOE device is built inside the ESB 2 South Bridge chip.) The options are **Enabled** and Disabled.

DCA Prefetch Delay

A DCA Prefetch is used with TOE components to prefetch data in order to shorten execution cycles and maximize data processing efficiency. Prefetching too frequently can saturate the cache directory and delay necessary cache accesses. This feature reduces or increases the frequency the system prefetches data. The options are [8], [16], **[32]**, [40], [48], [56], [64], [72], [80], [88], [96], [104], [112], [120]

► Advanced Chipset Control

The items included in the Advanced Settings submenu are listed below:

QPI and IMC Configuration

QPI (QuickPath Interconnect) is the connection between the CPU and the motherboard's I/O hub. This section enables this feature to be modified according to the desired configuration, such as speed and power consumption.

QPI Links Speed

This feature selects QPI's data transfer speed.. The options are Slow-mode, and **Full Speed**

QPI Frequency

This selects the desired QPI frequency. The options are **Auto**, 4.800 GT, 6.400 GT.

QPI L0s and L1

This enables the QPI power state to low power. L0s and L1 are automatically selected by the motherboard. The options are **Disabled** and Enabled.

Memory Frequency

This feature forces a DDR3 frequency slower than what the system has detected. The available options are **Auto**, Force DDR-800, Force DDR-1066, Force DDR-1333, Force DDR-1600.

Memory Mode

The options are **Independent**, Channel Mirror, Lockstep and Sparing.

Independent - All DIMMs are available to the operating system.

Channel Mirror - The motherboard maintains two identical copies of all data in memory for redundancy.

Lockstep - The motherboard uses two areas of memory to run the same set of operations in parallel.

Sparing - A preset threshold of correctable errors is used to trigger fail-over. The spare memory is put online and used as active memory in place of the failed memory.

Demand Scrubbing

A memory error-correction scheme where the Processor writes corrected data back into the memory block from where it was read by the Processor. The options are **Disabled** and Enabled.

Patrol Scrubbing

A memory error-correction scheme that works in the background looking for and correcting resident errors. The options are **Disabled** and Enabled.

Throttling - Closed Loop

Throttling improves reliability and reduces power in the processor by automatic voltage control during processor idle states. Available options are **Disabled** and Enabled. If Enabled, the following items will appear:

Hyster Temp

Temperature Hysteresis is the temperature lag (in degrees Celsius) after the set DIMM temperature threshold is reached before Closed Loop Throttling begins. The options are **Disabled**, 1.5°C, 3.0°C, and 6.0°C.

Guardband Temp

This is the temperature which applies to the DIMM temperature threshold. Each step is in 0.5°C unit. The default is **[006]**. Press "+" or "-" on your keyboard to change this value.

Inlet Temp

This is the temperature detected at the chassis inlet. Each step is in 0.5°C unit. The default is **[070]**. Press "+" or "-" on your keyboard to change this value.

Temp Rise

This is the temperature rise to the DIMM thermal zone. Each step is in 0.5°C unit. The default is **[020]**. Press "+" or "-" on your keyboard to change this value.

Air Flow

This is the air flow speed to the DIMM modules. Each step is in mm/sec. The default is **[1500]**. Press "+" or "-" on your keyboard to change this value.

Altitude

This feature defines how many meters above or below sea level the system is located. Each step is in meters. The options are **Sea Level or Below**, 1~300, 301~600, 601~900, 901~1200, 1201~1500, 1501~1800, 1801~2100, 2101~2400, 2401~2700, 2701~3000.

DIMM Pitch

This is the physical space between each DIMM module. Each step is in 1/1000 of an inch. The default is **[400]**. Press "+" or "-" on your keyboard to change this value.

Throttling - Open Loop

If Enabled, the same options as in **Throttling - Closed Loop** above will appear with the exception of Hyster Temp and Guardband Temp. The options are **Disabled** and Enabled.

High Performance Event Timer

Select Enabled to activate the High Performance Event Timer (HPET) that produces periodic interrupts at a much higher frequency than a Real-time Clock (RTC) does in synchronizing multimedia streams, providing smooth playback and reducing the dependency on other timestamp calculation devices, such as an x86 RDTSC Instruction embedded in the CPU. The High Performance Event Timer is used to replace the 8254 Programmable Interval Timer. The options are Enabled and **Disabled**.

HDA Controller

Select Enabled to enable the High-Definition Audio Controller. The options are **Enabled** and Disabled.

Intel VT-d

Select Enabled to enable Intel's Virtualization Technology support for Direct I/O VT-d by reporting the I/O device assignments to VMM through the DMAR ACPI Tables. This feature offers fully-protected I/O resource-sharing across the Intel platforms, providing the user with greater reliability, security and availability in networking and data-sharing. The settings are Enabled and **Disabled**.

Intel I/OAT

The Intel I/OAT (I/O Acceleration Technology) significantly reduces CPU overhead by leveraging CPU architectural improvements, freeing resources for more other tasks. Available options are Disabled and **Enabled**.

Active State Power Management

Select Enabled to start Active-State Power Management for signal transactions between L0 and L1 Links on the PCI Express Bus. This maximizes power-saving and transaction speed. The options are Enabled and **Disabled**.

USB Functions

This feature allows the user to decide the number of onboard USB ports to be enabled. The Options are: Disabled, 2 USB ports, 4 USB ports, 6 USB ports, 8 USB ports, 10 USB ports and **12 USB ports**.

USB2.0 Controller

Select Enabled to activate the onboard USB2.0 controller. The options are **Enabled** and Disabled.

Legacy USB Support

Select Enabled to use Legacy USB devices. If this item is set to Auto, Legacy USB support will be automatically enabled if a legacy USB device is installed on the motherboard, and vice versa. The settings are Disabled, Enabled and **Auto**.

► IDE / Floppy Configuration

When this submenu is selected, the AMI BIOS automatically detects the presence of the IDE Devices and displays the following items:

Floppy A

This feature allows the user to select the type of floppy drive connected to the system. The options are Disabled, 360KB 5 1/4", 1.2MB 5 1/4", 720KB 3 1/2", **1.44MB 3 1/2"** and 2.88MB 3 1/2".

SATA#1 Configuration

If Compatible is selected, it sets SATA#1 to legacy compatibility mode, while selecting Enhanced sets SATA#1 to native SATA mode. The options are Disabled, Compatible, **Enhanced**

Configure SATA#1 As

This feature allows the user to select the drive type for SATA#1. The options are **IDE**, RAID and AHCI.

ICH RAID CodeBase (Available if RAID is selected above)

Select Intel to enable the Intel SATA Host RAID Utility. Select Intel to use the **Intel** HostRAID Utility. The options are **Intel** and Adaptec.

Max Ports on SATA#1 (Available if either RAID or AHCI is enabled under "Configure SATA#1 as" above)

The options are 4 Ports and **6 Ports**.

SATA#2 Configuration

Selecting Enhanced will set SATA#2 to native SATA mode. The options are Disabled, **Enhanced**

IDE Detect Timeout (sec)

Use this feature to set the time-out value for the BIOS to detect the ATA, ATAPI devices installed in the system. The options are 0 (sec), 5, 10, 15, 20, 25, 30, and **35**.

AHCI CD/DVD Boot Timeout

Use this feature to set the time-out value for the BIOS to detect the AHCI CD/DVD boot devices installed in the system. The options are 0 (sec), 5, 10, 15, 20, 25, 30, and **35**.

Primary IDE Master/Slave, Secondary IDE Master/Slave, Third IDE Master, and fourth IDE Master

These settings allow the user to set the parameters of Primary IDE Master/Slave, Secondary IDE Master/Slave, Third and Fourth IDE Master slots. Hit <Enter> to activate the following submenu screen for detailed options of these items. Set the correct configurations accordingly. The items included in the submenu are:

Type

Select the type of device connected to the system. The options are Not Installed, **Auto**, CD/DVD and ARMD.

LBA/Large Mode

LBA (Logical Block Addressing) is a method of addressing data on a disk drive. In the LBA mode, the maximum drive capacity is 137 GB. For drive capacities over 137 GB, your system must be equipped with a 48-bit LBA mode addressing. If not, contact your manufacturer or install an ATA/133 IDE controller card that supports 48-bit LBA mode. The options are Disabled and **Auto**.

Block (Multi-Sector Transfer)

Block Mode boosts the IDE drive performance by increasing the amount of data transferred. Only 512 bytes of data can be transferred per interrupt if Block Mode is not used. Block Mode allows transfers of up to 64 KB per interrupt. Select Disabled to allow data to be transferred from and to the device one sector at a time. Select Auto to allow data transfer from and to the device occur multiple sectors at a time if the device supports it. The options are **Auto** and Disabled.

PIO Mode

The IDE PIO (Programmable I/O) Mode programs timing cycles between the IDE drive and the programmable IDE controller. As the PIO mode increases, the cycle time decreases. The options are **Auto**, 0, 1, 2, 3, and 4. Select Auto to allow the AMI BIOS to automatically detect the PIO mode. Use this value if the IDE disk drive support cannot be determined. Select 0 to allow the AMI BIOS to use PIO mode 0. It has a data transfer rate of 3.3 MBs. Select 1 to allow the AMI BIOS to use PIO mode 1. It has a data transfer rate of 5.2 MBs. Select 2 to allow the AMI BIOS to use PIO mode 2. It has a data transfer rate of 8.3 MBs. Select 3 to allow the AMI BIOS to use PIO mode 3. It has a data transfer rate of 11.1 MBs. Select 4 to allow the AMI BIOS to use PIO mode 4. It has a data transfer 32-Bit Data Transfer. Select Enabled to enable 32-Bit data transfer.

DMA Mode

Select Auto to allow the BIOS to automatically detect IDE DMA mode when the IDE disk drive support cannot be determined. Select SWDMA0 to allow the BIOS

to use Single Word DMA mode 0. It has a data transfer rate of 2.1 MBs. Select SWDMA1 to allow the BIOS to use Single Word DMA mode 1. It has a data transfer rate of 4.2 MBs. Select SWDMA2 to allow the BIOS to use Single Word DMA mode 2. It has a data transfer rate of 8.3 MBs. Select MWDMA0 to allow the BIOS to use Multi Word DMA mode 0. It has a data transfer rate of 4.2 MBs. Select MWDMA1 to allow the BIOS to use Multi Word DMA mode 1. It has a data transfer rate of 13.3 MBs. Select MWDMA2 to allow the BIOS to use Multi-Word DMA mode 2. It has a data transfer rate of 16.6 MBs. Select UDMA0 to allow the BIOS to use Ultra DMA mode 0. It has a data transfer rate of 16.6 MBs. It has the same transfer rate as PIO mode 4 and Multi Word DMA mode 2. Select UDMA1 to allow the BIOS to use Ultra DMA mode 1. It has a data transfer rate of 25 MBs. Select UDMA2 to allow the BIOS to use Ultra DMA mode 2. It has a data transfer rate of 33.3 MBs. Select UDMA3 to allow the BIOS to use Ultra DMA mode 3. It has a data transfer rate of 66.6 MBs. Select UDMA4 to allow the BIOS to use Ultra DMA mode 4 . It has a data transfer rate of 100 MBs. The options are **Auto**, SWDMA_n, MWDMA_n, and UDMA_n.

S.M.A.R.T. For Hard disk drives

Self-Monitoring Analysis and Reporting Technology (SMART) can help predict impending drive failures. Select Auto to allow the AMI BIOS to automatically detect hard disk drive support. Select Disabled to prevent the AMI BIOS from using the S.M.A.R.T. Select Enabled to allow the AMI BIOS to use the S.M.A.R.T. to support hard drive disk. The options are Disabled, Enabled, and **Auto**.

32Bit Data Transfer

Select Enable to enable the function of 32-bit IDE data transfer. The options are Enabled and **Disabled**. (**Note:** The default setting changes when different devices are installed.)

► PCI/PnP Configuration

This feature allows the user to set the PCI/PnP configurations for the following items:

Clear NVRAM

This feature clears the NVRAM during system boot. The options are **No** and Yes.

Plug & Play OS

Selecting Yes allows the OS to configure Plug & Play devices. (This is not required for system boot if your system has an OS that supports Plug & Play.) Select **No** to allow the AMI BIOS to configure all devices in the system.

PCI Latency Timer

This feature sets the latency Timer of each PCI device installed on a PCI bus. Select 64 to set the PCI latency to 64 PCI clock cycles. The options are 32, **64**, 96, 128, 160, 192, 224 and 248.

PCIX Slot Frequency

Use this setting to change the clock frequency of the PCIX slot(s). The available options are **Auto**, 33MHz PCI, 66MHz PCI, 66MHz PCI-X M1, 100MHz PCI-X M1, and 133MHz PCI-X M1.

PXH IOAPIC Function

Disable this setting for Windows Vista and Windows 2008. This is provided to optimize compatibility. The options are **Disabled** and Enabled.

PCI IDE Bus Master

When enabled, the BIOS uses PCI bus mastering for reading/writing to IDE drives. The options are Disabled and **Enabled**.

PCI Slot 1 ~ PCI Slot 6

Use this setting to disable any of the PCI slots. The options are Disabled and **Enabled**.

Load Onboard LAN1 Option ROM, Load Onboard LAN2 Option ROM

This feature is to enable LAN OPROM for PXE. This is to boot computers using a network interface. The options are **Disabled** and Enabled.

► Super IO Device Configuration

Serial Port1 Address/ Serial Port2 Address

This option specifies the base I/O port address and the Interrupt Request address of Serial Port 1 and Serial Port 2. Select Disabled to prevent the serial port from accessing any system resources. When this option is set to Disabled, the serial port physically becomes unavailable. Select 3F8/IRQ4 to allow the serial port to use 3F8 as its I/O port address and IRQ 4 for the interrupt address. The options for Serial Port1 are Disabled, **3F8/IRQ4**, 3E8/IRQ4, 2E8/IRQ3. The options for Serial Port2 are Disabled, **2F8/IRQ3**, 3E8/IRQ4, and 2E8/IRQ3.

Serial Port 2 Mode

Use this feature to configure Serial Port 2 mode. The options are **Normal**, IrDA and ASK IR. IrDA (Infra-Red Data) is an industry standard for remote control

devices. ASK IR (Amplitude Shifted Keying Infra-Red) is a protocol compatible with Sharp® branded PDAs and other infra-red devices.

Floppy Controller

Select Enabled to enable the onboard Floppy Controller. The options are **Enabled** and Disabled.

► Remote Access Configuration

Remote Access

This feature allows the user to enable the function of Remote Access. The options are **Disabled** and Enabled.

If the item Remote Access is set to Enabled, the following items will display:

Serial Port Number

This feature allows the user decide which serial port to be used for Console Redirection. The options are **COM 1**, and COM 2.

Serial Port Mode

This feature allows the user to set the serial port mode for Console Redirection. The options are **115200 8, n 1**; 57600 8, n, 1; 38400 8, n, 1; 19200 8, n, 1; and 9600 8, n, 1.

Flow Control

This feature allows the user to set the flow control for Console Redirection. The options are **None**, Hardware, and Software.

Redirection After BIOS POST

Select Disabled to turn off Console Redirection after Power_On_Self_Test (POST). Select Always to keep Console Redirection active all the time after POST. (Note: This setting may not be supported by some operating systems.) Select Boot Loader to keep Console Redirection active during POST and Boot Loader. The options are Disabled, Boot Loader, and **Always**.

Terminal Type

This feature allows the user to select the target terminal type for Console Redirection. The options are ANSI, **VT100**, and VT-UTF8.

VT-UTF8 Combo Key Support

A terminal keyboard definition that provides a way to send commands from a remote console. Available options are **Enabled** and Disabled.

Sredir Memory Display Delay

This feature defines the length of time in seconds to display memory information. The options are **No Delay**, Delay 1 Sec, Delay 2 Sec, and Delay 4 Sec.

► Hardware Health Configuration

This feature allows the user to monitor Hardware Health of the system and review the status of each item when displayed.

CPU Temperature, System Temperature

CPU Temperature Threshold

This option allows the user to set the CPU Overheat Temperature Threshold. When the CPU temperature reaches this overheat threshold, the system will slow down and the CPU fan will be activated to prevent CPU overheat. The options are TControl (the Thermal Control Setting inside the CPU), **TControl + 5°** (Thermal Control Setting + 5°C), and TControl + 10° (Thermal Control Setting + 10°C).

Fan Speed Control Modes

This feature allows the user to decide how the system controls the speeds of the onboard fans. The CPU temperature and the fan speed are correlative. When the CPU on-die temperature increases, the fan speed will also increase, and vice versa. Select Workstation if your system is used as a Workstation. Select Server if your system is used as a Server. Select “Disabled, (Full Speed @12V)” to disable the fan speed control function and allow the onboard fans to constantly run at the full speed (12V). The Options are: 1. **Disabled**, 2. 4-pin (Super Quiet), and 3. 4-pin (Workstation).

Voltage Monitoring

Vcore, +3.3Vcc, 12V, V_DIMM, 5V, -12V, 3.3VSB, and Vbatt.

Note: In the Windows OS environment, the Supero Doctor III settings take precedence over the BIOS settings. When first installed, Supero Doctor III adopts the temperature threshold settings previously set in the BIOS. Any subsequent changes to these thresholds must be made within Supero Doctor, since the SD III settings override the BIOS settings. For the Windows OS to adopt the BIOS temperature threshold settings, please change the SDIII settings to be the same as those set in the BIOS.



► ACPI Configuration

Use this feature to configure ACPI (Advanced Configuration and Power Interface) power management settings for your system.

USB Device Wake-Up

This feature is used to awaken from Standby mode by a universal serial bus (USB) device (such as, a USB mouse or USB keyboard). The options are Enabled and **Disabled**.

PS2 KB/MS Wake-Up

This feature is used to awaken from Standby mode by a PS/2 mouse or PS/2 keyboard. The options are Enabled and **Disabled**.

ACPI Aware O/S

Enable ACPI support if it is supported by the OS to control ACPI through the Operating System. Otherwise, disable this feature. The options are **Yes** and No.

Suspend Mode

This option is used to select the ACPI State that is used for system suspend. The options are **S1 (POS)**, S3 (STR) and Auto.

S1 (POS) - All processor caches are erased, and stops executing instructions. Power to the CPU(s) and RAM is maintained, but RAM is refreshed.

S3 (STR) - The CPU has no power and the power supply goes on reduced power mode. However, main memory (RAM) is still powered.

Headless Mode

This feature is used to enable system to function without a keyboard, monitor or mouse attached. The options are Enabled and **Disabled**.

ACPI Version Features

The options are ACPI v1.0, **ACPI v2.0** and ACPI v3.0. Please refer to ACPI's website for further explanation: <http://www.acpi.info/>

► Event Log Configuration

View Event Log

Use this option to view the System Event Log.

Mark all events as read

This option marks all events as read. The options are OK and **Cancel**.

Clear event log

This option clears the Event Log memory of all messages. The options are OK and **Cancel**.

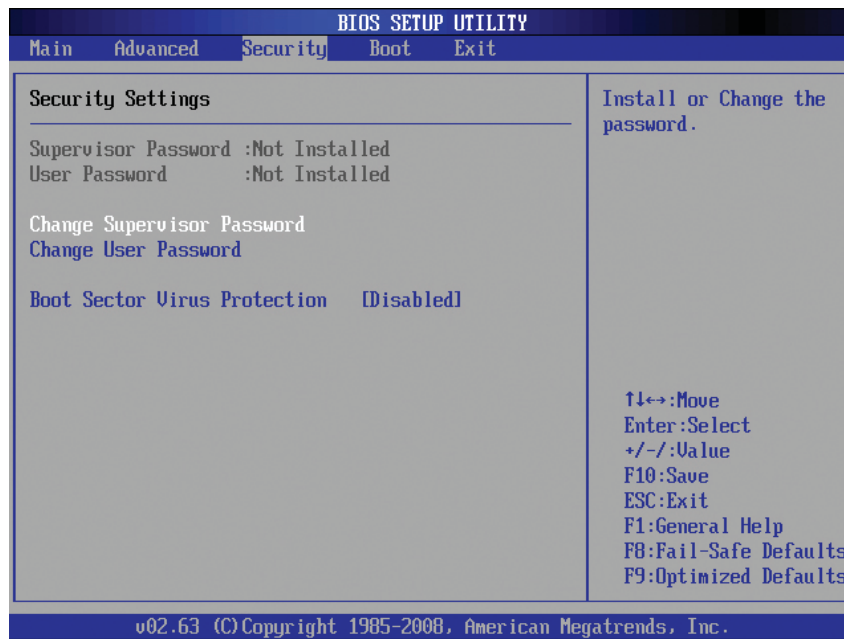
**7-4 Security Settings**

The AMI BIOS provides a Supervisor and a User password. If you use both passwords, the Supervisor password must be set first.

Supervisor Password

This item indicates if a supervisor password has been entered for the system. Clear means such a password has not been used and Set means a supervisor password has been entered for the system.

User Password Is:

This item indicates if a user password has been entered for the system. Clear means such a password has not been used and Set means a user password has been entered for the system.

Change Supervisor Password

Select this feature and press <Enter> to access the submenu, and then type in a new Supervisor Password.

User Access Level (Available when Supervisor Password is set as above)

Available options are **Full Access**: grants full User read and write access to the Setup Utility, **View Only**: allows access to the Setup Utility but the fields cannot be changed, **Limited**: allows only limited fields to be changed such as Date and Time, **No Access**: prevents User access to the Setup Utility.

Change User Password

Select this feature and press <Enter> to access the submenu , and then type in a new User Password.

Clear User Password (Available only if User Password has been set)

Password Check

Available options are **Setup** and Always.

Boot Sector Virus Protection

When Enabled, the AMI BOIS displays a warning when any program (or virus) issues a Disk Format command or attempts to write to the boot sector of the hard disk drive. The options are Enabled and **Disabled**.

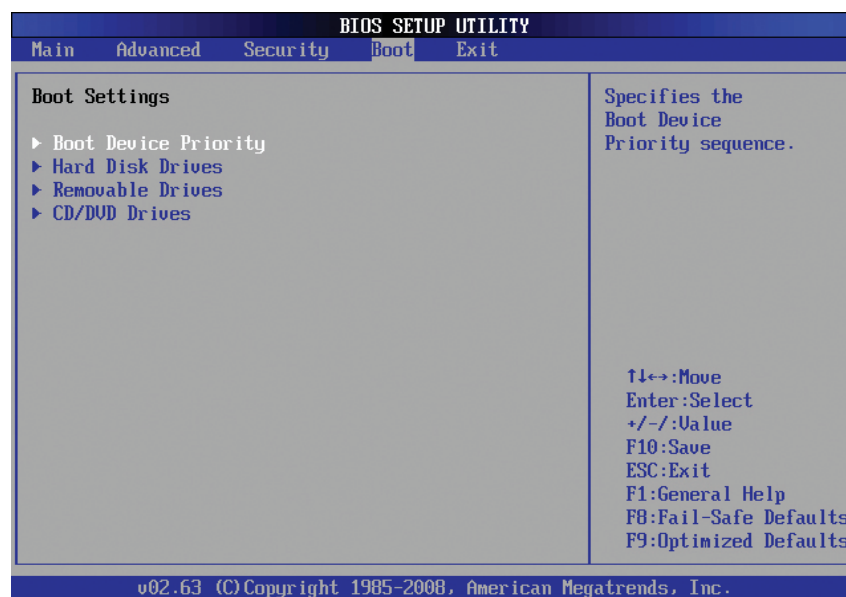

7-5 Boot Configuration

Use this feature to configure Boot Settings:

▶ Boot Device Priority

This feature allows the user to specify the sequence of priority for the Boot Device. The settings are 1st boot device, 2nd boot device, 3rd boot device, and Disabled.

- 1st boot device - 1st Floppy Drive
- 2nd boot device - [CD/DVD: XXXXXXXXXXXX]
- 3rd boot device - [SATA: XXXXXXXXXXXX]

► Removable Drives

This feature allows the user to specify the boot sequence from available Removable Drives. The settings are 1st boot device, 2nd boot device, and Disabled.

- 1st Drive
- 2nd boot device - [USB: XXXXXXXXXX]

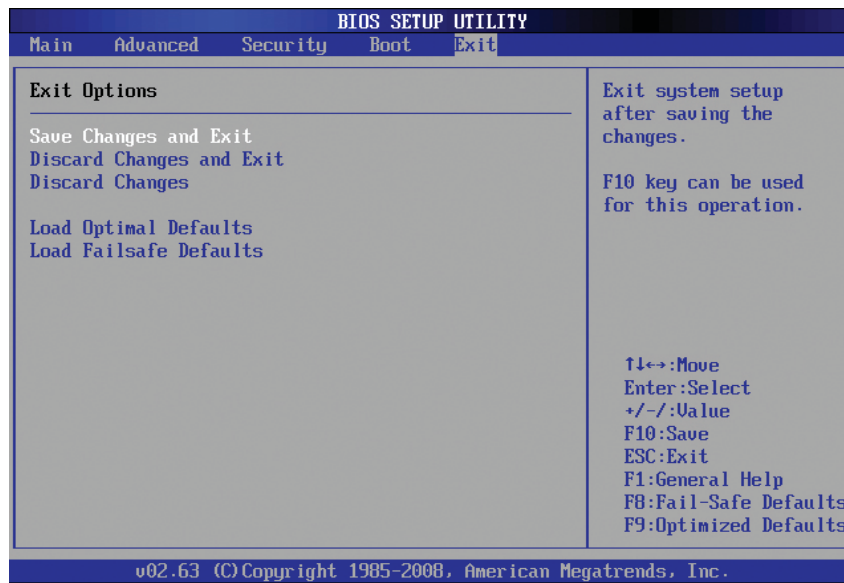

7-6 Exit Options

Select the Exit tab from the AMI BIOS Setup Utility screen to enter the Exit BIOS Setup screen.

Save Changes and Exit

When you have completed the system configuration changes, select this option to leave the BIOS Setup Utility and reboot the computer, so the new system configuration parameters can take effect. Select Save Changes and Exit from the Exit menu and press <Enter>.

Discard Changes and Exit

Select this option to quit the BIOS Setup without making any permanent changes to the system configuration, and reboot the computer. Select Discard Changes and Exit from the Exit menu and press <Enter>.

Discard Changes

Select this option and press <Enter> to discard all the changes and return to the AMI BIOS Utility Program.

Load Optimal Defaults

To set this feature, select Load Optimal Defaults from the Exit menu and press <Enter>. Then, select OK to allow the AMI BIOS to automatically load Optimal Defaults to the BIOS Settings. The Optimal settings are designed for maximum system performance, but may not work best for all computer applications.

Load Fail-Safe Defaults

To set this feature, select Load Fail-Safe Defaults from the Exit menu and press <Enter>. The Fail-Safe settings are designed for maximum system stability, but not for maximum performance.

Notes

Appendix A

POST Error Beep Codes

This section lists POST (Power On Self Test) error beep codes for the Phoenix BIOS. POST error beep codes are divided into two categories: recoverable and terminal. This section lists Beep Codes for recoverable POST errors.

Recoverable POST Error Beep Codes

When a recoverable type of error occurs during POST, BIOS will display a POST code that describes the problem. BIOS may also issue one of the following beep codes:

- 1 long and two short beeps - video configuration error
- 1 repetitive long beep - no memory detected
- 1 continuous beep with the front panel Overheat LED on - system overheat

Notes

Appendix B

Software Installation Instructions

B-1 Installing Drivers

After you've installed the Windows Operating System, a screen as shown below will appear. You are ready to install software programs and drivers that have not yet been installed. To install these software programs and drivers, click the icons to the right of these items.

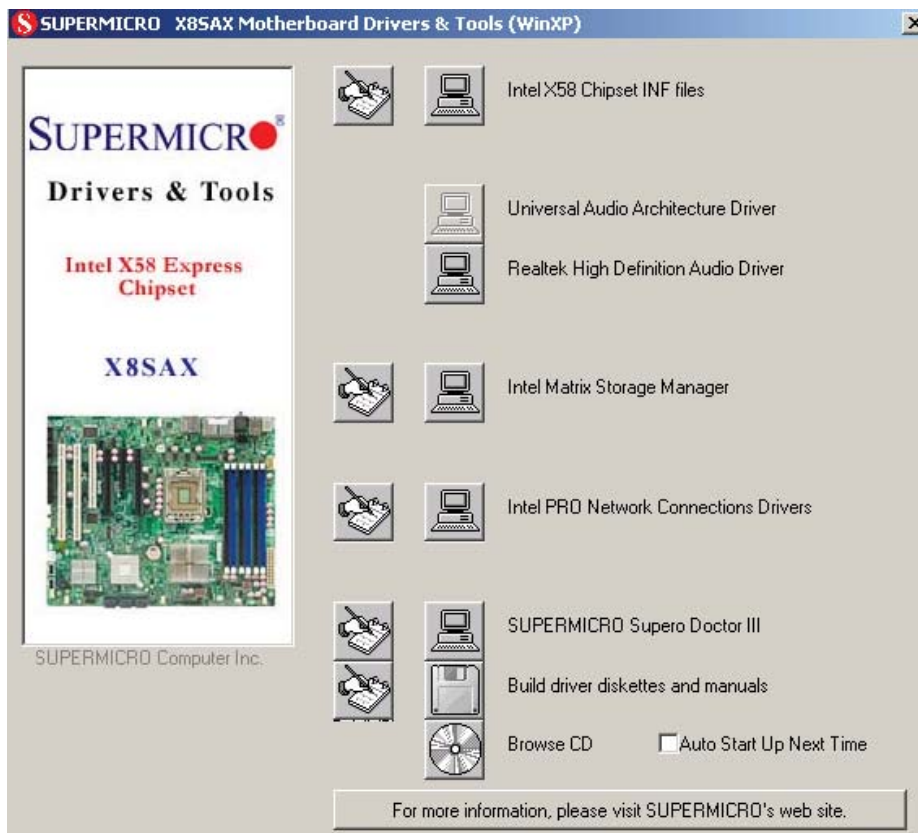

Driver/Tool Installation Display Screen

Note: Click the icons showing a hand writing on the paper to view the readme files for each item. Click a computer icon to the right of an item (from top to the bottom) one at a time. After installing each item, you must re-boot the system before proceeding with the next item on the list. The bottom icon with a CD on it allows you to view the entire contents of the CD.

B-2 Configuring Supero Doctor III

The Supero Doctor III program is a Web-base management tool that supports remote management capability. It includes Remote and Local Management tools. The local management is called the SD III Client. The Supero Doctor III program included on the CDROM that came with your motherboard allows you to monitor the environment and operations of your system. Supero Doctor III displays crucial system information such as CPU temperature, system voltages and fan status. See the Figure below for a display of the Supero Doctor III interface.

Note 1: Both default user name and password are ADMIN.

Note 2: In the Windows OS environment, the Supero Doctor III settings take precedence over the BIOS settings. When first installed, Supero Doctor III adopts the temperature threshold settings previously set in the BIOS. Any subsequent changes to these thresholds must be made within Supero Doctor, since the SD III settings override the BIOS settings. For the Windows OS to adopt the BIOS temperature threshold settings, please change the SDIII settings to be the same as those set in the BIOS.

Supero Doctor III Interface Display Screen-I (Health Information)

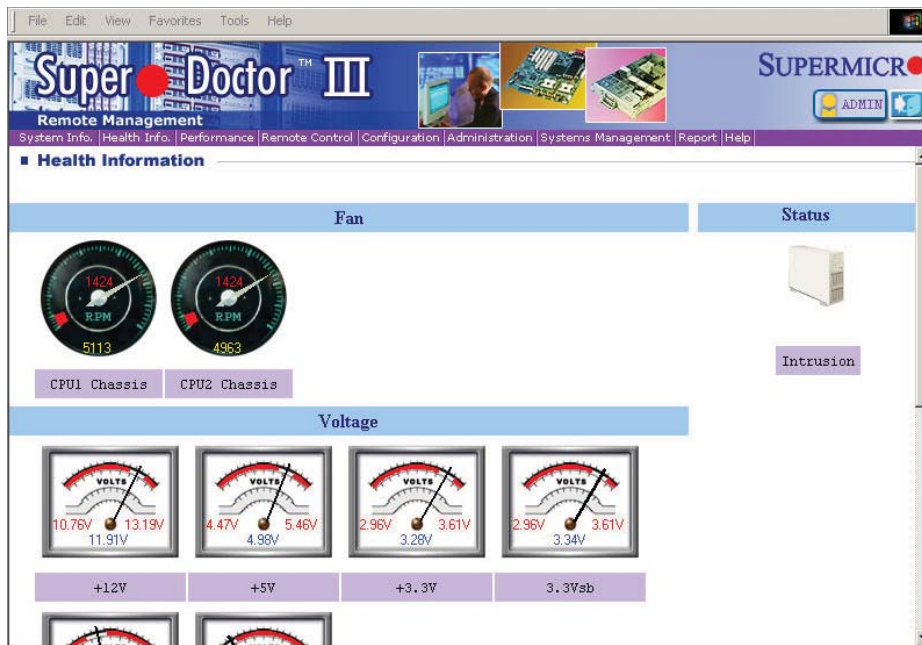

Supero Doctor III Interface Display Screen-II (Remote Control)



Note: SD III Software Revision 1.0 can be downloaded from our Web site at: ftp://ftp.supermicro.com/utility/Supero_Doctor_III/. You can also download SDIII User's Guide at: <http://www.supermicro.com/PRODUCT/Manuals/SDIII/UserGuide.pdf>. For Linux, we will still recommend that you use Supero Doctor II.

Notes

Appendix C

System Specifications

Processors

One Intel Core™ i7, i7 Extreme Edition or future Intel Nehalem processor families (next generation Intel Xeon® processor)

Note: Please refer to our web site for a complete listing of supported processors.

Chipset

Intel X58 + ICH10R

BIOS

16 Mb Phoenix® BIOS

Memory Capacity

Six DIMM sockets supporting up to 24 GB of unbuffered, ECC/non-ECC DDR3-1600/1333/1066/800 SDRAM

Note: See the memory section in Chapter 5 for details.

SATA Controller

Intel on-chip controller for 3 Gb/s Serial ATA (RAID 0, 1, 5 and 10 supported)

Drive Bays

Eight (8) hot-swap drive bays to house eight SAS or six SATA drives

Peripheral Drive Bays

Two (2) 5.25" drive bays

Expansion Slots

Supports the use of six standard size PCI add-on cards: two PXI-E 2.0 x16 slots, one PCI-E x4 (in a x8 slot) and one PCI slot.

Serverboard

C7X58 (proprietary ATX form factor)

Dimensions: 12" x 10" (305 x 254 mm)

Chassis

SC743TQ-865-SQ Form Factor: tower/4U rackmount

Dimensions (as tower): (WxHxD) 7 x 17.2 x 25.5 in. (178 x 437 x 648 mm)

Weight

Gross (Bare Bone): 64 lbs. (29.1 kg.)

System Cooling

Two (2) 8-cm low-noise chassis fans

One (1) 9-cm low-noise exhaust fan

System Input Requirements

AC Input Voltage: 100-240V AC auto-range

Rated Input Current: 100 (12A) - 240V (6A)

Rated Input Frequency: 50 to 60 Hz

PFC Power Supply

Rated Output Power: 865W (Part# PWS-865-PQ)

Rated Output Voltages: +3.3V (30A), +5V (30A), +12V_{ALL} (70A), +5Vsb (6.5A)

Operating Environment

Operating Temperature: 10° to 35° C (50° to 95° F)

Non-operating Temperature: -40° to 70° C (-40° to 158° F)

Operating Relative Humidity: 8% to 90% (non-condensing)

Non-operating Relative Humidity: 5 to 95% (non-condensing)

Regulatory Compliance

Electromagnetic Emissions: FCC Class B, EN 55022 Class B, EN 61000-3-2/-3-3, CISPR 22 Class B

Electromagnetic Immunity: EN 55024/CISPR 24, (EN 61000-4-2, EN 61000-4-3, EN 61000-4-4, EN 61000-4-5, EN 61000-4-6, EN 61000-4-8, EN 61000-4-11)

Safety: CSA/EN/IEC/UL 60950-1 Compliant, UL or CSA Listed (USA and Canada), CE Marking (Europe)

California Best Management Practices Regulations for Perchlorate Materials:

This Perchlorate warning applies only to products containing CR (Manganese Dioxide) Lithium coin cells. "Perchlorate Material-special handling may apply. See www.dtsc.ca.gov/hazardouswaste/perchlorate"

Notes

(continued from front)

The products sold by Supermicro are not intended for and will not be used in life support systems, medical equipment, nuclear facilities or systems, aircraft, aircraft devices, aircraft/emergency communication devices or other critical systems whose failure to perform be reasonably expected to result in significant injury or loss of life or catastrophic property damage. Accordingly, Supermicro disclaims any and all liability, and should buyer use or sell such products for use in such ultra-hazardous applications, it does so entirely at its own risk. Furthermore, buyer agrees to fully indemnify, defend and hold Supermicro harmless for and against any and all claims, demands, actions, litigation, and proceedings of any kind arising out of or related to such ultra-hazardous use or sale.