

# AS 4040C-TR AS 4040C-8R

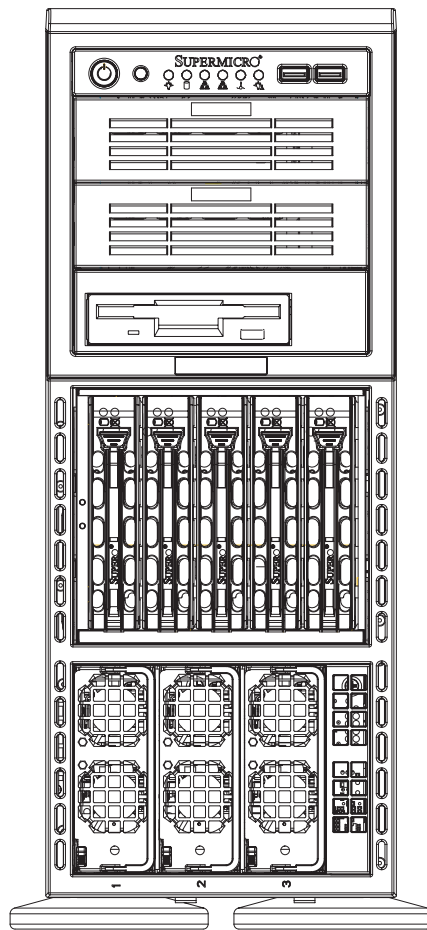

## USER'S MANUAL

---

The information in this User's Manual has been carefully reviewed and is believed to be accurate. The vendor assumes no responsibility for any inaccuracies that may be contained in this document, makes no commitment to update or to keep current the information in this manual, or to notify any person or organization of the updates.

The manufacturer reserves the right to make changes to the product described in this manual at any time and without notice. This product, including software, if any, and documentation may not, in whole or in part, be copied, photocopied, reproduced, translated or reduced to any medium or machine without prior written consent.

IN NO EVENT WILL THE MANUFACTURER BE LIABLE FOR DIRECT, INDIRECT, SPECIAL, INCIDENTAL, OR CONSEQUENTIAL DAMAGES ARISING FROM THE USE OR INABILITY TO USE THIS PRODUCT OR DOCUMENTATION, EVEN IF ADVISED OF THE POSSIBILITY OF SUCH DAMAGES. IN PARTICULAR, THE VENDOR SHALL NOT HAVE LIABILITY FOR ANY HARDWARE, SOFTWARE, OR DATA STORED OR USED WITH THE PRODUCT, INCLUDING THE COSTS OF REPAIRING, REPLACING, INTEGRATING, INSTALLING OR RECOVERING SUCH HARDWARE, SOFTWARE, OR DATA.

Any disputes arising between manufacturer and customer shall be governed by the laws of Santa Clara County in the State of California, USA. The State of California, County of Santa Clara shall be the exclusive venue for the resolution of any such disputes. The manufacturer's total liability for all claims will not exceed the price paid for the hardware product.

---

Manual Revision 1.0

Release Date: October 19, 2006

Unless you request and receive written permission from the manufacturer, you may not copy any part of this document.

Information in this document is subject to change without notice. Other products and companies referred to herein are trademarks or registered trademarks of their respective companies or mark holders.

Copyright © 2006  
All rights reserved.

**Printed in the United States of America**

## Preface

### About This Manual

This manual is written for professional system integrators and PC technicians. It provides information for the installation and use of the AS4040C-TR/4040C-8R. Installation and maintenance should be performed by experienced technicians only.

The 4040C-TR/4040C-8R is a high-end tower based on the SC748TQ-R1000/SC748S-R1000 server chassis and the H8QCE/H8QC8 serverboard, which supports four AMD Opteron™ 800 series processors and up to 32 GB of ECC registered DDR400 or 64 GB of ECC registered DDR333/266 SDRAM memory.

### Manual Organization

#### Chapter 1: Introduction

The first chapter provides a checklist of the main components included with the server system and describes the main features of the H8QCE/H8QC8 serverboard and the SC748TQ-R1000/SC748S-R1000 chassis, which make up the 4040C-TR/4040C-8R.

#### Chapter 2: Server Installation

This chapter describes the steps necessary to install the 4040C-TR/4040C-8R into a rack and check out the server configuration prior to powering up the system. If your server was ordered without processor and memory components, this chapter will refer you to the appropriate sections of the manual for their installation.

#### Chapter 3: System Interface

Refer here for details on the system interface, which includes the functions and information provided by the control panel on the chassis as well as other LEDs located throughout the system.

## **Chapter 4: System Safety**

You should thoroughly familiarize yourself with this chapter for a general overview of safety precautions that should be followed when installing and servicing the 4040C-TR/4040C-8R.

## **Chapter 5: Advanced Serverboard Setup**

Chapter 5 provides detailed information on the H8QCE/H8QC8 serverboard, including the locations and functions of connectors, headers and jumpers. Refer to this chapter when adding or removing processors or main memory and when reconfiguring the serverboard.

## **Chapter 6: Advanced Chassis Setup**

Refer to Chapter 6 for detailed information on the SC748TQ-R1000/SC748S-R1000 1U rackmount server chassis. You should follow the procedures given in this chapter when installing, removing or reconfiguring SATA/SCSI or peripheral drives and when replacing the system power supply units and cooling fans.

## **Chapter 7: BIOS**

The BIOS chapter includes an introduction to BIOS and provides detailed information on running the CMOS Setup Utility.

## **Appendix A: BIOS Error Beep Codes**

## **Appendix B: BIOS POST Checkpoint Codes**

## **Appendix C: System Specifications**

## Notes

# Table of Contents

## Preface

About This Manual .....	iii
Manual Organization .....	iii

## Chapter 1: Introduction

1-1 Overview .....	1-1
1-2 Serverboard Features .....	1-2
1-3 Server Chassis Features .....	1-3

## Chapter 2: Server Installation

2-1 Overview .....	2-1
2-2 Unpacking the System .....	2-1
2-3 Preparing for Setup .....	2-1
Choosing a Setup Location .....	2-2
Rack Precautions .....	2-2
Server Precautions .....	2-2
Rack Mounting Considerations .....	2-3
2-4 Installing the System into a Rack .....	2-4
Identifying the Sections of the Rack Rails .....	2-4
Installing the Chassis Rails .....	2-5
Installing the Rack Rails.....	2-6
Installing the Server into the Rack.....	2-7
2-5 Checking the Serverboard Setup .....	2-8
2-6 Checking the Drive Bay Setup .....	2-9

## Chapter 3: System Interface

3-1 Overview .....	3-1
3-2 Control Panel Buttons .....	3-1
Reset .....	3-1
Power .....	3-1
3-3 Control Panel LEDs .....	3-2
Power Fail .....	3-2
Overheat/Fan Fail .....	3-2
NIC2 .....	3-2
NIC1 .....	3-2
HDD .....	3-3
Power .....	3-3

3-4	Drive Carrier LEDs .....	3-3
<b>Chapter 4: System Safety</b>		
4-1	Electrical Safety Precautions .....	4-1
4-2	General Safety Precautions .....	4-2
4-3	ESD Precautions .....	4-3
4-4	Operating Precautions .....	4-4
<b>Chapter 5: Advanced Serverboard Setup</b>		
5-1	Handling the Serverboard .....	5-1
5-2	Mounting the Serverboard into a Chassis .....	5-2
5-3	Processor and Heatsink Installation .....	5-3
5-4	Connecting Cables .....	5-5
	Connecting Data Cables .....	5-5
	Connecting Power Cables .....	5-5
	Connecting the Control Panel .....	5-5
5-5	I/O Ports .....	5-6
5-6	Installing Memory .....	5-7
5-7	Adding PCI Cards .....	5-8
5-8	Serverboard Details .....	5-9
	H8QC8/H8QCE Layout .....	5-9
	H8QC8/H8QCE Quick Reference .....	5-10
5-9	Connector Definitions .....	5-11
	ATX Power Connector .....	5-11
	Auxilliary 1 Power Connector .....	5-11
	Auxilliary 2 Power Connector .....	5-11
	Power LED .....	5-11
	HDD LED .....	5-12
	NIC1 LED .....	5-12
	NIC2 LED .....	5-12
	Overheat/Fan Fail LED .....	5-12
	Power Fail LED .....	5-13
	Reset Button .....	5-13
	Power Button .....	5-13
	Universal Serial Bus Ports .....	5-13
	USB Headers .....	5-14
	Serial Ports .....	5-14
	Fan Headers .....	5-14
	JLAN 1/2 (Ethernet Ports) .....	5-14
	Power LED/Keylock/Speaker .....	5-15

ATX PS/2 Keyboard & Mouse Ports .....	5-15
Chassis Intrusion .....	5-15
Wake-On-LAN .....	5-16
Wake-On-Ring .....	5-16
Overheat LED .....	5-16
3rd Power Supply Alarm Reset Header .....	5-16
I <sup>2</sup> C Header for Power Supply .....	5-17
SMBus Header .....	5-17
Additional Fan Headers .....	5-17
Compact Flash Power Headers .....	5-17
5-10 Jumper Settings.....	5-18
Explanation of Jumpers.....	5-18
CMOS Clear .....	5-18
SCSI Controller Enable/Disable .....	5-19
SCSI Termination Enable/Disable .....	5-19
3rd Power Supply Fail Signal Enable/Disable .....	5-19
Watch Dog Enable/Disable .....	5-20
JLAN Enable/Disable .....	5-20
VGA Enable/Disable.....	5-20
5-11 Onboard Indicators .....	5-21
JLAN1/JLAN2 LEDs .....	5-21
5-12 Floppy, IDE, Parallel Port, SCSI and SATA Drive Connections.....	5-22
Floppy Connector.....	5-22
IDE Connectors .....	5-23
Parallel Port Connector .....	5-24
SATA Ports .....	5-24
SCSI Connectors .....	5-25
5-13 Enabling SATA RAID .....	5-26

## Chapter 6: Advanced Chassis Setup

6-1 Static-Sensitive Devices .....	6-1
6-2 Control Panel.....	6-3
6-3 System Fans.....	6-4
Fan Failure .....	6-4
Replacing Chassis Fans .....	6-4
6-4 Drive Bay Installation .....	6-6
SCSI and SATA Drives .....	6-6
Installing Components in the 5.25" Drive Bays .....	6-8
6-5 Power Supply.....	6-9

---

---

Power Supply Failure .....	6-9
Removing/Replacing the Power Supply.....	6-9

**Chapter 7: BIOS**

7-1 Introduction .....	7-1
7-2 Main Setup.....	7-2
7-3 Advanced Settings Menu .....	7-2
7-4 Boot Menu .....	7-15
7-5 Security Menu .....	7-17
7-6 Exit Menu .....	7-17

**Appendices:**

Appendix A: BIOS Error Beep Codes .....	A-1
Appendix B: BIOS POST Checkpoint Codes.....	B-1
Appendix C: System Specifications .....	C-1

# Notes

# Chapter 1

## Introduction

### 1-1 Overview

The AS4040C-TR/4040C-8R is a high-end quad processor server that is comprised of two main subsystems: the SC748TQ-R1000/SC748S-R1000 1U server chassis and the H8QCE/H8QC8 serverboard. Please refer to our web site for information on operating systems that have been certified for use with the 4040C-TR/4040C-8R.

In addition to the serverboard and chassis, various hardware components have been included with the 4040C-TR/4040C-8R:

- One (1) floppy drive w/ floppy drive cable (CBL-0051L)
- Three (3) 9-cm hot-swap chassis fans (FAN-0090)
- Three (3) 8-cm exhaust fans (FAN-0081)
- Four (4) heatsink retention modules with 8 screws (BKT-0005L)
- Four (4) CPU backplates, pre-installed (BKT-0004L)
- Three (3) 5.25" dummy drive trays w/ rails (CSE-PT36)
- One (1) air shroud (CSE-PT0125)
- SATA Accessories (4040C-TR only)
  - One (1) SATA backplane (CSE-SAS-M35TQ)
  - Four (4) SATA cables (CBL-0044L)
  - Five (5) SATA drive carriers [CSE-PT39(B)]
- SCSI Accessories (4040C-8R only)
  - One (1) SCSI backplane (CSE-SCA-016)
  - One (1) SCSI cable (CBL-0063L)
  - Five (5) SCA SCSI drive carriers [CSE-PT39(B)]
- One (1) CD containing drivers and utilities

Optional:

- One (1) rackmount kit (MCP-290-00001-00)

## 1-2 Serverboard Features

At the heart of the 4040C-TR/4040C-8R lies the H8QCE/H8QC8, a quad processor serverboard based on the nVidia nForce Pro 2200 (CK804)/AMD8132 chipset. Below are the main features of the H8QCE/H8QC8. (See Figure 1-1 for a block diagram of the chipset).

### Processors

The H8QCE/H8QC8 supports four 940-pin AMD Opteron 800 Series 64-bit processors. Please refer to the serverboard description pages on our web site for a complete listing of supported processors ([www.supermicro.com/aplus/](http://www.supermicro.com/aplus/)).

### Memory

The H8QCE/H8QC8 has sixteen 184-pin DIMM slots (four for each CPU), which support up to 32 GB of registered ECC DDR400 SDRAM or up to 64 GB of registered ECC DDR333/266 SDRAM. The memory is an interleaved configuration, which requires modules of the same size and speed to be installed in pairs.

### Onboard SATA (4040C-TR only)

SATA is provided with an on-chip 3 GB/sec SATA controller. The H8QCE provides four SATA ports.

### Onboard SCSI (4040C-8R only)

Onboard SCSI is provided with an Adaptec AIC-7902W SCSI chip, which supports dual channel, Ultra320 SCSI at a throughput of 320 MB/sec for each channel. The H8QCE provides two LVD Ultra320 SCSI ports.

### Onboard Controllers/Ports

One floppy drive controller and one ATA/133/100 controller are provided to support up to four hard drives or ATAPI devices. The color-coded I/O ports include one COM port (an additional COM header is located on the serverboard), a VGA (monitor) port, two USB 2.0 ports, PS/2 mouse and keyboard ports and two G-bit Ethernet ports.

## ATI Graphics Controller

The H8QCE/H8QC8 features an integrated ATI video controller based on the Rage XL graphics chip.

## Other Features

Other onboard features that promote system health include onboard voltage monitors, a chassis intrusion header, auto-switching voltage regulators, chassis and CPU overheat sensors, virus protection and BIOS rescue.

## 1-3 Server Chassis Features

The 4040C-TR/4040C-8R is a high-end, scaleable server platform. The following is a general outline of the main features of the SC748TQ-R1000/SC748S-R1000 server chassis.

### System Power

The SC748TQ-R1000/SC748S-R1000 features a redundant 1000W power supply composed of two separate power modules. This power redundancy feature allows you to replace a failed power supply without shutting down the system.

### SATA Subsystem (4040C-TR only)

The SATA subsystem supports up to four 3 Gb/sec SATA hard drives, which are hot-swappable. The SATA drives are connected to a SATA backplane. A RAID controller card can be used with the backplane to provide data security.

**Note:** The operating system you use must have RAID support to enable the hot-swap capability of the SATA drives.

### SCSI Subsystem (4040C-8R only)

The SCSI subsystem supports up to four 80-pin SCA Ultra320 SCSI hard drives, which are hot-swappable. Any standard 3.5" drives are supported. SCA = Single Connection Attachment.) The SCSI drives are connected to a dual channel SCA backplane with SAF-TE. A RAID controller card can be used with the SCA backplane to provide data security.

**Note:** The operating system you use must have RAID support to enable the hot-swap capability of the SCSI drives.

## **PCI Expansion Slots**

The SC748TQ-R1000/SC748S-R1000 chassis supports the use of up to seven standard size (full-height, full-length) expansion cards.

## **Front Control Panel**

The control panel provides you with system monitoring and control. LEDs indicate system power, power fail, HDD activity, network activity and overheat/fan fail. A main power button and a system reset button are also included.

## **I/O Backplane**

The I/O backplane on the SC748TQ-R1000/SC748S-R1000 provides seven PCI expansion slots for standard size add-on cards, one COM port, a VGA port, two USB 2.0 ports, PS/2 mouse and keyboard ports and two gigabit Ethernet ports.

## **Cooling System**

The SC748TQ-R1000/SC748S-R1000 chassis has an innovative cooling design that includes three 9-cm hot-swap chassis fans and three 8-cm exhaust fans located at the rear of the chassis. The power supply modules also include a cooling fan. All chassis and power supply fans operate continuously.

A setting in BIOS (see Chapter 7) is used to control the system fan speed. This setting uses voltage control to allow fans to run at different speeds.

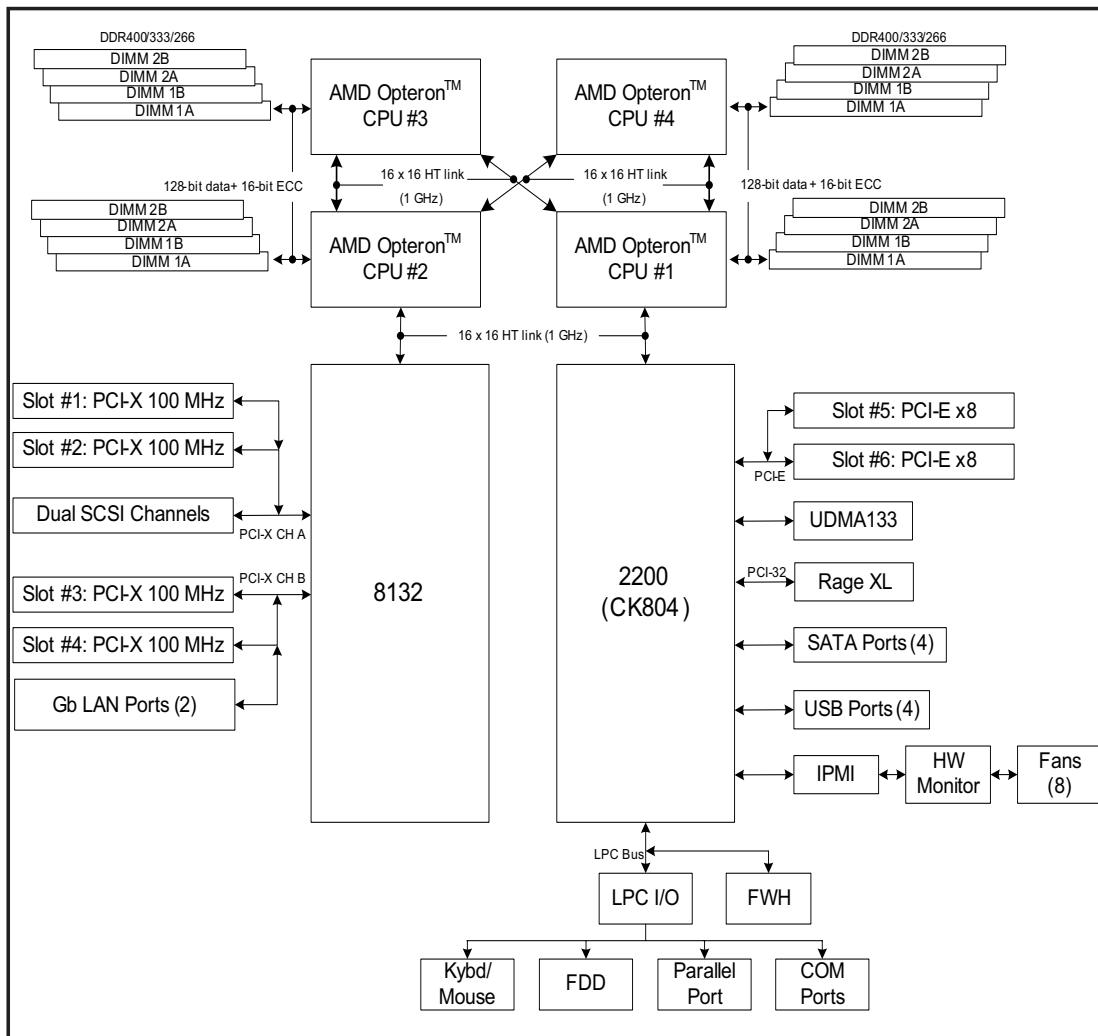

**Figure 1-1. nVidia nForce Pro 2200/AMD 8132 Chipset:  
System Block Diagram**

**Note:** This is a general block diagram and may not exactly represent the features on your serverboard. See the previous pages for the actual specifications of your serverboard.

# Notes

# Chapter 2

## Server Installation

### 2-1 Overview

This chapter provides a quick setup checklist to get your AS4040C-TR/4040C-8R up and running. Following these steps in the order given should enable you to have the system operational within a minimum amount of time. This quick setup assumes that your system has come to you with the processors and memory preinstalled. If your system is not already fully integrated with a serverboard, processors, system memory etc., please turn to the chapter or section noted in each step for details on installing specific components. The 4040C-TR/4040C-8R may be employed either as a tower or mounted in a rack as a 4U rackmount chassis. If using it as a tower unit, please read the Server Precautions in the next section and then skip ahead to Section 2-5.

### 2-2 Unpacking the System

You should inspect the box the system was shipped in and note if it was damaged in any way. If the server itself shows damage you should file a damage claim with the carrier who delivered it.

Decide on a suitable location for the 4040C-TR/4040C-8R. It should be situated in a clean, dust-free area that is well ventilated. Avoid areas where heat, electrical noise and electromagnetic fields are generated. You will also need it placed near a grounded power outlet. Be sure to read the Rack and Server Precautions in the next section.

### 2-3 Preparing for Setup

The box the system was shipped in may include two sets of rail assemblies, two rail mounting brackets and mounting screws needed for installing the system into a rack (optional kit). Follow the steps in the order given to complete the installation process in a minimum amount of time. Please read this section in its entirety before you begin the installation procedure outlined in the sections that follow.

## Choosing a Setup Location

- Leave enough clearance in front of the system to enable you to open the front door completely (~25 inches).
- Leave approximately 30 inches of clearance in the back of the system to allow for sufficient airflow and ease in servicing.
- This product is for installation only in a Restricted Access Location (dedicated equipment rooms, service closets and the like).



## Warnings and Precautions!



### Rack Precautions

- Ensure that the leveling jacks on the bottom of the rack are fully extended to the floor with the full weight of the rack resting on them.
- In single rack installation, stabilizers should be attached to the rack.
- In multiple rack installations, the racks should be coupled together.
- Always make sure the rack is stable before extending a component from the rack.
- You should extend only one component at a time - extending two or more simultaneously may cause the rack to become unstable.

### Server Precautions

- Review the electrical and general safety precautions in Chapter 4.
- Determine the placement of each component in the rack *before* you install the rails.
- Install the heaviest server components on the bottom of the rack first, and then work up.
- Use a regulating uninterruptible power supply (UPS) to protect the server from power surges, voltage spikes and to keep your system operating in case of a power failure.
- Allow the hot plug SATA/SCSI drives and power supply units to cool before touching them.
- Always keep the rack's front door and all server panels and covers closed when not servicing to maintain proper cooling.

## **Rack Mounting Considerations**

### **Ambient Operating Temperature**

If installed in a closed or multi-unit rack assembly, the ambient operating temperature of the rack environment may be greater than the ambient temperature of the room. Therefore, consideration should be given to installing the equipment in an environment compatible with the manufacturer's maximum rated ambient temperature ( $T_{mra}$ ).

### **Reduced Airflow**

Equipment should be mounted into a rack so that the amount of airflow required for safe operation is not compromised.

### **Mechanical Loading**

Equipment should be mounted into a rack so that a hazardous condition does not arise due to uneven mechanical loading.

### **Circuit Overloading**

Consideration should be given to the connection of the equipment to the power supply circuitry and the effect that any possible overloading of circuits might have on overcurrent protection and power supply wiring. Appropriate consideration of equipment nameplate ratings should be used when addressing this concern.

### **Reliable Ground**

A reliable ground must be maintained at all times. To ensure this, the rack itself should be grounded. Particular attention should be given to power supply connections other than the direct connections to the branch circuit (i.e. the use of power strips, etc.).

## 2-4 Installing the System into a Rack

This section provides information on installing the system into a rack unit. Rack installation requires the use of the optional rackmount kit. If the system has already been mounted into a rack or if you are using it as a tower, you can skip ahead to Sections 2-5 and 2-6. There are a variety of rack units on the market, which may mean the assembly procedure will differ slightly. The following is a guideline for installing the server into a rack with the rack rails provided in the rackmount kit. You should also refer to the installation instructions that came with the rack unit you are using.

### Identifying the Sections of the Rack Rails

The optional rackmount kit (MCP-290-00001-00) includes two rack rail assemblies. Each of these assemblies consist of two sections: an inner fixed chassis rail that secures to the chassis and an outer rack rail that secures directly to the rack itself. The inner and outer rails must be detached from each other before installing.

To remove the inner chassis rail, pull it out as far as possible - you should hear a "click" sound as a locking tab emerges from inside the rail assembly and locks the inner rail. Depress the locking tab to pull the inner rail completely out. Do this for both assemblies (one for each side).

**Figure 2-1. Inner Fixed Chassis Rail**

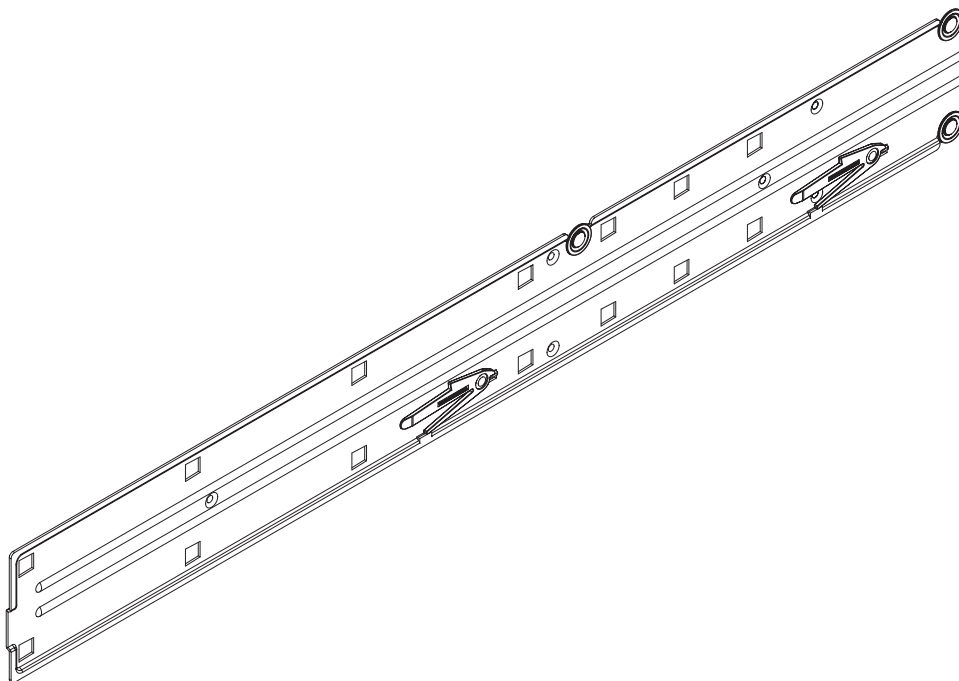

## Installing the Chassis Rails

You will need to remove the top bezel cover and the feet to add rack rails to the chassis. First, remove the top and right covers (top and left covers when standing as a tower chassis) by depressing the latch on the rear lip of the top (side if tower) cover to release it - then push the cover off. Finally, unscrew the four feet and remove them from the chassis (see Figure 2-2).

You can now attach rack rails to the top and bottom (now the sides) of the chassis. First add the rack handles. Then position the inner chassis rail sections you just removed along the side of the chassis making sure the screw holes line up. Note that these two rails are left/right specific. Screw the rail securely to the side of the chassis (see Figure 2-3). Repeat this procedure for the other rail on the other side of the chassis. You will also need to attach the rail brackets when installing into a telco rack.

**Locking Tabs:** The chassis rails have locking tabs that serve to lock the server into place when installed and pushed fully into the rack, which is its normal position.

**Figure 2-2. Preparing to Install the Chassis Rails**

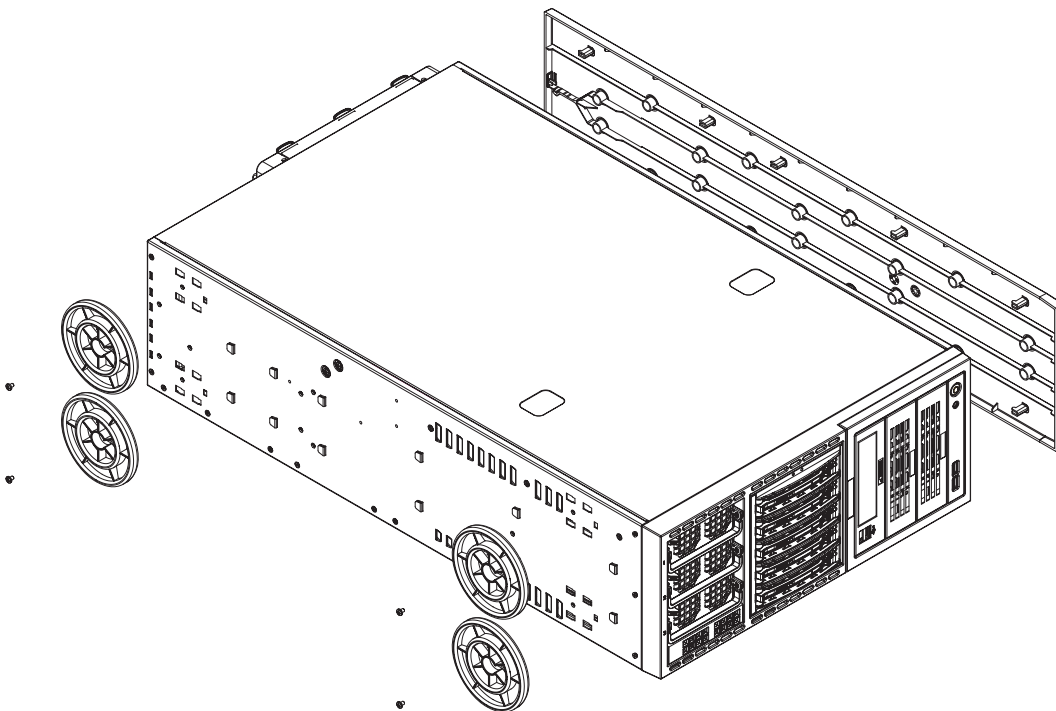

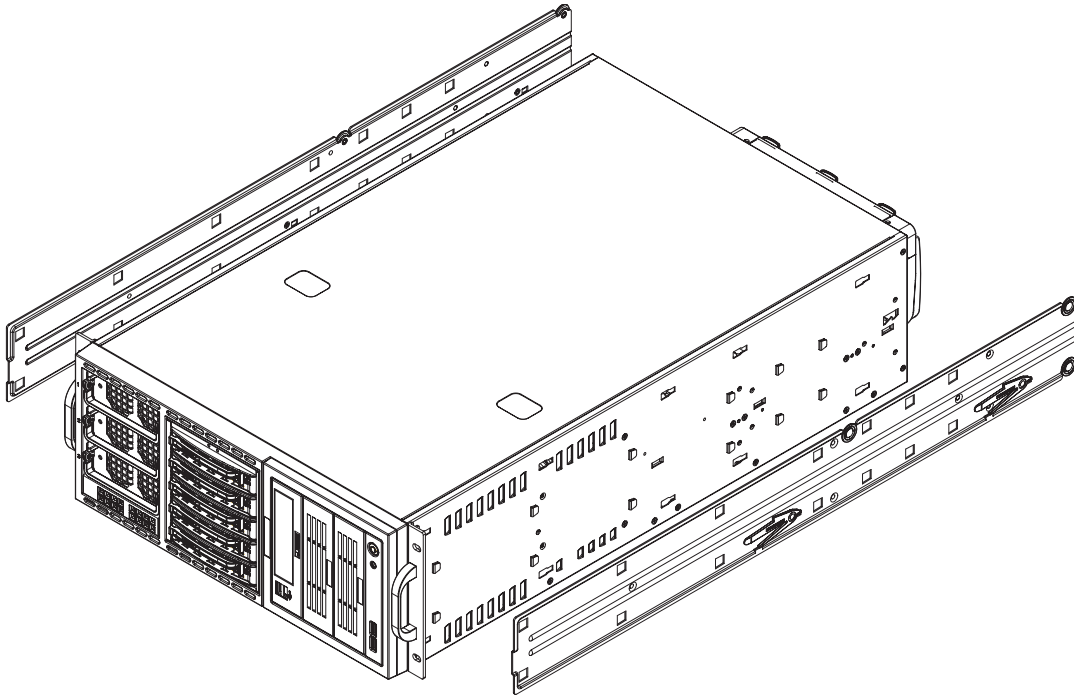
**Figure 2-3. Installing the Rails to the Chassis**

## Installing the Rack Rails

Determine where you want to place the 4040C-TR/4040C-8R in the rack. ([See Rack and Server Precautions in Section 2-3.](#)) Position the fixed rack rail/sliding rail guide assemblies at the desired location in the rack, keeping the sliding rail guide facing the inside of the rack. Screw the assembly securely to the rack using the brackets provided. Attach the other assembly to the other side of the rack, making sure both are at the exact same height and with the rail guides facing inward.

## Installing the Server into the Rack

You should now have rails attached to both the chassis and the rack unit. The next step is to install the server into the rack. You should have two brackets in the rack mount kit. Install these first keeping in mind that they are left/right specific (marked with "L" and "R"). Then, line up the rear of the chassis rails with the front of the rack rails. Slide the chassis rails into the rack rails, keeping the pressure even on both sides (you may have to depress the locking tabs when inserting).

When the server has been pushed completely into the rack, you should hear the locking tabs "click". Finish by inserting and tightening the thumbscrews that hold the front of the server to the rack (see Figure 2-4).

**Figure 2-4. Installing the Server into a Rack**

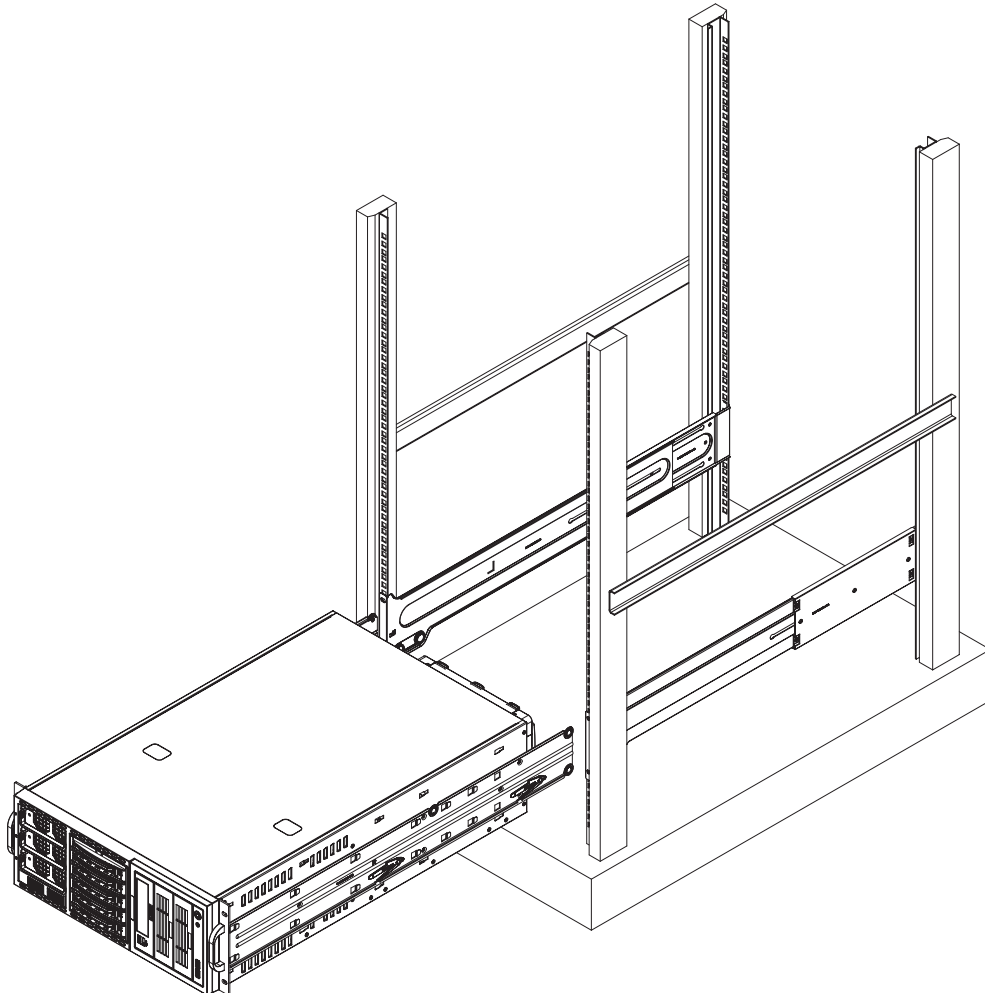

## 2-5 Checking the Serverboard Setup

After setting up the the system, you will need to open the unit to make sure the serverboard is properly installed and all the connections have been made.

### 1. Accessing the inside of the system (see Figure 2-5)

(If rack mounted, first release the retention screws that secure the unit to the rack. Grasp the two handles on either side and pull the unit straight out until it locks (you will hear a "click".) There are two screws that secure the cover to the chassis - remove these first. Using the indentations on the side cover (see Figure 2-5), push the cover to slide it off the chassis. You can then lift the cover from the chassis to gain full access to the inside of the server.

### 2. Check the CPUs (processors)

You may have four processors already installed into the serverboard. Each processor should have its own heatsink attached. See Chapter 5 for instructions on processor installation.

### 3. Check the system memory

Your server may have come with system memory already installed. Make sure all DIMMs are fully seated in their slots. For details on adding system memory, refer to Chapter 5.

### 4. Installing add-on cards

If desired, you can install add-on cards to the system. See Chapter 5 for details on installing PCI add-on cards.

### 5. Check all cable connections and airflow

Make sure all power and data cables are properly connected and not blocking the chassis airflow. See Chapter 5 for details on cable connections.

## 2-6 Checking the Drive Bay Setup

Next, you should check to make sure the peripheral drives and the SATA/SCSI drives and backplane have been properly installed and all connections have been made.

### 1. Accessing the drive bays

All drives can be accessed from the front of the server. For servicing the CD-ROM, IDE hard drives and floppy drives, you will need to remove the top/left chassis cover. The SATA/SCSI disk drives can be installed and removed from the front of the chassis without removing any chassis covers.

### 2. Installing components into the 5.25" drive bays

To install components into the 5.25" drive bays, you must first remove the top/left chassis cover as described in the previous section. Refer to Chapter 6 for details.

### 3. Installing CD-ROM and floppy disk drives

Refer to Chapter 6 if you need to reinstall a CD-ROM and/or floppy disk drive to the system.

### 4. Check the SATA/SCSI disk drives

Depending upon your system's configuration, your system may have one or more drives already installed. If you need to install SATA/SCSI drives, please refer to Chapter 6.

### 5. Check the airflow

Airflow is provided by three 9-cm hot-swap chassis fans working in conjunction with three 8-cm exhaust fans, which are located at the rear of the chassis. The system component layout was carefully designed to promote sufficient airflow through the chassis. Also note that all power and data cables have been routed in such a way that they do not block the airflow generated by the fans. Keep this in mind when you reroute them after working on the system.

### 6. Supplying power to the system

The last thing you must do is to provide input power to the system. Plug the power cords from the power supplies unit into a high-quality power strip that offers protection from electrical noise and power surges. It is recommended that you use an uninterruptible power supply (UPS). Finally, depress the power on button on the front of the chassis.

**Figure 2-5. Accessing the Inside of the System  
(Rack Configuration shown)**

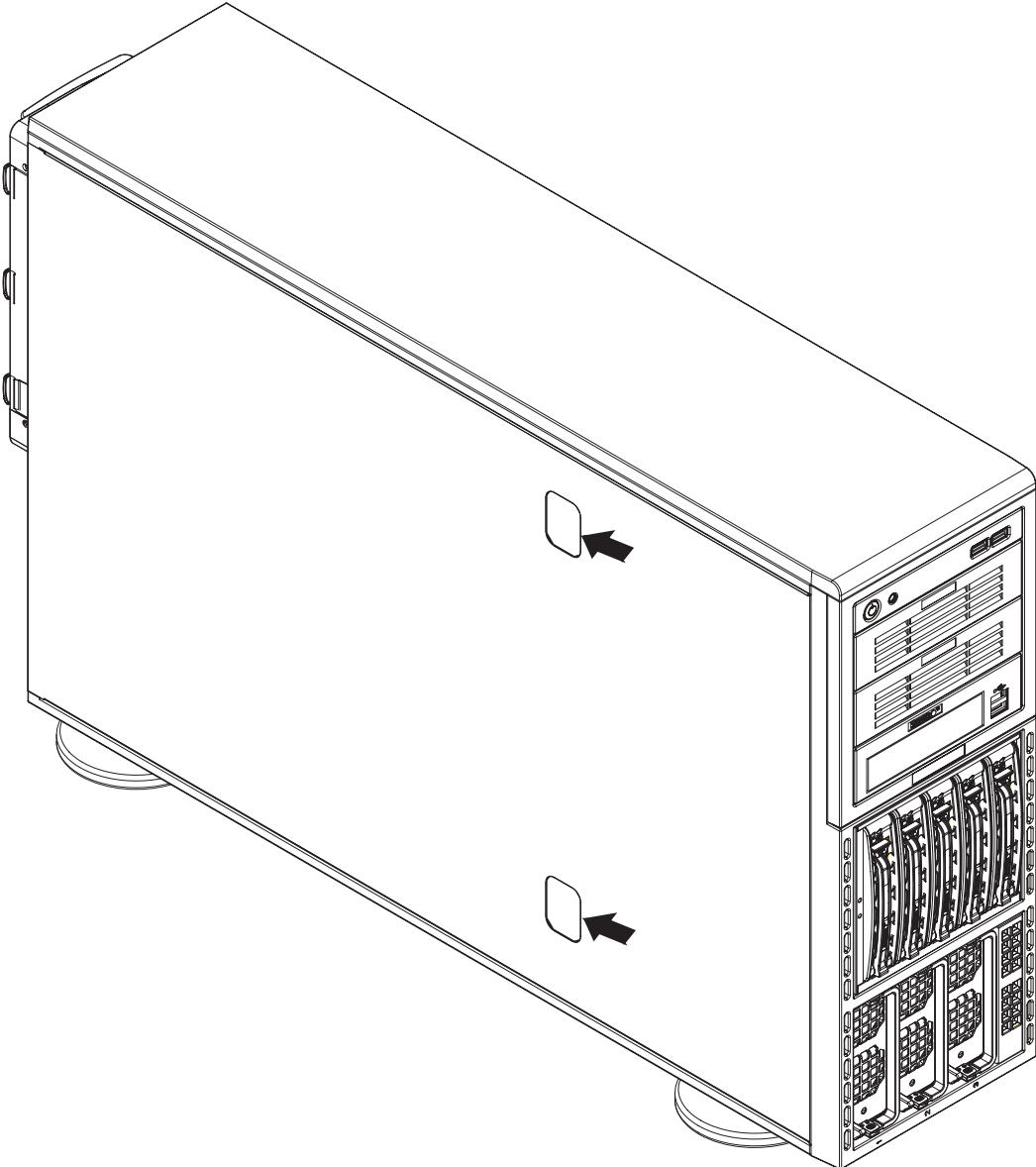

---

## Chapter 3

### System Interface

#### 3-1 Overview

There are several LEDs on the control panel as well as others on the SATA/SCSI drive carriers to keep you constantly informed of the overall status of the system as well as the activity and health of specific components. There are also two buttons on the chassis control panel. This chapter explains the meanings of all LED indicators and the appropriate response you may need to take.

#### 3-2 Control Panel Buttons

There are two push-buttons located on the front of the chassis. These are (in order from left to right) a reset button and a power on/off button.

RESET

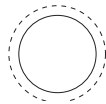

- **Reset:** Use the reset switch to reboot the system.

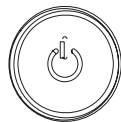

- **Power:** The main power switch is used to apply or remove power from the power supply to the server system. Turning off system power with this button removes the main power but keeps standby power supplied to the system.

### 3-3 Control Panel LEDs

The control panel located on the front of the SC748TQ-R1000/SC748S-R1000 chassis has five LEDs. These LEDs provide you with critical information related to different parts of the system. This section explains what each LED indicates when illuminated and any corrective action you may need to take.



- **Power Fail:** Indicates a power supply module has failed. This should be accompanied by an audible alarm. A backup power supply module will take the load and keep the system running but the failed module will need to be replaced. Refer to Chapter 6 for details on replacing failed power supply modules. This LED should be off when the system is operating normally.



- **Overheat/Fan Fail:** When this LED flashes it indicates a fan failure. When on continuously (on and not flashing) it indicates an overheat condition, which may be caused by cables obstructing the airflow in the system or the ambient room temperature being too warm. Check the routing of the cables and make sure all fans are present and operating normally. You should also check to make sure that the chassis covers are installed. Finally, verify that the heatsinks are installed properly (see Chapter 5). This LED will remain flashing or on as long as the overheat condition exists.



- **NIC2:** Indicates network activity on GLAN2 when flashing .



- **NIC1:** Indicates network activity on GLAN1 when flashing.



- **HDD:** Indicates IDE channel activity. On the 4040C-TR/4040C-8R, this light indicates SATA/SCSI and/or CD-ROM drive activity when flashing.



- **Power:** Indicates power is being supplied to the system's power supply units. This LED should normally be illuminated when the system is operating.

## 3-4 Drive Carrier LEDs

### SATA Drives (4040C-TR)

Each SATA drive carrier has two LEDs.

- **Green:** When illuminated, the green LED on the front of the SATA drive carrier indicates drive activity. A connection to the SATA backplane enables this LED to blink on and off when that particular drive is being accessed.
- **Red:** The red LED indicates two states. When blinking, it indicates the drive is rebuilding. When solid, it indicates a drive failure. If a SATA drive fails, you should be notified by your system management software. Please refer to Chapter 6 for instructions on replacing failed SATA drives.

### SCSI Drives (4040C-8R)

Each SCSI drive carrier has two LEDs.

- **Green:** When illuminated, the green LED on the front of the SCSI drive carrier indicates drive activity. A connection to the SCSI SCA backplane enables this LED to blink on and off when that particular drive is being accessed.

- **Red:** The SAF-TE compliant backplane activates the red LED to indicate a drive failure. If one of the SCSI drives fail, you should be notified by your system management software. Please refer to Chapter 6 for instructions on replacing failed SCSI drives.

## Chapter 4

### System Safety

#### 4-1 Electrical Safety Precautions



Basic electrical safety precautions should be followed to protect yourself from harm and the AS4040C-TR/4040C-8R from damage:

- Be aware of the locations of the power on/off switch on the chassis as well as the room's emergency power-off switch, disconnection switch or electrical outlet. If an electrical accident occurs, you can then quickly remove power from the system.
- Do not work alone when working with high voltage components.
- Power should always be disconnected from the system when removing or installing main system components, such as the serverboard, memory modules and the CD-ROM and floppy drives (not necessary for SATA or SCSI drives). When disconnecting power, you should first power down the system with the operating system and then unplug the power cords from all the power supply modules in the system.
- When working around exposed electrical circuits, another person who is familiar with the power-off controls should be nearby to switch off the power if necessary.
- Use only one hand when working with powered-on electrical equipment. This is to avoid making a complete circuit, which will cause electrical shock. Use extreme caution when using metal tools, which can easily damage any electrical components or circuit boards they come into contact with.
- Do not use mats designed to decrease electrostatic discharge as protection from electrical shock. Instead, use rubber mats that have been specifically designed as electrical insulators.
- The power supply power cord must include a grounding plug and must be plugged into grounded electrical outlets.

- Serverboard Battery: **CAUTION** - There is a danger of explosion if the onboard battery is installed upside down, which will reverse its polarities (see Figure 4-1). This battery must be replaced only with the same or an equivalent type recommended by the manufacturer. Dispose of used batteries according to the manufacturer's instructions.
- CD-ROM Laser: **CAUTION** - this server may have come equipped with a CD-ROM drive. To prevent direct exposure to the laser beam and hazardous radiation exposure, do not open the enclosure or use the unit in any unconventional way.

## 4-2 General Safety Precautions



Follow these rules to ensure general safety:

- Keep the area around the 4040C-TR/4040C-8R clean and free of clutter.
- The 4040C-TR/4040C-8R weighs approximately 65.5 lbs (29.7 kg) when fully loaded. When lifting the system, two people at either end should lift slowly with their feet spread out to distribute the weight. Always keep your back straight and lift with your legs.
- Place the chassis top cover and any system components that have been removed away from the system or on a table so that they won't accidentally be stepped on.
- While working on the system, do not wear loose clothing such as neckties and unbuttoned shirt sleeves, which can come into contact with electrical circuits or be pulled into a cooling fan.
- Remove any jewelry or metal objects from your body, which are excellent metal conductors that can create short circuits and harm you if they come into contact with printed circuit boards or areas where power is present.
- After accessing the inside of the system, close the system back up and secure it to the rack unit with the retention screws after ensuring that all connections have been made.

### 4-3 ESD Precautions



Electrostatic discharge (ESD) is generated by two objects with different electrical charges coming into contact with each other. An electrical discharge is created to neutralize this difference, which can damage electronic components and printed circuit boards. The following measures are generally sufficient to neutralize this difference before contact is made to protect your equipment from ESD:

- Use a grounded wrist strap designed to prevent static discharge.
- Keep all components and printed circuit boards (PCBs) in their antistatic bags until ready for use.
- Touch a grounded metal object before removing any board from its antistatic bag.
- Do not let components or PCBs come into contact with your clothing, which may retain a charge even if you are wearing a wrist strap.
- Handle a board by its edges only; do not touch its components, peripheral chips, memory modules or contacts.
- When handling chips or modules, avoid touching their pins.
- Put the serverboard and peripherals back into their antistatic bags when not in use.
- For grounding purposes, make sure your computer chassis provides excellent conductivity between the power supply, the case, the mounting fasteners and the serverboard.

## 4-4 Operating Precautions



Care must be taken to assure that the chassis cover is in place when the 4040C-TR/4040C-8R is operating to ensure proper cooling. Out of warranty damage to the 4040C-TR/4040C-8R system can occur if this practice is not strictly followed.

**Figure 4-1. Installing the Onboard Battery**

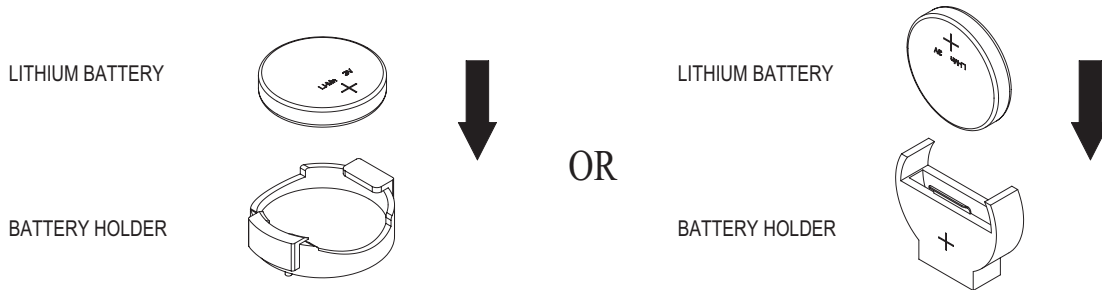

## Chapter 5

# Advanced Serverboard Setup

This chapter covers the steps required to install processors and heatsinks to the H8QCE/H8QC8 serverboard, connect the data and power cables and install add-on cards. All serverboard jumpers and connections are described and a layout and quick reference chart are included in this chapter. Remember to close the chassis completely when you have finished working on the serverboard to protect and cool the system sufficiently.

### 5-1 Handling the Serverboard

Static electrical discharge can damage electronic components. To prevent damage to printed circuit boards, it is important to handle them very carefully (see Chapter 4). Also note that the size and weight of the serverboard can cause it to bend if handled improperly, which may result in damage. To prevent the serverboard from bending, keep one hand under the center of the board to support it when handling. The following measures are generally sufficient to protect your equipment from static discharge.

#### Precautions

- Use a grounded wrist strap designed to prevent static discharge.
- Touch a grounded metal object before removing any board from its antistatic bag.
- Handle a board by its edges only; do not touch its components, peripheral chips, memory modules or gold contacts.
- When handling chips or modules, avoid touching their pins.
- Put the serverboard, add-on cards and peripherals back into their antistatic bags when not in use.

#### Unpacking

The serverboard is shipped in antistatic packaging to avoid static damage. When unpacking the board, make sure the person handling it is static protected.

## 5-2 Mounting the Serverboard into a Chassis

All serverboards and motherboards have standard mounting holes to fit different types of chassis. Make sure that the locations of all the mounting holes for both the serverboard and the chassis match. Although a chassis may have both plastic and metal mounting fasteners, metal ones are highly recommended because they ground the serverboard to the chassis. Make sure that the metal standoffs click in or are screwed in tightly.

### 1. Check the compatibility of the serverboard ports and the I/O shield

The H8QCE/H8QC8 serverboard requires a chassis that can support extended ATX boards of 16.4" x 13" in size, such as the SC818S+-1000. Make sure that the I/O ports on the serverboard align with their respective holes in the I/O shield at the rear of the chassis.

### 2. Mounting the serverboard onto the mainboard tray in the chassis

Carefully mount the serverboard onto the mainboard tray by aligning the serverboard mounting holes with the raised metal standoffs in the tray. Insert screws into all the mounting holes in the serverboard that line up with the standoffs. Then use a screwdriver to secure the serverboard to the mainboard tray - tighten until just snug (if too tight you might strip the threads). Metal screws provide an electrical contact to the serverboard ground to provide a continuous ground for the system.

## Installing the CPU Backplates

Four CPU backplates (BKT-0004) are included in the retail box. The backplates prevent the CPU area of the serverboard from bending and provide a base for attaching the heatsink retention modules. To install, begin by peeling off the release paper to expose the adhesive. On the underside of the serverboard, locate the two holes on either side of the CPU socket. Attach the adhesive side of the backplate to the board by inserting the standoffs into the two holes and applying light pressure so that the backplate sticks to the underside of the board. Repeat for all CPU sockets. See Figure 5-1.

## 5-3 Processor and Heatsink Installation



*Exercise extreme caution when handling and installing the processor. Always connect the power cord last and always remove it before adding, removing or changing any hardware components.*

### Installing the Processor (must populate all four CPU sockets)

1. Lift the lever on CPU socket #1 until it points straight up.



2. Use your thumb and your index finger to hold the CPU. Locate pin 1 on the CPU socket and pin 1 on the CPU. Both are marked with a triangle.

Triangles



3. Align pin 1 of the CPU with pin 1 of the socket. Once aligned, carefully place the CPU into the socket. *Do not drop the CPU on the socket, move the CPU horizontally or vertically or rub the CPU against the socket or against any pins of the socket, which may damage the CPU and/or the socket.*



4. With the CPU inserted into the socket, inspect the four corners of the CPU to make sure that it is properly installed and flush with the socket.



5. Gently press the CPU socket lever down until it locks in the plastic tab. Repeat these steps to install additional CPUs into the other three sockets.



## Installing the Heatsink Retention Modules

Four heatsink retention modules (BKT-0005) and eight screws are included in the retail box. Once installed, these are used to help attach the heatsinks to the CPUs. To install, position the module so that the CPU backplate standoffs insert through the holes on the heatsink retention module and the four feet on the module contact the serverboard. Secure the retention module to the backplate with two of the screws provided. See Figure 5-1. Repeat for the second CPU socket.

**Note:** BKT-0005 is included for use with non-proprietary heatsinks only. When installing Supermicro heatsinks, only BKT-0004 (CPU backplate) is needed. The BKT-0005 retention module was designed to provide compatibility with clip-and-cam type heatsinks from third parties.

## Installing the Heatsinks

To install the heatsink (SNK-P0012, optional), do not apply any thermal compound to the heatsink or CPU die - the proper amount has already been applied. Place the heatsink directly on the CPU so that the two mounting holes are aligned with those on the CPU backplate. Make sure the heatsink sits completely flat on the CPU - if not completely flat, the space between the two will degrade the heat dissipation function of the heatsink, which may cause the processor to overheat. Screw in the two screws until just snug (do not fully tighten), then finish by fully tightening both screws.

**Figure 5-1. CPU Backplate/Heatsink Retention Module Installation**

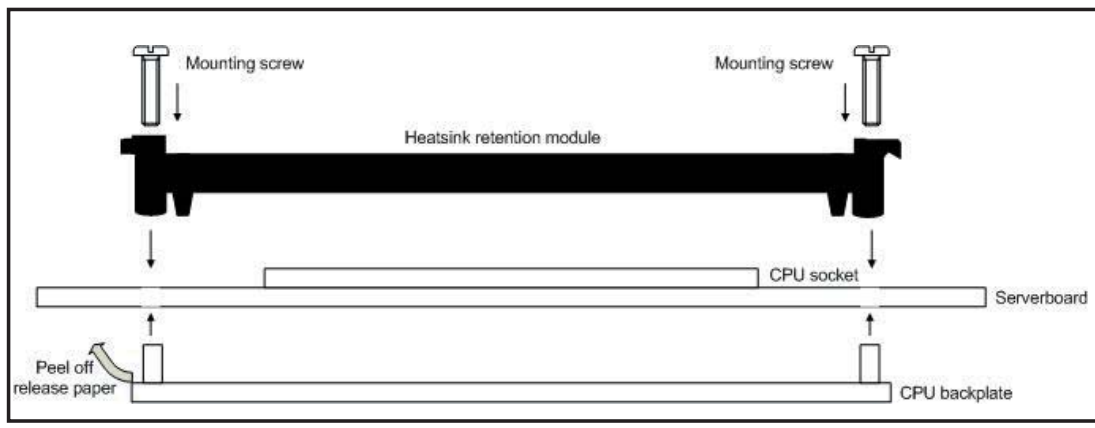

## 5-4 Connecting Cables

Now that the processors are installed, the next step is to connect the cables to the serverboard. These include the data (ribbon) cables for the peripherals and control panel and the power cables.

### Connecting Data Cables

The ribbon cables used to transfer data from the peripheral devices have been carefully routed in to prevent them from blocking the airflow through the chassis. If you need to disconnect any of these cables, you should take care to reroute them as they were originally when reconnecting them (make sure the red wires connect to the pin 1 locations). The following data cables (with their serverboard connector locations noted) should be connected (refer to the serverboard layout diagram for connector locations).

- CD-ROM cable (JIDE1)
- Floppy Drive cable (Floppy)
- Control Panel cable (JF1, see next page)
- 4040C-TR: SATA cables (SATA0-SATA2)
- 4040C-8R: SCSI cables (JA1, JA2)

### Connecting Power Cables

The H8QCE/H8QC8 has a 24-pin primary power supply connector "J1B1" for connection to the ATX power supply. Connect the appropriate connector from the power supply to J1B1 connector to supply power to the serverboard. See the Connector Definitions section in this chapter for power connector pin definitions.

In addition, your power supply must be connected to the 8-pin Auxilliary power connectors (at JPW1 and JPW2, respectively).

### Connecting the Control Panel

JF1 contains header pins for various front control panel connectors. See Figure 5-2 for the pin locations of the various front control panel buttons and LED indicators and refer to section 5-9 for details. Note that even and odd numbered pins are on opposite sides of each header.

---

All JF1 wires have been bundled into single keyed ribbon cable to simplify the connection. The red wire in the ribbon cable plugs into pin 1 of JF1. Connect the other end of the cable to the Control Panel printed circuit board, located just behind the system status LEDs in the chassis. **Note:** NC indicates no connection.

**Figure 5-2. Front Control Panel Header Pins (JF1)**

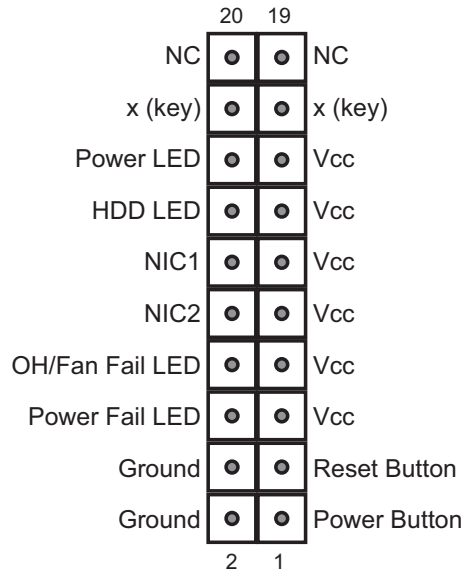

## 5-5 I/O Ports

The I/O ports are color coded in conformance with the PC 99 specification. See Figure 5-3 below for the colors and locations of the various I/O ports.

**Figure 5-3. Rear Panel I/O Ports**

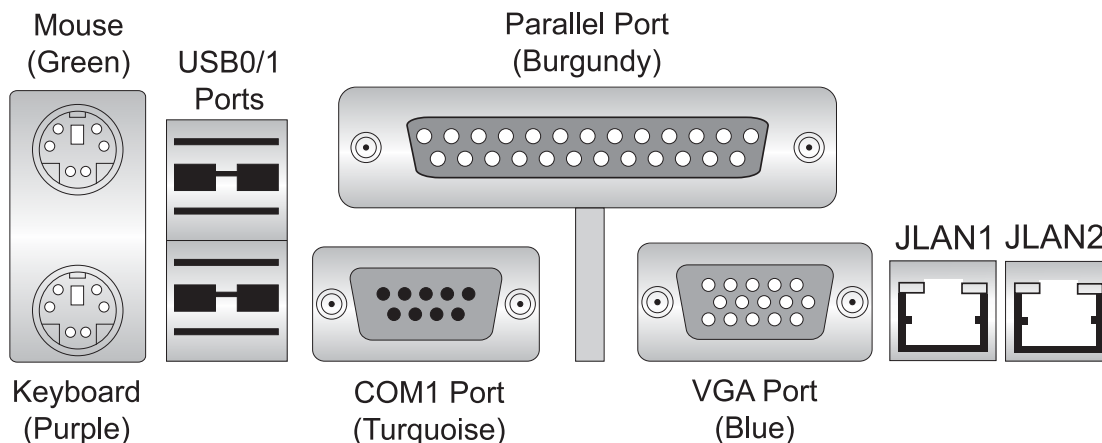

## 5-6 Installing Memory

---

### **CAUTION**

Exercise extreme care when installing or removing memory modules to prevent any possible damage.

---

1. Insert each memory module vertically into its slot, paying attention to the notch along the bottom of the module to prevent inserting the module incorrectly (see Figure 5-4). For each bank of four DIMM slots, install first into DIMM 1A, then 1B, then 2A, then 2B. See support information and notes on optimizing memory performance below.
2. Gently press down on the memory module until it snaps into place.

**Note:** Each processor has its own built-in memory controller. 256 MB, 512 MB, 1 GB, 2 GB and 4 GB memory modules are supported. It is highly recommended that you remove the power cord from the system before installing or changing DIMMs.

### **Support**

The H8QC8/H8QCE supports single or dual-channel, registered ECC DDR400/333/266 SDRAM.

Both interleaved and non-interleaved memory are supported, so you may populate any number of DIMM slots (see note on previous page).

Populating two adjacent slots at a time with memory modules of the same size and type will result in interleaved (128-bit) memory, which is faster than non-interleaved (64-bit) memory.

### **Optimizing memory performance**

With the mandatory four processors installed, it is better to spread out pairs of DIMMs across all four CPU memory banks than filling up one CPU memory bank while leaving any others empty. For example, if you were to install eight DIMMs you should install two in the CPU1 DIMM slots, two in the CPU2 DIMM slots, two in the CPU3 DIMM slots and two in the CPU4 DIMM slots (slots 1A and 1B in each of the four banks) rather than four in any single CPU bank of four slots. If you install four more, install two in the remaining CPU1 DIMM slots and two in the the remaining CPU2 DIMM slots, etc. This balances the load over all CPUs to optimize performance.

**Maximum memory:** 64 GB for DDR333/266 and 32 GB for DDR400.

**Figure 5-4. Side and Top Views of DDR Installation****To Install:**

Insert module vertically and press down until it snaps into place. The release tabs should close - if they do not you should close them yourself.

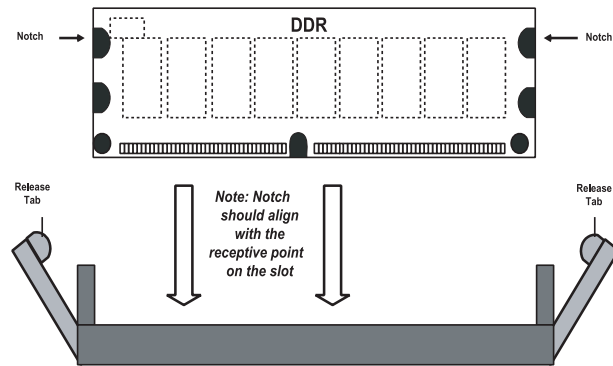

Note the notch in the slot and on the bottom of the DIMM. These prevent the DIMM from being installed incorrectly.

**To Remove:**

Use your thumbs to gently push each release tab outward to release the DIMM from the slot.



## 5-7 Adding PCI Cards

### 1. PCI slots:

The H8QCE/H8QC8 has six PCI expansion slots. All slots may be populated with add-on cards in the SC748TQ-R1000/SC748S-R1000 chassis.

### 2. PCI card installation:

To install a PCI add-on card, begin by removing the screw from the backpanel PCI slot shield that covers the PCI expansion slot. Insert the PCI card into the riser card, pushing down with your thumbs evenly on both sides of the card. Finish by securing the card to the chassis with the same screw you removed from the PCI shield.

**Note:** the PCI slot shields help promote proper airflow in the chassis and shield the inside of the system from EMI (electromagnetic interference). For these reasons, make sure there is always a shield covering each unused slot.

## 5-8 Serverboard Details

Figure 5-5. H8QC8 Serverboard Layout  
(not drawn to scale)

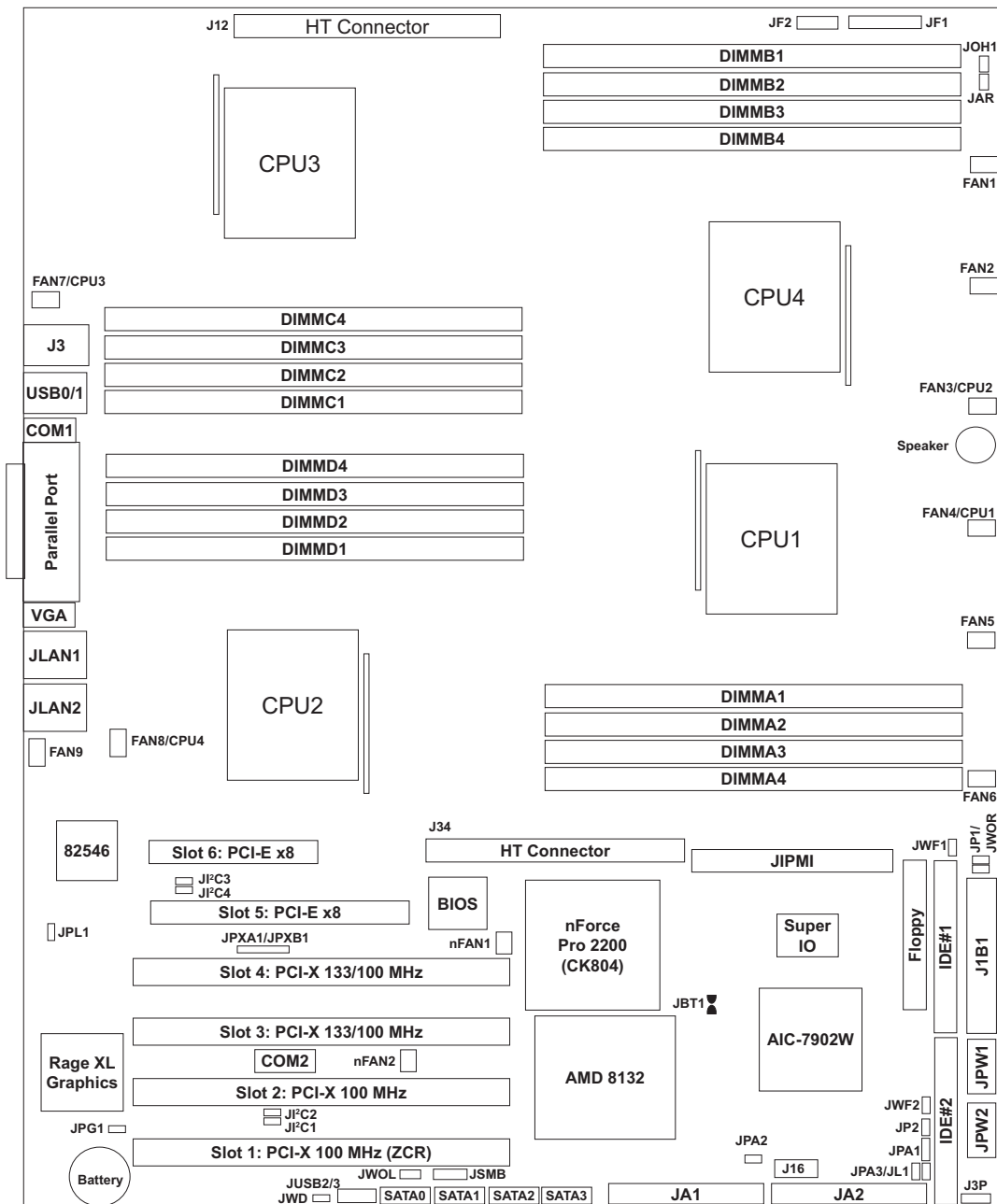

**Note:** Jumpers not indicated are for test purposes only. The H8QCE shares the same layout but does not include SCSI controllers, connectors, or jumpers.

## H8QC8/H8QCE Quick Reference

<b>Jumpers</b>	<b>Description</b>	<b>Default Setting</b>
J3P	3rd Power Fail Detect	Open (Disabled)
JBT1	CMOS Clear	See Section 5-10
JP1/JP2	Compact Flash Drive Select	Both Closed (Master)
JPA1*	SCSI Enable/Disable	Pins 1-2 (Enabled)
JPA2/JPA3*	SCSI CH A/B Termination	Both Open (Enabled)
JPG1	VGA Enable/Disable	Pins 1-2 (Enabled)
JPL1	GLAN Enable/Disable	Pins 1-2 (Enabled)
JWD	Watch Dog	Pins 1-2 (Reset)
<b>Connectors</b>	<b>Description</b>	
COM1, COM2	COM1/COM2 Serial Port/Header	
FAN 1-9	System/CPU Fan Headers	
Floppy	Floppy Disk Drive Connector	
IDE#1/IDE#2	IDE#1/IDE#2 Connectors	
J1B1	24-Pin ATX Power Connector	
J3	PS/2 Keyboard/Mouse Ports	
J16	I <sup>2</sup> C Header for Power Supply	
J34	HT Connectors	
JA1/JA2*	U320 SCSI Channel A/B Connector	
JAR	3rd Power Supply Alarm Reset Header	
JF1	Front Panel Connector	
JF2	Onboard Speaker/Keylock/Power LED	
JIPMI	IPMI Daughter Card Slot	
JL1	Chassis Intrusion Header	
JLAN1/2	Gigabit Ethernet (RJ45) Ports	
JOH1	Overheat Warning Header	
JPW1	Auxiliary 1 Power Connector	
JPW2	Auxiliary 2 Power Connector	
JSMB	System Management Bus Header	
JWF1/2	Compact Flash Power Headers	
JWOL	Wake-On-LAN Header	
JWOR	Wake-On-Ring Header	
nFAN1/4	Additional Fan Headers (nFAN3/4 used with air shroud)	
SATA0-3	Serial ATA Connectors	
Speaker	Onboard Speaker (Buzzer)	
USB0/1	Universal Serial Bus (USB) Ports 0/1	
USB2/3	USB2/3 Headers	

\*H8QC8 only

## 5-9 Connector Definitions

### ATX Power Connector

The primary ATX power supply connector (J1B1) meets the SSI (Super-set ATX) 24-pin specification. Refer to the table on the right for the pin definitions of the ATX 24-pin power connector. This connection supplies power to the chipset, fans and memory.

**Note:** You must also connect the 8-pin JPW1 and JPW2 power connectors to your power supply (see below).

ATX Power 24-pin Connector Pin Definitions (J1B1)			
Pin#	Definition	Pin #	Definition
13	+3.3V	1	+3.3V
14	-12V	2	+3.3V
15	COM	3	COM
16	PS_ON	4	+5V
17	COM	5	COM
18	COM	6	+5V
19	COM	7	COM
20	Res (NC)	8	PWR_OK
21	+5V	9	5VSB
22	+5V	10	+12V
23	+5V	11	+12V
24	COM	12	+3.3V

### Auxiliary 1 Power Connector

In addition to the primary ATX power connector (above), the 8-pin Auxiliary 1 power connector at JPW1 must also be connected to your power supply. See the table on the right for pin definitions.

Auxiliary 1 Power Connector Pin Definitions (JPW1)	
Pins	Definition
1 through 4	Ground
5 through 8	+12V

**Required Connection**

### Auxiliary 2 Power Connector

The 8-pin Auxiliary 2 power connector at JPW2 must also be connected to your power supply. See the table on the right for pin definitions.

Auxiliary 2 Power Connector Pin Definitions (JPW2)	
Pins	Definition
1 through 4	Ground
5 through 8	+12V

**Required Connection**

### Power LED

The Power LED connection is located on pins 15 and 16 of JF1. Refer to the table on the right for pin definitions.

Power LED Pin Definitions (JF1)	
Pin#	Definition
15	Vcc
16	Control

## HDD LED

The HDD (IDE Hard Disk Drive) LED connection is located on pins 13 and 14 of JF1. Attach the IDE hard drive LED cable to display disk activity. Refer to the table on the right for pin definitions.

HDD LED Pin Definitions (JF1)	
Pin#	Definition
13	Vcc
14	HD Active

## NIC1 LED

The NIC1 (Network Interface Controller) LED connection is located on pins 11 and 12 of JF1. Attach the NIC1 LED cable to display network activity. Refer to the table on the right for pin definitions.

NIC1 LED Pin Definitions (JF1)	
Pin#	Definition
11	Vcc
12	NIC1 Active

## NIC2 LED

The NIC2 (Network Interface Controller) LED connection is located on pins 9 and 10 of JF1. Attach the NIC2 LED cable to display network activity. Refer to the table on the right for pin definitions.

NIC2 LED Pin Definitions (JF1)	
Pin#	Definition
9	Vcc
10	NIC2 Active

## Overheat/Fan Fail LED

Connect an LED to the OH connection on pins 7 and 8 of JF1 to provide advanced warning of chassis overheating. Refer to the table on the right for pin definitions and status indicators.

OH/Fan Fail LED Pin Definitions (JF1)		OH/Fan Fail LED Status	
Pin#	Definition	State	Indication
7	Vcc	Solid	Overheat
8	Control	Blinking	Fan fail

## Power Fail LED

The Power Fail LED connection is located on pins 5 and 6 of JF1. Refer to the table on the right for pin definitions. This feature is only available for systems with redundant power supplies.

Power Fail LED Pin Definitions (JF1)	
Pin#	Definition
5	Vcc
6	Control

## Reset Button

The Reset Button connection is located on pins 3 and 4 of JF1. Attach it to the hardware reset switch on the computer case. Refer to the table on the right for pin definitions.

Reset Button Pin Definitions (JF1)	
Pin#	Definition
3	Reset
4	Ground

## Power Button

The Power Button connection is located on pins 1 and 2 of JF1. Momentarily contacting both pins will power on/off the system. This button can also be configured to function as a suspend button (see the Power Button Mode setting in BIOS). To turn off the power when set to suspend mode, depress the button for at least 4 seconds. Refer to the table on the right for pin definitions.

Power Button Pin Definitions (JF1)	
Pin#	Definition
1	PW_ON
2	Ground

## Universal Serial Bus Ports (USB0/1)

Two Universal Serial Bus ports (USB2.0) are located beside the keyboard/mouse ports. See the table on the right for pin definitions.

Universal Serial Bus Ports Pin Definitions (USB0/1)			
USB0		USB1	
Pin #	Definition	Pin #	Definition
1	+5V	1	+5V
2	PO-	2	PO-
3	PO+	3	PO+
4	Ground	4	Ground

## USB Headers

Two additional USB2.0 headers (USB2/3) are included on the serverboard. These may be connected to provide front side access. A USB cable (not included) is needed for the connection. See the table on the right for pin definitions.

Universal Serial Bus Headers Pin Definitions (USB2/3)			
USB2		USB3	
Pin #	Definition	Pin #	Definition
1	+5V	1	+5V
2	PO-	2	PO-
3	PO+	3	PO+
4	Ground	4	Ground
5	Key	5	No connection

## Serial Ports

The COM1 serial port is located under the parallel port and the COM2 header is located between PCI slots #2 and #3. Refer to the table on the right for pin definitions.

Serial Port Pin Definitions (COM1/COM2)			
Pin #	Definition	Pin #	Definition
1	DCD	6	DSR
2	RXD	7	RTS
3	TXD	8	CTS
4	DTR	9	RI
5	Ground	10	NC

**Note:** NC indicates no connection.

## Fan Headers

The serverboard has nine fan headers, which are designated FAN1 through FAN9. Fans speed may be set to full or variable speed with a BIOS setting. See the table on the right for pin definitions.

Fan Header Pin Definitions (FAN1-9)	
Pin#	Definition
1	Ground (Black)
2	+12V/9V (Red)
3	Tachometer

**Note:** when using active heatsinks, FAN4 is for CPU1, FAN3 is for CPU2, FAN7 is for CPU3 and FAN8 is for CPU4.

**Note:** Fan speed may controlled by a BIOS setting to change with system temperature. As a result, pin 2 may be either 12V or 9 V. See page 7-14.

## JLAN1/2 (Ethernet Ports)

Two Gigabit Ethernet ports (designated JLAN1 and JLAN2) are located beside the COM2 port. These Ethernet ports accept RJ45 type cables.



## Power LED/Keylock/Speaker

On the JF2 header, pins 2, 4 and 6 are for the power LED, pins 8 and 10 are for the keylock and pins 1, 3, 5 and 7 are for the speaker (there is no pin 9). See the tables on the right for pin definitions and below right for pin locations

**Note:** The speaker connector pins are for use with an external speaker. If you wish to use the onboard speaker, you should close pins 5 and 7 with a jumper.

Speaker Connector Pin Definitions (JF2)	
Pin#	Definition
1	Red wire, speaker data
3	NC
5	Buzzer signal
7	Speaker data

Pwr LED/Keylock Connector Pin Definitions (JF2)	
Pin#	Definition
2	+Vcc
4	-Vcc
6	-Vcc
8	Keylock
10	Ground

JF2 Pinout

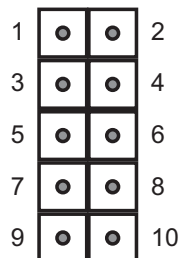

## ATX PS/2 Keyboard and PS/2 Mouse Ports

The ATX PS/2 keyboard and the PS/2 mouse ports are located at J3. The mouse is the top (green) port. See the table on the right for pin definitions.

PS/2 Keyboard and Mouse Port Pin Definitions (J3)	
Pin#	Definition
1	Data
2	NC
3	Ground
4	VCC
5	Clock
6	NC

## Chassis Intrusion

A Chassis Intrusion header is located at JL1. Attach the appropriate cable to inform you of a chassis intrusion.

Chassis Intrusion Pin Definitions (JL1)	
Pin#	Definition
1	Intrusion Input
2	Ground

## Wake-On-LAN

The Wake-On-LAN header is designated JWOL. See the table on the right for pin definitions. You must have a LAN card with a Wake-On-LAN connector and cable to use the Wake-On-LAN feature.

Wake-On-LAN Pin Definitions (JWOL)	
Pin#	Definition
1	+5V Standby
2	Ground
3	Wake-up

## Wake-On-Ring

The Wake-On-Ring header is designated JWOR. This function allows your computer to receive and "wake-up" by an incoming call to the modem when in suspend state. See the table on the right for pin definitions. You must have a Wake-On-Ring card and cable to use this feature.

Wake-On-Ring Pin Definitions (JWOR)	
Pin#	Definition
1	Ground (Black)
2	Wake-up

## Overheat LED

Connect an LED to the JOH header to provide warning of chassis overheating. See the table on the right for pin definitions.

Overheat LED Pin Definitions (JOH)	
Pin#	Definition
1	+3.3V
2	OH Active

## 3rd Power Supply Alarm Reset Header

Connect a cable from your power supply to JAR to provide you with warning of a power supply failure. The warning signal is passed through the PWR\_LED pin to indicate a power failure. See the table on the right for pin definitions.

3rd Power Supply Alarm Reset Header Pin Definitions (JAR)	
Pin#	Definition
1	P/S 1 Fail Signal
2	P/S 2 Fail Signal
3	P/S 3 Fail Signal
4	Reset (from MB)

**Note:** This feature is only available when using redundant power supplies.

### I<sup>2</sup>C Header for Power Supply

The I<sup>2</sup>C header at J16 may be used to monitor the power supply. See the table on the right for pin definitions.

I <sup>2</sup> C Header for Power Supply Pin Definitions (J16)	
Pin#	Definition
1	Clock
2	Data
3	PWR Fail
4	Gnd
5	+3.3V

### SMBus Header

The JSMB header is provided for System Management Bus connection. See the table on the right for pin definitions.

SMBus Header Pin Definitions (JSMB)	
Pin#	Definition
1	Data
2	Gnd
3	Clock
4	NC

### Additional Fan Headers

Four additional fan headers, designated nFAN1 through nFAN4, are included on the serverboard. nFAN1 and nFAN2 should be connected to the heatsinks on the 2200 and 8132 (chipset) chips and nFAN3 and nFAN4 should be connected to the heatsinks that are used with the air shroud. See the table on the right for pin definitions.

Additional Fan Header Pin Definitions (nFAN1-4)	
Pin#	Definition
1	12V
2	Ground

### Compact Flash Power Headers

JWF1 and JWF2 are power headers for compact flash devices, which can be connected to the IDE ports. See the table on the right for pin definitions.

DOC Power Header Pin Definitions (JWF1)	
Pin#	Definition
1	+5V
2	Ground
3	Signal

## 5-10 Jumper Settings

### Explanation of Jumpers

To modify the operation of the serverboard, jumpers can be used to choose between optional settings. Jumpers create shorts between two pins to change the function of the connector. Pin 1 is identified with a square solder pad on the printed circuit board. See the diagram at right for an example of jumping pins 1 and 2. Refer to the serverboard layout page for jumper locations.

**Note 1:** On two-pin jumpers, "Closed" means the jumper is on and "Open" means the jumper is off the pins.

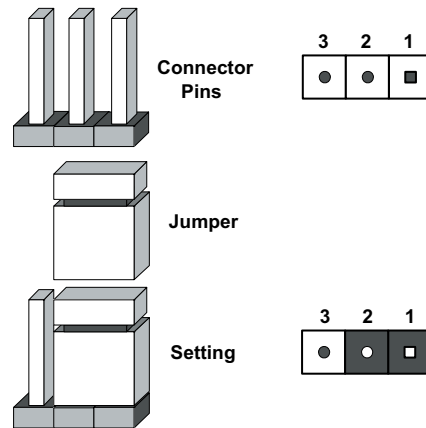

### CMOS Clear

JBT1 is used to clear CMOS and will also clear any passwords. Instead of pins, this jumper consists of contact pads to prevent accidentally clearing the contents of CMOS.

To clear CMOS,

- 1) First power down the system and unplug the power cord(s).
- 2) With the power disconnected, short the CMOS pads with a metal object such as a small screwdriver for at least four seconds.
- 3) Remove the screwdriver (or shorting device).
- 4) Reconnect the power cord(s) and power on the system.

#### Notes:

Do not use the PW\_ON connector to clear CMOS.

The onboard battery does not need to be removed when clearing CMOS, however you must short JBT1 for at least four seconds.



JBT1 contact pads

### SCSI Controller Enable/ Disable (4040C-8R only)

Jumper JPA1 is used to enable or disable the Adaptec AIC-7902W SCSI controller. The default setting is on pins 1-2 to enable SCSI. See the table on right for jumper settings.

SCSI Enable/Disable Jumper Settings (JPA1)	
Both Jumpers	Definition
Pins 1-2	Enabled
Pins 2-3	Disabled

### SCSI Termination Enable/ Disable (4040C-8R only)

Jumpers JPA2 and JPA3 are used to enable or disable termination for SCSI channels A and B, respectively. The default setting is open to enable termination. See the table on right for jumper settings.

SCSI Term. Enable/Disable Jumper Settings (JPA2/JPA3)	
Jumper Setting	Definition
Open	Enabled
Closed	Disabled

**Note:** In order for the SCSI drives to function properly, please do not change the default setting (enabled) set by the manufacturer.)

### 3rd Power Supply Fail Signal Enable/Disable

The system can notify you in the event of a power supply failure. This feature assumes that three redundant power supply units are installed in the chassis. If you only have one or two power supplies installed, you should disable the function with the J3P header to prevent false alarms. See the table on the right for jumper settings.

3rd Power Supply Fail Signal Jumper Settings (J3P)	
Jumper Setting	Definition
Open	Disabled
Closed	Enabled

## Watch Dog Enable/Disable

JWD controls the Watch Dog function. Watch Dog is a system monitor that can reboot the system when a software application hangs. Pins 1-2 will cause WD to reset the system if an application has frozen. Pins 2-3 will disable the Watch Dog feature. See the table on the right for jumper settings. Watch Dog must also be enabled in BIOS (setting located in the Power Menu).

Watch Dog Jumper Settings (JWD)	
Jumper Setting	Definition
Pins 1-2	Reset
Pins 2-3	Disabled

**Note:** When enabled, the user needs to write their own application software in order to disable the Watch Dog timer.

## JLAN Enable/Disable

Change the setting of jumper JPL1 to enable or disable the JLAN1 and JLAN2 Gb Ethernet ports. See the table on the right for jumper settings. The default setting is enabled.

JLAN1/2 Enable/Disable Jumper Settings (JPL1)	
Jumper Setting	Definition
Pins 1-2	Enabled
Pins 2-3	Disabled

## VGA Enable/Disable

JPG1 allows you to enable or disable the VGA port. The default position is on pins 1 and 2 to enable VGA. See the table on the right for jumper settings.

VGA Enable/Disable Jumper Settings (JPG1)	
Jumper Setting	Definition
Pins 1-2	Enabled
Pins 2-3	Disabled

---

## 5-11 Onboard Indicators

### JLAN1/JLAN2 LEDs

The Ethernet ports (located beside the VGA port) have two LEDs. On each Gb LAN port, one LED indicates activity when blinking while the other LED may be green, amber or off to indicate the speed of the connection. See the table on the right for the functions associated with the connection speed LED.

JLAN LED (Connection Speed Indicator)	
LED Color	Definition
Off	10 MHz
Green	100 MHz
Amber	1 GHz

## 5-12 Floppy, IDE, Parallel Port, SCSI and SATA Drive Connections

Use the following information to connect the floppy and hard disk drive cables.

- The floppy disk drive cable has seven twisted wires.
- A red mark on a wire typically designates the location of pin 1.
- A single floppy disk drive ribbon cable has 34 wires and two connectors to provide for two floppy disk drives. The connector with twisted wires always connects to drive A, and the connector that does not have twisted wires always connects to drive B.
- The 80-wire ATA133 IDE hard disk drive cable that came with your system has two connectors to support two drives. This special cable should be used to take advantage of the speed this new technology offers. The blue connector connects to the onboard IDE connector interface and the other connector(s) to your hard drive(s). Consult the documentation that came with your disk drive for details on actual jumper locations and settings for the hard disk drive.

### Floppy Connector

The floppy connector is located beside the IDE#1 connector. See the table on the right for pin definitions.

Floppy Drive Connector Pin Definitions (Floppy)			
Pin#	Definition	Pin #	Definition
1	GND	2	FDHDIN
3	GND	4	Reserved
5	Key	6	FDEDIN
7	GND	8	Index-
9	GND	10	Motor Enable
11	GND	12	Drive Select B-
13	GND	14	Drive Select A-
15	GND	16	Motor Enable
17	GND	18	DIR-
19	GND	20	STEP-
21	GND	22	Write Data-
23	GND	24	Write Gate-
25	GND	26	Track 00-
27	GND	28	Write Protect-
29	GND	30	Read Data-
31	GND	32	Side 1 Select-
33	GND	34	Diskette

## IDE Connectors

There are no jumpers to configure the onboard IDE#1 and #2 connectors. See the table on the right for pin definitions.

IDE Drive Connectors Pin Definitions (IDE#1/IDE#2)			
Pin#	Definition	Pin #	Definition
1	Reset IDE	2	Ground
3	Host Data 7	4	Host Data 8
5	Host Data 6	6	Host Data 9
7	Host Data 5	8	Host Data 10
9	Host Data 4	10	Host Data 11
11	Host Data 3	12	Host Data 12
13	Host Data 2	14	Host Data 13
15	Host Data 1	16	Host Data 14
17	Host Data 0	18	Host Data 15
19	Ground	20	Key
21	DRQ3	22	Ground
23	I/O Write	24	Ground
25	I/O Read	26	Ground
27	IOCHRDY	28	BALE
29	DACK3	30	Ground
31	IRQ14	32	IOCS16
33	Addr1	34	Ground
35	Addr0	36	Addr2
37	Chip Select 0	38	Chip Select 1
39	Activity	40	Ground

## Parallel Port Connector

The parallel (printer) port is located on the I/O backplane. See the table on the right for pin definitions.

Parallel Port Connector Pin Definitions			
Pin#	Definition	Pin #	Definition
1	Strobe-	2	Auto Feed-
3	Data Bit 0	4	Error-
5	Data Bit 1	6	Init-
7	Data Bit 2	8	SLCT IN-
9	Data Bit 3	10	GND
11	Data Bit 4	12	GND
13	Data Bit 5	14	GND
15	Data Bit 6	16	GND
17	Data Bit 7	18	GND
19	ACK	20	GND
21	BUSY	22	Write Data
23	PE	24	Write Gate
25	SLCT	26	NC

## SATA Ports

There are no jumpers to configure the SATA ports, which are designated SATA0-SATA3. See the table on the right for pin definitions.

SATA Drive Ports Pin Definitions (SATA0-SATA3)	
Pin #	Definition
1	Ground
2	TXP
3	TXN
4	Ground
5	RXN
6	RXP
7	Ground

## SCSI Connectors (4040C-8R only)

Refer to the table at right for pin definitions for the Ultra320 SCSI connectors located at JA1 and JB1.

Ultra320 SCSI Drive Connectors Pin Definitions (JA1/JB1)			
Pin#	Definition	Pin #	Definition
1	+DB (12)	35	-DB (12)
2	+DB (13)	36	-DB (13)
3	+DB (14)	37	-DB (14)
4	+DB (15)	38	-DB (15)
5	+DB (P1)	39	-DB (P1)
6	+DB (0)	40	-DB (0)
7	+DB (1)	41	-DB (1)
8	+DB (2)	42	-DB (2)
9	+DB (3)	43	-DB (3)
10	+DB (4)	44	-DB (4)
11	+DB (5)	45	-DB (5)
12	+DB (6)	46	-DB (6)
13	+DB (7)	47	-DB (7)
14	+DB (P)	48	-DB (P)
15	Ground	49	Ground
16	DIFFSENS	50	Ground
17	TERMPWR	51	TERMPWR
18	TERMPWR	52	TERMPWR
19	Reserved	53	Reserved
20	Ground	54	Ground
21	+ATN	55	-ATN
22	Ground	56	Ground
23	+BSY	57	-BSY
24	+ACK	58	-ACK
25	+RST	59	-RST
26	+MSG	60	-MSG
27	+SEL	61	-SEL
28	+C/D	62	-C/D
29	+REQ	63	-REQ
30	+I/O	64	-I/O
31	+DB (8)	65	-DB (8)
32	+DB (9)	66	-DB (9)
33	+DB (10)	67	-DB (10)
34	+DB (11)	68	-DB (11)

## 5-13 Enabling SATA RAID

### Serial ATA (SATA)

Serial ATA (SATA) is a physical storage interface that employs a single cable with a minimum of four wires to create a point-to-point connection between devices. This connection is a serial link that supports a SATA transfer rate from 150 MBps. The serial cables used in SATA are thinner than the traditional cables used in Parallel ATA (PATA) and can extend up to one meter in length, compared to only 40 cm for PATA cables. Overall, SATA provides better functionality than PATA.

### Installing the OS/SATA Driver

Before installing the OS (operating system) and SATA RAID driver, you must decide if you wish to have the operating system installed as part of a bootable RAID array or installed to a separate non-RAID hard drive. If on a separate drive, you may install the driver either during or after the OS installation. If you wish to have the OS on a SATA RAID array, you must follow the procedure below and install the driver during the OS installation.

**Note:** the SATA RAID driver is supported by Windows 2000 and XP only.

### Building a Driver Diskette

You must first build a driver diskette from the CD-ROM that was included with the system. (You will have to create this disk on a computer that is already running and with the OS installed.) Insert the CD into your CD-ROM drive and start the system. A display as shown in Figure 5-6 will appear. Click on the icon labeled "Build Driver Diskettes and Manuals" and follow the instructions to create a floppy disk with the driver on it. Once it's been created, remove the floppy and insert the installation CD for the Windows Operating System you wish to install into the CD-ROM drive of the new system you are about to configure.

### Enabling SATA RAID in the BIOS

Before installing the Windows Operating System, you must change some settings in BIOS. Boot up the system and hit the <Del> key to enter the BIOS Setup Utility. After the Setup Utility loads,

1. Use the arrow keys to move to the Exit menu. Scroll down with the arrow keys to the "Load Optimal Defaults setting and press <Enter>. Select "OK" to confirm, then <Enter> to load the default settings.

2. Use the arrow keys to move to the "Advanced" menu, then scroll down to "IDE Configuration" and press the <Enter> key. Once in the IDE Configuration submenu, scroll down to "Configuration nVidia RAID ROM" and press <Enter> to access that submenu. Highlight the setting "RAID Option ROM" and press enter, change the setting to Enabled and hit <Enter> again. Two new settings should now be displayed: "Master SATA as RAID" and "Slave SATA as RAID". Enable both of these settings, whether you think you will use them both or not.
3. Hit the <Esc> key twice and scroll to the Exit menu. Select "Save Changes and Exit" and hit <enter>, then hit <Enter> again to verify.
4. After exiting the BIOS Setup Utility, the system will reboot. When prompted during the startup, press the <F10> key when prompted to run the nVidia RAID Utility program.

### Using the nVidia RAID Utility

The nVidia RAID Utility program is where you can define the drives you want to include in the RAID array and the mode and type of RAID. Two main windows are shown in the utility. The "Free Disks" window on the left will list all available drives. Use the arrow keys to select and move drives to the window on the right, which lists all drives that are to become part of the RAID array.

Once you have finished selecting the drives and type of RAID you wish to use for your RAID array, press the <F7> key. You will be prompted to verify your choice; if you want to continue with your choices, select "Yes". Note that selecting "Yes" will clear all previous data from the drives you selected to be a part of the array. You are then given the choice of making the RAID array bootable by pressing the the <B> key. After you have finished, press the <Ctrl> and <X> keys simultaneously.

### Installing the OS and Drivers

With the Windows OS installation CD in the CD-ROM drive, restart the system. When you see the prompt, hit the <F6> key to enter Windows setup. Eventually a blue screen will appear with a message that begins "Windows could not determine the type of one or more storage devices . . ." When you see the screen, hit the <S> key to "Specify Additional Device", then insert the driver diskette you just created into the floppy drive. Highlight "Manufacturer Supplied Hardware Support Disk" and hit the <Enter> key. Highlight the first "nVidia RAID" driver shown and press the <Enter> key to install it. Soon a similar blue screen will appear again. Again hit the <S> key, then highlight the second item, "nForce Storage Controller" and press the <Enter> key, then <Enter> again to continue with the Windows setup.

Figure 5-6. Driver Installation Screen Shot

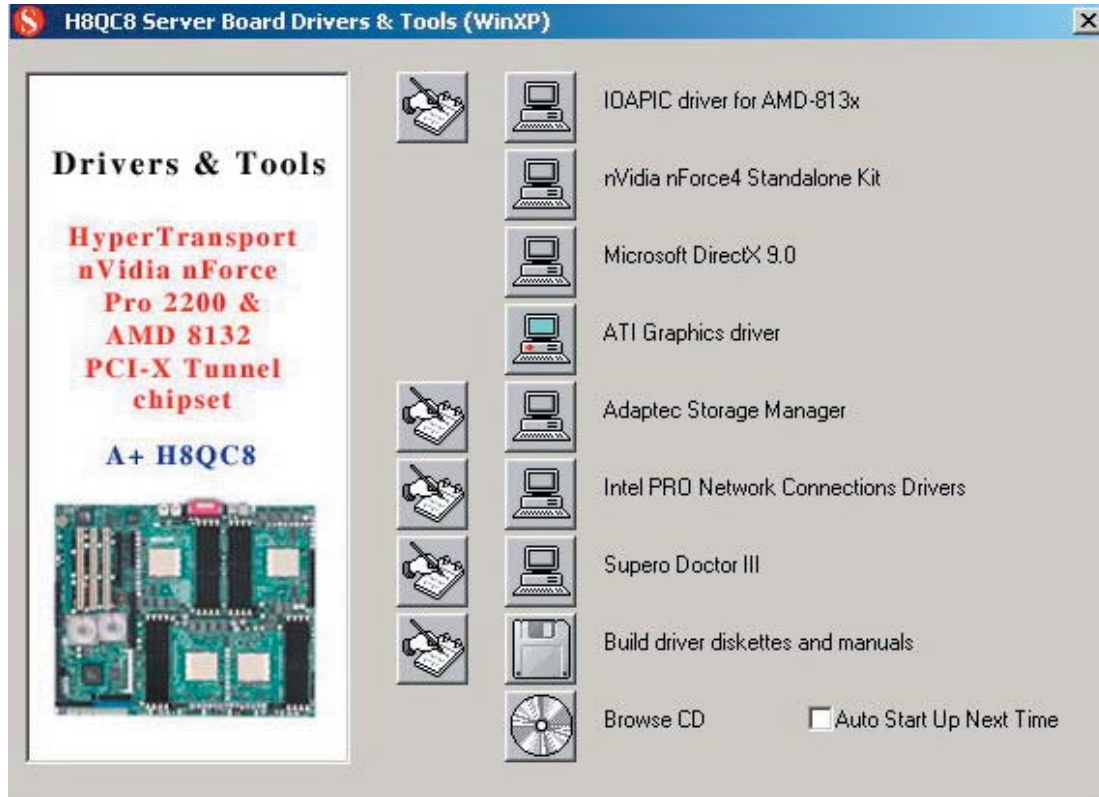

## Chapter 6

### Advanced Chassis Setup

This chapter covers the steps required to install components and perform simple maintenance on the SC748TQ-R1000/SC748S-R1000 chassis. Following the component installation steps in the order given will eliminate most common problems. If some steps are unnecessary, skip ahead to the step that follows. Refer to Chapter 2 for instructions on installing the system as a 4U rackmount.

#### Tools Required

The only tool you will need is a Philips screwdriver.

### 6-1 Static-Sensitive Devices

Static electrical discharge can damage electronic components. To prevent damage to any printed circuit boards (PCBs), it is important to handle them very carefully. The following measures are generally sufficient to protect your equipment from static discharge.

#### Precautions

- Use a grounded wrist strap designed to prevent static discharge.
- Touch a grounded metal object before removing any board from its antistatic bag.
- Handle a board by its edges only; do not touch its components, peripheral chips, memory modules or gold contacts.
- When handling chips or modules, avoid touching their pins.
- Put the serverboard, add-on cards and peripherals back into their antistatic bags when not in use.
- For grounding purposes, make sure your computer chassis provides excellent conductivity between the power supply, the case, the mounting fasteners and the serverboard.

#### Unpacking

The serverboard is shipped in antistatic packaging. When unpacking the board, make sure the person handling it is static protected.

---



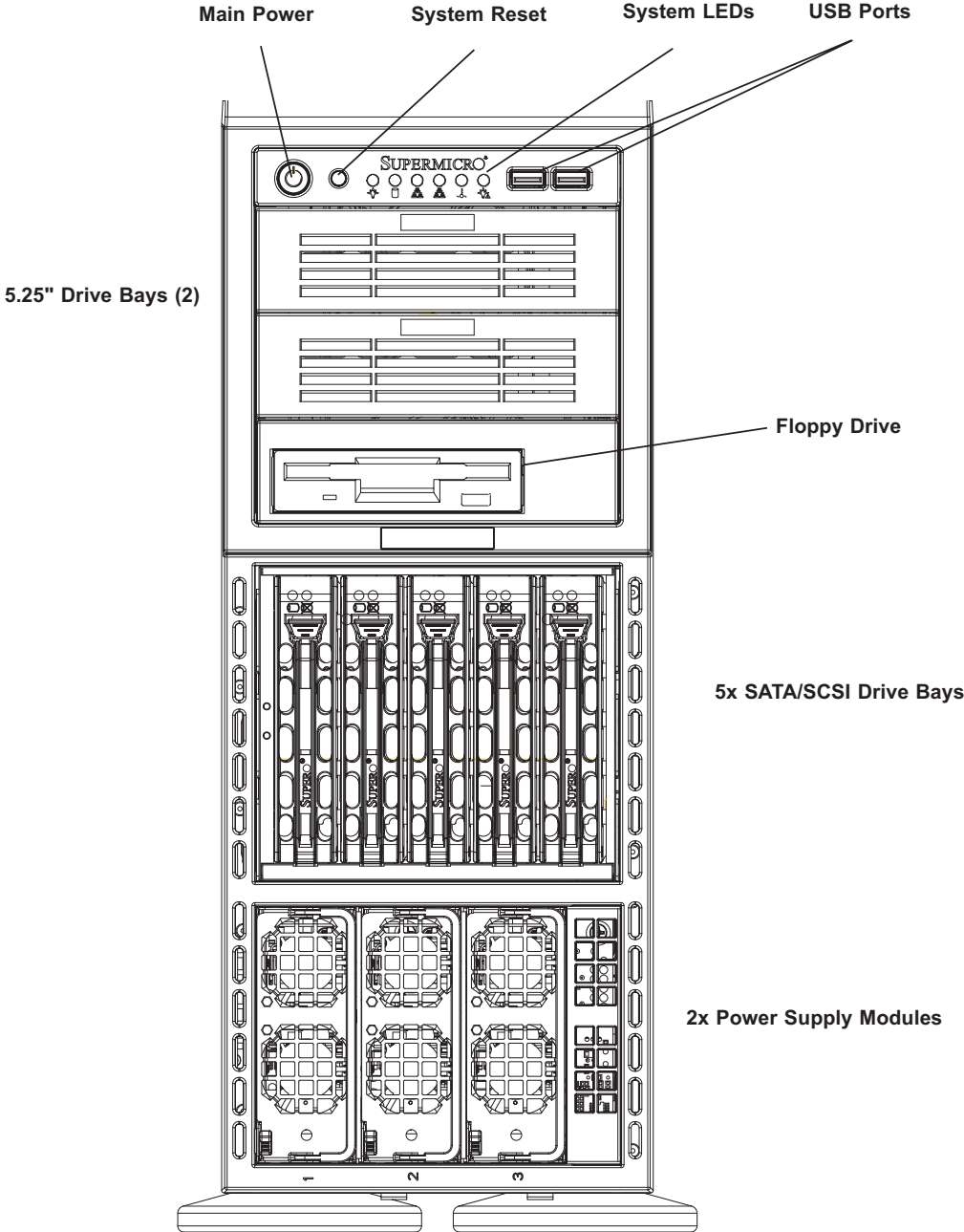



Figure 6-1. Chassis Front View



## 6-2 Control Panel

The front control panel must be connected to the JF1 connector on the serverboard to provide you with system status and alarm indications. A ribbon cable has bundled these wires together to simplify this connection. Connect the cable from JF1 on the serverboard (making sure the red wire plugs into pin 1) to the appropriate connector on the front control panel PCB (printed circuit board). Pull all excess cabling over to the control panel side of the chassis. The LEDs on the control panel inform you of system status - see Figure 6-2 for details. See Chapter 5 for details on JF1.

**Figure 6-2. Front Control Panel LEDs**

<b>Power</b>		Indicates power is being supplied to the system.
<b>HDD</b>		Indicates IDE device and hard drive activity. On the SC748TQ-R1000/SC748S-R1000, this LED indicates SATA/SCSI hard drive activity when flashing.
<b>NIC1</b>		Indicates network activity on LAN port 1.
<b>NIC2</b>		Indicates network activity on LAN port 2
<b>Overheat/Fan Fail</b>		When this LED flashes, it indicates a fan failure. When on continuously it indicates an overheat condition (see Chapter 3 for details).
<b>Power Fail</b>		Indicates a power supply failure.

## 6-3 System Fans

Three 9-cm chassis cooling fans (located in the center of the chassis) provide cooling airflow while three 8-cm exhaust fans expel hot air from the chassis. The fans should all be connected to headers on the serverboard (see Chapter 5). Each power supply module also has a cooling fan.

### Fan Failure

Under normal operation all chassis fans, exhaust fans and the power supply fans run continuously. The chassis fans are hot-swappable and can be replaced without powering down the system.

### Replacing Chassis Fans

#### 1. Identifying the failed fan

To locate and replace a failed chassis fan, begin by removing the top/left chassis cover (see Chapter 2 for details on removing the cover). Locate the fan that has stopped working.

#### 2. Removing a hot-plug fan housing

Depress the locking tab on the failed fan: on a chassis fan, push the tab on the side of the housing inward, on the exhaust fan push down on the colored tab. With the tab depressed, pull the unit straight out (see Figure 6-3). The wiring for these fans has been designed to detach automatically.

#### 3. Installing a new system fan

Replace the failed fan with an identical one (available from Supermicro). Install it in the same position and orientation as the one you removed; it should click into place when fully inserted. Check that the fan is working then replace the top/left side chassis panel.

### Removing the air shroud

Under most circumstances you will not need to remove the air shroud to perform any service on the system. However, if you wish to temporarily remove it (the air shroud should always be in place when the system is operating), please follow this procedure. Begin by depressing the tabs at the front and rear of the shroud to unlock it, then lift it up and out of the chassis (see Figure 6-4). To reinstall, simply position the air shroud in its proper place and push it in until you hear it click.

Figure 6-3. Removing a Chassis Fan

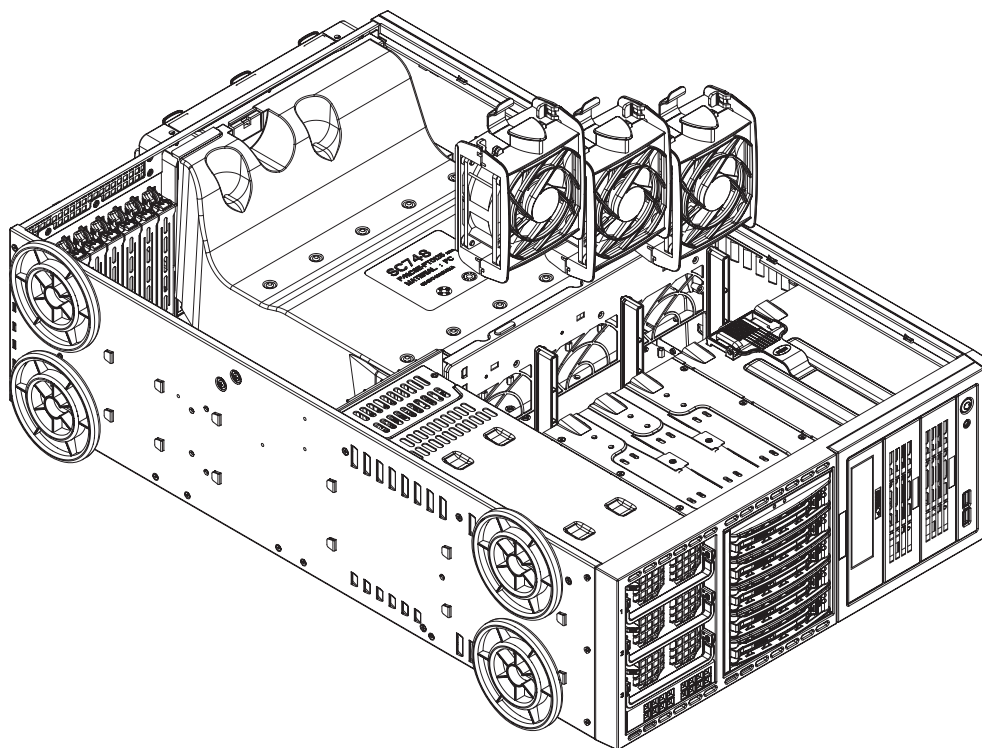
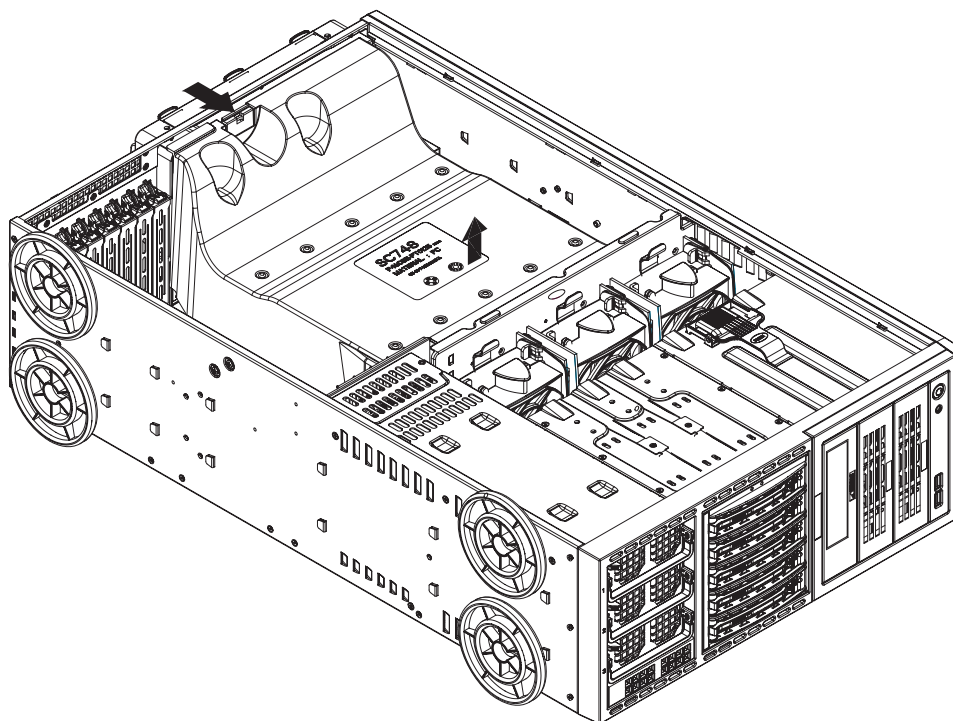

Figure 6-4. Removing the Air Shroud



## 6-4 Drive Bay Installation

### SCSI and SATA Drives

A total of eight SCSI or six SATA drives may be housed in the SC748TQ-R1000/SC748S-R1000 chassis. For SATA, the drive IDs are preconfigured as 0 through 3 in order from bottom to top (or from left to right if rackmounted). For SCSI, the drive IDs are preconfigured as 0 through 3 (channel A) in order from bottom to top (or from left to right if rackmounted).



**Regardless of how many SATA/SCSI drives are installed, all drive carriers must remain in the drive bays to promote proper airflow.**

#### 1. Installing/removing hot-swap SATA/SCSI drives

The SATA/SCSI drive carriers are all easily accessible at the front of the chassis. These drives are hot-swappable, meaning they can be removed and installed without powering down the system. To remove a carrier, first open the front bezel then push the release button located beside the drive LEDs. Swing the handle fully out and then use it to pull the unit straight out.

**Note:** Your operating system must have RAID support to enable the hot-swap capability of the SATA/SCSI drives.

#### 2. Mounting a SATA/SCSI drive in a drive carrier

The SATA/SCSI drives are mounted in drive carriers to simplify their installation and removal from the chassis. These carriers also work to promote proper airflow for the system. For this reason, even carriers without SATA/SCSI drives must remain in the server. If you need to add a new SATA/SCSI drive, insert the drive into the carrier with the printed circuit board side facing down so that the mounting holes align with those in the carrier. Secure the drive to the carrier with four screws (see Figure 6-5).

#### 3. SATA/SCSI backplane

The SATA/SCSI drives plug into a SATA/SCSI backplane. SCSI: Two data cables (CBL-037L-U320 and CBL-0063L) need to be connected from the serverboard to the appropriate connectors on the backplane to provide dual-channel operation for the SCSI drives. There are also two power connectors on the backplane - both

Figure 6-4. Removing a SCSI Drive Carrier

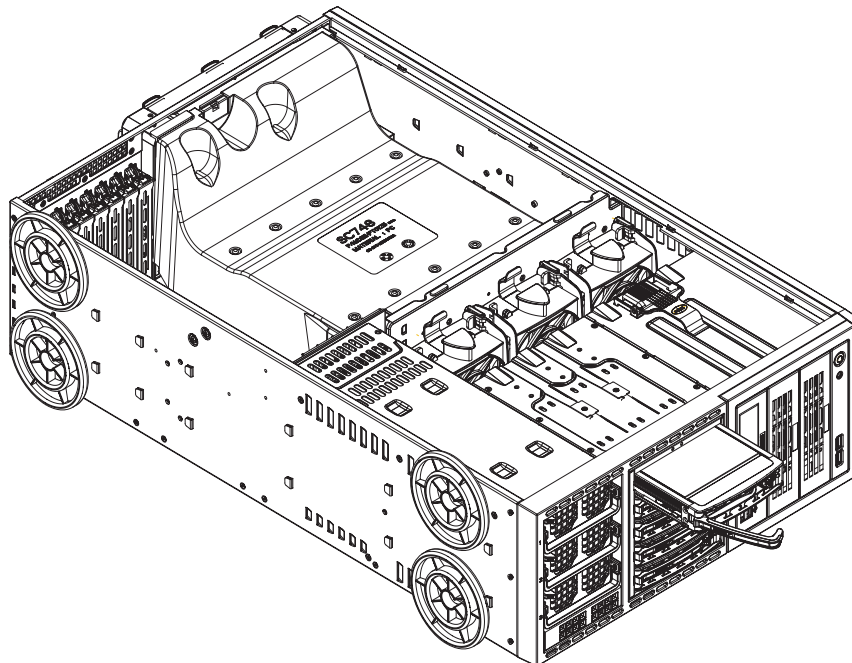
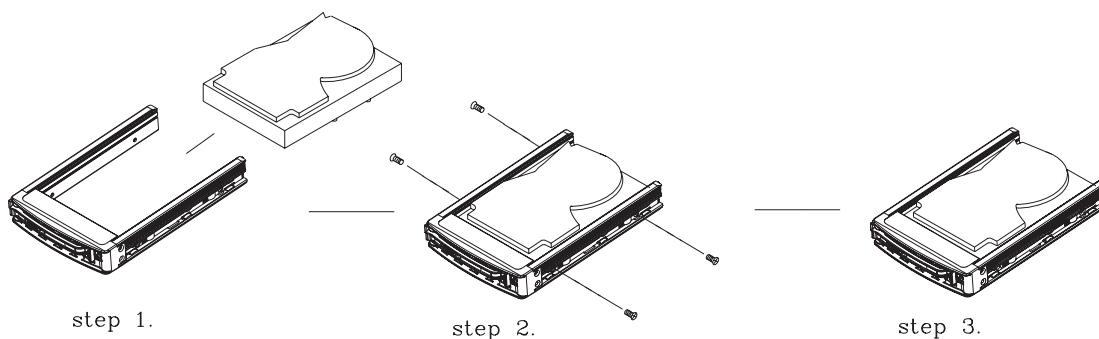

Figure 6-5. Mounting a SCSI Drive in a Carrier



**Important! Use extreme caution when working around the SATA/SCSI backplane. Do not touch the backplane with any metal objects and make sure no ribbon cables touch the backplane or obstruct the airflow holes.**

should be connected. **SATA:** Four data cables (CBL-061L) and two SATA LED cables (CBL-0157L) need to be connected from the serverboard to the appropriate connectors on the backplane to support the SATA drives. You cannot cascade the SATA/SCSI backplane.

## Installing Components in the 5.25" Drive Bays

### 1. Drive bay configuration

The 4040C-TR/4040C-8R has three 5.25" drive bays. Components such as an extra floppy drive, IDE hard drives or DVD/CD-ROM drives can be installed into these 5.25" drive bays.

### 2. Mounting components in the drive bays

First power down the system and then remove the top/left chassis cover to access the drive components. With the cover off, remove the two or four screws that secure the drive carrier to the chassis (one side only) then push the entire empty drive carrier out from the back.

Adding a DVD/CD-ROM drive: remove the guide plates (one on each side) from the empty drive carrier and screw them into both sides of the DVD/CD-ROM drive using the holes provided. Then slide the DVD/CD-ROM into the bay and secure it to the chassis with the drive carrier screws you first removed. Attach the power and data cables to the drive. Replace the top/left chassis cover before restoring power to the system.

Adding an IDE or floppy drive: to add one of these drives, install it into one of the removed empty drive carriers with the printed circuit board side toward the carrier so that the drive's mounting holes align with those in the carrier. Secure the drive to the carrier with four screws then slide the assembly into the bay and secure it to the chassis with the drive carrier screws you first removed. Attach the power and data cables to the drive. Replace the top/left chassis cover before restoring power to the system.

**Note:** A red wire typically designates the location of pin 1. You should keep the drive carriers inserted in any unused drive bays to reduce EMI and noise and to facilitate the airflow inside the chassis.

**Figure 6-7. Adding a Component Without a Drive Carrier**

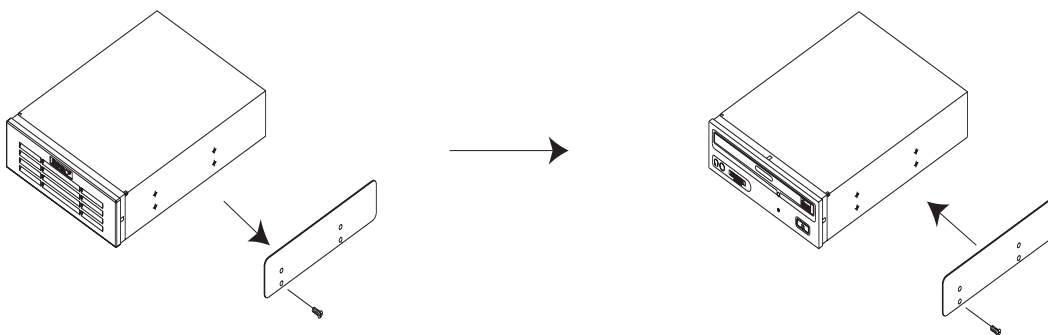

## 6-5 Power Supply

The SuperServer 4040C-TR/4040C-8R has a redundant 1000 watt power supply consisting of two power modules. Each power supply module has an auto-switching capability, which enables it to automatically sense and operate at a 100V - 240V input voltage.

### Power Supply Failure

If either of the two power supply modules fail, the other module will take the full load and allow the system to continue operation without interruption. The PWR Fail LED will illuminate and remain on until the failed unit has been replaced. Replacement units can be ordered directly from Supermicro (see contact information in the Preface). The hot-swap capability of the power supply modules allows you to replace the failed module without powering down the system.

### Removing/Replacing the Power Supply

You do not need to shut down the system to replace a power supply unit. The redundant feature will keep the system up and running while you replace the failed hot-swap unit. Replace with the same model - (see Appendix C).

#### 1. Removing the power supply

First unplug the power cord from the failed power supply unit. Then depress the locking tab on the power supply unit and pull the unit straight out by the handle. See Figure 6-8.

#### 2. Installing a new power supply

Replace the failed module with another power supply module (must be the exact same - refer to Appendix C for part number). Simply push the new power supply unit into the power bay until you hear a click. Finish by plugging the AC power cord back into the unit.

**Figure 6-8. Removing a Power Supply Module**

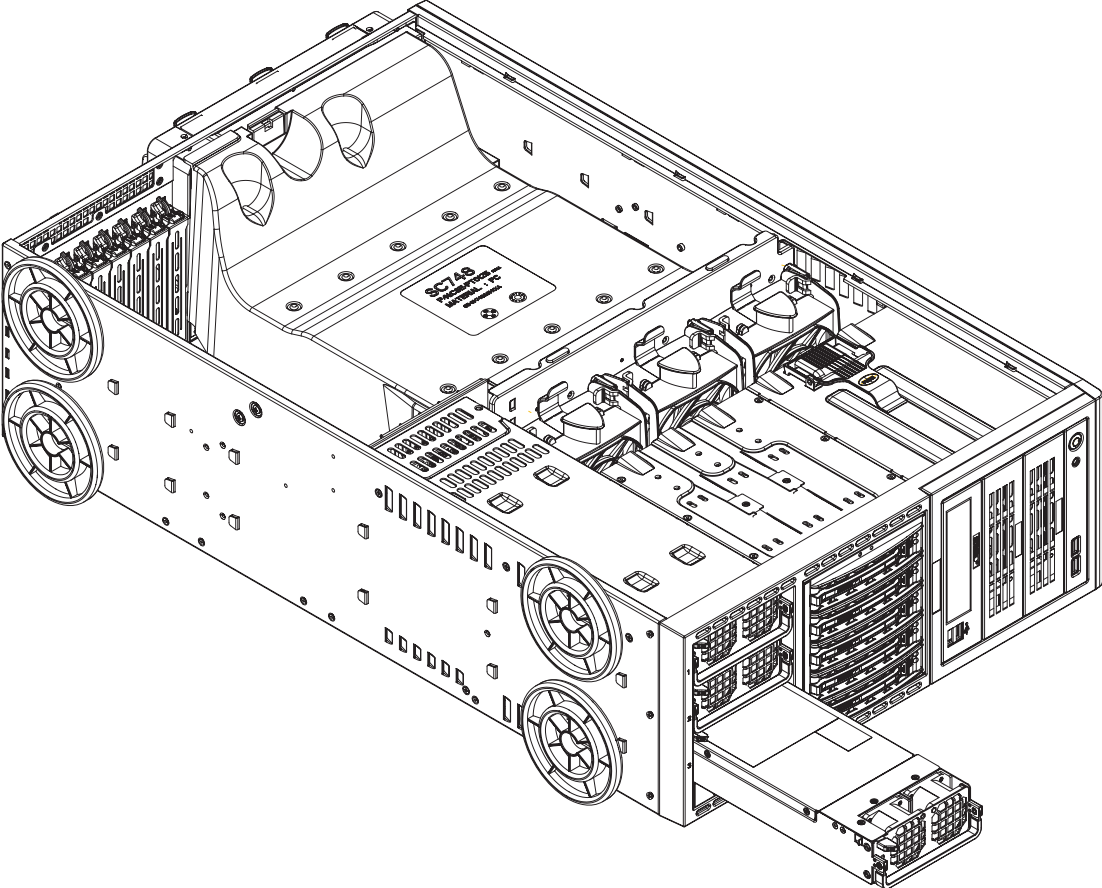

## Chapter 7

# BIOS

### 7-1 Introduction

This chapter describes the AMIBIOS™ Setup utility for the H8QCE/H8QC8. The AMI ROM BIOS is stored in a flash chip and can be easily upgraded using a floppy disk-based program.

**Note:** Due to periodic changes to the BIOS, some settings may have been added or deleted and might not yet be recorded in this manual. Please refer to the Manual Download area of our web site for any changes to BIOS that may not be reflected in this manual.

#### Starting the Setup Utility

To enter the BIOS Setup Utility, hit the <Delete> key while the system is booting-up. (In most cases, the <Delete> key is used to invoke the BIOS setup screen. There are a few cases when other keys are used, such as <F1>, <F2>, etc.) Each main BIOS menu option is described in this manual.

The Main BIOS screen has two main frames. The left frame displays all the options that can be configured. “Grayed-out” options cannot be configured. The right frame displays the key legend. Above the key legend is an area reserved for a text message. When an option is selected in the left frame, it is highlighted in white. Often a text message will accompany it. (Note that BIOS has default text messages built in. We retain the option to include, omit, or change any of these text messages.) Settings printed in **Bold** are the default values.

A " ►" indicates a submenu. Highlighting such an item and pressing the <Enter> key will open the list of settings within that submenu.

The BIOS setup utility uses a key-based navigation system called hot keys. Most of these hot keys (<F1>, <F10>, <Enter>, <ESC>, <Arrow> keys, etc.) can be used at any time during the setup navigation process.

## 7-2 Main Menu

When you first enter AMI BIOS Setup Utility, you will see the Main Menu screen. You can always return to the Main Menu by selecting the **Main** tab on the top of the screen with the arrow keys.

The Main Menu screen provides you with a system overview, which includes the version, built date and ID of the AMIBIOS, the type, speed and number of the processors in the system and the amount of memory installed in the system.

### System Time/System Date

You can edit this field to change the system time and date. Highlight *System Time* or *System Date* using the <Arrow> keys. Enter new values through the keyboard. Press the <Tab> key or the <Arrow> keys to move between fields. The date must be entered in DAY/MM/DD/YYYY format. The time is entered in HH:MM:SS format. Please note that time is in a 24-hour format. For example, 5:30 A.M. appears as 05:30:00 and 5:30 P.M. as 17:30:00.

## 7-3 Advanced Settings Menu

### ▶ CPU Configuration Sub-Menu

#### GART Error Reporting

This setting is used for testing only.

#### MTRR Mapping

This determines the method used for programming CPU MTRRs when 4 GB or more memory is present. The options are Continuous, which makes the PCI hole non-cacheable, and **Discrete**, which places the PCI hole below the 4 GB boundary.

### ▶ IDE Configuration

#### Onboard PCI IDE Controller

The following options are available to set the IDE controller status: Disabled will disable the controller. Primary will enable the primary IDE controller only. Secondary will enable the secondary IDE controller only. **Both** will enable both the primary and the secondary IDE controllers. The six controllers listed are for two dual-channel IDE and eight SATA devices.

## Primary/Secondary IDE Master/Slave

Highlight one of the items above and press <Enter> to access the submenu for that item.

### Type

Select the type of device connected to the system. The options are Not Installed, **Auto**, CDROM and ARMD.

### LBA/Large Mode

LBA (Logical Block Addressing) is a method of addressing data on a disk drive. In the LBA mode, the maximum drive capacity is 137 GB. For drive capacities of over 137 GB, your system must be equipped with 48-bit LBA mode addressing. If not, contact your manufacturer or install an ATA/133 IDE controller card that supports 48-bit LBA mode. The options are Disabled and **Auto**.

### Block (Multi-Sector Transfer)

Block mode boosts IDE drive performance by increasing the amount of data transferred. Only 512 bytes of data can be transferred per interrupt if block mode is not used. Block mode allows transfers of up to 64 KB per interrupt. Select "Disabled" to allow the data to be transferred from and to the device one sector at a time. Select "Auto" to allow the data transfer from and to the device occur multiple sectors at a time if the device supports it. The options are **Auto** and Disabled.

### PIO Mode

PIO (Programmable I/O) mode programs timing cycles between the IDE drive and the programmable IDE controller. As the PIO mode increases, the cycle time decreases. The options are **Auto**, 0, 1, 2, 3, and 4. Select Auto to allow AMI BIOS to auto detect the PIO mode. Use this value if the IDE disk drive support cannot be determined. Select 0 to allow AMI BIOS to use PIO mode 0. It has a data transfer rate of 3.3 MBs. Select 1 to allow AMI BIOS to use PIO mode 1. It has a data transfer rate of 5.2 MBs. Select 2 to allow AMI BIOS to use PIO mode 2. It has a data transfer rate of 8.3 MBs. Select 3 to allow AMI BIOS to use PIO mode 3. It has a data transfer rate of 11.1 MBs. Select 4 to allow AMI BIOS to use PIO mode 4. It has a data transfer rate of 16.6 MBs. This setting generally works with all hard disk drives manufactured after 1999. For other disk drives, such as IDE CD-ROM drives, check the specifications of the drive.

data transfer rate of 3.3 MBs. Select 1 to allow AMI BIOS to use PIO mode 1 for a data transfer rate of 5.2 MBs. Select 2 to allow AMI BIOS to use PIO mode 2 for a data transfer rate of 8.3 MBs. Select 3 to allow AMI BIOS to use PIO mode 3 for a data transfer rate of 11.1 MBs. Select 4 to allow AMI BIOS to use PIO mode 4 for a data transfer rate of 16.6 MBs. This setting generally works with all hard disk drives manufactured after 1999. For other disk drives, such as IDE CD-ROM drives, check the specifications of the drive.

### **DMA Mode**

Selects the DMA Mode. Options are SWDMA0, SWDMA1, SWDMA2, MWDMA0, MDWDMA1, MWDMA2, UDMA0, UDMA1, UDMA2, UDMA3, UDMA4 and UDMA5. (SWDMA=Single Word DMA, MWDMA=Multi Word DMA, UDMA=UltraDMA.)

### **S.M.A.R.T.**

Self-Monitoring Analysis and Reporting Technology (SMART) can help predict impending drive failures. Select "Auto" to allow BIOS to auto detect hard disk drive support. Select "Disabled" to prevent AMI BIOS from using the S.M.A.R.T. Select "Enabled" to allow AMI BIOS to use the S.M.A.R.T. to support hard drive disk. The options are Disabled, Enabled, and **Auto**.

### **32-Bit Data Transfer**

Select "Enabled" to activate the function of 32-Bit data transfer. Select "Disabled" to deactivate the function. The options are Enabled and **Disabled**.

### **SATA Port 0, SATA Port 1, SATA Port 2, SATA Port 3**

Displays the status of all SATA devices (automatically detected by BIOS during system start up).

### **Hard Disk Write Protect**

Select Enabled to enable the function of Hard Disk Write Protect to prevent data from being written to HDD. The options are Enabled or **Disabled**.

### **IDE Detect Time Out (Sec)**

This feature allows the user to set the time-out value for detecting ATA, ATA PI devices installed in the system. The options are 0 (sec), 5, 10, 15, 20, 25, 30 and **35**.

### **ATA(PI) 80Pin Cable Detection**

This setting allows AMI BIOS to auto-detect the 80-Pin ATA(PI) cable. The options are Host, Device and **Host & Device**.

### **SATA0 IDE Interface**

This setting is used to **Enable** or Disable the serial controller for SATA0.

### **SATA1 IDE Interface**

This setting is used to **Enable** or Disable the serial controller for SATA1.

### **First Boot Device From**

Use this setting to select the first boot device as being **P-ATA** or S-ATA.

## ▶ **Configuration nVidia RAID ROM**

### **RAID Option ROM**

This setting is used to Enable or **Disable** the nVidia ROM.

## ▶ **Floppy Configuration**

### **Floppy A**

Move the cursor to these fields via up and down <arrow> keys to select the floppy type. The options are Disabled, 360 KB 5 1/4", 1.2 MB 5 1/4", 720 KB 3 1/2", **1.44 MB 3 1/2"**, and 2.88 MB 3 1/2".

### **Floppy B**

Move the cursor to these fields via up and down <arrow> keys to select the floppy type. The options are **Disabled**, 360 KB 5 1/4", 1.2 MB 5 1/4", 720 KB 3 1/2", 1.44 MB 3 1/2", and 2.88 MB 3 1/2".

### **Onboard Floppy Controller**

Use this setting to **Enable** or Disable the onboard floppy controller.

## ► PCI/PnP Configuration

### Clear NVRAM

Select Yes to clear NVRAM during boot-up. The options are Yes and **No**.

### Plug & Play OS

Select Yes to allow the OS to configure Plug & Play devices. (This is not required for system boot if your system has an OS that supports Plug & Play.) Select **No** to allow AMIBIOS to configure all devices in the system.

### PCI Latency Timer

This option sets the latency of all PCI devices on the PCI bus. Select a value to set the PCI latency in PCI clock cycles. Options are 32, **64**, 96, 128, 160, 192, 224 and 248.

### Allocate IRQ to PCI VGA

Set this value to allow or restrict the system from giving the VGA adapter card an interrupt address. The options are **Yes** and No.

### Palette Snooping

Select "Enabled" to inform the PCI devices that an ISA graphics device is installed in the system in order for the graphics card to function properly. The options are Enabled and **Disabled**.

### PCI IDE BusMaster

Set this value to allow or prevent the use of PCI IDE busmastering. Select "Enabled" to allow AMI BIOS to use PCI busmaster for reading and writing to IDE drives. The options are **Disabled** and Enabled.

### Offboard PCI/ISA IDE Card

This option allows the user to assign a PCI slot number to an Off-board PCI/ISA IDE card in order for it to function properly. The options are **Auto**, PCI Slot1, PCI Slot2, PCI Slot3, PCI Slot4, PCI Slot5, and PCI Slot6.

### IRQ3/IRQ4/IRQ5/IRQ7/IRQ9/IRQ10/IRQ11/IRQ14/IRQ15

This feature specifies the availability of an IRQ to be used by a PCI/PnP device. Select Reserved for the IRQ to be used by a Legacy ISA device. The options are

**Available** and Reserved.

### **DMA Channel0/Channel1/Channel3/Channel5/Channel6/Channel7**

Select Available to indicate that a specific DMA channel is available to be used by a PCI/PnP device. Select Reserved if the DMA channel specified is reserved for a Legacy ISA device. The options are **Available** and Reserved.

### **Reserved Memory Size**

This feature specifies the size of memory block to be reserved for Legacy ISA devices. The options are **Disabled**, 16K, 32K and 64K.

## **► Super IO Configuration**

### **Serial Port1 Address**

This option specifies the base I/O port address and Interrupt Request address of serial port 1. Select "Disabled" to prevent the serial port from accessing any system resources. When this option is set to *Disabled*, the serial port physically becomes unavailable. Select "3F8/IRQ4" to allow the serial port to use 3F8 as its I/O port address and IRQ 4 for the interrupt address. The options are Disabled, **3F8/IRQ4**, 3E8/IRQ4 and 2E8/IRQ3.

### **Serial Port2 Address**

This option specifies the base I/O port address and Interrupt Request address of serial port 2. Select "Disabled" to prevent the serial port from accessing any system resources. When this option is set to "Disabled", the serial port physically becomes unavailable. Select "2F8/IRQ3" to allow the serial port to use 2F8 as its I/O port address and IRQ 3 for the interrupt address. The options are Disabled, **2F8/IRQ3**, 3E8/IRQ4 and 2E8/IRQ3.

### **Serial Port 2 Mode**

Tells BIOS which mode to select for serial port 2. The options are **Normal**, IrDA and ASKIR.

### **Parallel Port Address**

This option specifies the I/O address used by the parallel port. Select Disabled to prevent the parallel port from accessing any system resources. When the value of this option is set to Disabled, the printer port becomes unavailable. Select **378** to allow the parallel port to use 378 as its I/O port address. The majority of parallel

ports on computer systems use IRQ7 and I/O Port 378H as the standard setting. Select 278 to allow the parallel port to use 278 as its I/O port address. Select 3BC to allow the parallel port to use 3BC as its I/O port address.

### **Parallel Port Mode**

Specify the parallel port mode. The options are **Normal**, Bi-directional, EPP and ECP.

### **Parallel Port IRQ**

Select the IRQ (interrupt request) for the parallel port. The options are IRQ5 and **IRQ7**.

## ▶ **Chipset Menu**

### ▶ **North Bridge Configuration**

#### ▶ **Memory Configuration**

##### **Memclock Mode**

This setting determines how the memory clock is set. **Auto** has the memory clock by code and Limit allows the user to set a standard value.

##### **MCT Timing Mode**

Sets the timing mode for memory. Options are **Auto** and Manual.

##### **User Configuration Mode**

Options are Auto and Manual.

##### **Bank Interleaving**

Use this setting to control bank interleaving. Options are **Auto** and Disabled.

##### **Burst Length**

Use this setting to set the memory burst length. 64-bit Dq must use 4 beats. Options are 8 beats, **4 beats** and 2 beats.

### **Hardware Memory Hole**

When "Enabled", allows software memory remapping around the memory hole. Options are Enabled and **Disabled**. Note: this is only supported by Rev E0 processors and above.

### **Node Interleaving**

Use this setting to Enable or **Disable** node interleaving.

### **Bank Swizzle Mode**

The options are Enabled and **Disabled**.

## ▶ **ECC Configuration**

### **DRAM ECC Enable**

DRAM ECC allows hardware to report and correct memory errors automatically. Options are **Enabled** and Disabled.

### **MCA DRAM ECC Logging**

When Enabled, MCA DRAM ECC logging and reporting is enabled. Options are Enabled and **Disabled**.

### **ECC Chipkill**

Allows the user to enable ECC Chipkill. Options are Enabled and **Disabled**.

### **DRAM Scrub Redirect**

Allows system to correct DRAM ECC errors immediately, even with background scrubbing on. Options are Enabled and **Disabled**.

### **DRAM BG Scrub**

Corrects memory errors so later reads are correct. Options are **Disabled** and various times in nanoseconds and microseconds.

### **L2 Cache BG Scrub**

Allows L2 cache RAM to be corrected when idle. Options are **Disabled** and various times in nanoseconds and microseconds.

### **Data Cache BG Scrub**

Allows L1 cache RAM to be corrected when idle. Options are **Disabled** and various times in nanoseconds and microseconds.

## ▶ **IOMMU Option Menu**

### **IOMMU Mode**

IOMMU is supported on Linux-based systems to convert 32-bit I/O addresses to 64-bit. Options are **Disabled**, Best Fit and Absolute. Selecting the Best Fit or Absolute settings allows the user to select aperture size.

### **Power Down Control**

Allows DIMMs to power down when not in use by deasserting the clock enable signal. Options are **Auto** and Disabled.

### **Memory Ticking Parameters**

Allows the user to select which CPU Node's timing parameters (memory clock, etc.) to display. Options are CPU Node 0, CPU Node1, CPU Node 2 and CPU Node 3.

## ▶ **South Bridge Configuration**

### **CPU Spread Spectrum**

This setting is used to enable spread spectrum for the CPU. Options are **Disabled** and Center Spread.

### **SATA Spread Spectrum**

This setting is used to enable spread spectrum for the SATA. Options are **Disabled** and Down Spread.

### **PCI Express Spread Spectrum**

This setting is used to enable spread spectrum for the PCI Express. Options are **Disabled** and Down Spread.

### **Primary Video**

This setting is used to switch the PCI bus scanning order while searching for the video card. It allows the user to select the type of primary VGA in case of multiple video controllers. Options are Slave PCI-Express and **Master PCI-Express**.

## ▶ **ACPI Configuration**

### ▶ **Advanced ACPI Configuration**

#### **ACPI 2.0 Features**

"Yes" enables RSDP pointers to 64-bit fixed system description pages. Options are Yes and **No**.

#### **ACPI APIC Support**

Select "Enabled" to allow the ACPI APIC table pointer to be included in the RSDP pointer list. The options are **Enabled** and Disabled.

#### **ACPI SRAT Table**

Use this setting to **Enable** or Disable the building of an ACPI SRAT table.

#### **AMI OEMB Table**

When Enabled, tells BIOS to include the OEMB table pointer to R(X) SDT pointer lists. Options are **Enabled** and Disabled.

#### **Headless Mode**

Enable this setting to activate the Headless Operation Mode through ACPI. The options are Enabled and **Disabled**.

## ▶ **Power Menu**

#### **Power Button Mode**

Allows the user to change the function of the power button. Options are **On/Off** and Suspend.

#### **Restore on AC Power Loss**

This setting allows you to choose how the system will react when power returns after an unexpected loss of power. The options are Power Off, Power On and **Last State**.

#### **Watch Dog Timer**

This setting is used to Enable or **Disable** the Watch Dog Timer function. It must be used in conjunction with the Watch Dog jumper (see jumper section for details).

---

## ► Hyper Transport Configuration

### **CPU0: CPU1 HT Link Speed**

The HT link will run at the speed specified in this setting if it is slower than or equal to the system clock and if the board is capable. Options are **Auto**, 200 MHz, 400 MHz, 600 MHz, 800 MHz and 1 GHz.

### **CPU0: CPU1 HT Link Width**

The HT link will run at the width specified in this setting. Options are **Auto**, 2 bit, 4 bit, 8 bit and 16 bit.

### **CPU0: PCI-X0 HT Link Speed**

The HT link will run at the speed specified in this setting if it is slower than or equal to the system clock and if the board is capable. Options are **Auto**, 200 MHz, 400 MHz, 600 MHz, 800 MHz and 1 GHz.

### **CPU0: PCI-X0 HT Link Width**

The HT link will run at the width specified in this setting. Options are **Auto**, 2 bit, 4 bit, 8 bit and 16 bit.

### **CPU: HT\_Slot HT1 Link Speed**

This setting becomes accessible when a card is installed to the J34 HT slot. The HT link will run at the speed specified in this setting if it is slower than or equal to the system clock and if the board is capable. Options are **Auto**, 200 MHz, 400 MHz, 600 MHz, 800 MHz and 1 GHz.

### **CPU: HT\_Slot HT1 Link Width**

This setting becomes accessible when a card is installed to the J34 HT slot. The HT link will run at the width specified in this setting. Options are **Auto**, 2 bit, 4 bit, 8 bit and 16 bit.

## ► MPS Configuration

### **MPS Revision**

This setting allows the user to select the MPS revision level. The options are 1.1 and 1.4.

▶ **PCI Express Configuration**

**Active State Power Management**

Use this setting to Enable or **Disable** PCI Express L0s and L1 link power states.

▶ **AMD PowerNow Configuration**

This setting is used to **Enable** or Disable the AMD PowerNow feature.

▶ **SMBIOS Configuration**

**SMBIOS SMI Support**

**Enable** or Disable SMBIOS wrapper support for PnP function 50h-54h.

▶ **Remote Access Configuration**

**Remote Access**

Allows you to **Enable** or Disable Remote Access.

▶ **USB Configuration**

This screen will display the module version and all USB enabled devices.

**USB Controller Support**

Enable the controller for your USB ports. Options are Disabled, USB 1.1 only and **USB 1.1 + USB 2.0**.

**Legacy USB Support**

Select "Enabled" to enable the support for USB Legacy. Disable Legacy support if there are no USB devices installed in the system. The options are Disabled, **Enabled** and Auto.

**USB 2.0 Controller Mode**

Select the controller mode for your USB ports. Options are **HiSpeed** and FullSpeed. (HiSpeed=480 Mbps, FullSpeed=12 Mbps).

**BIOS EHCI Hand-Off**

**Enable** or Disable a workaround for OS's without EHCI hand-off support.

## ► System Health Monitor

### CPU Overheat Temperature

Use the "+" and "-" keys to set the CPU temperature threshold to between 65° and 90° C. When this threshold is exceeded, the overheat LED on the chassis will light up and an alarm will sound. The LED and alarm will turn off once the CPU temperature has dropped to 5 degrees below the threshold set. The default setting is **78° C**.

Other items in the submenu are all systems monitor displays for the following information:

CPU1 Temperature, CPU2 Temperature, CPU3 Temperature, CPU4 Temperature, CPU1 Vcore, CPU2 Vcore, CPU3 Vcore, CPU4 Vcore, +5Vin, +12Vin, -12Vcc (V), and Battery Voltage.

## ► System Fan Monitor

### Fan Speed Control Modules

This feature allows the user to determine how the system will control the speed of the onboard fans. If the option is set to "Server Mode", the fan speed will vary between full speed (12V) and reduced speed (9V), based on system temperature. Selecting to "Disable" will have the onboard fans to continuously run at full speed (12V). The options are **1) Disable, Full Speed** and **2) Server Mode**.

### FAN1 Speed through FAN9 Speed

The speeds of the onboard fans (in rpm) are displayed here. FAN7 is intended to be used for the CPU1 heatsink fan and FAN8 is intended to be used for the CPU2 heatsink fan.

## 7-4 Boot Menu

This feature allows the user to configure the following items:

### ► Boot Settings Configuration

#### Quick Boot

If Enabled, this option will skip certain tests during POST to reduce the time needed for the system to boot up. The options are **Enabled** and Disabled.

#### Quiet Boot

If **Disabled**, normal POST messages will be displayed on boot-up. If Enabled, this display the OEM logo instead of POST messages.

#### Add-On ROM Display Mode

This setting controls the display of add-on ROM (read-only memory) messages. Select "**Force BIOS**" to allow the computer system to force a third party BIOS to display during system boot. Select "Keep Current" to allow the computer system to display the BIOS information during system boot.

#### Boot up Num-Lock

Set this to "On" to allow the Number Lock setting to be modified during boot up. The options are **On** and Off.

#### PS/2 Mouse Support

This setting is to specify PS/2 mouse support. The options are **Auto**, Enabled and Disabled.

#### Wait for 'F1' If Error

Enable to activate the Wait for F1 if Error function. The options are **Enabled** and Disabled.

#### Hit 'DEL' Message Display

Enable to display the message telling the user to hit the DEL key to enter the setup utility. The options are **Enabled** and Disabled.

#### Interrupt 19 Capture

Enable to allow ROMs to trap Interrupt 19. The options are Enabled and **Disabled**.

### ▶ **Boot Device Priority**

This feature allows the user to prioritize the sequence for the Boot Device. The devices to set are:

- 1st Boot Device
- 2nd Boot Device
- 3rd Boot Device
- 4th Boot Device

### ▶ **Hard Disk Drives**

This feature allows the user to specify the Boot sequence from available hard disk drives.

### ▶ **Removable Drives**

This feature allows the user to specify the Boot sequence from available removable drives.

#### **1st Drive**

Specifies the boot sequence for the 1st Removable Drive. The options are **1st Floppy Drive** and Disabled.

### **OS Installation**

Specify the OS used. Options are Linux and **Other**.

### **Onboard SCSI Host RAID**

Use this setting to Enable or **Disable** the SCSI Host RAID.

## 7-5 Security Menu

AMI BIOS provides a Supervisor and a User password. If you use both passwords, the Supervisor password must be set first.

### **Change Supervisor Password**

Select this option and press <Enter> to access the sub menu, and then type in the password.

### **Change User Password**

Select this option and press <Enter> to access the sub menu, and then type in the password.

### **Boot Sector Virus Protection**

This option is near the bottom of the Security Setup screen. Select "Disabled" to deactivate the Boot Sector Virus Protection. Select "Enabled" to enable boot sector protection. When "Enabled", AMI BIOS displays a warning when any program (or virus) issues a Disk Format command or attempts to write to the boot sector of the hard disk drive. The options are Enabled and **Disabled**.

## 7-6 Exit Menu

Select the Exit tab from AMI BIOS Setup Utility screen to enter the Exit BIOS Setup screen.

### **Save Changes and Exit**

When you have completed the system configuration changes, select this option to leave BIOS Setup and reboot the computer, so the new system configuration parameters can take effect. Select Save Changes and Exit from the Exit menu and press <Enter>.

### **Discard Changes and Exit**

Select this option to quit BIOS Setup without making any permanent changes to the system configuration and reboot the computer. Select Discard Changes and Exit from the Exit menu and press <Enter>.

### **Discard Changes**

Select this option and press <Enter> to discard all the changes and return to AMI BIOS Utility Program.

### **Load Optimal Defaults**

To set this feature, select Load Optimal Defaults from the Exit menu and press <Enter>. Then Select "OK" to allow BIOS to automatically load the Optimal Defaults as the BIOS Settings. The Optimal settings are designed for maximum system performance, but may not work best for all computer applications.

### **Load Fail-Safe Defaults**

To set this feature, select Load Fail-Safe Defaults from the Exit menu and press <Enter>. The Fail-Safe settings are designed for maximum system stability, but not maximum performance.

## Appendix A

### BIOS Error Beep Codes

During the POST (Power-On Self-Test) routines, which are performed each time the system is powered on, errors may occur.

**Non-fatal errors** are those which, in most cases, allow the system to continue the boot-up process. The error messages normally appear on the screen.

**Fatal errors** are those which will not allow the system to continue the boot-up procedure. If a fatal error occurs, you should consult with your system manufacturer for possible repairs.

These fatal errors are usually communicated through a series of audible beeps. The numbers on the fatal error list, on the following page, correspond to the number of beeps for the corresponding error. All errors listed, with the exception of Beep Code 8, are fatal errors.

POST codes may be read on the debug LEDs located beside the LAN port on the serverboard backplane. See the description of the Debug LEDs (LED1 and LED2) in Chapter 5.

#### A-1 AMIBIOS Error Beep Codes

<b>Beep Code</b>	<b>Error Message</b>	<b>Description</b>
1 beep	Refresh	Circuits have been reset. (Ready to power up.)
5 short, 1 long	Memory error	No memory detected in system
8 beeps	Display memory read/write error	Video adapter missing or with faulty memory

# Notes

## Appendix B

### BIOS POST Checkpoint Codes

When AMIBIOS performs the Power On Self Test, it writes checkpoint codes to I/O port 0080h. If the computer cannot complete the boot process, diagnostic equipment can be attached to the computer to read I/O port 0080h.

#### B-1 Uncompressed Initialization Codes

The uncompressed initialization checkpoint codes are listed in order of execution:

Checkpoint	Code Description
D0h	The NMI is disabled. Power on delay is starting. Next, the initialization code checksum will be verified.
D1h	Initializing the DMA controller, performing the keyboard controller BAT test, starting memory refresh and entering 4 GB flat mode next.
D3h	Starting memory sizing next.
D4h	Returning to real mode. Executing any OEM patches and setting the Stack next.
D5h	Passing control to the uncompressed code in shadow RAM at E000:0000h. The initialization code is copied to segment 0 and control will be transferred to segment 0.

## B-2 Bootblock Recovery Codes

The bootblock recovery checkpoint codes are listed in order of execution:

Checkpoint	Code Description
E0h	The onboard floppy controller if available is initialized. Next, beginning the base 512 KB memory test.
E1h	Initializing the interrupt vector table next.
E2h	Initializing the DMA and Interrupt controllers next.
E6h	Enabling the floppy drive controller and Timer IRQs. Enabling internal cache memory.
Edh	Initializing the floppy drive.
Eeh	Looking for a floppy diskette in drive A:. Reading the first sector of the diskette.
Efh	A read error occurred while reading the floppy drive in drive A:.
F0h	Next, searching for the AMIBOOT.ROM file in the root directory.
F1h	The AMIBOOT.ROM file is not in the root directory.
F2h	Next, reading and analyzing the floppy diskette FAT to find the clusters occupied by the AMIBOOT.ROM file.
F3h	Next, reading the AMIBOOT.ROM file, cluster by cluster.
F4h	The AMIBOOT.ROM file is not the correct size.
F5h	Next, disabling internal cache memory.
FBh	Next, detecting the type of flash ROM.
FCh	Next, erasing the flash ROM.
FDh	Next, programming the flash ROM.
FFh	Flash ROM programming was successful. Next, restarting the system BIOS.

## B-3 Uncompressed Initialization Codes

The following runtime checkpoint codes are listed in order of execution.

These codes are uncompressed in F0000h shadow RAM.

Checkpoint	Code Description
03h	The NMI is disabled. Next, checking for a soft reset or a power on condition.
05h	The BIOS stack has been built. Next, disabling cache memory.
06h	Uncompressing the POST code next.
07h	Next, initializing the CPU and the CPU data area.
08h	The CMOS checksum calculation is done next.
0Ah	The CMOS checksum calculation is done. Initializing the CMOS status register for date and time next.
0Bh	The CMOS status register is initialized. Next, performing any required initialization before the keyboard BAT command is issued.
0Ch	The keyboard controller input buffer is free. Next, issuing the BAT command to the keyboard controller.
0Eh	The keyboard controller BAT command result has been verified. Next, performing any necessary initialization after the keyboard controller BAT command test.
0Fh	The initialization after the keyboard controller BAT command test is done. The keyboard command byte is written next.
10h	The keyboard controller command byte is written. Next, issuing the Pin 23 and 24 blocking and unblocking command.
11h	Next, checking if <End or <Ins> keys were pressed during power on. Initializing CMOS RAM if the Initialize CMOS RAM in every boot AMIBIOS POST option was set in AMIBCP or the <End> key was pressed.
12h	Next, disabling DMA controllers 1 and 2 and interrupt controllers 1 and 2.
13h	The video display has been disabled. Port B has been initialized. Next, initializing the chipset.
14h	The 8254 timer test will begin next.
19h	Next, programming the flash ROM.
1Ah	The memory refresh line is toggling. Checking the 15 second on/off time next.
2Bh	Passing control to the video ROM to perform any required configuration before the video ROM test.
2Ch	All necessary processing before passing control to the video ROM is done. Looking for the video ROM next and passing control to it.
2Dh	The video ROM has returned control to BIOS POST. Performing any required processing after the video ROM had control
23h	Reading the 8042 input port and disabling the MEGAKEY Green PC feature next. Making the BIOS code segment writable and performing any necessary configuration before initializing the interrupt vectors.
24h	The configuration required before interrupt vector initialization has completed. Interrupt vector initialization is about to begin.

Checkpoint	Code Description
25h	Interrupt vector initialization is done. Clearing the password if the POST DIAG switch is on.
27h	Any initialization before setting video mode will be done next.
28h	Initialization before setting the video mode is complete. Configuring the monochrome mode and color mode settings next.
2Ah	Bus initialization system, static, output devices will be done next, if present. See the last page for additional information.
2Eh	Completed post-video ROM test processing. If the EGA/VGA controller is not found, performing the display memory read/write test next.
2Fh	The EGA/VGA controller was not found. The display memory read/write test is about to begin.
30h	The display memory read/write test passed. Look for retrace checking next.
31h	The display memory read/write test or retrace checking failed. Performing the alternate display memory read/write test next.
32h	The alternate display memory read/write test passed. Looking for alternate display retrace checking next.
34h	Video display checking is over. Setting the display mode next.
37h	The display mode is set. Displaying the power on message next.
38h	Initializing the bus input, IPL, general devices next, if present. See the last page of this chapter for additional information.
39h	Displaying bus initialization error messages. See the last page of this chapter for additional information.
3Ah	The new cursor position has been read and saved. Displaying the Hit <DEL> message next.
3Bh	The Hit <DEL> message is displayed. The protected mode memory test is about to start.
40h	Preparing the descriptor tables next.
42h	The descriptor tables are prepared. Entering protected mode for the memory test next.
43h	Entered protected mode. Enabling interrupts for diagnostics mode next.
44h	Interrupts enabled if the diagnostics switch is on. Initializing data to check memory wraparound at 0:0 next.
45h	Data initialized. Checking for memory wraparound at 0:0 and finding the total system memory size next.
46h	The memory wraparound test is done. Memory size calculation has been done. Writing patterns to test memory next.
47h	The memory pattern has been written to extended memory. Writing patterns to the base 640 KB memory next.
48h	Patterns written in base memory. Determining the amount of memory below 1 MB next.
49h	The amount of memory below 1 MB has been found and verified.
4Bh	The amount of memory above 1 MB has been found and verified. Checking for a soft reset and clearing the memory below 1 MB for the soft reset next. If this is a power on situation, going to checkpoint 4Eh next.

Checkpoint	Code Description
4Ch	The memory below 1 MB has been cleared via a soft reset. Clearing the memory above 1 MB next.
4Dh	The memory above 1 MB has been cleared via a soft reset. Saving the memory size next. Going to checkpoint 52h next.
4Eh	The memory test started, but not as the result of a soft reset. Displaying the first 64 KB memory size next.
4Fh	The memory size display has started. The display is updated during the memory test. Performing the sequential and random memory test next.
50h	The memory below 1 MB has been tested and initialized. Adjusting the displayed memory size for relocation and shadowing next.
51h	The memory size display was adjusted for relocation and shadowing.
52h	The memory above 1 MB has been tested and initialized. Saving the memory size information next.
53h	The memory size information and the CPU registers are saved. Entering real mode next.
54h	Shutdown was successful. The CPU is in real mode. Disabling the Gate A20 line, parity, and the NMI next.
57h	The A20 address line, parity, and the NMI are disabled. Adjusting the memory size depending on relocation and shadowing next.
58h	The memory size was adjusted for relocation and shadowing. Clearing the Hit <DEL> message next.
59h	The Hit <DEL> message is cleared. The <WAIT...> message is displayed. Starting the DMA and interrupt controller test next.
60h	The DMA page register test passed. Performing the DMA Controller 1 base register test next.
62h	The DMA controller 1 base register test passed. Performing the DMA controller 2 base register test next.
65h	The DMA controller 2 base register test passed. Programming DMA controllers 1 and 2 next.
66h	Completed programming DMA controllers 1 and 2. Initializing the 8259 interrupt controller next.
67h	Completed 8259 interrupt controller initialization.
7Fh	Extended NMI source enabling is in progress.
80h	The keyboard test has started. Clearing the output buffer and checking for stuck keys. Issuing the keyboard reset command next.
81h	A keyboard reset error or stuck key was found. Issuing the keyboard controller interface test command next.
82h	The keyboard controller interface test completed. Writing the command byte and initializing the circular buffer next.
83h	The command byte was written and global data initialization has completed. Checking for a locked key next.
84h	Locked key checking is over. Checking for a memory size mismatch with CMOS RAM data next.
85h	The memory size check is done. Displaying a soft error and checking for a password or bypassing WINBIOS Setup next.

Checkpoint	Code Description
86h	The password was checked. Performing any required programming before WINBIOS Setup next.
87h	The programming before WINBIOS Setup has completed. Uncompressing the WINBIOS Setup code and executing the AMIBIOS Setup or WINBIOS Setup utility next.
88h	Returned from WINBIOS Setup and cleared the screen. Performing any necessary programming after WINBIOS Setup next.
89h	The programming after WINBIOS Setup has completed. Displaying the power on screen message next.
8Ch	Programming the WINBIOS Setup options next.
8Dh	The WINBIOS Setup options are programmed. Resetting the hard disk controller next.
8Fh	The hard disk controller has been reset. Configuring the floppy drive controller next.
91h	The floppy drive controller has been configured. Configuring the hard disk drive controller next.
95h	Initializing the bus option ROMs from C800 next. See the last page of this chapter for additional information.
96h	Initializing before passing control to the adaptor ROM at C800.
97h	Initialization before the C800 adaptor ROM gains control has completed. The adaptor ROM check is next.
98h	The adaptor ROM had control and has now returned control to BIOS POST. Performing any required processing after the option ROM returned control.
99h	Any initialization required after the option ROM test has completed. Configuring the timer data area and printer base address next.
9Ah	Set the timer and printer base addresses. Setting the RS-232 base address next.
9Bh	Returned after setting the RS-232 base address. Performing any required initialization before the Coprocessor test next.
9Ch	Required initialization before the Coprocessor test is over. Initializing the Coprocessor next.
9Dh	Coprocessor initialized. Performing any required initialization after the Coprocessor test next.
9Eh	Initialization after the Coprocessor test is complete. Checking the extended keyboard, keyboard ID, and Num Lock key next. Issuing the keyboard ID command next.
A2h	Displaying any soft errors next.
A3h	The soft error display has completed. Setting the keyboard typematic rate next.
A4h	The keyboard typematic rate is set. Programming the memory wait states next.
A5h	Memory wait state programming is over. Clearing the screen and enabling parity and the NMI next.
A7h	NMI and parity enabled. Performing any initialization required before passing control to the adaptor ROM at E000 next.
A8h	Initialization before passing control to the adaptor ROM at E000h completed. Passing control to the adaptor ROM at E000h next.

---

---

<b>Checkpoint</b>	<b>Code Description</b>
A9h	Returned from adaptor ROM at E000h control. Performing any initialization required after the E000 option ROM had control next.
Aah	Initialization after E000 option ROM control has completed. Displaying the system configuration next.
Abh	Uncompressing the DMI data and executing DMI POST initialization next.
B0h	The system configuration is displayed.
B1h	Copying any code to specific areas.
00h	Code copying to specific areas is done. Passing control to INT 19h boot loader next.

# Notes

## Appendix C

### System Specifications

#### Processors

Quad AMD Opteron™ 800 Series 64-bit processors in 940-pin micro PGA ZIF sockets

**Note:** Please refer to our web site for a complete listing of supported processors.

#### Chipset

nVidia nForce Pro 2200 (CK804)/AMD 8132 chipset

#### BIOS

8 Mb AMIBIOS® Flash ROM

#### Memory Capacity

Sixteen 184-pin DIMM sockets supporting up to 32 GB of registered ECC DDR400/333 or up to 64 GB of registered ECC DDR266 SDRAM

**Note:** See the memory section in Chapter 5 for details.

#### SATA Controller

On-chip (nVidia nForce Pro 2200) controller for 4-port SATA

#### SCSI Controller (4040C-8R only)

Adaptec AIC-7902W controller for dual-channel SCSI

#### SATA/SCSI Drive Bays

Five (5) hot-swap drive bays to house four (4) SATA or five (5) SCSI drives

#### Peripheral Drive Bays

One (1) floppy drive

### **Serverboard**

4040C-TR: H8QCE (Extended ATX form factor)

4040C-8R: H8QC8 (Extended ATX form factor)

Dimensions (both): 16 x 13 in (406 x 330 mm)

### **Chassis**

4040C-TR: SC748TQ-R1000 Form Factor: tower/4U rackmount

4040C-8R: SC748S-R1000 Form Factor: tower/4U rackmount

Dimensions (both): (HxWxD) 1.7 x 17.2 x 27 in. (43 x 437 x 686 mm)

### **Weight**

Gross (Bare Bone): 65.5 lbs (29.7 kg)

### **System Cooling** (fan speed controlled by BIOS setting, Chp 7)

Three (3) 9-cm chassis fans

Three (3) 8-cm exhaust fans

### **System Input Requirements**

AC Input Voltage: 100-240 VAC

Rated Input Current: 15A (115V) to 5A (230V)

Rated Input Frequency: 50-60 Hz

### **Power Supply**

Rated Output Power: 1000W (Part# PWS-1K01-1R)

Rated Output Voltages: +12V (83A), +5Vsb (4A)

### **BTU Rating**

4900 BTUs/hr (for rated output power of 1000W)

### **Operating Environment**

Operating Temperature: 10° to 35° C (50° to 95° F)

Non-operating Temperature: -40° to 70° C (-40° to 158° F)

Operating Relative Humidity: 8% to 90% (non-condensing)

Non-operating Relative Humidity: 5 to 95% (non-condensing)

## **Regulatory Compliance**

### Electromagnetic Emissions:

FCC Class A, EN 55022 Class A, EN 61000-3-2/-3-3, CISPR 22 Class A

### Electromagnetic Immunity:

EN 55024/CISPR 24, (EN 61000-4-2, EN 61000-4-3, EN 61000-4-4,  
EN 61000-4-5, EN 61000-4-6, EN 61000-4-8, EN 61000-4-11)

### Safety:

EN 60950/IEC 60950-Compliant, UL Listed (USA), CUL Listed (Canada), TUV  
Certified (Germany), CE Marking (Europe)

# Notes