

SUPERO®

SuperWorkstation

7047A-73
7047A-T

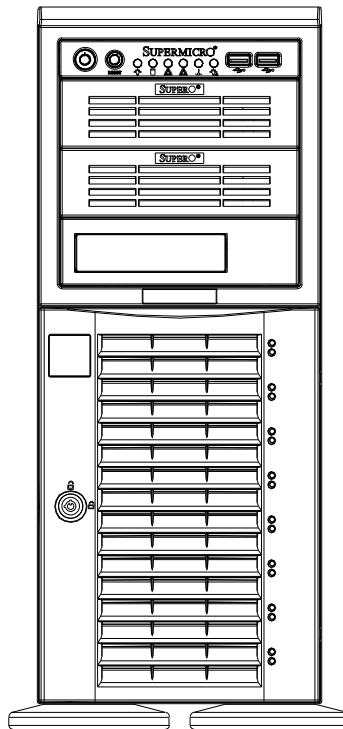

USER'S MANUAL

1.0

The information in this User's Manual has been carefully reviewed and is believed to be accurate. The vendor assumes no responsibility for any inaccuracies that may be contained in this document, makes no commitment to update or to keep current the information in this manual, or to notify any person or organization of the updates. **Please Note: For the most up-to-date version of this manual, please see our web site at www.supermicro.com.**

Super Micro Computer, Inc. ("Supermicro") reserves the right to make changes to the product described in this manual at any time and without notice. This product, including software and documentation, is the property of Supermicro and/or its licensors, and is supplied only under a license. Any use or reproduction of this product is not allowed, except as expressly permitted by the terms of said license.

IN NO EVENT WILL SUPERMICRO BE LIABLE FOR DIRECT, INDIRECT, SPECIAL, INCIDENTAL, SPECULATIVE OR CONSEQUENTIAL DAMAGES ARISING FROM THE USE OR INABILITY TO USE THIS PRODUCT OR DOCUMENTATION, EVEN IF ADVISED OF THE POSSIBILITY OF SUCH DAMAGES. IN PARTICULAR, SUPERMICRO SHALL NOT HAVE LIABILITY FOR ANY HARDWARE, SOFTWARE, OR DATA STORED OR USED WITH THE PRODUCT, INCLUDING THE COSTS OF REPAIRING, REPLACING, INTEGRATING, INSTALLING OR RECOVERING SUCH HARDWARE, SOFTWARE, OR DATA.

Any disputes arising between manufacturer and customer shall be governed by the laws of Santa Clara County in the State of California, USA. The State of California, County of Santa Clara shall be the exclusive venue for the resolution of any such disputes. Super Micro's total liability for all claims will not exceed the price paid for the hardware product.

FCC Statement: This equipment has been tested and found to comply with the limits for a Class A digital device pursuant to Part 15 of the FCC Rules. These limits are designed to provide reasonable protection against harmful interference when the equipment is operated in a commercial environment. This equipment generates, uses, and can radiate radio frequency energy and, if not installed and used in accordance with the manufacturer's instruction manual, may cause harmful interference with radio communications. Operation of this equipment in a residential area is likely to cause harmful interference, in which case you will be required to correct the interference at your own expense.

California Best Management Practices Regulations for Perchlorate Materials: This Perchlorate warning applies only to products containing CR (Manganese Dioxide) Lithium coin cells. "Perchlorate Material-special handling may apply. See www.dtsc.ca.gov/hazardouswaste/perchlorate"

WARNING: Handling of lead solder materials used in this product may expose you to lead, a chemical known to the State of California to cause birth defects and other reproductive harm.

Manual Revision 1.0
Release Date: March 13, 2012

Unless you request and receive written permission from Super Micro Computer, Inc., you may not copy any part of this document.

Information in this document is subject to change without notice. Other products and companies referred to herein are trademarks or registered trademarks of their respective companies or mark holders.

Copyright © 2012 by Super Micro Computer, Inc.
All rights reserved.

Printed in the United States of America

Preface

About This Manual

This manual is written for professional system integrators and PC technicians. It provides information for the installation and use of the SuperWorkstation 7047A-73/7047A-T. Installation and maintenance should be performed by experienced technicians only.

The SuperWorkstation 7047A-73/7047A-T is a high-end system based on the SC743TQ-1200B-SQ tower/4U rackmount chassis and the X9DA7 (7047A-73) or X9DAi (7047A-T) serverboard.

Manual Organization

Chapter 1: Introduction

The first chapter provides a checklist of the main components included with the system and describes the main features of the X9DA7 and X9DAi serverboards and the SC743TQ-1200B-SQ chassis.

Chapter 2: Server Installation

This chapter describes the steps necessary to setup the SuperWorkstation 7047A-73/7047A-T into a rack and check out the server configuration prior to powering up the system. If your system was ordered without processor and memory components, this chapter will refer you to the appropriate sections of the manual for their installation.

Chapter 3: System Interface

Refer here for details on the system interface, which includes the functions and information provided by the control panel on the chassis as well as other LEDs located throughout the system.

Chapter 4: System Safety

You should thoroughly familiarize yourself with this chapter for a general overview of safety precautions that should be followed when installing and servicing the SuperWorkstation 7047A-73/7047A-T.

Chapter 5: Advanced Serverboard Setup

Chapter 5 provides detailed information on the X9DA7/X9DAi serverboard, including the locations and functions of connections, headers and jumpers. Refer to this chapter when adding or removing processors or main memory and when reconfiguring the serverboard.

Chapter 6: Advanced Chassis Setup

Refer to Chapter 6 for detailed information on the SC743TQ-1200B-SQ chassis. You should follow the procedures given in this chapter when installing, removing or reconfiguring SAS or peripheral drives and when replacing system power supply units and cooling fans.

Chapter 7: BIOS

The BIOS chapter includes an introduction to BIOS and provides detailed information on running the CMOS Setup Utility.

Appendix A: BIOS Error Beep Codes

Appendix B: System Specifications

Notes

Table of Contents

Chapter 1 Introduction

1-1	Overview	1-1
1-2	Serverboard Features	1-2
	Processors	1-2
	Memory	1-2
	Onboard SAS (7047A-73 only)	1-2
	SATA	1-2
	PCI Expansion Slots	1-2
	Onboard Controllers/Ports	1-3
1-3	Chassis Features	1-3
	System Power	1-3
	SAS Subsystem	1-3
	Front Control Panel	1-3
	Cooling System	1-3
1-4	Contacting Supermicro	1-5

Chapter 2 Installation

2-1	Overview	2-1
2-2	Unpacking the System	2-1
2-3	Preparing for Setup	2-1
	Choosing a Setup Location	2-2
	Rack Precautions	2-2
	Server Precautions	2-2
	Rack Mounting Considerations	2-3
	Ambient Operating Temperature	2-3
	Reduced Airflow	2-3
	Mechanical Loading	2-3
	Circuit Overloading	2-3
	Reliable Ground	2-3
2-4	Installing the System into a Rack	2-4
	Identifying the Sections of the Rack Rails	2-4
	Installing the Chassis Rails	2-5
	Installing the Rack Rails	2-6
	Installing the System into the Rack	2-7

Chapter 3 System Interface

3-1	Overview	3-1
3-2	Control Panel Buttons	3-1
	Power	3-1
	Reset	3-1
3-3	Control Panel LEDs	3-2
	Power	3-2
	HDD	3-2
	NIC1	3-2
	NIC2	3-2
	Overheat/Fan Fail	3-2
	Power Fail	3-3
3-4	Drive Carrier LEDs	3-3

Chapter 4 System Safety

4-1	Electrical Safety Precautions	4-1
4-2	General Safety Precautions	4-2
4-3	ESD Precautions	4-3
4-4	Operating Precautions	4-4

Chapter 5 Advanced Serverboard Setup

5-1	Handling the Serverboard	5-1
	Precautions	5-1
	Unpacking	5-2
5-2	Serverboard Installation	5-2
5-3	Connecting Cables	5-3
	Connecting Data Cables	5-3
	Connecting Power Cables	5-3
	Connecting the Control Panel	5-3
5-4	I/O Ports	5-4
5-5	Processor and Heatsink Installation	5-5
	Installing an LGA 2011 Processor	5-5
	Installing a CPU Heatsink	5-8
	Removing the Heatsink	5-9
5-6	Installing Memory Modules	5-10
	Installing & Removing DIMMs	5-10
5-7	Adding PCI Add-On Cards	5-15
5-8	Serverboard Details	5-16
	X9DA7/X9DAi Quick Reference	5-17
5-9	Connector Definitions	5-19

5-10	Jumper Settings	5-25
5-11	Onboard Indicators.....	5-28
5-12	SAS and SATA Ports	5-29
5-13	Installing Software.....	5-30
	SuperDoctor III.....	5-31

Chapter 6 Advanced Chassis Setup

6-1	Static-Sensitive Devices.....	6-1
	Precautions	6-1
	Unpacking	6-1
6-2	Front Control Panel.....	6-3
6-3	System Fans	6-4
	Fan Failure	6-4
	Replacing Chassis Cooling Fans.....	6-4
6-4	Drive Bay Installation	6-6
	SAS/SATA Backplane.....	6-7
	Installing Components in the 5.25" Drive Bays	6-8
6-5	Power Supply	6-9
	Power Supply Failure.....	6-9

Chapter 7 BIOS

7-1	Introduction.....	7-1
	Starting BIOS Setup Utility.....	7-1
	How To Change the Configuration Data	7-1
	Starting the Setup Utility	7-2
7-2	Main Setup	7-2
7-3	Advanced Setup Configurations.....	7-3
7-4	Event Logs	7-20
7-5	Boot.....	7-22
7-6	Security	7-23
7-7	Save & Exit	7-24

Appendix A BIOS Error Beep Codes

Appendix B System Specifications

Chapter 1

Introduction

1-1 Overview

The 7047A-73/7047A-T is a high-end workstation comprised of two main sub-systems: the SC743TQ-1200B-SQ tower/4U chassis and the X9DA7/X9DAi dual Intel® Xeon® processor serverboard. Please refer to our web site for information on operating systems that have been certified for use with the SuperWorkstation 7047A-73/7047A-T (www.supermicro.com).

In addition to the serverboard and chassis, various hardware components have been included with the SuperWorkstation 7047A-73/7047A-T, as listed below:

- Two 8-cm hot-swap PWM "SuperQuiet" chassis fans (FAN-0104L4)
- One 9-cm PWM "SuperQuiet" exhaust fan (FAN-0103L4)
- Two active CPU heatsinks (SNK-P0050AP4)
- SAS/SATA Accessories
 - One SAS/SATA backplane (CSE-SAS-743TQ)
 - One iPass cable (CBL-0118L-03)
 - Eight hot-swap drive carriers [CSE-PT17L(B)]
- Optional:
 - Two 8-cm PWM fans (FAN-0104L4)
 - One rackmount kit [CSE-PT26L-(B)]

1-2 Serverboard Features

At the heart of the SuperWorkstation 7047A-73/7047A-T lies the X9DA7/X9DAi, a dual processor serverboard based on the Intel® C600 chipset. Below are the main features of the X9DA7/X9DAi. (See Figure 1-1 for a block diagram of the chipset).

Processors

The X9DA7/X9DAi supports single or dual Intel E5-2600 processors in LGA 2011 sockets. Please refer to the serverboard description pages on our web site for a complete listing of supported processors (www.supermicro.com).

Memory

The X9DA7/X9DAi has sixteen DIMM slots that can support up to 512 GB of registered/unbuffered ECC DDR3-1600/1333/1066/800 LRDIMMs (load-reduced DIMMs). See Chapter 5 for details.

Onboard SAS (7047A-73 only)

The X9DA7 includes an LSI 2308 SAS controller, which supports eight SAS2 ports. The hot-swap SAS drives are connected to a backplane that provides power, bus termination and configuration settings.

Note: The operating system you use must have RAID support to enable the hot-swap capability and RAID function of the SAS drives. RAID 0, 1, 5 and 10 are supported (RAID 5 is not supported with Linux OS). Refer to the following ftp site for setup guidelines <ftp://ftp.supermicro.com/driver/SAS/LSI/LSI_SAS_EmbMRAID_SWUG.pdf>.

SATA

A SATA controller is integrated into the chipset to provide a Serial ATA subsystem that supports RAID 0, 1, 5 and 10 (RAID 5 is not supported with Linux OS). The SATA drives are hot-swappable units. The 7047A-73 (X9DA7) supports two SATA 3.0 and four SATA 2.0 ports while the 7047A-T (X9DAi) supports six SATA 3.0 and four SATA 2.0 ports.

Note: The operating system you use must have RAID support to enable the hot-swap capability and RAID function of the Serial ATA drives.

PCI Expansion Slots

The X9DA7/X9DAi has three PCI-E 3.0 x16, two PCI-E 3.0 x8 and one PCI-E 3.0 x4 slots. Note that the expansion slots are enabled with CPUs, therefore if a CPU

socket is empty the PCI slots associated with it cannot be used. See Chapter 5 for details.

Onboard Controllers/Ports

The color-coded I/O ports include one COM port, six USB 2.0 ports, PS/2 mouse and keyboard ports, two Gb Ethernet ports and six HDA (High Definition Audio) ports.

1-3 Chassis Features

The SC743TQ-1200B-SQ is an ATX form factor chassis that can be used as a tower or mounted in a 4U rackmount configuration. The following is a general outline of the main features of the SC743TQ-1200B-SQ chassis.

System Power

The 7047A-73/7047A-T features a single 1200W power supply. This power supply unit has been designed to operate at a low noise level to make it ideal for use in a workstation environment.

SAS Subsystem

The SC743TQ-1200B-SQ chassis was designed to support eight SAS or SATA hard drives, which are hot-swappable units. (SAS is with 7047A-73 only).

Front Control Panel

The control panel on the SuperWorkstation 7047A-73/7047A-T provides you with system monitoring and control. LEDs indicate system power, HDD activity, network activity, overheat conditions and power supply failure. A main power button and a system reset button are also included.

Note: the power supply fail LED indicates the power supply fan has failed.

Cooling System

The SC743TQ-1200B-SQ chassis has an innovative "Super Quiet" cooling design that provides sufficient cooling at very low noise level - ideal for a workplace environment. The chassis includes two 8-cm hot-plug PWM (Pulse Width Modulation) system cooling fans located in the middle of the chassis. A 9-cm PWM exhaust fan is also located at the rear of the chassis.

**Figure 1-1. Intel C600 Chipset:
System Block Diagram**

Note: This is a general block diagram. Please see Chapter 5 for details.

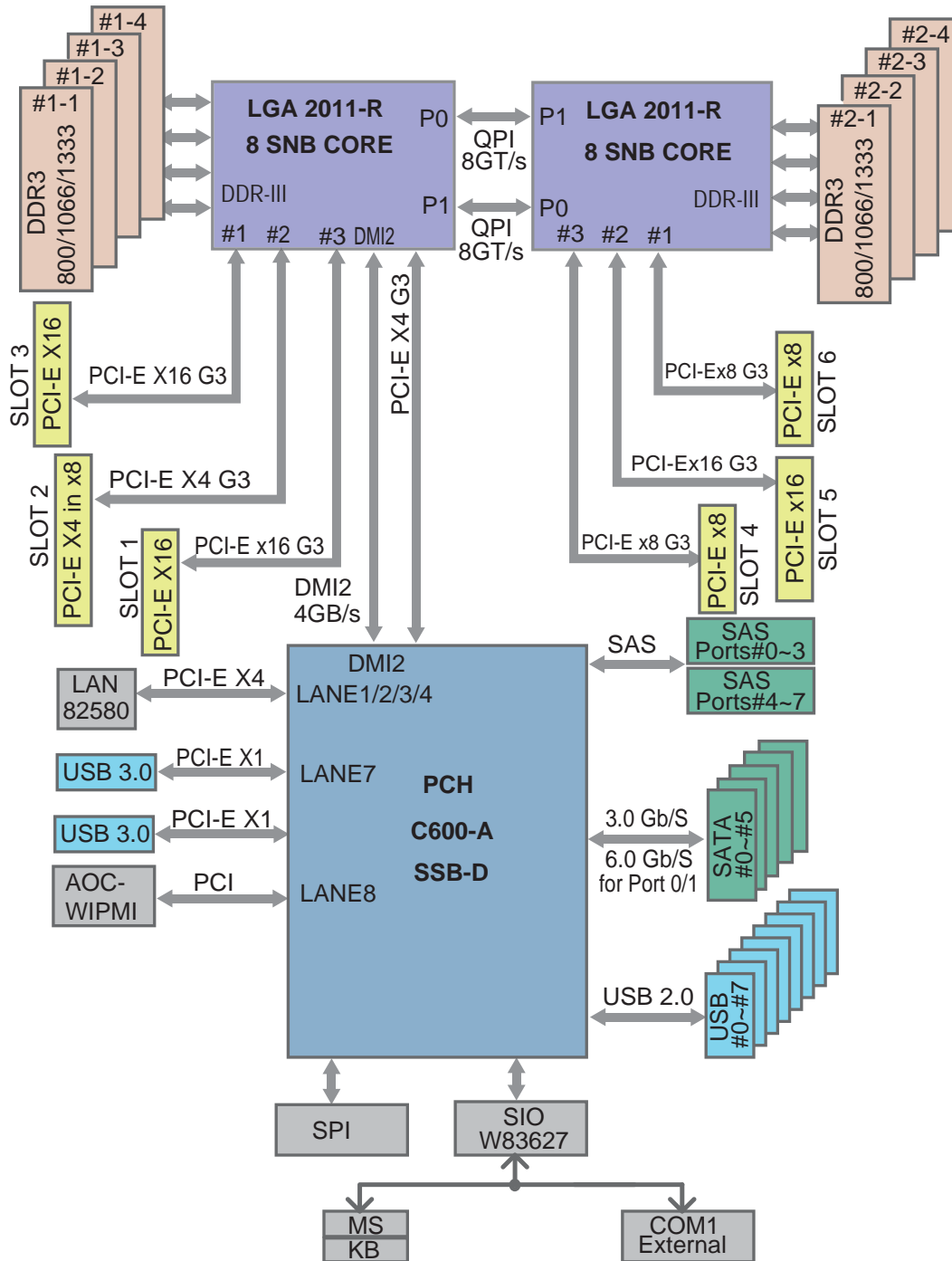

1-4 Contacting Supermicro

Headquarters

Address: Super Micro Computer, Inc.
980 Rock Ave.
San Jose, CA 95131 U.S.A.

Tel: +1 (408) 503-8000

Fax: +1 (408) 503-8008

Email: marketing@supermicro.com (General Information)
support@supermicro.com (Technical Support)

Web Site: www.supermicro.com

Europe

Address: Super Micro Computer B.V.
Het Sterrenbeeld 28, 5215 ML
's-Hertogenbosch, The Netherlands

Tel: +31 (0) 73-6400390

Fax: +31 (0) 73-6416525

Email: sales@supermicro.nl (General Information)
support@supermicro.nl (Technical Support)
rma@supermicro.nl (Customer Support)

Asia-Pacific

Address: Super Micro Computer, Inc.
4F, No. 232-1, Liancheng Rd.
Chung-Ho 235, Taipei County
Taiwan, R.O.C.

Tel: +886-(2) 8226-3990

Fax: +886-(2) 8226-3991

Web Site: www.supermicro.com.tw

Technical Support:

Email: support@supermicro.com.tw

Tel: 886-2-8226-5990

Notes

Chapter 2

Installation

2-1 Overview

This chapter provides a quick setup checklist to get your SuperWorkstation 7047A-73/7047A-T up and running. Following these steps in the order given should enable you to have the system operational within a minimum amount of time. This quick setup assumes that your system has come to you with the processor and memory preinstalled. If your system is not already fully integrated with a serverboard, processor, system memory etc., please turn to the chapter or section noted in each step for details on installing specific components.

The 7047A-73/7047A-T may be employed either as a tower or mounted in a rack as a 4U rackmount chassis. If using it as a tower unit, please read the Server Precautions in the next section before using the system for the first time.

2-2 Unpacking the System

You should inspect the box the system was shipped in and note if it was damaged in any way. If the system itself shows damage you should file a damage claim with the carrier who delivered it.

Decide on a suitable location for the SuperWorkstation. It should be situated in a clean, dust-free area that is well ventilated. Avoid areas where heat, electrical noise and electromagnetic fields are generated. You will also need it placed near a grounded power outlet. Be sure to read the Rack and Server Precautions in the next section.

2-3 Preparing for Setup

The box the system was shipped in may include two sets of rail assemblies, two rail mounting brackets and mounting screws needed for installing the system into a rack (optional kit). Follow the steps in the order given to complete the installation process in a minimum amount of time. Please read this section in its entirety before you begin the installation procedure outlined in the sections that follow.

Choosing a Setup Location

- Leave enough clearance in front of the rack to enable you to open the front door completely (~25 inches) and approximately 30 inches of clearance in the back of the rack to allow for sufficient airflow and ease in servicing.
- This product is not suitable for use with visual display work place devices according to §2 of the the German Ordinance for Work with Visual Display Units.



Warnings and Precautions!



Rack Precautions

- Ensure that the leveling jacks on the bottom of the rack are fully extended to the floor with the full weight of the rack resting on them.
- In single rack installation, stabilizers should be attached to the rack. In multiple rack installations, the racks should be coupled together.
- Always make sure the rack is stable before extending a component from the rack.
- You should extend only one component at a time - extending two or more simultaneously may cause the rack to become unstable.

Server Precautions

- Review the electrical and general safety precautions in Chapter 4.
- Determine the placement of each component in the rack *before* you install the rails.
- Install the heaviest server components on the bottom of the rack first, and then work up.
- Use a regulating uninterruptible power supply (UPS) to protect the server from power surges, voltage spikes and to keep your system operating in case of a power failure.

- Allow the hot plug SAS/SATA drives and power supply modules to cool before touching them.
- Always keep the rack's front door and all panels and components on the servers closed when not servicing to maintain proper cooling.

Rack Mounting Considerations

Ambient Operating Temperature

If installed in a closed or multi-unit rack assembly, the ambient operating temperature of the rack environment may be greater than the ambient temperature of the room. Therefore, consideration should be given to installing the equipment in an environment compatible with the manufacturer's maximum rated ambient temperature (T_{mra}).

Reduced Airflow

Equipment should be mounted into a rack so that the amount of airflow required for safe operation is not compromised.

Mechanical Loading

Equipment should be mounted into a rack so that a hazardous condition does not arise due to uneven mechanical loading.

Circuit Overloading

Consideration should be given to the connection of the equipment to the power supply circuitry and the effect that any possible overloading of circuits might have on overcurrent protection and power supply wiring. Appropriate consideration of equipment nameplate ratings should be used when addressing this concern.

Reliable Ground

A reliable ground must be maintained at all times. To ensure this, the rack itself should be grounded. Particular attention should be given to power supply connections other than the direct connections to the branch circuit (i.e. the use of power strips, etc.).

2-4 Installing the System into a Rack

This section provides information on installing the system into a rack unit. Rack installation requires the use of the optional rackmount kit.

There are a variety of rack units on the market, which may mean the assembly procedure will differ slightly. The following is a guideline for installing the system into a rack with the rack rails provided in the rackmount kit. You should also refer to the installation instructions that came with the rack unit you are using.

Identifying the Sections of the Rack Rails

The optional rackmount kit includes two rack rail assemblies. Each of these assemblies consist of three sections: an inner fixed chassis rail that secures to the chassis, an outer rack rail that secures directly to the rack itself and two rail brackets, which also attack to the rack (see Figure 2-1.) The inner and outer rails must be detached from each other to install.

To remove the inner chassis rail, pull it out as far as possible - you should hear a "click" sound as a locking tab emerges from inside the rail assembly and locks the inner rail. Depress the locking tab to pull the inner rail completely out. Do this for both assemblies (one for each side).

Figure 2-1. Identifying the Sections of the Rack Rails

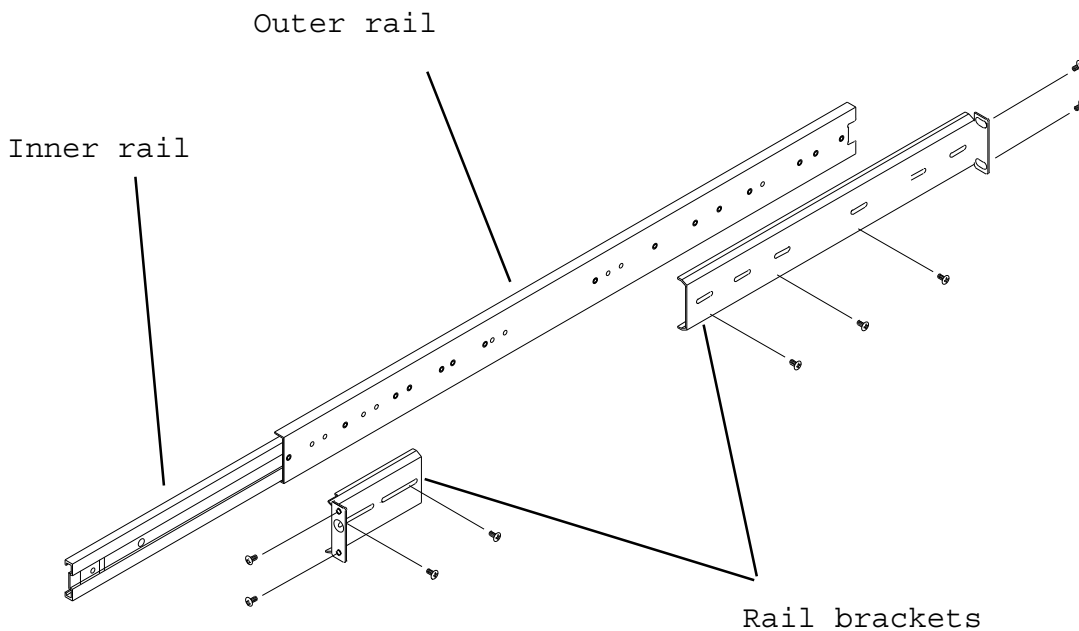

Installing the Chassis Rails

You will need to remove the top cover and the feet to add rack rails to the chassis. First, remove the top and right covers (top and left covers when standing as a tower chassis) by first removing the screws that secure them to the chassis. Depress the button on the top (side if tower) of the chassis to release the cover and then pull the cover off. Then unscrew the four feet and remove them from the chassis (see Figure 2-2).

You can now attach rack rails to the top and bottom (now the sides) of the chassis. First add the rack handles. Then position the inner chassis rail sections you just removed along the side of the chassis making sure the screw holes line up. Note that these two rails are left/right specific. Screw the rail securely to the side of the chassis (see Figure 2-3). Repeat this procedure for the other rail on the other side of the chassis. You will also need to attach the rail brackets when installing into a telco rack.

Locking Tabs: As mentioned, the chassis rails have a locking tab, which serves two functions. The first is to lock the system into place when installed and pushed fully into the rack, which is its normal position. Secondly, these tabs also lock the system in place when fully extended from the rack. This prevents the system from coming completely out of the rack when you pull it out for servicing.

Figure 2-2. Preparing to Install the Chassis Rails

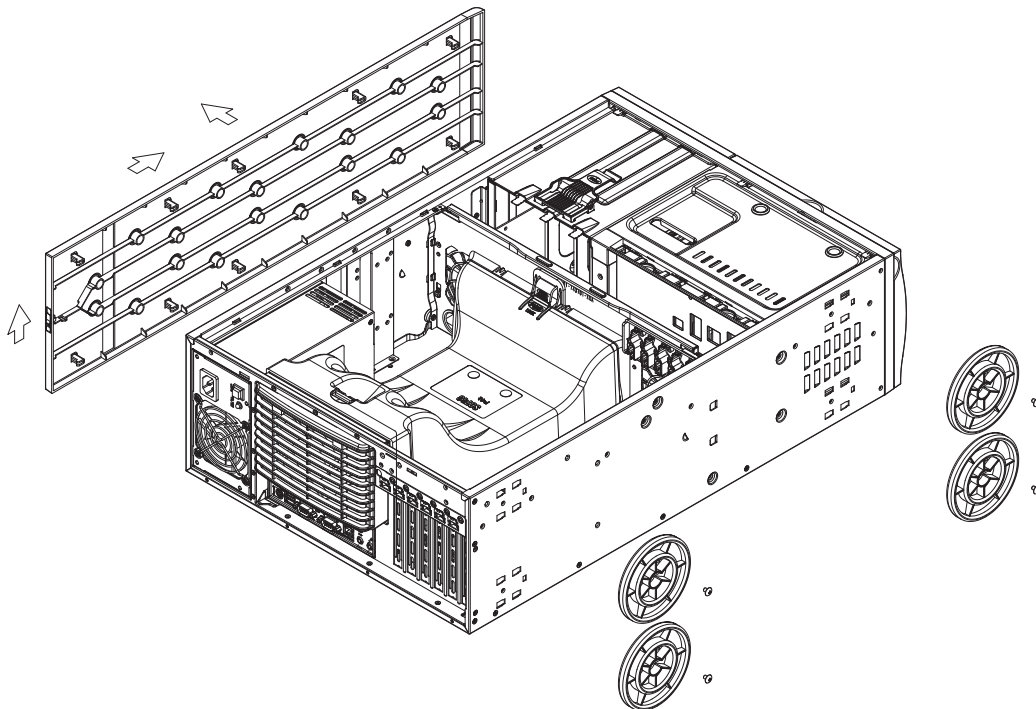
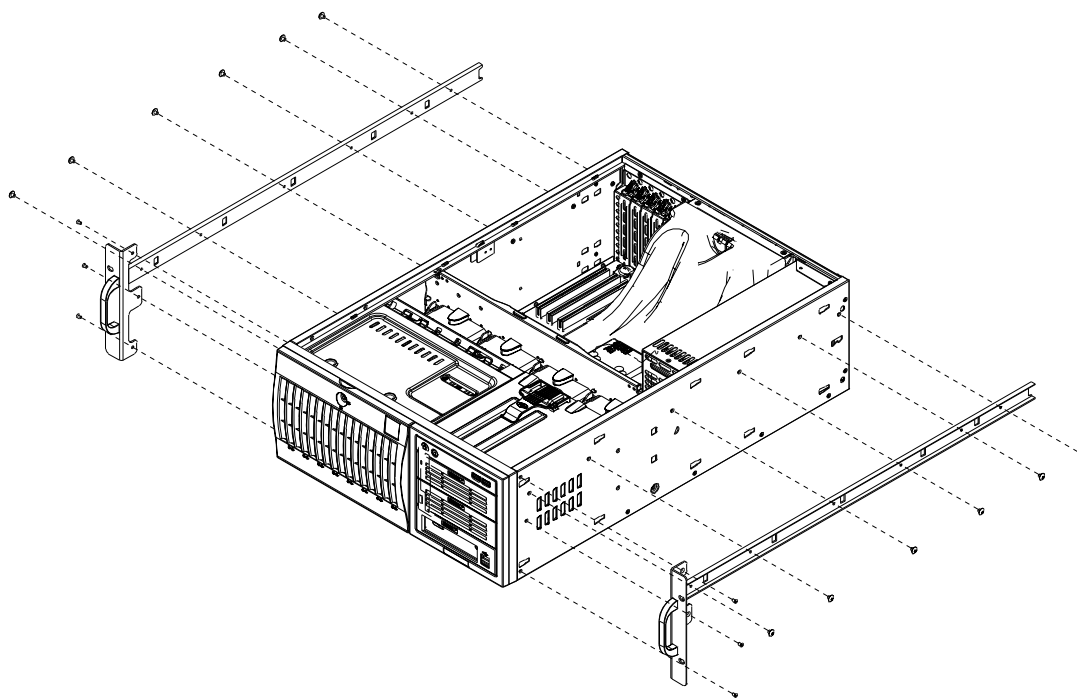

Figure 2-3. Installing the Rails to the Chassis



Installing the Rack Rails

Determine where you want to place the SuperWorkstation 7047A-73/7047A-T in the rack. (See Rack and Server Precautions in Section 2-3.) Position the fixed rack rail/sliding rail guide assemblies at the desired location in the rack, keeping the sliding rail guide facing the inside of the rack. Screw the assembly securely to the rack using the brackets provided. Attach the other assembly to the other side of the rack, making sure both are at the exact same height and with the rail guides facing inward.

Installing the System into the Rack

You should now have rails attached to both the chassis and the rack unit. The next step is to install the system into the rack. You should have two brackets in the rack mount kit. Install these first keeping in mind that they are left/right specific (marked with "L" and "R"). Then, line up the rear of the chassis rails with the front of the rack rails. Slide the chassis rails into the rack rails, keeping the pressure even on both sides (you may have to depress the locking tabs when inserting).

When the system has been pushed completely into the rack, you should hear the locking tabs "click". Finish by inserting and tightening the thumbscrews that hold the front of the chassis to the rack (see Figure 2-4).

Figure 2-4. Installing the System into a Rack

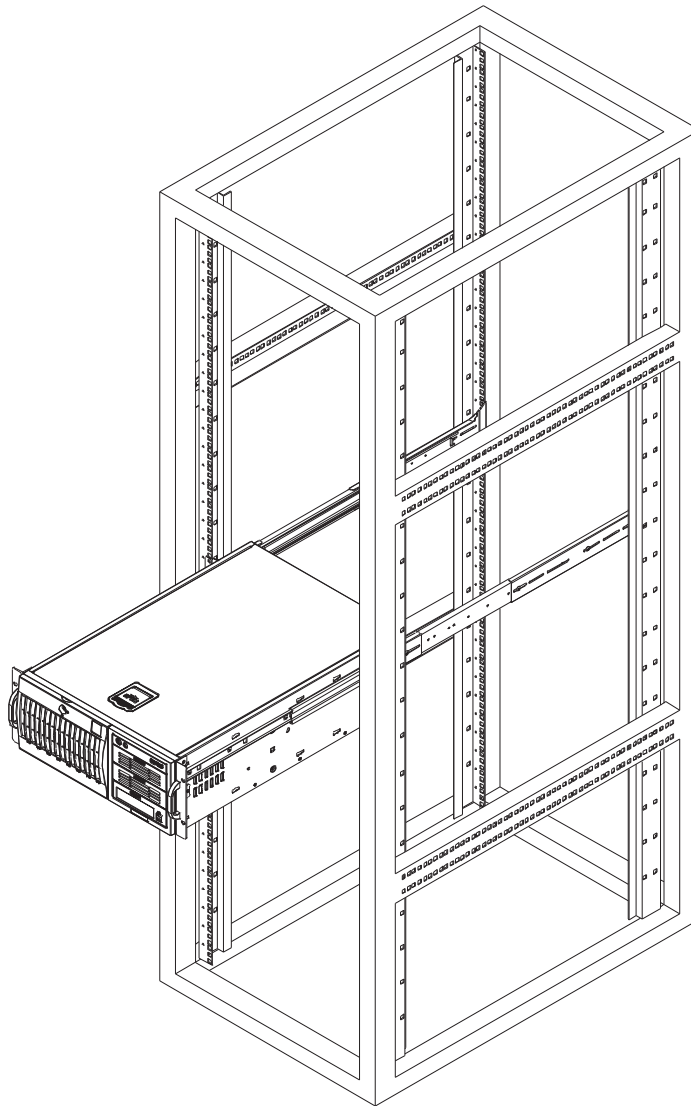

Notes

Chapter 3

System Interface

3-1 Overview

The control panel on the 7047A-73/7047A-T has several LEDs and two buttons. There are also two LEDs on each hard drive carrier. These LEDs keep you constantly informed of the overall status of the system and the activity and health of specific components.

3-2 Control Panel Buttons

There are two push-buttons located on the front of the chassis: a power on/off button and a reset button.

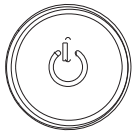

Power

This is the main power button, which is used to apply or turn off the main system power. Turning off system power with this button removes the main power but keeps standby power supplied to the system.



Reset

Use the reset button to reboot the system.

3-3 Control Panel LEDs

The control panel located on the front of the SC743TQ-1200B-SQ chassis has six LEDs that provide you with critical information related to different parts of the system. This section explains what each LED indicates when illuminated and any corrective action you may need to take.



Power

Indicates power is being supplied to the system's power supply. This LED should normally be on when the system is operating.

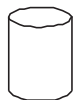

HDD

This LED indicates SAS (on the 7047A-73 only) or SATA drive activity when flashing.

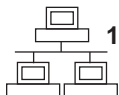

NIC1

Indicates network activity on LAN1 when flashing.



NIC2

Indicates network activity on LAN2 when flashing.

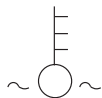

Overheat/Fan Fail

When this LED flashes, it indicates a chassis fan failure. When on continuously it indicates an overheat condition, which may be caused by cables obstructing the

airflow in the system or the ambient room temperature being too warm. Check the routing of the cables and make sure all fans are present and operating normally. You should also check to make sure that the chassis covers are installed. Finally, verify that the heatsinks are installed properly (see Chapter 5). This LED will remain flashing or on as long as the indicated condition exists.



Power Fail

Indicates a power supply fan has failed. The power supply module has a redundant backup fan that will increase its rpm to compensate, but the power module should be replaced as soon as it's convenient.

3-4 Drive Carrier LEDs

Note: the LEDs of some drive carriers may not function depending on the number of drives that are supported by the serverboard and/or backplane.

- **Green:** When illuminated, the green LED on the front of the hard drive carrier indicates drive activity. A connection to the drive backplane enables this LED to blink on and off when that particular drive is being accessed.
- **Red:** The backplane activates the red LED to indicate a drive failure. If one of the hard drives fail, you should be notified by your system management software. Please refer to Chapter 6 for instructions on replacing failed hard drives.

Notes

Chapter 4

System Safety

4-1 Electrical Safety Precautions



Basic electrical safety precautions should be followed to protect yourself from harm and the SuperWorkstation 7047A-73/7047A-T from damage:

- Be aware of the locations of the power on/off switch on the chassis as well as the room's emergency power-off switch, disconnection switch or electrical outlet. If an electrical accident occurs, you can then quickly remove power from the system.
- Do not work alone when working with high voltage components.
- Power should always be disconnected from the system when removing or installing main system components, such as the serverboard, memory modules and the DVD-ROM and floppy drives. When disconnecting power, you should first power down the system with the operating system. The unit has more than one power supply cord. Disconnect both power supply cords before servicing to avoid electrical shock.
- When working around exposed electrical circuits, another person who is familiar with the power-off controls should be nearby to switch off the power if necessary.
- Use only one hand when working with powered-on electrical equipment. This is to avoid making a complete circuit, which will cause electrical shock. Use extreme caution when using metal tools, which can easily damage any electrical components or circuit boards they come into contact with.
- Do not use mats designed to decrease electrostatic discharge as protection from electrical shock. Instead, use rubber mats that have been specifically designed as electrical insulators.
- The power supply power cord must include a grounding plug and must be plugged into grounded electrical outlets.

- Serverboard Battery: **CAUTION** - There is a danger of explosion if the onboard battery is installed upside down, which will reverse its polarities (see Figure 4-1). This battery must be replaced only with the same or an equivalent type recommended by the manufacturer (CR2032). Dispose of used batteries according to the manufacturer's instructions.
- DVD-ROM Laser: **CAUTION** - this server may have come equipped with a DVD-ROM drive. To prevent direct exposure to the laser beam and hazardous radiation exposure, do not open the enclosure or use the unit in any unconventional way.
- Mainboard replaceable soldered-in fuses: Self-resetting PTC (Positive Temperature Coefficient) fuses on the mainboard must be replaced by trained service technicians only. The new fuse must be the same or equivalent as the one replaced. Contact technical support for details and support.

4-2 General Safety Precautions



Follow these rules to ensure general safety:

- Keep the area around the SuperWorkstation 7047A-73/7047A-T clean and free of clutter.
- The 7047A-73/7047A-T weighs approximately 64 lbs (29.1 kg.) when fully loaded. When lifting the system, two people at either end should lift slowly with their feet spread out to distribute the weight. Always keep your back straight and lift with your legs. Don't use the handles (if installed) to lift the chassis; the handles should only be used to pull the server out of the rack.
- Place the chassis top cover and any system components that have been removed away from the system or on a table so that they won't accidentally be stepped on.
- While working on the system, do not wear loose clothing such as neckties and unbuttoned shirt sleeves, which can come into contact with electrical circuits or be pulled into a cooling fan.
- Remove any jewelry or metal objects from your body, which are excellent metal conductors that can create short circuits and harm you if they come into contact with printed circuit boards or areas where power is present.

- After accessing the inside of the system, close the system back up and secure it to the rack unit with the retention screws after ensuring that all connections have been made.

4-3 ESD Precautions



Electrostatic discharge (ESD) is generated by two objects with different electrical charges coming into contact with each other. An electrical discharge is created to neutralize this difference, which can damage electronic components and printed circuit boards. The following measures are generally sufficient to neutralize this difference before contact is made to protect your equipment from ESD:

- Use a grounded wrist strap designed to prevent static discharge.
- Keep all components and printed circuit boards (PCBs) in their antistatic bags until ready for use.
- Touch a grounded metal object before removing the board from the antistatic bag.
- Do not let components or PCBs come into contact with your clothing, which may retain a charge even if you are wearing a wrist strap.
- Handle a board by its edges only; do not touch its components, peripheral chips, memory modules or contacts.
- When handling chips or modules, avoid touching their pins.
- Put the serverboard and peripherals back into their antistatic bags when not in use.
- For grounding purposes, make sure your computer chassis provides excellent conductivity between the power supply, the case, the mounting fasteners and the serverboard.

4-4 Operating Precautions



Care must be taken to assure that the chassis cover is in place when the system is operating to assure proper cooling. Out of warranty damage to the system can occur if this practice is not strictly followed.

Figure 4-1. Installing the Onboard Battery

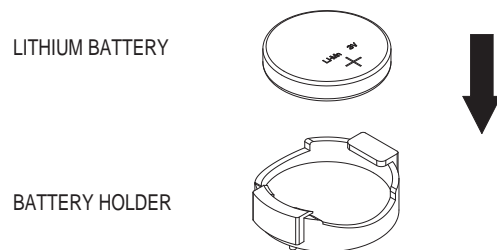

Please handle used batteries carefully. Do not damage the battery in any way; a damaged battery may release hazardous materials into the environment. Do not discard a used battery in the garbage or a public landfill. Please comply with the regulations set up by your local hazardous waste management agency to dispose of your used battery properly.

Chapter 5

Advanced Serverboard Setup

This chapter covers the steps required to install the X9DA7/X9DAi serverboard into the chassis, connect the data and power cables and install add-on cards. All serverboard jumpers and connections are also described. A layout and quick reference chart are included in this chapter for your reference. Remember to completely close the chassis when you have finished working with the serverboard to better cool and protect the system.

5-1 Handling the Serverboard

Electrostatic discharge (ESD) can damage electronic components. To prevent damage to any printed circuit boards (PCBs), it is important to handle them very carefully (see previous chapter). To prevent the serverboard from bending, keep one hand under the center of the board to support it when handling. The following measures are generally sufficient to protect your equipment from electric static discharge.

Precautions

- Use a grounded wrist strap designed to prevent Electrostatic Discharge.
- Touch a grounded metal object before removing any board from its antistatic bag.
- Handle a board by its edges only; do not touch its components, peripheral chips, memory modules or gold contacts.
- When handling chips or modules, avoid touching their pins.
- Put the serverboard, add-on cards and peripherals back into their antistatic bags when not in use.
- For grounding purposes, make sure your computer chassis provides excellent conductivity between the power supply, the case, the mounting fasteners and the serverboard.

Unpacking

The serverboard is shipped in antistatic packaging to avoid electrical static discharge. When unpacking the board, make sure the person handling it is static protected.

5-2 Serverboard Installation

This section explains the first step of physically mounting the X9DA7/X9DAi into the SC743TQ-1200B-SQ chassis. Following the steps in the order given will eliminate the most common problems encountered in such an installation. To remove the serverboard, follow the procedure in reverse order.

Installing to the Chassis

1. Access the inside of the system by removing the screws from the back lip of the top cover of the chassis, then pull the cover off.
2. Make sure that the I/O ports on the serverboard align properly with their respective holes in the I/O shield at the back of the chassis.
3. Carefully mount the serverboard to the serverboard tray by aligning the board holes with the raised metal standoffs that are visible in the chassis.
4. Insert screws into all the mounting holes on your serverboard that line up with the standoffs and tighten until snug (if you screw them in too tight, you might strip the threads). Metal screws provide an electrical contact to the serverboard ground to provide a continuous ground for the system.
5. Finish by replacing the top cover of the chassis.

Warning: To avoid damaging the serverboard and its components, do not apply any force greater than 8 lbs. per square inch when installing a screw into a mounting hole.

5-3 Connecting Cables

Now that the serverboard is installed, the next step is to connect the cables to the board. These include the data (ribbon) cables for the peripherals and control panel and the power cables.

Connecting Data Cables

The cables used to transfer data from the peripheral devices have been carefully routed to prevent them from blocking the flow of cooling air that moves through the system from front to back. If you need to disconnect any of these cables, you should take care to keep them routed as they were originally after reconnecting them (make sure the red wires connect to the pin 1 locations). The following data cables (with their locations noted) should be connected. (See the layout on page 5-9 for connector locations.)

- SAS drive data cables (SAS0 ~ SAS7, 7047A-73 only)
- SATA drive data cables (I-SATA0 ~ I-SATA5; 7047A-T only)
- Control Panel cable (JF1)
- SGPIO cable (T-SGPIO1, T-SGPIO2; 7047A-T only)

Important! Make sure the the cables do not come into contact with the fans.

Connecting Power Cables

The X9DA7/X9DAi has a 24-pin primary power supply connector (J22) for connection to the ATX power supply. In addition, two 8-pin secondary power connectors (JPWR1 and JPWR2) must also be connected to your power supply. See Section 5-9 for power connector pin definitions.

Connecting the Control Panel

JF1 contains header pins for various front control panel connectors. See Figure 5-1 for the pin locations of the various front control panel buttons and LED indicators.

All JF1 wires have been bundled into a single ribbon cable to simplify this connection. Make sure the red wire plugs into pin 1 as marked on the board. The other end connects to the Control Panel PCB board, located just behind the system status LEDs on the chassis. See Chapter 5 for details and pin descriptions.

Figure 5-1. Control Panel Header Pins

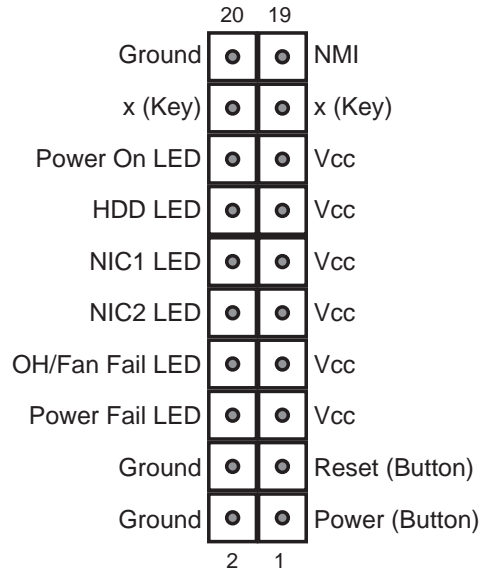

5-4 I/O Ports

The I/O ports are color coded in conformance with the PC 99 specification. See Figure 5-2 below for the colors and locations of the various I/O ports.

Figure 5-2. I/O Ports

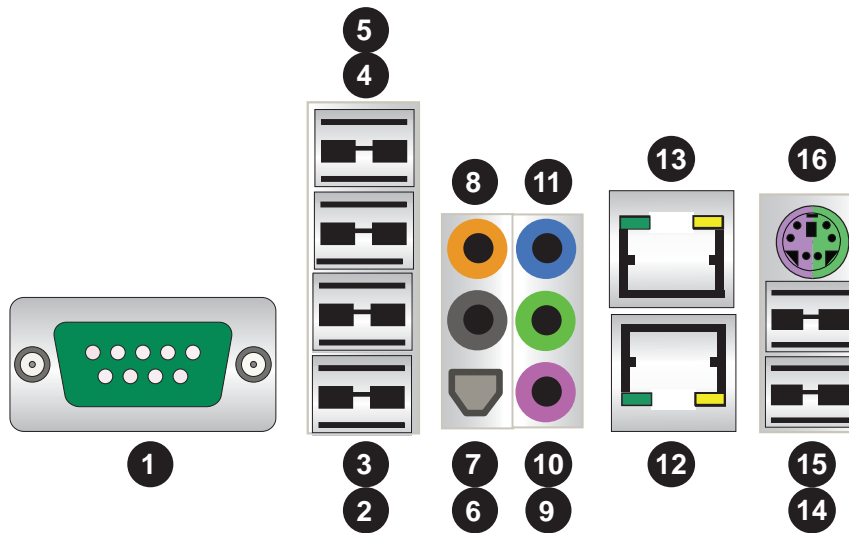

1. COM1 Port (Turquoise)	9. MIC In
2. USB 2.0 Port 0	10. Line Out
3. USB 2.0 Port 1	11. Line In
4. USB 2.0 Port 2	12. Gb LAN 1 Port
5. USB 2.0 Port 2	13. CGb LAN 2 Port
6. SPDIF Out	14. USB 3.0 Port 0 (or USB keyboard/mouse)
7. Surround Out	15. USB 3.0 Port 1 (or USB keyboard/mouse)
8. CEN/LFE Out	16. PS/2 Keyboard or Mouse

5-5 Processor and Heatsink Installation



When handling the processor package, avoid placing direct pressure on the label area of the fan.

Notes:

- Always connect the power cord last and always remove it before adding, removing or changing any hardware components. Make sure that you install the processor into the CPU socket before you install the CPU heatsink.
- If you buy a CPU separately, make sure that you use an Intel-certified multi-directional heatsink only.
- Make sure to install the serverboard into the chassis before you install the CPU heatsinks.
- When receiving a serverboard without a processor pre-installed, make sure that the plastic CPU socket cap is in place and none of the socket pins are bent; otherwise, contact your retailer immediately.
- Refer to the Supermicro web site for updates on CPU support.

Installing an LGA 2011 Processor

1. There are two levers on the LGA2011 socket. First press and release the load lever labeled 'Open 1st'.
2. Press the second load lever labeled 'Close 1st' to release the load plate from its locked position.

Press down on the lever labeled 'Close 1st'

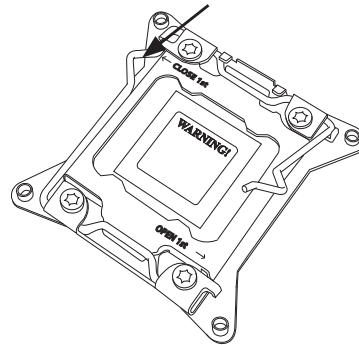

Pull lever away from the socket

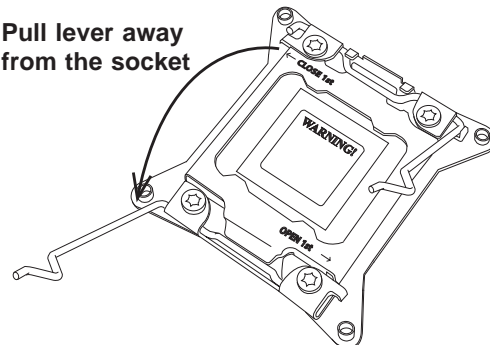

3. With the lever labeled 'Close 1st' fully retracted, gently push down on the 'Open 1st' lever to open the load plate. Lift the load plate to open it completely.
4. Using your thumb and the index finger, remove the 'WARNING' plastic cap from the socket.
5. Use your thumb and index finger to hold the CPU by its edges. Align the CPU keys, which are semi-circle cutouts, against the socket keys.
6. Once they are aligned, carefully lower the CPU straight down into the socket. (Do not drop the CPU on the socket. Do not move the CPU horizontally or vertically and do not rub the CPU against any pins of the socket, which may damage the CPU or the socket.)

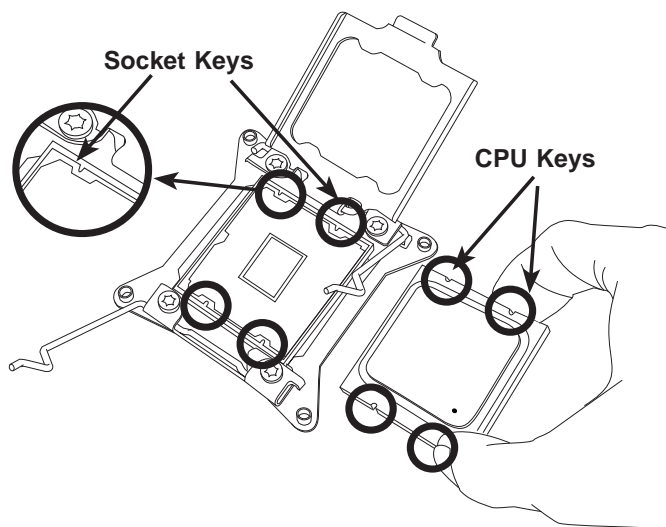
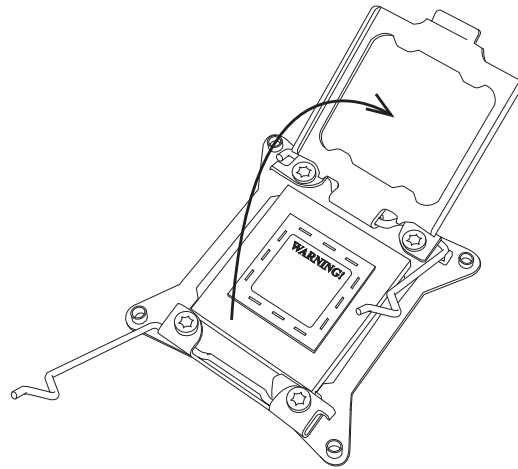
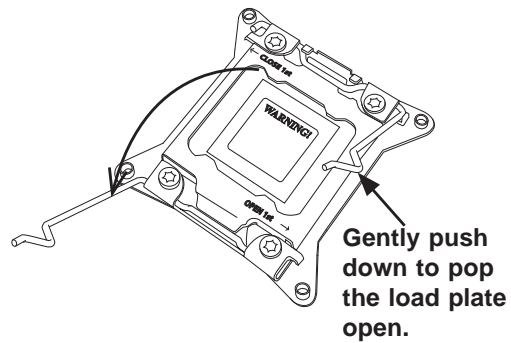



Warning: You can only install the CPU to the socket in one direction. Make sure that the CPU is properly inserted into the socket before closing the load plate. If it doesn't close properly, do not force it as it may damage your CPU. Instead, open the load plate again and double-check that the CPU is aligned properly.

7. With the CPU in the socket, inspect the four corners of the CPU to make sure that they are flush with the socket.
8. Close the load plate. Lock the lever labeled 'Close 1st', then lock the lever labeled 'Open 1st'. Use your thumb to gently push the load levers down until the lever locks.

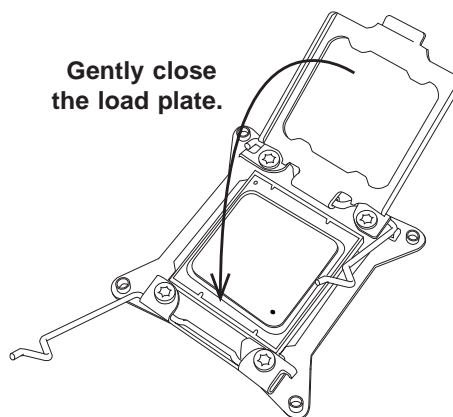

Push down and lock the level labeled 'Close 1st'.

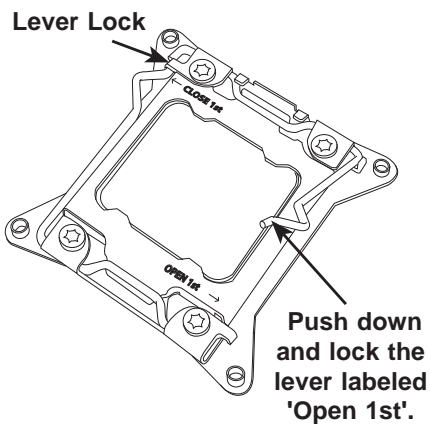
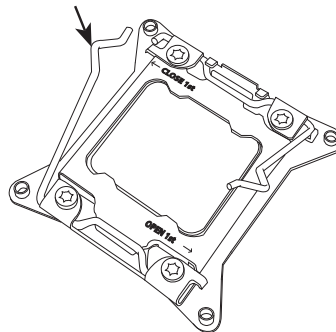

Installing a CPU Heatsink

1. Do not apply any thermal grease to the heatsink or the CPU die; the required amount has already been applied.
2. Place the heatsink on top of the CPU so that the four mounting holes are aligned with those on the serverboard and the heatsink bracket underneath.
3. Screw in two diagonal screws (i.e., the #1 and the #2 screws) until just snug. (To avoid possible damage to the CPU do not over-tighten the screws.)
4. Finish the installation by fully tightening all four screws.

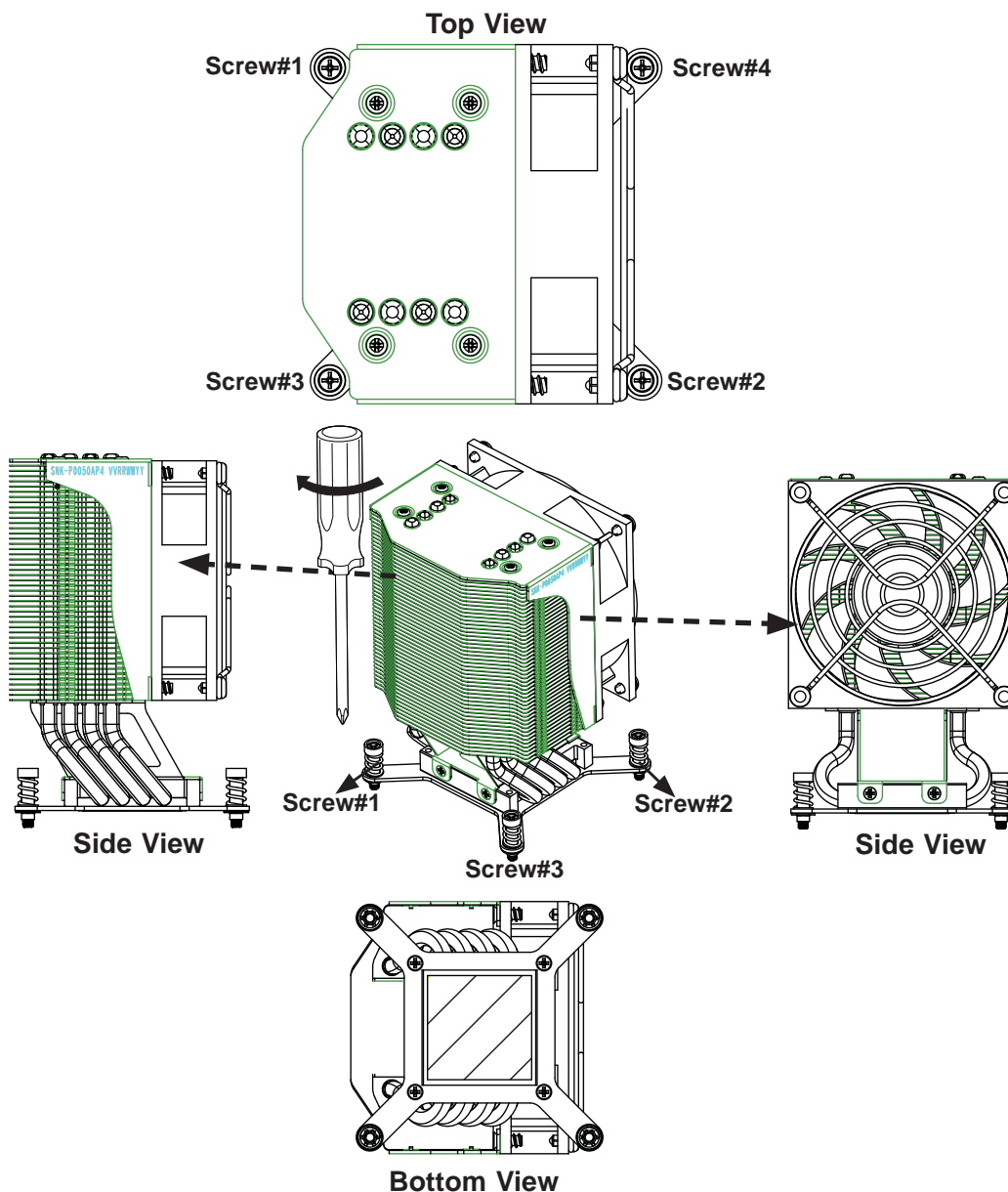

Removing the Heatsink



Warning: We do not recommend that the CPU or the heatsink be removed. However, if you do need to uninstall the heatsink, please follow the instructions below to uninstall the heatsink to prevent damage done to the CPU or the CPU socket.

1. Unscrew the heatsink screws from the serverboard in the sequence as shown in the illustration below.
2. Gently wriggle the heatsink to loosen it from the CPU. (Do not use excessive force when wriggling the heatsink!)
3. Once the heatsink is loosened, remove it from the CPU socket.
4. Remove the used thermal grease and clean the surface of the CPU and the heatsink, Reapply the proper amount of thermal grease on the surface before reinstalling the heatsink.

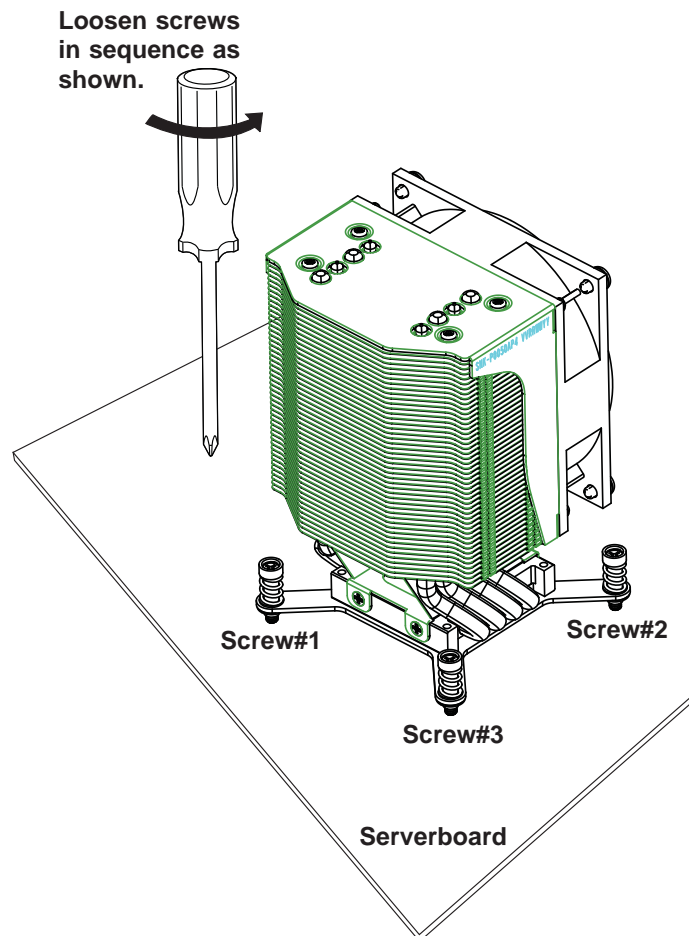

5-6 Installing Memory Modules

Note: Check the Supermicro web site for recommended memory modules.

CAUTION

Exercise extreme care when installing or removing DIMM modules to prevent any possible damage.

Installing & Removing DIMMs

1. Insert the desired number of DIMMs into the memory slots, starting with P1 DIMM1A. For best performance, please use the memory modules of the same type and speed in the same bank. See the DIMM Installation Chart on the following page.
2. Press down the release tabs on the ends of a memory slot. Insert each DIMM module vertically into its slot. Pay attention to the notch along the bottom of the module to prevent inserting the DIMM module incorrectly.
3. Using both thumbs, gently press down on the DIMM module until it snaps into place in the slot. Repeat for all modules.
4. Reverse the steps above to remove the DIMM modules from the serverboard.

Press down the release tabs

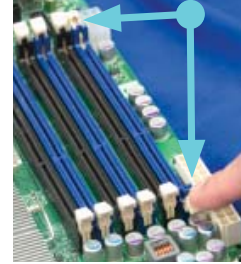

Insert & press a DIMM into the slot

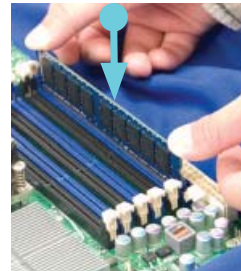
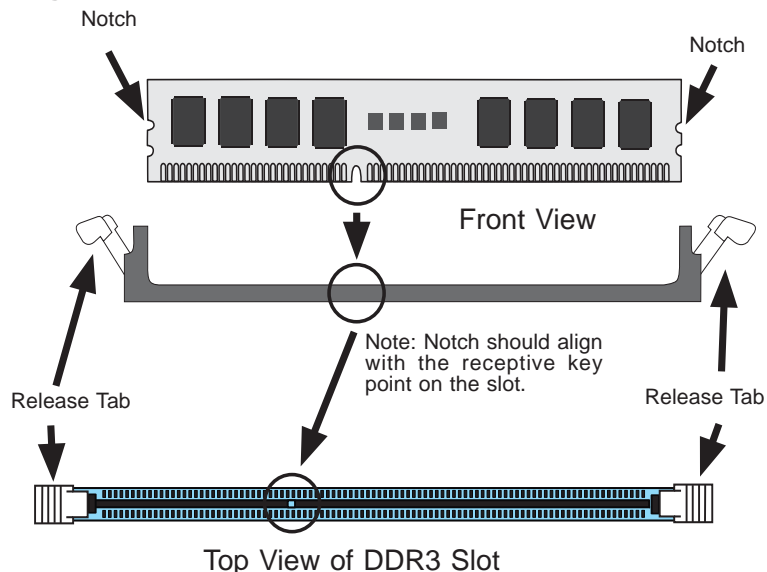

Figure 5-3. DIMM Installation

To Install: Insert module vertically and press down until it snaps into place. Pay attention to the alignment notch at the bottom.

To Remove: Use your thumbs to gently push the release tabs near both ends of the module. This should release it from the slot.



Memory Support

The X9DA7/X9DAi supports up to 512 GB of registered/unbuffered load reducing ECC DDR3-1600/1333/1066/833 memory in 16 DIMM slots. For the latest memory updates, please refer to the product page on the Supermicro website.

Order of Populating DIMM Slots

For memory to work properly, follow the table below for the correct order of populating the DIMM slots. See the serverboard layout page for slot numbering.

Notes: an "X" indicates a slot populated with a memory module.

Populate the "A" DIMM slots first. Any of the slots may be used. Populate the "B" slots only after all "A" slots have been filled.

Processors and their Corresponding DIMM Slots								
CPU#	Corresponding DIMM Modules							
CPU 1	P1-A1	P1-B1	P1-C1	P1-D1	P1-A2	P1-B2	P1-C2	P1-D2
CPU 2	P2-E1	P2-F1	P2-G1	P4-H1	P2-E2	P2-F2	P2-G2	P2-H2

Processor and Memory Module Population	
Number of CPUs+DIMMs	CPU and Memory Population Configuration Table (For memory to work proper, please install DIMMs in pairs.)
1 CPU & 2 DIMMs	CPU1 P1-A1/P1-B1
1 CPU & 4 DIMMs	CPU1 P1-A1/P1-B1, P1-C1/P1-D1
1 CPU & 5-8 DIMMs	CPU1 P1-A1/P1-B1, P1-C1/P1-D1 + Any memory pairs in P1-A2/-B2/-C2/-D2 DIMM slots
2 CPUs & 4 DIMMs	CPU1 + CPU2 P1-A1/P1-B1, P2-E1/P2-F1
2 CPUs & 6 DIMMs	CPU1 + CPU2 P1-A1/P1-B1/ P1-C1, P2-E1/P2-F1/P2-G1
2 CPUs & 8 DIMMs	CPU1 + CPU2 P1-A1/P1-B1/ P1-C1/P1-D1, P2-E1/P2-F1/P2-G1/P2-H1
2 CPUs & 10-16 DIMMs	CPU1/CPU2 P1-A1/P1-B1/ P1-C1/P1-D1/P1-A2, P2-E1/P2-F1/P2-G1/P2-H1+/P2-E2, Any memory pairs in P1, P2 DIMM slots

UDIMM Memory Support							
Ranks Per DIMM & Data Width	Memory Capacity Per DIMM (Note 1)			Speed (MT/s) and Voltage Validated by Slot Per Channel (SPC) and DIMM Per Channel (DPC) (Notes 2, 3, 4)			
				2 Slots Per Channel			
				1DPC		2DPC	
				1.35V	1.5V	1.35V	1.5V
SRx8 Non-ECC	1GB	2GB	4GB	n/a	1066, 1333	n/a	1066, 1333
DRx8 Non-ECC	2GB	4GB	8GB	n/a	1066, 1333	n/a	1066, 1333
SRx16 Non-ECC	512MB	1GB	2GB	n/a	1066, 1333	n/a	1066, 1333
SRx8 ECC	1GB	2GB	4GB	1066, 1333	1066, 1333	1066	1066, 1333
DRx8 ECC	2GB	4GB	8GB	1066, 1333	1066, 1333	1066	1066, 1333

Notes:

- 1Gb/2Gb/4Gb DRAMs are supported; however, only 2Gb and 4Gb DRAMs are validated.
- Command Address Timing is 1N for 1DPC and 2N for 2DPC.
- ES-4600 4S platforms do not support 3DPC UDIMMs.
- Please refer to the ES-4600 Platform Design Guide for memory population rules.

RDIMM Memory Support							
Ranks Per DIMM & Data Width	Memory Capacity Per DIMM (Note 1)			Speed (MT/s) and Voltage Validated by Slot Per Channel (SPC) and DIMM Per Channel (DPC) (Notes 2, 3, 4)			
				2 Slots Per Channel			
				1DPC		2DPC	
				1.35V	1.5V	1.35V	1.5V
SRx8	1GB	2GB	4GB	1066, 1333	1066, 1333	1066	1066, 1333
DRx8	2GB	4GB	8GB	1066, 1333	1066, 1333	1066	1066, 1333
SRx4	2GB	4GB	8GB	1066, 1333	1066, 1333	1066	1066, 1333
DRx4	4GB	8GB	16GB	1066, 1333	1066, 1333	1066	1066, 1333
QRx4	8GB	16GB	32GB	800	1066	800	800
QRx8	4GB	8GB	16GB	800	1066	800	800

Notes:

- 1Gb/2Gb/4Gb DRAMs are supported; however, only 2Gb and 4Gb DRAMs are validated.
- Command Address Timing is 1N.
- Please refer to the ES-4600 Platform Design Guide for memory population rules.
- QR RDIMMs are supported but not validated. Memory testing are limited to system level testing. Signal integrity testing in interoperability testing are not performed. The passing QR RDIMMs will be posted on the website.

LRDIMM Memory Support				
Ranks Per DIMM & Data Width (Note 1)	Memory Capacity Per DIMM (Note 2)		Speed (MT/s) and Voltage Validated by Slot Per Channel (SPC) and DIMM Per Channel (DPC) (Notes 3, 4, 5, 6)	
			2 Slots Per Channel	
			1DPC/2DPC	
			1.35V	1.5V
QRx4 (DDP) (Note 7)	16GB	32GB	1066	1066, 1333
QRx8 (P) (Note 8)	8GB	16GB	1066	1066, 1333
Notes: 1. Physical Rank is used to calculate DIMM capacity. 2. Command Address Timing is 1N. 3. Only 2Gb/4Gb DRAMs are supported and validated. 4. The speeds listed are estimated only and will be verified through simulation. 5. Please refer to the ES-4600 Platform Design Guide for memory population rules. 6. For 3SPC/3DPC-Rank Multiplication (RM) is ≥ 2 . 7. DDP is for Dual Die Package DRAM stacking. 8. "P" Means "Planer Monolithic DRAM Die."				

Notes and Restrictions

- For the memory modules to work properly, please install DIMM modules in pairs (with an even number of DIMMs installed).
- All channels in a system will run at the fastest common frequency.

DIMM Population Table				
DIMM Slots per Channel	DIMMs Populated per Channel	DIMM Type (Reg.= Registered)	Speeds (in MHz)	Ranks per DIMM (any combination; SR=Single Rank, DR=Dual Rank, QR=Quad Rank)
2	1	Reg. DDR3 ECC	800,1066,1333	SR, DR
2	1	Reg. DDR3 ECC	800,1066,	QR
2	2	Reg. DDR3 ECC	800,1066,1333	SR, DR
2	2	Reg. DDR3 ECC	800,1066	SR, DR, QR

Note 1: Due to OS limitations, some operating systems may not show more than 4 GB of memory.

Note 2: Due to memory allocation to system devices, the amount of memory that remains available for operational use will be reduced when 4 GB of RAM is used. The reduction in memory availability is disproportional. (See the following Memory Availability Table.)

Possible System Memory Allocation & Availability		
System Device	Size	Physical Memory Remaining (with 4 GB of system memory installed)
Firmware Hub flash memory (System BIOS)	1 MB	3.99 GB
Local APIC	4 KB	3.99 GB
Area Reserved for the chipset	2 MB	3.99 GB
I/O APIC (4 Kbytes)	4 KB	3.99 GB
PCI Enumeration Area 1	256 MB	3.76 GB
PCI Express (256 MB)	256 MB	3.51 GB
PCI Enumeration Area 2 (if needed) -Aligned on 256-MB boundary-	512 MB	3.01 GB
VGA Memory	16 MB	2.85 GB
TSEG	1 MB	2.84 GB
Memory available for the OS & other applications		2.84 GB

5-7 Adding PCI Add-On Cards

The 7047A-73/7047A-T can accommodate standard size add-on cards populated in all slots on the X9DA7/X9DAi serverboard.

Installing an Add-on Card

1. Begin by removing the PCI slot shield for the slot you wish to populate.
2. Fully seat the card into the card slot, pushing down with your thumbs evenly on both sides of the card.
3. Finish by using a screw to secure the top of the card shield to the chassis. The PCI slot shields protect the serverboard and its components from EMI and aid in proper ventilation, so make sure there is always a shield covering each unused slot.

X9DA7/X9DAi Quick Reference

Jumper	Description	Default Setting
JBT1	Clear CMOS	See Section 5-10
JP4	SMBus En/Disable	Pins 1-2 (Enabled)
JPI1	IEEE1394a En/Disable	Pins 1-2 (Enabled)
JPL1/2	GLAN1/GLAN2 En/Disable	Pins 1-2 (Enabled)
JPME1	ME Recovery	Pins 2-3 (Normal)
JPP0	JTAG Scan	Pins 2-3 (CPU 1 only)
JPP1	JTAG Scan	Pins 2-3 (CPU 2 only)
JWD	Watch Dog	Pins 1-2 (Reset)
JWP1	Write Protect Enable	Pins 1-2 (Enabled)

Connector	Description
7.1 Audio	8 Channel (7.1) High-Definition Backplane Audio Connector
BT1	Onboard Battery
CNF1/CNF2	IEEE 1394a 1/2 Connectors
COM1	Backplane COM Port1
FAN1~7, FANA	CPU/System Fan Headers (Fan6/Fan7: CPU 1/2 Fans)
I-SATA 0~5	LSI SATA Ports 0~5 (SATA 0/1 = SATA3, SATA2~5 = SATA 2)
J18	Audio Header
J22	ATX 24-Pin Power Connector
JD1	Speaker/Power LED Indicator
JF1	Front Panel Control Header
J ² C1	Power Supply SMBbus I ² C Header
JL1	Chassis Intrusion
JIPMI1	SIM_BMC Slot
JIPMB	4-pin External BMC I ² C Header (for an IPMI Card)
JPWR1/JPWR2	12V 8-Pin Power Connectors
JRK1	Option ROM Upgrade for the chipset
JRK2	RAIDKey (for X9DA7 only)
JSPDIF_In	SPDIF (Sony/Philips Digital Interface) In Header

Connector	Description
JSPDIF_Out	SPDIF (Sony/Philips Digital Interface) Out Header
JTPM1	TPM (Trusted Platform Module)/Port 80
JWF1	SATA DOM (Device On Module) Power Connector
LAN1/2	Gbit Ethernet Ports 1/2
SAS 0~3, 4~7	Serial Attached SCSI Ports 0~3, 4~7 (SAS 4~7 for X9DA7 only)
SP1	Onboard Buzzer (Internal Speaker)
STBY1	Standby Power Header
T-SGPIO 1/2	Serial-Link General_Purpose IO Headers
USB 2.0 0/1/2/3	Back Panel USB 2.0 Ports 0/1/2/3
USB 2.0 4, 5/6	Front Panel Accessible USB 2.0 Connections 4, 5/6
USB 3.0 0/1	Back Panel USB 3.0 Ports 0/1
USB 3.0 2/3	Front Panel Accessible USB 3.0 Connections 2/3

LED	Description	State	Status
LE1	Standby PWR LED	Green: On	SB Power On

5-9 Connector Definitions

Main ATX Power Supply Connector

The main power supply connector (J22) meets the SSI EPS 12V specification. Refer to the table on the right for the pin definitions of the ATX 24-pin power connector. You must also connect the 8-pin power connectors to your power supply (see below).

Main ATX Power Connector Pin Definitions (JPW3)			
Pin#	Definition	Pin #	Definition
13	+3.3V	1	+3.3V
14	-12V	2	+3.3V
15	COM	3	COM
16	PS_ON	4	+5V
17	COM	5	COM
18	COM	6	+5V
19	COM	7	COM
20	Res (NC)	8	PWR_OK
21	+5V	9	5VSB
22	+5V	10	+12V
23	+5V	11	+12V
24	COM	12	+3.3V



Warning: To prevent damage to the power supply or serverboard, please use a power supply that contains a 24-pin and two 8-pin power connectors. Be sure to connect these to the 24-pin and the two 8-pin power connectors on your serverboard to supply adequate power to your system. Failure to do so will void the manufacturer warranty on the power supply and serverboard.

Processor Power Connectors

JPWR1 and JPWR2 must also be connected to the power supply to provide power for the processors. See the table on the right for pin definitions.

Processor Power Connectors Pin Definitions (JPW1/JPW2)	
Pins	Definition
1 - 4	Ground
5 - 8	+12V

Required Connection

Power Button

The connection for the power button is on pins 1 and 2 of JF1. The chassis power button should be connected here. See the table on the right for pin definitions.

Power Button Pin Definitions (JF1)	
Pin#	Definition
1	PW_ON
2	Ground

Reset Connector

The reset header is located on pins 3 and 4 of JF1. Attach the reset switch on the computer chassis to these pins. See the table on the right for pin definitions.

Reset Button Pin Definitions (JF1)	
Pin#	Definition
3	Reset
4	Ground

Overheat/Fan Fail LED (OH)

Connect an LED to pins 7 and 8 of JF1 to provide advanced warning of chassis overheating or fan failure. Refer to the table on the right for pin definitions.

OH/Fan Fail LED Pin Definitions (JF1)		OH/Fan Fail Indicator Status	
Pin#	Definition	State	Definition
7	Vcc	Off	Normal
8	Ground	On	Overheat
		Flash- ing	Fan Fail

NIC1 (GLAN) LED

The LED connections for the GB LAN port are on pins 11 and 12 of JF1. Attach an LED cable to display network activity. See the table on the right for pin definitions.

NIC1 LED Pin Definitions (JF1)	
Pin#	Definition
11	Vcc
12	Ground

HDD LED

The HDD LED connection is located on pins 13 and 14 of JF1. This LED is used to display all IDE and SATA activity. See the table on the right for pin definitions.

HDD LED Pin Definitions (JF1)	
Pin#	Definition
13	Vcc
14	HD Active

Power On LED

The Power On LED connector is located on pins 15 and 16 of JF1 (use JLED for a 3-pin connector). This connection is used to provide LED indication of power being supplied to the system. See the table on the right for pin definitions.

Power LED Pin Definitions (JF1)	
Pin#	Definition
15	5V Stby
16	Control

Chassis Intrusion

The Chassis Intrusion header is designated JL1. Attach an appropriate cable from the chassis to inform you of a chassis intrusion when the chassis is opened

Chassis Intrusion Pin Definitions (JL1)	
Pin#	Definition
1	Intrusion Input
2	Ground

Fan Headers

The X9DA7/X9DAi has eight fan headers, all of which are 4-pin fans. However, pins 1-3 of the fan headers are backward compatible with the traditional 3-pin fans. See the table on the right for pin definitions. The onboard fan speeds are controlled by Thermal Management (via Hardware Monitoring) under the Advanced Section in the BIOS. The default is disabled. When using Thermal Management setting, please use all 3-pin fans or all 4-pin fans.

Fan Header Pin Definitions (FAN1-8)	
Pin#	Definition
1	Ground (Black)
2	+12V (Red)
3	Tachometer
4	PWM Control

Internal Speaker

The Internal Speaker, located at SP1, can be used to provide audible indications for various beep codes. See the table on the right for pin definitions.

Internal Buzzer (SP1) Pin Definition		
Pin#	Definitions	
Pin 1	Pos. (+)	Beep In
Pin 2	Neg. (-)	Alarm Speaker

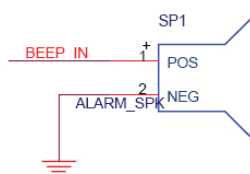

Power LED/Speaker

On JD1 header, pins 1-3 are used for power LED indication, and pins 4-7 are for the speaker. See the tables on the right for pin definitions. Please note that the speaker connector pins (4-7) are used with an external pins. If you wish to use the on-board speaker, you should close pins 6-7 with a jumper.

PWR LED Connector Pin Definitions	
Pin Setting	Definition
Pin 1	Anode (+)
Pin2	Cathode (-)
Pin3	NA

Speaker Connector Pin Settings	
Pin Setting	Definition
Pins 4-7	External Speaker
Pins 6-7	Internal Speaker

TPM Header/Port 80

A Trusted Platform Module/Port 80 header is located at JTPM1 to provide TPM support and Port 80 connection. Use this header to enhance system performance and data security. See the table on the right for pin definitions.

TPM/Port 80 Header Pin Definitions			
Pin #	Definition	Pin #	Definition
1	LCLK	2	GND
3	LFRAME#	4	<(KEY)>
5	LRESET#	6	+5V (X)
7	LAD 3	8	LAD 2
9	+3.3V	10	LAD1
11	LAD0	12	GND
13	SMB_CLK4	14	SMB_DAT4
15	+3V_DUAL	16	SERIRQ
17	GND	18	CLKRUN# (X)
19	LPCPD#	20	LDRQ# (X)

Standby Power Header

The Standby Power header is located at STBY1 on the serverboard. See the table on the right for pin definitions.

Standby Power Pin Definitions	
Pin#	Definition
1	+5V Standby
2	Ground
3	Wake-up

Power SMB (I²C) Connector

Power System Management Bus (I²C) Connector (JI²C1) monitors power supply, fan and system temperatures. See the table on the right for pin definitions.

PWR SMB Pin Definitions	
Pin#	Definition
1	Clock
2	Data
3	PWR Fail
4	Ground
5	+3.3V

IPMB

A System Management Bus header for IPMI 2.0 is located at JIPMB. Connect the appropriate cable here to use the IPMB I²C connection on your system.

IPMB Header Pin Definitions	
Pin#	Definition
1	Data
2	Ground
3	Clock
4	No Connection

SGPIO Header

Two SGPIO (Serial General Purpose Input/Output) headers are designated T-SGPIO1 and SGPIO2. These headers are used to communicate with the system's enclosure management chip. See the table on the right for pin definitions.

SGPIO Header Pin Definitions			
Pin#	Definition	Pin	Definition
1	NC	2	NC
3	Ground	4	Data
5	Load	6	Ground
7	Clock	8	NC

NC = No Connection

IEEE 1394a_1/ 1394a_2 Connectors

1394a_1 (CNF1) and 1394a_2 (CNF2) provide the IEEE 1394a (Firewire) connections on the serverboard. Connect IEEE 1394 cables to the connectors for IEEE 1394a support. See the tables on the right for pin definitions.

1394_1 Pin Definitions			
Pin#	Definition	Pin#	Definition
1	PTPA0+	2	PTPA0-
3	GND	4	GND
5	PTPB0+	6	PTPB0-
7	PWR 1394a	8	PWR 1394a
		10	Shield GND

1394_2 Pin Definitions			
Pin#	Definition	Pin#	Definition
1	PTPA1+	2	PTPA1-
3	GND	4	GND
5	PTPB1+	6	PTPB1-
7	PWR 1394a	8	PWR 1394a
		10	Shield GND

JRK1/JRK2

The JRK1 header allows the Option ROM to upgrade the onboard chipset. JRK2 is a RAIDKey used to provide RAID support for system performance enhancement.

JRK1 Pin Definitions		JRK2 Pin Definitions	
Pin#	Definition	Pin#	Definition
1	Ground	1	Ground
2	Signal	2	Signal
3	Ground	3	Ground

DOM Power Connector

A power connector for SATA DOM (Disk On Module) devices is located at JWF1. Connect an appropriate cable here to provide power support for your DOM devices.

DOM PWR Pin Definitions	
Pin#	Definition
1	+5V
2	Ground
3	Ground

SPDIF_In/SPDIF_Out Headers

The SPDIF In (JSPDIF_In) and SPDIF Out (JSPDIF_Out) headers are located next to the LAN controller on the serverboard. Place a cap on each header for audio support. You will also need to have a cable to use each connection.

SPDIF_In Pin Definitions	
Pin#	Definition
1	S/PDIF_In
2	Ground

SPDIF_Out Pin Definitions	
Pin#	Definition
1	S/PDIF_Out
2	Ground

SIMBMC Slot

The SIM_BMC (Baseboard Management Control) slot is located at JIPMI1 on the serverboard. Insert an SMC proprietary SIM BMC add-on card for BMC support. You will also need to have a cable to use this connection.

5-10 Jumper Settings

Explanation of Jumpers

To modify the operation of the serverboard, jumpers can be used to choose between optional settings. Jumpers create shorts between two pins to change the function of the connector. Pin 1 is identified with a square solder pad on the printed circuit board. See the serverboard layout pages for jumper locations.

Note: On a two-pin jumper, "Closed" means the jumper is on both pins and "Open" means the jumper is either on only one pin or completely removed.

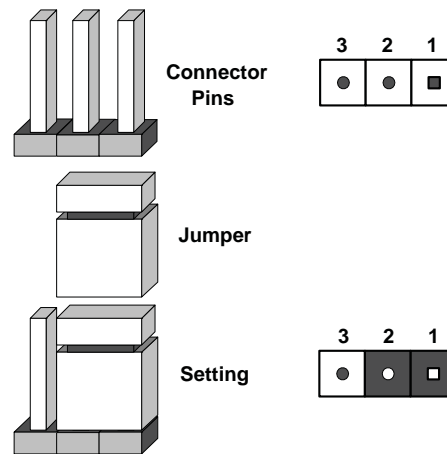

CMOS Clear

JBT1 is used to clear CMOS (which will also clear any passwords). Instead of pins, this jumper consists of contact pads to prevent accidentally clearing the contents of CMOS.

To clear CMOS,

1. First power down the system and unplug the power cord(s).
2. With the power disconnected, short the CMOS pads with a metal object such as a small screwdriver.
3. Remove the screwdriver (or shorting device).
4. Reconnect the power cord(s) and power on the system.

Note: Do not use the PW ON connector to clear CMOS.

GLAN Enable/Disable

Change the setting of jumper JPL1 or JPL2 to enable or disable the LAN1 and LAN2 Ethernet ports, respectively. See the table on the right for jumper settings. The default setting is enabled.

GLAN Jumper Settings	
Jumper Setting	Definition
1-2	Enabled (default)
2-3	Disabled

Watch Dog Enable/Disable

JWD controls the Watch Dog function. Watch Dog is a system monitor that can reboot the system when a software application hangs. Jumping pins 1-2 will cause WD to reset the system if an application hangs. Jumping pins 2-3 will generate a non-maskable interrupt signal for the application that hangs. See the table on the right for jumper settings. Watch Dog must also be enabled in BIOS.

Watch Dog Jumper Settings	
Jumper Setting	Definition
Pins 1-2	Reset (default)
Pins 2-3	NMI
Open	Disabled

IEEE 1394a Enable/Disable

JPI1 allows you to enable or disable the onboard IEEE 1394a (Firewire) support. The default position is on pins 1 and 2 to use the 1394_1 and 1394_2 connections. See the table on the right for jumper settings.

1394a Jumper Settings	
Both Jumpers	Definition
Pins 1-2	Enabled
Pins 2-3	Disabled

Write Protect Enable/Disable

Close pins 1/2 of jumper JWP1 to enable write protect support for system security and data integrity. See the table on the right for jumper settings.

WriteProtect Jumper Settings	
Jumper Setting	Definition
Pins 1/2	Write_Protect Enable (Default)
Pins 2/3	Write_Protect Disable

Manufacture Mode

Jumper JPME1 allows the user to flash the system firmware from a host server to modify system settings. Close this jumper to bypass SPI flash security, and force ME into recovery mode in order to use recovery jumpers. See the table on the right for jumper settings.

ME Mode Select Jumper Settings	
Jumper Setting	Definition
Pins 1-2	Manufacture Mode
Pins 2-3	Normal (Default)

JTAG Scan

The JTAG scan jumpers (JPP0/JPP1) allow the user to configure JTAG scan settings for system debugging. See the table on the right for jumper settings.

JTAG Scan (JPP0) Jumper Settings	
Jumper Setting	Definition
Pins 1/2, 3/4	including CPU2 in JTAG Scan
Pins 2/3 (Default)	JTAG Scan: CPU1 only

JTAG Scan (JPP1) Jumper Settings	
Jumper Setting	Definition
Pins 1/2, 3/4	including CPU1 in JTAG Scan
Pins 2/3 (Default)	JTAG Scan: CPU2 only

SMB Enable/Disable

Jumper JP4 allows the user to enable System Management Bus support. The default setting is 1-2 to enable support. See the table on the right for jumper settings.

SMB Jumper Settings	
Jumper Setting	Definition
1-2	Enabled (Default)
2-3	Disabled

5-11 Onboard Indicators

LAN1/2 LEDs

The Ethernet ports (located beside the VGA port) have two LEDs. On each port, one LED indicates activity while the other LED may be green, amber or off to indicate the speed of the connection. See the table on the right for the functions associated with the connection speed LED.

LAN1/2 LED (Connection Speed Indicator)	
LED Color	Definition
Off	No Connection or 10 Mb/s
Green	100 Mb/s
Amber	1 Gb/s

Onboard Power LED

An Onboard Power LED is located at LE1 on the serverboard. When this LED is on, the system is on. Be sure to turn off the system and unplug the power cord before removing or installing components. See the table at right for more information.

Onboard PWR LED Indicator (LE1) LED Definitions	
LED Color	Status
Off	System Off (PWR cable not connected)
Green	System On
Green: Flashing Quickly	ACPI S1 State
Green: Flashing Slowly	ACPI S3 (STR) State

5-12 SAS and SATA Ports

SATA Ports

Two SATA3 Ports (I-SATA0/1), colored in white, and four SATA2 Ports (I-SATA2~5) are located on the serverboard. These ports provide serial-link signal connections, which are faster than the connections of Parallel ATA. See the table on the right for pin definitions.

SATA Port Pin Definitions			
Pin#	Definition	Pin #	Definition
1	Ground	2	TXP
3	TXN	4	Ground
5	RXN	6	RXP
7	Ground		

SAS2 Ports

Eight SAS ports (SAS 0~3, 4~7) provide serial link connections on the serverboard. On the X9DAi, SAS 0~3 can function as SATA3 ports if the connector is used with the mini iPass cable included in the shipping package. The SAS 4~7 ports are available on the X9DA7 only. See the table on the right for pin definitions.

SAS Port Pin Definitions			
Pin#	Definition	Pin #	Definition
1	Ground	2	TXP
3	TXN	4	Ground
5	RXN	6	RXP
7	Ground		

5-13 Installing Software

After the hardware has been installed, you should first install the operating system and then the drivers. The necessary drivers are all included on the Supermicro CDs that came packaged with your serverboard.

Image will be place when available

Driver/Tool Installation Display Screen

Note: Click the icons showing a hand writing on paper to view the readme files for each item. Click the computer icons to the right of these items to install each item (from top to the bottom) one at a time. **After installing each item, you must re-boot the system before moving on to the next item on the list.** The bottom icon with a CD on it allows you to view the entire contents of the CD.

SuperDoctor III

The SuperDoctor® III program is a Web base management tool that supports remote management capability. It includes Remote and Local Management tools. The local management is called SD III Client. The SuperDoctor III program included on the CD-ROM that came with your serverboard allows you to monitor the environment and operations of your system. SuperDoctor III displays crucial system information such as CPU temperature, system voltages and fan status. See the Figure below for a display of the SuperDoctor III interface.

Note: The default User Name and Password for SuperDoctor III is ADMIN / ADMIN.

Note: When SuperDoctor is first installed, it adopts the temperature threshold settings that have been set in BIOS. Any subsequent changes to these thresholds must be made within SuperDoctor, as the SuperDoctor settings override the BIOS settings. To set the BIOS temperature threshold settings again, you would first need to uninstall SuperDoctor.

Supero Doctor III Interface Display Screen (Health Information)

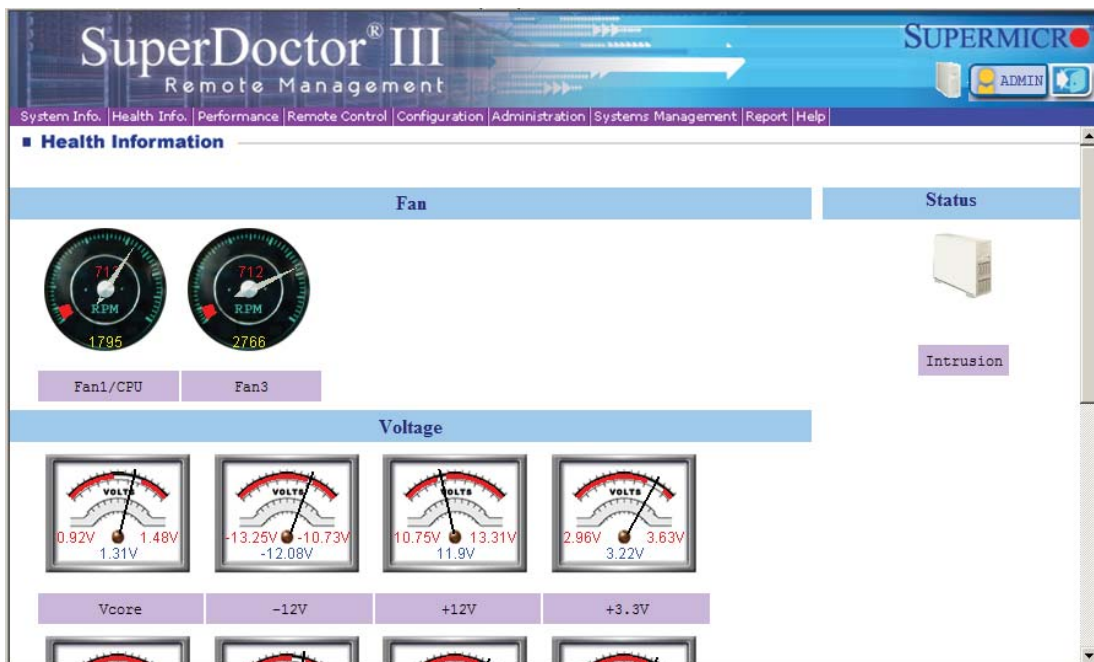

Supero Doctor III Interface Display Screen (Remote Control)

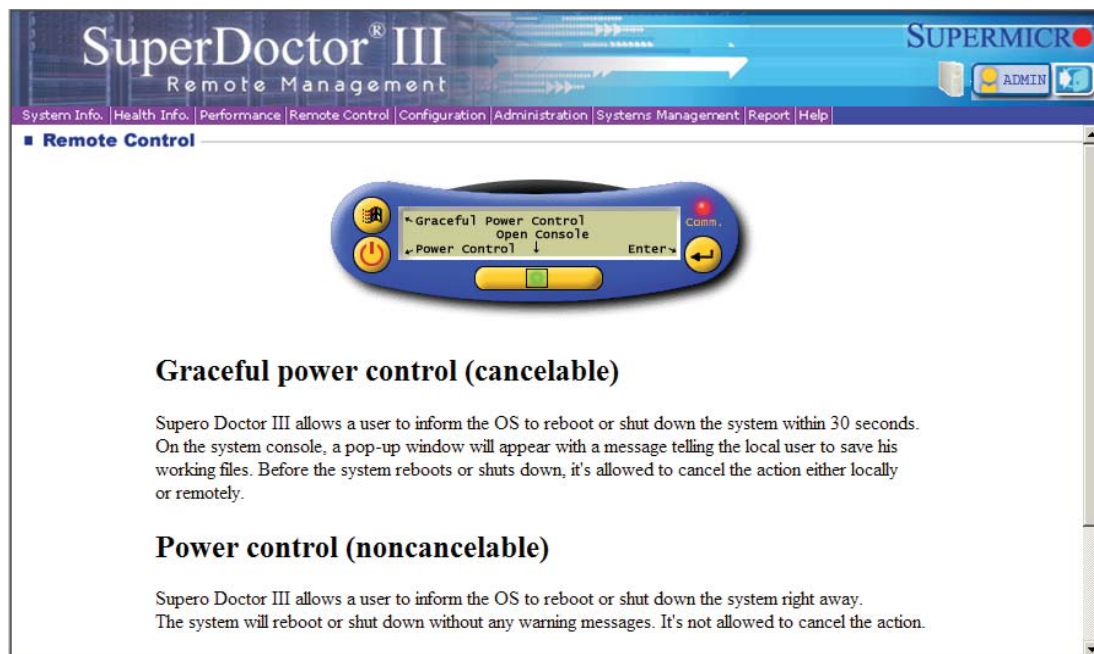

Note: The SuperDoctor III program and User's Manual can be downloaded from the Supermicro web site at <http://www.supermicro.com/products/accessories/software/SuperDoctorIII.cfm>.

For Linux, we recommend using SuperDoctor II.

Chapter 6

Advanced Chassis Setup

This chapter covers the steps required to install components and perform simple maintenance on the SC743TQ-1200B-SQ chassis. Following the component installation steps in the order given will eliminate most common problems. If some steps are unnecessary, skip ahead to the step that follows.

Tools Required: The only tool you will need is a Philips screwdriver.

6-1 Static-Sensitive Devices

Static electrical discharge can damage electronic components. To prevent damage to any printed circuit boards (PCBs), it is important to handle them very carefully. The following measures are generally sufficient to protect your equipment from static discharge.

Precautions

- Use a grounded wrist strap designed to prevent static discharge.
- Touch a grounded metal object before removing any board from its antistatic bag.
- Handle a board by its edges only; do not touch its components, peripheral chips, memory modules or gold contacts.
- When handling chips or modules, avoid touching their pins.
- Put the serverboard, add-on cards and peripherals back into their antistatic bags when not in use.
- For grounding purposes, make sure your computer chassis provides excellent conductivity between the power supply, the case, the mounting fasteners and the serverboard.

Unpacking

The serverboard is shipped in antistatic packaging. When unpacking the board, make sure the person handling it is static protected.

Figure 6-1. Chassis Front View

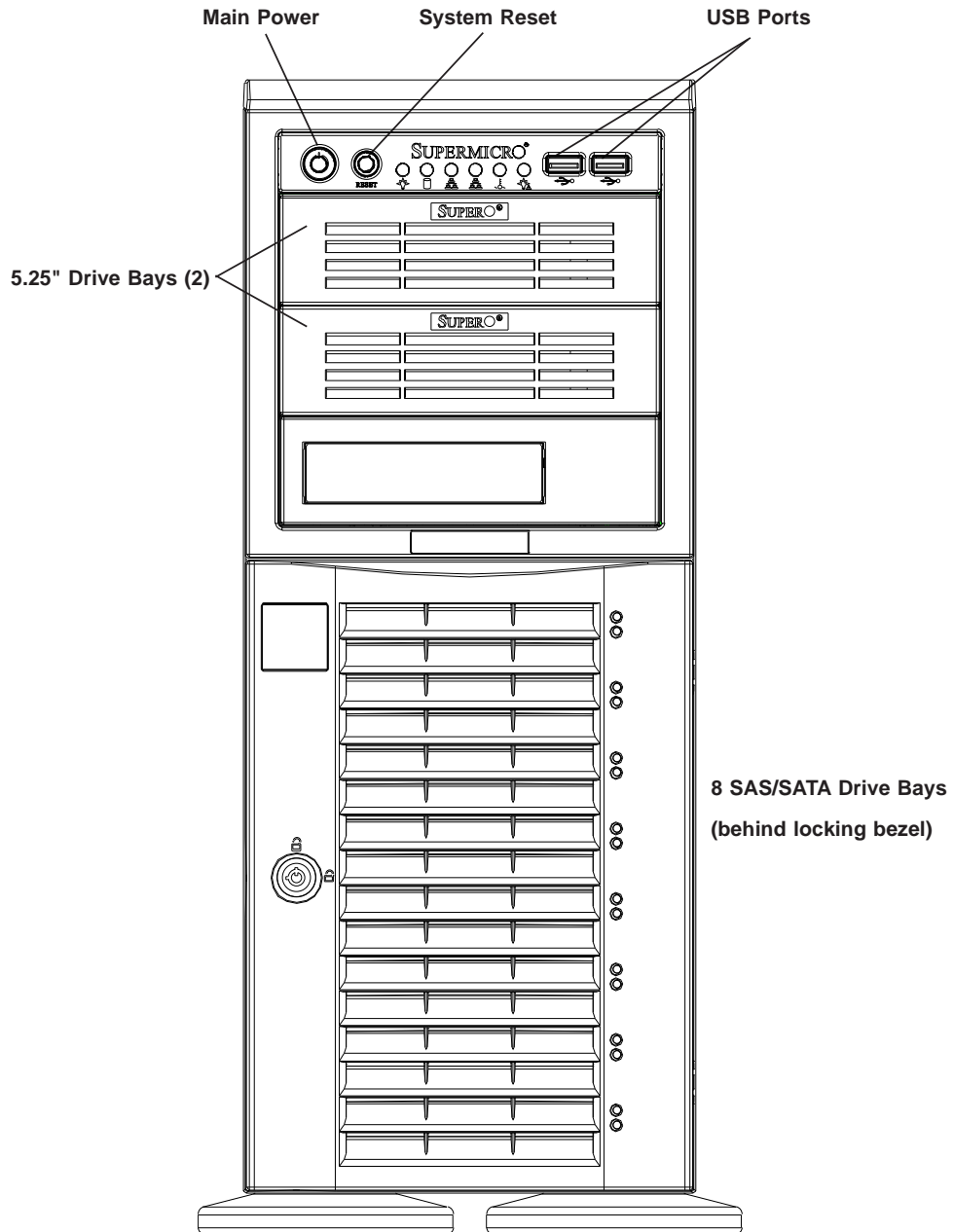







6-2 Front Control Panel

The front control panel must be connected to the JF1 connector on the serverboard to provide you with system status and alarm indications. A ribbon cable has bundled these wires together to simplify this connection.

Connect the cable from JF1 on the serverboard (making sure the red wire plugs into pin 1) to the appropriate connector on the front control panel PCB (printed circuit board). Pull all excess cabling over to the control panel side of the chassis. The LEDs on the control panel inform you of system status - see Figure 6-2 for details. See Chapter 5 for details on JF1.

Figure 6-2. Front Control Panel LEDs

Power		Indicates power is being supplied to the system.
HDD		Indicates IDE device and hard drive activity. On the SC743TQ-1200B-SQ, this LED indicates hard drive activity when flashing.
NIC1		Indicates network activity on LAN port 1.
NIC2		Indicates network activity on LAN port 2
Overheat/Fan Fail		When this LED flashes, it indicates a fan failure. When on continuously it indicates an overheat condition (see Chapter 3 for details).
Power Fail		Indicates a power supply fan failure. An alarm will also sound, which can be turned off with the reset switch on the back of the power supply.

6-3 System Fans

Two 8-cm PWM chassis fans provide air intake while one 9-cm PWM exhaust fan expels hot air from the chassis. All are low-noise fans that result in "Whisper-Quiet" operation (~28 dB). The fans should be connected to headers on the serverboard (see Chapter 5).

The power supply includes redundant cooling fans. If one fan fails, the remaining fan will ramp up its rpm to provide sufficient cooling. The Power Fail LED will illuminate and an audible alarm will sound, which can be silenced with a button on the power supply. If a power supply fan fails, you should replace the power supply at your earliest convenience.

Fan Failure

Under normal operation, the chassis fans, the exhaust fan and the power supply fans run continuously. The chassis fans are hot-pluggable and can be replaced without powering down the system.

Replacing Chassis Cooling Fans

Removing a Fan

1. First locate the failed chassis fan by removing the top/left chassis cover (see Chapter 2 for details). Locate the fan that has stopped working.
2. Depress the locking tab on the failed fan: on a chassis fan, push the tab on the side of the housing inward, on the exhaust fan push down on the colored tab.
3. With the tab depressed, pull the unit straight out (see Figure 6-3). The wiring for these fans has been designed to detach automatically.

Installing a New Fan

1. Replace the failed fan with an identical one (available from Supermicro)
2. Install it in the same position and orientation as the one you removed; it should click into place when fully inserted.
3. Check that the fan is working then replace the top/left side chassis panel.

Figure 6-3. Removing a Chassis Fan

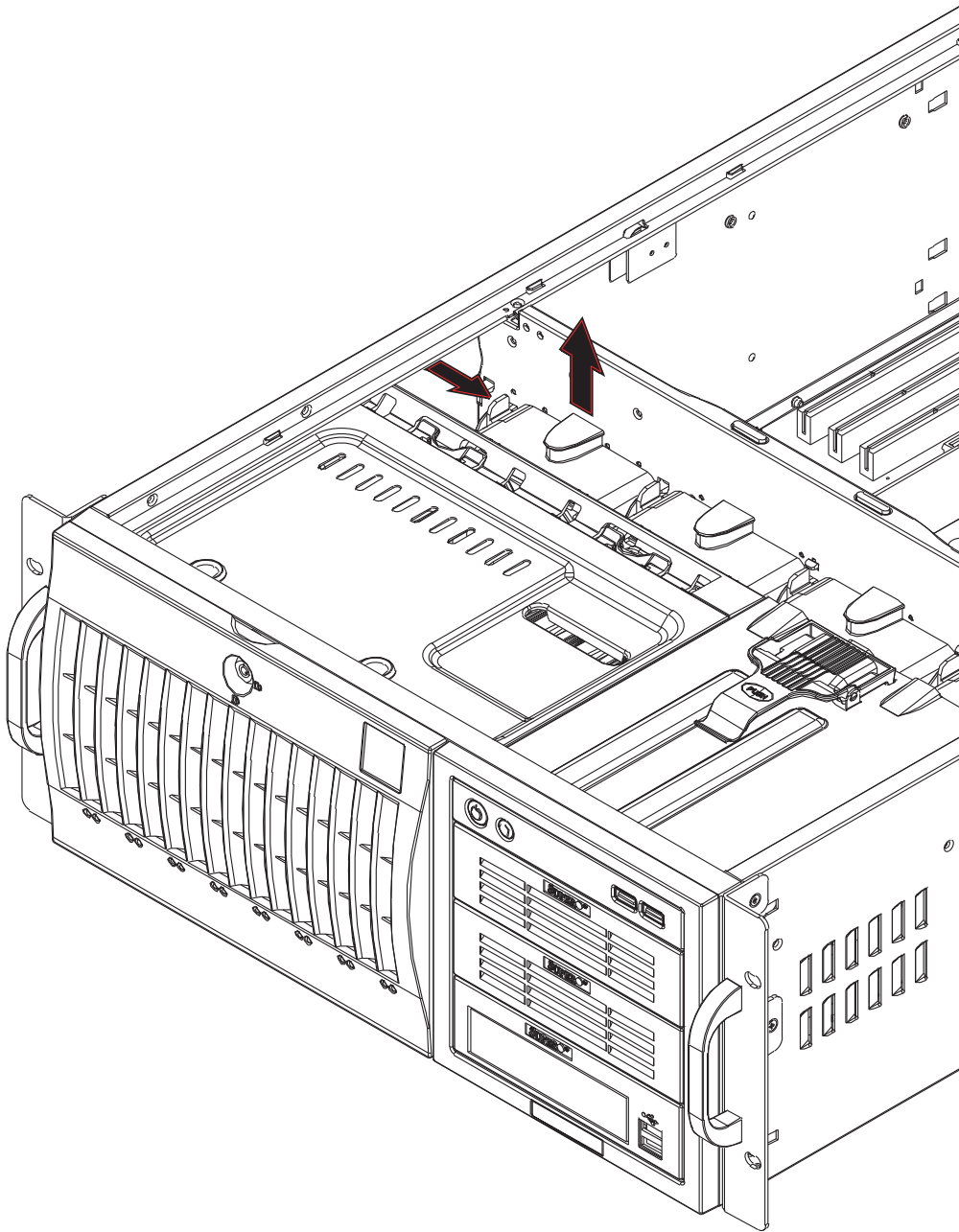

6-4 Drive Bay Installation

A total of six SAS or SATA drives may be housed in the SC743TQ-1200B-SQ chassis. The drive IDs are preconfigured as 0 through 7 in order from bottom to top (or from left to right if rackmounted). A bezel covers the drive area but does not need to be removed to access the drives; simply swing open the bezel. If you wish to remove the bezel piece, push on the three tabs on the inside of the left lip of the front chassis cover. Then slightly swing out the same (left) side of the cover - about ½ inch only. Remove by pushing on the open side of the cover to remove it from the chassis (do not try to swing or pull it straight out after opening the left side).



Regardless of how many SAS/SATA drives are installed, all drive carriers must remain in the drive bays to promote proper airflow.

Installing/Removing SAS/SATA Drives

The SAS/SATA drive carriers are all easily accessible at the front of the chassis. These drives are hot-swappable, meaning they can be removed and installed without powering down the system.

1. Open the front bezel then push the release button located beside the drive LEDs.
2. Swing the handle fully out and then use it to pull the unit straight out.

Note: Your operating system must have RAID support to enable the hot-swap capability of the SAS/SATA drives.

Mounting a SAS/SATA drive in a Drive Carrier

The SAS/SATA drive carriers help to promote proper airflow for the system. For this reason, even carriers without SAS/SATA drives must remain in the chassis.

1. Insert the drive into the carrier with the printed circuit board side facing down so that the mounting holes align with those in the carrier.
2. Secure the drive to the carrier with four screws (see Figure 6-5).



Enterprise level hard disk drives are recommended for use in Supermicro chassis and servers. For information on recommended HDDs, visit the Supermicro Web site at <http://www.supermicro.com/products/nfo/storage.cfm>

Figure 6-4. Removing a SAS/SATA Drive Carrier

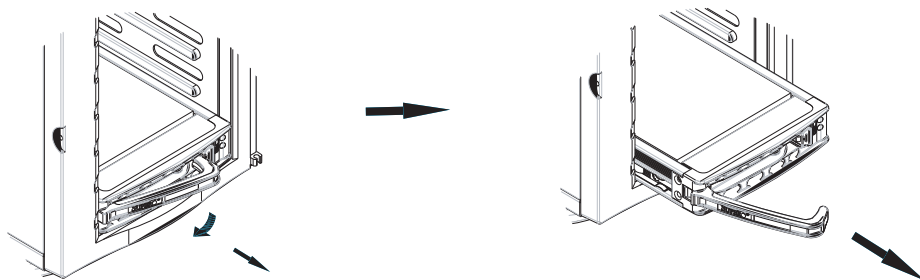
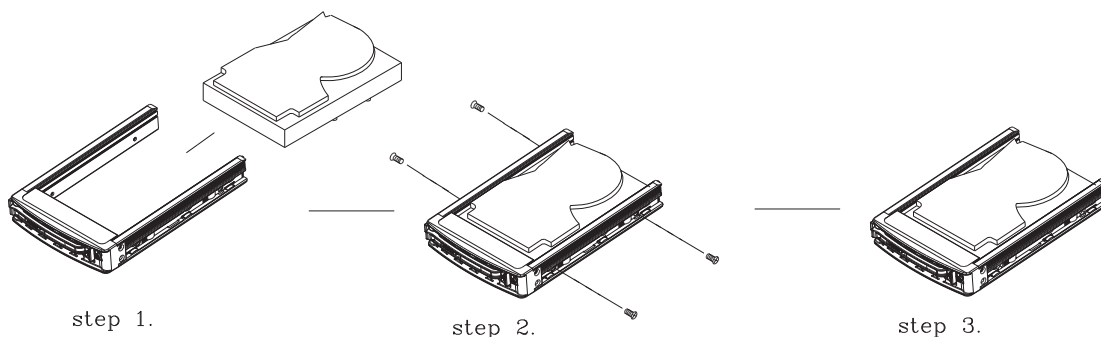

Figure 6-5. Mounting a SAS/SATA Drive in a Carrier



Important! Use extreme caution when working around the SAS/SATA backplane. Do not touch the backplane with any metal objects and make sure no ribbon cables touch the backplane or obstruct the airflow holes.

SAS/SATA Backplane

The SAS/SATA drives plug into a drive backplane. A data cable for each drive and two LED cables need to be connected from the serverboard to the appropriate connectors on the backplane.

You cannot cascade the SAS/SATA backplane.

Installing Components in the 5.25" Drive Bays

The 7047A-73/7047A-T has two 5.25" drive bays. Components such as an extra floppy drive or DVD/CD-ROM drives can be installed into these 5.25" drive bays.

Removing the Empty Drive Bay

1. First power down the system.
2. Remove the top/left chassis cover to access the drive components.
3. With the cover off, remove the screws that secure the drive carrier to the chassis (one side only) then push the entire empty drive carrier out from the back.

Adding a DVD/CD-ROM Drive

1. Remove the guide plates (one on each side) from the empty drive carrier and screw them into both sides of the DVD/CD-ROM drive using the holes provided.
2. Slide the DVD/CD-ROM into the bay and secure it to the chassis with the drive carrier screws you first removed.
3. Attach the power and data cables to the drive.
4. Replace the top/left chassis cover and restore power to the system.

6-5 Power Supply

The SuperWorkstation 7047A-73/7047A-T has a single 1200 watt power supply. This power unit is equipped with low-noise technology, making the system ideal for workstation environments.

The power supply has an auto-switching capability that enable it to automatically sense and operate with 100 or 240 volt inputs.

Power Supply Failure

If the power supply unit fails, the system will shut down and you will need to replace the power supply unit. Replace with the same model, which can be ordered directly from Supermicro. As there is only one power supply unit, the system must be powered down before removing and/or replacing the power supply for whatever reason.

Replacing the Power Supply

1. First power down the system.
2. Unplug the power cord from the power supply module.
3. Remove the screws that secure the module to the chassis then pull it completely out.
4. Replace the failed unit with another unit of the exact same part number.
5. Gently but firmly push the new unit all the way into the open bay.
6. Secure it to the chassis using the screws you previously removed.
7. Finish by replacing the chassis left/top cover and then plugging the power cord back into the new module you just added.
8. Push the power button to restart the system.

Notes

Chapter 7

BIOS

7-1 Introduction

This chapter describes the AMI BIOS Setup utility for the X9DA7/X9DAi. It also provides the instructions on how to navigate the AMI BIOS Setup utility screens. The AMI ROM BIOS is stored in a Flash EEPROM and can be easily updated.

Starting BIOS Setup Utility

To enter the AMI BIOS Setup utility screens, press the key while the system is booting up.

Note: In most cases, the key is used to invoke the AMI BIOS setup screen. There are a few cases when other keys are used, such as <F3>, <F4>, etc.

Each main BIOS menu option is described in this manual. The Main BIOS setup menu screen has two main frames. The left frame displays all the options that can be configured. Grayed-out options cannot be configured. Options in blue can be configured by the user. The right frame displays the key legend. Above the key legend is an area reserved for a text message. When an option is selected in the left frame, it is highlighted in white. Often a text message will accompany it.

Note: The AMI BIOS has default text messages built in. The manufacturer retains the option to include, omit, or change any of these text messages.

The AMI BIOS Setup utility uses a key-based navigation system called "hot keys." Most of the AMI BIOS setup utility "hot keys" can be used at any time during setup navigation. These keys include <F3>, <F4>, <Enter>, <ESC>, arrow keys, etc.

Note 1: Options printed in **Bold** are default settings.

Note 2: <F3> is used to load optimal default settings. <F4> is used to save the settings and exit the setup utility.

How To Change the Configuration Data

The configuration data that determines the system parameters may be changed by entering the AMI BIOS Setup utility. This Setup utility can be accessed by pressing <F2> at the appropriate time during system boot.

 **Note:** For AMI UEFI BIOS Recovery, please refer to the UEFI BIOS Recovery User Guide posted @<http://www.supermicro.com/support/manuals/>.

Starting the Setup Utility

Normally, the only visible Power-On Self-Test (POST) routine is the memory test. As the memory is being tested, press the <F2> key to enter the main menu of the AMI BIOS Setup utility. From the main menu, you can access the other setup screens. An AMI BIOS identification string is displayed at the left bottom corner of the screen below the copyright message.

Warning! Do not upgrade the BIOS unless your system has a BIOS-related issue. Flashing the wrong BIOS can cause irreparable damage to the system. In no event shall the manufacturer be liable for direct, indirect, special, incidental, or consequential damage arising from a BIOS update. If you have to update the BIOS, do not shut down or reset the system while the BIOS is being updated to avoid possible boot failure.



7-2 Main Setup

When you first enter the AMI BIOS Setup utility, you will enter the Main setup screen. You can always return to the Main setup screen by selecting the Main tab on the top of the screen. The Main BIOS Setup screen is shown below.



The AMI BIOS main menu displays the following information:

System Date

This item displays the system date in Day MM/DD/YY format (e.g. Wed 10/12/2011).

System Time

This item displays the system time in HH:MM:SS format (e.g. 15:32:52).

Supermicro X9DA7

SMC Version

This item displays the SMC version of the BIOS ROM used in this system.

SMC Build Date

This item displays the date that the BIOS Setup utility was built.

Memory Information

Total Memory

This displays the amount of memory that is available in the system.

7-3 Advanced Setup Configurations

Use the arrow keys to select Advanced Setup and press <Enter> to access the following submenu items.

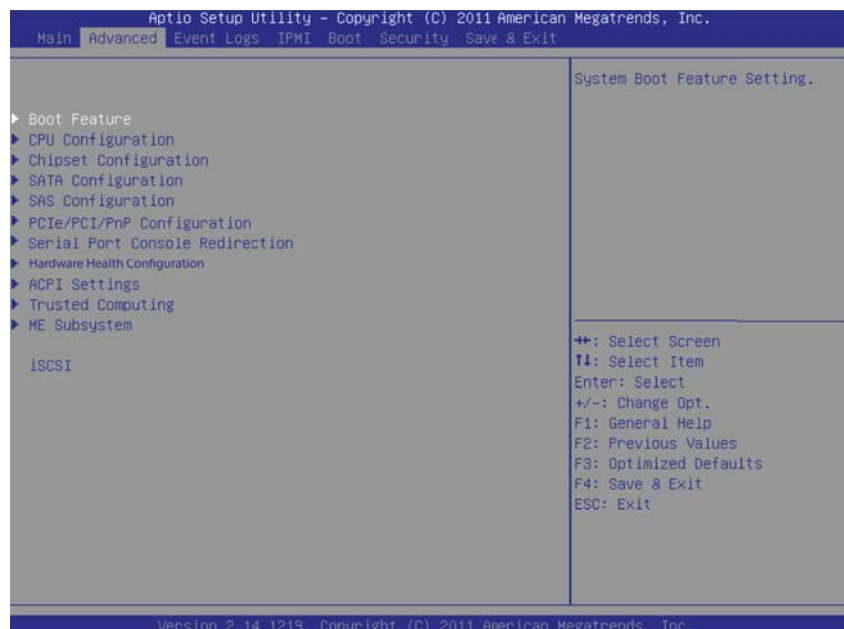

► Boot Features

Quiet Boot

This feature allows the user to select bootup screen display between POST messages and the OEM logo. Select Disabled to display the POST messages. Select Enabled to display the OEM logo instead of the normal POST messages. The options are Enabled and **Disabled**.

AddOn ROM Display Mode

Use this item to set the display mode for the Option ROM. Select Keep Current to use the current AddOn ROM Display setting. Select Force BIOS to use the Option ROM display mode set by the system BIOS. The options are **Force BIOS** and Keep Current.

Bootup Num-Lock

Use this feature to set the Power-on state for the Numlock key. The options are Off and **On**.

Wait For 'F1' If Error

Select Enabled to force the system to wait until the 'F1' key is pressed if an error occurs. The options are Disabled and **Enabled**.

Interrupt 19 Capture

Interrupt 19 is the software interrupt that handles the boot disk function. When this item is set to Enabled, the ROM BIOS of the host adaptors will "capture" Interrupt 19 at bootup and allow the drives that are attached to these host adaptors to function as bootable disks. If this item is set to Disabled, the ROM BIOS of the host adaptors will not capture Interrupt 19, and the drives attached to these adaptors will not function as bootable devices. The options are **Enabled** and Disabled.

Power Configuration

Watch Dog Function

If enabled, the Watch Dog timer will allow the system to reboot when it is inactive for more than 5 minutes. The options are Enabled and **Disabled**.

Power Button Function

If this feature is set to Instant_Off, the system will power off immediately as soon as the user presses the power button. If this feature is set to 4_Second_Override, the system will power off when the user presses the power button for 4 seconds or longer. The options are **Instant_Off** and 4_Second_Override.

Restore on AC Power Loss

Use this feature to set the power state after a power outage. Select Power-Off for the system power to remain off after a power loss. Select Power-On for the system power to be turned on after a power loss. Select Last State to allow the system to resume its last state before a power loss. The options are Power-On, Stay-Off and **Last State**.

EuP

Select Enabled to support the Low-power Compliance Mode for Energy-using Products (EuP). The options are Enable and **Disable**.

CPU Configuration

This submenu displays the information of the CPU as detected by the BIOS. It also allows the user to configuration CPU settings.

► Socket 0 CPU Information/Socket 1 CPU Information

This submenu displays the following information regarding the CPU installed in Socket 0 and (or) Socket 1 as detected by the BIOS.

- Type of CPU
- CPU Signature
- Microcode Patch
- CPU Stepping
- Maximum CPU Speed
- Minimum CPU Speed
- Processor Cores
- Intel HT (Hyper-Threading) Technology
- Intel VT-x Technology
- Intel SMX Technology
- L1 Data Cache
- L1 Code Cache
- L2 Cache
- L3 Cache

CPU Speed

This item displays the speed of the CPU installed in Socket 0.

64-bit

This item indicates if the CPU installed in Socket 0 supports 64-bit technology.

Clock Spread Spectrum

Select Enable to enable Clock Spectrum support, which will allow the BIOS to monitor and attempt to reduce the level of Electromagnetic Interference caused by the components whenever needed. The options are **Disabled** and Enabled.

Hyper-threading

Select Enabled to support Intel Hyper-threading Technology to enhance CPU performance. The options are **Enabled** and Disabled.

Active Processor Cores

Set to Enabled to use a processor's second core and above. (Please refer to Intel's website for more information.) The options are **All**, 1, 2, 3, 4, 5, 6, and 7.

Limit CPUID Maximum

This feature allows the user to set the maximum CPU ID value. Enable this function to boot the legacy operating systems that cannot support processors with extended CPUID functions. The options are Enabled and **Disabled** (for the Windows OS).

Execute-Disable Bit Capability (Available if supported by the OS & the CPU)

Select Enabled to enable the Execute Disable Bit which will allow the processor to designate areas in the system memory where an application code can execute and where it cannot, thus preventing a worm or a virus from flooding illegal codes to overwhelm the processor or damage the system during an attack. The default is **Enabled**. (Refer to Intel and Microsoft Web sites for more information.)

Intel® AES-NI

Select Enable to use the Intel Advanced Encryption Standard (AES) New Instructions (NI) to ensure data security. The options are **Enabled** and Disabled.

Hardware Prefetcher (Available when supported by the CPU)

If set to Enabled, the hardware prefetcher will prefetch streams of data and instructions from the main memory to the L2 cache to improve CPU performance. The options are Disabled and **Enabled**.

Adjacent Cache Line Prefetch (Available when supported by the CPU)

The CPU prefetches the cache line for 64 bytes if this feature is set to Disabled. The CPU prefetches both cache lines for 128 bytes as comprised if this feature is set to **Enabled**.

L1 Data Prefetch (Available when supported by the CPU)

Select Enabled to enable Level 1 data prefetch support to enhance system performance. For DP/MP servers, enable or disable this feature for system enhancement based on the specifications of the application running in the system at the time. The options are Disabled and **Enabled**.

Intel® Virtualization Technology (Available when supported by the CPU)

Select Enabled to support Intel Virtualization Technology, which will allow one platform to run multiple operating systems and applications in independent partitions, creating multiple "virtual" systems in one physical computer. The options are **Enabled** and Disabled.

Note: If there is any change to this setting, you will need to power off and restart the system for the change to take effect. Please refer to Intel's website for detailed information.)

► CPU Power Management Configuration

This submenu allows the user to configure the following CPU Power Management settings.

Power Technology

Select Energy Efficiency to support power-saving mode. Select Custom to customize system power settings. Select Disabled to disable power-saving settings. The options are Disabled, **Energy Efficiency**, and Custom.

Factory Long Duration Power Limit

This item displays the power limit set by the manufacturer during which long duration power is maintained.

Long Duration Power Limit

This item displays the power limit set by the manufacturer during which long duration power is maintained.

Factory Long Duration Maintained

This item displays the period of time set by the manufacturer during which long duration power is maintained.

Long Duration Maintained

This item displays the period of time during which long duration power is maintained.

Recommended Short Duration Power

This item displays the short duration power settings recommended by the manufacturer.

Short Duration Power Limit

This item displays the time period during which short duration power is maintained.

► Chipset Configuration

► North Bridge

This feature allows the user to configure the settings for the Intel North Bridge.

► Integrated IO Configuration

Intel VT-d

Select Enabled to enable Intel Virtualization Technology support for Direct I/O VT-d by reporting the I/O device assignments to the VMM (Virtual Working Memory) through the DMAR ACPI Tables. This feature offers fully-protected I/O resource sharing across Intel platforms, providing greater reliability, security and availability in networking and data-sharing. The options are **Enabled** and Disabled.

Intel I/OAT

The Intel I/OAT (I/O Acceleration Technology) significantly reduces CPU overhead by leveraging CPU architectural improvements, freeing the system resource for other tasks. The options are Disabled and **Enabled**.

DCA Support

Select Enabled to use Intel's DCA (Direct Cache Access) Technology to improve data transfer efficiency. The options are **Enabled** and Disabled.

IIO 0 PCIe Port Bifurcation Control/IIO 1 PCIe Port Bifurcation Control

This submenu allows the user to configure the following IO PCIe Port Bifurcation Control settings for IIO 0 PCIe port and IIO 1 PCIe port, which determine how to distribute the available PCI-Express lanes to the PCI-Exp. Root Ports.

IOU1-PCIe Port

This feature allows the user to set the PCI-Exp bus speed between IOU1 and PCIe port. The options are **x4x4** and x8.

Port 1A Link Speed

Select GEN1 to enable PCI-Exp Generation 1 support for Port 1A. Select GEN2 to enable PCI-Exp Generation 2 support for Port 1A. Select GEN3 to enable PCI-Exp Generation 3 support for Port 1A. The options are GEN1, **GEN2**, and GEN3.

Port 1B Link Speed

Select GEN1 to enable PCI-Exp Generation 1 support for Port 1B. Select GEN2 to enable PCI-Exp Generation 2 support for Port 1B. Select GEN3 to enable PCI-Exp Generation 3 support for Port 1B. The options are GEN1, and **GEN2**.

IOU2-PCIe Port

If this feature allows the user to set the bus speed between the IOU2 and the PCI-Exp port. The options are x4x4x4x4, x4x4x8, x8x4x4, x8x8, and **x16**.

Port 2A Link Speed

Select GEN1 to enable PCI-Exp Generation 1 support for Port 2A. Select GEN2 to enable PCI-Exp Generation 2 support for Port 2A. Select GEN3 to enable PCI-Exp Generation 3 support for Port 2A. The options are GEN1, **GEN2**, and GEN3.

IOU3-PCIe Port

If this feature allows the user to set the bus speed between the IOU2 and the PCI-Exp port. The options are x4x4x4x4, x4x4x8, x8x4x4, x8x8, and **x16**.

Port 3A Link Speed

Select GEN1 to enable PCI-Exp Generation 1 support for Port 3A. Select GEN2 to enable PCI-Exp Generation 2 support for Port 3A. Select GEN3 to enable PCI-Exp Generation 3 support for Port 3A. The options are GEN1, **GEN2**, and GEN3.

► QPI Configuration**Current QPI Link Speed**

This item displays the speed of the QPI Link.

Current QPI Frequency

This item displays the frequency of the QPI Link.

QPI (Quick Path Interconnect) Link Speed Mode

Use this feature to select data transfer speed for QPI Link connections. The options are **Fast** and Slow.

QPI Link Frequency Select

Use this feature to select the desired QPI frequency. The options are **Auto**, 6.4 GT/s, 7.2 GT/s, and 8.0 GT/s.

► DIMM Configuration

Current Memory Mode

This item displays the current memory mode.

Current Memory Speed

This item displays the current memory speed.

Mirroring

This item displays if memory mirroring is supported by the motherboard.

Sparing

This item displays if memory sparing can be supported by the motherboard.

► DIMM Information

P1/P2-DIMMA1/A2, P1/P2-DIMMB1/B2, P1/P2-DIMMC1/C2, P1/P2-DIMMD1/D2

The status of the memory modules specified will be displayed as detected by the BIOS.

CPU Socket 0 DIMM Information/CPU Socket 1 DIMM Information

Memory Mode

When Independent is selected, all DIMMs are available to the operating system. When Mirroring is selected, the motherboard maintains two identical copies of all data in memory for data backup. When Lockstep is selected, the motherboard uses two areas of memory to run the same set of operations in parallel. The options are **Independent**, Mirroring, Lockstep and Sparing.

DDR Speed

Use this feature to force a DDR3 memory module to run at a frequency other than what the system is specified in the specification. The options are **Auto**, Force DDR3-800, Force DDR3-1066, Force DDR3-1333, Force DDR3-1600 and Force SPD.

Channel Interleaving

This feature selects from the different channel interleaving methods. The options are **Auto**, 1 Way, 2 Way, 3 Way, and 4 Way.

Rank Interleaving

This feature allows the user to select a rank memory interleaving method. The options are **Auto**, 1 Way, 2 Way, 4, Way, and 8 Way.

Patrol Scrub

Patrol Scrubbing is a process that allows the CPU to correct correctable memory errors detected on a memory module and send the correction to the requestor (the original source). When this item is set to Enabled, the IO hub will read and write back one cache line every 16K cycles, if there is no delay caused by internal processing. By using this method, roughly 64 GB of memory behind the IO hub will be scrubbed every day. The options are **Enabled** and Disabled.

Demand Scrub

Demand Scrubbing is a process that allows the CPU to correct correctable memory errors found on a memory module. When the CPU or I/O issues a demand-read command, and the read data from memory turns out to be a correctable error, the error is corrected and sent to the requestor (the original source). Memory is updated as well. Select Enabled to use Demand Scrubbing for ECC memory correction. The options are Enabled and **Disabled**.

Data Scrambling

Select Enabled to enable data scrubbing and ensure data security and integrity. The options are **Disabled** and Enabled.

DRAM RAPL (Running Average Power Limit)

This item allows the user to select the average power limit setting when a DRAM module is in operation. The options are Disabled, Mode 0, and **Mode 1**.

Device Tagging

Select Enabled to support device tagging. The options are **Disabled** and Enabled.

Thermal Throttling

Throttling improves reliability and reduces power consumption in the processor via automatic voltage control during processor idle states. The options are Disabled and **CLTT** (Closed Loop Thermal Throttling).

OLTT (Open Loop Thermal Throttling) Peak BW (Bandwidth) %

This item sets a percentage of the peak bandwidth allowed for Open Loop Thermal Throttling. The range is between 25% and 100%. The default setting is **50** (%).

► South Bridge Configuration

This feature allows the user to configure the settings for the Intel PCH chip.

PCH Information

This feature displays the following PCH information.

Name: This item displays the name of the PCH chip.

Stepping: This item displays the status of the PCH stepping.

USB Devices: This item displays the USB devices detected by the BIOS.

All USB Devices

This feature enables all USB ports/devices. The options are Disabled and **Enabled**. (If set to Enabled, EHCI Controller 1 and Controller 2 will appear.)

EHCI Controller 1/EHCI Controller 2 (Available when All USB Devices is set to Enabled)

Select Enabled to enable Enhanced Host Controller Interface (EHCI) Controller 1/ Controller 2. The options are Disabled and **Enabled**.

Legacy USB Support (Available when USB Functions is not Disabled)

Select Enabled to support legacy USB devices. Select Auto to disable legacy support if USB devices are not present. Select Disable to have USB devices available for EFI (Extensive Firmware Interface) applications only. The settings are Disabled, **Enabled** and Auto.

Port 60/64 Emulation

Select Enabled to enable I/O port 60h/64h emulation support for the legacy USB keyboard so that it can be fully supported by the operating systems that does not recognize a USB device. The options are Disabled and **Enabled**.

EHCI Hand-Off

This item is for operating systems that do not support Enhanced Host Controller Interface (EHCI) hand-off. When enabled, EHCI ownership change will be claimed by the EHCI driver. The options are **Disabled** and Enabled.

Auto Configuration

Azalia HD (High Definition) Audio

Select Enabled to enable support for Azalia High Definition Audio. The options are **Enabled** and Disabled.

Azalia Internal HDMI Decode

Select Enabled to enable support for Azalia High Definition Multi-Media Interface Decode. The options are Enabled and **Disabled**.

►SATA Configuration

When this submenu is selected, the AMI BIOS automatically detects the presence of IDE or SATA devices and displays the following items.

SATA Port0~SATA Port5: The AMI BIOS displays the status of each SATA port as detected by the BIOS.

SATA Mode

Use this feature to configure SATA mode for a selected SATA port. The options are Disabled, IDE Mode, **AHCI Mode** and RAID Mode. The following are displayed depending on your selection:

IDE Mode

The following items are displayed when IDE Mode is selected:

Serial-ATA (SATA) Controller 0~1

Use this feature to activate or deactivate the SATA controller, and set the compatibility mode. The options for Controller 0 are Enhanced and **Compatible**. The default of SATA Controller 1 is **Enhanced**.

AHCI Mode

The following items are displayed when the AHCI Mode is selected.

Aggressive Link Power Management

Select Enabled to enable Aggressive Link Power Management support for Cougar Point B0 stepping and beyond. The options are **Enabled** and Disabled.

Port 0~5 Hot Plug

Select Enabled to enable hot-plug support for a particular port, which will allow the user to change a hardware component or device without shutting down the system. The options are Enabled and **Disabled**.

Staggered Spin Up

Select Enabled to enable Staggered Spin-up support to prevent excessive power consumption caused by multiple HDDs spinning-up simultaneously. The options are Enabled and **Disabled**.

RAID Mode

The following items are displayed when RAID Mode is selected:

PCH RAID CodeBase

Select Intel or LSI to specify the code base to be used for RAID support. The options are **Intel** and LSI.

Port 0~5 Hot Plug

Select Enabled to enable hot-plug support for the particular port. The options are Enabled and **Disabled**.

► SAS Configuration

OnChip SAS Oprom

Select Enabled to support the onboard SAS Option ROM to boot up the system via a storage device. The options are Disabled and **Enabled**.

SAS Option ROM Codebase

Select Intel to use the Intel SAS controller to support onboard SAS Option ROM. Select LSI to use the LSI SAS controller to support onboard SAS Option ROM. The options are **Intel** and LSI.

Device0~Device7: The AMI BIOS will automatically detect the onboard SAS devices and display the status of each SAS device as detected.

► PCIe/PCI/PnP Configuration

PCI ROM Priority

Use this feature to select the Option ROM to boot the system when there are multiple Option ROMs available in the system. The options are EFI Compatible ROM and **Legacy ROM**.

PCI Latency Timer

Use this feature to set the latency Timer of each PCI device installed on a PCI bus. Select 64 to set the PCI latency to 64 PCI clock cycles. The options are 32, **64**, 96, 128, 160, 192, 224 and 248.

Above 4G Decoding (Available if the system supports 64-bit PCI decoding)

Select Enabled to decode a PCI device that supports 64-bit in the space above 4G Address. The options are Enabled and **Disabled**.

PERR# Generation

Select Enabled to allow a PCI device to generate a PERR number for a PCI Bus Signal Error Event. The options are **Enabled** and Disabled.

SERR# Generation

Select Enabled to allow a PCI device to generate an SERR number for a PCI Bus Signal Error Event. The options are **Enabled** and Disabled.

Maximum Payload

Select Auto to allow the system BIOS to automatically set the maximum payload value for a PCI-E device to enhance system performance. The options are **Auto**, 128 Bytes, 256 Bytes, 512 Bytes, 1024 Bytes, 2048 Bytes, and 4096 Bytes.

Maximum Read Request

Select Auto to allow the system BIOS to automatically set the maximum Read Request size for a PCI-E device to enhance system performance. The options are **Auto**, 128 Bytes, 256 Bytes, 512 Bytes, 1024 Bytes, 2048 Bytes, and 4096 Bytes.

ASPM Support

This feature allows the user to set the Active State Power Management (ASPM) level for a PCI-E device. Select Force L0 to force all PCI-E links to operate at L0 state. Select Auto to allow the system BIOS to automatically set the ASPM level for the system. Select Disabled to disable ASPM support. The options are **Disabled**, Force L0, and Auto.



Warning: Enabling ASPM support may cause some PCI-E devices to fail!

Onboard LAN Option ROM Select

Select iSCSI to use the iSCSI Option ROM to boot the computer using a network device. Select PXE (Preboot Execution Environment) to use an PXE Option ROM to boot the computer using a network device. The options are iSCSI and **PXE**.

VGA Priority

This feature allows the user to select the graphics adapter to be used as the primary boot device. The options are **Onboard**, and Offboard.

Network Stack

Select Enabled enable PXE (Preboot Execution Environment) or UEFI (Unified Extensible Firmware Interface) for network stack support. The options are Enabled and **Disabled**.

► Serial Port Console Redirection

- **COM 1/COM 2**

These two submenus allow the user to configure the following Console Redirection settings for a COM Port specified by the user.

Console Redirection

Select Enabled to use a COM Port selected by the user for Console Redirection. The options are Enabled and Disabled. (The default setting for COM1 is Disabled, and for COM2 is Enabled.)

► Console Redirection Settings

This feature allows the user to specify how the host computer will exchange data with the client computer, which is the remote computer used by the user.

Terminal Type

This feature allows the user to select the target terminal emulation type for Console Redirection. Select VT100 to use the ASCII Character set. Select VT100+ to add color and function key support. Select ANSI to use the Extended ASCII Character Set. Select VT-UTF8 to use UTF8 encoding to map Unicode characters into one or more bytes. The options are **ANSI**, VT100, VT100+, and VT-UTF8.

Bits Per second

Use this feature to set the transmission speed for a serial port used in Console Redirection. Make sure that the same speed is used in the host computer and the client computer. A lower transmission speed may be required for long and busy lines. The options are 9600, 19200, 38400, 57600 and **115200** (bits per second).

Data Bits

Use this feature to set the data transmission size for Console Redirection. The options are 7 Bits and **8 Bits**.

Parity

A parity bit can be sent along with regular data bits to detect data transmission errors. Select Even if the parity bit is set to 0, and the number of 1's in data bits is even. Select Odd if the parity bit is set to 0, and the number of 1's in data bits is odd. Select None if you do not want to send a parity bit with your data bits in transmission. Select Mark to add a mark as a parity bit to be sent along with the data bits. Select Space to add a Space as a parity bit to be sent with your data bits. The options are **None**, Even, Odd, Mark and Space.

Stop Bits

A stop bit indicates the end of a serial data packet. Select 1 Stop Bit for standard serial data communication. Select 2 Stop Bits if slower devices are used. The options are **1** and **2**.

Flow Control

This feature allows the user to set the flow control for Console Redirection to prevent data loss caused by buffer overflow. Send a "Stop" signal to stop sending data when the receiving buffer is full. Send a "Start" signal to start sending data when the receiving buffer is empty. The options are **None**, Hardware RTS/CTS, and Software Xon/Xoff.

VT-UTF8 Combo Key Support

Select Enabled to enable VT-UTF8 Combination Key support for ANSI/VT100 terminals. The options are Enabled and **Disabled**.

Recorder Mode

Select Enabled to capture the data displayed on a terminal and send it as text messages to a remote server. The options are **Disabled** and Enabled.

Resolution 100x31

Select Enabled for extended-terminal resolution support. The options are Disabled and **Enabled**.

Legacy OS Redirection

Use this feature to select the number of rows and columns used in Console Redirection for legacy OS support. The options are **80x24** and 80x25.

Serial Port for Out-of-Band Management/Windows Emergency Management Services (EMS)

The submenu allows the user to configure the following Console Redirection settings to support Out-of-Band Serial Port management.

► Hardware Health Configuration

This feature allows the user to monitor system health and review the status of each item as displayed.

CPU Speed Control Mode

This feature allows the user to set the CPU speed mode. Select Optimal to reduce CPU speed for optimal power saving. Select Full Speed for the CPU to run at the full speed which will increase power consumption. The options are Standard, Full Speed and Optimal.

CPU 1 Temperature/CPU 2 Temperature

The CPU Temperature feature will display the CPU temperature status as detected by the BIOS:

Low - This level is considered as the 'normal' operating state. The CPU temperature is well below the CPU 'Temperature Tolerance'. The motherboard fans and CPU will run normally as configured in the BIOS (Fan Speed Control).

Medium - The processor is running warmer. This is a 'precautionary' level and generally means that there may be factors contributing to this condition, but the CPU is still within its normal operating state and below the CPU 'Temperature Tolerance'. The motherboard fans and CPU will run normally as configured in the BIOS. The fans may adjust to a faster speed depending on the Fan Speed Control settings.

High - The processor is running hot. This is a 'caution' level since the CPU's 'Temperature Tolerance' has been reached (or has been exceeded) and may activate an overheat alarm. The system may shut down if it continues for a long period to prevent damage to the CPU. If the system buzzer and Overheat LED has activated, take action immediately by checking the system fans, chassis ventilation and room temperature to correct any problems.

System Temperature

System temperature will be displayed as detected by the BIOS.

Fan Speed Rating

This feature displays the fan speed readings from Fan 1~Fan 6 and Fan A.

Voltage Readings

The following voltage readings will be displayed.

CPU1 Vcore, CPU2 Vcore, CPU1 VDIMM, CPU2 VDIMM, 1.1V, 1.5V, 5V, SVSB, 12V, -12V, 3.3V, 3.3VSB, and VBAT

►ACPI Setting

Use this feature to configure Advanced Configuration and Power Interface (ACPI) power management settings for your system.

ACPI Sleep State

Use this feature to select the ACPI State when the system is in sleep mode. Select S1 (CPU_Stop_Clock) to erase all CPU caches and stop executing instructions. Power to the CPU(s) and RAM is maintained, but RAM is refreshed. Select Suspend to use power-reduced mode. Power will only be supplied to limited components (such as RAMs) to maintain the most critical functions of the system. The options are S1 (CPU_Stop_Clock), Suspend **Disabled**, and S3 (Suspend to RAM).

High Precision Event Timer

Select Enabled to activate HPET, which produces periodic interrupts at a much higher frequency than a Real-time Clock (RTC) does in synchronizing multimedia streams, providing smooth playback, and reducing the dependency on other time-stamp calculation devices, such as an x86 RDTSC Instruction embedded in the CPU. The High Performance Event Timer is used to replace the 8254 Programmable Interval Timer. The options are **Enabled** and Disabled.

► Trusted Computing (Available when a TPM device is detected)

TPM Support

Select Enabled on this item and enable the TPM jumper on the motherboard to enable TPM support to improve data integrity and network security. The options are **Enabled** and Disabled.

TPM State

Select Enabled to enable TPM security settings to improve data integrity and network security. The options are Disabled and **Enabled**.

Pending Operation: This item displays the status of a pending operation.

Current Status Information: This item displays the information regarding the current TPM status.

TPM Enable Status

This item displays the status of TPM Support to indicate if TPM is currently enabled or disabled.

TPM Active Status

This item displays the status of TPM Support to indicate if TPM is currently active or deactivated.

TPM Owner Status

This item displays the status of TPM Ownership.

► ME Subsystem Configuration

This feature displays the following ME Subsystem Configuration settings.

Intel ME (Management Engine) Subsystem

Select Enabled to enable support for Intel Management Engine Subsystem that carry out various tasks in the background to enhance overall system performance. The options are **Enabled** and Disabled.

- **ME BIOS Interface Version**
- **ME Version**

iSCSI: This item displays the following iSCSI information:

iSCSI Initiation Name: This item displays the name of the iSCSI Initiator, which is a unique name used in the world.

7-4 Event Logs

Use this feature to configure Event Log settings.

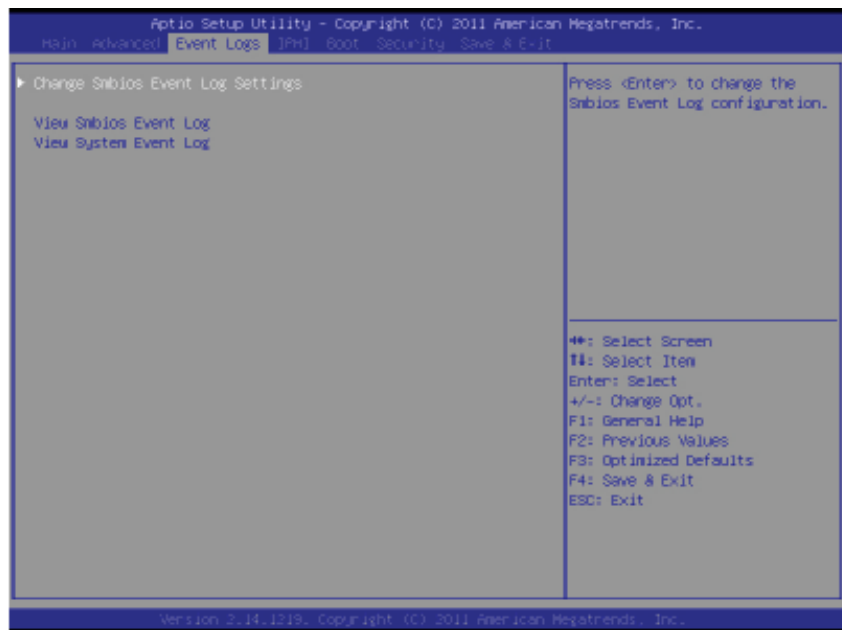

►Change SMBIOS Event Log Settings

This feature allows the user to configure SMBIOS Event settings.

Enabling/Disabling Options

SMBIOS Event Log

Select Enabled to enable SMBIOS (System Management BIOS) Event Logging during system boot. The options are **Enabled** and Disabled.

Runtime Error Logging Support

Select Enabled to support Runtime Error Logging. The options are **Enabled** and Disabled.

Memory Correctable Error Threshold

This feature allows the user to enter the threshold value for correctable memory errors. The default setting is **10**.

PCI Error Logging Support

Select Enabled to support error event logging for PCI slots. The options are Enabled and **Disabled**.

Erasing Settings

Erase Event Log

Select Enabled to erase the SMBIOS (System Management BIOS) Event Log, which is completed before a event logging is initialized upon system reboot. The options are **No**, Yes Next Reset, and Yes Every Reset.

When Log is Full

Select Erase Immediately to immediately erase SMBIOS error event logs that exceed the limit when the SMBIOS event log is full. Select Do Nothing for the system to do nothing when the SMBIOS event log is full. The options are **Do Nothing** and Erase Immediately.

SMBIOS Event Log Standard Settings

Log System Boot Event

Select Enabled to log system boot events. The options are **Disabled** and Enabled.

MECI (Multiple Event Count Increment)

Enter the increment value for the multiple event counter. Enter a number between 1 to 255. The default setting is **1**.

METW (Multiple Event Count Time Window)

This item allows the user to decide how long (in minutes) should the multiple event counter wait before generating a new event log. Enter a number between 0 to 99. The default setting is **60**.

View SMBIOS Event Log

This item allows the user to view the event in the SMBIOS event log. Select this item and press <Enter> to view the status of an event in the log.

- Date
- Time
- Error Code

- Severity

View System Event Log

This item allows the user to view the event in the system event log. Select this item and press <Enter> to view the status of an event in the log.

- Date
- Time
- Sensor
- Type

7-5 Boot

This submenu allows the user to configure the following boot settings for the system.

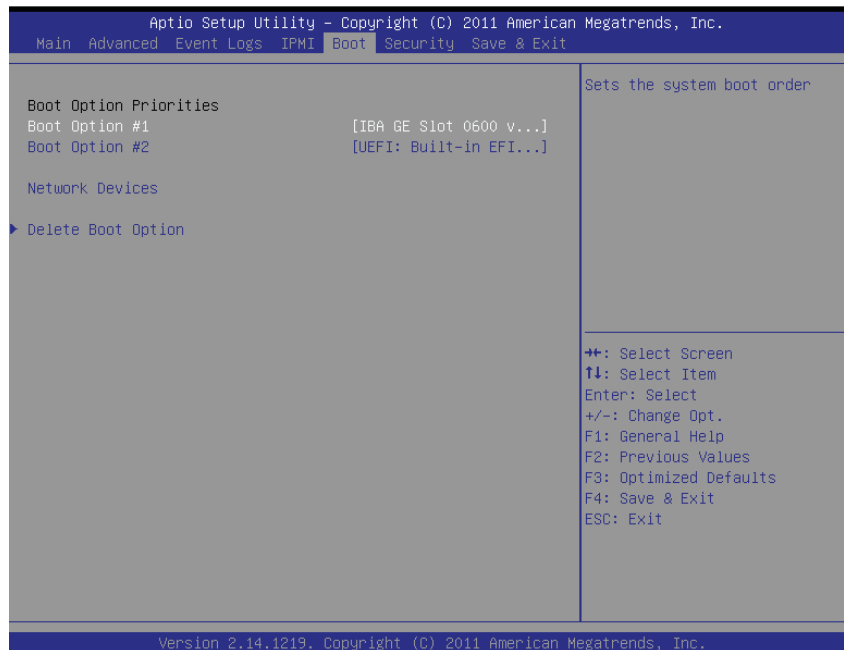

Boot Option Priorities

Boot Option #1

This item allows the user to select the first boot drive. Select a LAN device to boot the system from the network connection. Select UEFI to boot the system from the UEFI: Built-in EFI Shell. The options are **LAN Device**, UEFI: Built-in EFI Shell, and Disabled.

Boot Option #2

This item allows the user to select the first boot device. Select a LAN device to boot the system from the network connection. Select UEFI to boot the system from the UEFI: Built-in EFI Shell. The options are LAN Device, **UEFI: Built-in EFI Shell**, and Disabled.

Network Devices

►Delete Boot Options

Delete Boot Option

This item allows the user to select a boot device to delete from the boot priority list. Select UEFI: Built-in EFI Shell to delete it from the boot priority list which will prevent system boot from the UEFI Shell. The options are Select One to Delete and **UEFI: Built-in EFI Shell**.

7-6 Security

This menu allows the user to configure the following security settings for the system.

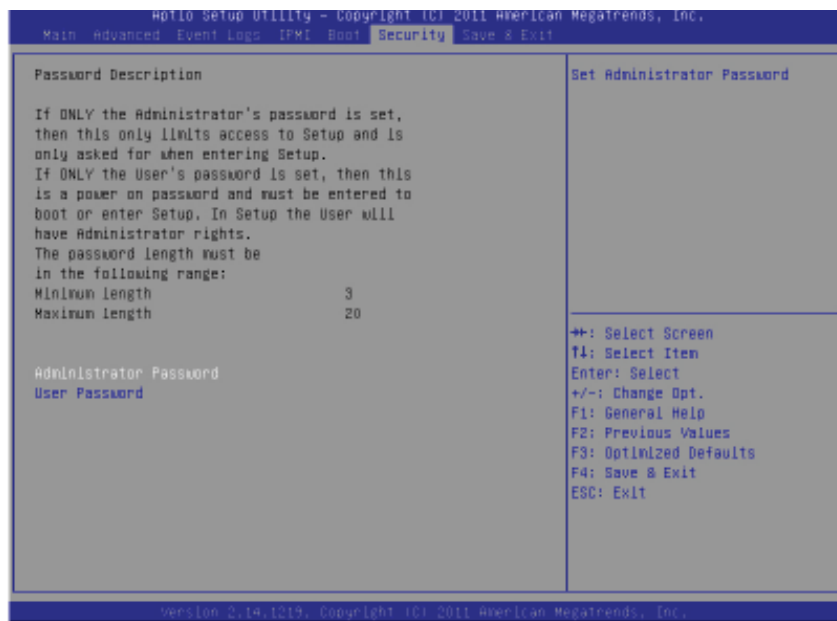

Administrator Password

Use this feature to set the Administrator Password which is required to enter the BIOS setup utility. The length of the password should be from 3-character to 8-character long.

User Password

Use this feature to set a User Password which is required to log into the system and to enter the BIOS setup utility. The length of the password should be from 3-character to 8-character long.

7-7 Save & Exit

This submenu allows the user to configure the Save and Exit settings for the system.

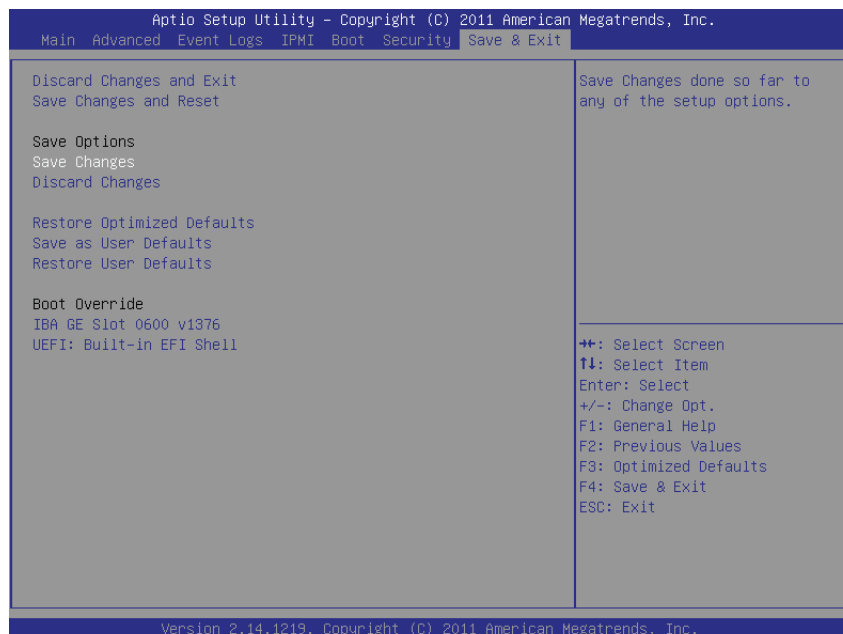

Discard Changes and Exit

Select this option to quit the BIOS Setup without making any permanent changes to the system configuration, and reboot the computer. Select Discard Changes and Exit, and press <Enter>. When the dialog box appears, asking you if you want to exit the BIOS setup without saving, click **Yes** to quit BIOS without saving the changes, or click No to quit the BIOS and save changes.

Save Changes and Reset

When you have completed the system configuration changes, select this option to save the changes and reboot the computer so that the new system configuration settings can take effect. Select Save Changes and Exit, and press <Enter>. When the dialog box appears, asking you if you want to exit the BIOS setup without sav-

ing, click **Yes** to quit BIOS without saving the changes, or click No to quit the BIOS and save changes.

Save Options

Save Changes

Select this option and press <Enter> to save all changes you've done so far and return to the AMI BIOS utility Program. When the dialog box appears, asking you if you want to save configuration, click **Yes** to save the changes, or click No to return to the BIOS without making changes.

Discard Changes

Select this feature and press <Enter> to discard all the changes and return to the BIOS setup. When the dialog box appears, asking you if you want to load previous values, click **Yes** to load the values previous saved, or click No to keep the changes you've made so far.

Restore Optimized Defaults

Select this feature and press <Enter> to load the optimized default settings that help optimize system performance. When the dialog box appears, asking you if you want to load optimized defaults, click **Yes** to load the optimized default settings, or click No to abandon optimized defaults.

Save as User Defaults

Select this feature and press <Enter> to save the current settings as the user's defaults. When the dialog box appears, asking you if you want to save values as user's defaults, click **Yes** to save the current values as user's default settings, or click No to keep the defaults previously saved as the user's defaults.

Restore User Defaults

Select this feature and press <Enter> to load the user's defaults previously saved in the system. When the dialog box appears, asking you if you want to restore user's defaults, click **Yes** to restore the user's defaults previously saved in the system, or click No to abandon the user's defaults that were previously saved.

Boot Override

This feature allows the user to enter a new setting to overwrite the original setting that was saved for the following devices:

- LAN Device
- UEFI: Built-in EFI Shell

Notes

Appendix A

BIOS Error Beep Codes

During the POST (Power-On Self-Test) routines, which are performed at each system boot, errors may occur.

Non-fatal errors are those which, in most cases, allow the system to continue to boot. The error messages normally appear on the screen.

Fatal errors will not allow the system to continue with bootup procedure. If a fatal error occurs, you should consult with your system manufacturer for possible repairs.

These fatal errors are usually communicated through a series of audible beeps. The numbers on the fatal error list correspond to the number of beeps for the corresponding error.

BIOS Error Beep Codes		
Beep Code/LED	Error Message	Description
1 beep	Refresh	Circuits have been reset. (Ready to power up)
5 short beeps + 1 long beep	Memory error	No memory detected in the system
5 long beeps + 2 short beeps	Display memory read/write error	Video adapter missing or with faulty memory
1 continuous beep	System overheat	System overheat

Notes

Appendix B

System Specifications

Processors

Two Intel E5-2600 processors in LGA 2011 sockets

Note: Please refer to our web site for a complete listing of supported processors.

Chipset

Intel C600

BIOS

8 Mb AMI SPI Flash EEPROM

Memory Capacity

Sixteen DIMM sockets supporting up to 512 GB of registered/unbuffered ECC DDR3-1600/1333/1066/800 LRDIMMs

Note: See the memory section in Chapter 5 for details.

SAS Controller (7047A-73 only)

LSI 2308 controller for eight-port SAS (RAID supported)

SATA Controller

Intel on-chip controller for six-port SATA 3.0/2.0 (RAID supported)

Drive Bays

Eight hot-swap drive bays to house eight SAS or six SATA drives

Peripheral Drive Bays

Two 5.25" drive bays

Expansion Slots

Supports the use of six standard size PCI add-on cards: three PCI-E 3.0 x16, two PCI-E 3.0 x8 and one PCI-E 3.0 x4 slots.

Serverboard

X9DA7 (7047A-73) or X9DAi (7047A-T) (Extended ATX form factor)

Dimensions: 12" x 13" (305 x 330 mm)

Chassis

SC743TQ-1200B-SQ Form Factor: tower/4U rackmount

Dimensions (as tower): (WxHxD) 7 x 17.2 x 25.5 in. (178 x 437 x 648 mm)

Weight

Gross (Bare Bone): 64 lbs. (29.1 kg.)

System Cooling

Two (2) 8-cm low-noise chassis fans

One (1) 9-cm low-noise exhaust fan

Two (2) active CPU heatsinks

System Input Requirements

AC Input Voltage: 100-240 VAC

Rated Input Current: 8A (115V) to 12A (240V)

Rated Input Frequency: 50-60 Hz

Power Supply

Rated Output Power: 1200W w/PFC (Part# PWS-1K25P-PQ)

Rated Output Voltages: +3.3V (20A), +5V (20A), +12V (99A), -12V (0.3A), +5Vsb (3A)

Power Supply Efficiency Rating: 94% (peak)

Operating Environment

Operating Temperature: 10° to 35° C (50° to 95° F)

Non-operating Temperature: -40° to 70° C (-40° to 158° F)

Operating Relative Humidity: 8% to 90% (non-condensing)

Non-operating Relative Humidity: 5 to 95% (non-condensing)

Regulatory Compliance

Electromagnetic Emissions: FCC Class B, EN 55022 Class B, EN 61000-3-2/-3-3, CISPR 22 Class B

Electromagnetic Immunity: EN 55024/CISPR 24, (EN 61000-4-2, EN 61000-4-3, EN 61000-4-4, EN 61000-4-5, EN 61000-4-6, EN 61000-4-8, EN 61000-4-11)

Safety: CSA/EN/IEC/UL 60950-1 Compliant, UL or CSA Listed (USA and Canada), CE Marking (Europe)

California Best Management Practices Regulations for Perchlorate Materials:

This Perchlorate warning applies only to products containing CR (Manganese Dioxide) Lithium coin cells. "Perchlorate Material-special handling may apply. See www.dtsc.ca.gov/hazardouswaste/perchlorate"

Notes

(continued from front)

The products sold by Supermicro are not intended for and will not be used in life support systems, medical equipment, nuclear facilities or systems, aircraft, aircraft devices, aircraft/emergency communication devices or other critical systems whose failure to perform be reasonably expected to result in significant injury or loss of life or catastrophic property damage. Accordingly, Supermicro disclaims any and all liability, and should buyer use or sell such products for use in such ultra-hazardous applications, it does so entirely at its own risk. Furthermore, buyer agrees to fully indemnify, defend and hold Supermicro harmless for and against any and all claims, demands, actions, litigation, and proceedings of any kind arising out of or related to such ultra-hazardous use or sale.