

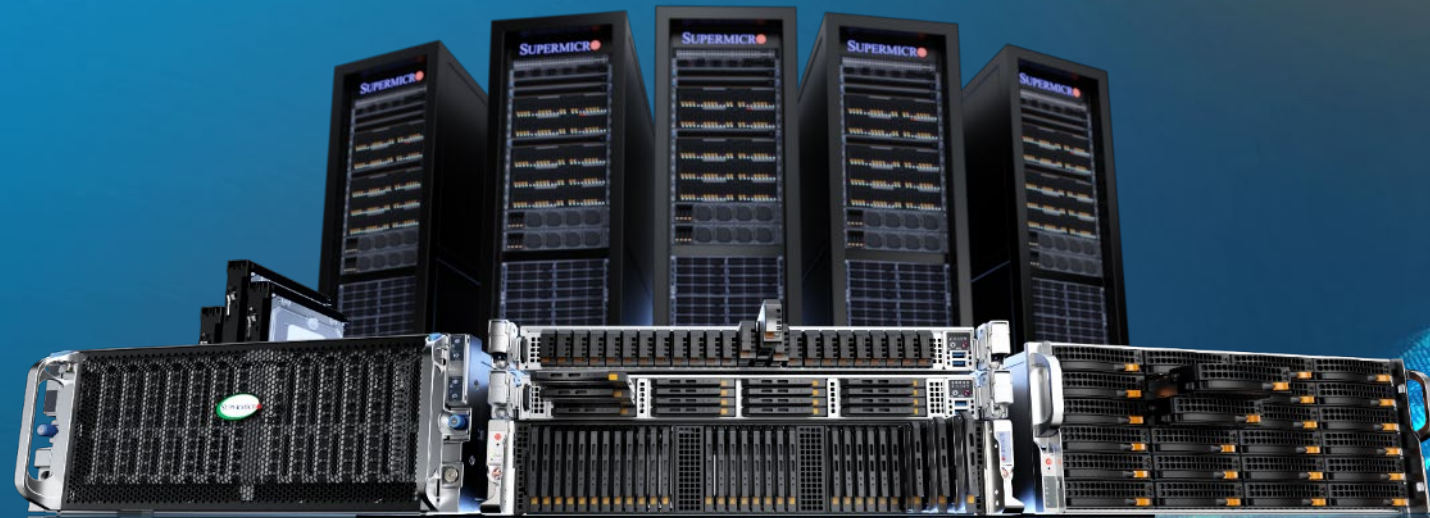

STORAGE SOLUTIONS

Scalable and Flexible All Flash, Hybrid, Disk and
Multi-Node Storage Architectures

YOUR NAME HERE



About Supermicro

Revenue

\$14B+

(FY2024 guidance)

150%+ YoY

\$7.1B (FY2023)

\$5.2B (FY2022)

Worldwide Presence

Silicon Valley based

Facilities in The Netherlands, Taiwan, Malaysia and others

6M+ Sq ft.

Facilities Worldwide

Production

\$18B/yr.

Production Capacity or ~1.3M units annually (CY23)

Top 5

Server System Provider Worldwide (IDC & Gartner 2022)

Human Resource

6,000+

Headcount across 4 campuses Worldwide

~50%

Focused on Technical / R&D

Leadership Stats

#1

in Generative AI and LLM Platforms

500%+

YoY Growth in Accel. Computing

The Supermicro Advantage

We build rack-scale IT solutions, optimized for our customer's business goals at every step in our highly integrated supply chain.

With 30 years of technology leadership, Supermicro meets the needs of the entire data center, with a portfolio of application-optimized systems, cluster-level design, and on-site service.

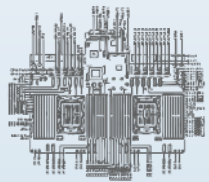

Architecture

Extensive R&D capabilities starting with individual components, scaled up to data center clusters.

Production

4,000 racks per month produced worldwide with accelerated time-to-market.

Solution Design

Engineering and integration team develops and thoroughly validates solution.

Deployment

Plug and play service for seamless deployment in any datacenter environment.



Application-Optimized Storage Systems

4 Reasons to Choose Supermicro:

1

Full Portfolio:

Designed to exceed the needs of HPC, AI, and Cloud, a variety of systems cover the full range of storage tiers from archiving to application storage.

2

Rack-Scale:

USA-made systems are delivered to customers in weeks. Engineering and integration team develops and deploys storage solutions into existing or new infrastructure.

3

System Architecture:

The mechanical layout is designed for airflow and high serviceability. Each system topology is engineered to maximize performance for its intended application.

4

Interoperability:

Systems utilize the latest standards in protocols and form factors such as NVMe EDSFF and are validated on industry-leading software-defined storage platforms.



The Supermicro Customer Advantage

Enable your edge with our industry leading capabilities

Key Supermicro Advantages

Key Customer Benefits

**Product Customization
and Integration**



Rack-Scale Integration
Software Integration
OEM & CSP Customization

Advanced System Technology

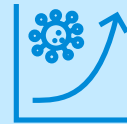

Leading Time-to-Market
Proven Chassis Designs
Innovative Liquid Cooling

Vertical Integration



Supply Chain Control
In-House Manufacturing (USA+)
In-House Key Supplier (PSU+)
Cost Management

Supermicro's Building Block Design Approach

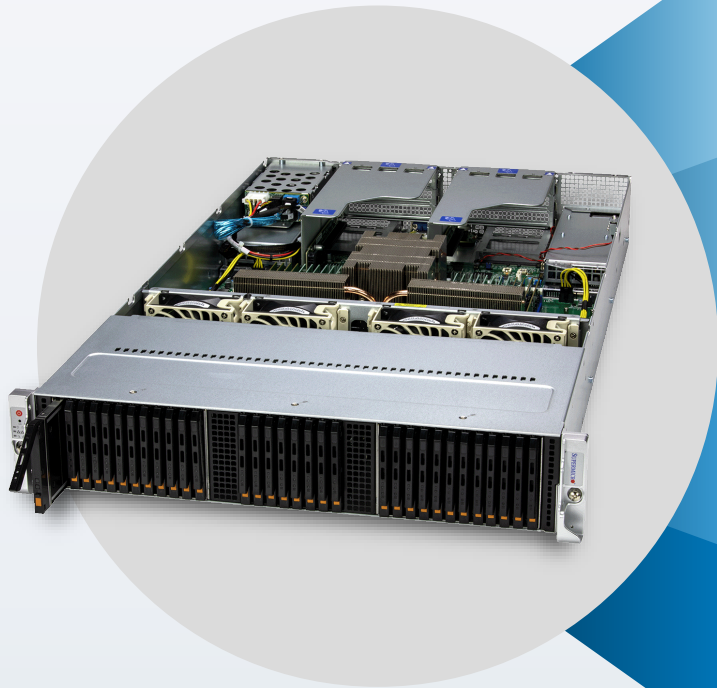

Chassis

Mother Boards

Storage Controllers
and Media

Rack Integration
and Liquid Cooling

-
- North America, EU and Taiwan Manufacturing
 - Global Service and Support
 - Rack Scale Delivery
 - ISV Validations
-

Why Supermicro Software-defined Storage?

More **economical**, more **flexible** and **higher performance** than proprietary storage appliances.

1

Works with all of the most popular Software-defined Storage ISVs.

2

Allows rack level integration, testing with compute and networking and a single support contract.

3

Broadest portfolio of storage building blocks.

4

Works with all key component suppliers (CPUs, DRAM, SSD, HDDs, networking) ensuring managed supply chain and best pricing.

The Industry's Broadest Portfolio of Storage Systems

ENTERPRISE



- **Optimized for enterprise data centers and edge deployments**
- Front access, double-sided, and Simply Double product families
- 2U/3U/4U form factors
- 16-36 3.5" LFF Bays
- Single or dual Intel and AMD CPUs

TOP-LOADING



- **Maximum capacity for cloud-scale storage in 4U FF**
- **Highest storage capacity and \$/TB value**
- Single node and dual-server systems
- 60, 90 drives in 4U
- Dual Intel CPUs

SIMPLY DOUBLE



- **High density LFF storage in 2U FF**
- Four node 2-way servers in a 2U chassis
- Up to 12x2.5" bays or 6x3.5" NVMe/SAS/SATA bays per node
- Dual Intel or AMD CPUs

HA DUAL-PORT



- **High Availability Dual Port (Active-Active or Active-Passive)**
- **Shared Everything Architecture (Storage Bridge Bay)**
- All-flash U.2 NVMe
- Up to 24 U.2 NVMe SSDs
- 2U Form Factor
- Single Intel CPU, dual server configuration

PETASCALE ALL-FLASH



- **Revolutionary storage performance and capacity**
- **Highest IOPS and BW performance**
- All-flash EDSFF NVMe
- Up to 32 E3.S NVMe SSDs
- 1U and 2U Form Factors
- Single or dual Intel and AMD CPUs

MULTI-NODE SYSTEMS



- **Cluster-in-a-box for entry object and parallel file systems**
- Compact multi-node scale-out clusters in a single chassis
- Four node 2-way servers in a 2U chassis
- Up to 12x2.5" bays or 6x3.5" NVMe/SAS/SATA bays per node
- Dual Intel or AMD CPUs

Supermicro Storage Server Portfolio Overview

From High-Capacity 90-Drive Systems to High-Performance All-Flash NVMe Systems

Capacity

Enterprise



Featuring up to 36 LFF drives, front/rear drive access for enterprise storage building block.

Top Loading



Featuring up to 90 LFF drives and single or twin controller for cloud scale object and file storage.

Simply Double



Featuring up to 24 LFF and 4 NVMe drives for hybrid performance storage.

High Availability SBB



Featuring up to 24 dual port NVMe and dual canister design for high availability storage.

Petascale All-Flash



Featuring up to 32 E3.S NVMe drives provides ultra high performance and density all-flash storage.

Performance

Supermicro Storage Server Portfolio Overview

From High-Capacity 90-Drive Systems to High-Performance All-Flash NVMe Systems

Enterprise



Featuring up to 36 LFF drives, front/rear drive access for enterprise storage building block.

Top Loading
Object Storage
Backup & Archive
Enterprise Applications
NAS/SAN
AI/ML Capacity Tier
Block Storage
Analytics & Big Data
Surveillance

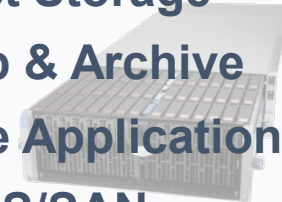

Featuring up to 90 LFF drives and single or twin controller for cloud scale object storage.

Simply Double



Featuring up to 24 LFF and 4 NVMe drives for hybrid performance storage.

High Availability

Parallel File Systems
Scale-out File Systems
Virtualization/HCI/vSAN



Database
AI/ML Performance
HPC
VDI
Featuring up to 24 LFF, support NVMe and dual canister design for high availability storage.

Petascale All-Flash



Featuring up to 32 E3.S NVMe drives provides ultra high performance and density all-flash storage.



1U Petascale All-Flash Storage

PCIe 5.0 Slots
Up to 2 x16 slots +
2 AIOMs

DDR5 Slots
Up to 32 DIMMs

**Single or Dual
Processor**
Up to 300W TDP

E3.S EDSFF
Next-gen form factor

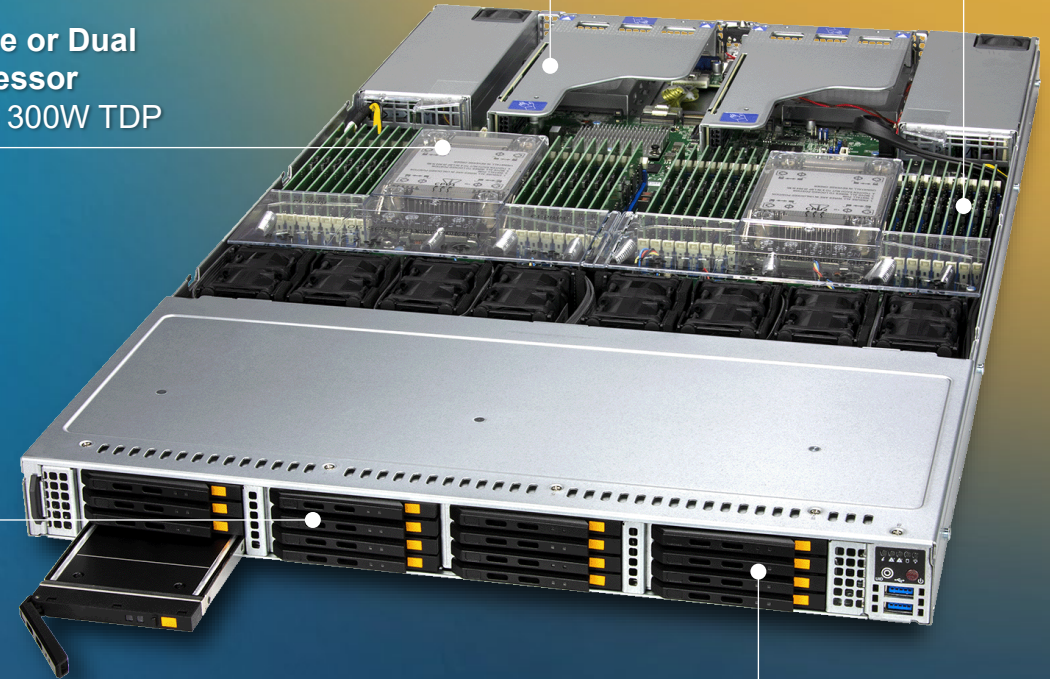

**Optional E3.S 2T x8
CXL Support**

Redundant Power Supply
1600W (Titanium level)



PCIe 5.0 Slots
x16 AIOMs

PCIe 5.0 Slots
x16 slots



2U Petascale All-Flash Storage

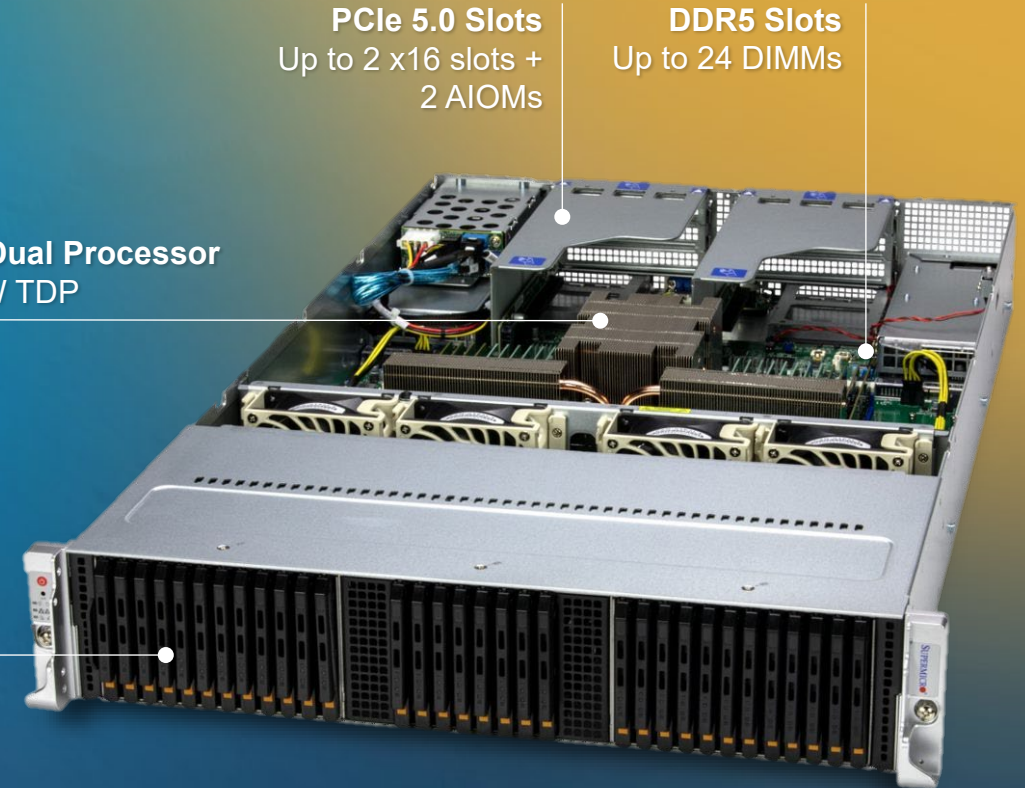

PCIe 5.0 Slots
Up to 2 x16 slots +
2 AIOMs

DDR5 Slots
Up to 24 DIMMs

Single or Dual Processor
Up to 350W TDP

E3.S EDSFF
Up to 32 E3 1T slots



Redundant Power Supply
2000W (Titanium level)

Hot swap U.2

PCIe 5.0 Slots
x16 AIOMs

PCIe 5.0 Slots
x8 or x16 slots

Petascale EDSFF* All-Flash Highlights



Key Features

- Support dual Intel socket and single AMD socket CPUs
- Support 1U E1.S and E3.S and 2U E3.3 TLC, QLC and CXL device and up to 1PB all flash in 2U
- Optimized thermal design with EDSFF Spec
- Balanced PCIe lanes for front SSD and rear IO design
- Up to 30M 4KB RR IOPS and 230+ GB/s 128KB SR BW.

Target Solutions

- High-performance parallel file systems
- High performance AI SDS building blocks
- Virtualization & dense VDI
- High performance object storage
- Hyperconverged infrastructure
- High performance CDN and video streaming

*Enterprise and Data Center Standard Form Factor

1U Petascale All-Flash Storage Specifications



1U E1.S 24-Bay



1U E3.S 16-Bay



1U E3.S 16-Bay

Model Number	SSG-121E-NES24R	SSG-121E-NE316R/SSG-121E-NEX316R	ASG-1115S-NE316R/ASG-1115S-NEX316R
CPU	Dual 4 th Gen Intel® Xeon® Scalable Processors up to 270W TDP	Dual 4 th Gen Intel® Xeon® Scalable Processors up to 270W TDP	Single AMD EPYC™ 9004 Series Processor up to 300W TDP
Memory	32 DIMM slots; Up to 8TB DDR5-4800	32 DIMM slots; Up to 8TB DDR5-4800	24 DIMM slots; Up to 6TB DDR5-4800
Expansion	2 PCIe 5.0 x16 FHHL slots 2 PCIe 5.0 x16 AIOM slots	2 PCIe 5.0 x16 FHHL slots 2 PCIe 5.0 x16 AIOM slots	2 PCIe 5.0 x16 FHHL slots 2 PCIe 5.0 x16 AIOM slots
Storage	24 hot-swap 9.5mm/15mm E1.S	16 hot-swap 7.5mm E3.S Up to 4 E3.S CXL x8 slots (optional)	16 hot-swap 7.5mm/16.8mm E3.S Up to 4 E3.S CXL x8 slots (optional)
Networking	via AIOM	via AIOM	via AIOM
Power Supplies	Redundant 2000W Titanium level	Redundant 1600W Titanium level	Redundant 1600W Titanium level
Workloads	Software-defined Storage, Data Intensive HPC, NVMe Over Fabrics Solution, In-Memory Computing, Private & Hybrid Cloud		

1U Petascale All-Flash Storage Specifications



2U E3.S 24-Bay

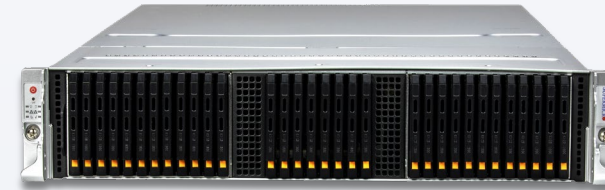

2U E3.S 32-Bay

Model Number	SSG-221E-NE324R	ASG-2115S-NE332R
CPU	Dual 4 th Gen Intel® Xeon® Scalable Processors up to 270W TDP	Single AMD EPYC™ 9004 Series Processors up to 350W TDP
Memory	32 DIMM slots; Up to 8TB DDR5-4800	24 DIMM slots; Up to 6TB DDR5-4800
Expansion	2 PCIe 5.0 x8 FHHL slot 2 PCIe 5.0 x16 FHHL slot (x8 if above slots occupied) 2 PCIe 5.0 x16 AIOM slot	2 PCIe 5.0 x8 FHHL slot 2 PCIe 5.0 x16 FHHL slot (x8 if above slots occupied) 2 PCIe 5.0 x16 AIOM slots
Storage	24 hot-swap 7.5mm E3.S	32 hot-swap 7.5mm E3.S
Networking	via AIOM	via AIOM
Power Supplies	Redundant 2000W Titanium level	Redundant 2000W Titanium level
Workloads	Software-defined Storage, In-Memory Computing, Data Intensive HPC, Private & Hybrid Cloud, NVMe Over Fabrics Solution	



NEW!

2U High Availability Dual Port All-Flash Storage

PCIe 5.0 Slots
Up to 2 x16 slots +
2 x 8 slots

DDR5 Slots
Up to 8 DIMMs

Single Processor
Up to 350W TDP

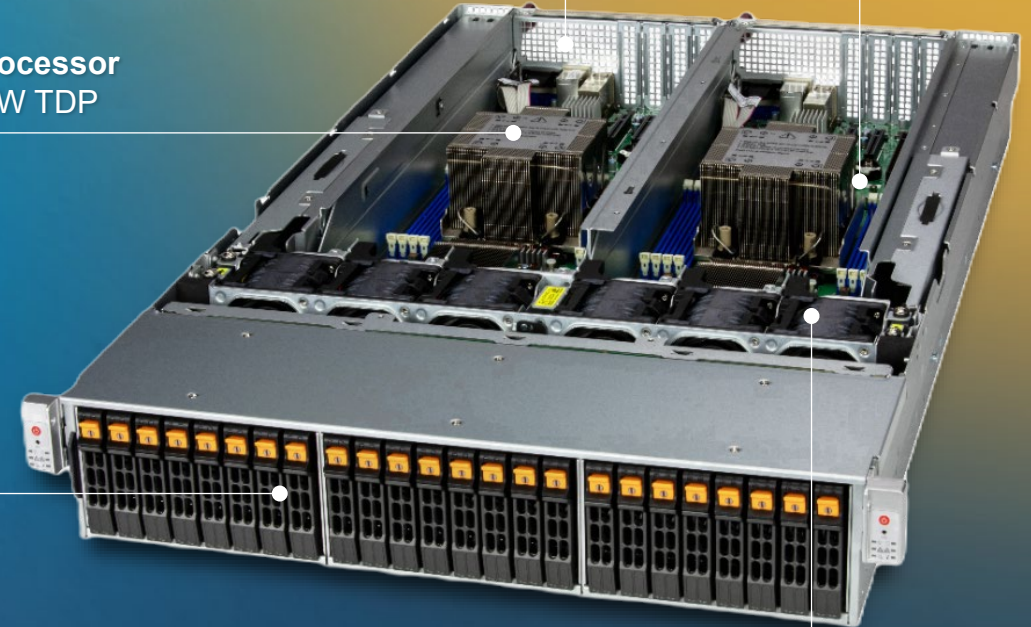

U.2 dual port NVMe
Up to 24 slots

Dual Canisters
Gen5 x16 NTB and 1GbE for
node-to-node communication

PCIe 5.0 Slots
Up to 2 x16 slots +
2 x 8 slots



Redundant Power Supply
2000W (Titanium level)

2x 10GbE RJ45

2U High Availability Dual-Port Storage Specifications



2U U.2 24-Bay

Model Number	SSG-221E-DN2R24R
CPU (per node)	Single 5 th Gen Intel® Xeon® Scalable Processors up to 350W TDP
Memory (per node)	8 DIMM slots; Up to 2TB DDR5-5600
Expansion (per node)	2 PCIe 5.0 x8 FHHL slots 2 PCIe 5.0 x16 FHHL slots
Storage	24 hot-swap 15mm dual port U.2
Networking (per node)	Dual 10GbE BaseT with Intel® X710
Power Supplies	Redundant 2000W Titanium level
Workloads	Software-defined Storage, Mission Critical Database, Parallel File System Metadata node

2U24 Dual-Port U.2 HA Storage Highlight

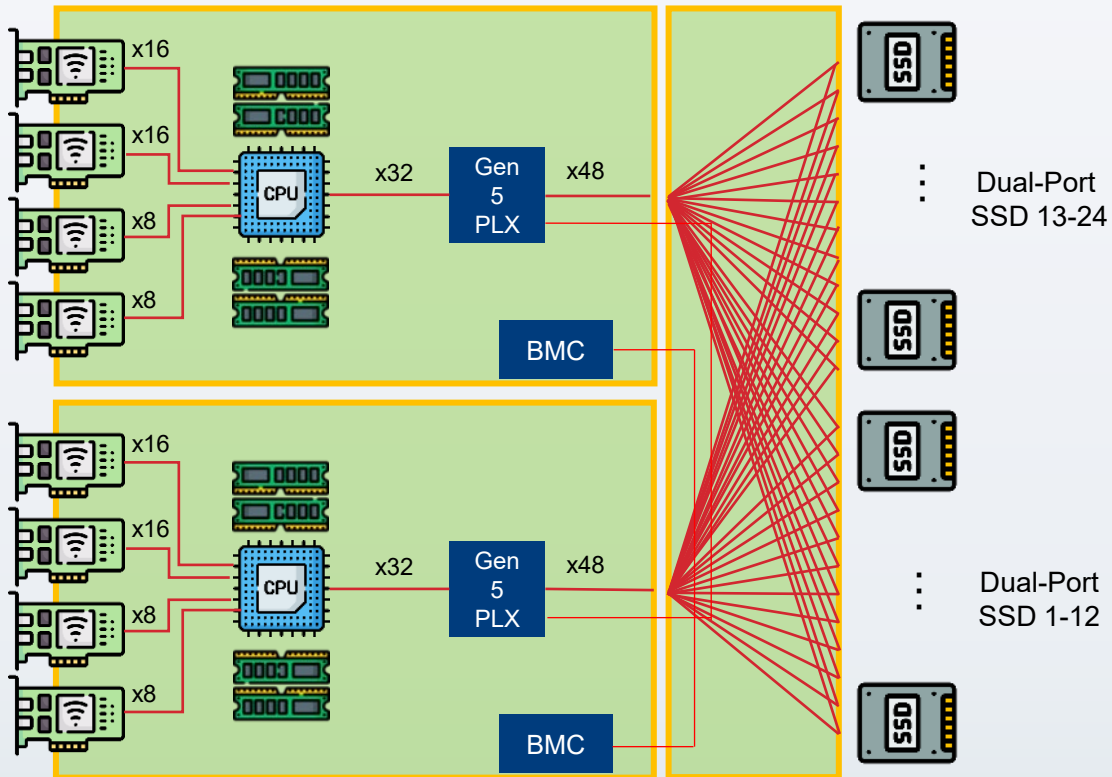

Key Features

- PCIe Gen5 architecture supports single processor
- 24x U.2 dual-port NVMe for high availability failover architecture
- Support node to node NTB (Non-Transparent Bridge) and gigabyte private link
- No single point-of-failure (SPOF)

Target Solutions

- Scale-up storage control node
- Mission critical database
- HPC large scale parallel file system
- AI high-performance storage

2U24 Dual-Port U.2 HA Storage Highlight

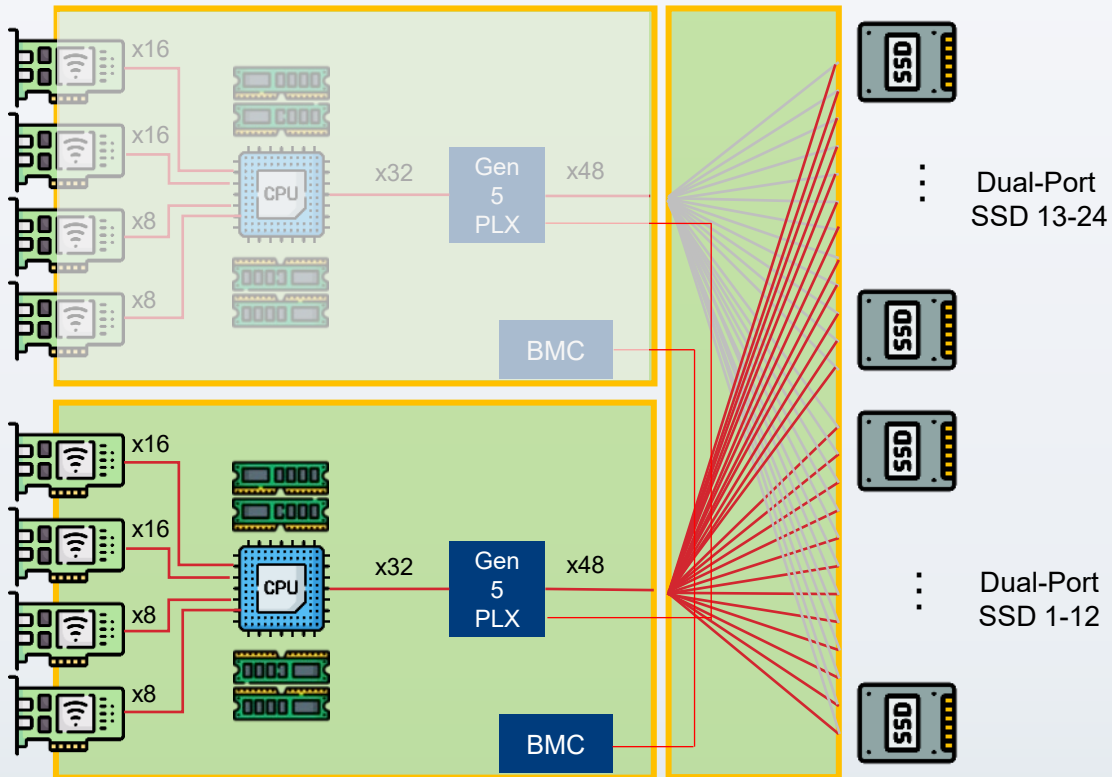

Key Features

- PCIe Gen5 architecture supports single processor
- 24x U.2 dual-port NVMe for high availability failover architecture
- Support node to node NTB (Non-Transparent Bridge) and gigabyte private link
- No single point-of-failure (SPOF)

Target Solutions

- Scale-up storage control node
- Mission critical database
- HPC large scale parallel file system
- AI high-performance storage

2U24 Dual-Port U.2 HA Storage Highlight

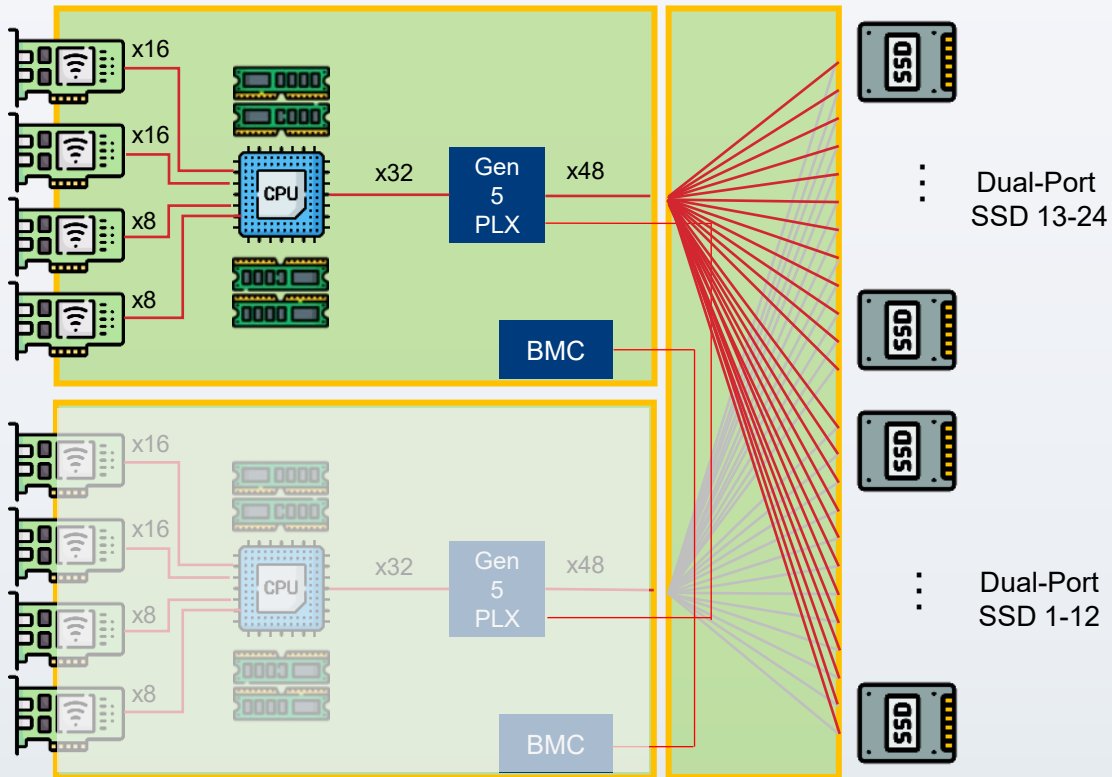

Key Features

- PCIe Gen5 architecture supports single processor
- 24x U.2 dual-port NVMe for high availability failover architecture
- Support node to node NTB (Non-Transparent Bridge) and gigabyte private link
- No single point-of-failure (SPOF)

Target Solutions

- Scale-up storage control node
- Mission critical database
- HPC large scale parallel file system
- AI high-performance storage



2U Simply Double Hybrid Storage

DDR5 Slots
Up to 12 DIMMs

Single Processor
Up to 300W TDP

3.5" SAS/SATA
Up to 24 slots

Redundant Power Supply
1600W (Titanium level)

PCIe 5.0 Slots
Up to 4x16 slots + 2 x8 slots
+ 2 x16 AIOMs

PCIe 5.0 NVMe
Up to 4 U.2 NVMe slots



Simply Double Enterprise Storage Specifications



2U Simply Double 24-Bay



2U Simply Double 24-Bay

Model Number	SSG-521E-E1CR24H/L	ASG-2015S-E1CR24H/L
CPU	Single 4 th Gen Intel® Xeon® Scalable Processors up to 300W TDP	Single AMD EPYC™ 9004 Series Processor up to 290W TDP
Memory	16 DIMM slots; Up to 4TB DDR5-4800	12 DIMM slots; Up to 3TB DDR5-4800
Expansion	4 PCIe 5.0 x8 FHHL slots 2 PCIe 5.0 x16 FHHL slots 2 PCIe 5.0 x16 AIOM slots	1 PCIe 5.0 x8 FHHL slot 5 PCIe 5.0 x16 FHHL slots 2 PCIe 5.0 x16 AIOM slots
Storage	24 front hot-swap 3.5" SAS/SATA 2 rear hot-swap 2.5" SATA	24 front hot-swap 3.5" SAS/SATA 2 rear hot-swap 2.5" SATA
Storage Controller	Broadcom® 3808 (E1CR24L) Broadcom® 3908 (E1CR24H)	Broadcom® 3808 (E1CR24L) Broadcom® 3908 (E1CR24H)
Networking	via AIOM	via AIOM
Power Supplies	Redundant 1600W Titanium level	Redundant 1600W Titanium level
Workloads	AI Big Data and Data Lake Scale Out Storage , Content Delivery Network Storage, Scale Out Object Storage, Storage Building Blocks	

2U24 Simply Double Hybrid Storage Highlight



Key Features

- PCIe Gen5 architecture supports single processor
- Up to 24x 3.5” HDD (576TB) for data storage and 4x Gen5 NVMe for caching
- Consolidate storage workloads and lower data center TCO

Sequential Read MB/s (256KB)

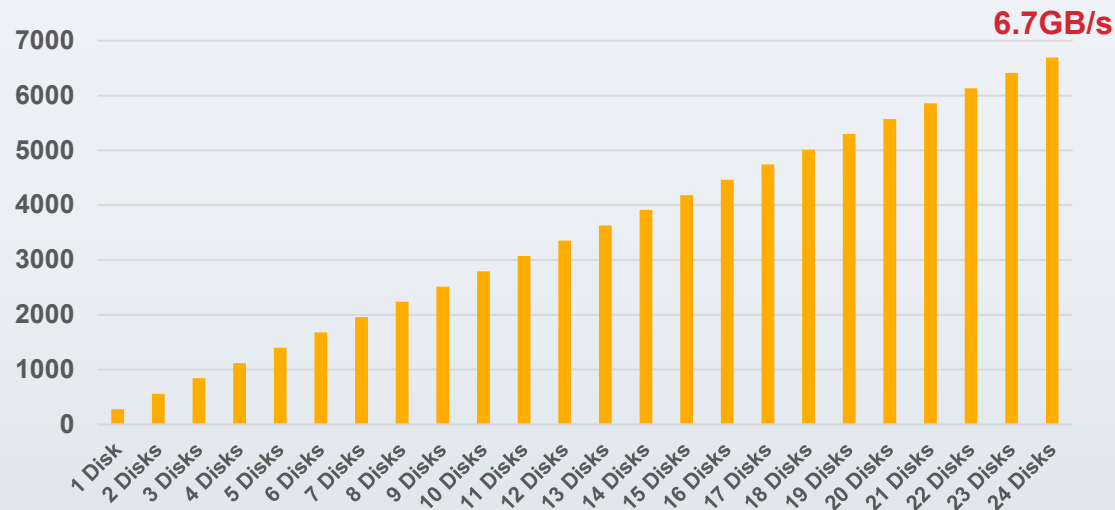

Target Solutions

- Big Data and Data Lake Hadoop storage
- SDS Cloud object storage
- CDN and video streaming



4U Cloud Scale Top Loading Storage

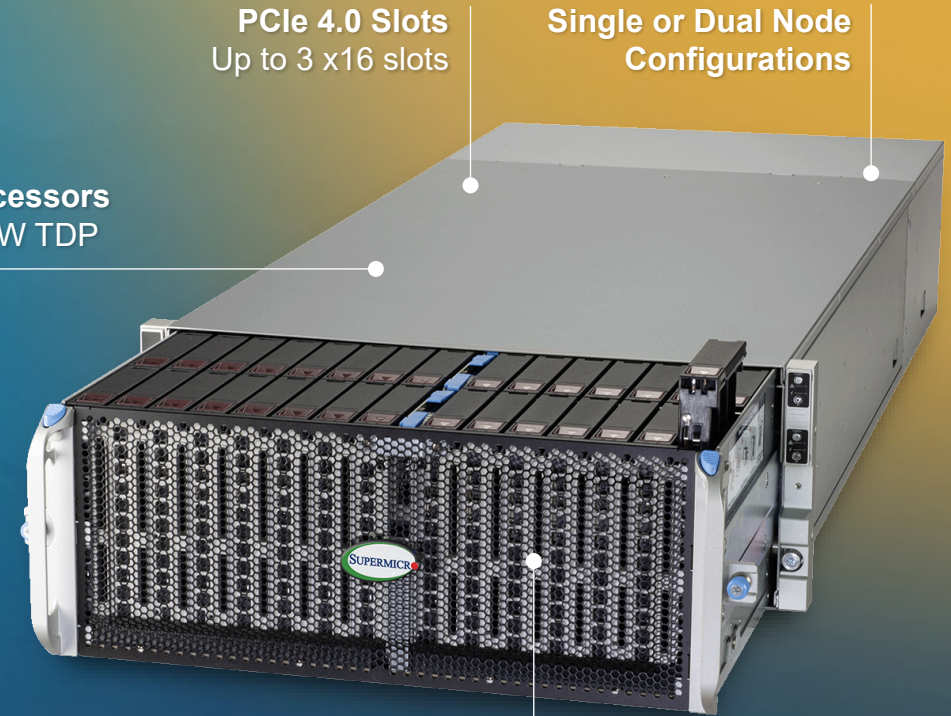

PCIe 4.0 Slots
Up to 3 x16 slots

Single or Dual Node Configurations

Dual Processors
Up to 270W TDP



Redundant Power Supply
2000/2600W (Titanium level)

PCIe 4.0 NVMe
Up to 4 U.2 NVMe slots

3.5" SATA/SAS Bays
60, 90 bay options

PCIe 4.0 Slots
Up to 3 x16 slots

2U24 Simply Double Hybrid Storage Highlight

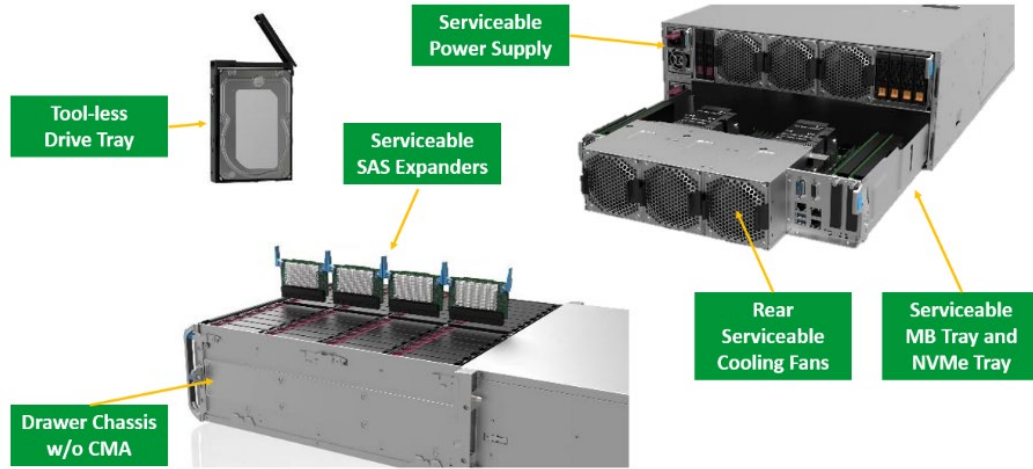

Key Features

- Single, Twin, SBB (HA) and JBOD configurations
- Up to 2.16 PB capacity in 90 bay or 1.44 PB capacity in 60 bay system. (w/ 24TB HDD)
- Enterprise-grade serviceability
- Best-in-Class performance

Target Solutions

- Cloud scale object storage
 - Back-Up target storage
 - Video streaming
 - Telco backend storage
 - Big-data and data-lake storage
- Big data Hadoop and HDFS files system
- Backup and active archive storage

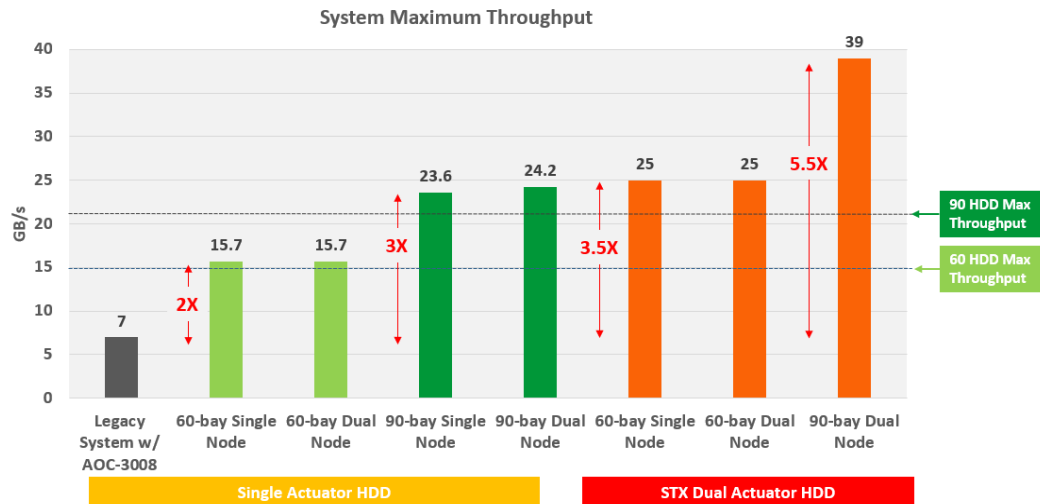

Single-Node Top Loading Storage Specifications

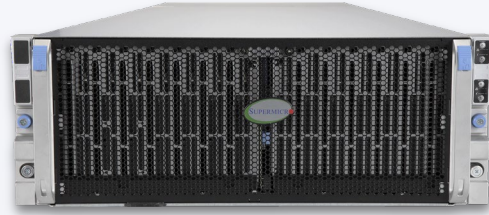

4U Single-Node 60-Bay

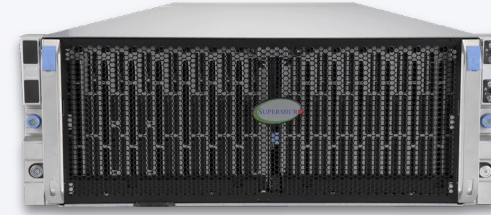

4U Single-Node 90-Bay

Model Number	SSG-640SP-E1CR60	SSG-640SP-E1CR90
CPU (per node)	Dual 3 rd Gen Intel® Xeon® Scalable Processors up to 205W TDP	Dual 3 rd Gen Intel® Xeon® Scalable Processors up to 205W TDP
Memory (per node)	16 DIMM slots; Up to 4TB DDR5-3200	16 DMM slots; Up to 4TB DDR4-3200
Expansion (per node)	3 PCIe 4.0 x16 LP slots	3 PCIe 4.0 x16 LP slots
Storage (per node)	60 hot-swap 3.5" SAS/SATA 2 rear hot-swap 2.5" SATA	90 hot-swap 3.5" SAS/SATA 2 rear hot-swap 2.5" SATA 4 optional 2.5" NVMe
Storage Controller	Broadcom® 3916 or 3616 (DE1CR60) Broadcom® 3616 (DE2CR60)	Broadcom® 3916 or 3616 (DE1CR90) Broadcom® 3616 (DE2CR90)
Networking (per node)	Dual 10GbE BaseT with Intel® X550	Dual 10GbE BaseT with Intel® X550
Power Supplies	Redundant 2000W Titanium level	Redundant 2600W Titanium level
Workloads	Big Data & Analytics, Data Lake, Telco & Cloud Service Providers, Contents Repositories, HPC and AI/ML Workloads, Financial Service & Healthcare Image Archives, Government Data Protection	

Dual-Node Top Loading Storage Specifications

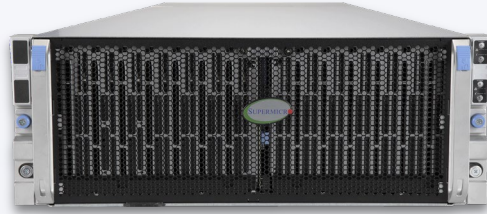

4U Dual-Node 60-Bay



4U Dual-Node 90-Bay

Model Number	SSG-640SP-DE1CR60 SSG-640SP-DE2CR60	SSG-640SP-DE1CR90 SSG-640SP-DE2CR90
CPU (per node)	Dual 3 rd Gen Intel® Xeon® Scalable Processors up to 205W TDP	Dual 3 rd Gen Intel® Xeon® Scalable Processors up to 205W TDP
Memory (per node)	16 DIMM slots; Up to 4TB DDR5-3200	16 DIMM slots; Up to 4TB DDR4-3200
Expansion (per node)	3 PCIe 4.0 x16 LP slots	3 PCIe 4.0 x16 LP slots
Storage (per node)	60 hot-swap 3.5" SAS/SATA 2 rear hot-swap 2.5" SATA	90 hot-swap 3.5" SAS/SATA 2 rear hot-swap 2.5" SATA 4 optional 2.5" NVMe
Storage Controller	Broadcom® 3916 or 3616 (DE1CR60) Broadcom® 3616 (DE2CR60)	Broadcom® 3916 or 3616 (DE1CR90) Broadcom® 3616 (DE2CR90)
Networking (per node)	Dual 10GbE BaseT with Intel® X550	Dual 10GbE BaseT with Intel® X550
Power Supplies	Redundant 2600W Titanium level	Redundant 2600W Titanium level
Workloads	Big Data & Analytics, Data Lake, Telco & Cloud Service Providers, Contents Repositories, HPC and AI/ML Workloads, Financial Service & Healthcare Image Archives, Government Data Protection	



2U/3U and 4U Enterprise Storage

DDR5 Slots
Up to 16 DIMMs

Dual Processors
Up to 270W TDP

3.5" SAS/SATA Bays
Up to 24 Front/12 Rear

Redundant Power Supply
1200W (Titanium level)

PCIe 5.0 Slots
For Controller Cards
and Expansion

Optional NVMe
Drives



Enterprise Optimized Storage Highlights



Key Features

- PCIe Gen5 architecture supports single processor
- Up to 36x 3.5" HDD and 6x Gen5 NVMe for caching optional
- Standard chassis design and fit-in the conventional DC rack (less than 28" deep)
- New PCIe Gen4 SAS3 12G HBA and RAID controller

Target Solutions

- Storage building blocks for Software-Defined Storage
- Enterprise scale-up solution with external JBOD extension



2U/3U Enterprise Storage Specifications



2U Front 16-Bay



3U Front 16-Bay

Model Number	SSG-621E-ACR16H/L	SSG-631E-E1CR16H/L
CPU	Dual 4 th Gen Intel® Xeon® Scalable Processors up to 270W TDP	Dual 4 th Gen Intel® Xeon® Scalable Processors up to 270W TDP
Memory	16 DIMM slots; Up to 4TB DDR5-4800	16 DIMM slots; Up to 4TB DDR5-4800
Expansion	2 PCIe 5.0 x8 LP slots 4 PCIe 5.0 x16 LP slots	2 PCIe 5.0 x8 LP slots 4 PCIe 5.0 x16 LP slots
Storage	12 front hot-swap 3.5" SAS/SATA (6 optional NVMe) 4 internal hot-swap 3.5" SATA 2 rear hot-swap 2.5" SATA	16 front hot-swap 3.5" SAS/SATA 2 rear hot-swap 2.5" SATA
Storage Controller	Broadcom® 3808 (ACR16L) Broadcom® 3908 (ACR16H)	Broadcom® 3808 (E1CR16L) Broadcom® 3908 (E1CR16H)
Networking	Dual 10GbE BaseT with Broadcom BCM57416	Dual 10GbE BaseT with Broadcom BCM57416
Power Supplies	Redundant 1600W Titanium level	Redundant 1200W Titanium level
Workloads	Enterprise Server, iSCSI SAN, HPC, Data Center, Database Processing & Storage, Corporate Database, Appliance Optimized Storage Building Blocks	

2U/3U Enterprise Storage Specifications



2U Front 16-Bay



3U Front 16-Bay

Model Number	SSG-641E-E1CR24H/L	SSG-641E-E1CR36H/L
CPU	Dual 4 th Gen Intel® Xeon® Scalable Processors up to 270W TDP	Dual 4 th Gen Intel® Xeon® Scalable Processors up to 270W TDP
Memory	16 DIMM slots; Up to 4TB DDR5-4800	16 DIMM slots; Up to 4TB DDR5-4800
Expansion	2 PCIe 5.0 x8 LP slots 4 PCIe 5.0 x16 LP slots	2 PCIe 5.0 x8 LP slots 4 PCIe 5.0 x16 LP slots
Storage	24 front hot-swap 3.5" SAS/SATA (6 optional NVMe) 2 rear hot-swap 2.5" SATA	24 front hot-swap 3.5" SAS/SATA (6 optional NVMe) 12 rear hot-swap 3.5" SAS/SATA 2 rear hot-swap 2.5" SATA
Storage Controller	Broadcom® 3808 (E1CR24L) Broadcom® 3908 (E1CR24H)	Broadcom® 3808 (E1CR36L) Broadcom® 3908 (E1CR36H)
Networking	Dual 10GbE BaseT with Broadcom BCM57416	Dual 10GbE BaseT with Broadcom BCM57416
Power Supplies	Redundant 1200W Titanium level	Redundant 1600W Titanium level
Workloads	Enterprise Server, iSCSI SAN, HPC, Data Center, Database Processing & Storage, Corporate Database, Appliance Optimized Storage Building Blocks	



Multi-Node Servers for Clustered Storage

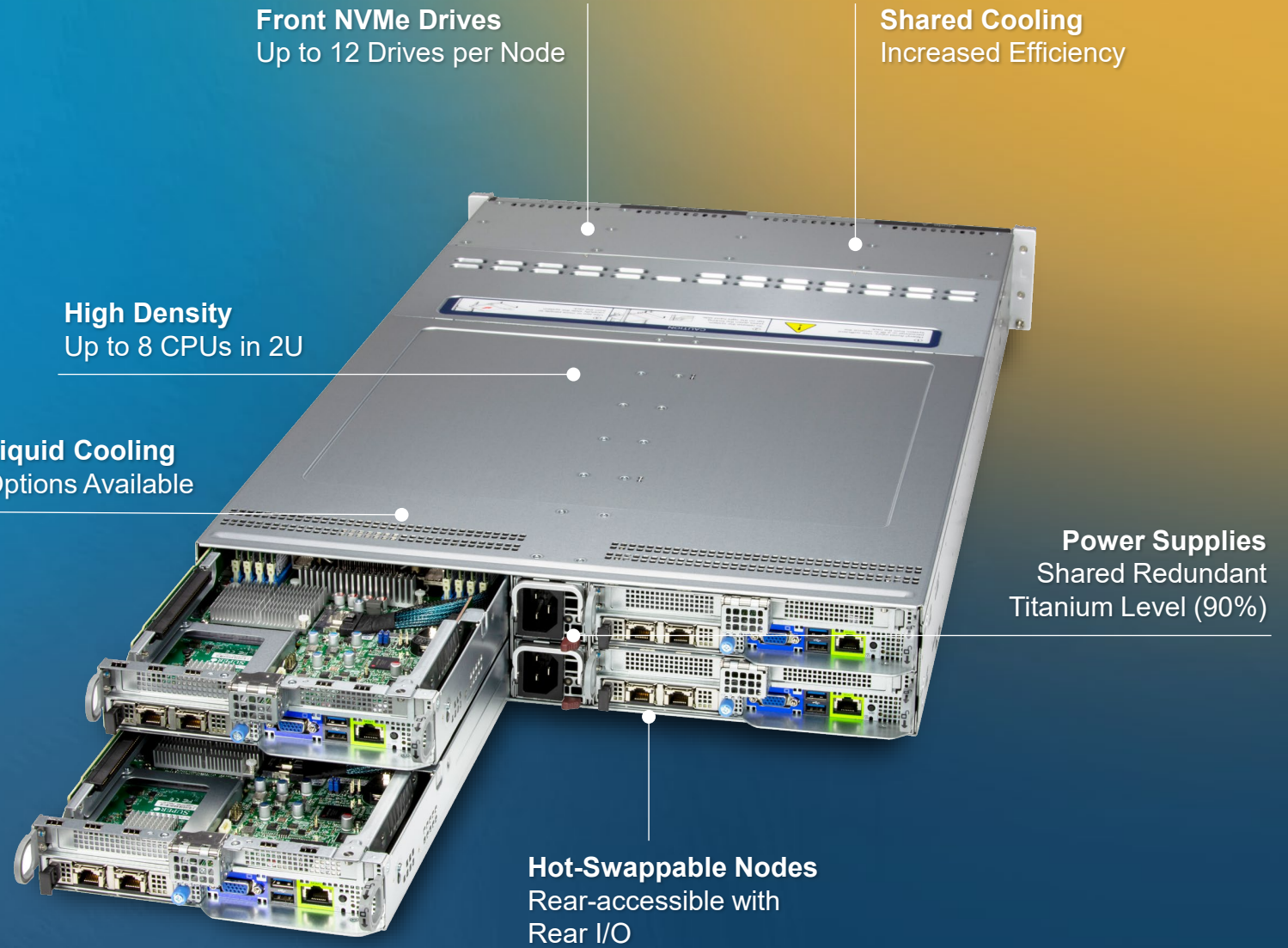

Front NVMe Drives
Up to 12 Drives per Node

Shared Cooling
Increased Efficiency

High Density
Up to 8 CPUs in 2U

Liquid Cooling
Options Available

Power Supplies
Shared Redundant
Titanium Level (90%)

Hot-Swappable Nodes
Rear-accessible with
Rear I/O

Multi-Node Family of Storage Servers

Compute-dense platform optimized for Cloud



BigTwin



GrandTwin

- High-efficiency for storage-intensive distributed applications and content delivery
- Rear-loading hot-swappable nodes with rear I/O and front-loading hot-swappable storage
- Compute/memory density optimized 2U 4-Node or thermal capacity optimized 2U 2-Node configuration
- Resource-saving architecture with shared power and cooling for optimal efficiency and lower TCO

Key Applications

- Clustered File and Object Storage
- High-Performance File Systems
- Hosting & Content Delivery
- Hyperconverged Infrastructure
- Diskless HPC Clusters

Performance Highlights

Multi-Node Storage Systems

Up to
12 drives

Per node

Front NVMe drives

Up to
8 CPUs

Per enclosure

2 CPUs (LGA 4677) per node

Up to
4TB

DDR5-5600 memory

Up to 16 DIMMs per node



Multi-Node Specifications



BigTwin (4-node)



GrandTwin

Model Number		
CPU (per node)	Dual-socket 5 th Gen Intel® Xeon® Scalable Processors	Single-socket 5 th Gen Intel® Xeon® Scalable Processors
Memory (per node)	16 DIMM slots; Up to 4TB DDR5-5600	16 DMM slots; Up to 4TB DDR4-5600
Expansion (per node)	2 PCIe 4.0 x16 LP slots	1 PCIe 5.0 x16 slot
Storage (per node)	Up to 12 front NVMe	4x 2.5" hot-swap NVMe/SATA drive bays (4x 2.5" NVMe dedicated) 2 M.2 NVMe OR 2 M.2 SATA3
Networking (per node)	AIOM Support	Via IO module
Power Supplies	Redundant 3000W Titanium level	Redundant 2200W Titanium level
Workloads	Big Data & Analytics, Data Lake, Telco& Cloud Service Providers, Contents Repositories, HPC and AI/ML Workloads, Financial Service & Healthcare Image Archives, Government Data Protection	



JBOD Expansion Units



Supermicro Storage Solution Partners

Scale Out/Up File



Object



Block & HCI





Thank you

supermicro.com