

IoT SuperServer SYS-212B-FLN2T

X14 2U compact front I/O edge AI system with up to 7 PCIe 5.0 slots and redundant AC/DC PSU



Key Applications

AI Inference and Machine Learning, Cloud Computing, Network Function Virtualization (NFV), 5G Networking,

Key Features

- Intel® Xeon® 6700/6500 series processors with P-cores or 6700 series processors with E-cores;
- 2000W 100-240Vac Platinum Single Power Supply (can be upgraded to redundant power supply);
- Up to 8 DIMMs supporting up to 1TB DDR5-6400;
- 2x 10GbE LAN (X550), 2x USB3.2;
- 4x 2.5" NVMe (Optional), 2 M.2 M-Key NVMe, 22110;
- Support for up to 4 single-width GPU cards, 1 double-width GPU (optional);
- 1 PCIe x16 (FHFL, optional), 3 PCIe 5.0 x16(HHFL), 3 PCIe 5.0 x8(HHFL);
- Onboard TPM9672: TCG2.0, FIPs 140-2 Level 2, Intel TXT and Microsoft Windows certification;



Form Factor	2U Rackmount Enclosure: 437 x 89 x 450mm (17.2" x 3.5" x 17.72") Package: 720 x 266 x 555mm (28.35" x 10.47" x 21.85")
Processor	Single Socket E2 (LGA-4710) Intel® Xeon® 6700/6500 series processors with P-cores or 6700 series processors with E-cores P-cores: Up to 86C/172T; Up to 336MB Cache E-cores: Up to 144C/144T; Up to 108MB Cache
GPU	Max GPU Count: Up to 1 double-width or 4 single-width GPUs CPU-GPU Interconnect: PCIe 5.0 x16 CPU-to-GPU Interconnect GPU-GPU Interconnect: PCIe
System Memory	Slot Count: 8 DIMM slots Max Memory (1DPC): Up to 2TB 6400MT/s ECC DDR5 RDIMM
Drive Bays Configuration	Default: Total 4 bays <ul style="list-style-type: none"> • 4 rear hot-swap 2.5" NVMe* drive bays (*NVMe support may require additional storage controller and/or cables) M.2: 2 M.2 PCIe 5.0 x2 NVMe slots (M-key 22110(default))
Expansion Slots	PCI-Express (PCIe) Configuration: Default* <ul style="list-style-type: none"> • 3 PCIe 5.0 x16 (in x16) HHFL slots • 3 PCIe 5.0 x8 (in x8) HHFL slots Option A* <ul style="list-style-type: none"> • 3 PCIe 5.0 x16 (in x16) HHFL slots • 3 PCIe 5.0 x8 (in x8) HHFL slots • 1 PCIe 5.0 x16 (in x16) FHFL double-width slot (*Requires additional parts, please see the optional parts list for details. For more details on PCIe slot configuration options, please refer to the system callout images above.) M.2: 2 M.2 NVMe slots (M-key 22110)
On-Board Devices	NVMe: NVMe; RAID 0/1/5/10 support(Intel® VROC RAID key required) Network Connectivity: 2 RJ45 10GBASE-T with Intel® X550
Input / Output	LAN: 1 RJ45 1 GbE Dedicated BMC LAN port 2 RJ45 10 GbE LAN ports USB: 2 USB 3.2 Gen1 Type-A ports(front) Video: 1 VGA port

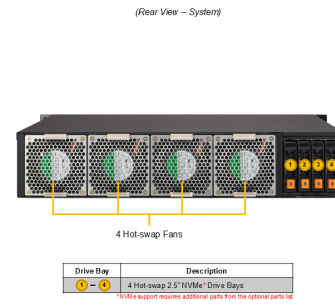
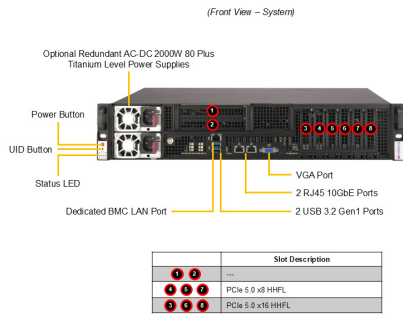

System Cooling	Fans: Up to 4x 4-PIN PWM 8cm Fan(s) Air Shroud: 1 Air Shroud
Power Supply	1x 2000W Redundant Titanium Level (96%) power supply
System BIOS	BIOS Type: AMI 64MB UEFI BIOS Features: ACPI 6.5 SMBIOS 3.7 or later UEFI 2.9
Management	SuperCloud Composer®; Supermicro Server Manager (SSM); Super Diagnostics Offline (SDO); Supermicro Thin-Agent Service (TAS); SuperServer Automation Assistant (SAA) New!
PC Health Monitoring	CPU: Monitors for CPU Cores, Chipset Voltages, Memory FAN: Fans with tachometer monitoring Pulse Width Modulated (PWM) fan connectors Status monitor for speed control Temperature: CPU thermal trip support, PEPI Monitoring for CPU and chassis environment
Dimensions and Weight	Weight: Gross Weight: 23 lbs (10.43 kg) Net Weight: 17 lbs (7.7 kg) Available Color: Black
Operating Environment	Operating Temperature: 0°C to 40°C (32°F to 104°F) Non-operating Temperature: -40°C to 70°C (-40°F to 158°F) Operating Relative Humidity: 8% to 90% (non-condensing) Non-operating Relative Humidity: 5% to 95% (non-condensing)
Motherboard	Super X14SBI-TF
Chassis	CSE-223M-R000LPNDP